

ABB Drives

Quick installation guide

WBCA-xx bottom connection adapter

Purpose

The WBCA bottom connection adapter enables supply connection from the bottom side of the WFU regen filter module mounted onto it. Check the table on the right for the right adapter type.

Adapter type	Filter types
WBCA-01	WFU-01, WFU-02
WBCA-11	WFU-11
WBCA-21	WFU-21, WFU-22

Installation steps

1	Mount the WBCA adapter on the wall (4 screws).
2	Mount the WFU filter on the WBCA adapter (4 screws).
3	Connect the cable of the WBCA adapter to the L1/L2/L3 of the WFU filter. (Cable included)
4	Connect the mains input to the L1/L2/L3/PE of the WBCA adapter.

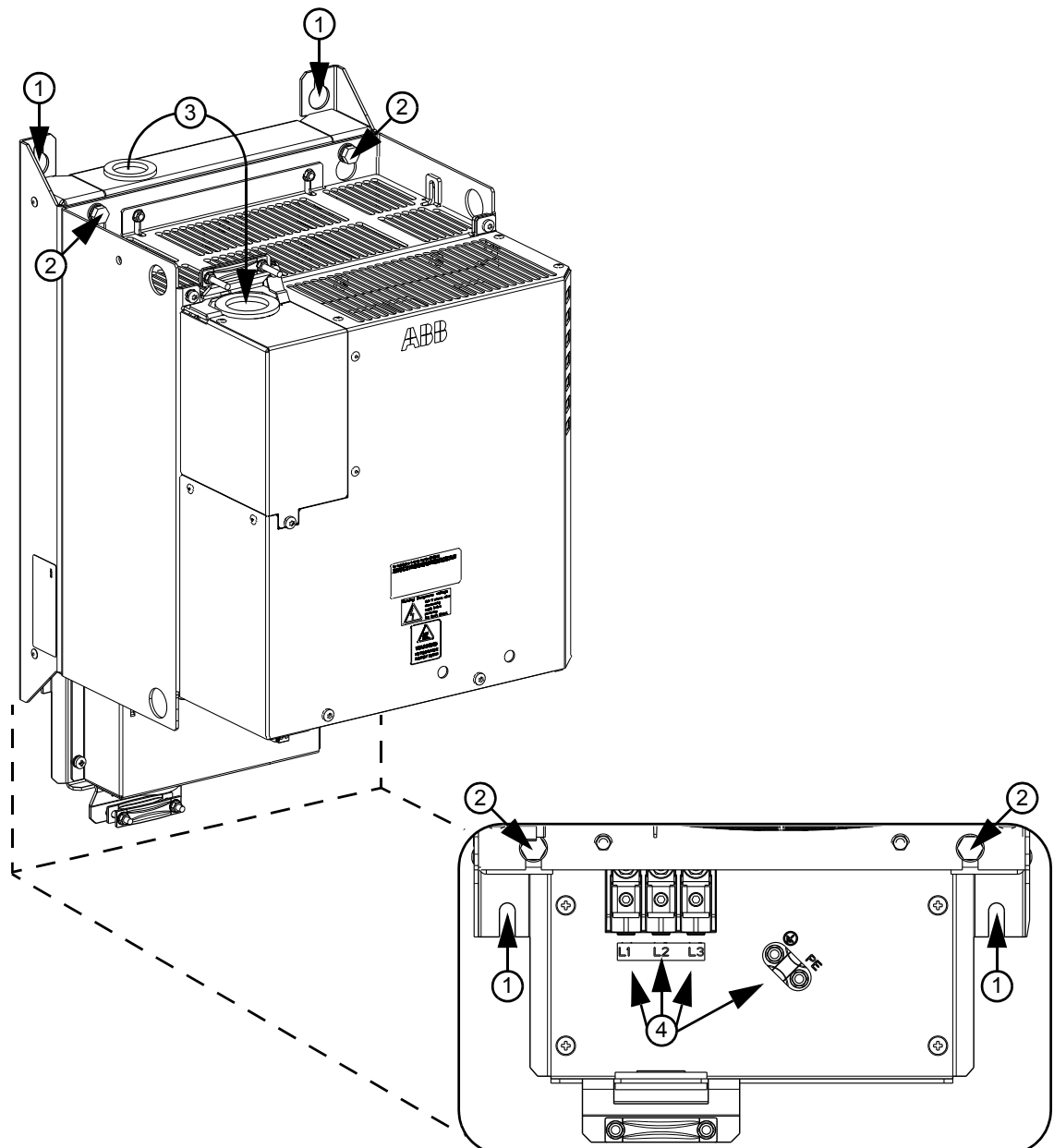

Dimensions and weight

WBCA-01

Weight	2.5 kg / 5.5 lbs
Weight with WFU-01	13.5 kg / 30 lbs
Weight with WFU-02	16.5 kg / 36 lbs
Depth with WFU-0x	253 mm / 10.0 in

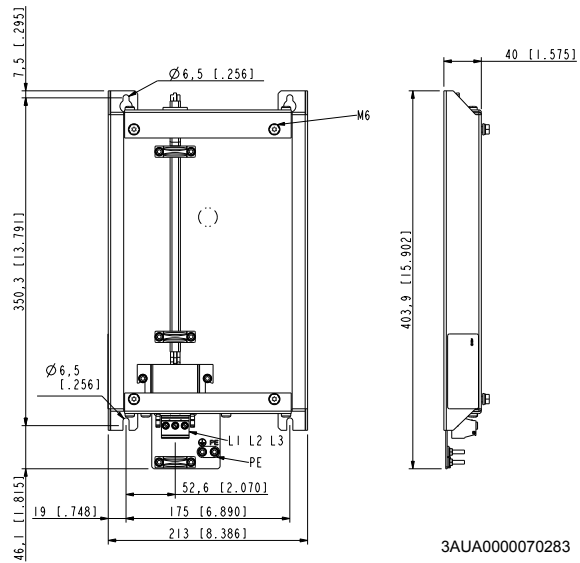

3AUA0000070283

WBCA-11

Weight	6.5 kg / 14.5 lbs
Weight with WFU-11	40.5 kg / 89.5 lbs
Depth with WFU-11	310 mm / 12.2 in

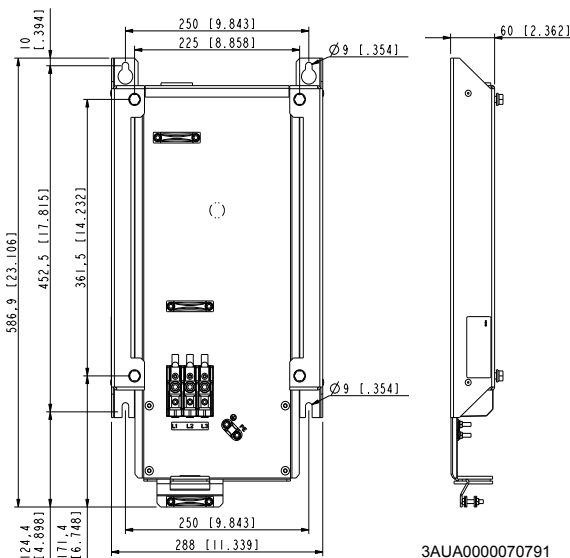

3AUA0000070791

WBCA-21

Weight	8 kg / 17.5 lbs
Weight with WFU-21	53 kg / 116.5 lbs
Weight with WFU-22	59.5 kg / 131 lbs
Depth with WFU-2x	354 mm / 13.9 in

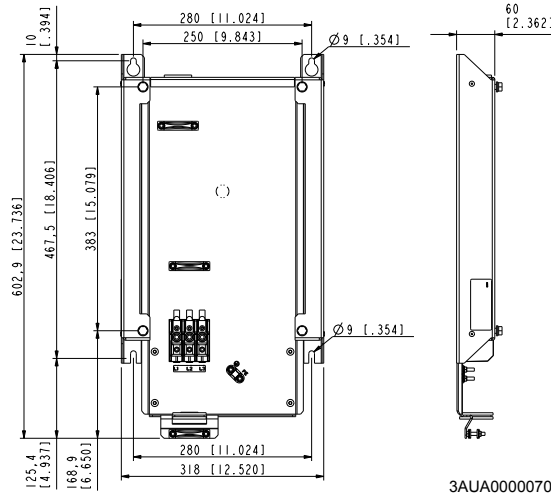

3AUA0000070789

3AUA0000072562 Rev A EN 2010-02-10



ABB Oy

Drives
P.O. Box 184
FI-00381 HELSINKI
FINLAND
Telephone +358 10 22 11
Fax +358 10 22 22681
www.abb.com/drives

ABB Inc.

Automation Technologies
Drives & Motors
16250 West Glendale Drive
New Berlin, WI 53151
USA
Telephone 262 785-3200
1-800-HELP-365
Fax 262 780-5135
www.abb.com/drives

ABB Beijing Drive Systems Co. Ltd.

No. 1, Block D, A-10 Jiuxianqiao Beilu
Chaoyang District
Beijing, P.R. China, 100015
Telephone +86 10 5821 7788
Fax +86 10 5821 7618
www.abb.com/drives