

# ABB Drives

## User's Manual Ethernet POWERLINK Adapter Module REPL-02

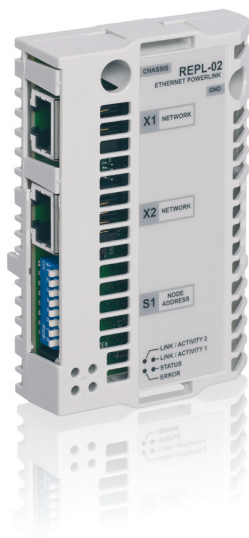



Ethernet POWERLINK Adapter Module  
REPL-02

**User's Manual**

3AUA0000090411 REV A EN

EFFECTIVE: 2010-12-22



# Safety instructions

---

## What this chapter contains

This chapter states the general safety instructions that must be followed when installing and operating the REPL-02 Ethernet POWERLINK Adapter module.

The material in this chapter must be studied before attempting any work on the unit.

In addition to the safety instructions given below, read the complete safety instructions of the specific drive you are working on.

## General safety instructions



**WARNING!** All electrical installation and maintenance work on the drive should be carried out by qualified electricians.

The drive and adjoining equipment must be properly earthed.

Do not attempt any work on a powered drive. After switching off the mains, always allow the intermediate circuit capacitors 5 minutes to discharge before working on the frequency converter, the motor or the motor cable. It is good practice to check (with a voltage indicating instrument) that the drive is in fact discharged before beginning work.

The motor cable terminals of the drive are at a dangerously high voltage when mains power is applied, regardless of motor operation.

There can be dangerous voltages inside the drive from external control circuits even when the drive mains power is shut off. Exercise appropriate care when working on the unit. Neglecting these instructions can cause physical injury or death.



# Table of contents

---

<b>Safety instructions</b> .....	<b>5</b>
What this chapter contains .....	5
General safety instructions .....	5
 <b>Table of contents</b> .....	 <b>7</b>
 <b>Introduction</b> .....	 <b>11</b>
What this chapter contains .....	11
Intended audience .....	11
Before you start .....	11
What this manual contains .....	11
Terms used in this manual .....	13
Communication module .....	13
Data sets and data words .....	13
REPL-02 Ethernet Powerlink Adapter module .....	13
Parameter .....	13
Further information .....	13
Product and service inquiries .....	14
Product training .....	14
Providing feedback on ABB Drives manuals .....	14
 <b>Overview</b> .....	 <b>15</b>
What this chapter contains .....	15
Ethernet POWERLINK .....	15
REPL-02 Ethernet POWERLINK Adapter module .....	16
Compatibility .....	17
Delivery check .....	17
Warranty and liability information .....	18

<b>Quick start-up guide</b> .....	<b>19</b>
Overview .....	19
Installation .....	19
Drive configuration .....	20
PLC configuration .....	21
Adding the .xdd file .....	22
Associating the REPL-02 with the PLC .....	22
Mapping objects required for controlling the drive .....	23
Building a project and transferring it to the PLC .....	24
Forcing values .....	24
<b>Mechanical installation</b> .....	<b>25</b>
What this chapter contains .....	25
Mounting .....	25
<b>Electrical installation</b> .....	<b>27</b>
What this chapter contains .....	27
General cabling instructions .....	27
Ethernet POWERLINK connections .....	27
Node address selection .....	28
Ethernet POWERLINK network topology .....	29
<b>Drive configuration</b> .....	<b>31</b>
What this chapter contains .....	31
REPL-02 configuration .....	31
The REPL-02 configuration parameters .....	32
1 MODULE TYPE .....	32
2 TRANSPARENT/PROFILE MODE .....	32
3 NODE ID .....	32
<b>Master configuration</b> .....	<b>33</b>
What this chapter contains .....	33
Configuring the system .....	33
XML Device Description Files .....	33

<b>Communication profiles</b> .....	<b>35</b>
What this chapter contains .....	35
Communication profiles .....	35
The CANopen device profile DSP 402 .....	35
Device Control state machine .....	35
Supported mode of operation .....	36
Control Word and Status Word of the DSP 402 profile .....	36
Reference of the DSP 402 profile .....	41
Actual value of the DSP 402 profile .....	41
ABB Drives communication profile .....	41
The Control Word and the Status Word .....	41
Control Word and Status Word of the ABB Drives profile .....	42
References .....	47
Scaling .....	47
Actual values .....	48
Scaling .....	48
 <b>Communication</b> .....	 <b>49</b>
What this chapter contains .....	49
Ethernet POWERLINK communication cycle .....	49
Ethernet POWERLINK state machine .....	50
NMT_GS_INITIALISATION .....	50
NMT_GS_COMMUNICATING .....	51
NMT_CS_NOT_ACTIVE .....	51
The NMT_CS_PREOPERATIONAL states .....	51
NMT_CS_READY_TO_OPERATE .....	51
NMT_CS_OPERATIONAL .....	51
NMT_CS_STOPPED .....	51
DS 301 and DS 402 specification .....	53
Process Data Objects (PDO) .....	53
Service Data Objects (SDOs) .....	54
SDO Protocol .....	54
Network Management Services .....	55
NMT State Command Services .....	55
NMT Response Services .....	55
Error entry specification .....	56

10	
<b>Diagnostics</b>	<b>57</b>
LED indications	57
<b>CANopen object dictionary</b>	<b>59</b>
Overview	59
Communication profile objects	59
Communication profile objects	59
Manufacturer specific profile objects	66
Manufacturer specific profile objects	67
Drive data sets	68
Drive data sets	69
Drive actual signals and parameters	69
Drive signals and parameters	70
DSP 402 profile objects	71
DSP 402 profile objects	71
<b>Emergency messages, DS301 and DS402</b>	<b>75</b>
What this chapter contains	75
Error codes	75
Error codes	75
<b>Definitions and abbreviations</b>	<b>83</b>
<b>Technical data</b>	<b>85</b>
What this chapter contains	85
REPL-02	85
Ethernet POWERLINK link	86
<b>Appendix: IdentResponse Frame</b>	<b>87</b>

# Introduction

---

## What this chapter contains

This chapter describes the REPL-02 Ethernet POWERLINK Adapter Module User's Manual.

## Intended audience

The manual is intended for people responsible for commissioning and using an REPL-02 Ethernet POWERLINK Adapter module. The reader is expected to have a basic knowledge of electrical fundamentals, electrical wiring practices and how to operate the drive.

## Before you start

It is assumed that the drive is installed and ready to operate before starting the installation of the extension module.

In addition to conventional installation tools, have the drive manuals available during the installation as they contain important information not included in this manual. The drive manuals are referred to at various points of this manual.

## What this manual contains

This manual contains information on the wiring, configuration and the use of the REPL-02 Ethernet POWERLINK Adapter module.

It is assumed that the drive is installed and ready to operate before starting the installation of the adapter module. For more information on the installation and start-up procedures of the drive, see the appropriate drive manuals.

*Safety instructions* are featured in the first few pages of this manual.

*Overview* contains a short description of the Ethernet POWERLINK protocol and the REPL-02 Ethernet POWERLINK

Adapter module, a delivery checklist, and information on the manufacturer's warranty.

*Quick start-up guide* contains a short description of how to set up the REPL-02 Ethernet POWERLINK Adapter module.

*Mechanical installation* contains placing and mounting instructions for the module.

*Electrical installation* contains wiring instructions.

*Drive configuration* explains how to program the drive before the communication through the adapter module can be started.

*Master configuration* explains how to program the Ethernet POWERLINK master before the communication through the adapter module can be started.

*Communication profiles* describes the communication profiles used in the communication between the Ethernet POWERLINK network, the REPL-02 module, and the drive.

*Communication* contains a description of how data is transmitted through the REPL-02 module.

*Diagnostics* explains how to trace faults with the status LEDs on the REPL-02 module.

*CANopen object dictionary* describes the CANopen Object Dictionary used by the module.

*Emergency messages, DS301 and DS402* contains reference tables for decoding CANopen error messages.

*Definitions and abbreviations* explains definitions and abbreviations concerning the Ethernet POWERLINK protocol family.

*Technical data* contains information on physical dimensions, connectors of the module and the specification of the Ethernet POWERLINK link.

## Terms used in this manual

### *Communication module*

Communication module (often abbreviated COMM. MODULE or COMM.) is a parameter name / parameter selection name for a device (e.g. a fieldbus adapter) through which the drive is connected to an external serial communication network. The communication with the communication module is activated with a drive parameter (see the appropriate drive firmware manual).

### *Data sets and data words*

Each data set consists of three 16-bit words, i.e. data words. The Control Word (sometimes called the Command Word) and the Status Word, References and Actual Values (see chapter *Communication profiles* on [page 35](#)) are types of data words; the contents of some data words are user-definable.

### *REPL-02 Ethernet Powerlink Adapter module*

The REPL-02 Ethernet Powerlink Adapter module is one of the optional fieldbus adapter modules available for ABB drives. The REPL-02 is a device through which an ABB drive is connected to an Ethernet POWERLINK network.

### *Parameter*

A parameter is an operating instruction for the drive. Parameters can be read and programmed with the drive control panel, or through the REPL-02 module.

## Further information

Further information on the Ethernet POWERLINK protocol is available on the World Wide Web from [www.ethernet-powerlink.org](http://www.ethernet-powerlink.org)

## Product and service inquiries

Address any inquiries about the product to your local ABB representative, quoting the type code and serial number of the unit in question. A listing of ABB sales, support and service contacts can be found by navigating to [www.abb.com/drives](http://www.abb.com/drives) and selecting *Sales, Support and Service network*.

## Product training

For information on ABB product training, navigate to [www.abb.com/drives](http://www.abb.com/drives) and select *Training courses*.

## Providing feedback on ABB Drives manuals

Your comments on our manuals are welcome. Go to [www.abb.com/drives](http://www.abb.com/drives), then select *Document Library – Manuals feedback form (LV AC drives)*.

# Overview

---

## What this chapter contains

This chapter contains a short description of the Ethernet POWERLINK protocol and the REPL-02 Ethernet POWERLINK Adapter module, a delivery checklist and warranty information.

## Ethernet POWERLINK

Ethernet POWERLINK is a communication profile for Real Time Ethernet. It extends standard Ethernet IEEE802.3 with a mechanism to transfer data deterministically. The mechanism is called Slot Communication Network Management (SCNM). SCNM is managed by a networked device designated as the Managing Node (MN). All other nodes are Controlled Nodes (CN). The REPL-02 is capable of participating in an Ethernet POWERLINK network as a CN.

Unlike standard Ethernet, SCNM ensures that only one node is accessing the network at a time. The schedule is divided into an isochronous phase and an asynchronous phase. During the isochronous phase, time-critical data is transferred, while the asynchronous phase provides bandwidth for the transmission of data that is not time-critical. The MN grants access to the physical medium via dedicated poll request messages. As a result, only one CN has access to the network at a time, and thus no collisions occur.

Ethernet POWERLINK applies the same protocol technology as CANopen. It defines SDOs (Service Data Objects), PDOs (Process Data Objects) and the Object Dictionary structure to manage the parameters.

Further information is available from the Ethernet POWERLINK Standardization Group ([www.ethernet-powerlink.org](http://www.ethernet-powerlink.org)).

## REPL-02 Ethernet POWERLINK Adapter module

The REPL-02 Ethernet POWERLINK Adapter module is an optional device for ABB drives which enables the connection of the drive to an Ethernet POWERLINK network. Through the REPL-02 Ethernet POWERLINK Adapter module it is possible to

- give control commands to the drive (Start, Stop, Run enable, etc.)
- feed a motor speed or torque reference to the drive
- give a process actual value or a process reference to the PID controller of the drive
- read status information and actual values from the drive
- reset a drive fault.

The Ethernet POWERLINK commands and services supported by the REPL-02 Ethernet POWERLINK Adapter module are discussed in the chapter [Communication](#) on [page 49](#). Please refer to the user documentation of the drive as to which commands are supported by the drive.

The adapter module is mounted into an option slot on the motor control board if the drive. See the drive manuals for module placement options.

The module is classified as a full Ethernet POWERLINK slave.

Device Description files for ABB Drives are available through your local ABB representative and the ABB Library ([www.abb.com](http://www.abb.com)).

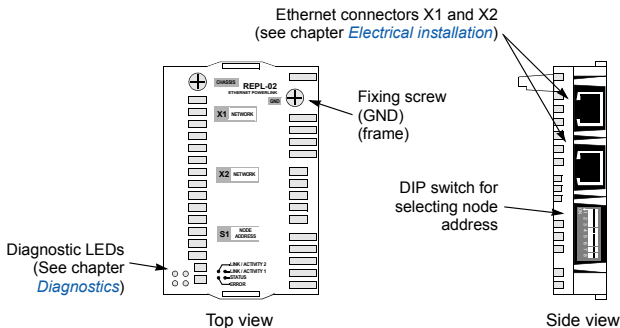

Figure 1. The REPL-02 Adapter module.

## Compatibility

The REPL-02 module is compatible with all master stations that support the Ethernet POWERLINK protocol.

## Delivery check

The option package for the REPL-02 Ethernet POWERLINK Adapter module contains:

- Ethernet POWERLINK Adapter module, type REPL-02
- two screws (M3x10)
- this manual.

## Warranty and liability information

The manufacturer warrants the equipment supplied against defects in design, materials and workmanship for a period of twelve (12) months after installation or twenty-four (24) months from date of manufacturing, whichever first occurs. The local ABB office or distributor may grant a warranty period different to the above and refer to local terms of liability as defined in the supply contract.

The manufacturer is not responsible for

- any costs resulting from a failure if the installation, commissioning, repair, alternation, or ambient conditions of the unit do not fulfil the requirements specified in the documentation delivered with the unit and other relevant documentation
- units subjected to misuse, negligence or accident
- units comprised of materials provided or designs stipulated by the purchaser.

In no event shall the manufacturer, its suppliers or subcontractors be liable for special, indirect, incidental or consequential damages, losses or penalties.

This is the sole and exclusive warranty given by the manufacturer with respect to the equipment and is in lieu of and excludes all other warranties, express or implied, arising by operation of law or otherwise, including, but not limited to, any implied warranties of merchantability or fitness for a particular purpose.

If you have any questions concerning your ABB drive, please contact the local distributor or ABB office. The technical data, information and specifications are valid at the time of printing. The manufacturer reserves the right to modifications without prior notice.

# Quick start-up guide

---

## Overview

This chapter presents the steps to take during the start-up of the REPL-02 Ethernet POWERLINK Adapter module to set up communication between a PLC and REPL-02, allowing the drive to be controlled from the fieldbus.

The parameter settings are given for ACS800 and ACS550 drives. The PLC used in the example is a B&R X20 CP1485, and B&R Automation Studio PC software is used to configure it. The information should, however, be easily adaptable for use with other PLCs as well.



---

**WARNING!** Follow the safety instructions given in this manual and the *Manuals* of the drive.

---

## Installation

This section describes how to physically connect and configure the equipment.

1. Set the node ID with the DIP switch S1 on the module. In this example, the node ID used is 3, which is selected by flipping the actuators 7 and 8 to ON position and the actuators 1...6 to OFF position.
2. Mount the REPL-02.
  - Insert the REPL-02 into its specified slot in the drive (SLOT2 for ACS550, SLOT1 for ACS800).
  - Fasten the two screws.
3. Connect the module (connector X1 – NETWORK) and the PLC (connector IF3 – EPL) to the hub with Ethernet cable. Avoid parallel runs with power (e.g. motor) cables. Use straight-through

CAT 5 cables and only the normal ports of the hub. Do not use an uplink port.

4. Connect the PLC to a serial port of the PC on which the B&R Automation Studio is installed.

## Drive configuration

This section describes how to set the drive parameters to allow the REPL-02 module to control the drive. The ABB Drives (transparent) communication profile will be used. For more information, see the appropriate drive manual.

---

**Note:** The detailed procedure of activating the drive for communication with the module is dependent on the drive type. Normally, a parameter must be adjusted to activate the communication. Refer to the *Firmware Manual* of the drive for information on the communication settings.

---

1. Power up the hub, the drive, and the PLC.
2. Enable the fieldbus module by setting parameter 98.02 COMM MODULE LINK to FIELDBUS.
3. **ACS800 only:** Set the drive to use the ABB Drives profile by setting parameter 98.07 COMM PROFILE to ABB DRIVES.
4. Set parameter 51.02 to 1 (Transparent mode).
5. Start a "Fieldbus adapter parameter refresh" by setting parameter 51.27 FBA PAR REFRESH to REFRESH.
6. Configure the drive to be controlled from the fieldbus. For an example configuration, see the tables below.

### *Parameters in ACS550*

Drive parameter	Example setting
10.01 EXT1 COMMANDS	COMM
11.02 EXT1/EXT2 SEL	EXT1
11.03 REF1 SELECT	COMM

### Parameters in ACS800

Drive parameter	Example setting
10.01 EXT1 STRT/STP/DIR	COMM.CW
11.02 EXT1/EXT2/SELECT	EXT1
11.03 EXT REF1 SELECT	COMM.REF

## PLC configuration

This section describes the steps to configure the PLC with B&R Automation Studio PC software, so that it can be used to control the drive using the REPL-02 module.

1. Create a new project in Automation Studio for your PLC, or open an existing project. See B&R documentation for more information.
2. In the Project Explorer window, open the **Physical View** tab.
3. Right-click the node representing the CPU (in this example, X20CP1485-1), and in the pop-up menu, select Open IF3 POWERLINK Configuration. The POWERLINK Configuration window is opened.
4. Make the following settings:
  - Activate POWERLINK communication: on
  - Asynchronous timeout [ $\mu$ s]: 400
5. Close the window, and save changes when prompted.

## Adding the .xdd file

---

**Note:** The .xdd file provides the PLC and Automation Studio information on the capabilities of the fieldbus device. You can obtain the file from <http://www.abb.com/>, or your local ABB representative.

---

1. In the Tools menu of the Automation Studio, select **Import Fieldbus Device...**
2. In the Open window, select the correct .xdd file for your drive and click **Open**.

## Associating the REPL-02 with the PLC

When the .xdd file has been imported, add the REPL-02 module to the list of POWERLINK devices associated with the PLC.

1. In the Project Explorer window, right-click the CPU node, and click **Open POWERLINK** in the pop-up menu.

The POWERLINK window opens, displaying the list of devices connected to the Powerlink interface (IF3) of the PLC.

2. To add the REPL-02 module, right-click the IF3 list entry and select **Insert...** in the pop-up menu.

The Select controller module window opens, allowing you to choose the device to add.

3. Select the entry for REPL-02 module and your drive, and click **Next >**.
4. Enter the node number and optionally, a name for the module. (Earlier in this example configuration, the Node number was set to 3 with the DIP switches on the module.)
5. Click **Next >**.

The REPL-02 module is now displayed in the POWERLINK window, as well as in the Project Explorer. You can close the POWERLINK window.

## Mapping objects required for controlling the drive

1. In the Project Explorer window, right-click the entry for the REPL-02 module, and select **Open I/O Configuration** in the pop-up menu.
2. In the I/O Configuration window, make the following settings:
  - General - Module supervised: **off**

---

**Note:** Setting Module supervised to **on** causes the PLC to drop into service mode if the communication with the module fails. This may be desirable in production environment. However, in testing the recommended setting is **off**.

---

- Channels - TransparentControlWord\_I2005 - Cyclic transmission: **Write**
- TransparentReferenceSpeed\_I2006 - Cyclic transmission: **Write**

---

**Note:** Use Transparent objects (I2004-I2008) when the module is in Transparent mode and Profile objects (I6040 onwards) when the module is in Profile mode.

---

- Channels - TransparentStatusWord\_I2007 - Cyclic transmission: **Read**
- Channels - TransparentActualFeedback\_I2008 - Cyclic transmission: **Read**

## Building a project and transferring it to the PLC

1. Select **Build Configuration** in the Project menu.

In the beginning of the build process, the changes are automatically saved to the project. When the build is finished, a dialog box appears, indicating the success of the build.

2. Click the **Transfer** button in the dialog box.

---

**Note:** When transferring the project to the PLC, you may get a Software mismatch warning message. If no important software exists in the PLC, you can ignore the warning and click **OK**. See B&R documentation for more information on the message.

---

## Forcing values

When Automation Studio is set to Monitor mode, the window can be used to force values to the control word and speed reference variables.

1. To open the I/O Mapping window, right-click the REPL-02 module entry in the Project Explorer window, and then click **Open I/O Mapping** in the pop-up menu.

2. In the View menu, select **Monitor**.

Automation Studio is now in the Monitor mode.

3. To force control word and reference speed values, check the respective check boxes in the Force column, and enter the values in the Force Value column. To start the drive, you could enter values 16#4FF, 16#47E, 16#47F for the control word, and, for example, 10000 for the reference.

# Mechanical installation

---

## What this chapter contains

This chapter contains placing and mounting instructions for the module.



---

**WARNING!** Follow the safety instructions given in this manual and in the appropriate drive hardware manual.

---

## Mounting

The REPL-02 module is to be inserted into its specific position in the drive. The module is held in place with plastic retaining clips and two screws. The screws also provide the earthing of the CAT 5 STP cable shield connected to the module, and interconnect the GND signals of the module and the control board of the drive.

On installation of the module, the signal and power connection to the drive is automatically made through a 34-pin connector.

Mounting procedure:

- Insert the module carefully into its position inside the drive until the retaining clips lock the module into position.
- Fasten the two screws (included) to the stand-offs.

**Note:** Correct installation of the screws is essential for fulfilling the EMC requirements and for proper operation of the module.



# Electrical installation

---

## What this chapter contains

This chapter contains

- general cabling instructions
- Ethernet POWERLINK connections.



**WARNING!** Before installation, switch off the drive power supply. Wait 5 minutes to ensure that the capacitor bank of the drive is discharged. Switch off all dangerous voltages connected from external control circuits to the inputs and outputs of the drive.

---

## General cabling instructions

Arrange the bus cables as far away from the motor cables as possible. Avoid parallel runs. Use bushings at cable entries.

## Ethernet POWERLINK connections

- Connect the cable from the master to upper network connector X1 of the REPL-02 module.
- In the line or a redundant ring network topology, connect the next slave device to the lower network connector X2.
- In a redundant ring topology, connect X2 of the last slave device to the second port of the master.

Use standard CAT 5 UTP, CAT 5 FTP or CAT 5 STP cables. If CAT 5 STP is used, the cable shield is internally connected to the drive frame through the module.

## Node address selection

The REPL-02 is equipped with an 8-bit DIP switch S1. The switch is used to select the node address used for Ethernet POWERLINK communication. The switch settings override the settings of the REPL-02 configuration parameter 3 (NODE ID).

DIP actuators 1 to 8 define the node address in binary. Actuator 8 represents the least significant bit.

For example, DIP switch settings for the node address 20 (00010100bin) can be seen below.

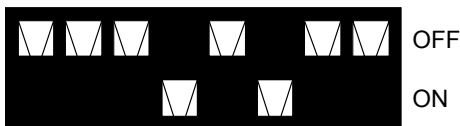

## Ethernet POWERLINK network topology

REPL-02 supports 100 Mbit/s Ethernet POWERLINK.

An Ethernet POWERLINK network may have a star, tree, daisy chain or ring structure. The network can also be a combination of these topologies. If hubs are needed, use class 2 hubs. Repeating types instead of switches are recommended to minimize delay and jitter.

REPL-02 has an internal repeating hub and thus no external hub is required for chaining the link between the REPL-02 modules. The figure below illustrates all possible network topologies for the nodes with REPL-02.

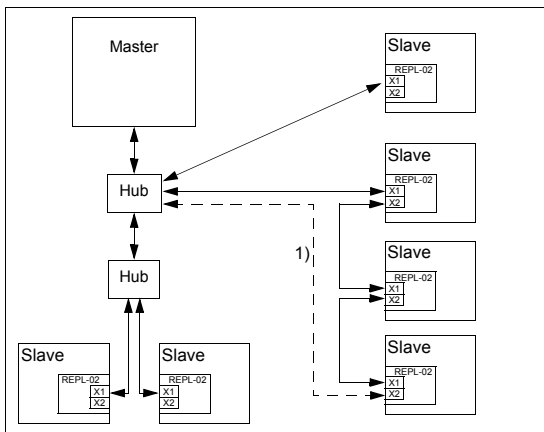

1) Required for a ring topology.



# Drive configuration

---

## What this chapter contains

This chapter gives information on configuring the drive for operation with the REPL-02 Ethernet POWERLINK Adapter module.

## REPL-02 configuration

After the REPL-02 Ethernet POWERLINK Adapter module has been mechanically and electrically installed according to the instructions in chapters [Mechanical installation](#) and [Electrical installation](#), the drive must be prepared for communication with the module.

ABB drives can receive control information from multiple sources including digital inputs, analogue inputs, the drive control panel and a communication module (e.g. REPL-02). ABB drives allow the user to separately determine the source for each type of control information (Start, Stop, Direction, Reference, Fault Reset, etc.). In order to give the fieldbus master station the most complete control over the drive, the communication module must be selected as source for this information. The detailed procedure of activating the drive for communication with the module is dependent on the drive type. Normally, a parameter must be adjusted to activate the communication. Please refer to the drive documentation.

As communication between the drive and the REPL-02 is established, several configuration parameters are copied to the drive. These parameters must be checked first and adjusted if necessary (see table [The REPL-02 configuration parameters on page 32](#)). The alternative selections for these parameters are discussed in more detail below.

---

**Note:** The new settings take effect only when the module is powered up the next time or when the module receives a 'Fieldbus Adapter parameter refresh' (Drive parameter 51.27) command from the drive.

---

### The REPL-02 configuration parameters

Par. no.	Parameter name	Alternative settings	Default setting
1	MODULE TYPE	(Read-only)	POWERLINK or Fieldbus
2	TRANSPARENT/ PROFILE MODE	(0) Profile mode (DSP 402) (1) Transparent mode (ABB Drives)	(0) Profile mode (DSP 402)
3	NODE ID	1 to 239	1

#### 1 MODULE TYPE

This parameter shows the module type as detected by the drive. The value cannot be adjusted by the user.

If this parameter is undefined, the communication between the drive and the module has not been established.

#### 2 TRANSPARENT/PROFILE MODE

This parameter is used for choosing either the transparent (ABB Drives) or the DSP 402 communication profile. This selection can also be changed with object 0×2004 (hex).

#### 3 NODE ID

Selects the node address of the module (1...239). Each device on the Ethernet POWERLINK network must have a unique node address (NODE ID). This parameter is used for defining a node address for the drive it is connected to.

---

**Note:** If the node address is set via DIP switch S1, this parameter is read-only. See chapter [Electrical installation](#).

---

# Master configuration

---

## What this chapter contains

This chapter gives information on configuring the Ethernet POWERLINK master to communicate with the REPL-02 Ethernet POWERLINK Adapter module.

## Configuring the system

After the REPL-02 has been mechanically and electrically installed according to the instructions in previous chapters and initialized by the drive, the master system must be prepared for communication with the module.

Please refer to the master system documentation for more information.

## XML Device Description Files

XML Device Description Files (XDD) are XML files that specify the properties of the slave device for the Ethernet POWERLINK master. The description files contain information on the supported communication objects. XDD files for ABB Drives are available through your local ABB representative and the ABB Library ([www.abb.com](http://www.abb.com)).



# Communication profiles

---

## What this chapter contains

This chapter describes the communication profiles used in the communication between the Ethernet POWERLINK network, the REPL-02 module, and the drive.

## Communication profiles

Communication profiles are ways of conveying control commands (Control Word, Status Word, references and actual values) between the master station and the drive.

With the REPL-02 module, either the CANopen DSP 402 (Device Profile Drives and Motion Control) profile or the ABB Drives profile may be employed. The Control Word, Status Word, references and actual values of these profiles are described in the following sections.

## The CANopen device profile DSP 402

This section describes the basic functionality of the DSP 402 profile. The DSP 402 is a standardized device profile used for digital controlled motion products (e.g. frequency converters) and is part of the CANopen specification. Additional information can be obtained from [www.can-cia.org](http://www.can-cia.org).

## Device Control state machine

The start and stop of the drive and several mode specific commands are executed by the Device Control state machine. This is described in figure [State machine, DSP 402 communication profile](#) on [page 40](#). The Control Word is the principal means for controlling the drive from a fieldbus system. The fieldbus master sends it to the drive through the adapter module. The drive switches between its states according to the bit-

coded instructions in the Control Word, and returns status information to the master in the Status Word.

## Supported mode of operation

The DSP 402 profile offers a choice of several modes of operation. These modes define the operation of the drive. The REPL-02 supports the Velocity mode, which is a basic operation mode used to control the velocity of the drive.

## Control Word and Status Word of the DSP 402 profile

The functionality of the Control Word is described in tables *Control Word of DSP 402* below and *Operation of bits 0...3 and 7 of the DSP 402 Control Word* on [page 37](#). The functionality of the Status Word is described in table *Status Word of DSP 402* on [page 38](#). The Control Word can be found in object 0x6040 (hex) and the Status Word in object 0x6041 (hex) (see chapter *CANopen object dictionary* [page 59](#)).

### Control Word of DSP 402

Bit	Name	Value	Description
0	Switch ON		The functionality of bits 0...3 and 7 are described in table <i>Operation of bits 0...3 and 7 of the DSP 402 Control Word</i> on <a href="#">page 37</a> .
1	Enable voltage		
2	Quick stop		
3	Enable operation		
4	Ramp function generator enable.	0	Force ramp function generator output to zero. Drive ramps to stop (current and DC voltage limits in force).
		1	<b>Normal operation:</b> Velocity reference is the output value of the ramp function generator.
5	Ramp function generator unlock.	0	Ramp function generator output value is locked to the current output value.
		1	<b>Normal operation:</b> Ramp output value follows ramp input value.

Bit	Name	Value	Description
6	Ramp function generator use ref.	0	Ramp function generator input value is set to zero.
		1	<b>Normal operation:</b> Ramp function generator input is the ramp reference.
7	Fault reset		The functionality of bits 0...3 and 7 are described in table <a href="#">Operation of bits 0...3 and 7 of the DSP 402 Control Word</a> .
8	Halt (not used)		
9...10	Reserved		
11...15	Drive specific (not used)		

#### Operation of bits 0...3 and 7 of the DSP 402 Control Word

Command	Control Word bit					State transitions *
	Fault reset bit 7	Enable operation bit 3	Quick stop bit 2	Enable voltage bit 1	Switch on bit 0	
Shut down	0	X	1	1	0	2, 6, 8
Switch on	0	0	1	1	1	3
Switch on	0	1	1	1	1	3 (+4)**
Disable voltage	0	X	X	0	X	7, 9, 10, 12
Quick stop	0	X	0	1	X	7, 10, 11
Disable operation	0	0	1	1	1	5
Enable operation	0	1	1	1	1	4
Fault reset		X	X	X	X	15

X: Bits marked with X are irrelevant

\* See figure [State machine, DSP 402 communication profile](#) on [page 40](#).

\*\* When Control Word bit 3 (Enable operation) is 1, the drive does not stay in the SWITCHED ON state, but immediately transitions to state OPERATION ENABLED.

### Status Word of DSP 402

Bit	Name	Value	Description
0	Ready to switch ON	0	Not ready to switch ON
		1	Ready to switch ON
1	Switched ON	0	Not switched ON
		1	Switched ON
2	Operation enabled	0	Operation not enabled
		1	Operation enabled
3	Fault	0	No fault
		1	Fault
4	Voltage enabled	0	No high voltage applied to drive
		1	High voltage applied to drive
5	Quick stop	0	Quick stop is active
		1	Normal operation
6	Switch on disabled	0	Switch on enabled
		1	Switch on disabled
7	Warning	0	No warning/alarms
		1	Warning/Alarm is active
8	Drive specific	0	ACx550: No External Run Enable signal received
		1	ACx550: External Run Enable signal received ACS800: User settable*
9	Remote	0	Drive control location: REMOTE (EXT1 or EXT2)
		1	Drive control location: LOCAL
10	Target reached	0	Actual value equals reference
		1	Actual value differs from reference
11	Internal limit active	0	Internal limit not active

Bit	Name	Value	Description
		1	Internal limit active
12...13	Reserved		
14	Drive specific	0	ACx550: External control location EXT1 selected
		1	ACx550: External control location EXT2 selected ACS800: User settable*
15	Drive specific	0	ACx550: Not used ACS800: User settable*

\* The functionality of the vendor-specific bits in ACS800 can vary according to the control program. In the Standard control program the bits are configured with drive parameters 92.07, 92.08 and 92.09.

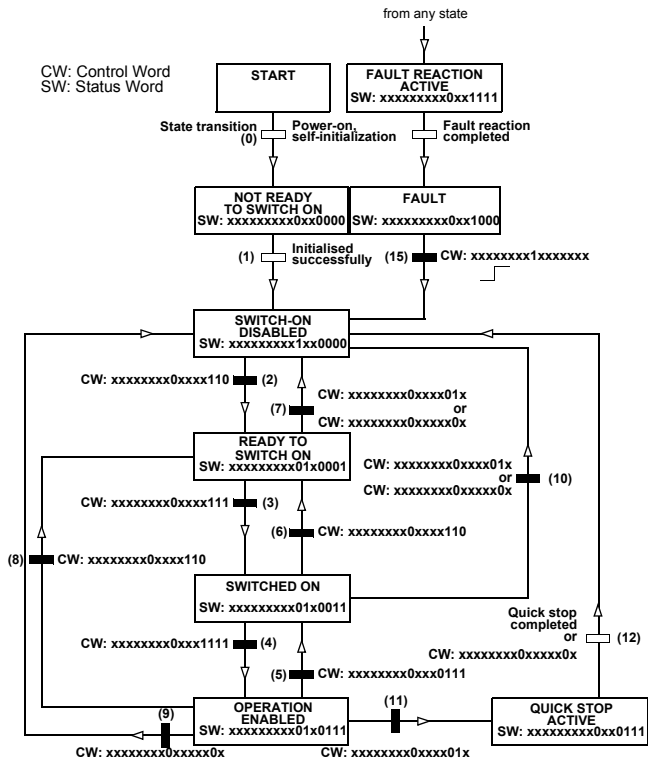

## Reference of the DSP 402 profile

In the velocity operation mode, the reference is called Target velocity (object 0x6042 hex). It is a 16-bit word containing a sign bit and a 15-bit integer. A negative reference (indicating reversed direction of rotation) is formed by calculating the two's complement from the corresponding positive reference. The reference is used to control the speed of the drive.

The unit of the target velocity is rpm. This value can be scaled with the VI dimension factor object (object 0x604C hex):

Reference to drive = Target velocity × VI dimension factor

The scaling is 1 by default.

## Actual value of the DSP 402 profile

In the velocity operation mode, the actual value is called Control effort (object 0x6044 hex). It is a 16-bit word containing a sign bit and a 15-bit integer. A negative actual value (indicating reversed direction of rotation) is formed by calculating the two's complement from the corresponding positive actual value. The actual value is used by the master to monitor the actual speed of the drive.

The unit of the control effort is rpm. This value can be scaled with the VI dimension factor object (object 0x604C hex):

Drive actual speed = Control effort × VI dimension factor

The scaling is 1 by default.

## ABB Drives communication profile

### The Control Word and the Status Word

The Control Word is the principal means for controlling the drive from a fieldbus system. It is sent by the fieldbus master station to the drive through the adapter module. The drive switches between its states according to the bit-coded instructions on the Control Word, and returns status information to the master in the Status Word.

The contents of the Control Word and the Status Word are detailed in tables *Control Word of ABB Drives profile* and *Status Word of the ABB Drives profile* respectively. The drive states are presented in the ABB Drives profile state machine (see figure *State machine, ABB Drives communication profile* on page 46). The ABB Drives profile Control Word can be found in object 0x2005 (hex) (Transparent Control Word) and the Status Word in object 0x2007 (hex) (Transparent Status Word).

### Control Word and Status Word of the ABB Drives profile

The following table presents the Control Word of the ABB Drives communication profile. The upper case boldface text refers to the states shown in figure *State machine, ABB Drives communication profile* on page 46.

#### Control Word of ABB Drives profile

Bit	Name	Value	STATE/Description
0	OFF1_ CONTROL	1	Proceed to <b>READY TO OPERATE</b> .
		0	Stop along currently active deceleration ramp. Proceed to <b>OFF1 ACTIVE</b> ; proceed to <b>READY TO SWITCH ON</b> unless other interlocks (OFF2, OFF3) are active.
1	OFF2_ CONTROL	1	Continue operation (OFF2 inactive).
		0	Emergency OFF, coast to stop. Proceed to <b>OFF2 ACTIVE</b> , proceed to <b>SWITCH-ON INHIBITED</b> .
2	OFF3_ CONTROL	1	Continue operation (OFF3 inactive).
		0	Emergency stop, stop within time defined by drive parameter. Proceed to <b>OFF3 ACTIVE</b> ; proceed to <b>SWITCH-ON INHIBITED</b> . <b>Warning:</b> Ensure motor and driven machine can be stopped using this stop mode.

## Control Word of ABB Drives profile

Bit	Name	Value	STATE/Description
3	INHIBIT_ OPERATION	1	Proceed to <b>OPERATION ENABLED</b> . <b>Note:</b> Run enable signal must be active; see the drive manuals. If the drive is set to receive the Run enable signal from the fieldbus, this bit activates the signal.
		0	Inhibit operation. Proceed to <b>OPERATION INHIBITED</b> .
4	RAMP_OUT_ ZERO	1	Normal operation. Proceed to <b>RAMP FUNCTION GENERATOR: OUTPUT ENABLED</b> .
		0	Force Ramp Function Generator output to zero. Drive ramps to stop (current and DC voltage limits in force).
5	RAMP_HOLD	1	Enable ramp function. Proceed to <b>RAMP FUNCTION GENERATOR: ACCELERATOR ENABLED</b> .
		0	Halt ramping (Ramp Function Generator output held).
6	RAMP_IN_ ZERO	1	Normal operation. Proceed to <b>OPERATING</b> . <b>Note:</b> Effective only if the fieldbus interface is set as the source for this signal by drive parameters.
		0	Force Ramp Function Generator input to zero.
7	RESET	0=>1	Fault reset if an active fault exists. Proceed to <b>SWITCH-ON INHIBITED</b> . <b>Note:</b> Effective only if the fieldbus interface is set as the source for this signal by drive parameters.
		0	Continue normal operation.
8 to 9	Reserved.		

**Control Word of ABB Drives profile**

Bit	Name	Value	STATE/Description
10	REMOTE_CMD	1	Fieldbus control enabled
		0	Control Word <> 0 or Reference <> 0: Retain last Control Word and Reference. Control Word = 0 and Reference = 0: Fieldbus control enabled. Reference and deceleration/acceleration ramp are locked.
11	EXT_CTRL_LOC	1	Select External Control Location EXT2. Effective if control location is parameterised to be selected from fieldbus.
		0	Select External Control Location EXT1. Effective if control location is parameterised to be selected from fieldbus.
12 to 15	Reserved		

The following table presents the Status Word of the ABB Drives communication profile. The upper case boldface text refers to the states shown in figure [State machine, ABB Drives communication profile](#) on [page 46](#).

**Status Word of the ABB Drives profile**

Bit	Name	Value	STATE/Description
0	RDY_ON	1	<b>READY TO SWITCH ON</b>
		0	<b>NOT READY TO SWITCH ON</b>
1	RDY_RUN	1	<b>READY TO OPERATE</b>
		0	<b>OFF1 ACTIVE</b>
2	RDY_REF	1	<b>OPERATION ENABLED</b>
		0	<b>OPERATION INHIBITED</b>
3	TRIPPED	1	<b>FAULT</b>
		0	No fault

**Status Word of the ABB Drives profile**

Bit	Name	Value	STATE/Description
4	OFF_2_STA	1	OFF2 inactive
		0	<b>OFF2 ACTIVE</b>
5	OFF_3_STA	1	OFF3 inactive
		0	<b>OFF3 ACTIVE</b>
6	SWC_ON_INHIB	1	<b>SWITCH-ON INHIBITED</b>
		0	–
7	ALARM	1	Warning/Alarm
		0	No warning/alarm
8	AT_SETPOINT	1	<b>OPERATING.</b> Actual value equals reference = is within tolerance limits, i.e. in speed control, speed error is 10% max. of the nominal motor speed.
		0	Actual value differs from reference = is outside tolerance limits.
9	REMOTE	1	Drive control location: REMOTE (EXT1 or EXT2)
		0	Drive control location: LOCAL
10	ABOVE_LIMIT	1	Actual frequency or speed equals or exceeds supervision limit (set by drive parameter). Valid in both directions of rotation.
		0	Actual frequency or speed within supervision limit
11	EXT_CTRL_LOC	1	External Control Location EXT2 selected
		0	External Control Location EXT1 selected
12	EXT_RUN_ENABLE	1	External Run Enable signal received
		0	No External Run Enable signal received
13 to 14	Reserved		
15		1	Communication error detected by fieldbus adapter module
		0	Fieldbus adapter communication OK

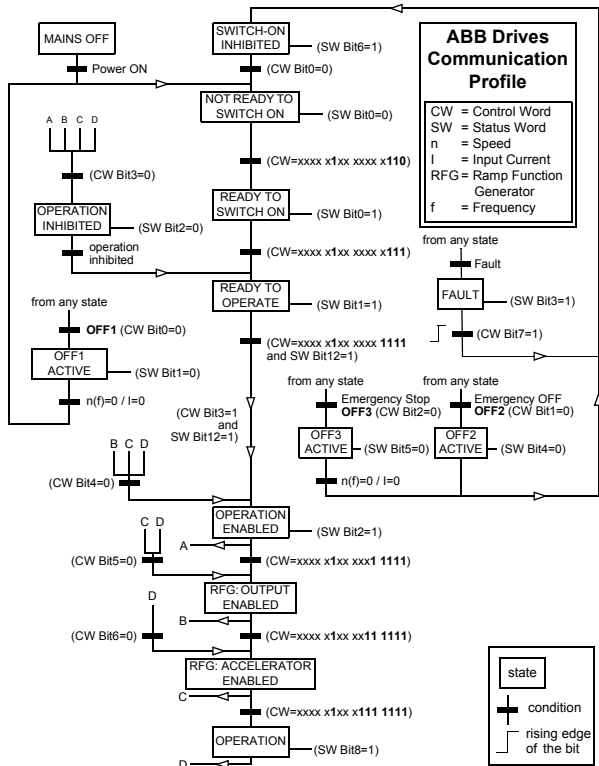

Figure 5. State machine, ABB Drives communication profile

## References

References are 16-bit words containing a sign bit and a 15-bit integer. A negative reference (indicating reversed direction of rotation) is formed by calculating the two's complement of the corresponding positive reference. The ABB Drives profile reference can be found in objects 0×2006 (hex) (Transparent Reference) and 0×4000 (hex), subindex 3 (Reference 2).

ABB drives can receive control information from multiple sources including analogue and digital inputs, the drive control panel and a communication module (e.g. REPL-02). In order to have the drive controlled through the fieldbus, the module must be defined as the source for control information, e.g. reference.

## Scaling

References are scaled as shown below.

**Note:** The values of REF1 MAX and REF2 MAX are set by drive parameters. See the drive manuals for further information.

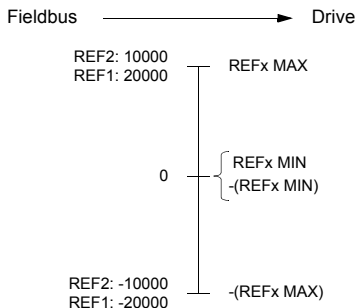

## Actual values

Actual values are 16-bit words containing information on the operation of the drive. The functions to be monitored are selected by a drive parameter. Negative actual values are formed by calculating the two's complement from the corresponding positive actual values. The ABB Drives profile actual values can be found in objects 0x2008 (hex) (Transparent Actual Value) and 0x4000 (hex), subindex 6 (Actual Value 2).

## Scaling

Actual values are scaled as shown below.

**Note:** The values of REF1 MAX and REF2 MAX are set by drive parameters. See the drive manuals for further information.

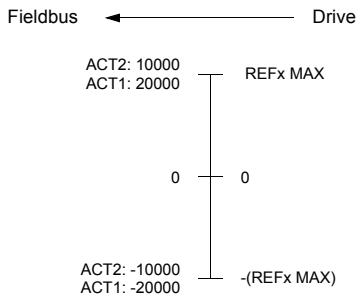

# Communication

## What this chapter contains

This chapter describes the communication on an Ethernet POWERLINK network.

## Ethernet POWERLINK communication cycle

In an Ethernet POWERLINK network, one of the nodes, for example a PLC, motion controller or industrial PC, is designated to function as the Managing Node (MN), the master in the network. All other devices operate as Controlled Nodes (CN), slaves in the network. The MN defines the clock pulse for the synchronization of all devices and manages the data communication cycle. In the course of one clock cycle within which all nodes are addressed, the MN sends Poll Requests (PReq) to all CNs one after another. They reply immediately to the prompts with Poll Responses (PRes).

An Ethernet POWERLINK cycle consists of three phases. During the start phase, the MN sends a Start of Cycle Frame (SoC) signal to all CNs to synchronize the devices. Payload data exchange then proceeds in the second phase, the isochronous phase. The third phase, the asynchronous phase, allows the transfer of large packets that are not time-critical, for example parametrization data.

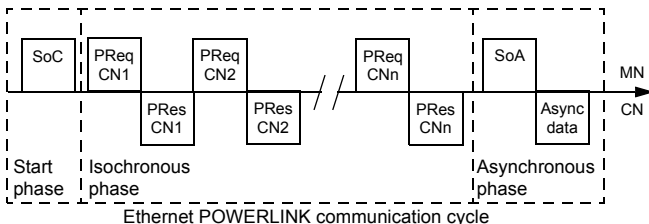

## Ethernet POWERLINK state machine

In Ethernet POWERLINK, a Controlled Node starts up by a common initialization process. All the states are valid when the device is powered and they are sub-states of the NMT\_GS\_POWERED superstate.

### NMT\_GS\_INITIALISATION

After system start, the device automatically assumes this state and network functionality begins. NMT\_GS\_INITIALISATION and all its sub-states are only internal states of the device.

In the NMT\_GS\_RESET\_CONFIGURATION sub-state, the node address of the device is identified and it is determined whether it is configured as a MN or CN. The REPL-02 is a CN and thus, it enters the NMT\_CN state machine in the NMT\_GS\_COMMUNICATING super-state.

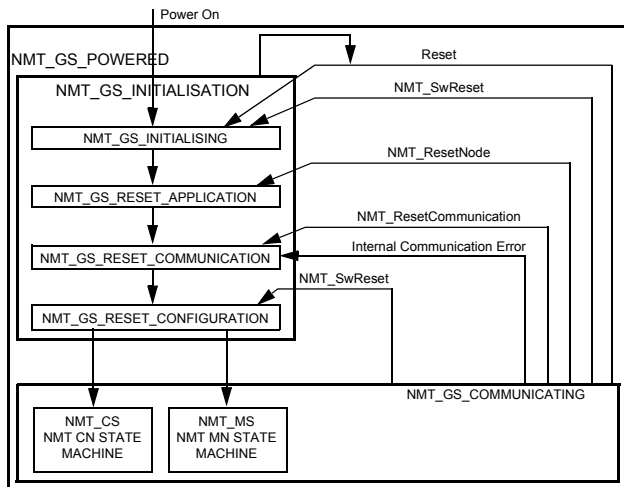

## **NMT\_GS\_COMMUNICATING**

### *NMT\_CS\_NOT\_ACTIVE*

This is a non-permanent state that allows a starting node to recognize the current network state. Timeout for SoC, PReq, PRes and SoA frames trigger the device to enter state NMT\_CS\_BASIC\_ETHERNET.

### *The NMT\_CS\_PREOPERATIONAL states*

NMT\_CS\_PREOPERATIONAL\_1 is one of the sub-states in the superstate NMT\_CS\_EPL\_MODE. Transition from NMT\_CS\_NOT\_ACTIVE to NMT\_CS\_PRE\_OPERATIONAL\_1 is triggered by a SoA or SoC frame being received. In this state CN may send a frame only if the MN has authorized it to do so by a SoA command. There is no PDO communication in this state.

Receiving a SoC frame triggers the transition from NMT\_CS\_PREOPERATIONAL\_1 to NMT\_CS\_PREOPERATIONAL\_2. In this state PReq and PRes data may be invalid because PDO mappings may differ.

In NMT\_CS\_EPL\_MODE, error recognition (for example, loss of SoC or PReq) always triggers the transition to NMT\_CS\_PREOPERATIONAL\_1.

### *NMT\_CS\_READY\_TO\_OPERATE*

In this state, the CN signals that it is ready to operate to the MN. It responds to the PReq query of the MN by sending a PRes frame.

### *NMT\_CS\_OPERATIONAL*

NMT StartNode command triggers the transition from NMT\_CS\_READY\_TO\_OPERATE to the NMT\_CS\_OPERATIONAL. This is the normal operating state of the CN.

### *NMT\_CS\_STOPPED*

This state is used for controlled shutdown of a selected CN while the system is still running. In this state, the CN does not participate in cyclic frame exchange, but it still observers SoA frames.

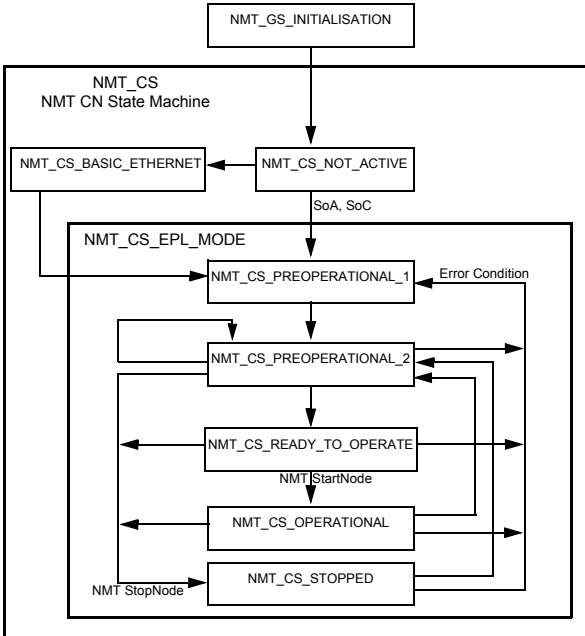

## DS 301 and DS 402 specification

The application layer communication protocol in REPL-02 is based on the CANopen DS 301 communication profile and DS 402 device profile for drives and motion control. The protocol specifies the Object Dictionary in the module, as well as communication objects for exchanging process data and acyclic messages.

REPL-02 implements the following message types:

- Process Data Object (PDO)
  - The PDO object is used for cyclic I/O communication, i.e. process data.
- Service Data Object (SDO)
  - The SDO object is used for acyclic data transmission.
- NMT response services
  - Used for identity and status signalling both during the start-up and in runtime.

The object dictionary is described in chapter *CANopen object dictionary* on page 59.

### Process Data Objects (PDO)

Process Data Objects (PDOs) are used for exchanging time-critical process data between the master and the slave. Tx PDOs are used to transfer data from the slave to the master and Rx PDOs to transfer data from the master to the slave.

PDO mapping defines which application objects are transmitted inside a PDO. These typically include the Control and Status Words, References and Actual Values, but most dictionary objects and drive parameters can be mapped for cyclical communication.

The REPL-02 has one receive PDO (Rx PDO) and one transmit PDO (Tx PDO). In each PDO, 0...16 application objects can be mapped. PDOs are mapped to objects during configuration (the NMT\_CS\_PRE-OPERATIONAL\_1 and NMT\_CS\_PRE-OPERATIONAL\_2 states).

The Tx PDO is mapped by writing to the 0x1A00 object. By default, there is no parameter mapped to the Tx PDO. Choose which parameters are exchanged by the Tx PDO.

The Rx PDO is mapped by writing to the 0x1600 object. By default, there is no parameter mapped to the Rx PDO. Choose which parameters are exchanged by the Rx PDO.

---

**Note:** The maximum number of I/O parameters that can be simultaneously mapped for cyclic communication depends on the drive type and application. For example, ACS800 supports 12 inputs and 12 outputs, and ACS550 supports 15 outputs and 15 inputs.

---

## Service Data Objects (SDOs)

SDO (Service Data Object) uses asynchronous data transmission and is used to access object without mapping them to a PDO connection. With SDO communication, all CANopen objects in the REPL-02 can be accessed.

Ethernet POWERLINK provides different kinds of SDO transfer methods. REPL-02 supports SDO transfer via Ethernet POWERLINK ASnd frames in asynchronous phase. For further information, see Ethernet POWERLINK Communication Profile Specification Version 1.1.0.

### SDO Protocol

The Download Protocol (for write commands) and Upload Protocol (for read commands) are described in the Ethernet POWERLINK Communication Profile Specification Version 1.1.0. REPL-02 supports the following commands:

- Write by Index
- Read by Index

When the Write by Index command is used, the client of an SDO (the MN) downloads data to the REPL-02.

When the Read by Index command is used, the client of an SDO (the MN) requests the REPL-02 to upload data to the client.

To address the objects, Indexes and Sub-Indexes are used. An Index (0...65535) specifies an entry of the device object and a Sub-Index (0...254) specifies a component of the device object dictionary entry.

## Network Management Services

Ethernet POWERLINK Network Management (NMT) is node-oriented and follows a master/slave relationship. REPL-02 is administered as an NMT slave by the master.

Ethernet POWERLINK defines five categories of NMT services:

- NMT State Command Services
- NMT Managing Command Services (not supported)
- NMT Response Services
- NMT Info Services (not supported)
- NMT Guard Services (not supported)

### NMT State Command Services

The MN controls the state of the CN via NMT State Command Services. See section [Ethernet POWERLINK state machine](#) for more information.

### NMT Response Services

NMT Response Services are used by the MN to query NMT information from the CN, such as current state, error and setup data. Ethernet POWERLINK specifies the following NMT Response Services:

- NMT State Response
- IdentResponse
- StatusResponse

Via NMT State Response service, the CNs signal their states to the MN. IdentResponse Service is used by the MN to identify configured but unrecognized CNs at system start-up or after loss of communication. See [Appendix: IdentResponse Frame](#) for more information.

The StatusResponse Service is used by the MN to query the current status of CNs that are not communicating isochronously. It is used for error signalling in runtime. If an error occurs, the EN (Error New) flag in the PRes frame is toggled. This notifies the MN that an error has occurred and the MN polls the CN for a StatusResponse that includes error information. A list of active and historical error events can be read using SDO from object 0x1003.

#### *Error entry specification*

<b>Byte</b>	0	1	2	3	4	5	6	7	8	9
	Entry type*		Error code**		Time stamp (Not used***)					
<b>Byte</b>	10	11	12	13	14	15	16	17	18	19
	Time stamp		Additional information (Not used***)							

\* See Ethernet POWERLINK Communication Profile Specification, version 1.1.0.

\*\* See the error code table in appendix Emergency messages, DS301 & DS402.

\*\*\* All bytes are set to zero.

## Diagnostics

---

### LED indications

The REPL-02 module is equipped with four diagnostic LEDs. The description of the LEDs is presented below.

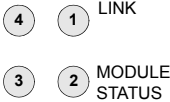
	ACTIVITY	
	ERROR	
Name		Function
LED 1: LINK	<b>Off:</b> No link	
	<b>Green:</b> Module is connected to Ethernet	
The <b>green</b> MODULE STATUS LED indicates the status of the Ethernet POWERLINK network state machine.		
LED 2: MODULE STATUS	<b>Off:</b> NMT_GS_OFF, NMT_GS_INITIALISATION or NMT_CS_NOT_ACTIVE	
	<b>Flickering:</b> (On 50 ms, off 50 ms) NMT_CS_BASIC_ETHERNET	
	<b>Green Single flash:</b> NMT_CS_PRE_OPERATIONAL_1	
	<b>Green Double flash:</b> NMT_CS_PRE_OPERATIONAL_2	
	<b>Green Triple flash:</b> NMT_CS_READY_TO_OPERATE	
	<b>Green On:</b> NMT_CS_OPERATIONAL	
	<b>Green Blinking:</b> (On 200 ms, off 200 ms) NMT_CS_STOPPED	

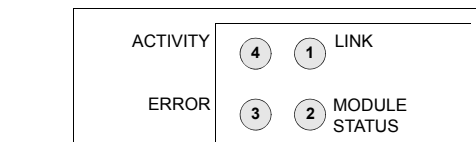

The <b>red</b> ERROR LED indicates the presence of any errors.	
LED 3: ERROR	<b>Off:</b> Normal operation <b>On:</b> An error has occurred.
LED 4: ACTIVITY	<b>Off:</b> No traffic <b>Flickering:</b> (On 50 ms, off 50 ms) There is traffic on Ethernet

# CANopen object dictionary

---

## Overview

The CANopen Object Dictionary contains all the configuration data of the REPL-02 module. The objects in the dictionary can be accessed with SDO services, and many of the dictionary objects can be mapped for cyclic communication in PDOs. Each object is addressed using a 16-bit index.

## Communication profile objects

The objects in the communication profile section describe the basic Ethernet POWERLINK properties of the module. The objects are described in following table [Communication profile objects](#).

**Communication profile objects**

Index (hex)	Sub-index	Name	Type	Attribute	Information
0×1000	0	Device type	U32	RO	Describes the type of the device. Composed of two 16-bit fields (one for device profile, the other for additional information). The object value of the REPL-02 is 0×0192 (hex), which corresponds to drive profile DSP 402 (0×192 hex), and to additional information <i>Frequency Converter</i> (0×01 hex).
0×1001	0	Error register	U8	RO	
0×1003	0	Error history	U8	RW	Number of entries. 0 = clear history
	1	Error entry 1		RO	
	...			...	
	5	Error entry 5		RO	

<b>Index (hex)</b>	<b>Sub-index</b>	<b>Name</b>	<b>Type</b>	<b>Attribute</b>	<b>Information</b>
0x1006	0	Communication cycle time interval	U32	RW*	
0x1008	0	Manufacturer device name	Visible string	RO	Device name. The constant string is REPL-02 and ACxxxx.
0x1009	0	Manufacturer hardware version	Visible string	RO	The hardware version of the module.
0x100A	0	Manufacturer software version	Visible string	RO	The software version. Format: v x.yy

Index (hex)	Sub-index	Name	Type	Attribute	Information
0x1010	0	Store parameters	U8	RO	Largest supported subindex. If the value of bit 0 of the subindexes is 1, the device saves parameters on command. Parameters can be saved by writing 0x65766173 ("evas") to the relevant subindex.
	1	Save all parameters	U32	RW	Stores all parameters to memory.
	2	Save communication (objects 0x1000 ... 0x1A16) parameters	U32	RW	Communication parameters are not stored in the module.
	3	Save drive profile (objects 0x603F... 0x60FE, 0x2001... 0x200B) parameters	U32	RW	All profile parameters are saved.
	4	Save drive parameters	U32	RW	Store drive parameters.

Index (hex)	Sub-index	Name	Type	Attribute	Information
0x1011	0	Restore default parameters	U8	RO	Largest supported subindex. Default parameters can be restored by writing 0x64616F6C ("daol") to the relevant sub index.
	1	Restore all parameters	U32	RW	Restore all parameters.
	2	Restore communication (objects 0x1000... 0x1A16) parameters	U32	RW	Communication parameters are not stored on the module.
	3	Restore drive profile (objects 0x603F... 0x60FE, 0x2001... 0x200B) parameters	U32	RW	Restore all DSP 402 parameters.
	4	Restore drive parameters	U32	RW	Restore drive default parameters.
0x1018	0	Identity object	U8	RO	Number of entries
	1	Vendor ID	U32	RO	Value: 0xB7 = ABB (Oy)
	2	Product code	U32	RO	Drive dependent, e.g. 0x201 = ACS550
	3	Revision	U32	RO	Module software revision. Format: 0XXXX.YYYY
	4	Serial number	U32	RO	Serial number of the module.

Index (hex)	Sub-index	Name	Type	Attribute	Information
0×1020	0	Verify configuration	U8	RO	Number of entries
	1	Configuration date	U32	RW*	Used by the MN to verify if the module is properly configured.
	2	Configuration time	U32	RW*	Used by the MN to verify if the module is properly configured.
0×1030	0	Interface Group	U8	RO	Number of entries. Always 9.
	1	Interface Index	U32	RO	1
	2	Interface Description	Visible string	RO	ABB REPL-02 HW 1.0
	3	Interface Type	U8	RO	6 (Ethernet CSMA/CD)
	4	Interface Mtu	U16	RO	
	5	Interface Phys Address	Octet string	RO	MAC address assigned during manufacturing.
	6	Interface Name	Visible string	RO	Always eth0.
	7	Interface Operation Status	U8	RO	
	8	Interface admin state	U8	RW	
	9	Valid Boolean	BOOL	RW	
0×1300	0	SDO sequence timeout	U32	RW*	
0×1400	0	Receive PDO Communication	U8	RO	Number of entries. Always 2.
	1	Node ID	U8	RW	
	2	Mapping version	U8	RW	

Index (hex)	Sub-index	Name	Type	Attribute	Information
0×1600	0	Receive PDO Mapping	U8	RW	Number of mapped application objects (0...32). See also the note in <i>Process Data Objects (PDO)</i> for information on drive support.
	1	Mapped object #1	U64	RW	
	n	Mapped object #n	U64	RW	
0×1800	0	Transmit PDO Communication	U8	RO	Number of entries. Always 2.
	1	Node ID	U8	RW	
	2	Mapping version	U8	RW	
0×1A00	0	Transmit PDO Mapping	U8	RW	Number of mapped application objects (0...32). See also the note in <i>Process Data Objects (PDO)</i> for information on drive support.
	1	Mapped object #1	U64	RW	
	n	Mapped object #n	U64	RW	
0×1C0B	0	Loss of SoC	U8	RO	Number of entries. Always 3.
	1	Cumulative count	U32	RW	
	2	Threshold count	U32	RO	
	3	Threshold	U32	RW	
0×1C0D	0	Loss of PReq	U8	RO	Number of entries. Always 3.

Index (hex)	Sub-index	Name	Type	Attribute	Information
	1	Cumulative count	U32	RW	
	2	Threshold count	U32	RO	
	3	Threshold	U32	RW	
0x1C0F	0	CRC errors	U8	RO	Number of entries. Always 3.
	1	Cumulative count	U32	RW	
	2	Threshold count	U32	RO	
	3	Threshold	U32	RW	
0x1C14	0	Loss of frame tolerance	U32	RW	
0x1F82	0	Feature flags	U32	RO	Always 0x45.
0x1F83	0	EPL version	U8	RO	Always 0x20.
0x1F8C	0	Current NMT state	U8	RO	
0x1F93	0	EPL Node ID	U8	RO	Number of entries. Always 2.
	1	Node ID	U8	RO	
	2	Node ID by HW	BOOL	RO	

Index (hex)	Sub-index	Name	Type	Attribute	Information
0×1F98	0	Cycle timing	U8	RO	Number of entries. Always 10.
	1	Isochr Tx Max Payload	U16	RO	
	2	Isochr Rx Max Payload	U16	RO	
	3	Pres Max Latency	U32	RO	
	4	PReq Act Payload Limit	U16	RW*	
	5	Pres Act Payload Limit	U16	RW*	
	6	ASnd Max Latency	U32	RO	
	7	Multiple cycle count	U16	RW*	
	8	Async MTU	U32	RW*	
	9	Prescaler	U8	RW*	
0×1F99	0	Basic Ethernet Timeout	U32	RW*	
0×1F9E	0	Reset command	U8	RW	

\* The value written to this object is valid after reset.

## Manufacturer specific profile objects

The manufacturer specific profile object contains the ABB Drives profile Control and Status Words, Reference and Actual Value. In addition, objects for diagnostic data and PID configuration are included. The objects are described in table [Manufacturer specific profile objects](#) on [page 67](#).

### Manufacturer specific profile objects

Index (hex)	Sub-index	Name	Type	Attribute	Information
0x2004	0	Transparent / Profile mode	U8	RW	An object for choosing the communication profile 0 = Profile mode (DSP 402) 1 = Transparent (ABB Drives) profile mode This object can only be modified in the state PRE-OP2.
0x2005	0	Transparent Control Word	U16	RW	See chapter <i>Communication profiles</i> on page 35.
0x2006	0	Transparent reference	INT16	RW	
0x2007	0	Transparent Status Word	U16	RO	
0x2008	0	Transparent actual feedback	INT16	RO	
0x200A	0	Vendor specific alarm codes	U8	RO	Number of entries See the drive manual for descriptions of the alarm codes.
	1	Alarm code 1 (latest)	U16	RO	
	2	Alarm code 2	U16	RO	
	3	Alarm code 3	U16	RO	
	4	Alarm code 4	U16	RO	
	5	Alarm code 5	U16	RO	

Index (hex)	Sub-index	Name	Type	Attribute	Information
0x200B	0	Vendor specific fault codes	U8	RO	Number of entries See the drive manual for descriptions of the fault codes.
	1	Fault code 1 (latest)	U16	RO	
	2	Fault code 2	U16	RO	
	3	Fault code 3	U16	RO	
	4	Fault code 4	U16	RO	
	5	Fault code 5	U16	RO	

## Drive data sets

With the object 0x4000 (hex) the data set area of the drive can be accessed. The dictionary entry is described in following table [Drive data sets](#) on [page 69](#).

**Note:** The total number of data sets and data words supported depends on the drive type and application program.

### Drive data sets

Index (hex)	Sub-index	Name	Type	Attribute	Information
0x4000	0	Number of entries		RW	Number of supported data sets depends on the application software of the drive.
	1	Control Word	U16	RW	Data set 1 Word 1
	2	Reference 1	INT16	RW	Data set 1 Word 2
	3	Reference 2	INT16	RW	Data set 1 Word 3
	4	Status Word	U16	RO	Data set 2 Word 1
	5	Actual Value 1	INT16	RO	Data set 2 Word 2
	6	Actual Value 2	INT16	RO	Data set 2 Word 3
	7	Reference 3	INT16	RW	Data set 3 Word 1
	8	Reference 4	INT16	RW	Data set 3 Word 2
	9	Reference 5	INT16	RW	Data set 3 Word 3
	A	Actual Value 3	INT16	RO	Data set 4 Word 1
	B	Actual Value 4	INT16	RO	Data set 4 Word 2
	C	Actual Value 5	INT16	RO	Data set 4 Word 3
	...	...	...	...	...
	62	Reference 49	INT16	RW	Data set 32 Word 2
	63	Reference 50	INT16	RW	Data set 32 Word 3

### Drive actual signals and parameters

The actual signals and parameters available depend on the drive type. See the appropriate drive firmware manual for signal and parameter listings.

The Read service is used for reading actual signals and parameters from the drive. The Write service is used for writing parameter values to the drive. Both the Read and Write services

use the same parameter mapping system. The Object Dictionary Index equals drive parameter group in hexadecimal format + 4000 (hex) and the subindex is parameter index. For example, the index for the drive parameter 30.19 equals 1E (hex) + 4000 (hex) = 401E (hex) and the subindex = 19 (dec) = 13 (hex). The principle is demonstrated in following table *Drive signals and parameters*.

**Note:** Drive parameter values written through the network are not automatically saved to the permanent memory of the drive. A parameter save should be initiated in the drive to retain the changes after a power cycle.

### Drive signals and parameters

Index (hex)	Subindex	Name	Type	Attribute	Information
4001	1	Drive signal 1.01	(1)	(2)	(3)
	2	Drive signal 1.02	(1)	(2)	(3)
...	...	...	...	...	...
4002	1	Drive signal 2.01	(1)	(2)	(3)
...	...	...	...	...	...
4003	1	Drive signal 3.01	(1)	(2)	(3)
...	...	...	...	...	...
400A	1	Drive par. 10.01	(1)	(2)	(3)
	2	Drive par. 10.02	(1)	(2)	(3)
...	...	...	...	...	...
400B	1	Drive par. 11.01	(1)	(2)	(3)
...	...	...	...	...	...
4063	1	Drive par. 99.01	(1)	(2)	(3)
...	...	...	...	...	...

Index (hex)	Subindex	Name	Type	Attribute	Information
Subindex 0 = number of mapped objects. <sup>(1)</sup> U16, INT16, U32 or INT32 <sup>(2)</sup> Depends on parameter type of the drive. <sup>(3)</sup> See the appropriate drive firmware manual.					

## DSP 402 profile objects

The DSP 402 profile objects describe objects for monitoring and controlling frequency controllers. The objects are described in the following table *DSP 402 profile objects*.

### DSP 402 profile objects

Index (hex)	Sub-index	Name	Type	Attribute	Information
0×603F	0	Error code	U16	RO	See chapter <i>Emergency messages, DS301 and DS402</i> on page 75
0×6040	0	Controlword	U16	RW	See chapter <i>Communication profiles</i> on page 35
0×6041	0	Statusword	U16	RO	
0×6042	0	VI target velocity	INT16	RW	
0×6043	0	VI velocity demand	INT16	RO	Instantaneous velocity provided by the ramp function. Scaled to the value of the VI target velocity.
0×6044	0	VI velocity actual value	INT16	RO	See chapter <i>Communication profiles</i> on page 35
0×6046	0	VI velocity min max amount	INT8	RO	Number of entries
	1	VI velocity min amount	U32	RW	Velocity minimum amount
	2	VI velocity max amount	U32	RW	Velocity maximum amount

Index (hex)	Sub-index	Name	Type	Attribute	Information
0×6048	0	VI velocity acceleration	INT8	RO	Number of entries Slope of the acceleration ramp = delta speed / delta time.
	1	Delta speed	U32	RW	
	2	Delta time	U16	RW	
0×6049	0	VI velocity deceleration	INT8	RO	Number of entries Slope of the deceleration ramp = delta speed / delta time.
	1	Delta speed	U32	RW	
	2	Delta time	U16	RW	
0×604A	0	VI velocity quick stop	INT8	RO	Number of entries Slope of the deceleration ramp = delta speed / delta time.
	1	Delta speed	U32	RW	
	2	Delta time	U16	RW	
0×604C	0	VI dimensions factor	INT8	RO	Number of entries The dimension factor affects the scaling of other objects (0×6042, 0×6043, 0×6044, 0×6046, 0×6048, 0×6049, 0×604A). The parameter can only be modified in the PRE-OP state.
	1	VI dimensions factor numerator	INT32	RW	The numerator of the scaling factor. Default: 1
	2	VI dimensions factor denominator	INT32	RW	The denominator of the scaling factor. Default: 1
0×6060	0	Modes of operation	INT8	RW	The current mode of operation. Always set to 2 (Velocity mode).

<b>Index (hex)</b>	<b>Sub-index</b>	<b>Name</b>	<b>Type</b>	<b>Attribute</b>	<b>Information</b>
0×6061	0	Modes of operation display	INT8	RO	A read only copy of object 0×6060
0×6078	0	Current actual value	INT16	RO	The actual output current



## Emergency messages, DS301 and DS402

---

### What this chapter contains

This chapter contains a list of the CANopen error codes.

### Error codes

Error codes can be read from the objects 0x200B and 0x603F (hex). Additionally, the MN can query the status of the CN with the StatusResponse service. See chapter [Network Management Services](#).

Error codes between xx80...xFF (hex) and between FF00...FFFF (hex) are manufacturer specific. Descriptions for these error codes can be found in the appropriate drive firmware manual and/or the drive fault code parameter.

### Error codes

Error code (hex)	Meaning
0000	Error reset or no error
1000	Generic error
2000	Current
2100	Current on device input side
2110	Short circuit / earth leakage
2120	Earth leakage
2121	Earth leakage phase L1
2122	Earth leakage phase L2
2123	Earth leakage phase L3
2130	Short circuit
2131	Short circuit phases L1-L2
2132	Short circuit phases L2-L3
2133	Short circuit phases L3-L1
2200	Internal current

<b>Error code (hex)</b>	<b>Meaning</b>
2211	Internal current No. 1
2212	Internal current No. 2
2213	Overcurrent in ramp function
2214	Overcurrent in the sequence
2220	Continuous overcurrent
2221	Continuous overcurrent No. 1
2222	Continuous overcurrent No. 2
2230	Short circuit / earth leakage
2240	Earth leakage
2250	Short circuit
2300	Current on device output side
2310	Continuous overcurrent
2311	Continuous overcurrent No. 1
2312	Continuous overcurrent No. 2
2320	Short circuit / earth leakage
2330	Earth leakage
2331	Earth leakage phase U
2332	Earth leakage phase V
2333	Earth leakage phase W
2340	Short circuit
2341	Short circuit phases U-V
2342	Short circuit phases V-W
2343	Short circuit phases W-U
3000	Voltage
3100	Mains voltage
3110	Mains overvoltage
3111	Mains overvoltage phase L1
3112	Mains overvoltage phase L2
3113	Mains overvoltage phase L3
3120	Mains undervoltage
3121	Mains undervoltage phase L1

<b>Error code (hex)</b>	<b>Meaning</b>
3122	Mains undervoltage phase L2
3123	Mains undervoltage phase L3
3130	Phase failure
3131	Phase failure L1
3132	Phase failure L2
3133	Phase failure L3
3134	Phase sequence
3140	Mains frequency
3141	Mains frequency too great
3142	Mains frequency too small
3200	DC link voltage
3210	DC link overvoltage
3211	Overvoltage No. 1
3212	Overvoltage No. 2
3220	DC link undervoltage
3221	Undervoltage No. 1
3222	Undervoltage No. 2
3230	Load error
3300	Output voltage
3310	Output overvoltage
3311	Output overvoltage phase U
3312	Output overvoltage phase V
3313	Output overvoltage phase W
3320	Armature circuit
3321	Armature circuit interrupted
3330	Field circuit
3331	Field circuit interrupted
4000	Temperature
4100	Ambient temperature
4110	Excess ambient temperature
4120	Too low ambient temperature

<b>Error code (hex)</b>	<b>Meaning</b>
4130	Temperature supply air
4140	Temperature air outlet
4200	Temperature device
4210	Excess temperature device
4220	Too low temperature device
4300	Temperature drive
4310	Excess temperature drive
4320	Too low temperature drive
4400	Temperature supply
4410	Excess temperature supply
4420	Too low temperature supply
5000	Device hardware
5100	Supply
5110	Supply low voltage
5111	U1 = supply +/-15 V
5112	U2 = supply +24 V
5113	U3 = supply +5 V
5114	U4 = manufacturer specific
5115	U5 = manufacturer specific
5116	U6 = manufacturer specific
5117	U7 = manufacturer specific
5118	U8 = manufacturer specific
5119	U9 = manufacturer specific
5120	Supply intermediate circuit
5200	Control
5210	Measurement circuit
5220	Computing circuit
5300	Operating unit
5400	Power section
5410	Output stages
5420	Chopper

<b>Error code (hex)</b>	<b>Meaning</b>
5430	Input stages
5440	Contactors
5441	Contactor 1 = manufacturer specific
5442	Contactor 2 = manufacturer specific
5443	Contactor 3 = manufacturer specific
5444	Contactor 4 = manufacturer specific
5445	Contactor 5 = manufacturer specific
5450	Fuses
5451	S1 = L1
5452	S2 = L2
5453	S3 = L3
5454	S4 = manufacturer specific
5455	S5 = manufacturer specific
5456	S6 = manufacturer specific
5457	S7 = manufacturer specific
5458	S8 = manufacturer specific
5459	S9 = manufacturer specific
5500	Data storage
5510	Working memory
5520	Program memory
5530	Non-volatile data memory
6000	Device software
6010	Software reset (Watchdog)
6100	Internal software
6200	User software
6300	Data record
6301	Data record No. 1
...	from 2... 14 corresponding
630F	Data record No. 15
6310	Loss of parameters
6320	Parameter error

<b>Error code (hex)</b>	<b>Meaning</b>
6330	Ethernet POWERLINK module configuration error
7000	Additional modules
7100	Power
7110	Brake chopper
7111	Failure brake chopper
7112	Overcurrent brake chopper
7113	Protective circuit brake chopper
7120	Motor
7121	Motor blocked
7122	Motor error or communication malfunc.
7123	Motor tilted
7200	Measurement circuit
7300	Sensor
7301	Tacho fault
7302	Tacho wrong polarity
7303	Resolver 1 fault
7304	Resolver 2 fault
7305	Incremental sensor 1 fault
7306	Incremental sensor 2 fault
7307	Incremental sensor 3 fault
7310	Speed
7320	Position
7400	Computation circuit
7500	Communication
7510	Serial interface no. 1
7520	Serial interface no. 2
7600	Data storage
8000	Monitoring
8100	Communication
8300	Torque control
8311	Excess torque

<b>Error code (hex)</b>	<b>Meaning</b>
8312	Difficult start up
8313	Standstill torque
8321	Insufficient torque
8331	Torque fault
8400	Rotational speed controller
8500	Position controller
8600	Positioning controller
8611	Following error
8612	Reference limit
8700	Sync controller
8800	Winding controller
9000	External error
F000	Additional functions
F001	Deceleration
F002	Sub-synchronous run
F003	Stroke operation
F004	Control
FF00	Manufacturer specific
...	...
FFFF	Manufacturer specific



## Definitions and abbreviations

---

### *CN*

Controlled Node; A node in a POWERLINK network without the ability to manage the SCNM mechanism.

### *Device Description File*

All device-specific information is stored in the Device Description File (XDD) of each device.

### *MN*

Managing Node; A node capable of managing the SCNM mechanism in a POWERLINK network.

### *Object Dictionary*

A local storage of all communication objects recognized by the device.

### *OSI*

Open Systems Interconnection.

### *PDO*

Process Data Object; Used for transmitting time critical data, such as control commands, references and actual values.

### *PReq*

PollRequest; A frame used in the isochronous phase of the cyclic communication. With PollRequest, the MN requests the CN to send its data.

### *PRes*

PollResponse; A frame used in the isochronous phase of the cyclic communication. The CN responds with a PollResponse frame when it receives a PollRequest from the MN.

### *RO*

Denotes read-only access.

*RW*

Denotes read/write access.

*SDO*

Service Data Object; Used for transmitting non time critical data, such as parameters.

*SCNM*

Slot Communication Network Management; In a POWERLINK network, the MN allocates data transfer time for data from each node in a cyclic manner within a guaranteed cycle time. Within each cycle there are slots for Isochronous Data, and for Asynchronous Data for ad-hoc communication. The SCNM mechanism ensures that there are no collisions during physical network access in any of the networked nodes thus it provides deterministic communication via Legacy Ethernet.

## Technical data

---

### What this chapter contains

This chapter contains the technical specifications of the REPL-02 Ethernet POWERLINK Adapter module.

### REPL-02

#### Enclosure:

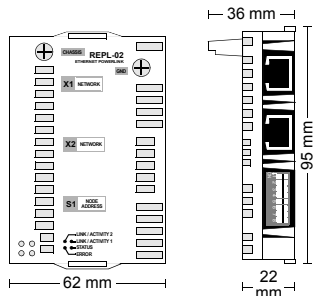

Figure 6. Enclosure of REPL-02

**Mounting:** Into an option slot on the control board of the drive.

**Degree of protection:** IP20

**Ambient conditions:** The applicable ambient conditions specified for the drive hardware manual are in effect.

#### Settings:

- Through drive parameters
- 8-way DIP switch for node address selection

**Connectors:**

- 34-pin parallel bus connector
- Two RJ-45 connectors

**Current consumption:**

- 380 mA average (5 V), supplied by the drive control board.

**General:**

- Estimated min. lifetime: 100 000 h
- All materials are UL/CSA approved.
- Complies with EMC Standards EN 50081-2 and EN 50082-2.

**Ethernet POWERLINK link**

**Compatible devices:** All Ethernet POWERLINK compliant devices

**Medium:** 100Base-TX

- Termination: Internal
- Wiring: CAT 5 UTP, CAT 5 FTP\* or CAT 5 STP\*  
(\*Recommended)

• Connector: RJ-45

• Maximum segment length: 100 m

**Serial Communication Type:** Half duplex

**Transfer Rate:** 100 Mbit/s

**Protocol:** Ethernet POWERLINK

## Appendix: IdentResponse Frame

*NMT Service Slot structure of IdentResponse*

Octet offset	Bit offset							
	7	6	5	4	3	2	1	0
0	res	res	res	res	res	res	res	res
1			PR			RS		
2	NMTStatus							
3	Reserved							
4	EPLVersion							
5	Reserved							
6...9	FeatureFlags							
10...11	MTU							
12...13	PollInSize							
14...15	PollOutSize							
16...19	ResponseTime							
20...21	Reserved							
22...25	DeviceType							
26...29	VendorID							
30...33	ProductCode							
34...37	RevisionNumber							
38...41	SerialNumber							
42...49	VendorSpecificExtension1							
50...53	VerifyConfigurationDate							
54...57	VerifyConfigurationTime							
58...61	ApplicationSwDate							
62...65	ApplicationSwTime							
66...69	IPAddress							
70...73	SubnetMask							

74...77	DefaultGateway
78...109	HostName
110...157	VendorSpecificExtension2

*NMT Service Slot data fields of IdentResponse*

Field	Abbr	Description
Priority	PR	Flags: Indicates the priority of the requested asynchronous frame (see 4.2.4.1.2.3)
RequestToSend	RS	Flags: Indicates the number of pending requests to send at the CN. The value C_DLL_MAX_RS indicates C_DLL_MAX_RS or more requests, 0 indicates no pending requests. Values: 0...C_DLL_MAX_RS
NMTStatus	stat	Reports the current status of the CN's NMT state machine.
EPLVersion	eplv	Indicates the POWERLINK version to which the CN conforms.
FeatureFlags	feat	Reports the feature flags of the device. (NMT_FeatureFlags_U32)
MTU	mtu	Reports the size of the largest IP frame that can be transmitted over the network, including the size of the transport header. Values: C_DLL_MIN_ASYNC_MTU ... C_DLL_MAX_ASYNC_MTU
PollInSize	pis	Reports the actual CN setting for PReq datablock size (NMT_CycleTiming_REC.PReqActPayloadLimit_U16).
PollOutSize	pos	Reports the actual CN setting for PReq datablock size (NMT_CycleTiming_REC.PReqActPayloadLimit_U16).
ResponseTime	rst	Reports the time required by the CN to respond to PReq. (NMT_CycleTiming_REC.PResMaxLatency_U32)
DeviceType	dt	Reports the CN's Device Type. (NMT_DeviceType_U32)
VendorID	vid	Reports the CN's Vendor ID, index. (NMT_IdentityObject_REC.Vendorid_U32)

ProductCode	prdc	Reports the CN's Product Code, index. (NMT_IdentityObject_REC.ProductCode_U32)
RevisionNumber	mo	Reports the CN's Revision Number. (NMT_IdentityObject_REC.RevisionNo_U32)
SerialNumber	sno	Reports the CN's Serial Number. (NMT_IdentityObject_REC.SerialNo_U32)
VendorSpecificExtension1	vex1	May be used for vendor specific purpose, to be filled with zeros if not in use.
VerifyConfigurationDate	vcd	Reports the CN's Configuration date (CFM_VerifyConfiguration_REC.ConfDate_U32)
VerifyConfigurationTime	vct	Reports the CN's Configuration time. (CFM_VerifyConfiguration_REC.ConfTime_U32)
ApplicationSWDate	ad	Reports the CN's Application SW date. (PDL_LocVerApplSw_REC.ApplSwDate on programmable device or date portion of NMT_ManufactSwVers_VS on non-programmable device)
ApplicationSWTime	at	Reports the CN's Application SW date. (PDL_LocVerApplSw_REC.ApplSwTime on programmable device or time portion of NMT_ManufactSwVers_VS on non-programmable device)
IPAddress	ipa	Reports the current IP address value of the CN. (NWL_IpAddrTable_Xh_REC.Addr_IPAD)
SubnetMask	snm	Reports the current IP subnet mask value of the CN. (NWL_IpAddrTable_Xh_REC.NetMask_IPAD)
DefaultGateway	gtw	Reports the current IP default gateway value of the CN. (NWL_IpAddrTable_Xh_REC.DefGateway_IPAD)
HostName	hn	Reports the current DNS host name of the CN. (NMT_HostName_VSTR)
VendorSpecificExtension2	vex2	May be used for vendor specific purpose, to be filled with zeros if not in use.







**ABB Oy**  
AC Drives  
P.O. Box 184  
FI-00381 HELSINKI  
FINLAND  
Telephone +358 10 22 11  
Fax +358 10 22 22681  
Internet [www.abb.com](http://www.abb.com)

**ABB Inc.**  
Automation Technologies  
Drives & Motors  
16250 West Glendale Drive  
New Berlin, WI 53151  
USA  
Telephone 262 785-3200  
800-HELP-365  
Fax 262 780-5135

**ABB Beijing Drive Systems Co. Ltd.**  
No. 1, Block D, A-10 Jiuxianqiao Beilu  
Chaoyang District  
Beijing, P.R. China, 100015  
Telephone +86 10 5821 7788  
Fax +86 10 5821 7618  
Internet [www.abb.com](http://www.abb.com)

3AUA000090411 REV A / EN  
EFFECTIVE: 2010-12-22