

ABB low voltage AC drives, wind converters and solar inverters

Capacitor reforming instructions

Converter modules with electrolytic DC capacitors in the DC link

Table of contents

1. Introduction

Applicability	5
ABB low voltage AC drives	5
ABB wind converters	5
ABB solar inverters	5
About capacitor reforming	6
How to check the converter age	6
Safety instructions	6
Reader	6

2. Reforming the capacitors

Method 1	7
Method 2 A	7
Method 2 B	9
Reforming time	11

Further information

Product and service inquiries	13
Product training	13
Providing feedback on ABB Drives manuals	13
Document library on the Internet	13







Introduction

Applicability

This manual applies to converter modules which have electrolytic DC capacitors in the DC link. The subsections below list the converter module types and product series in more detail for each product area. All converter module types are referred to as converter or converter module in this manual.

Note: A drive (module) is used in all connection diagrams. The connection principle is the same for the other converter module types as well, considering that the terminal markings may vary.

■ ABB low voltage AC drives

This manual applies to drive, inverter, IGBT supply and brake modules in product series ACS800, ACS850, ACQ810 and ACSM1, ie, the following module types:

- ACS800-01, -02, -04, -104 and -104LC
- ACS850-04
- ACQ850-04
- ACSM1-04 and ACSM1-204.

■ ABB wind converters

This manual applies to line-side converter modules and generator-side converter modules in product series ACS800-77LC.

Note: ACS800-67 and ACS800-77 modules include film capacitors in the DC link instead of electrolytic capacitors. The film capacitors do not need to be reformed.

■ ABB solar inverters

This manual applies to solar inverter modules in product series PVS800-57.

About capacitor reforming

Converter DC link capacitors need to be reformed (re-aged) if the converter has been non-operational for more than one year. Without reforming, capacitors may get damaged when the converter starts to operate. It is recommended to reform the capacitors once a year.

Besides the reforming methods presented in this manual, ABB can supply you with ready-made reforming devices, such as FINERO FST-DCP 1500-05 and FUG HCK 400-2000. For more information on purchasing these devices, contact your local ABB representative.

How to check the converter age

Converter serial number defines the week when the converter was manufactured:

- 7 digits: For example, in 3260034, 3 denotes manufacturing year (2003), 26 manufacturing week and 0034 running manufacturing number.
- 8 digits: For example, in 14250125, 1 denotes manufacturing country (1 = Finland), 4 manufacturing year (2004), 25 manufacturing week and 0125 running manufacturing number.
- 10 digits: For example, in 1063200725, 1 denotes manufacturing country, 06 manufacturing year (2006), 32 manufacturing week and 00725 running manufacturing number.

Safety instructions



WARNING! Neglecting the following instructions may cause physical injury or death.

- All electrical installation and maintenance work on the converter should be carried out by qualified electricians only.
- Never work on the converter, motor cable or motor when input power is applied. After disconnecting the input power, always wait for 5 minutes to let the intermediate circuit capacitors to discharge before you start working on the converter, the motor or motor cable.
- Always ensure by measuring with a multimeter (impedance at least 1 Mohm) that:
 1. voltage between converter input phases U1, V1 and W1 and the frame is close to 0 V.
 2. voltage between terminals UDC+ and UDC- and the frame is close to 0 V.
- Never switch on the converter power supply while the reforming circuit is connected. Lock the disconnecter (if any) to an open position.
- Ensure that the converter is clean and dry (no condensation) before starting the reforming.

In addition to the safety instructions given above, follow all safety instructions delivered with the converter or given later in this manual. The complete safety instructions are given at the beginning of the *Hardware manual*.

Reader

You are expected to know the standard electrical wiring practices, electronic components, and electrical schematic symbols.

2

Reforming the capacitors

Method 1

Use method 1 for capacitor reforming if the converters have been stocked (non-operational) for less than two years.

1. Switch the power on to the converter for the time indicated in section [Reforming time](#) on page [11](#).
2. Do not load the converter while the reforming is ongoing.

The converter “wakes up” its capacitors on its own, after which it is ready for use.

Method 2 A

Use method 2 A or method 2 B (page [9](#)) for capacitor reforming if the converters have been stocked (non-operational) for two years or longer.



WARNING! Never switch on the converter power supply while the reforming circuit is connected. Lock the disconnecter (if any) to an open position.



WARNING! Only a qualified electrician is allowed to do the work. Read and follow the instructions below. Neglecting the instructions may cause physical injury or death.

1. Ensure that the converter module is disconnected from all possible power sources (all AC and DC inputs/outputs are disconnected).
 2. Ensure by measuring that the converter is dead (terminals U1, V1, W1, UDC+, UDC-, U2, V2 and W2).
-

8 Reforming the capacitors

3. Compose a reforming circuit (see the diagram and data below) and connect it to the DC terminals of the converter module.
4. Switch on the reforming circuit for the time defined in section [Reforming time](#) on page 11.

Note: Limit the reforming current to max. 500 mA. If the DC power supply does not have an adjustable current limiter, increase the voltage gradually from 0 to a full scale value.

5. Switch off the reforming circuit.
6. Wait for 5 minutes to let the converter DC capacitors discharge.
7. Ensure by measuring that the DC terminals of the converter are dead.
8. Disconnect the reforming circuit from the converter.

Regulated DC power with active current limiting:

- Output current: 0.5...1 A DC, max. 500 mA during reforming
- Output voltage: adjustable 0...1000 V DC. An appropriate voltage during reforming is $1.35 U_x$. U_x denotes the nominal AC voltage of the converter.

An external resistor is not needed if the DC power supply has an adjustable current limiter.

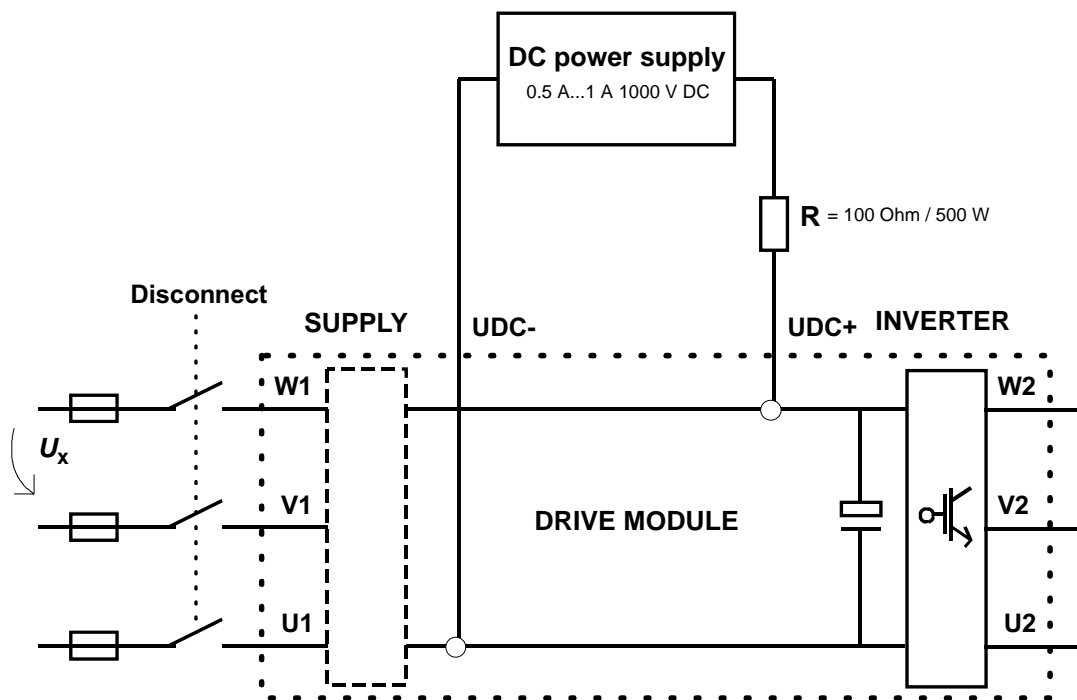

Method 2 B

Use method 2 B or method 2 A (page 7) for capacitor reforming if the converters have been stocked (non-operational) for two years or longer.



WARNING! Never switch on the converter power supply while the reforming circuit is connected. Lock the disconnecter (if any) to an open position.



WARNING! Only a qualified electrician is allowed to do the work. Read and follow the instructions below. Neglecting the instructions may cause physical injury or death.

1. Ensure that the converter module is disconnected from all possible power sources (all AC and DC inputs/outputs are disconnected).
 2. Ensure by measuring that the converter is dead (terminals (U1, V1, W1, UDC+, UDC-, U2, V2 and W2)).
 3. Compose a reforming circuit (see the diagram and table below) and connect it to the DC terminals of the converter module.
 4. Switch on the AC power supply of the reforming circuit for the time defined in section [Reforming time](#) on page 11.
 5. Switch off and disconnect the AC power supply of the reforming circuit.
 6. Wait for 5 minutes to let the converter DC capacitors discharge.
 7. Ensure by measuring that the DC terminals of the converter are dead.
 8. Disconnect the reforming circuit from the converter.
-

10 Reforming the capacitors

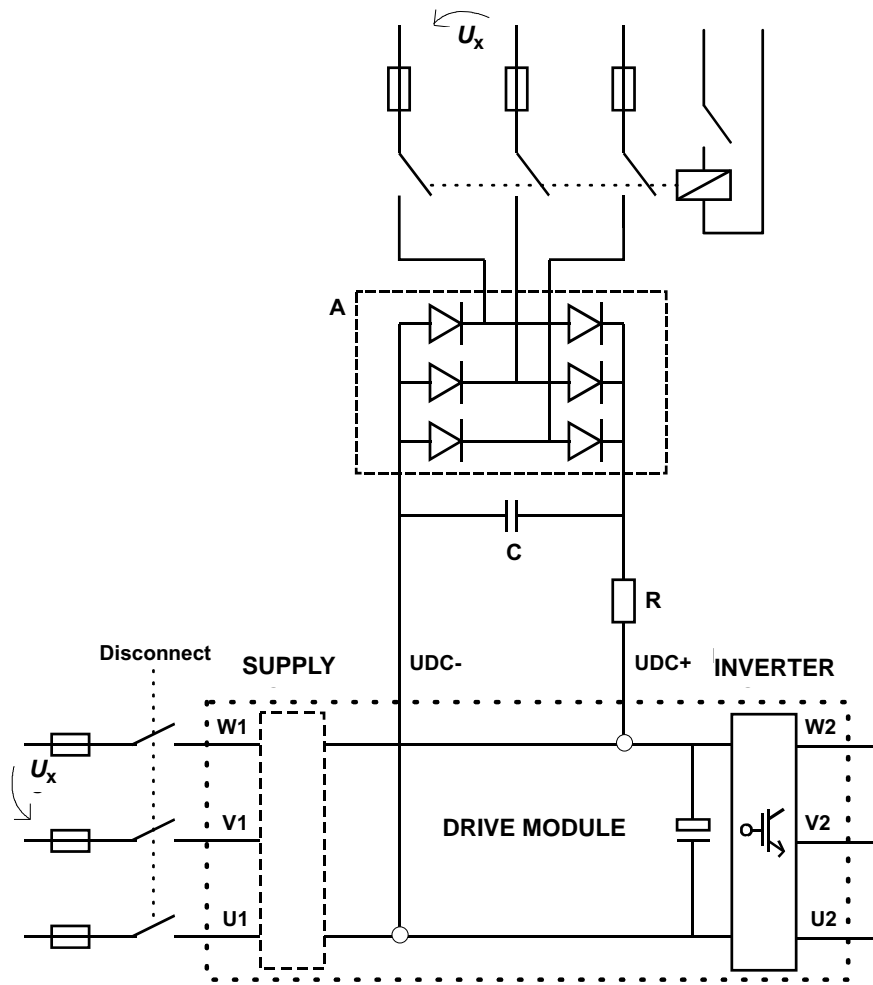

	Recommended components		
	A	R	C
$380\text{ V} < U_x < 415\text{ V}$	SKD 82/16	220 Ohm / 700 W	22 nF / 2000 V
$380\text{ V} < U_x < 500\text{ V}$	SKD 82/16	470 Ohm / 1200 W	22 nF / 2000 V
$525\text{ V} < U_x < 690\text{ V}$	SKD 82/16	680 Ohm / 1700 W	22 nF / 2000 V

Reforming time

The intermediate circuit (DC link) of the converter is connected to its nominal voltage for the reforming time to “wake up” the capacitors. The reforming time required depends on how long the converter has been stocked (non-operational), as depicted in the following diagram.

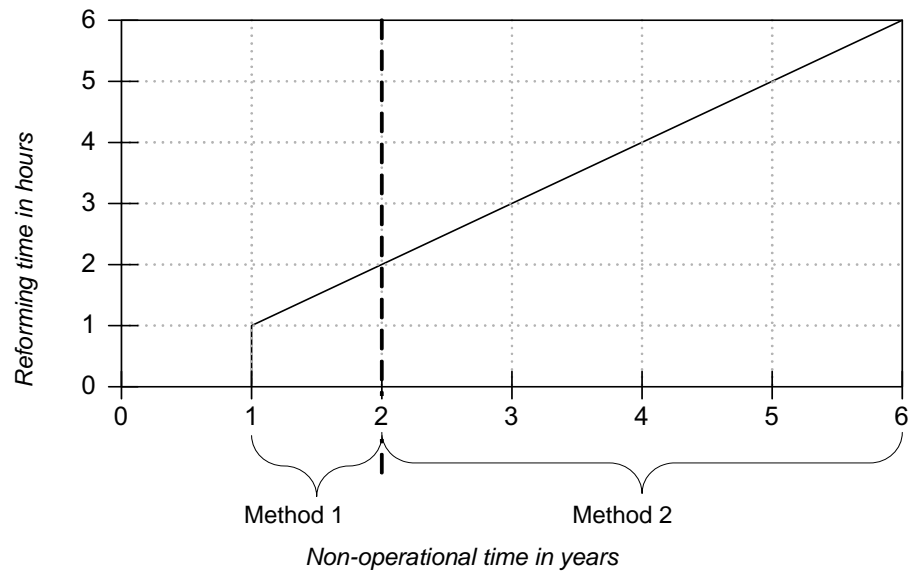

Further information

Product and service inquiries

Address any inquiries about the product to your local ABB representative, quoting the type designation and serial number of the unit in question. A listing of ABB sales, support and service contacts can be found by navigating to www.abb.com/drives and selecting *Sales, Support and Service network*.

Product training

For information on ABB product training, navigate to www.abb.com/drives and select *Training courses*.

Providing feedback on ABB Drives manuals

Your comments on our manuals are welcome. Go to www.abb.com/drives and select *Document Library – Manuals feedback form (LV AC drives)*.

Document library on the Internet

You can find manuals and other product documents in PDF format on the Internet. Go to www.abb.com/drives and select *Document Library*. You can browse the library or enter selection criteria, for example a document code, in the search field.

Contact us

ABB Oy

Drives
P.O. Box 184
FI-00381 HELSINKI
FINLAND
Telephone +358 10 22 11
Fax +358 10 22 22681
www.abb.com/drives

ABB Inc.

Automation Technologies
Drives & Motors
16250 West Glendale Drive
New Berlin, WI 53151
USA
Telephone 262 785-3200
800-HELP-365
Fax 262 780-5135
www.abb.com/drives

ABB Beijing Drive Systems Co. Ltd.

No. 1, Block D, A-10 Jiuxianqiao Beilu
Chaoyang District
Beijing, P.R. China, 100015
Telephone +86 10 5821 7788
Fax +86 10 5821 7618
www.abb.com/drives

3BFE64059629 Rev D EN 2009-12-14