

No. ADD49/96
Contract No. V/78444

Date 2.9.97

Product 4670 Turbidity Monitoring Systems
Manual IM/4670 Issue 6

High Level Turbidity Flow Monitoring System (2300DF Sensor)

1 Introduction

The information in this addendum is supplementary to that contained in issue 6 of IM/4670 and covers the installation and calibration of the system with a model 2300DF sensor. Refer to the manual for all programming procedures.

2 Dimensions and Location

Fig. 1 shows the overall dimensions of this turbidity monitoring unit. A typical configuration is shown in Fig. 2.



Important Note. For optimum accuracy ensure that the sample flow through the system is VERTICALLY UPWARDS.

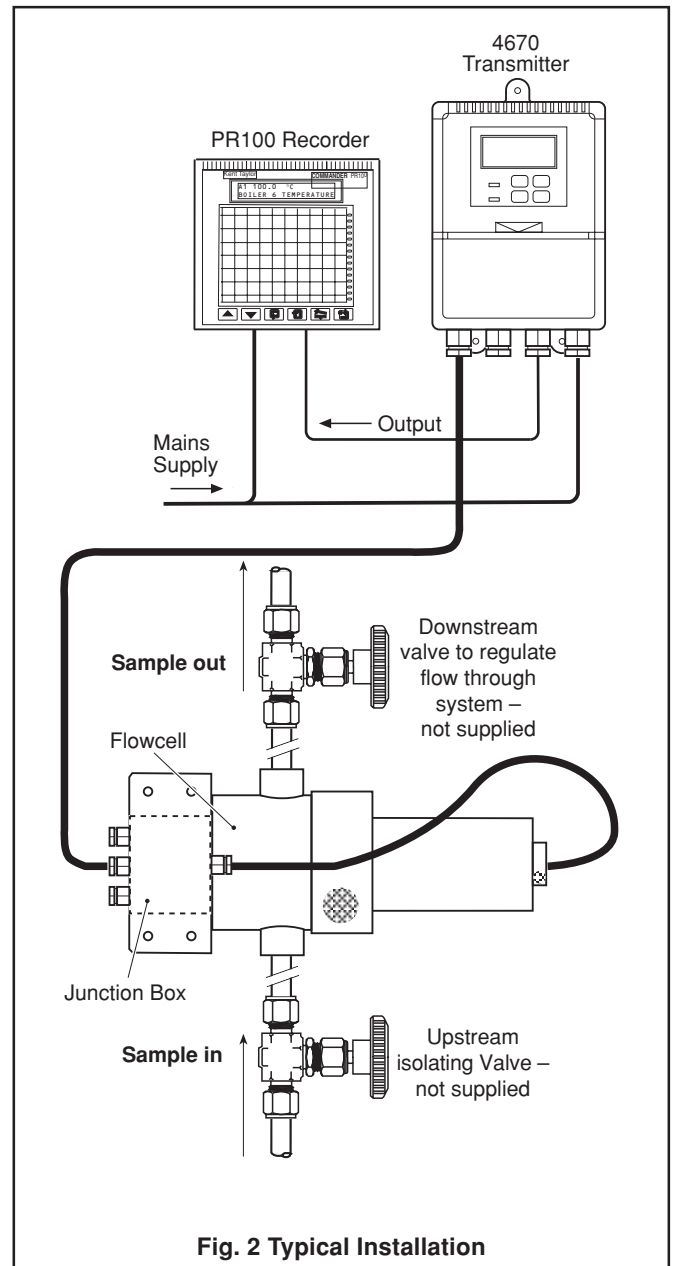
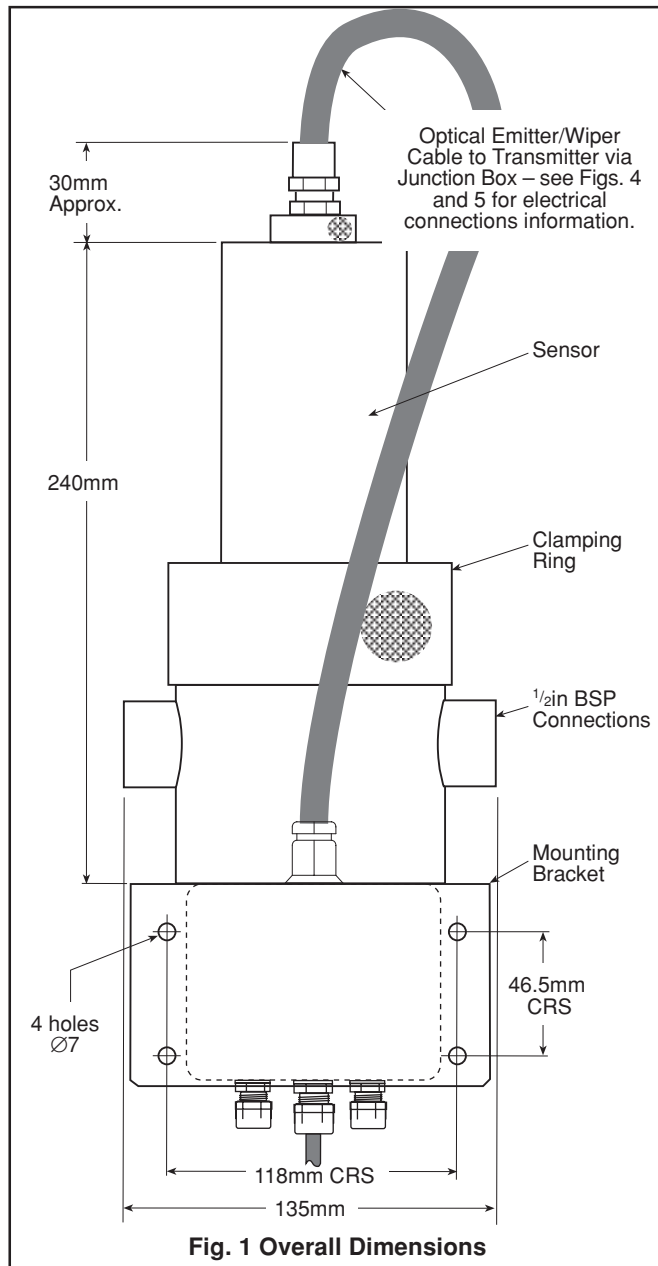

3 Calibration Procedure (Fig. 2 and Fig. 3)

- a) Isolate the system by closing the flow regulating valves upstream and downstream of the flowcell – see Fig. 2.

Caution. Because the sensor and flow chamber are designed to be a close fit, care must be taken not to damage the equipment during withdrawal of the sensor.

- b) Unscrew the clamping ring and remove the sensor from the flow chamber – see Fig. 3. Hint: Rock the sensor up and down whilst pulling it free of the flowcell.
- c) Calibrate the sensor either using the formazine method given in the manual (Section 5.2.2), or for high turbidity solutions, the method given in Section 4 of this addendum.

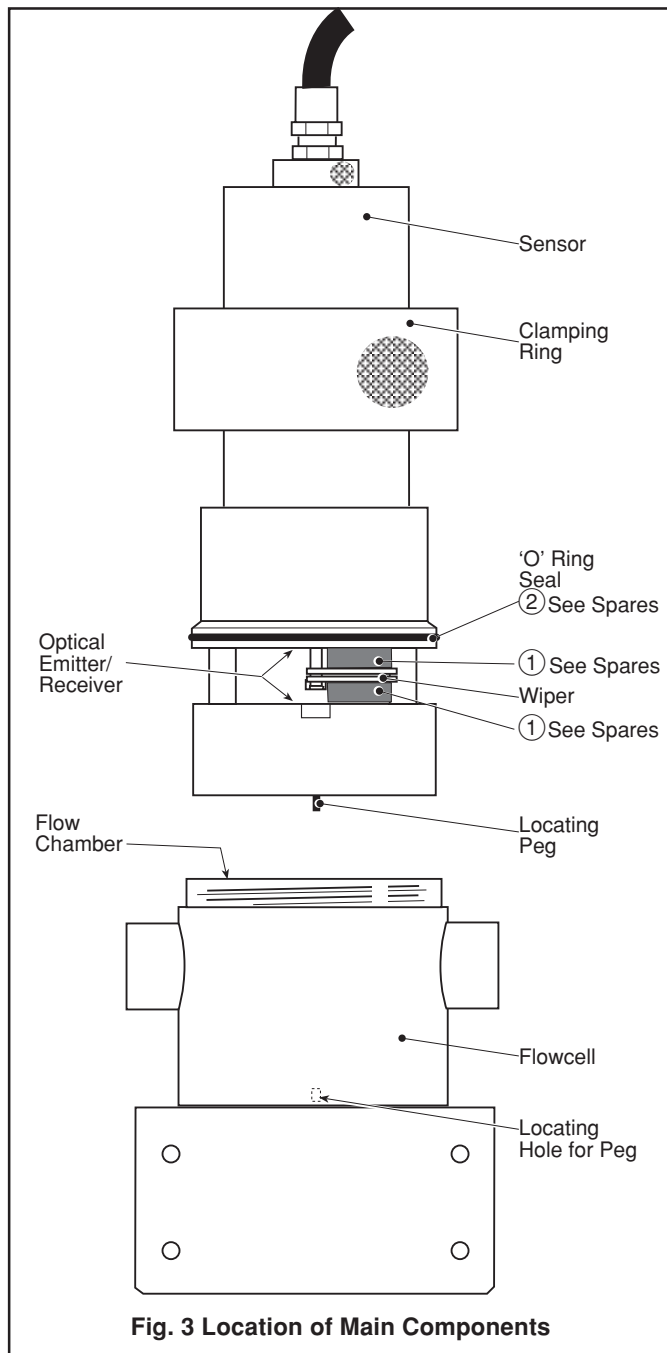

Fig. 3 Location of Main Components

- d) Wash off residual calibration solution using demineralised water.

- e) Fit the sensor into the flow chamber.

Caution. Before tightening the clamping ring, ensure that the locating peg on the sensor is engaged in the hole in the base of flow chamber – see Fig. 3. Do this by rotating the sensor in the flow chamber slowly whilst applying a downward pressure to it. When the peg locates the sensor will slide into the flowcell a further 2 or 3mm. Location is confirmed when the sensor cannot be rotated in the chamber.

- f) Tighten the clamping ring firmly – see Fig. 3.

- g) Open fully the isolating valve upstream of the flowcell and adjust the flow regulating valve downstream of the flowcell to achieve the correct flowrate – see Fig. 2 and **Specification**.

4 Preparation of Solutions

4.1 Stock Formazine ($C_2H_4N_2$) Solution

Warning. Hydrazine sulphate is toxic and may cause cancer. It may cause sensitisation of the skin.

- a) Dissolve 50.0g of hexamethylenetetramine ($C_6H_{12}N_4$) in demineralised water and dilute to 400ml (Solution A).
- b) Dissolve 5.0g of hydrazine sulphate ($N_2H_6SO_4$) in demineralised water and dilute to 400ml (Solution B).
- c) Pour solutions A and B into a one-litre volumetric flask and dilute to one litre using demineralised water.

Mix well and leave in the dark for 24 hours at $25^\circ C \pm 3^\circ C$.

i Information.

- The turbidity of this stock solution in formazine turbidity units (FTU) is 4000.
- This solution is stable for one year if stored in the dark at a temperature of $25^\circ C \pm 3^\circ C$.

4.2 Standard solutions

Dilute the stock solution of 4000FTUs using pipettes and volumetric flasks to obtain standard solutions of turbidities in the range of interest.

*** Note.**

- Standard solutions are only stable for one week and should be stored in the dark.
- Fresh solutions should be made up each time the wet calibration procedure is carried out, and discarded after use in accordance with local regulations.

5 Cable Replacement (Figs. 4 and 5)



Information. If a longer cable between the 4670 500 transmitter unit and the junction box is to be fitted, remove the existing cable and replace it making the appropriate connections shown in Fig. 4 and Fig. 5.

6 Spares (see Fig. 3)

Item	Description	Part No.
1	Wiper blade – 2 off	7997 133
2	'O' ring	BS 200-151-4470

7 Specification (2300DF)

Range: 0 to 2000FTU, programmable.
 Process connections: 1/2in BSP.
 Principle: Transmitted light.
 Characteristics: Logarithmic based on formazine.
 Resolution: 1FTU.
 Flowrate: 1 to 2 lmin⁻¹
 Calibrated accuracy: ±10% of reading or 10FTU, whichever is the greater.
 Temperature drift: 0.2FTU°C⁻¹
 Sample temperature: 0°C to 50°C
 Integral wiping system: .. Programmable operating frequency every 0.25h, 0.5h, 0.75h, or in multiples of 1h up to 24h.

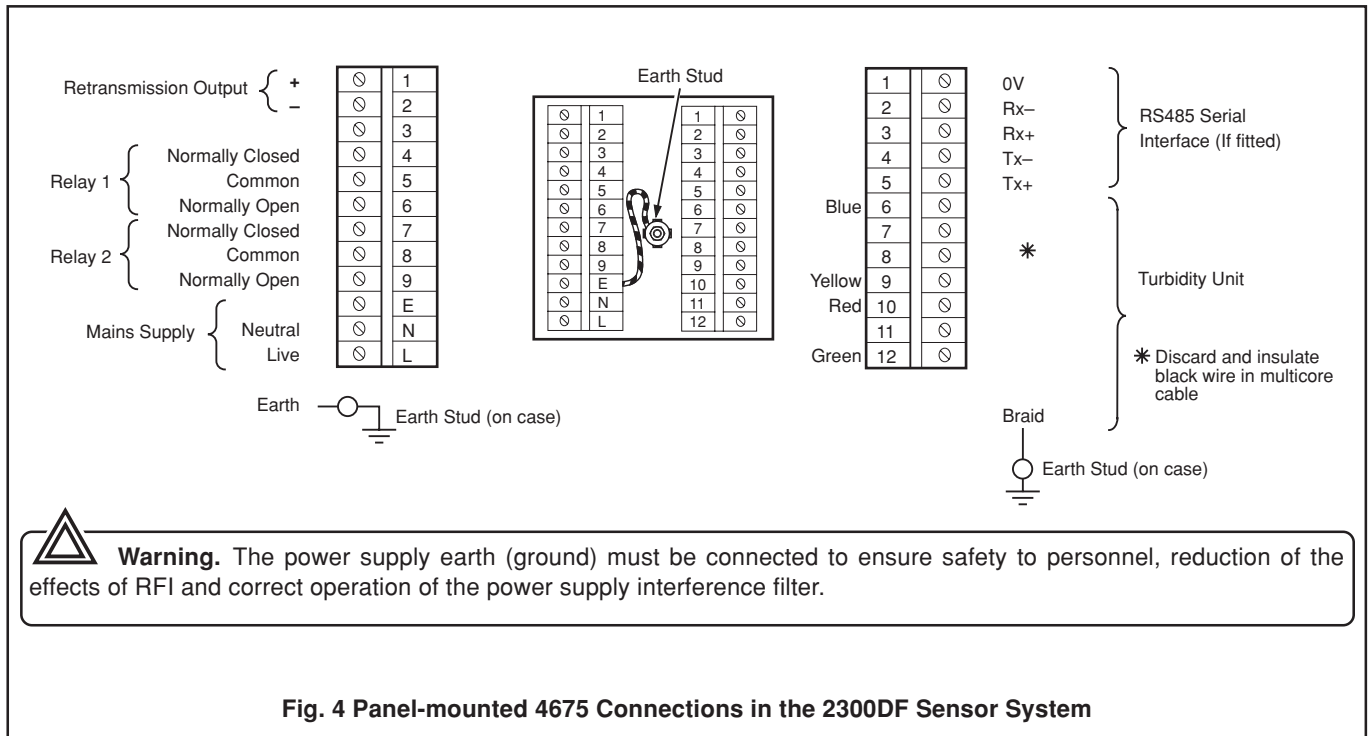

Fig. 4 Panel-mounted 4675 Connections in the 2300DF Sensor System

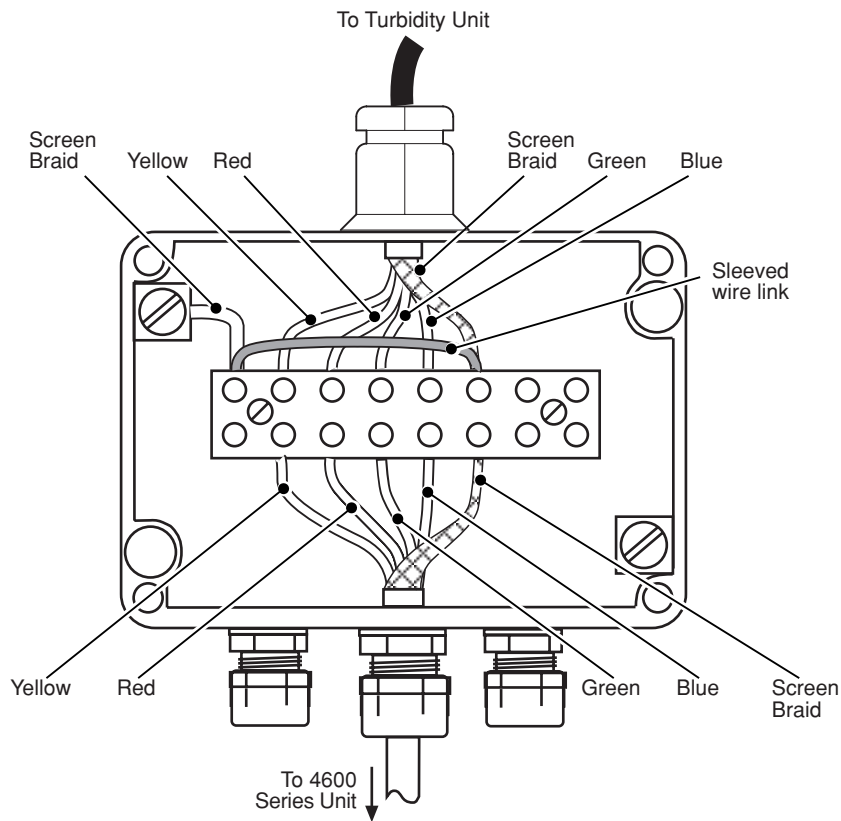

Fig. 5 Turbidity Unit Connection Box in the 2300DF Sensor System

ABB has Sales & Customer Support expertise in over 100 countries worldwide

www.abb.com

The Company's policy is one of continuous product improvement and the right is reserved to modify the information contained herein without notice.

Printed in UK (03.04)

© ABB 2004



ABB Limited
 Oldends Lane, Stonehouse
 Gloucestershire, GL10 3TA
 UK
 Tel: +44 (0)1453 826661
 Fax: +44 (0)1453 829671

ABB Inc.
 2175 Lockheed Way
 Carson City, NV 89706
 USA
 Tel: +1 (0) 775 883 4366
 Fax: +1 (0) 775 883 4373