

- **High visibility 5-digit LED display**
 - clear and accurate indication
- **Analog and relay outputs as standard**
 - high, low, latch and rate alarms, plus isolated retransmission
- **Maths functions included as standard**
 - SG correction, tank volume calculation plus a 20-point linearizer
- **Max./Min. and Average levels**
 - as standard the L150 can store these values
- **IP65 (NEMA 3) front facia protection**
 - designed for use in damp environments
- **Submersible level and pressure sensors with failure alarms**
 - a logic output indicates sensor failure
- **RS485/Modbus serial communications**
 - SCADA, PLC and open system integration

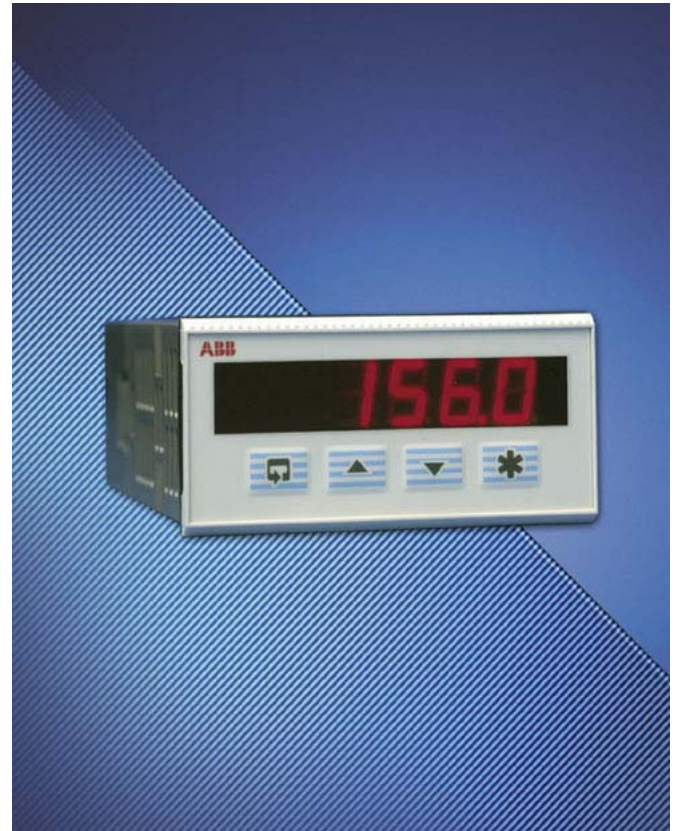

L150
– the flexible level system that
meets your needs

L150

The L150 1/8 DIN panel-mount Level Indicator is a highly versatile unit, accepting inputs from a wide range of level sensors offered by ABB and third party suppliers.

As standard the L150 has a 5-digit indicator with an IP65 front fascia. It includes an alarm relay, 4 to 20mA retransmission, logic output and selectable maths function which can make corrections for SG or calculate tank volume.

A 20-point linearizer is also included for volumes in horizontal or dished-end tanks. There is also a feature to store the max./min./average values.

Up to two additional relays, a logic output or RS485 Modbus serial communication are available as optional extras.



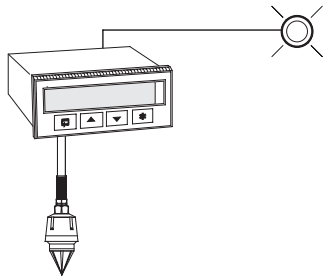

Display and Alarm

The L150's built-in 5A relays can be used to annunciate high level, low level or rate alarms. Active alarms are indicated by flashing LED's to the right of the main display.

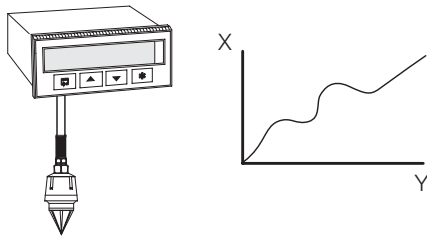

Custom Linearization

As standard the L150 has a 20-breakpoint linearizer suitable for volume calculation. (Factory setup using PC configurator).

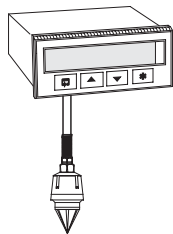

Average/Maximum/Minimum

As standard the L150 includes the ability to retain the average, highest and lowest level values. This is a particularly useful feature for unmanned sites, allowing a visiting operator to check quickly for abnormal levels.

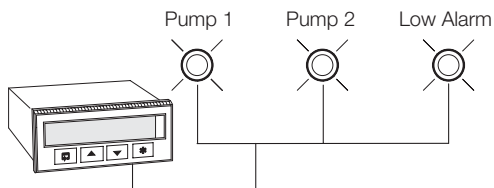

Pump Control

Using the programmable hysteresis on the built-in relay makes the L150 ideal for simple single-pump control. With optional relays fitted, a multiple-pump control system can be configured.

Specification

Operation

Display

High-intensity 7-segment, 1 x 5-digit LED display	
Three alarm LED indicators	
Display range	-9999 to +99999
Display resolution	±1 digit
Display height	14mm (0.56 in.)

Configuration

User-defined via front panel or PC configurator

Standard Functions

Alarms

Number	Three user-defined
Types	High/Low process High/Low latch Fast/Slow rate

Alarm hysteresis

0 to 100% of range

Math functions

Maximum and minimum value detection
Average level
SG correction
Tank volume calculation
20-breakpoint custom linearizer (factory configured)

Analog Input

Input type

1 to 10 mA, 4 to 20 mA or customize via PC Configurator

Input sampling rate

250ms

Accuracy

Indicator	0.2% of reading
Output	<0.2% of span

Sensor power supply

24V, 30mA max. (powers one 2-wire transmitter)
± 3V, 15mA (power for P851/P861 sensors)*
*Option board

Outputs – Standard Build

Retransmission

Analog, configurable in the range 4 to 20mA	
Max. load	15V (750Ω at 20mA)
Isolation	500V DC from sensor input (not isolated from logic output)

Logic output

18V DC at 20mA	
Min. load	400Ω
Isolation	500V from sensor input (not isolated from retransmission output)

Relay output

One relay as standard (SPDT) 5A at 115/230V AC, 5A at 24V DC, assignable to alarms

Option

One option board can be installed from:

Type 00	One relay + retransmission + logic output (Standard Build)
Type 01	Two relays + retransmission + logic output
Type 02	Three relays + retransmission + logic output + digital input
Type 03	Two relays + retransmission + logic output + digital input + RS485/Modbus
Type 04	Two relays + retransmission + logic output + P851/P861 power supply

I/O

Relay output

SPDT 5A at 115/230V AC
Assignable to alarms

Digital input

Type	Volt-free
Minimum pulse	250ms

Modbus serial communications

Connections RS422/RS485, 2- or 4-wire
Speed 2.4k or 9.6k baud rate
Protocol Modbus RTU slave

Electrical

Voltage (supply)

85 to 265V AC 50/60Hz
24V DC optional

Power consumption

< 6VA (85 to 265V AC)
< 5W (24V DC)

Power interruption protection

<60ms/<3 cycles, no effect
>60ms/>3 cycles, instrument returns to operation after a controlled reset

Physical

Size

96mm wide x 48mm high x 125mm
(3.78 in. wide x 1.89 in. high x 4.92 in.)

Weight

250g (0.5lb) approximate

Environmental

Operating limits

-10 to 55°C (14 to 131°F)
5 to 95% RH non-condensing

Temperature stability

<0.02% of reading or 2μV/°C (1μV/°F)

Front face

IP65 (NEMA 3), case rear IP20

EMC

Emissions

Meets requirements of EN50081-2

Immunity

Meets requirements of EN50082-2

Design and manufacturing standards

CE mark

Electrical safety

IEC 348

Overall Dimensions

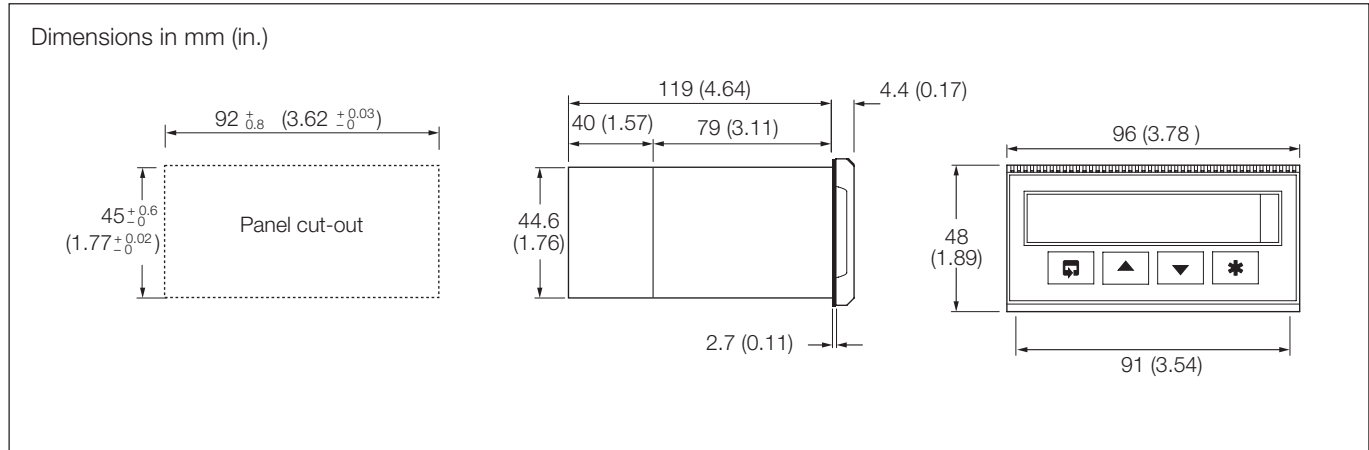

Electrical Connections

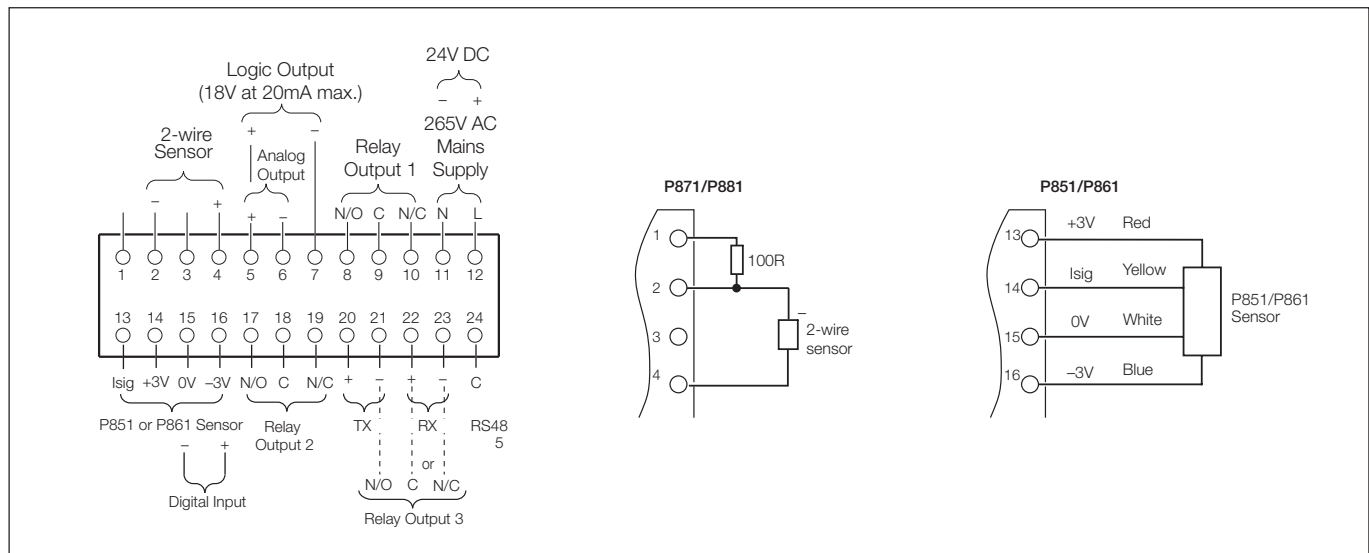

Ordering Information

L150 1/8 DIN Level Indicator	L150 /	X	X	X	X	/	X	X	X	X
Options										
1 relay + retransmission + logic output		0	0							
2 relays + retransmission + logic output		0	1							
3 relays + retransmission + logic output + digital input		0	2							
2 relays + retransmission + logic output + digital input + Modbus		0	3							
2 relays + retransmission + logic output + P851/P861 power supply		0	4							
Power supply										
85V to 265V AC									0	
24V DC									1	
Build										
ABB Standard										0
Programming/Special Features										
Configured to factory standard										S T D
Configured to customer requirements										C U S X
Special features										S P X

Accessories

PC Configuration Kit (part no. C100/0700)

Licensing, Trademarks and Copyrights

Modbus™ is a trademark of Modicon, Inc.

Windows™ is a trademark of the Microsoft Corp.

ABB has Sales & Customer Support expertise in over 100 countries worldwide

www.abb.com

The Company's policy is one of continuous product improvement and the right is reserved to modify the information contained herein without notice.

Printed in UK (08.07)

© ABB 2007



ABB Limited

Howard Road, St Neots
Cambridgeshire
PE19 8EU
UK
Tel: +44 (0)1480 475321
Fax: +44 (0)1480 217948

ABB Inc.

125 E. County Line Road
Warminster
PA 18974
USA
Tel: +1 215 674 6000
Fax: +1 215 674 7183