

- **Monitors both low and high dissolved oxygen concentrations**
  - making it suitable for measurement during two-shifting and baseload operations on power stations
- **Customer programmable range**
  - enables optimum range to be selected to suit chemistry regime
- **Fast response**
  - reacts to rapid changes in plant conditions
- **Automatic calibration**
  - minimizes manual intervention and protects sensor during calibration
- **Thermal protection**
  - protects sensor in the event of cooling water failure
- **Disposable sensor**
  - minimizes down time and avoids the need for skilled personnel to carry out sensor refurbishment
- **Comprehensive diagnostics**
  - provides sensor condition and instrument status data



An automatic low and high level dissolved oxygen monitor providing maximum information for minimal manual intervention

## Introduction

The high costs involved in replacing damaged equipment, coupled with the need to extend the periods between plant overhauls, has resulted in increased importance being placed on preventative maintenance. This principle has been extended to maintaining the quality of feed water running through the process system in order to reduce corrosion damage to boilers and related equipment.

One of the major forms of boiler damage is oxidative corrosion. This occurs when oxygen dissolved in the process water comes into contact with the metal surfaces inside the boiler. During these conditions electrolytic action establishes a potential difference between the oxygen and metal which, if allowed to continue, causes severe pitting and the eventual failure of the metal components.

Some plants, particularly those with once-through boilers, are often operated using chemistry regimes which involve the dosing of oxygen into the boiler feed water to encourage the formation of the smooth haematite. This reduces the pressure drop in the plant resulting in increased plant efficiency.

Whether the need is: to control the oxygen to very low levels; to encourage the formation of a protective layer of magnetite and minimize corrosion damage; or to dose oxygen and maintain the concentration between certain limits, it is necessary to pay close attention to oxygen levels and to enable remedial action to be taken to ensure that the oxygen concentration is kept within the plant operating specification. As the oxygen levels tend to vary considerably during the load cycle of a plant and different chemistry regimes call for different oxygen levels to be maintained, an analyzer is required that can cope with both high and low levels of dissolved oxygen. It should also be capable of responding rapidly to changes in dissolved oxygen concentration and allow the customer to program the range to suit the duty and do this with the minimum amount of manual intervention.

## General Information

The ABB 9438 Dissolved Oxygen Monitor uses a galvanic-type sensor to accurately measure the levels of dissolved oxygen in the process feed water. It has been designed specifically for online use in power generation and related process plant.

The 9438 is an accurate, automatic, reliable instrument that requires no maintenance and can be customer-programmed to monitor dissolved oxygen between the ranges 0 to 20  $\mu\text{g}/\text{kg}$  and 0 to 20  $\text{mg}/\text{kg}$ .

The 9438 comprises a transmitter, a liquid-handling system with environmental enclosure and a 24 V DC power supply unit for the calibration solenoid valve.

Optional items include:

- Serial data interface
- Second current output

The power supply unit for the calibration solenoid valve is capable of driving the valves of up to four monitors. Customers installing up to this number of monitors in close proximity need order only one monitor which includes a valve power supply unit and the remaining monitors can be ordered without the valve power supply unit.

Some customers may already have a 24 V DC supply available and, in such cases, require only the version without the 24V power supply unit.

The transmitter can be mounted adjacent to the liquid-handling panel or up to 30 m (100 ft) apart. Interconnecting cables are available in lengths of 1.0, 5.0, 10 and 30 m (3, 15, 30 and 100 ft).

### The 9438 Series Transmitter

The 9438 Series transmitter provides the operator interface and communications to other devices. The signals from the oxygen and temperature sensors are converted by the transmitter and information is presented on a large, custom-designed, backlit, liquid crystal display (LCD) as a  $\mu\text{g}/\text{kg}$  or  $\text{mg}/\text{kg}$  value. The lower part of the display incorporates a 16-character alphanumeric section, which provides a variety of data including diagnostics and a 'sensor condition' bar graph. The easily-read display is used in conjunction with four tactile membrane key pads to prompt the user through the programming procedures. Included as standard is a four-language software package, displaying information in English, French, German or Spanish.

An automatic calibration facility is provided which opens the solenoid valve on the liquid-handling panel at the appropriate time. The solenoid valve is also activated to divert the sample from the sensor and hence protect it if the sample temperature exceeds  $55\text{ }^{\circ}\text{C}$  ( $131\text{ }^{\circ}\text{F}$ ).

The transmitter is equipped with two relays, the first is permanently assigned to the calibration solenoid valve and the second can be configured as:

- Concentration alarm
- Diagnostics alarm
- Auto range change switch

The basic transmitter has one analog current output, with options of a second current output or a serial data interface RS485 Modbus compatible. The current outputs can be ranged separately from the display, and from each other, and have adjustable FSD with a minimum range of 0 to  $20\text{ }\mu\text{g}/\text{kg}$  up to 0 to  $20\text{ mg}/\text{kg}$ . The two current outputs, when used in conjunction with the second alarm relay, can provide auto-range changing. The output signals can be customer configured in log, bilinear or linear formats. The main current output is also customer-selectable to provide indication of instrument status/diagnostics by stepping up the indicated value for a period of time, to a value chosen by the customer.

### Liquid-Handling Panel

The liquid-handling panel utilizes the well proven 9435-300, disposable, capsular sensor in a custom-designed flow cell. Also included on the panel is a flow regulating valve, temperature sensor, flow indicator and solenoid calibration/drain valve.

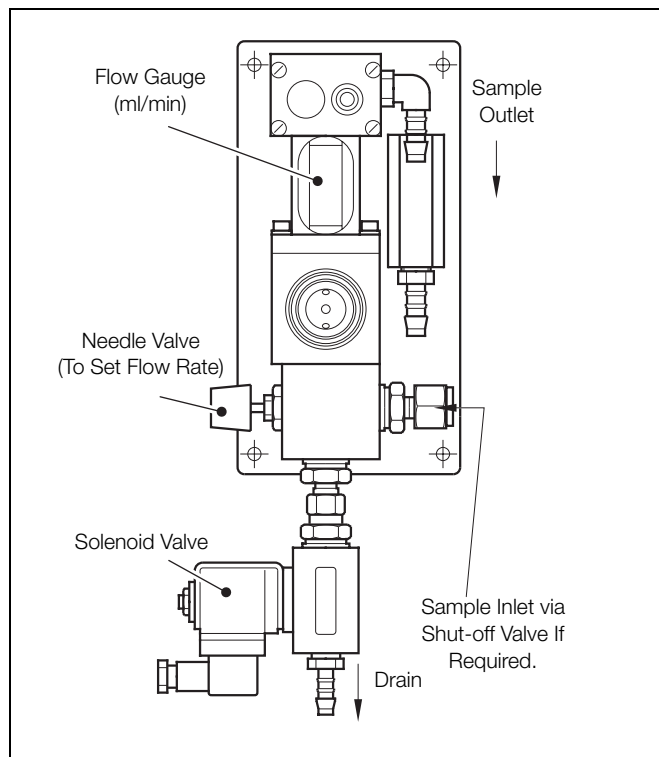

*Liquid Handling Panel Components*

### Liquid-Handling Enclosure

For additional protection and security the liquid-handling panel is in an environmental enclosure.

## Sample Flows

During calibration, or if the sample temperature exceeds 55 °C (131 °F), the solenoid valve is opened to divert the sample from the sensor to drain.

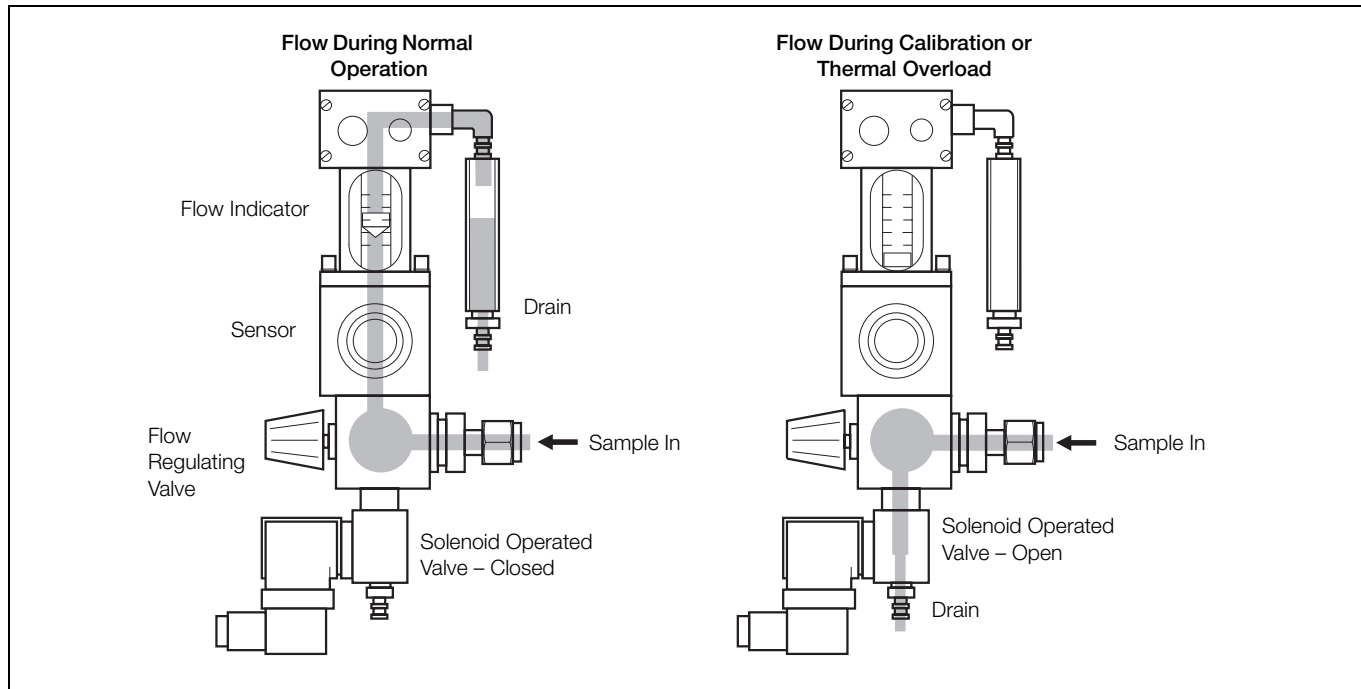

Sample Flow Paths

## Solenoid Valve Power Supply Unit

Customers installing up to four monitors in close proximity require only one monitor with power supply unit fitted and the remainder without.

Some customers may already have a 24 V DC supply available and in such cases require only the version without the 24V power supply unit.

The cable from the power supply unit to the 9438 Transmitter/Solenoid Valve is not supplied by ABB.

## Dissolved Oxygen Sensor

The sensor is a disposable galvanic cell comprising a lead anode and a silver cathode in an alkaline electrolyte. The cell reactions are:

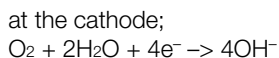
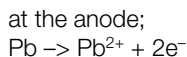

When exhausted, the capsular sensor can be quickly and easily replaced. Sensor life is dependent on process conditions.



The 9435-300 Disposable Sensor

## Specification – System

### Measuring ranges

#### Electrodes

Programmable within the ranges 0 to 20.0 µg/kg and 0 to 20 mg/kg

#### Scaling

µg/kg, mg/kg or ppb, ppm

#### Accuracy

±5 % of reading or ±1 µg/kg, whichever is the greater

#### Response time

90 % of a step change in 1 minute

#### Resolution

0.1 µg/kg

#### Stability

±5 % of reading or ±1 µg/kg per week, whichever is the greater

Not applicable when autocalibration is in operation

#### Temperature compensation

5 to 55 °C (41 to 131 °F) automatic using Pt1000 resistance thermometer

#### Salinity correction

Preset within the range 0 to 80 PPT

#### Barometric pressure correction

Preset within the range 500 to 800 mm Hg

#### Sample flow

100 to 400 ml/min

#### Sample pressure

Maximum 2 bar

#### Sample temperature

5 to 55 °C (41 to 131 °F)

#### Sensor ambient temperature

0 to 55 °C (32 to 131 °F)

#### Autocalibration frequency

1, 7 or 28 days

### Environmental Data

#### Operating temperature limits

–20 to 55 °C (–4 to 131 °F)

#### Operating humidity limits

Up to 95 % RH non-condensing

#### Storage temperature limits

Liquid-handling panel –25 to 70 °C (–13 to 158 °F)

Sensor 0 to 55 °C (32 to 131 °F)

Transmitter –25 to 70 °C (–13 to 158 °F)

Solenoid valve power supply –25 to 70 °C (–13 to 158 °F)

---

### Protection

#### Liquid handling panel

IP65

IP54 Liquid-handling panel enclosure

#### Transmitter

Panel-mount IP66/NEMA4X

Wall-mount IP66/NEMA4X front

Solenoid valve power supply IP65

---

### Power requirements

#### System

Power consumption <21 VA

#### Transmitter

Power supply 100 to 130 V or 200 to 260 V, 50/60 Hz

Power consumption <10 VA

#### Insulation, mains to earth

2kV RMS

#### Solenoid valve

Power supply 90 to 132 V or 180 to 264 V, 47/63 Hz

Power consumption <11 VA

**Mechanical Data**

**Mounting**

Transmitter	Wall or panel
Liquid-handling panel/enclosure	Wall
Solenoid valve power supply	Wall

**Overall Dimensions**

Liquid handling panel	
With environmental enclosure	250 x 440 x 160 mm (9.84 x 17.32 x 6.3 in)
Without unions and without environmental enclosure	100 approx. x 310 x 118 mm (3.94 approx. x 12.2 x 4.65 in)

**Transmitter**

Wall-mount	160 x 214 x 68 mm (6.29 x 8.43 x 2.68 in)
Panel-mount	96 x 96 x 191 mm (3.78 x 3.78 x 7.52 in)
Panel cut-out	92 x 92 mm (3.62 x 3.62 in)
Solenoid valve power supply	92 x 92 mm (3.62 x 3.62 in)

**Weights**

Liquid handling panel	
With sensor fitted and with environmental enclosure	3.9 kg (8.6 lb)
With sensor fitted, without environmental enclosure	1.3 kg (2.87 lb)
Transmitter	
Wall-mount	2 kg (4.41 lb)
Panel-mount	1.5 kg (3.31 lb)
Solenoid valve power supply	0.7 kg (1.54 lb)

**Sample connections**

Compression fitting to accept either 6 mm OD tubing or 1/4 in OD tubing – to be specified when ordering

## Specification – Transmitter

### Transmitter Display

#### Measured value

5-digit x 7-segment back-lit LCD

#### Information

16-character, single line, dot matrix, back-lit LCD

#### Insulation, contacts to earth

2 kV RMS

---

### Set Point and Relay

#### No. of set points

One

#### Set point adjustment

Programmable as a concentration or diagnostics alarm

#### Set point hysteresis

±1 % of FSD (fixed) Sensor      0 to 55 °C (32 to 131 °F)

#### Local set point annunciation

Red LED

#### No. of relays

Two – one permanently assigned to the calibration solenoid valve

#### Relay contacts

Single pole changeover

Rating:	250 V AC	250 V DC max.
	3 A AC	3 A DC max.

Loading:	750 VA	30 W max. (non-inductive)
	75 VA	3 W max. (inductive)

### Retransmission

#### No. of retransmission signals

One, fully isolated current output

0 to 10, 0 to 20 or 4 to 20 mA programmable

#### Optional second current output

0 to 10, 0 to 20 or 4 to 20 mA programmable

#### Maximum load resistance

500 Ω (20 mA maximum)

#### Serial communication

RS422/RS485 (optional, with one current output signal)

---

## Specification – Solenoid Valve PSU

**Note.** Cable from the PSU to the valve is not supplied by ABB

### Typical cable specification

3-core round      0.5 mm<sup>2</sup>

Min. current rating      3 A

Construction      16/0.2 mm

Nom. diameter      5.5 to 8.5 mm

### Voltage requirements

90 to 132 V AC or

180 to 264 V AC, 47 to 63 Hz

### Power consumption

<60 VA max.

### Output power

24 V @ 2.5 A, 60 W max. from all outputs

### Holdup time

6 ms at full load 115/230 V AC

### Line regulation

0.3 % over operating range

### Load regulation

0.5 % from min. load to full load

## Electrical Connections

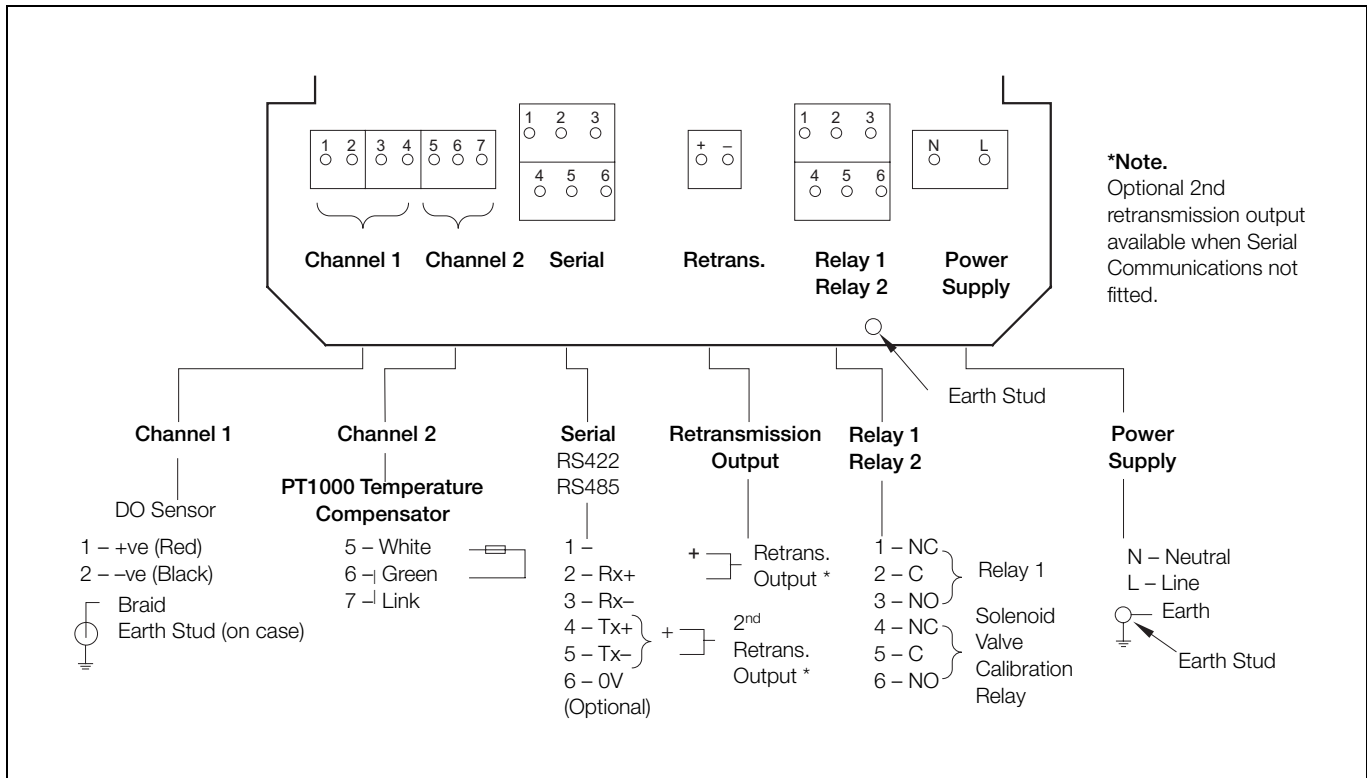

Wall-mount Transmitter

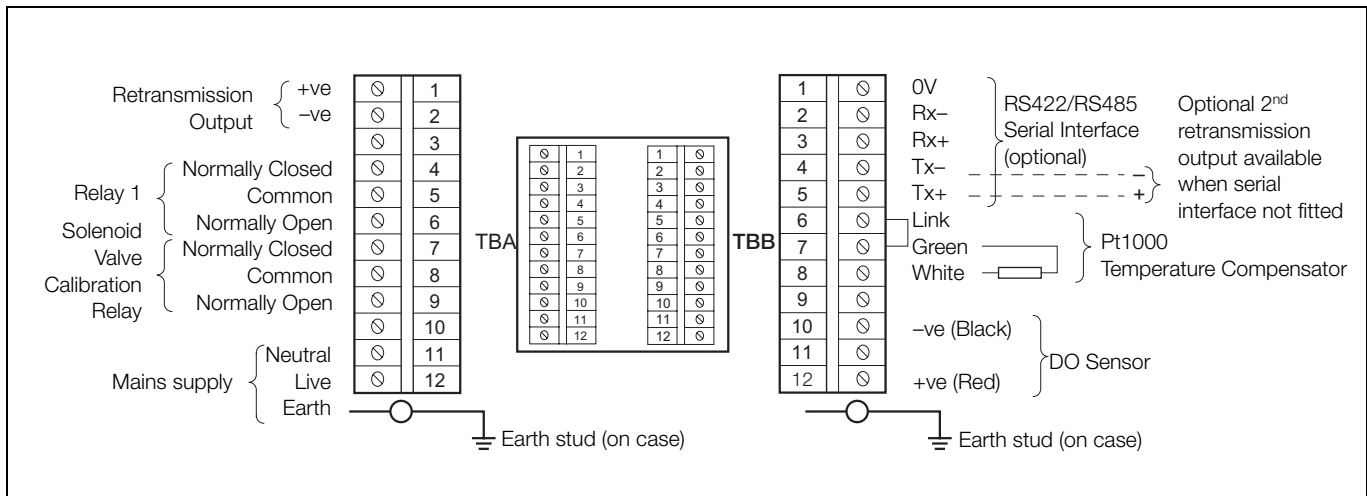

Panel-mount Transmitter

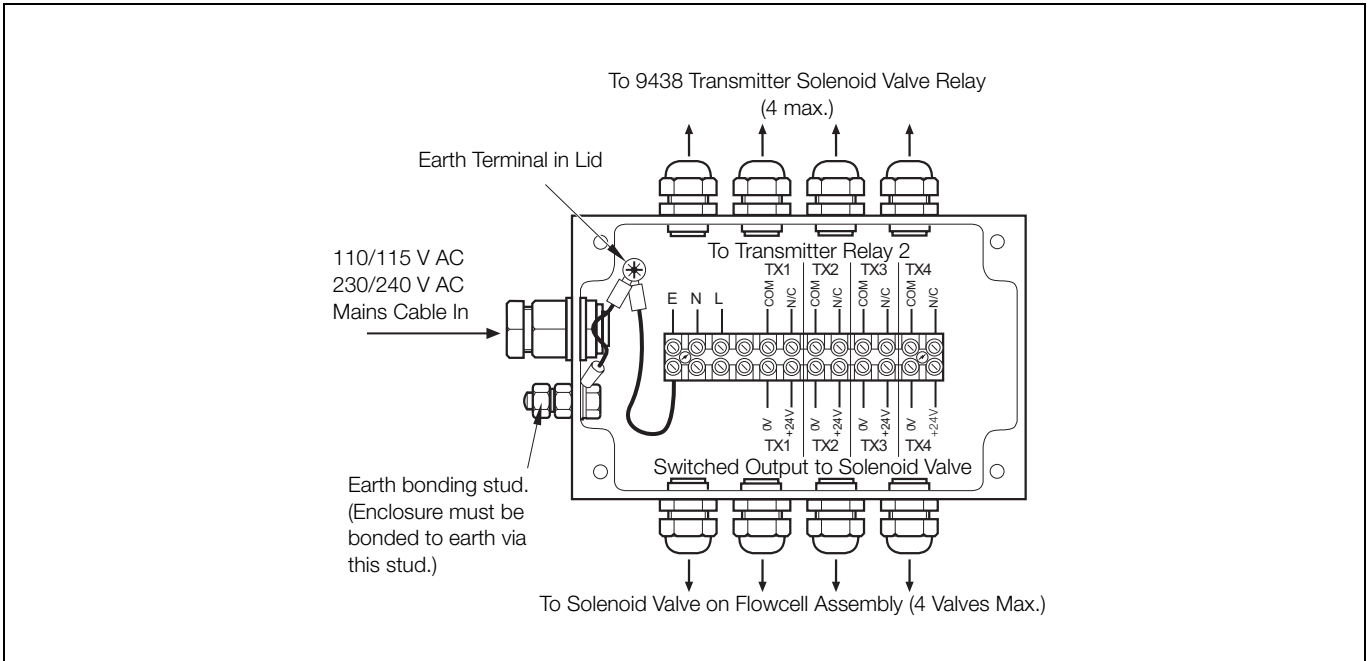

Solenoid Valve Power Supply Unit

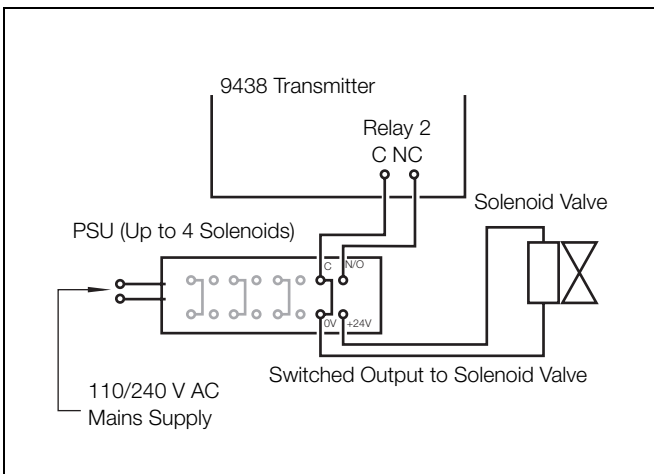

Solenoid Valve Powered via PSU

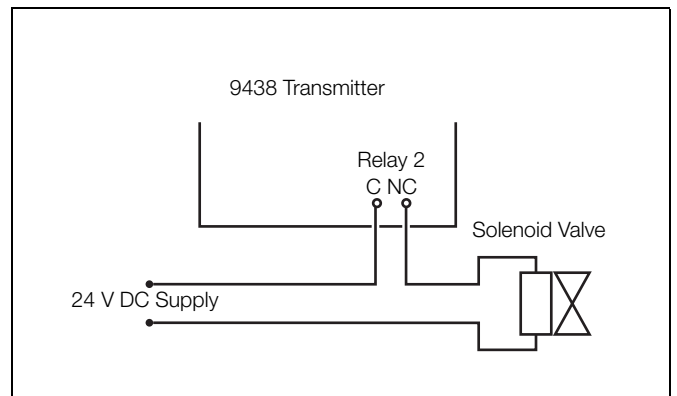

Solenoid Valve Powered from User-supplied 24 V DC Source

### Overall Dimensions

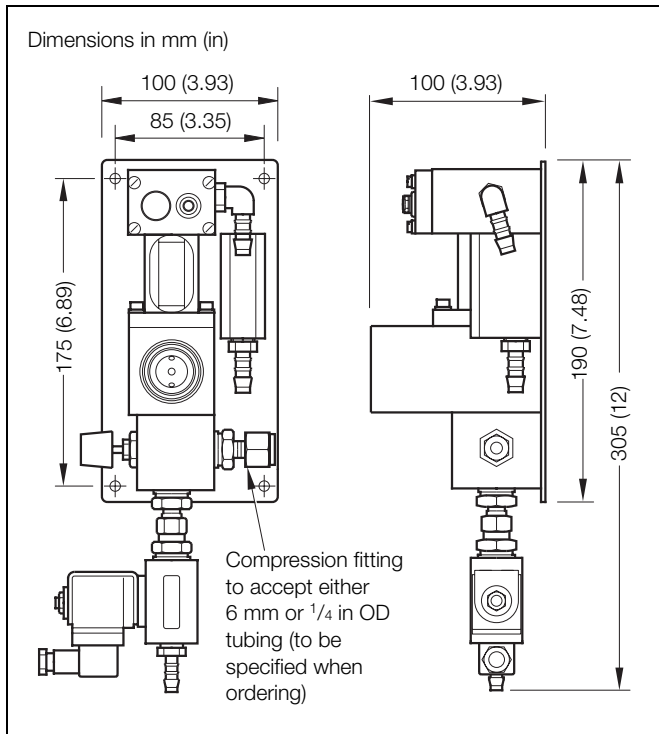

Liquid Handling Panel

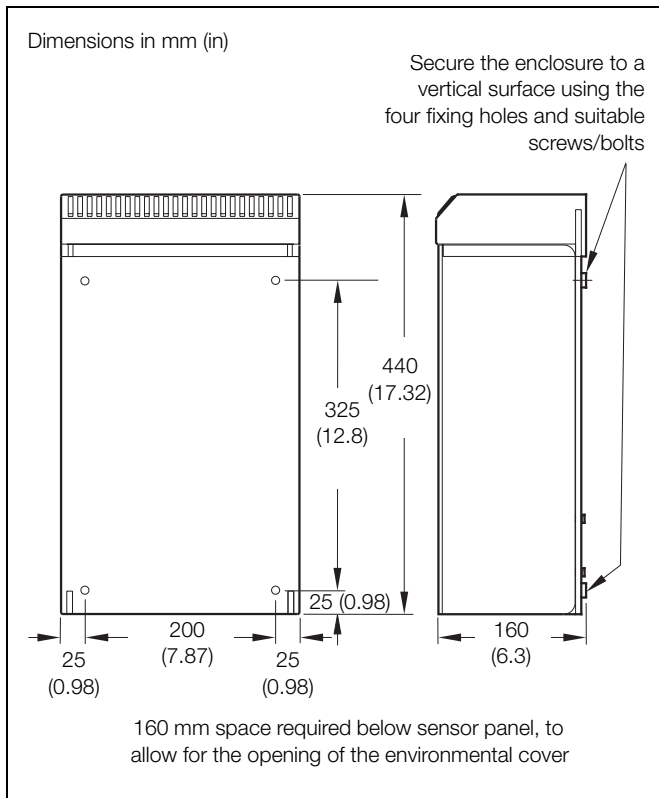

Liquid Handling Enclosure

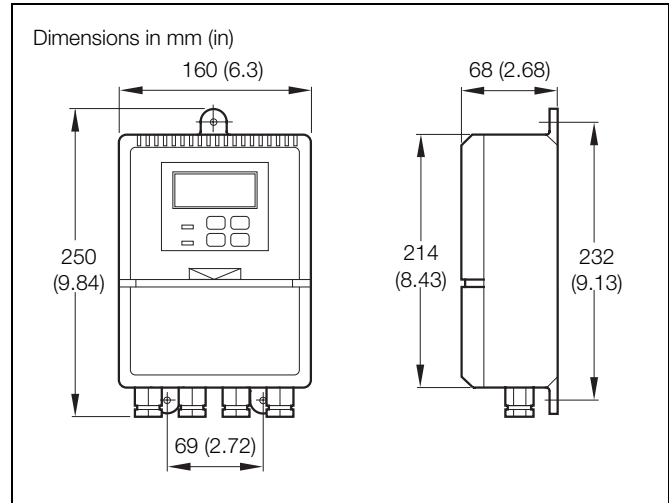

Wall-mount Transmitter

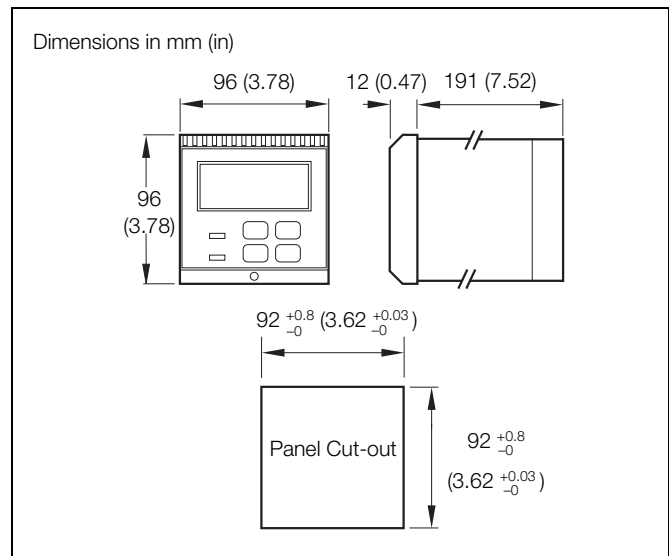

Panel-mount Transmitter

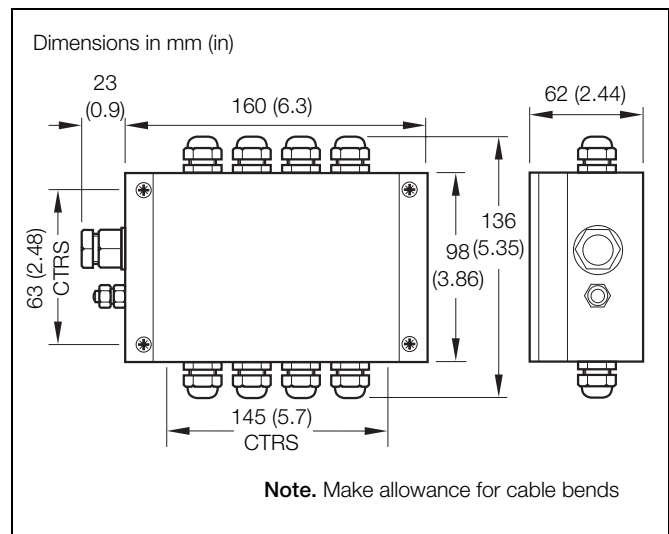

Solenoid Valve Power Supply Unit

**Ordering Information**

Model 9438 Low and High Level Dissolved Oxygen Monitor	9438/00	X	X	X	X	X	X
<b>Fitting, Capsule, Enclosure</b>							
Standard 6 mm fitting, with capsule & liquid-handling enclosure	0						
Standard 6 mm fitting, without capsule, with liquid-handling enclosure	1						
Standard 6 mm fitting, with capsule, without liquid-handling enclosure	2						
Standard 6 mm fitting, without capsule & liquid-handling enclosure	3						
Standard 1/4 in fitting, with capsule & liquid-handling enclosure	4						
Standard 1/4 in fitting, without capsule, with liquid-handling enclosure	5						
Standard 1/4 in fitting, with capsule, without liquid-handling enclosure	6						
Standard 1/4 in fitting, without capsule & liquid-handling enclosure	7						
<b>Transmitter Type – Electronics</b>							
Wall-mount	0						
Panel-mount	1						
Wall-mount, US market specification	2						
Panel-mount, US market specification	3						
<b>Output</b>							
Current output only				0			
Current output + serial data interface RS485 Modbus compatible				1			
Two current outputs				2			
<b>Valve PSU</b>							
With 24 V DC valve PSU					0		
Without 24 V DC valve PSU					1		
<b>2nd Cable Length (Sensor to Transmitter)</b>							
1 m (3 ft)						0	
5 m (15 ft)						1	
10 m (30 ft)						2	
30 m (100 ft)						3	
<b>Language</b>							
English							0
German							1
French							2
Spanish							3

**ABB** has Sales & Customer Support expertise  
in over 100 countries worldwide

[www.abb.com](http://www.abb.com)

The Company's policy is one of continuous product  
improvement and the right is reserved to modify the  
information contained herein without notice.

Printed in UK (03.09)

© ABB 2009



**ABB Limited**  
Oldends Lane,  
Stonehouse  
Gloucestershire  
GL10 3TA  
UK  
Tel: +44 (0)1453 826661  
Fax: +44 (0)1453 829671

**ABB Inc.**  
125 E. County Line Road  
Warminster  
PA 18974  
USA  
Tel: +1 215 674 6000  
Fax: +1 215 674 7183