

AW400 cell
Chlorine / Chlorine dioxide / Ozone



The Company

We are an established world force in the design and manufacture of measurement products for industrial process control, flow measurement, gas and liquid analysis and environmental applications.

As a part of ABB, a world leader in process automation technology, we offer customers application expertise, service and support worldwide.

We are committed to teamwork, high quality manufacturing, advanced technology and unrivalled service and support.

The quality, accuracy and performance of the Company's products result from over 100 years experience, combined with a continuous program of innovative design and development to incorporate the latest technology.

EN ISO 9001:2000



Cert. No. Q 05907

EN 29001 (ISO 9001)



Lenno, Italy – Cert. No. 9/90A

Stonehouse, U.K.



Electrical Safety

This equipment complies with the requirements of CEI/IEC 61010-1:2001-2 'Safety Requirements for Electrical Equipment for Measurement, Control and Laboratory Use'. If the equipment is used in a manner NOT specified by the Company, the protection provided by the equipment may be impaired.

Symbols

One or more of the following symbols may appear on the equipment labelling:

	Warning – Refer to the manual for instructions
	Caution – Risk of electric shock
	Protective earth (ground) terminal
	Earth (ground) terminal

	Direct current supply only
	Alternating current supply only
	Both direct and alternating current supply
	The equipment is protected through double insulation

Information in this manual is intended only to assist our customers in the efficient operation of our equipment. Use of this manual for any other purpose is specifically prohibited and its contents are not to be reproduced in full or part without prior approval of the Technical Publications Department.

Health and Safety

To ensure that our products are safe and without risk to health, the following points must be noted:

1. The relevant sections of these instructions must be read carefully before proceeding.
2. Warning labels on containers and packages must be observed.
3. Installation, operation, maintenance and servicing must only be carried out by suitably trained personnel and in accordance with the information given.
4. Normal safety precautions must be taken to avoid the possibility of an accident occurring when operating in conditions of high pressure and/or temperature.
5. Chemicals must be stored away from heat, protected from temperature extremes and powders kept dry. Normal safe handling procedures must be used.
6. When disposing of chemicals ensure that no two chemicals are mixed.

Safety advice concerning the use of the equipment described in this manual or any relevant hazard data sheets (where applicable) may be obtained from the Company address on the back cover, together with servicing and spares information.

TABLE OF CONTENTS

1.0 INTRODUCTION.....	2
1.1 General description	2
1.2 Ordering Information	3
1.3 Accessories.....	3
1.4 Consumables	3
1.5 AW400 Specification	4
1.6 Electrodes	5
1.7 Mounting dimensions	6
2.0 INSTALLATION.....	7
2.1 Inspection.....	7
2.2 Sampling Requirements.....	7
2.3 Location.....	7
2.3.1 Sample line connection.....	11
2.3.2 Sample connection	11
2.4 Electrical connections	12
2.4.1 Measuring cell electrical connections	12
2.4.2 Buffer Feeder Mains Power	13
3.0 START-UP	14
4.0 FUNCTIONAL DESCRIPTION.....	15
5.0 Use of Reagent Feeder Assembly	16
5.1 Measures of free residual chlorine.....	16
5.2 Measures of total chlorine	17
6.0 MAINTENANCE	18
6.1 Periodic functional check	18
6.2 Cleaning or Replacement of electrodes.....	18
6.3 Peristaltic Tube Replacement (Reagent Feed Systems Only).....	19
7.0 TROUBLESHOOTING	20
8.0 PART LIST	21

1.0 INTRODUCTION

Drinking water, cooling water and industrial water are usually disinfected with chlorine, chlorine dioxide or ozone. The level of disinfectant in these waters must be carefully controlled, since insufficient disinfection is to be avoided and too high chlorine concentrations lead to undesirable tastes and piping corrosion. The AW400 allows the automatic control of chlorine dosages in such systems.

The instructions given herein cover general description, installation, operation and maintenance of the AW400 series sensor and accessories.

1.1 General description

The application of this measuring system, consisting of a sensing device and a transmitter instrument, serves to the combined function of measuring, indicating and retransmitting the chlorine/chlorine dioxide or ozone concentration in a sample.

The sensor is an amperometric cell consisting of two concentric electrodes. The inner spiral is the gold measure electrode, the copper cylinder is the counter-electrode. The water sample flows into the electrodes chamber through nozzles that are located in the copper cylinder. A measured amount of a special Corundum sand placed into the cell is moved by the water and acts as an abrasive on the electrodes, keeping them sensitive.

The measuring cell is provided with a differential pressure regulator filter, that maintains a constant water flow even in presence of input pressure fluctuations between 0.2 and 4.0 bar (2.9 and 58 psi).

The signal is compensated for temperature variations through an integrated thermistor (PT100) that reads sample's temperature.

1.2 Ordering Information

Residual Chlorine Monitor	AW4	XX	X	X	X	X
Transmitter Type						
Transmitter		01				
Transmitter with PID Control (Channel 1 only)		02				
Sensor Type Channel 1						
Chlorine Cell			1			
Sensor Type Channel 2						
No second input channel				0		
Chlorine Cell				1		
pH				6		
ORP				7		
Additional 4-20mA input/output (re-transmission or flow input)				8		
Sensor Type Channel 3						
No third input channel					0	
Chlorine Cell					1	
pH					6	
ORP					7	
Transmitter Voltage						
115V AC 50/60 Hz						1
230V AC 50/60 Hz						2

1.3 Accessories

Residual Chlorine Reagent Feeder Assemblies*

Reagent Feeder Assembly (Free Chlorine 115V AC)	AW401 011
Reagent Feeder Assembly (Free Chlorine 230V AC)	AW401 012
Reagent Feeder Assembly (Total Chlorine 115V AC)	AW401 013
Reagent Feeder Assembly (Total Chlorine 230V AC)	AW401 014

*Comes complete with tubing and reagent bottles

1.4 Consumables

Cell Maintenance Kit	AW401 022
Includes replacement gold and copper electrodes, corundum sand and O rings	
Replacement Gold Electrode	AW401056
Replacement Copper Electrode	AW401057
Corundum Sand	AW401023
Replacement pH electrode	1413253
Replacement Redox electrode	1184603
Replacement Peristaltic Tubing*	AW401024
Tubing/Container Kit for Free Cl ₂ *	AW401025
Tubing/Container Kit for Total Cl ₂ *	AW401026
Tubing for reagent feed assembly - Free Cl ₂ *	AW401027
Tubing for reagent feed assembly - Total Cl ₂ *	AW401028
*used on buffer feed assembly	

1.5 AW400 Specification

Measurement Range

Chlorine, Chlorine Dioxide, Ozone 0 to 20 ppm (mg/l)

Measurement Mode

Measurement technology Amperometric cell

Measurement interval Continuous

Measurement Performance

Accuracy Unbuffered: 2% or ± 0.01 10ppb, whichever is the greater at pH <7.5
Buffered: 2% or ± 10 ppb, whichever is the greater at <pH 10

Sensitivity 0.001 ppm

Minimum Detection Limit 0.005 ppm

Drift Zero drift: $\pm 1\%$ over 30 days Max.
Span drift: -5% over 30 days Max.

Response Time 90% in less than 90 seconds

Interferences Samples containing high concentrations of metal ions or other strong oxidants may affect analyzer operation

Environmental Data

Ambient Operating Temperature -10°C to $+50^{\circ}\text{C}$

Ambient Operating Humidity 80% RH at 31°C , with linear decrease down to 50% RH at 40°C

Sample Temperature Compensated between 2 and 50°C (36°F and 122°F).

Sample Inlet Pressure 0.2 to 4.0 bar (3 to 60 psi). For pressures over 4 bar (60 psi) install a pressure reducing valve. Recommended operating pressure is 2 bar (30 psi)

Sample Outlet Pressure Pressureless

Sample Flow Continuous, 60 - 75 l/hr

Sample pH Value 4 to 7.5 (Buffer feed assembly available for pH greater than 7.5). No correction is needed when measuring chlorine dioxide and ozone.

Maintenance

Maintenance Interval	Recommended annual replacement of O-rings and electrodes
Calibration	single or two-point manual calibration Comparison of lab method with process sample or de-chlorinated

Cell Construction Material

Electrodes	Gold / Copper
Electrode chamber	plexiglas
Differential pressure regulator	PVC

Mechanical Data

Ingress Protection	
Transmitter	IP65
Measurement Cell	IP64
Sample connections	
Inlet/Outlet:	3/8" OD polyethylene or flexible PVC tubing

Electrical

Mains voltage	115 Vac, \pm 10%, 50/60 Hz 230 Vac, \pm 10%, 50/60 Hz
Maximum Consumption	20 VA

Certifications

CE

1.6 Electrodes

The cell is made of two concentric electrodes, the gold spiral electrode and the copper cylinder electrode. The sample water enters into the cell, in which a differential pressure regulator maintains a constant water flow even in presence of input pressure fluctuations between 0.2 and 4.0 bar (2.9 and 58 psi).

The water sample enters tangentially in the electrode chamber and the gritting action of the sand keeps the electrodes sensitive. The presence of the sand allows long periods of operation without necessity of maintenance on the cell. The cell widens upwards so allowing the sand to drop into the hydraulic low pressure section and recycle down in the electrode chamber. An integrated filter prevents the loss of sand through the overflow that may occur in cases of excessive air bubbling through the cell.

1.7 Mounting dimensions

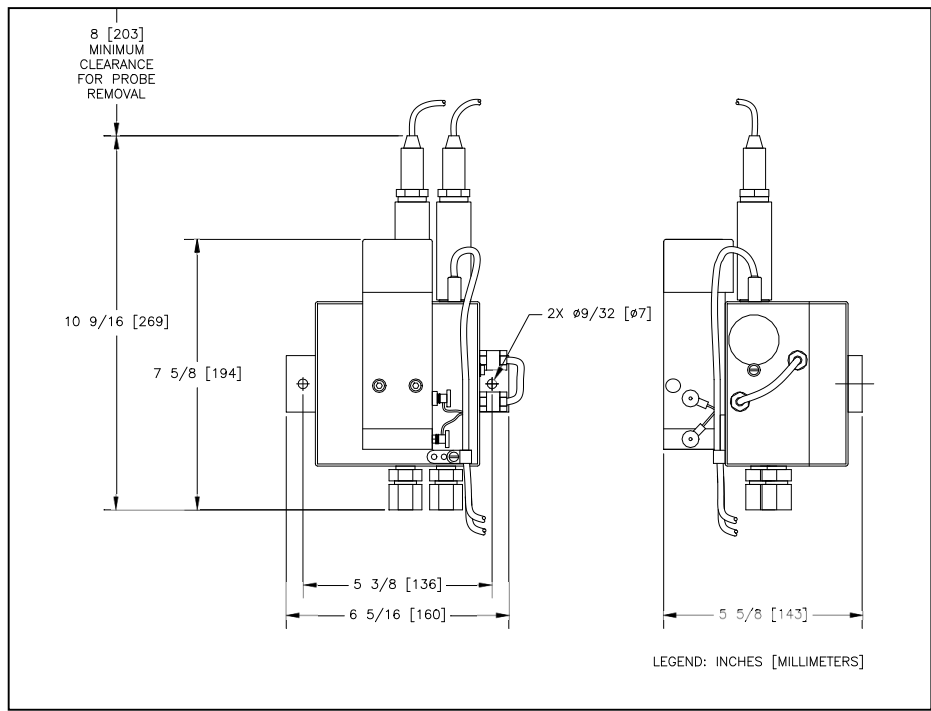

Fig. 1 AW400 Measurement Cell Mounting dimensions

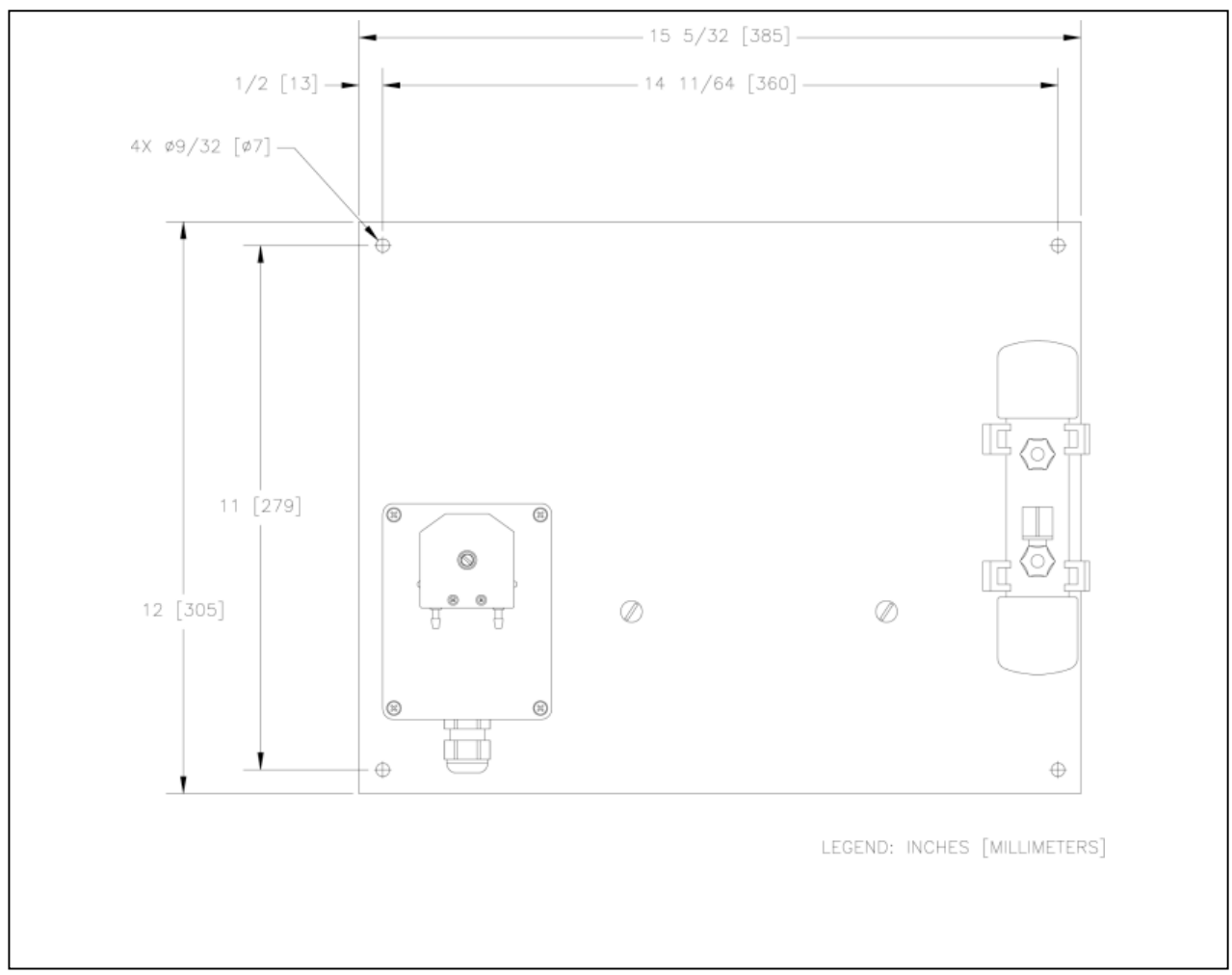

Fig. 2 Reagent Feeder Assembly, Mounting dimensions

2.0 INSTALLATION

2.1 Inspection

ABB takes all possible precautions in packing each equipment item to prevent damages during shipment. However it's advisable to carefully inspect each item and, if damage has occurred, report it immediately. Damage claims should be reported to the shipping agent involved for the equipment.

Do not install any equipment if damage is such that faulty operation is likely to result. **Carefully inspect all packing material before discarding it to prevent loss of mounting hardware, accessories, spare parts or instructions.**

2.2 Sampling Requirements

Selection of a good, representative sampling point is critical to obtain optimum performance from the analyzer.

To reduce sample dead time, locate the analyzer as close to the sampling point as possible.

The sample must also conform to the following conditions:

- Sample flow must be continuous, with a rate between 60 l/hr and 75 l/hr.
- Sample temperature must be within the range 2 to 50 °C.
- Samples must not contain particles exceeding 100 microns in size. Above these levels, an external filter must be fitted to the sample lines.
- Sample pressure must be greater than 0.2 bar and less than 4.0 bar.
- Sample must be free of any air bubbles.
- Sample must be thoroughly mixed and representative of the process.

2.3 Location

Install in a clean, dry, well ventilated location providing easy and safe access for operators to maintain and calibrate the analyzer. The location must also comply with the following requirements:

- It must be free of vibrations.
- The cell must not be exposed to direct sunlight.
- It should be as far as possible from rotating or electrical communication devices.
- The transmitter should be located near to the cell in order to be able to conduct the periodic calibration.
-

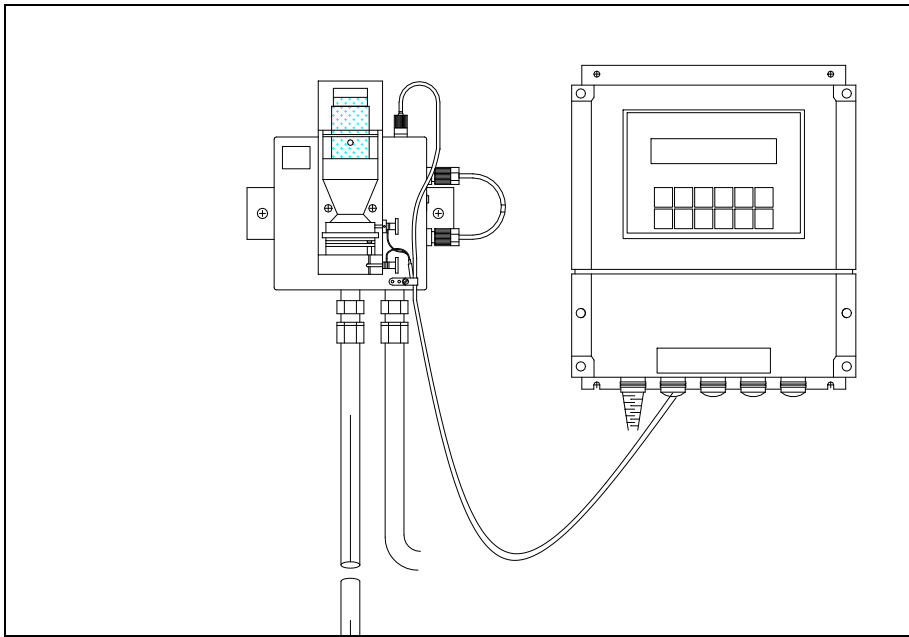

Fig. 3 Suggested installation without reagent feeder

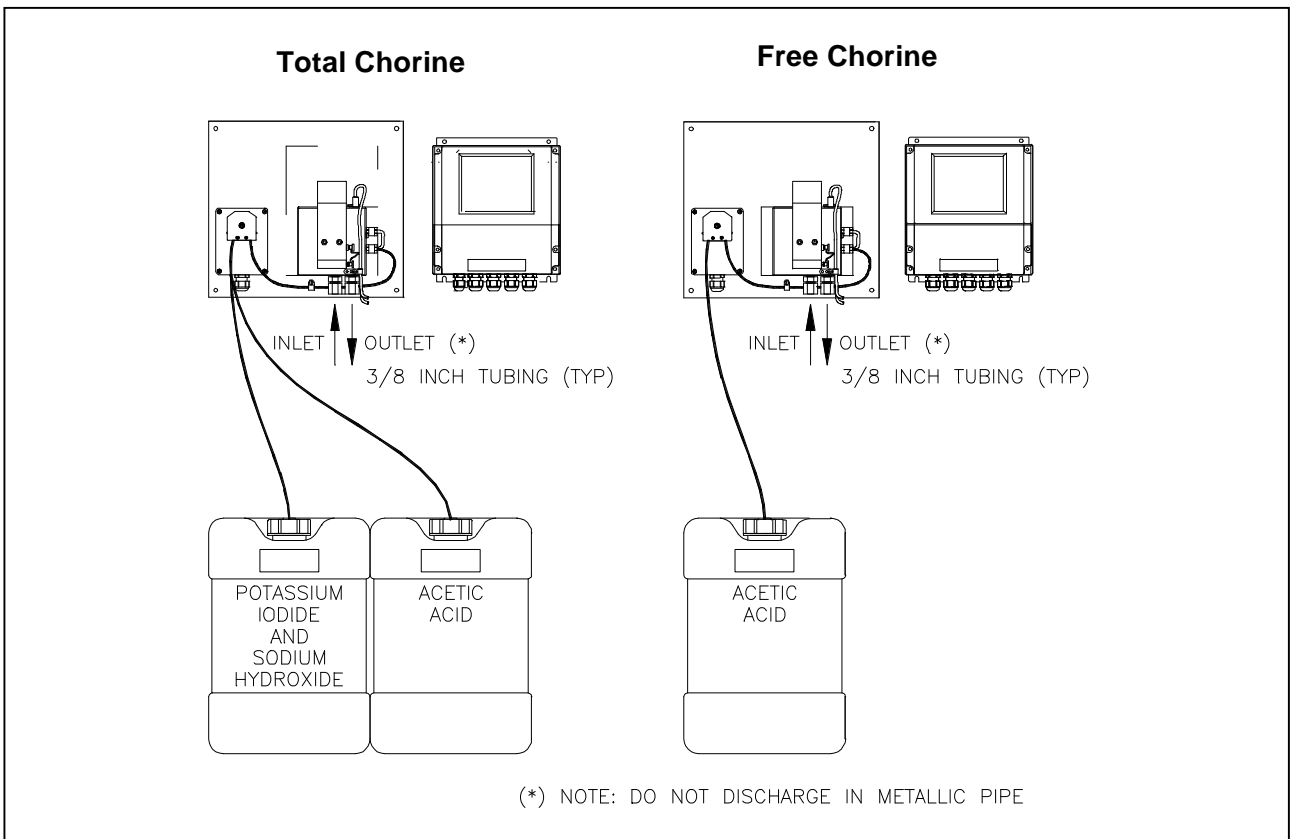

Fig. 4 Suggested installation with reagent feeder

Preparation before the installation

The AW400 measuring cell family is designed to be wall mounted. Mounting hardware is supplied.

Attach the AW400 measuring cell to the wall with the supplied mounting screws through the designated mounting holes.

No reagent feeder

When installing the measuring cell without the reagent feeder option, be sure to attach the supplied shunt tubing assembly (a, Fig. 5) to the two fittings located on the right side of the measuring cell assembly. Complete the assembly by installing the rectangular mounting bracket to the back of the measuring cell using the supplied screws.

Free Chlorine Reagent Feeder

When installing the measuring cell with the Free Chlorine Reagent Feeder, be sure to attach the supplied Free Chlorine reagent tubing assembly (b, Fig. 6) to the two fittings located on the right side of the measuring cell assembly. Connect the attached tube (b1, Fig. 6) to the barb on the outlet side of the peristaltic pump. The shunt tube (a, Fig. 6) should be saved in the event that the application changes and the reagent feeder becomes unnecessary.

Set aside the rectangular mounting bracket and install the square mounting bracket furnished with the reagent feeder panel to the back of the measuring cell using the supplied screws. Complete the assembly by fastening the rectangular mounting bracket and cell to the reagent feeder panel using the supplied screws.

Remove the tubing assembly from the supplied 30.2 l (8 gal) reagent container. Insert the weighted end of the tubing assembly into the container and connect the other end to the barb on the inlet side of the peristaltic pump.

Total Chlorine Reagent Feeder

When installing the measuring cell with the Total Chlorine Reagent Feeder, be sure to attach the supplied Total Chlorine reagent tubing assembly (c, Fig. 6) to the two fittings located on the right side of the measuring cell assembly. Connect the attached tubes (Fig. 5) to the two barbs on the outlet side of the peristaltic pump.

Set aside the rectangular mounting bracket and install the square mounting bracket furnished with the reagent feeder panel to the back of the measuring cell using the supplied screws. Complete the assembly by fastening the rectangular mounting bracket and cell to the reagent feeder panel using the supplied screws.

Remove the tubing assemblies from each of reagent containers. Insert the weighted ends of the tubing assemblies into the containers and connect the other ends to the barbs on the inlet side of the peristaltic pump.

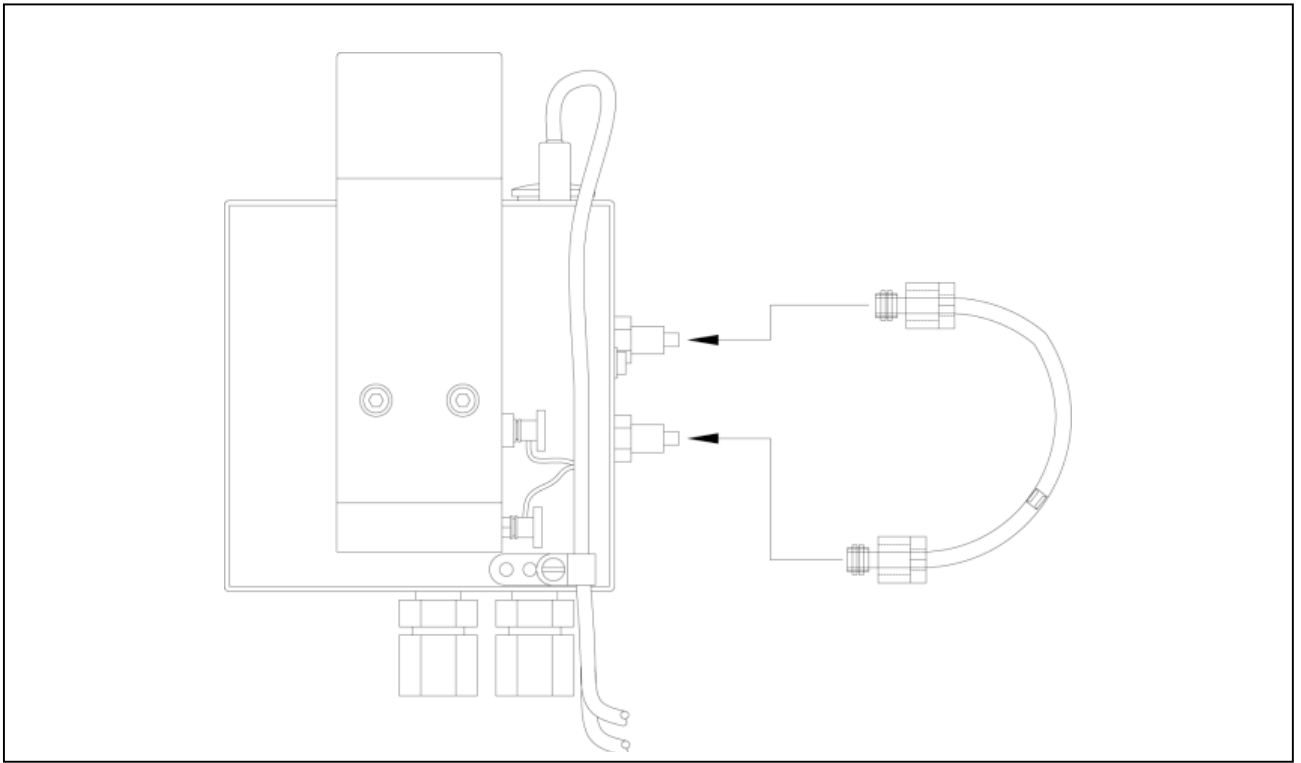

Fig. 5 Measuring Cell Tubing Connection

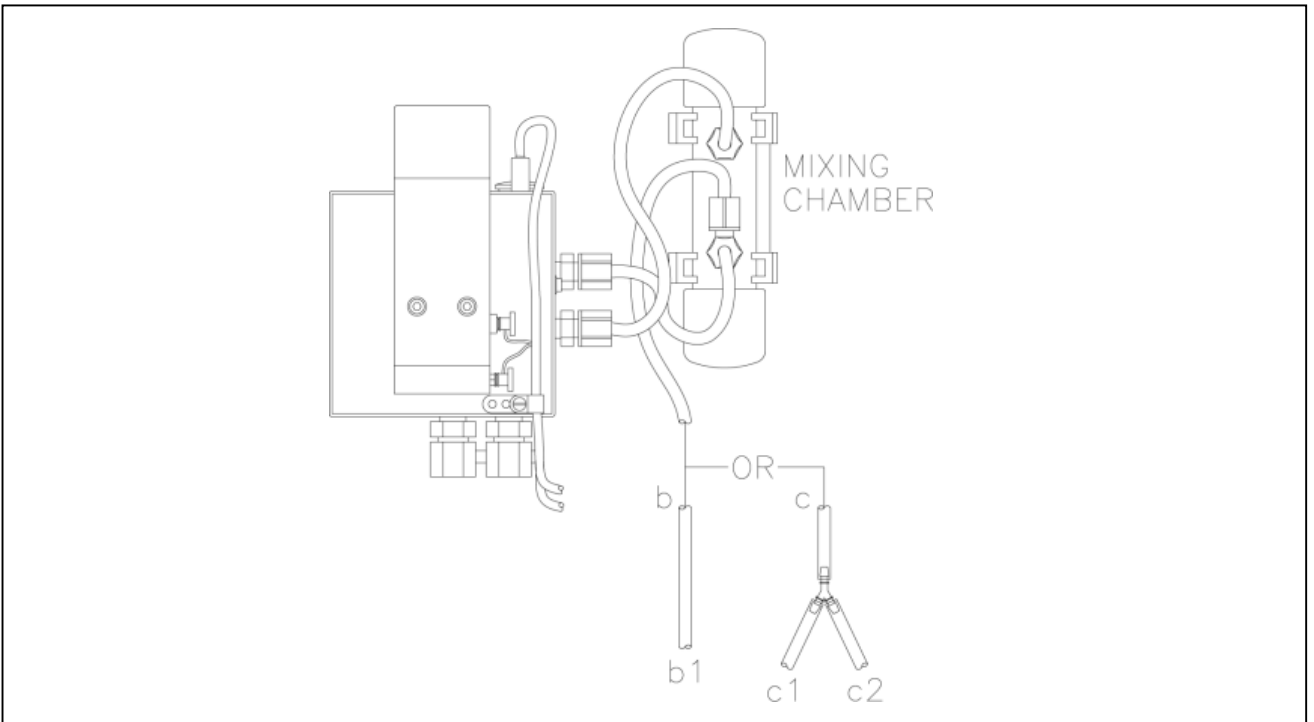

Fig. 6 Measuring Cell/Mixing Chamber Tubing Connections

2.3.1 Sample line connection

Sufficient water sample pressure must be available so that the water transfer time is as short as possible, to reduce system time lag.

For pressure over 4 bar install a pressure reducer and set pressure into the allowable range (typically 2 bar). When the sample enters the cell for gravity allow a minimum hydraulic head of two meters. Use polyethylene tubing or PVC piping for water sample transfer.

WARNING !

*The soft overflow tube must not be shortened and must drain freely without back pressure.
Do not discharge water sample in metal piping as corrosion may occur.*

The transmitter should be located near the cell and over it, for convenience in the periodic calibration. Connect the transmitter according to the instructions given in the Instruction Manual pertinent of the AW400.

2.3.2 Sample connection

To connect the sample line use a polyethylene or flexible PVC tubing, with external diameter 3/8". Unscrew the adapter on the lower part of the cell, insert the hose and replace the adapter.

Insert the drain hose about 10 - 15 cm (3.9 – 5.9 in) in a non-metal pipe. In this way an easy hose removal is allowed for sample collection which is necessary for periodic calibration.

2.4 Electrical connections

2.4.1 Measuring cell electrical connections

Connect the measuring cell to the transmitter as described in the transmitter's Instruction Bulletin. The sensor is supplied with cables for the measuring cell and for the PT100 thermistor.

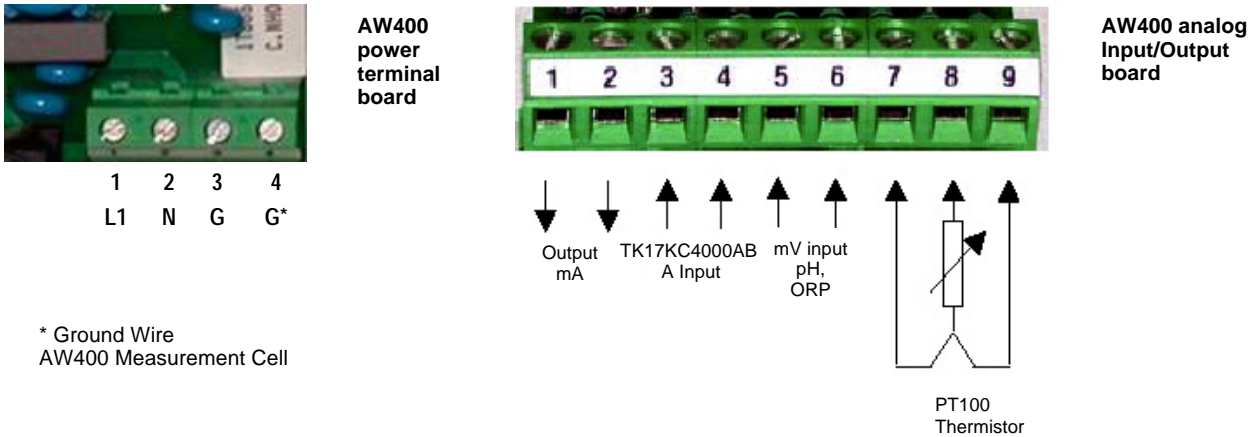

Fig. 7 Electrical Connections of the Measuring Cell

The measuring cell is connected to terminals 3 and 4 on the AW400 analog input/output board and the ground wire is connected to terminal 4 of the power terminal board (Fig. 7).

The optional pH and/or ORP probes are connected to terminals 5 and 6 (separate input cards required), the PT100 is connected to terminals 7, 8 and 9 of the appropriate analog input/output board (Fig. 7).

The cell wires are marked with terminal designations 3, 4 and G and the PT100 wires are marked 7,8, and 9.

2.4.2 Buffer Feeder Mains Power

CAUTION !

Only qualified personnel should conduct the tasks described in this section of the manual.

The buffer feeder pump requires a single-phase power source. The buffer feed motor can be wired to either a 110 VAC or 220/240 VAC supply as appropriate. All models require a cable and plug to be fitted before use. The voltage to ground from either pole of the power source must not exceed the maximum rated operating voltage, 130 for 110 VAC supply or 264 VAC for the 220-240 VAC supply. Before making connection to the power source, determine that the voltage of the power source is correct. The power source must have a fuse or circuit breaker rated no higher than 1 A, and be supplied via a suitable disconnection device i.e. a switch.

To fit a power cable to the buffer feed pump, unscrew the 4 retaining screws on the buffer pump assembly. Locate the 3 wires attached to the buffer feed motor and identify the two black leads as shown below in Fig.8 (L1 and L2). Attach a suitable power lead to the motor leads as local regulations permit.

Connect the power lead earth ground to the side case of the motor as shown in Fig. 8, pass the power lead through the cable gland and tighten the gland, this ensures a waterproof and robust seal around the power lead.

Reassemble the enclosure ensuring no wires or leads are trapped.

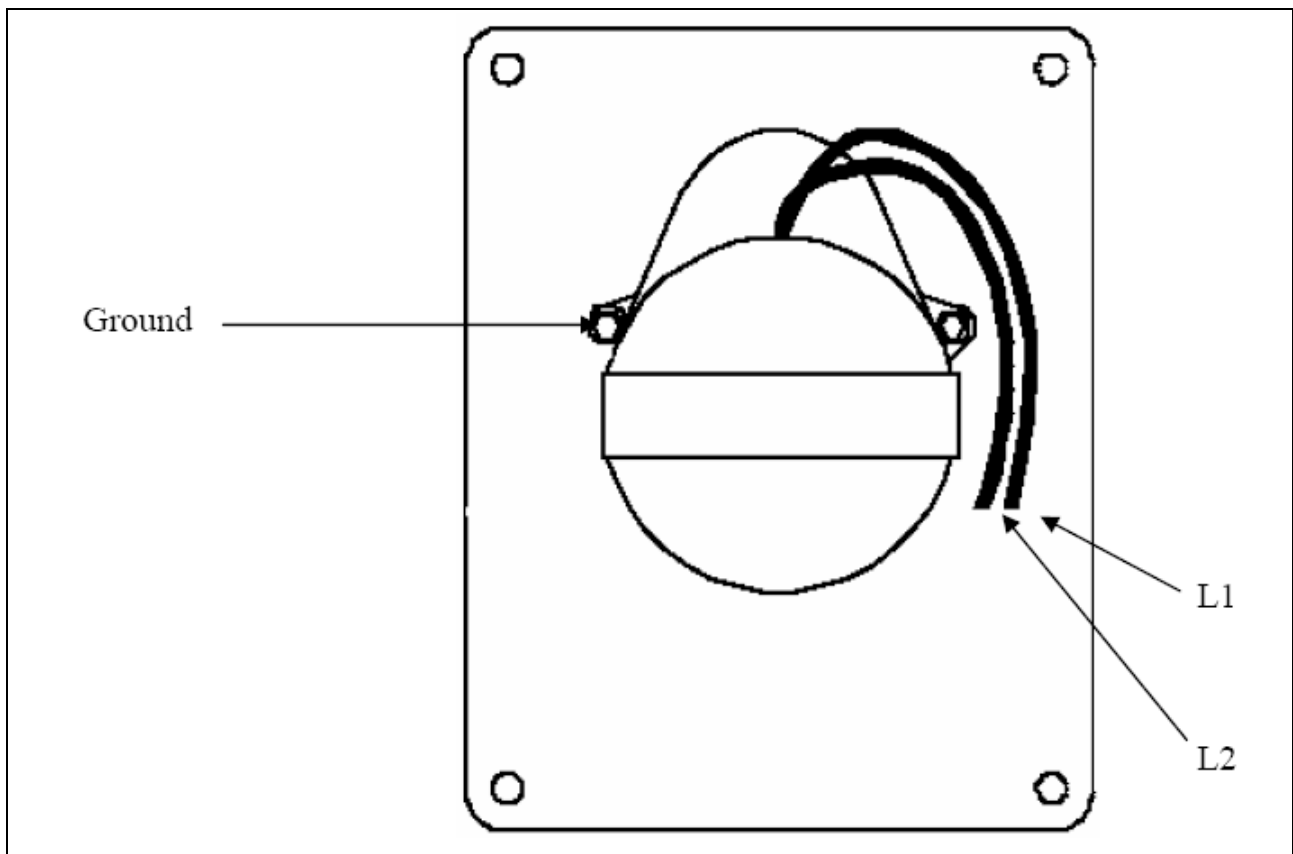

Fig. 8 Sensing module power connections

3.0 START-UP

Check the entire installation is connected properly.

Open all valves in the sample water line and wait till the water flows steadily from the overflow tube. Stop the water flow. Open the cell body cover pulling it up with a twisting motion. Pour into the water in the cell ONE LEVELLED SPOON of the supplied Corundum sand. Replace the cover and restart the water flow.

If a flow meter is not installed, check water sample flow by collecting the overflow water in a graduated vessel:

Cell Type	Time taken to collect ½ l
AW400 Measurement Cell	20 – 30 sec.

This is the correct water flow in order to keep the Corundum sand working.

Now the cell is ready for operation. Open the sample flow and wait about 24 hours before starting the calibration, since the electrodes working surfaces require time for stabilisation.

WARNING !

The calibration has to be performed at the start up in the presence of the AW400 transmitter. Please find the instructions related to the procedure in the Instruction Manual of AW400.

All the substitutions or the cleaning of the electrodes require a new start-up: always make sure the required amount of Corundum sand is swirling in the body.

WARNING !

Never ADD Corundum sand in the body, but always CHANGE it completely.

4.0 FUNCTIONAL DESCRIPTION

The AW400 measuring cell is an electrochemical cell and it is polarized because of the normal potential of the two different metal electrodes. When an oxidising substance (chlorine/chlorine dioxide/ozone) is present in the sample between the electrodes, the measuring (gold) electrode is depolarised and the counter-electrode (copper) dissolves as Cu^{++} . In the process of the reaction, electrons transfer from the copper electrode to the gold electrode through an electrically conducting path as an electric current. The number of electrons that move from an electrode to another is the same as that of electrons that are captured by chlorine/chlorine dioxide/ozone at the measuring electrode. So the cell generates a signal (current) which is proportional to the chlorine/chlorine dioxide/ozone concentration in the sample. The signal is compensated for temperature variations via software in the AW400 transmitter through a PT100 thermistor. The transmitter works out a digital signal of sample's chlorine/chlorine dioxide/ozone concentration and a proportional current signal between 4-20 mA.

5.0 Use of Reagent Feeder Assembly

Measurements of total chlorine require a reagent to be added. Sometimes a reagent buffer is also needed for free residual chlorine measurements.

For chlorine dioxide/ozone/ measurements the sample conditioning is not necessary.

5.1 Measures of free residual chlorine

Normally the measure of free chlorine with this analyser doesn't require any sample conditioning. However, when the sample pH is fluctuating or it is vastly high, a pH buffering solution is required. Fig.9 shows the allowable pH fluctuations in the sample, as a function of the pH value of the sample.

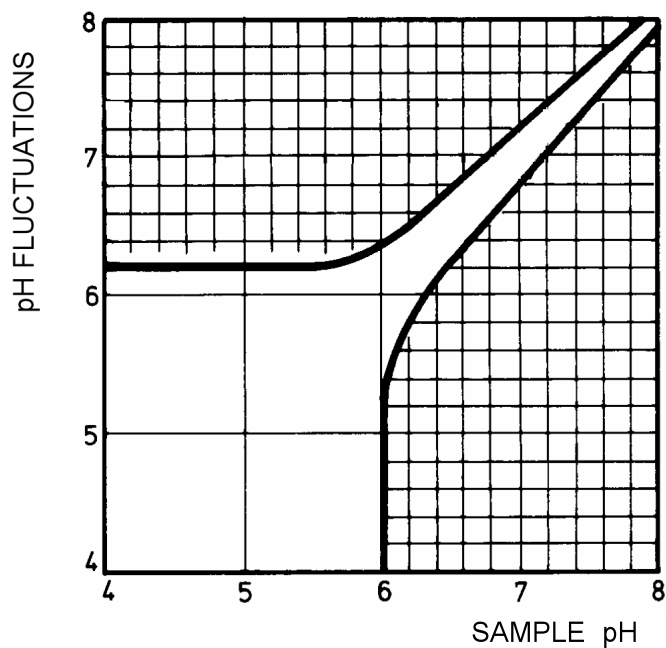

*Fig. 9 Allowable pH Fluctuation Envelope
Shaded Area = conditions requiring
pH buffering solution.*

When the pH increases over 6.0 the allowable variations decreases to approximately 0.5 pH units or less; the higher the pH value the lower the allowable fluctuations. In such cases, and always when the sample pH is over 7.5, a special additive is required for pH control.

ABB supplies the complete reagent feeder system, able to dose the right amount of buffer solution. It is represented in Fig 2.

WARNING !

*Ensure personal protective equipment (PPE) such as gloves and eye protection are worn when handling chemicals and that any spillages are cleaned-up
Observe all health and safety procedures for handling chemicals.*

To prepare **pH buffer (Acetic acid solution)** follow these instructions:

1. Weight 2430 g (5.36 lb) of sodium acetate tri-hydrate ($\text{CH}_3\text{COONa}\cdot 3\text{H}_2\text{O}$) and dissolve completely in 4 l (1 gal) of distilled water.
2. Add, while mixing, 4800 g (10.58 lb) of glacial acetic acid (98-100 % CH_3COOH).
3. Mix thoroughly, then add distilled water to obtain 10 l (2.6 gal) of solution.

The pH value of this solution is about 4.3 at 20 °C (68 °F).

The buffer may be transferred to the 30.2 l (8 gal) container (marked Acetic Acid) provided with the reagent feeder. The buffer's consumption is approximately 10 liters (2,6 gal) in 30 days.

IMPORTANT:

Use only pure chemicals. Use only polyethylene or glass vessels, other materials may be corroded, causing errors in measure. Do not use dirty reagents, or reagents in presence of a solid deposit.

5.2 Measures of total chlorine

The AW400 measuring cell allows total chlorine measurements by simply conditioning the sample with reagents.

The reagent feeder for total chlorine is supplied with two 30.2 l (8 gal) for each container (marked "Acetic Acid" and marked "Potassium Iodide and Sodium Hydroxide"). Fill up the containers with the solutions prepared like following instructions:

Reagent #1 (Acetic acid solution)

Follow the same instructions as those reported in Section 5.1 to prepare pH buffer.

Reagent #2 (Potassium Iodide and Sodium Hydroxide Solution)

1. In the 30,2 l (8 gal) container marked "Potassium Iodide and Sodium Hydroxide" (Reagent #2), dissolve 454 g (1 lb) of sodium hydroxide pellets in 15.15 l (4 gal) of distilled or deionized water.
2. When the sodium hydroxide has cooled to ambient temperature, add the required quantity of potassium iodide (See table below).
3. Mix by stirring the solution with a PVC or polyethylene rod.

Solution consumption is approx 10 l (2,6 gal) in 30 days.

Range (ppm)	Potassium Iodide (g)
0 – 0.25	37.5 [1.32 oz]
0 – 0.50	75 [2.64 oz]
0 – 1.0	150 [5.29 oz]
0 – 2.0	300 [10.58 oz]
0 – 5.0	750 [1.65 lb]
0 – 10.0	1500 [3.30 lb]

6.0 MAINTENANCE

6.1 Periodic functional check

The measuring cell, like other analyzers, should be checked once a week to assure the best measurement accuracy.

6.2 Cleaning or Replacement of electrodes

If the cell sensitivity is vastly reduced it may be an indication of copper electrode damage. To replace it see the following instructions.

If the cell sensitivity is reduced it is an indication that cleaning the electrodes or replacing the copper cell is necessary.

- Remove both signal leads at the cell.
- Pull the gold electrode fitting in the cell downward, thereby exposing the entire electrode chamber.
- The Corundum sand escapes with the water contained in the cell, and will have to be replaced.
- To remove all the sand, loosen the gold electrode fitting and open the water sample. Refill the chamber and then remove the fitting to drain.
- Otherwise, when it's possible, pull out the cell cover, and flush the open cell with a squirt bottle filled with distilled or clean water.
- Sand prevents good O-ring sealing and must be completely removed.
- Stop the water flow.
- Gently clean the gold electrode with a Q-tip and a detergent that does not leave a residue, such as Bon Ami Cleanser. Rinse the electrode with clean water.
- Remove the knurled nut on the cell body. Remove the holding screw from the copper electrode.
- Now the copper electrode can be removed by lightly tapping on a soft surface.
- Check the condition of the copper electrode. Excessive grooving or wear to the copper electrode indicates replacement is necessary. The electrode should be cleaned to produce a uniform shiny copper appearance. A non-chlorinated cleanser or a mild abrasive such as a Scotch Brite pad can be used to clean the copper electrode.
- Reinstall the copper electrode.
- Reinstall the gold electrode assembly and add the correct quantity of sand.
- Restore sample flow.

Make sure the sealing surfaces and tight fits are free of sand.
Flush away any sand as described in the preceding paragraph.

6.3 Peristaltic Tube Replacement (Reagent Feed Systems Only)

The peristaltic pump tubing should be changed every **three months**. An initial supply of tubing has been included with the reagent feeder providing enough tubing for one year. Systems for Free Chlorine will have one peristaltic pump tube and one reagent pickup tube, systems for Total Chlorine will have two peristaltic pump tubes and two reagent pickup tubes.

Prior to removing the pump tubing, carefully remove the pickup tubing from the reagent bottle(s) and place into a container of tap water. Allow the pump to run for a period of 15 minutes.

Note. Do not replace the pump tubing without first purging with water.

Pump tubing replacement is easy and can be performed in just a few minutes. First disconnect power from the reagent feeder. Once the power is removed, gently press on the sides of the clamp plate (Fig.10) and pull upwards. Gently pull the two retaining blocks from both sides of the pump and remove the tubing assembly from the pump.

The replacement tubes are cut to length and include with barb fittings. Remove the old tubing assembly from the retaining blocks and install the new tubing assembly.

Reinstall the tubing assembly with retaining blocks and the clamp plate, and reinsert the pickup tubing in the reagent bottle(s) before reinstalling power.

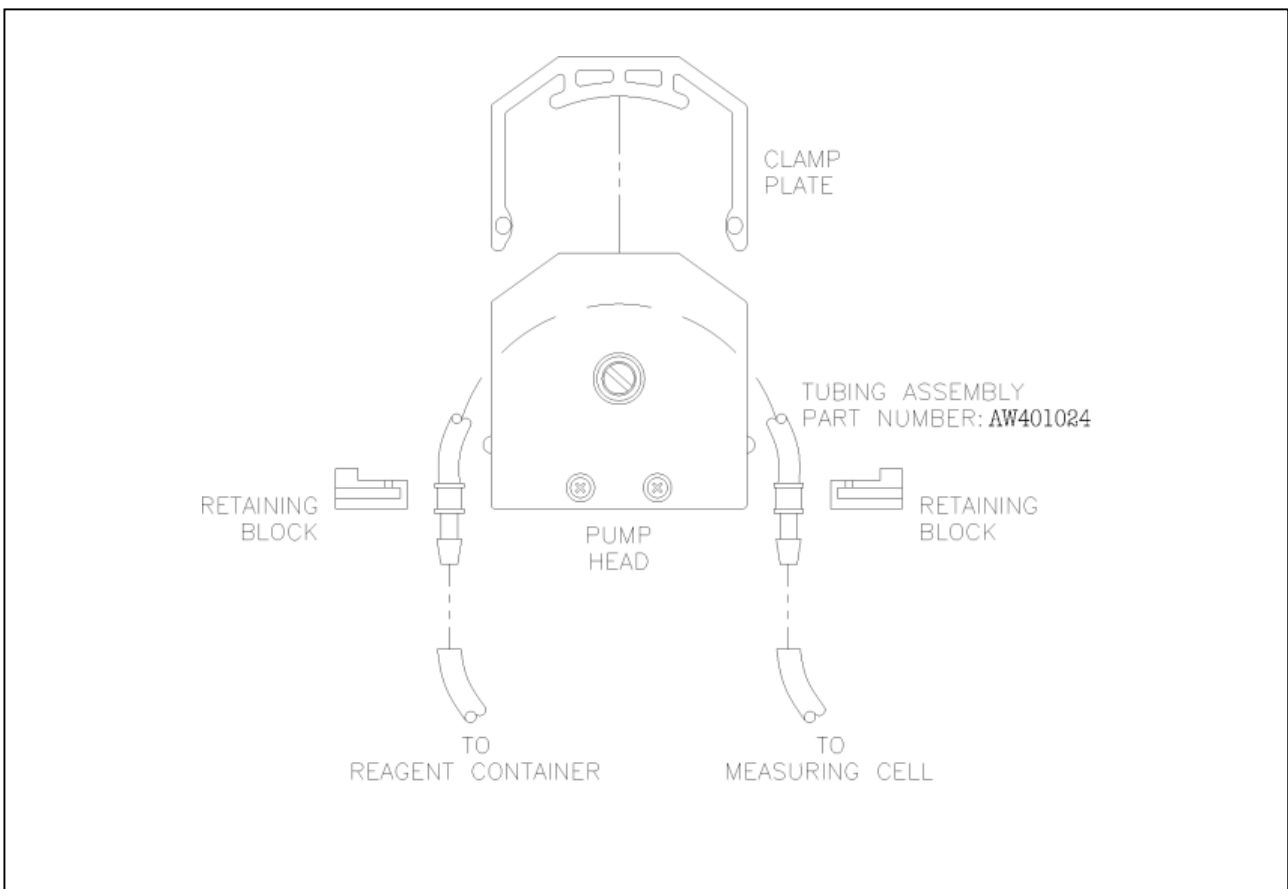

Fig. 10 Peristaltic pump, detail.

7.0 TROUBLESHOOTING

SYMPTOM	PROBABLE CAUSE	CHECK ACTION	CORRECTIVE ACT.
Unstable or erratic indication	Copper electrode corroded or dirty	Visual inspection	Clean or replace the copper electrode
	Too much or too small qty. of Corundum sand	Verify	Clean the electrodes cell and add the correct quantity of fresh Corundum sand
	Electrical contact not sufficient	Verify	Secure the connections
	Excessive air bubbles in the sample	Visual inspection in the drain hose	Eliminate the cause
	Reversed electrical connections to the electrodes	Verify	Make correct connections
	Faulty thermistor	Verify with tester	Replace thermistor assembly
	Broken or loosen wires	Verify	Replace or make secure connections
	Sample pressure or flow rate not sufficient	Verify	Correct the cause
	Faulty transmitter	Verify, according to Instruction Bulletin	Repair or send to ABB
Calibration required	Verify, according to Instruction Bulletin	Perform calibration	

8.0 PART LIST

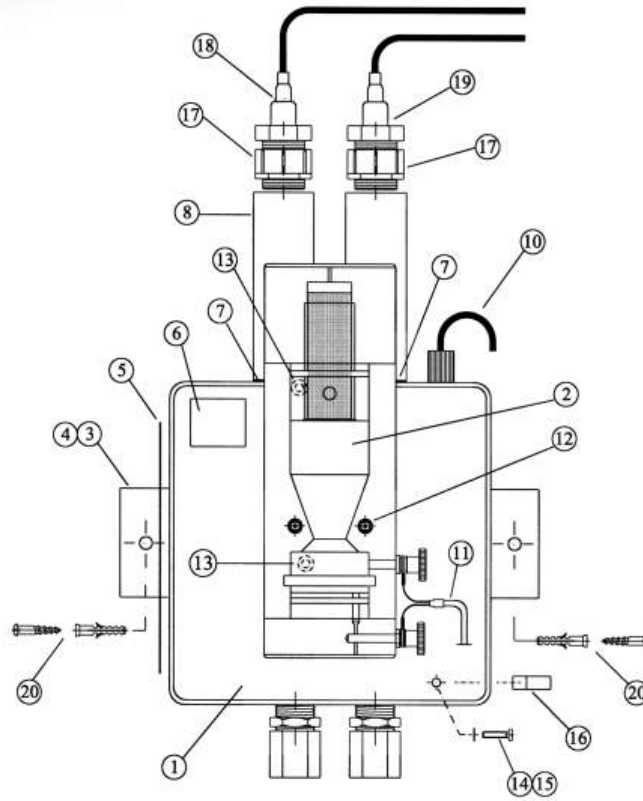

Fig. 11 AW400 Cell shown, with optional electrodes

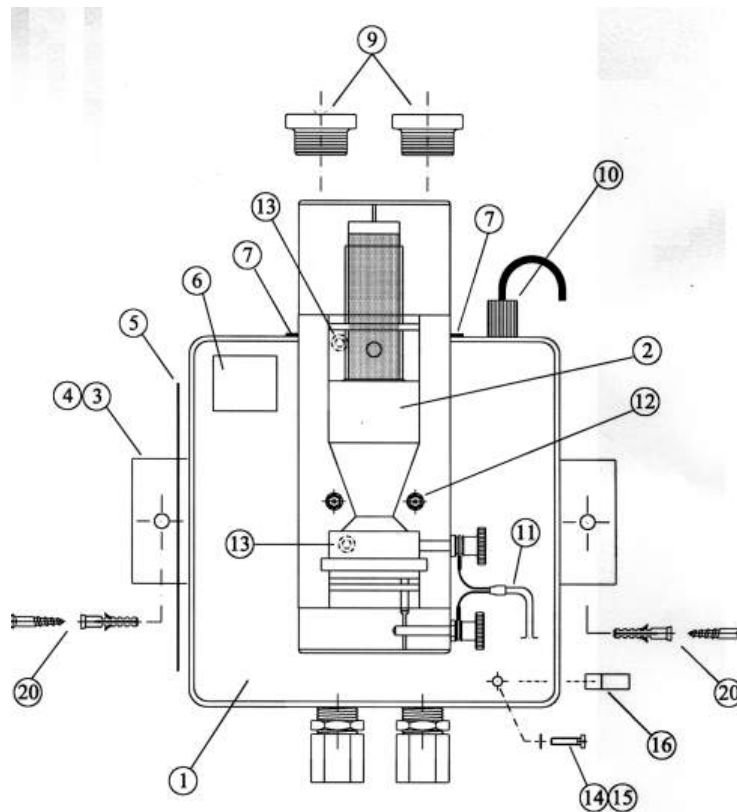

Fig. 12 AW400 Cell

Part List, AW400 Cell (See Fig. 11, and Fig. 12)

ITEM	DESCRIPTION	PART NUMBER
1	Regulator Assembly	AW401073
2	Cell Assembly	AW401074
3	Regulator Mounting Bracket	AW401075
4	M4 X 20 CSK Slot Screw	n/a
5	Identification & Serial No. Label	AW401076
6	ABB Branded Label	AW401035
7	O-Ring for Electrode Adaptor	AW401077
8	Electrode Adaptor Body	AW401078
9	PG13.5 Blanking Plug	AW401079
10	PT100 with Cable 3m (Standard)	AW401080
11	Cell Signal Cable 3m (Standard)	AW401081
12	M5 X 45 Socket Cap Head Screw	n/a
13	O-Ring for Cell Inlet/Outlet Ports	AW401082
14	M4 X 8 Cheese Head Screw	n/a
16	P-Clip (cable clip)	58-1002-B
17	Electrode Adaptor Gland	AW401083
18	pH Electrode	1413253
19	ORP Electrode	1184603
20	Cell Mounting Screws & Rawl Plugs	AW401084
21	Corundum Sand (100g)	AW401023
22	Sample Tube, 3/8" Polyethylene (per mtr.)	AW401085
1	Regulator Assembly	AW401073
2	Cell Assembly	AW401074

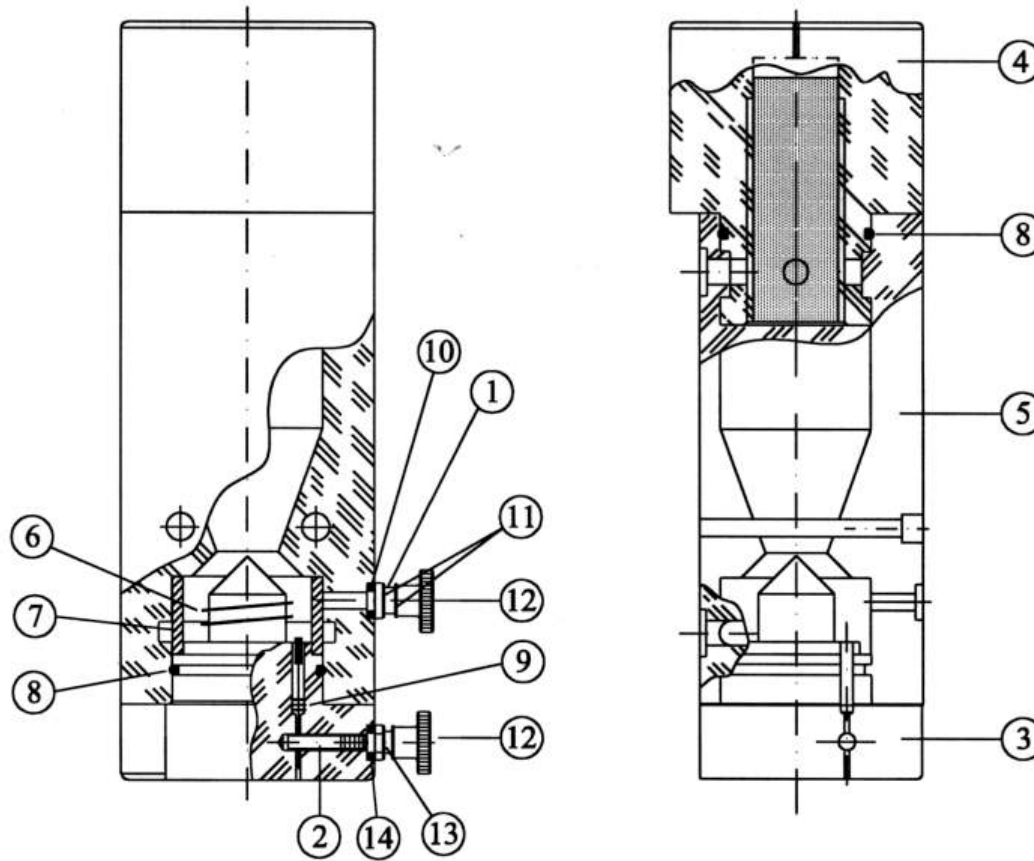

Fig. 13 AW400 Measuring cell

Part List, AW400 Measuring cell

ITEM	DESCRIPTION	PART NUMBER
1	Terminal Pin for Cu Electrode	AW401067
2	Terminal Pin for Gold Electrode	AW401068
3	Cell Electrode Head	AW401069
4	Cell Cover	AW401070
5	Cell Body	AW401071
6	Gold Electrode	AW401056
7	Copper Electrode	AW401057
8	O-Ring for Cell Head & Cover	AW401065
9	O-Ring for Gold Electrode	AW401064
10	O-Ring for Cu Electrode	AW401063
11	M3 Washer	37-0002-A
12	Knurled Nut	AW401072
13	M3 Nut	37-0001-A
14	M3 Spring Washer	n/a

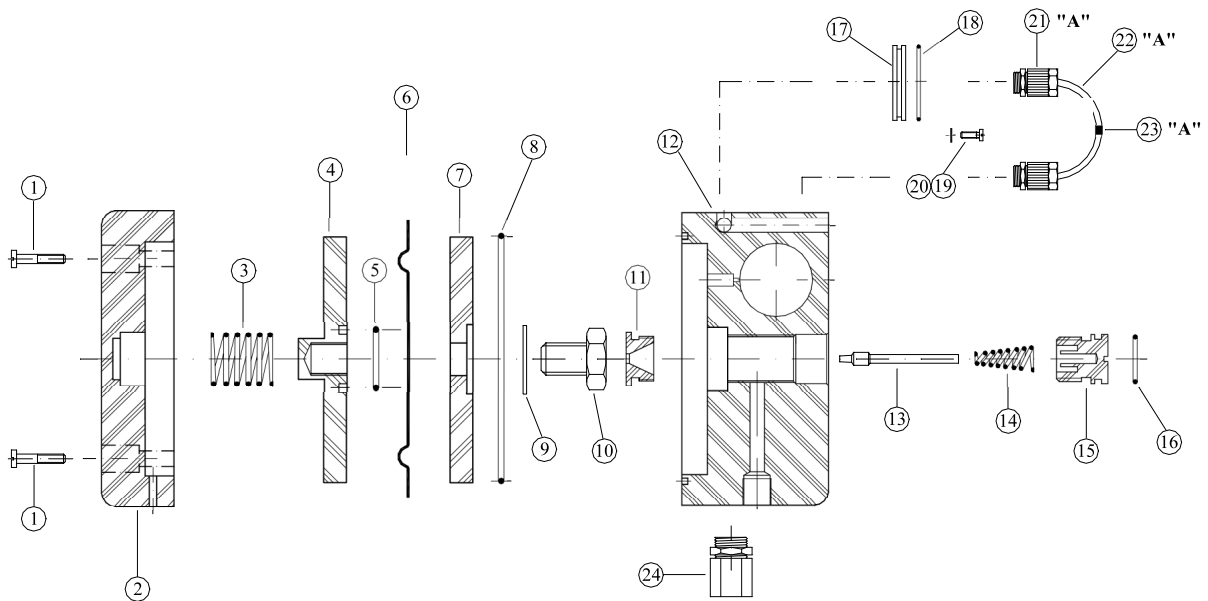

Fig. 14 Differential pressure regulator

Part List, AW400 Differential pressure regulator

ITEM	DESCRIPTION	PART NUMBER
1	M6 X 30 Cheese Head Screw	n/a
2	Regulator Back Body	AW401086
3	Regulator Parallel Spring	AW401087
4	Regulator Membrane Back Plate	AW401088
5	O-Ring for Membrane Back Plate to Membrane	AW401089
6	Regulator Membrane	AW401090
7	Regulator Membrane Front Plate	AW401091
8	O-Ring for Regulator Front Body to Membrane	AW401092
9	10mm Washer	AW401093
10	Membrane Plates Clamping Bolt	AW401094
11	Regulator Valve Seat	AW401095
12	Regulator Front Body	AW401096
13	Regulator Valve Pin Assembly	AW401097
14	Regulator Tapered Spring	AW401098
15	Regulation Screw	AW401099
16	O-Ring for Regulation Screw	AW401100
17	Plexiglas Disc	AW401101
18	O-Ring for Plexiglas Disc	AW401102
19	M4 Washer	37-0024-A
20	M4 X 8 Cheese Head Screw	n/a
21	1/8" X 6mm Tube Fitting	AW401103
22	Regulator Tube 6mm	AW401104
23	Orifice Insert for 6mm Tube	AW401105
24	1/4" NPT X 3/8" Tube Connector	AW401106

Products and customer support

Automation Systems

For the following industries:

- Chemical & Pharmaceutical
- Food & Beverage
- Manufacturing
- Metals and Minerals
- Oil, Gas & Petrochemical
- Pulp and Paper

Drives and Motors

- AC and DC Drives, AC and DC Machines, AC Motors to 1kV
- Drive Systems
- Force Measurement
- Servo Drives

Controllers & Recorders

- Single and Multi-loop Controllers
- Circular Chart and Strip Chart Recorders
- Paperless Recorders
- Process Indicators

Flexible Automation

- Industrial Robots and Robot Systems

Flow Measurement

- Electromagnetic Flowmeters
- Mass Flowmeters
- Turbine Flowmeters
- Wedge Flow Elements

Marine Systems & Turbochargers

- Electrical Systems
- Marine Equipment
- Offshore Retrofit and Refurbishment

Process Analytics

- Process Gas Analysis
- Systems Integration

Transmitters

- Pressure
- Temperature
- Level
- Interface Modules

Valves, Actuators and Positioners

- Control Valves
- Actuators
- Positioners

Water, Gas & Industrial Analytics Instrumentation

- pH, Conductivity and Dissolved Oxygen Transmitters and Sensors
- Ammonia, Nitrate, Phosphate, Silica, Sodium, Chloride, Fluoride, Dissolved Oxygen and Hydrazine Analyzers
- Zirconia Oxygen Analyzers, Katharometers, Hydrogen Purity and Purge-gas Monitors, Thermal Conductivity

Customer support

We provide a comprehensive after sales service via a Worldwide Service Organization. Contact one of the following offices for details on your nearest Service and Repair Centre.

UK

ABB Limited
Tel: +44 (0)1453 826661
Fax: +44 (0)1453 829671

USA

ABB Inc.
Tel: +1 215 674 6000
Fax: +1 215 674 7183

Client Warranty

Prior to installation, the equipment referred to in this manual must be stored in a clean, dry environment, in accordance with the Company's published specification. Periodic checks must be made on the equipment's condition. In the event of a failure under warranty, the following documentation must be provided as substantiation:

- A listing evidencing process operation and alarm logs at time of failure.
- Copies of all storage, installation, operating and maintenance records relating to the alleged faulty unit.

Contact us

ABB Limited

Process Automation

Oldends Lane
Stonehouse
Gloucestershire GL10 3TA
UK

Tel: +44 1453 826 661

Fax: +44 1453 829 671

ABB Inc.

Process Automation

125 E. County Line Road
Warminster
PA 18974
USA

Tel: +1 215 674 6000

Fax: +1 215 674 7183

www.abb.com

Note

We reserve the right to make technical changes or modify the contents of this document without prior notice. With regard to purchase orders, the agreed particulars shall prevail. ABB does not accept any responsibility whatsoever for potential errors or possible lack of information in this document.

We reserve all rights in this document and in the subject matter and illustrations contained therein. Any reproduction, disclosure to third parties or utilization of its contents in whole or in parts – is forbidden without prior written consent of ABB.

Copyright© 2011 ABB

All rights reserved

IM/AW/ASR Rev. E 06.2011