

COMMANDER SR250  
Chart Recorders

## Operating Guide

Modbus (RTU)  
Communications Option

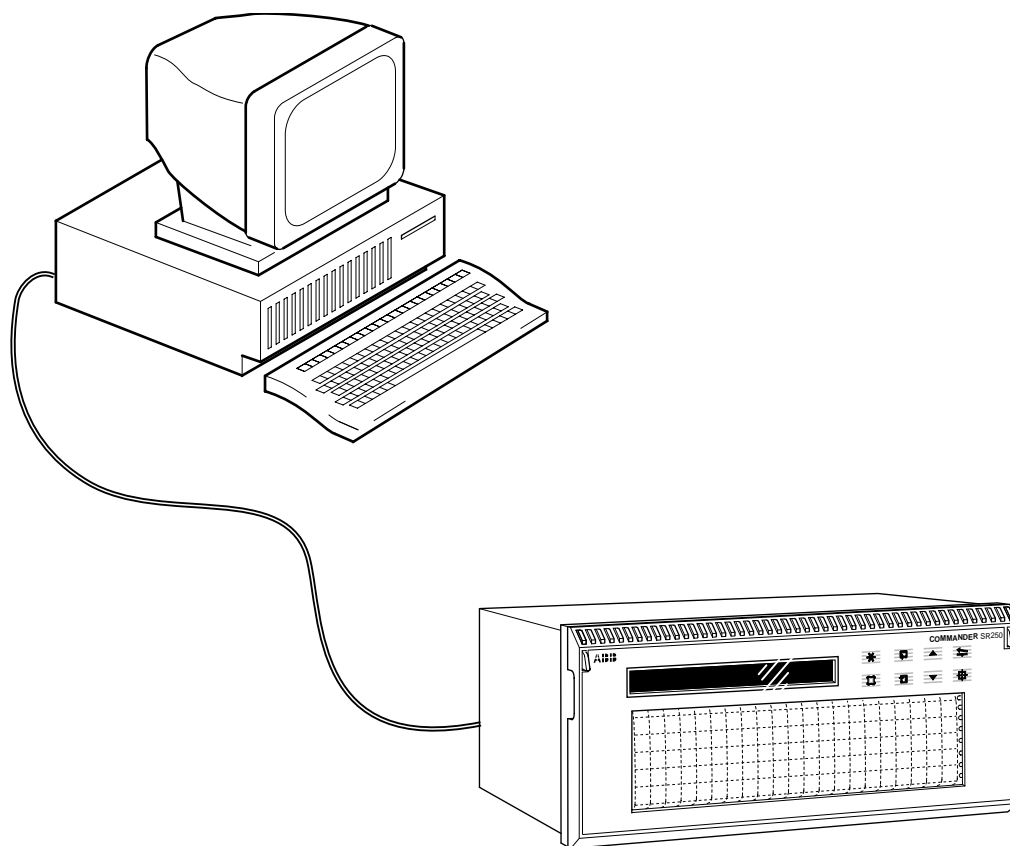

# ABB INSTRUMENTATION

## The Company

ABB Instrumentation is an established world force in the design and manufacture of instrumentation for industrial process control, flow measurement, gas and liquid analysis and environmental applications.

As a part of ABB, a world leader in process automation technology, we offer customers application expertise, service and support worldwide.

We are committed to teamwork, high quality manufacturing, advanced technology and unrivalled service and support.

The quality, accuracy and performance of the Company's products result from over 100 years experience, combined with a continuous program of innovative design and development to incorporate the latest technology.

The NAMAS Calibration Laboratory No. 0255 is just one of the ten flow calibration plants operated by the Company, and is indicative of ABB Instrumentation's dedication to quality and accuracy.

BS EN ISO 9001



St Neots, U.K. – Cert. No. Q5907  
Stonehouse, U.K. – Cert. No. FM 21106

EN 29001 (ISO 9001)



Lenno, Italy – Cert. No. 9/90A



Stonehouse, U.K.

## Use of Instructions



### Warning.

An instruction that draws attention to the risk of injury or death.



### Note.

Clarification of an instruction or additional information.



### Caution.

An instruction that draws attention to the risk of damage to the product, process or surroundings.



### Information.

Further reference for more detailed information or technical details.

Although **Warning** hazards are related to personal injury, and **Caution** hazards are associated with equipment or property damage, it must be understood that operation of damaged equipment could, under certain operational conditions, result in degraded process system performance leading to personal injury or death. Therefore, comply fully with all **Warning** and **Caution** notices.

Information in this manual is intended only to assist our customers in the efficient operation of our equipment. Use of this manual for any other purpose is specifically prohibited and its contents are not to be reproduced in full or part without prior approval of Technical Communications Department, ABB Instrumentation .

## Licensing, Trademarks and Copyrights

Modbus™ is a trademark of Modicon, Inc.

IBM™ and IBM PCAT are trademarks of International Business Machines Corp.

### Health and Safety

To ensure that our products are safe and without risk to health, the following points must be noted:

1. The relevant sections of these instructions must be read carefully before proceeding.
2. Warning labels on containers and packages must be observed.
3. Installation, operation, maintenance and servicing must only be carried out by suitably trained personnel and in accordance with the information given.
4. Normal safety precautions must be taken to avoid the possibility of an accident occurring when operating in conditions of high pressure and/or temperature.
5. Chemicals must be stored away from heat, protected from temperature extremes and powders kept dry. Normal safe handling procedures must be used.
6. When disposing of chemicals ensure that no two chemicals are mixed.

Safety advice concerning the use of the equipment described in this manual or any relevant hazard data sheets (where applicable) may be obtained from the Company address on the back cover, together with servicing and spares information.

# CONTENTS

Section	Page	Section	Page
<b>1 INTRODUCTION .....</b>	<b>2</b>	<b>6 EXCEPTION RESPONSES .....</b>	<b>12</b>
<b>2 ELECTRICAL INSTALLATION .....</b>	<b>2</b>	6.1 Examples .....	12
2.1 Selection of Serial Communication Adaptors for Personal Computers .....	2	<b>7 ADDRESSABLE PARAMETERS .....</b>	<b>13</b>
2.2 Recommended OPTO22 Boards .....	2	7.1 Coils .....	13
2.3 Pull-up and Pull-down Resistors .....	2	7.2 Holding Registers .....	17
2.4 Termination Resistors .....	3	<b>8 QUERY/RESPONSE DATA CODES .....</b>	<b>24</b>
2.5 RS485/422 Standard .....	3	8.1 Operator Message Character Code Conversion .....	24
2.6 Serial Connections .....	4		
<b>3 CONFIGURATION .....</b>	<b>5</b>		
3.1 Serial Communication Configuration Page .....	6		
<b>4 MODBUS PROTOCOL .....</b>	<b>7</b>		
4.1 Introduction to Modbus Protocol .....	7		
4.2 Modbus Function Codes .....	7		
<b>5 MODBUS FUNCTIONS .....</b>	<b>8</b>		
5.1 Read Coil Status – Function Code 01 .....	8		
5.1.1 Read Coil Status Query .....	8		
5.1.2 Read Coil Status Response .....	8		
5.2 Read Holding Register – Function Code 03 .....	8		
5.2.1 Read Holding Register Query .....	8		
5.2.2 Read Holding Register Response .....	9		
5.3 Force Single Coil – Function Code 05 .....	9		
5.3.1 Force Single Coil Query .....	9		
5.3.2 Force Single Coil Response .....	9		
5.4 Preset Single Register – Function Code 06 .....	10		
5.4.1 Preset Single Register Query .....	10		
5.4.2 Preset Single Register Response .....	10		
5.5 Loopback Diagnostic Test – Function Code 08 .....	10		
5.5.1 Loopback Diagnostic Test Query .....	10		
5.5.2 Loopback Diagnostic Test Response .....	10		
5.6 Force Multiple Coils – Function Code 15 .....	11		
5.6.1 Force Multiple Coils Query .....	11		
5.6.2 Force Multiple Coils Response .....	11		
5.7 Preset Multiple Registers – Function Code 16 .....	11		
5.7.1 Preset Multiple Registers Query .....	11		
5.7.2 Preset Multiple Registers Response .....	11		



### Information.

Modbus protocol is the standard for communications from PLC to system and digital controller to PC/PLC. It supports open communications and provides more information with a greater degree of interchangeability and connectability for all process control and recording devices.

# 1 INTRODUCTION

**i** **Information.**

- The Advanced Process Recorder and Multipoint Chart Recorder can be extended by the addition of a serial data communication option designed for use with SCADA systems.
- RS422/485 Communication Standard.
- Modbus RTU protocol – for master (host computer) to slave (Advanced Process Recorder or Multipoint Chart Recorder) system.
- Isolated (500V) from rest of instrument.
- 2-wire and 4-wire communication supported.
- Baud rate – from 1200 to 9600.
- Parity-checking – odd, even or none.

# 2 ELECTRICAL INSTALLATION

## 2.1 Selection of Serial Communication Adaptors for Personal Computers

**i** **Information.**

- An RS422/485 communication board is required in the host PC.
- Observe the limitations outlined in the *User Guide* – the maximum serial data transmission line length for both RS422 and RS485 systems is 1200m.

An RS422/485 communications adaptor is required for serial links. It is strongly recommended that the card used has galvanic isolation to protect the computer from lightning damage and increase immunity from noise pick-up.

## 2.2 Recommended OPTO22 Boards

The following OPTO22 boards are recommended for use with the Advanced Process and Multipoint Chart Recorders:

Part No.	Computer Type
AC24 AT	AT Bus IBM PC compatible
AC34	Microchannel IBM PC.

## 2.3 Pull-up and Pull-down Resistors – Fig. 2.1

To prevent false triggering of the slave (Advanced Process Recorder/Multipoint Chart Recorder) by the presence of noise when the master (host computer) is inactive, 1.8kΩ pull-up and pull-down resistors must be fitted to the RS422/485 adaptor card – see Fig. 2.1 .

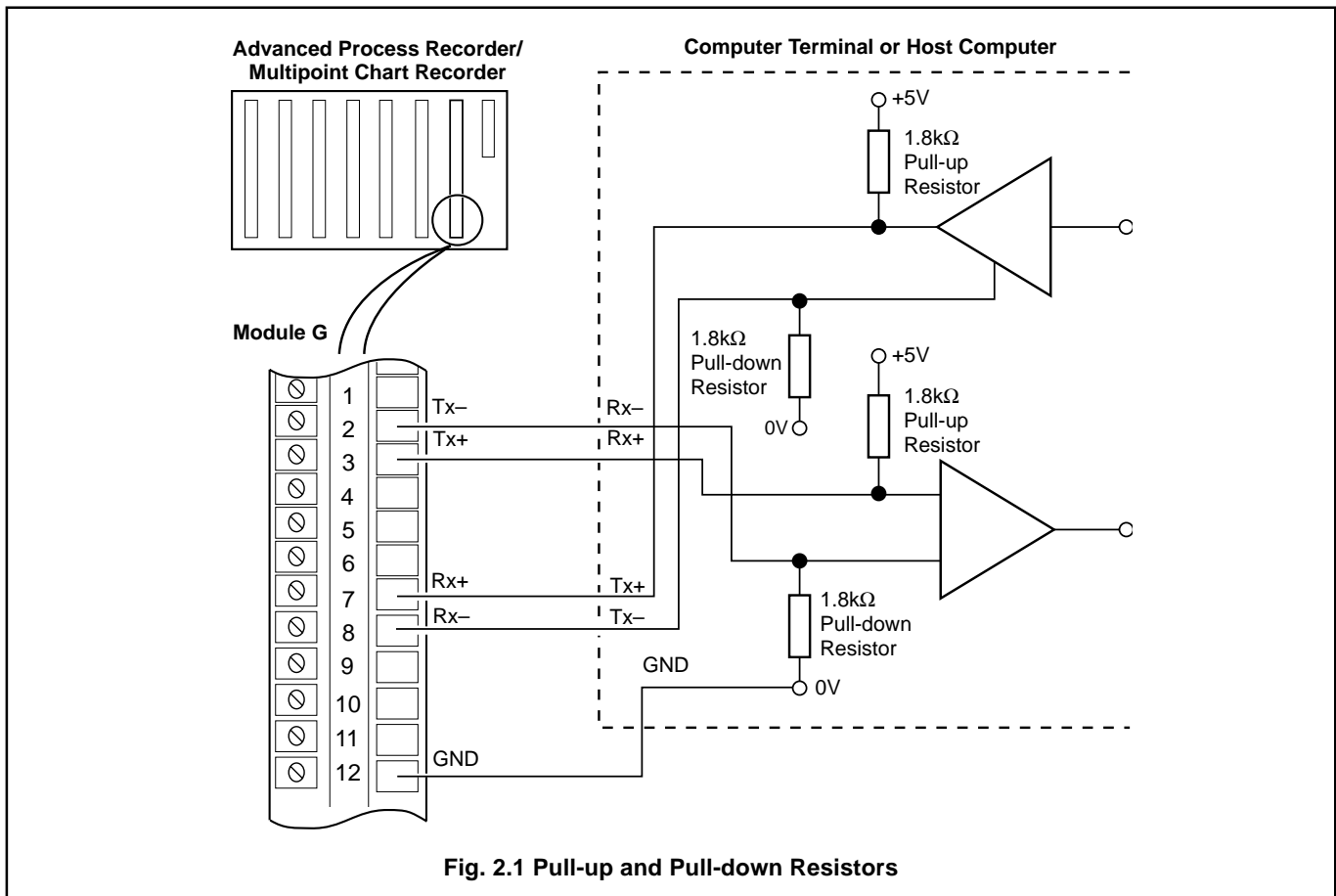

**Fig. 2.1 Pull-up and Pull-down Resistors**

**2.4 Termination Resistors – Fig. 2.2**

Under normal operating conditions the slave termination resistors are linked-out. For long transmission lines, termination resistors are required on the last slave in the chain and the host computer/computer terminal – see Fig. 2.2A. The slaves' termination resistors are linked-in using plug-in link (PL2) on the serial module – see Fig. 2.2B.

**2.5 RS485/422 Standard**

The RS485 standard allows connection of up to 32 slaves to any single driver (computer terminal or host computer); the RS422 standard allows connection of up to ten slaves. However, these numbers can be increased if the driver's serial port permits.

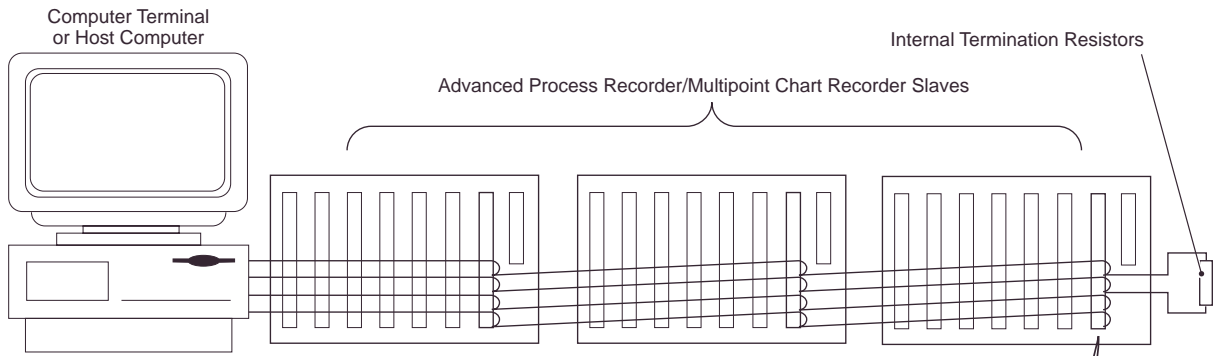

**A – Schematic Diagram**

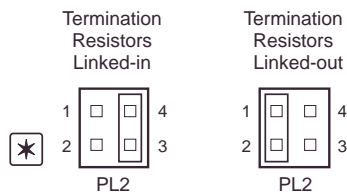
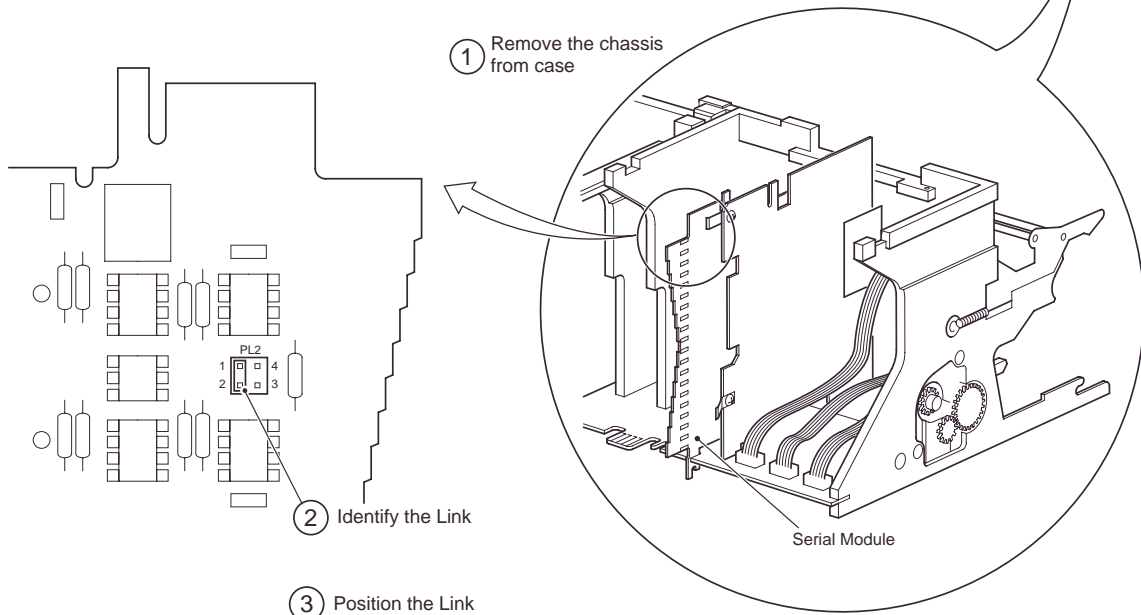

**B – Termination Link Positions**

**\* Note.** For long transmission lines, the internal termination resistors on the last slave in the chain must be linked-in.

**Fig. 2.2 Slave Termination Resistors**

## ...2 ELECTRICAL INSTALLATION

### 2.6 Serial Connections – Fig. 2.3

**i** Information.

- Up to **10 slaves** can be connected to a single **RS422** adaptor card on a PC.
- Up to **32 slaves** can be connected to a single **RS485** adaptor card on a PC.
- The maximum serial data transmission line length for both **RS422** and **RS485** systems is 1200m.

All connections, apart from those for serial data communication, are made as shown in Section 4 of the *User Guide*.

Make serial data connections as shown in Fig. 2.3. The type of cable used is dependent on the cable length:

**Up to 6m** – standard screened or twisted pair cable,

**Up to 300m** – twin twisted pair with overall foil screen and an integral drain wire, e.g. Belden 9502 or equivalent,

**Up to 1200m** – twin twisted pair with separate foil screens and integral drain wires for each pair, e.g. Belden 9729 or equivalent.

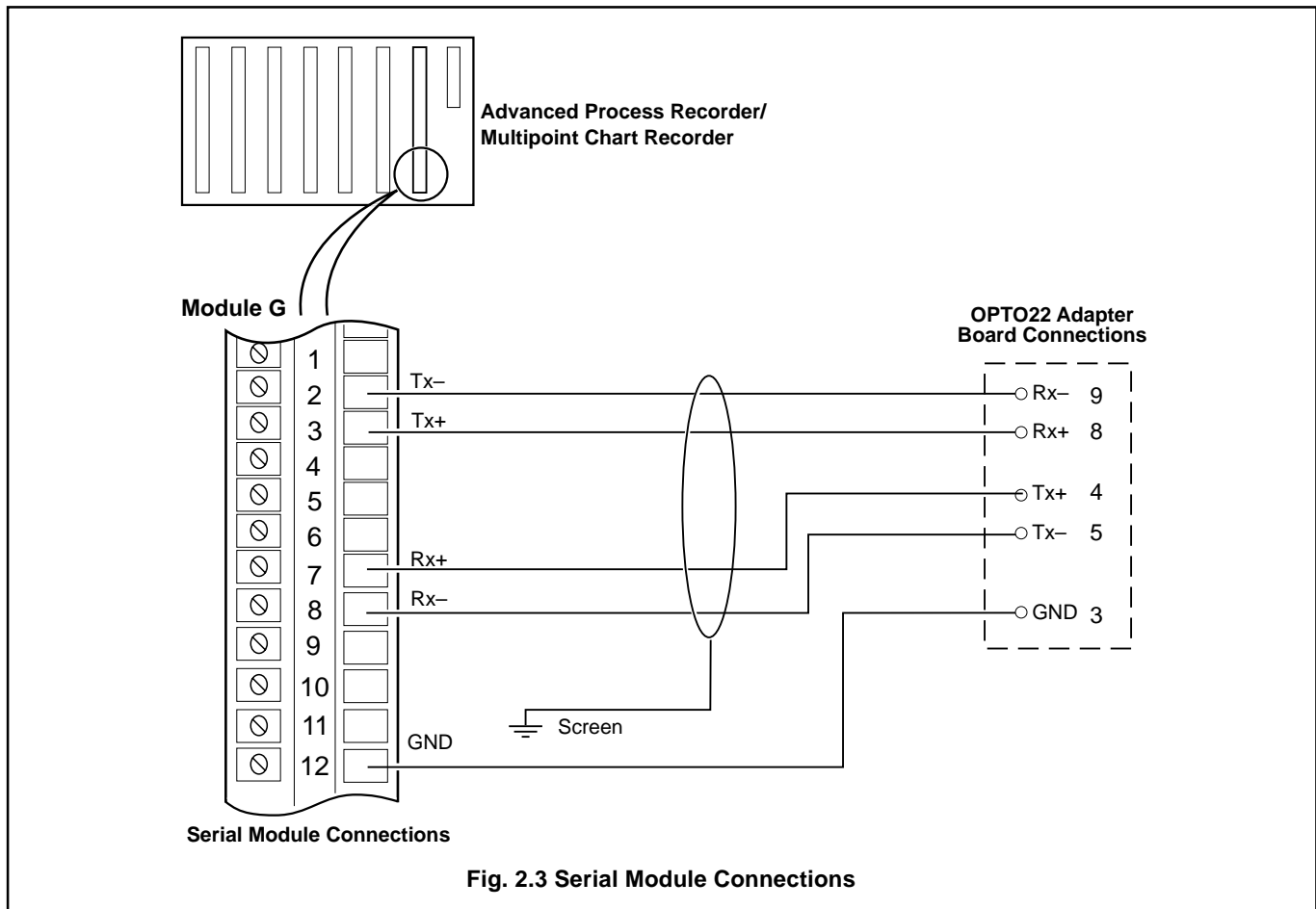
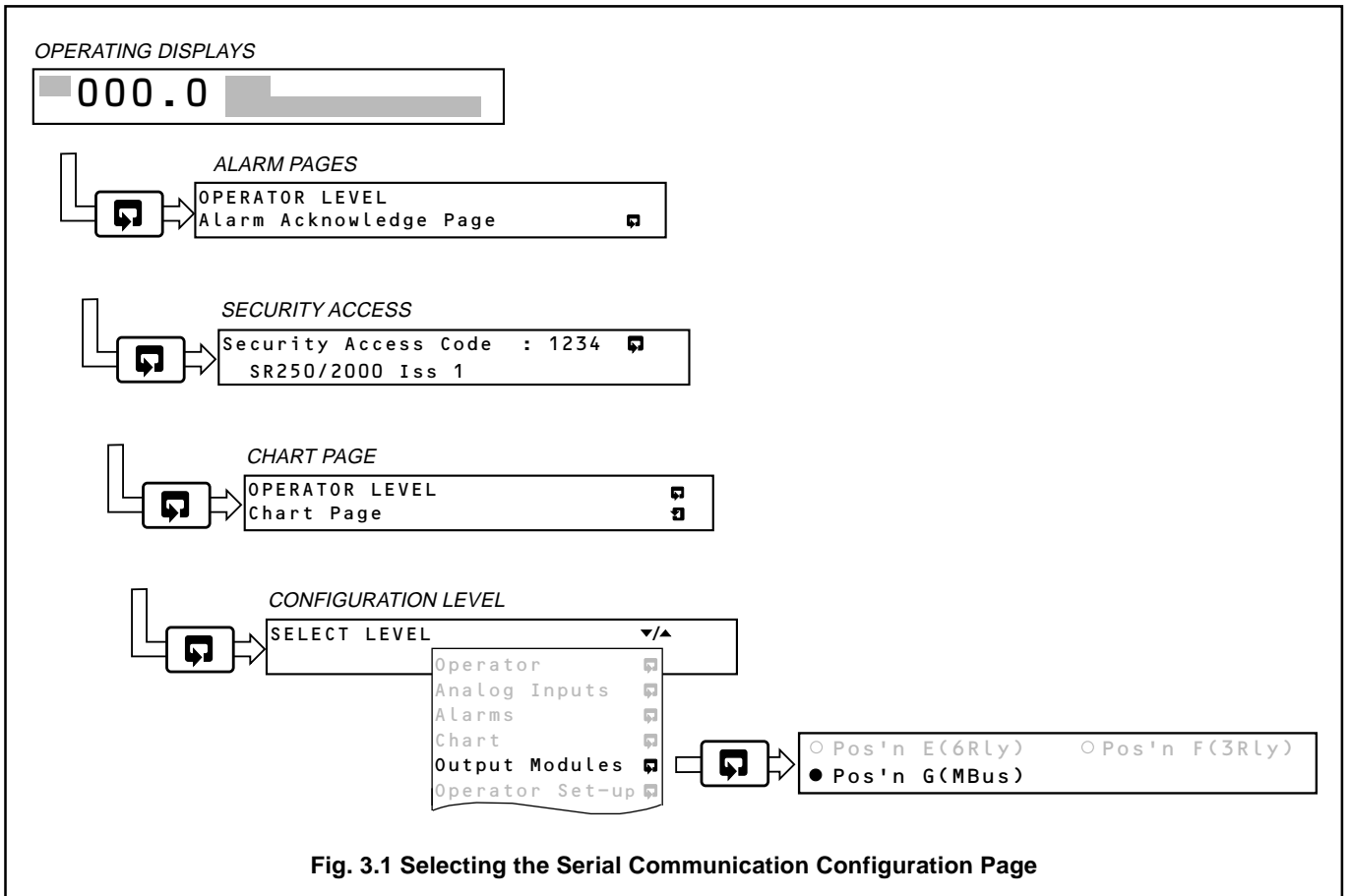

**Fig. 2.3 Serial Module Connections**

Advanced Process Recorder/Multipoint Chart Recorder Serial Module		OPTO22 Board Pin Identification	
Terminal No.	Connections	Part Number AC24 AT & AC34	Connections
2	TX-	9	RX-
3	TX+	8	RX+
7	RX+	4	TX+
8	RX-	5	TX-
12	GND	3	GND

**Table 2.1 Terminal and Pin Identification**

### 3 CONFIGURATION



## ...3 CONFIGURATION

### 3.1 Serial Communication Configuration Page



#### Information.

- Programmable Modbus protocol.
- Programmable baud rate (1200 to 9600 baud).
- None, odd or even parity.

The general programming procedure is as detailed in the *User Guide*. The instrument is despatched with Company Standard Settings.

○ Pos'n E(6Rly)    ○ Pos'n F(Hybd)  
● Pos'n G(MBus)

Modbus Identity:01    Baud:9600  
Parity :None    Type:4 Wire

Modbus Identity:99    Baud:9600  
Parity :None    Type:4 Wire

Modbus Identity:01    Baud:9600  
Parity :None    Type:4 Wire

Modbus Identity:01    Baud:9600  
Parity :None    Type:4 Wire

Modbus Identity:01    Baud:9600  
Parity :None    Type:4 Wire

Advance to the **Output Modules Level** and select the **Serial Communication Configuration Page** – see Fig. 3.1.

#### Identity

Assign the recorder an identification number (01 to 99). The identification number allows the host computer to address recorders individually when more than one recorder is connected to the same communications link.

#### Transmission (Baud) Rate

Select the transmission rate required (1200 slowest, 9600 fastest).

#### Parity

Select the appropriate parity to match the computer terminal or host computer.

#### Type

Select the number of transmission wires used, 2 or 4.

Return to **Serial Communication Configuration** frame.

## 4 MODBUS PROTOCOL



### Information.

- The Advanced Process Recorder and Multipoint Chart Recorder operate as Modbus, Remote Terminal Unit (RTU) slaves.
- Parity checking – used to detect transmission errors in individual characters.
- Cyclic redundancy checking – used to detect errors in the master messages and slave responses.

### 4.1 Introduction to Modbus Protocol

Modbus communication is based on a master/slave arrangement. The master sends a message to one slave at a time and waits for a reply.

A slave cannot accept a new message until the existing message is processed and a reply sent to the master (maximum response time 125 milliseconds). The slave monitors the elapsed time between receipt of characters. If the elapsed time exceeds 3½ character times, the slave assumes the next character received is the start of a new message.

To allow the master to differentiate between slaves in a system, each slave is given a unique identity address (between 1 and 99).

A broadcast address (address zero) can be used to access all slave devices with one command. This is limited to write messages only and there is no slave acknowledgment.



**Note.** Modbus RTU requires 1 start bit, 8 data bits, 1 parity bit (optional) and 1 or 2 stop bits.

### 4.2 Modbus Function Codes

The function code field instructs the addressed slaves which function to perform. Table 4.1 shows the function codes and describes the action they initiate.

Modbus Function Code	Modbus Message Name	Advanced Process Recorder/Multipoint Chart Recorder Definition
01	Read Coil Status	Read up to 32 consecutive discrete (Boolean) points (coils) from a specific starting point. The instrument returns zeros for points which do not contain defined data.
03	Read Holding Registers	Read up to 8 consecutive holding registers from a specific starting register. The instrument returns zeros from registers which do not contain defined data.
05	Force Single Coil	Write one discrete (Boolean) point (coil). The instrument returns an exception response if the point is not currently writeable.
06	Preset Single Register	Write one holding register. The instrument returns an exception response if the register is not currently writeable. This function code also applies any currently applicable limits to the value before storage in the database.
08	Loopback Diagnostic Test	Data diagnostic code 0000 returns query data. Other diagnostic codes return exception responses
15	Force Multiple Coils	Write up to 32 consecutive discrete (boolean) points (coils) from a specific starting point. The instrument returns an exception response if any of the coils are not currently writeable, but still carries out all the writes which are valid. <b>Any coil changes resulting from the use of this command are NOT saved in the non-volatile memory.</b>
16	Preset Multiple Registers	Write up to 8 consecutive holding registers from a specified starting register. The instrument returns an exception response if any of the registers are not currently writeable, but still carries out all the writes which are valid. This function code also applies any currently applicable limits to the value before storage in the database. <b>Any register changes resulting from the use of this command are NOT saved in the non-volatile memory.</b>

Table 4.1 Modbus Function Codes

## 5 MODBUS FUNCTIONS

This section shows typical examples of Modbus function codes 01, 03, 05, 06, 08, 15 and 16.

### 5.1 Read Coil Status – Function Code 01

#### 5.1.1 Read Coil Status Query

This function allows the user to obtain the ON/OFF status of logic coils within the addressed slave only. Broadcast mode is not supported with this function code. In addition to the slave address and function fields, the message requires the initial coil offset address to be read (starting address) and the number of locations to be interrogated.

★ **Note.** The coil offset address is the coil number minus one, e.g. to start at coil 1 the data start value must be set to 0 (0H).

**Example** – a read coil status request to read 12 coils from slave (01) starting at coil 1 (module A, I/P 1 failure status) is shown below.

Address	Function	Coil Start Offset High	Coil Start Offset Low	Number of Coils High	Number of Coils Low	Error Check Field	(CRC-16)
01	01	00	00	00	0C	3C	0F

#### 5.1.2 Read Coil Status Response

The data is packed one bit for each coil (1 = active, 0 = inactive). The response includes the slave address, function code, quantity of data characters, the data characters and error checking. The low order bit of the first character contains the first addressed coil and the remainder follow. For coil quantities that are not even multiples of eight, the last characters are filled in with zeros at high order end.

**Example** – the response to the read coil status query shows the following:

No module A inputs (1 to 6) show failed  
 No module B inputs (1 to 6) show failed

Address	Function	Byte Count	Data Coil Status 1 to 8	Data Coil Status 9 to 12	Error Check Field	(CRC-16)
01	01	02	00	00	B9	FC

### 5.2 Read Holding Register – Function Code 03

#### 5.2.1 Read Holding Register Query

The Read holding registers allow the user to obtain the binary contents of holding registers in the addressed slave.

★ **Note.** The data start register must contain the offset address of the first register to be accessed, e.g. to start at register 95 the data start register must be set to 94 (5EH).

Broadcast mode is not allowed.

**Example** – a read holding register request to read 6 holding registers from slave (01) starting at holding address 95 (alarm A trip point) is shown below.

Address	Function	Register Start Offset High	Register Start Offset Low	Data Number of Registers High	Data Number of Registers Low	Error Check Field	(CRC-16)
01	03	00	5E	00	06	A4	1A

**5.2.2 Read Holding Register Response**

The addressed slave responds with its address and function code, followed by the information field. The information field contains 1 byte describing the quantity of data bytes to be returned. The contents of each register requested is two bytes, the first byte contains the high order bits and the second the low order bits.

**Example** – the response to the read holding register query shows the following:

- Alarm Pa A trip point – 150
- Alarm Pa B trip point – 50
- Alarm Pa C trip point – 100
- Alarm Pa D trip point – 400
- Alarm Pa E trip point – 0
- Alarm Pa F trip point – 0.

Address	Function	Byte Count	Holding Register 95		Holding Register 96		Holding Register 97		Holding Register 98		Holding Register 99		Holding Register 100		Error Check Field (CRC16)	
			High	Low	High	Low	High	Low	High	Low	High	Low	High	Low		
01	03	0C	00	96	00	32	00	64	01	90	00	00	00	00	D9	91

**5.3 Force Single Coil – Function Code 05**

**5.3.1 Force Single Coil Query**

This message forces a single coil into the active or inactive state. The data value 65,280 (FF00 HEX) renders the coil active and the value zero renders the coil inactive. All other values are illegal and do not affect the coil.

**\* Note.** To write to a coil the coil offset address must be used, e.g. to write to coil 171, the coil address 170 (AAH) is transmitted.

The use of slave address zero (broadcast mode) forces all attached slaves to modify the desired coil.

**Example** – a force single coil request to set coil address 171 (serial digital input) active in slave 01 is shown below.

Address	Function	Coil Offset High	Coil Offset Low	Data Value High	Data Value Low	Error Check Field (CRC-16)
01	05	00	AA	FF	00	AC 1A

**5.3.2 Force Single Coil Response**

The response is confirmation of the query after the coil state has been altered.

**Example:**

Address	Function	Coil Offset High	Coil Offset Low	Data Value High	Data Value Low	Error Check Field (CRC-16)
01	05	00	AA	FF	00	AC 1A

## ...5 MODBUS FUNCTIONS

### 5.4 Preset Single Register – Function Code 06

#### 5.4.1 Preset Single Register Query

The preset single register allows the user to modify the contents of a holding register.

**\*** **Note.** To write to a register, the register's offset address must be used, e.g. to write to register 95, the offset address 94 (5EH) is transmitted.

The use of slave address zero (broadcast mode) forces all attached slaves to modify the desired register.

**Example** – a preset single register request to write the value 500 to holding register address 95 (Alarm PaA trip point) in slave 01 is shown below.

Address	Function	Register Offset High	Register Offset Low	Data Value High	Data Value Low	Error Check Field	(CRC-16)
01	06	00	5E	01	F4	E8	0F

#### 5.4.2 Preset Single Register Response

The normal response to a preset single register request is to retransmit the query message after the register has been altered.

**Example:**

Address	Function	Register Offset High	Register Offset Low	Data Value High	Data Value Low	Error Check Field	(CRC-16)
01	06	00	5E	01	F4	E8	0F

### 5.5 Loopback Diagnostic Test – Function Code 08

#### 5.5.1 Loopback Diagnostic Test Query

The purpose of the loopback diagnostic test is to test the Modbus system, it does not affect the content of the controller. Variations in the response may indicate faults in the Modbus system. The information field contains 2 bytes for the designation of the diagnostic code followed by 2 bytes to designate the action to be taken.

**Example** – a loopback test query of slave 01 is shown below.

Address	Function	Data Diagnostic Code High	Data Diagnostic Code Low	Data *	Data *	Error Check Field	(CRC-16)
01	08	00	00	A5	37	DA	8D

\* These are considered to be the information fields for diagnostic mode.

#### 5.5.2 Loopback Diagnostic Test Response

The response always echoes the query. Only diagnostic code 0 (bytes 3 and 4) can be used.

**Example:**

Address	Function	Data Diagnostic Code High	Data Diagnostic Code Low	Data	Data	Error Check Field	(CRC-16)
01	08	00	00	A5	37	DA	8D

**5.6 Force Multiple Coils – Function Code 15**

**5.6.1 Force Multiple Coils Query**

Coils existing within the recorder can have their contents changed by this message (a maximum of 32 coils). When used with slave address zero (broadcast mode) all slave controllers load the selected coils with the contents specified.



**Note.** To write to multiple coils, the initial coil offset address must be used, e.g. to write to coil 141 onwards, the offset address 140 (8CH) is transmitted.

**Example** – a preset multiple coils request to set all coil addresses 141 through 152 (PaA to PaM alarm acknowledge) active, in slave 01 is shown below.

Address	Function	Coil Start Offset High	Coil Start Offset Low	Number of Coils	Byte Count	Coil Status 141 to 148	Coil Status 149 to 152	Error Check Field (CRC-16)	
01	0F	00	8C	00 0C	02	FF	0F	FB	48

**5.6.2 Force Multiple Coils Response**

The response confirms slave identification, function code, starting coil address and quantity only.

**Example:**

Address	Function	Coil Start Offset High	Coil Start Offset Low	Number of Coils		Error Check Field (CRC-16)	
01	0F	00	8C	00	0C	94	25

**5.7 Preset Multiple Registers – Function Code 16**

**5.7.1 Preset Multiple Registers Query**

Holding registers (up to a maximum of 8) existing within the controller can have their contents changed by this message. When used with slave address zero (broadcast mode) all slave controllers load the selected registers with the contents specified.



**Note.** To write to multiple registers, the initial register offset address must be used, e.g. to write to register 85 onwards, the offset address 84 is transmitted.

**Example** – a preset multiple registers request to write the value 10 to the register address 85 (chart speed 1) and the value 100 to the register address 86 (chart speed 2) in slave 01 is shown below.

Address	Function	Register Start Offset High	Register Start Offset Low	Number of Registers	Byte Count	Holding Register 85 High	Holding Register 85 Low	Holding Register 86 High	Holding Register 86 Low	Error Check Field (CRC-16)	
01	10	00	54	00 02	04	00	0A	00	64	D6	89

**5.7.2 Preset Multiple Registers Response**

The response confirms slave identification, function code, starting register address and quantity only.

**Example:**

Address	Function	Register Start Offset High	Register Start Offset Low	Number of Registers		Error Check Field (CRC-16)	
01	10	00	54	00	02	00	18

## 6 EXCEPTION RESPONSES

The exception response codes sent by the slave are shown in Table 6.1. When a slave detects one of these errors, it sends a response message to the master consisting of slave address, function code, error code and error check fields.

Exception Response Code	Exception Response Name	Exception Response Definition
01	Illegal Function	The message function received is not an allowable action for the instrument.
02	Illegal Data Address	The address reference in the data field is not an allowable address for the instrument.
03	Illegal Data Value	The value referenced in the data field is not allowable in the addressed slave location.
07	Negative Acknowledgment	Received message error.
08	Memory Parity Error	Parity check indicates an error in one or more of the characters received.

**Table 6.1 Exception Response Codes**

### 6.1 Examples

A read register request to read holding register address 291 of slave 01 (undefined address for slave, beyond address limit) is shown below.

Slave Address	Function	Register Start Offset High	Register Start Offset Low	Number of Registers High	Number of Registers Low	Error Check Field (CRC-16)
01	03	01	22	00	06	64 E3

The response is an exception response citing 'illegal data address'. To indicate that the response is a notification of an error, the most significant bit of the function code is set to 1.

Slave Address	Function	Exception Code	Error Check Field (CRC-16)
01	83	02	C0 F1

## 7 ADDRESSABLE PARAMETERS

### 7.1 Coils

Coil Number	Read/Write	Description	Response Entry
		<b>Input Fail States</b>	
001	R	Analog Input A1	{ 0 = Inactive 1 = Active
002	R	Analog Input A2	
003	R	Analog Input A3	
004	R	Analog Input A4	
005	R	Analog Input A5	
006	R	Analog Input A6	
007	R	Analog Input B1	
008	R	Analog Input B2	
009	R	Analog Input B3	
010	R	Analog Input B4	
011	R	Analog Input B5	
012	R	Analog Input B6	
013	R	Analog Input C1 *	
014	R	Analog Input C2 *	
015	R	Analog Input C3 *	
016	R	Analog Input C4 *	
017	R	Analog Input C5 *	
018	R	Analog Input C6 *	
019	R	Analog Input D1 *	
020	R	Analog Input D2 *	
021	R	Analog Input D3 *	
022	R	Analog Input D4 *	
023	R	Analog Input D5 *	
024	R	Analog Input D6 *	
		<b>Process Alarm Status</b>	
040	R	Pa A	
041	R	Pa B	
042	R	Pa C	
043	R	Pa D	
044	R	Pa E	
045	R	Pa F	
046	R	Pa G	
047	R	Pa H	
048	R	Pa J	
049	R	Pa K	
050	R	Pa L	
051	R	Pa M	
052	R	Pa N	
053	R	Pa P	
054	R	Pa Q	
055	R	Pa R	
056	R	Pa S	
057	R	Pa T	
058	R	Pa U	
059	R	Pa V	
060	R	Pa W	
061	R	Pa X	
062	R	Pa Y	
063	R	Pa Z	

\* SR250A only

## ...7 ADDRESSABLE PARAMETERS

### ...7.1 Coils

Coil Number	Read/Write	Description	Response Entry	
		<b>Digital Input State</b>		
065	R	Digital Input DE1	} 0 = Inactive 1 = Active	
066	R	Digital Input DE2		
067	R	Digital Input DE3		
068	R	Digital Input DE4		
069	R	Digital Input DE5		
070	R	Digital Input DE6		
075	R	Digital Input DF1		
076	R	Digital Input DF2		
077	R	Digital Input DF3		
078	R	Digital Input DF4		
079	R	Digital Input DF5		
080	R	Digital Input DF6		
095	R	Module A Digital Input DA1		
096	R	Module B Digital Input DB1		
097	R	Module C Digital Input DC1		
098	R	Module D Digital Input DD1		
		<b>Digital Output State</b>		
105	R	Digital Output DE1		
106	R	Digital Output DE2		
107	R	Digital Output DE3		
108	R	Digital Output DE4		
109	R	Digital Output DE5		
110	R	Digital Output DE6		
115	R	Digital Output DF1		
116	R	Digital Output DF2		
117	R	Digital Output DF3		
118	R	Digital Output DF4		
119	R	Digital Output DF5		
120	R	Digital Output DF6		

...7.1 Coils

Coil Number	Read/Write	Description	Response Entry
<b>Alarm Acknowledge State</b>			0 = Acknowledged or inactive 1 = Active and unacknowledged
140	R/W	Global Alarm Acknowledge	
141	R/W	Pa A Acknowledge	
142	R/W	Pa B Acknowledge	
143	R/W	Pa C Acknowledge	
144	R/W	Pa D Acknowledge	
145	R/W	Pa E Acknowledge	
146	R/W	Pa F Acknowledge	
147	R/W	Pa G Acknowledge	
148	R/W	Pa H Acknowledge	
149	R/W	Pa J Acknowledge	
150	R/W	Pa K Acknowledge	
151	R/W	Pa L Acknowledge	
152	R/W	Pa M Acknowledge	
153	R/W	Pa N Acknowledge	
154	R/W	Pa P Acknowledge	
155	R/W	Pa Q Acknowledge	
156	R/W	Pa R Acknowledge	
157	R/W	Pa S Acknowledge	
158	R/W	Pa T Acknowledge	
159	R/W	Pa U Acknowledge	
160	R/W	Pa V Acknowledge	
161	R/W	Pa W Acknowledge	
162	R/W	Pa X Acknowledge	
163	R/W	Pa Y Acknowledge	
164	R/W	Pa Z Acknowledge	
<b>Modbus Digital Signals</b>			Activated only by Serial Comms. 0 = Inactive 1 = Active
171	R/W	Modbus Digital Input – MODBUS	
172	R/W	Modbus Digital Input 01 – MDB-01	
173	R/W	Modbus Digital Input 02 – MDB-02	
174	R/W	Modbus Digital Input 03 – MDB-03	
175	R/W	Modbus Digital Input 04 – MDB-04	
176	R/W	Modbus Digital Input 05 – MDB-05	
177	R/W	Modbus Digital Input 06 – MDB-06	
178	R/W	Modbus Digital Input 07 – MDB-07	
179	R/W	Modbus Digital Input 08 – MDB-08	
180	R/W	Modbus Digital Input 09 – MDB-09	
181	R/W	Modbus Digital Input 10 – MDB-10	
182	R/W	Modbus Digital Input 11 – MDB-11	
183	R/W	Modbus Digital Input 12 – MDB-12	
184	R/W	Modbus Digital Input 13 – MDB-13	
185	R/W	Modbus Digital Input 14 – MDB-14	
186	R/W	Modbus Digital Input 15 – MDB-15	
187	R/W	Modbus Digital Input 16 – MDB-16	
188	R/W	Modbus Digital Input 17 – MDB-17	
189	R/W	Modbus Digital Input 18 – MDB-18	
190	R/W	Modbus Digital Input 19 – MDB-19	
191	R/W	Modbus Digital Input 20 – MDB-20	
192	R/W	Modbus Digital Input 21 – MDB-21	
193	R/W	Modbus Digital Input 22 – MDB-22	
194	R/W	Modbus Digital Input 23 – MDB-23	
195	R/W	Modbus Digital Input 24 – MDB-24	

## ...7 ADDRESSABLE PARAMETERS

### ...7.1 Coils

Coil Number	Read/Write	Description	Response Entry
<b>Totalizer Settings *</b>			
200	W	Totalizer 1 Stop Command	} 0 = Inactive 1 = Stops Totalizer Count
201	W	Totalizer 2 Stop Command	
202	W	Totalizer 3 Stop Command	
203	W	Totalizer 4 Stop Command	
204	W	Totalizer 5 Stop Command	
205	W	Totalizer 6 Stop Command	
206	W	Totalizer 7 Stop Command	
207	W	Totalizer 8 Stop Command	
208	W	Totalizer 9 Stop Command	
209	W	Totalizer 10 Stop Command	
210	W	Totalizer 11 Stop Command	
211	W	Totalizer 12 Stop Command	
212	W	Totalizer 1 Go Command	} 0 = Inactive 1 = Starts Totalizer Count
213	W	Totalizer 2 Go Command	
214	W	Totalizer 3 Go Command	
215	W	Totalizer 4 Go Command	
216	W	Totalizer 5 Go Command	
217	W	Totalizer 6 Go Command	
218	W	Totalizer 7 Go Command	
219	W	Totalizer 8 Go Command	
220	W	Totalizer 9 Go Command	
221	W	Totalizer 10 Go Command	
222	W	Totalizer 11 Go Command	
223	W	Totalizer 12 Go Command	
224	W	Totalizer 1 Reset Command	} 0 = Inactive 1 = Reset to Preset Value
225	W	Totalizer 2 Reset Command	
226	W	Totalizer 3 Reset Command	
227	W	Totalizer 4 Reset Command	
228	W	Totalizer 5 Reset Command	
229	W	Totalizer 6 Reset Command	
230	W	Totalizer 7 Reset Command	
231	W	Totalizer 8 Reset Command	
232	W	Totalizer 9 Reset Command	
233	W	Totalizer 10 Reset Command	
234	W	Totalizer 11 Reset Command	
235	W	Totalizer 12 Reset Command	
240	R	Totalizer 1 Stop/Go	} 0 = Stop 1 = Go
241	R	Totalizer 2 Stop/Go	
242	R	Totalizer 3 Stop/Go	
243	R	Totalizer 4 Stop/Go	
244	R	Totalizer 5 Stop/Go	
245	R	Totalizer 6 Stop/Go	
246	R	Totalizer 7 Stop/Go	
247	R	Totalizer 8 Stop/Go	
248	R	Totalizer 9 Stop/Go	
249	R	Totalizer 10 Stop/Go	
250	R	Totalizer 11 Stop/Go	
251	R	Totalizer 12 Stop/Go	

\* SR250A only

## 7.2 Holding Registers

Register Number	Read/Write	Description	Response Entry
<b>Analog Inputs</b>			
<b>Module A</b>			
001	R	Analog Input A1	}
002	R	Analog Input A2	
003	R	Analog Input A3	
004	R	Analog Input A4	
005	R	Analog Input A5	
006	R	Analog Input A6	
007	R	Engineering decimal point A1	}
008	R	Engineering decimal point A2	
009	R	Engineering decimal point A3	
010	R	Engineering decimal point A4	
011	R	Engineering decimal point A5	
012	R	Engineering decimal point A6	
<b>Module B</b>			
013	R	Analog Input B1	}
014	R	Analog Input B2	
015	R	Analog Input B3	
016	R	Analog Input B4	
017	R	Analog Input B5	
018	R	Analog Input B6	
019	R	Engineering decimal point B1	}
020	R	Engineering decimal point B2	
021	R	Engineering decimal point B3	
022	R	Engineering decimal point B4	
023	R	Engineering decimal point B5	
024	R	Engineering decimal point B6	
<b>Module C</b>			
025	R	Analog Input C1	}
026	R	Analog Input C2	
027	R	Analog Input C3	
028	R	Analog Input C4	
029	R	Analog Input C5	
030	R	Analog Input C6	
031	R	Engineering decimal point C1	}
032	R	Engineering decimal point C2	
033	R	Engineering decimal point C3	
034	R	Engineering decimal point C4	
035	R	Engineering decimal point C5	
036	R	Engineering decimal point C6	
<b>Module D</b>			
037	R	Analog Input D1	}
038	R	Analog Input D2	
039	R	Analog Input D3	
040	R	Analog Input D4	
041	R	Analog Input D5	
042	R	Analog Input D6	
043	R	Engineering decimal point D1	}
044	R	Engineering decimal point D2	
045	R	Engineering decimal point D3	
046	R	Engineering decimal point D4	
047	R	Engineering decimal point D5	
048	R	Engineering decimal point D6	

## ...7 ADDRESSABLE PARAMETERS

### ...7.2 Holding Registers

Register Number	Read/Write	Description	Response Entry
<b>Math Function Results *</b>			
050	R	Math block 1 Function Result	} Math Block n Display Full Scale +10% Math Block n Display Zero -10% -9999 to +9999
051	R	Math block 2 Function Result	
052	R	Math block 3 Function Result	
053	R	Math block 4 Function Result	
054	R	Math block 5 Function Result	
055	R	Math block 6 Function Result	
056	R	Math block 7 Function Result	
057	R	Math block 8 Function Result	
<b>Operator Message</b>			
060	R/W	Operator Message (Start of message)	} User defined, 2 characters per word (total 20 characters) Refer to Section 8 for Character Code Conversion
061	R/W	Operator Message	
062	R/W	Operator Message	
063	R/W	Operator Message	
064	R/W	Operator Message	
065	R/W	Operator Message	
066	R/W	Operator Message	
067	R/W	Operator Message	
068	R/W	Operator Message	
069	R/W	Operator Message (End of message)	
<b>Totalizer Decimal Point Position *</b>			
070	R	Totalizer 1 Decimal Point Position	} 0 to 8 = No. of Chars Before Dec. point, 9 = x10 Multiplier, 10 = x100 Multiplier
071	R	Totalizer 2 Decimal Point Position	
072	R	Totalizer 3 Decimal Point Position	
073	R	Totalizer 4 Decimal Point Position	
074	R	Totalizer 5 Decimal Point Position	
075	R	Totalizer 6 Decimal Point Position	
076	R	Totalizer 7 Decimal Point Position	
077	R	Totalizer 8 Decimal Point Position	
078	R	Totalizer 9 Decimal Point Position	
079	R	Totalizer 10 Decimal Point Position	
080	R	Totalizer 11 Decimal Point Position	
081	R	Totalizer 12 Decimal Point Position	
<b>Chart Speed and Paper Length</b>			
085	R/W	Chart Speed 1	} 0 to 1500mm per hour (Chart Speed 0 preset to 0mm per hour)
086	R/W	Chart Speed 2	
087	R/W	Chart Speed 3	
088	R	Actual Chart Speed	
089	R/W	Active Chart Speed	0 = CS 0, 1 = CS 1, 1 = CS 2, 2 = CS 3
090	R	Remaining Chart	0 to 30 metres

\* SR250A only

## ...7.2 Holding Registers

Register Number	Read/Write	Description	Response Entry
<b>Alarm Trip Points</b>			
095	R/W	Process Alarm PaA Trip Point	}
096	R/W	PaB Trip Point	
097	R/W	PaC Trip Point	
098	R/W	PaD Trip Point	
099	R/W	PaE Trip Point	
100	R/W	PaF Trip Point	
101	R/W	PaG Trip Point	
102	R/W	PaH Trip Point	
103	R/W	PaJ Trip Point	
104	R/W	PaK Trip Point	
105	R/W	PaL Trip Point	
106	R/W	PaM Trip Point	
107	R/W	PaN Trip Point	
108	R/W	PaP Trip Point	
109	R/W	PaQ Trip Point	
110	R/W	PaR Trip Point	
111	R/W	PaS Trip Point	
112	R/W	PaT Trip Point	
113	R/W	PaU Trip Point	
114	R/W	PaV Trip Point	
115	R/W	PaW Trip Point	
116	R/W	PaX Trip Point	
117	R/W	PaY Trip Point	
118	R/W	PaZ Trip Point	
<b>Alarm Hysteresis</b>			
120	R/W	Process Alarm PaA Hysteresis	}
121	R/W	PaB Hysteresis	
122	R/W	PaC Hysteresis	
123	R/W	PaD Hysteresis	
124	R/W	PaE Hysteresis	
125	R/W	PaF Hysteresis	
126	R/W	PaG Hysteresis	
127	R/W	PaH Hysteresis	
128	R/W	PaJ Hysteresis	
129	R/W	PaK Hysteresis	
130	R/W	PaL Hysteresis	
131	R/W	PaM Hysteresis	
132	R/W	PaN Hysteresis	
133	R/W	PaP Hysteresis	
134	R/W	PaQ Hysteresis	
135	R/W	PaR Hysteresis	
136	R/W	PaS Hysteresis	
137	R/W	PaT Hysteresis	
138	R/W	PaU Hysteresis	
139	R/W	PaV Hysteresis	
140	R/W	PaW Hysteresis	
141	R/W	PaX Hysteresis	
142	R/W	PaY Hysteresis	
143	R/W	PaZ Hysteresis	

-9999 to +9999

## ...7 ADDRESSABLE PARAMETERS

### ...7.2 Holding Registers

Register Number	Read/Write	Description	Response Entry
<b>Alarm Time Hysteresis</b>			
150	R/W	Process Alarm PaA Time Hysteresis	-9999 to +9999
151	R/W	PaB Time Hysteresis	
152	R/W	PaC Time Hysteresis	
153	R/W	PaD Time Hysteresis	
154	R/W	PaE Time Hysteresis	
155	R/W	PaF Time Hysteresis	
156	R/W	PaG Time Hysteresis	
157	R/W	PaH Time Hysteresis	
158	R/W	PaJ Time Hysteresis	
159	R/W	PaK Time Hysteresis	
160	R/W	PaL Time Hysteresis	
161	R/W	PaM Time Hysteresis	
162	R/W	PaN Time Hysteresis	
163	R/W	PaP Time Hysteresis	
164	R/W	PaQ Time Hysteresis	
165	R/W	PaR Time Hysteresis	
166	R/W	PaS Time Hysteresis	
167	R/W	PaT Time Hysteresis	
168	R/W	PaU Time Hysteresis	
169	R/W	PaV Time Hysteresis	
170	R/W	PaW Time Hysteresis	
171	R/W	PaX Time Hysteresis	
172	R/W	PaY Time Hysteresis	
173	R/W	PaZ Time Hysteresis	
<b>Math Constants *</b>			
180	R/W	Math block constant K1	-9999 to +9999
181	R/W	Math block constant K2	
182	R/W	Math block constant K3	
183	R/W	Math block constant K4	
184	R/W	Math block constant K5	
185	R/W	Math block constant K6	
186	R/W	Math block constant K7	
187	R/W	Math block constant K8	
188	R/W	Math block constant K9	
189	R/W	Math block constant K10	
190	R/W	Math block constant K11	
191	R/W	Math block constant K12	
192	R/W	Math block constant K13	
193	R/W	Math block constant K14	
194	R/W	Math block constant K15	
195	R/W	Math block constant K16	
<b>Math Constant Decimal Point *</b>			
200	R/W	K1 decimal point	0 to 3
201	R/W	K2 decimal point	
202	R/W	K3 decimal point	
203	R/W	K4 decimal point	
204	R/W	K5 decimal point	
205	R/W	K6 decimal point	
206	R/W	K7 decimal point	
207	R/W	K8 decimal point	
208	R/W	K9 decimal point	
209	R/W	K10 decimal point	
210	R/W	K11 decimal point	
211	R/W	K12 decimal point	
212	R/W	K13 decimal point	
213	R/W	K14 decimal point	
214	R/W	K15 decimal point	
215	R/W	K16 decimal point	

\* SR250A Only

## ...7.2 Holding Registers

Register Number	Read/Write	Description	Response Entry
		<b>Totalizer Settings *</b>	
		<b>Totalizer 1 Preset Value</b>	} (High Word x 65536) + Low Word together is 0 to 99,999,999
220	R/W	High Word	
221	R/W	Low Word	
		<b>Totalizer 2 Preset Value</b>	
222	R/W	High Word	
223	R/W	Low Word	
		<b>Totalizer 3 Preset Value</b>	
224	R/W	High Word	
225	R/W	Low Word	
		<b>Totalizer 4 Preset Value</b>	
226	R/W	High Word	
227	R/W	Low Word	
		<b>Totalizer 5 Preset Value</b>	
228	R/W	High Word	
229	R/W	Low Word	
		<b>Totalizer 6 Preset Value</b>	
230	R/W	High Word	
231	R/W	Low Word	
		<b>Totalizer 7 Preset Value</b>	
232	R/W	High Word	
233	R/W	Low Word	
		<b>Totalizer 8 Preset Value</b>	
234	R/W	High Word	
235	R/W	Low Word	
		<b>Totalizer 9 Preset Value</b>	
236	R/W	High Word	
237	R/W	Low Word	
		<b>Totalizer 10 Preset Value</b>	
238	R/W	High Word	
239	R/W	Low Word	
		<b>Totalizer 11 Preset Value</b>	
240	R/W	High Word	
241	R/W	Low Word	
		<b>Totalizer 12 Preset Value</b>	
242	R/W	High Word	
243	R/W	Low Word	

\* SR250A only

## ...7 ADDRESSABLE PARAMETERS

### ...7.2 Holding Registers

Register Number	Read/Write	Description	Response Entry
		<b>Totalizer Settings *</b>	
		<b>Totalizer 1 Predetermined Value</b>	(High Word x 65536) + Low Word together is 0 to 99,999,999
250	R/W	High Word	
251	R/W	Low Word	
		<b>Totalizer 2 Predetermined Value</b>	
252	R/W	High Word	
253	R/W	Low Word	
		<b>Totalizer 3 Predetermined Value</b>	
254	R/W	High Word	
255	R/W	Low Word	
		<b>Totalizer 4 Predetermined Value</b>	
256	R/W	High Word	
257	R/W	Low Word	
		<b>Totalizer 5 Predetermined Value</b>	
258	R/W	High Word	
259	R/W	Low Word	
		<b>Totalizer 6 Predetermined Value</b>	
260	R/W	High Word	
261	R/W	Low Word	
		<b>Totalizer 7 Predetermined Value</b>	
262	R/W	High Word	
263	R/W	Low Word	
		<b>Totalizer 8 Predetermined Value</b>	
264	R/W	High Word	
265	R/W	Low Word	
		<b>Totalizer 9 Predetermined Value</b>	
266	R/W	High Word	
267	R/W	Low Word	
		<b>Totalizer 10 Predetermined Value</b>	
268	R/W	High Word	
269	R/W	Low Word	
		<b>Totalizer 11 Predetermined Value</b>	
270	R/W	High Word	
271	R/W	Low Word	
		<b>Totalizer 12 Predetermined Value</b>	
272	R/W	High Word	
273	R/W	Low Word	

\* SR250A only

...7.2 Holding Registers

Register Number	Read/Write	Description	Response Entry
		<b>Totalizer Settings *</b>	
		<b>Totalizer 1 Batch Total</b>	(High Word x 65536) + Low Word together is 0 to 99,999,999
280	R	High Word	
281	R	Low Word	
		<b>Totalizer 2 Batch Total</b>	
282	R	High Word	
283	R	Low Word	
		<b>Totalizer 3 Batch Total</b>	
284	R	High Word	
285	R	Low Word	
		<b>Totalizer 4 Batch Total</b>	
286	R	High Word	
287	R	Low Word	
		<b>Totalizer 5 Batch Total</b>	
288	R	High Word	
289	R	Low Word	
		<b>Totalizer 6 Batch Total</b>	
290	R	High Word	
291	R	Low Word	
		<b>Totalizer 7 Batch Total</b>	
292	R	High Word	
293	R	Low Word	
		<b>Totalizer 8 Batch Total</b>	
294	R	High Word	
295	R	Low Word	
		<b>Totalizer 9 Batch Total</b>	
296	R	High Word	
297	R	Low Word	
		<b>Totalizer 10 Batch Total</b>	
298	R	High Word	
299	R	Low Word	
		<b>Totalizer 11 Batch Total</b>	
300	R	High Word	
301	R	Low Word	
		<b>Totalizer 12 Batch Total</b>	
302	R	High Word	
303	R	Low Word	

\* SR250A only

## 8 QUERY/RESPONSE DATA CODES

### 8.1 Operator Message Character Code Conversion

Character	Decimal	Hexadecimal
Space	32	20
!	33	21
"	34	22
#	35	23
\$	36	24
%	37	25
&	38	26
'	39	27
(	40	28
)	41	29
*	42	2A
+	43	2B
,	44	2C
-	45	2D
.	46	2E
/	47	2F
0	48	30
1	49	31
2	50	32
3	51	33
4	52	34
5	53	35
6	54	36
7	55	37
8	56	38
9	57	39
:	58	3A
;	59	3B
<	60	3C
=	61	3D
>	62	3E
?	63	3F
@	64	40
A	65	41
B	66	42
C	67	43
D	68	44
E	69	45
F	70	46
G	71	47
H	72	48
I	73	49
J	74	4A
K	75	4B
L	76	4C
M	77	4D
N	78	4E
O	79	4F
P	80	50

Character	Decimal	Hexadecimal
Q	81	51
R	82	52
S	83	53
T	84	54
U	85	55
V	86	56
W	87	57
X	88	58
Y	89	59
Z	90	5A
[	91	5B
\	92	5C
]	93	5D
^	94	5E
`	95	5F
~	96	60
a	97	61
b	98	62
c	99	63
d	100	64
e	101	65
f	102	66
g	103	67
h	104	68
i	105	69
j	106	6A
k	107	6B
l	108	6C
m	109	6D
n	110	6E
o	111	6F
p	112	70
q	113	71
r	114	72
s	115	73
t	116	74
u	117	75
v	118	76
w	119	77
x	120	78
y	121	79
z	122	7A
ƿ	123	7B
Ƃ	124	7C
Ω	125	7D
Σ	126	7E
μ	127	7F
π	128	80
◦	129	81

# PRODUCTS & CUSTOMER SUPPORT

## A Comprehensive Instrumentation Range

### Analytical Instrumentation

- **Transmitters**  
On-line pH, conductivity, and dissolved oxygen transmitters and associated sensing systems.
- **Sensors**  
pH, redox, selective ion, conductivity and dissolved oxygen.
- **Laboratory Instrumentation**  
pH and dissolved oxygen meters and associated sensors.
- **Water Analyzers**  
For water quality monitoring in environmental, power generation and general industrial applications including: pH, conductivity, ammonia, nitrate, phosphate, silica, sodium, chloride, fluoride, dissolved oxygen and hydrazine.
- **Gas Analyzers**  
Zirconia, paramagnetic, infrared, thermal conductivity.

### Controllers & Recorders

- **Controllers**  
Digital display, electronic, pneumatic. Discrete single-loop and multi-loop controllers which can be linked to a common display station, process computer or personal computer.
- **Recorders**  
Circular and strip-chart types (single and multi-point) for temperature, pressure, flow and many other process measurements.

### Electronic Transmitters

- **Smart & Analog Transmitters**  
For draft, differential, gauge and absolute pressure measurement. Also, liquid level and temperature
- **I to P Converters and Field Indicators**

### Flow Metering

- **Magnetic Flowmeters**  
Electromagnetic, insertion type probes and watermeters.
- **Turbine Flowmeters**
- **Wedge Flow Elements**
- **Mass Flow Meters**  
Transmitters, sensors, controllers and batch/display units.

### Level Control

- **Submersible, Capacitance & Conductivity.**

### Pneumatic Instrumentation

- **Transmitters**
- **Indicating Controllers**
- **Recording Controllers**

## Customer Support

ABB Instrumentation provides a comprehensive after sales service via a Worldwide Service Organization. Contact one of the following offices for details on your nearest Service and Repair Centre.

### United Kingdom

ABB Instrumentation Limited  
Tel: +44 (0)1480 475321  
Fax: +44 (0)1480 470787

### United States of America

ABB Automation Inc.  
Instrumentation Division  
Tel: +1 215-674-6000  
Fax: +1 215-674-7183

### Italy

ABB Instrumentation SpA  
Tel: +39 (0) 344 58111  
Fax: +39 (0) 344 58278

#### Client Warranty

Prior to installation, the equipment referred to in this manual must be stored in a clean, dry environment, in accordance with the Company's published specification. Periodic checks must be made on the equipment's condition.

In the event of a failure under warranty, the following documentation must be provided as substantiation:

1. A listing evidencing process operation and alarm logs at time of failure.
2. Copies of operating and maintenance records relating to the alleged faulty unit.



---

**ABB Instrumentation Ltd**

St. Neots  
Cams.  
England, PE19 3EU  
Tel: +44 (0) 1480 475321  
Fax: +44 (0) 1480 217948

**ABB Automation Inc.  
Instrumentation Division**

125 E. County Line Road  
Warminster, PA 18974 USA  
Tel: +1 215-674-6000  
Fax: +1 215-674-7183

**ABB Instrumentation SpA**

22016 Lenno  
Como  
Italy  
Tel: +39 (0) 344 58111  
Fax: +39 (0) 344 58278

The Company's policy is one of continuous product improvement and the right is reserved to modify the information contained herein without notice.

© ABB 2000

Printed in UK (03.00)