

# C1900 Series Circular Chart Recorder / Controllers

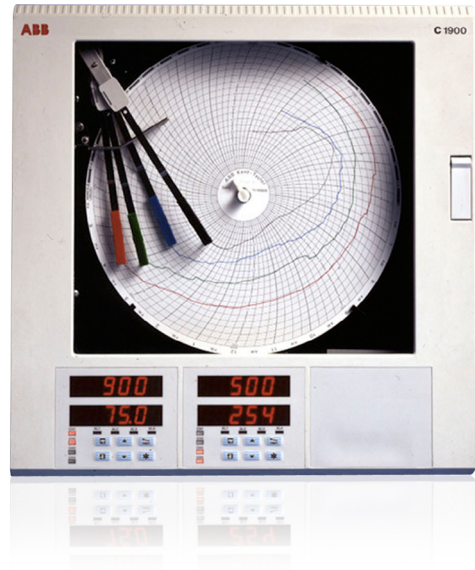

# The Company

We are an established world force in the design and manufacture of measurement products for industrial process control, flow measurement, gas and liquid analysis and environmental applications.

As a part of ABB, a world leader in process automation technology, we offer customers application expertise, service and support worldwide.

We are committed to teamwork, high quality manufacturing, advanced technology and unrivalled service and support.

The quality, accuracy and performance of the Company's products result from over 100 years experience, combined with a continuous program of innovative design and development to incorporate the latest technology.

EN ISO 9001:2000



Cert. No. Q 05907

EN 29001 (ISO 9001)



Lenno, Italy – Cert. No. 9/90A

Stonehouse, U.K.



0255

## Electrical Safety

This equipment complies with the requirements of CEI/IEC 61010-1:2001-2 'Safety Requirements for Electrical Equipment for Measurement, Control and Laboratory Use'. If the equipment is used in a manner NOT specified by the Company, the protection provided by the equipment may be impaired.

## Symbols

One or more of the following symbols may appear on the equipment labelling:

	<b>Warning</b> – Refer to the manual for instructions
	<b>Caution</b> – Risk of electric shock
	Protective earth (ground) terminal
	Earth (ground) terminal

	Direct current supply only
	Alternating current supply only
	Both direct and alternating current supply
	The equipment is protected through double insulation

Information in this manual is intended only to assist our customers in the efficient operation of our equipment. Use of this manual for any other purpose is specifically prohibited and its contents are not to be reproduced in full or part without prior approval of the Technical Publications Department.

### Health and Safety

To ensure that our products are safe and without risk to health, the following points must be noted:

1. The relevant sections of these instructions must be read carefully before proceeding.
2. Warning labels on containers and packages must be observed.
3. Installation, operation, maintenance and servicing must only be carried out by suitably trained personnel and in accordance with the information given.
4. Normal safety precautions must be taken to avoid the possibility of an accident occurring when operating in conditions of high pressure and/or temperature.
5. Chemicals must be stored away from heat, protected from temperature extremes and powders kept dry. Normal safe handling procedures must be used.
6. When disposing of chemicals ensure that no two chemicals are mixed.

Safety advice concerning the use of the equipment described in this manual or any relevant hazard data sheets (where applicable) may be obtained from the Company address on the back cover, together with servicing and spares information.

# CONTENTS

Section	Page
<b>1 INTRODUCTION .....</b>	<b>1</b>
<b>2 SETTING UP .....</b>	<b>2</b>
2.1 Instrument Power-up .....	2
2.1.1 Power-up Error Codes .....	3
2.2 Fitting the Chart .....	4
2.3 Fitting the Pen Capsule(s) .....	4
<b>3 DISPLAYS &amp; CONTROLS .....</b>	<b>5</b>
3.1 Displays and LED Indicators .....	5
3.2 Use of Controls .....	7
<b>4 GENERAL OPERATION .....</b>	<b>8</b>
4.1 Input Error Messages .....	9
<b>5 CONTROL OPERATION .....</b>	<b>10</b>
5.1 Operating Page Introduction .....	12
5.1.1 Set Point Tracking .....	12
5.1.2 Auto/Manual Transfer .....	12
5.1.3 Profile Control .....	12
5.1.4 Cascade Control .....	12
5.1.5 Heat/Cool Control .....	12
5.2 Operating Page Displays .....	13
5.3 Alarm Acknowledge Page .....	16
5.3.1 Alarm Indications .....	16
5.3.2 Acknowledging Alarms .....	16
5.3.3 Using the Alarm Acknowledge Page .....	16
5.4 Totals Page Displays .....	17
5.5 Access to Configuration Levels .....	18
5.5.1 Security Code Page .....	18
5.6 Profile States Page .....	19
5.7 Auto-tuning Introduction .....	20
5.7.1 Auto-tuning Page .....	21
5.8 Auto-tune Diagnostic Messages .....	24
5.9 Introduction to Standard Control .....	25
5.9.1 Control Page (Standard Control) .....	30
5.10 Introduction to Heat/Cool Control .....	31
5.10.1 Control Page (Heat/Cool Control) .....	32
5.10.2 Calculating the Crossover Value .....	33
5.10.3 Calculating the Transition Bandwidth Value .....	33
<b>6 RECORD OPERATION .....</b>	<b>34</b>
6.1 Operating Page Displays .....	35
6.2 Alarm Acknowledge Page .....	36
6.2.1 Alarm Indications .....	36
6.2.2 Acknowledging Alarms .....	36
6.2.3 Using the Alarm Acknowledge Page .....	36
6.3 Totals Page Displays .....	37
<b>7 SIMPLE FAULT FINDING .....</b>	<b>38</b>
<b>8 SPARES LIST .....</b>	<b>39</b>

# 1 INTRODUCTION

The documentation for the C1900 series of circular chart recorders is shown in Fig. 1.1. The **Standard Manuals**, including the specification sheet, are supplied with all instruments. The **Supplementary Manuals** supplied depend on the specification of the instrument.

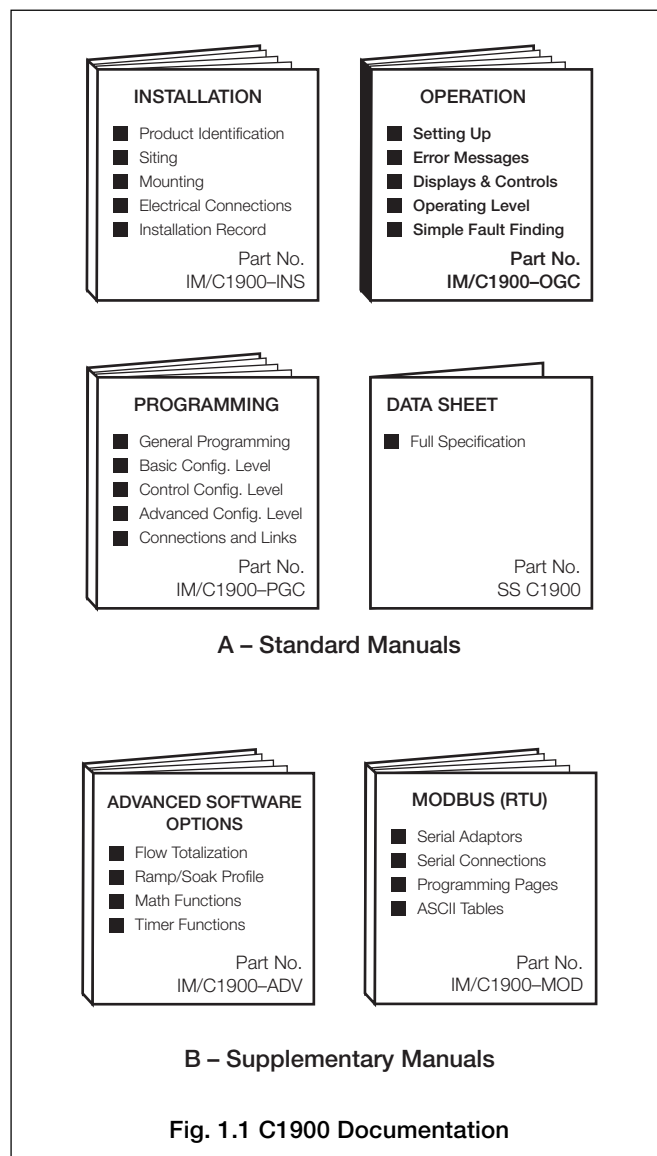

## 2 SETTING UP

### 2.1 Instrument Power-up – Fig. 2.1 and 2.2

**Caution.** Ensure that all connections, especially to the earth stud, are made correctly.

- Check that the input sensors are installed correctly.
- Check that the pen(s) are installed correctly – see Fig. 2.1.
- Switch on the supply to the instrument, any power-operated control circuits and the input signals. Wait for the pens to settle.

**Note.** On power-up, the pens are moved to an off-chart position for automatic referencing. Pen chatter may occur on those pens nearest the reference position. **This is a normal function of the instrument.**

- The start-up sequence shown in Fig. 2.2 is displayed on faceplate 1 when the supply is first switched on.

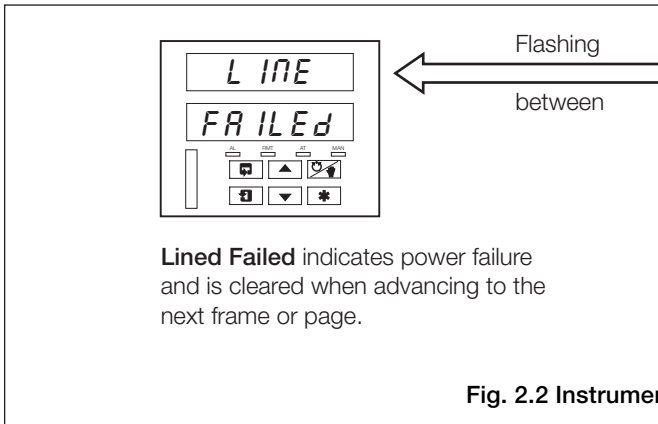
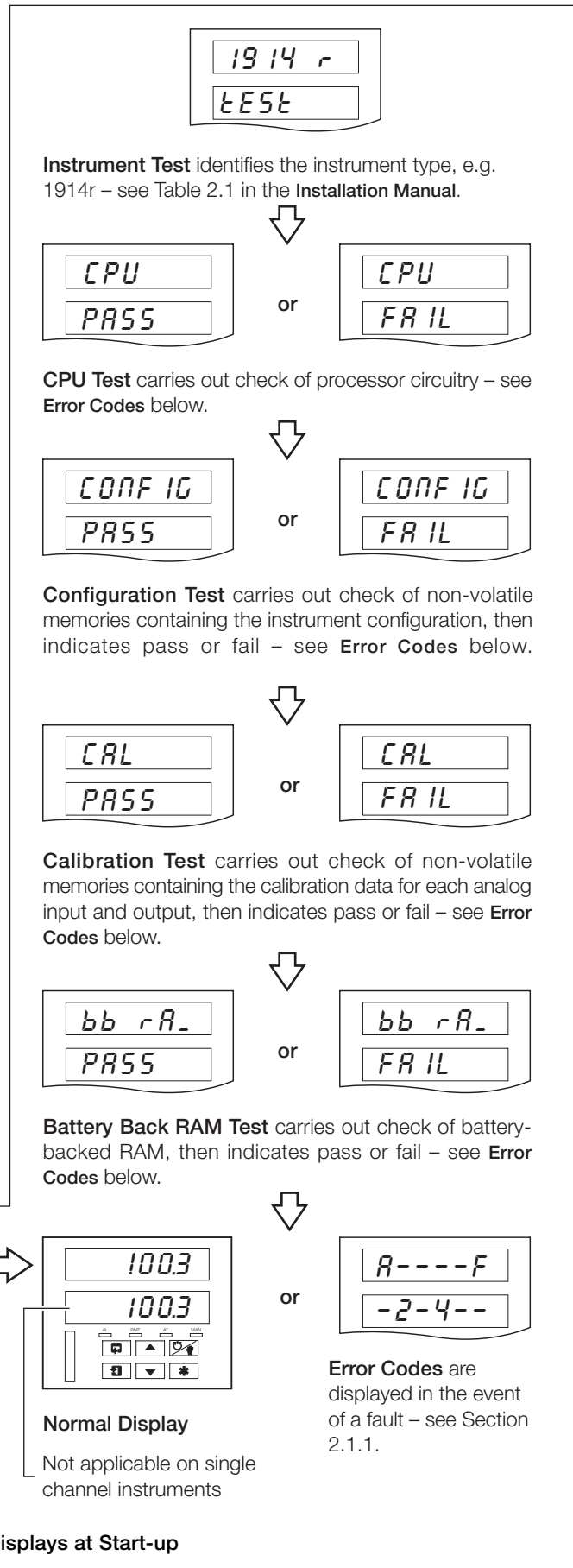
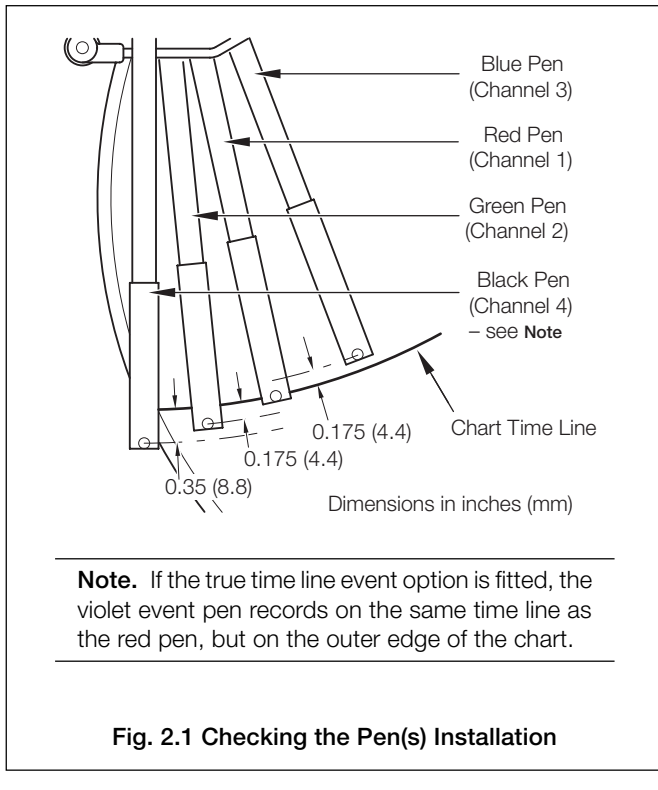

### 2.1.1 Power-up Error Codes

If any of the power-up tests fail (see Fig. 2.2), error codes are displayed to identify the fault. Refer to Fig. 2.3 for error code interpretations.

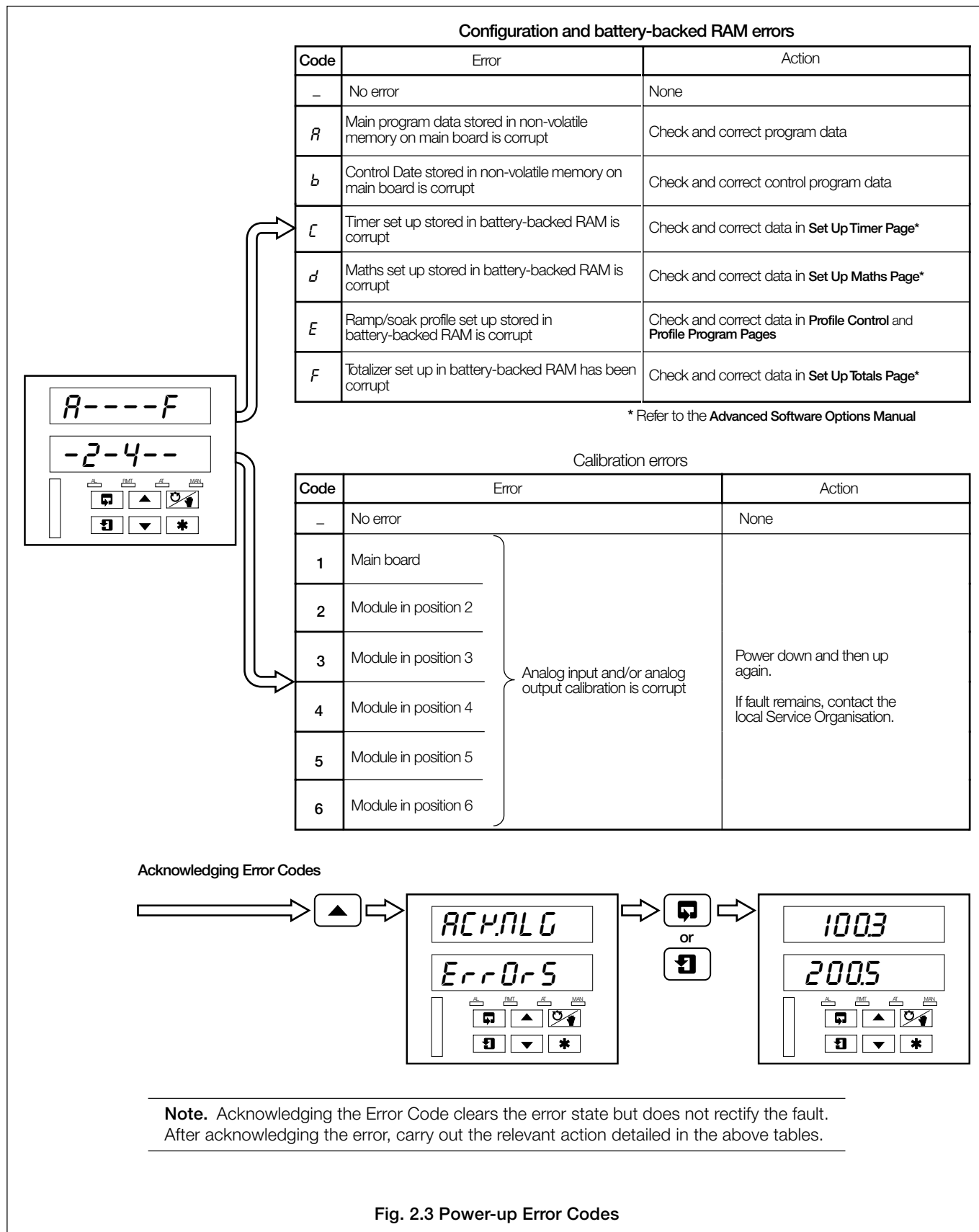

2.2 Fitting the Chart – Fig. 2.4

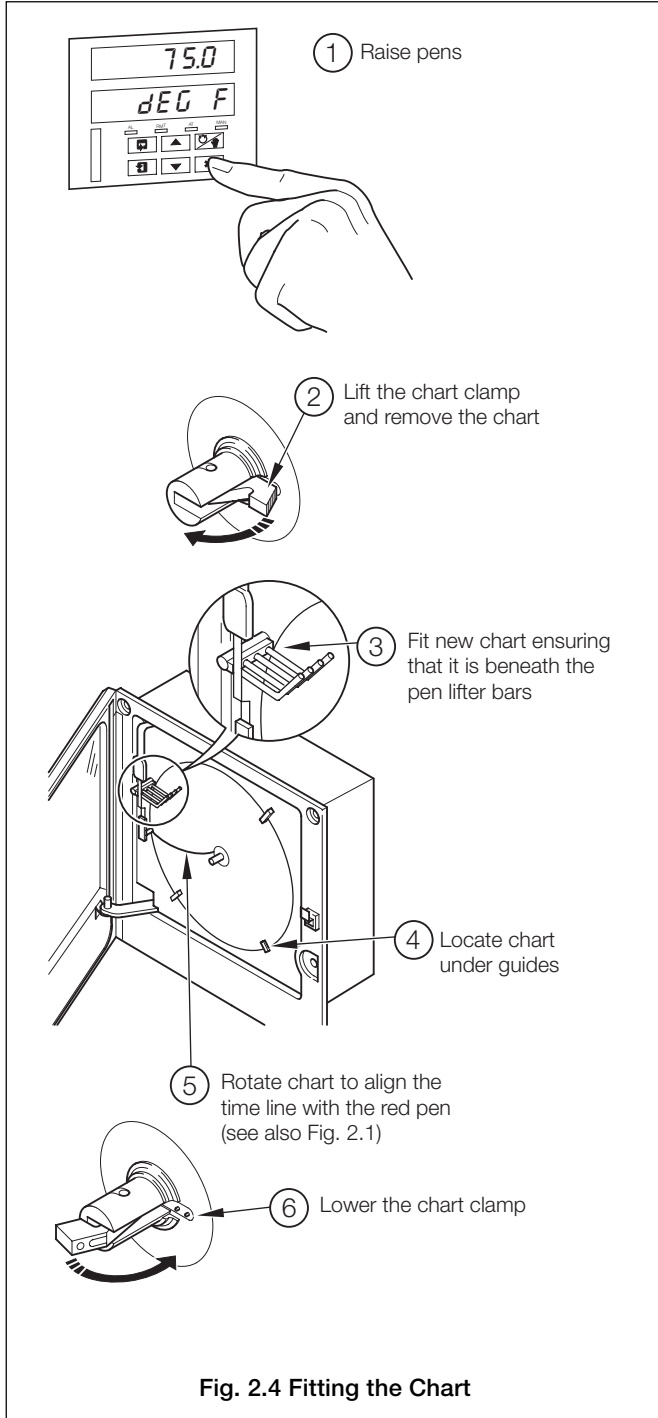

2.3 Fitting the Pen Capsule(s) – Fig. 2.5



### 3 DISPLAYS & CONTROLS

The displays, LED indicators and operation/programming controls are located on the faceplates on the front panel of the instrument – see Fig 3.1.

#### 3.1 Displays and LED Indicators – Fig. 3.1

The displays comprise 2 rows of 6 characters.

At the top of each programming page (the page header) both displays are used to describe the particular page selected.

When parameters within the selected page are viewed, the upper display shows the parameter and the lower display shows the value or setting for that parameter.

Alarm and Channel states are indicated by separate LEDs on the front panel faceplate(s) – see Fig. 3.1.

A	<i>A</i>	L	<i>L</i>
B	<i>b</i>	M	<i>-</i>
C	<i>C</i> or <i>c</i>	N	<i>n</i> or <i>n</i>
D	<i>d</i>	O	<i>0</i> or <i>o</i>
E	<i>E</i>	P	<i>P</i>
F	<i>F</i>	Q	<i>Q</i>
G	<i>G</i>	R	<i>r</i>
H	<i>H</i> or <i>h</i>	S	<i>S</i>
I	<i>I</i>	T	<i>t</i>
J	<i>J</i>	U	<i>U</i>
K	<i>K</i>	V	<i>V</i>
		Y	<i>Y</i>

Table 3.1 Character Set

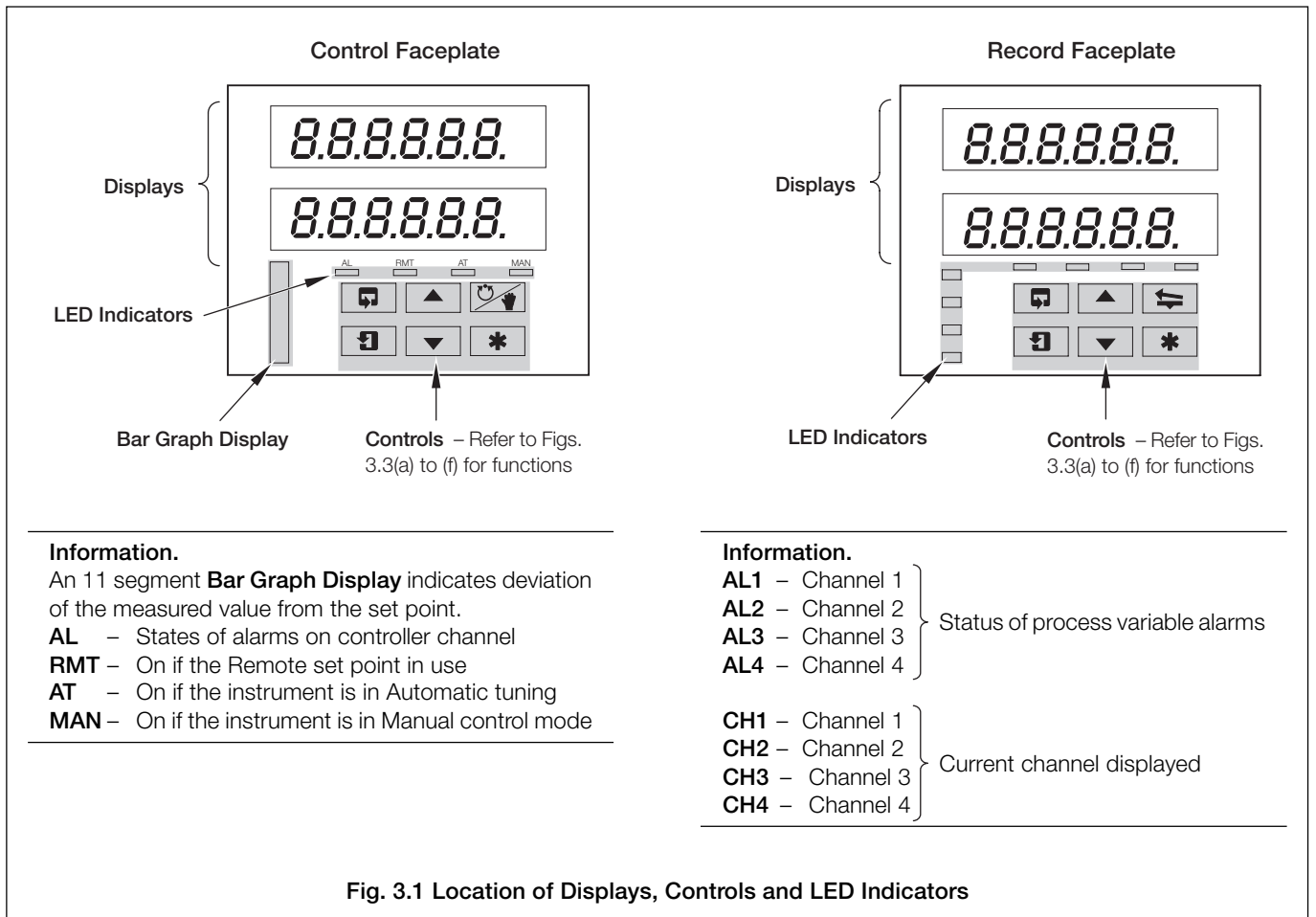

Fig. 3.1 Location of Displays, Controls and LED Indicators

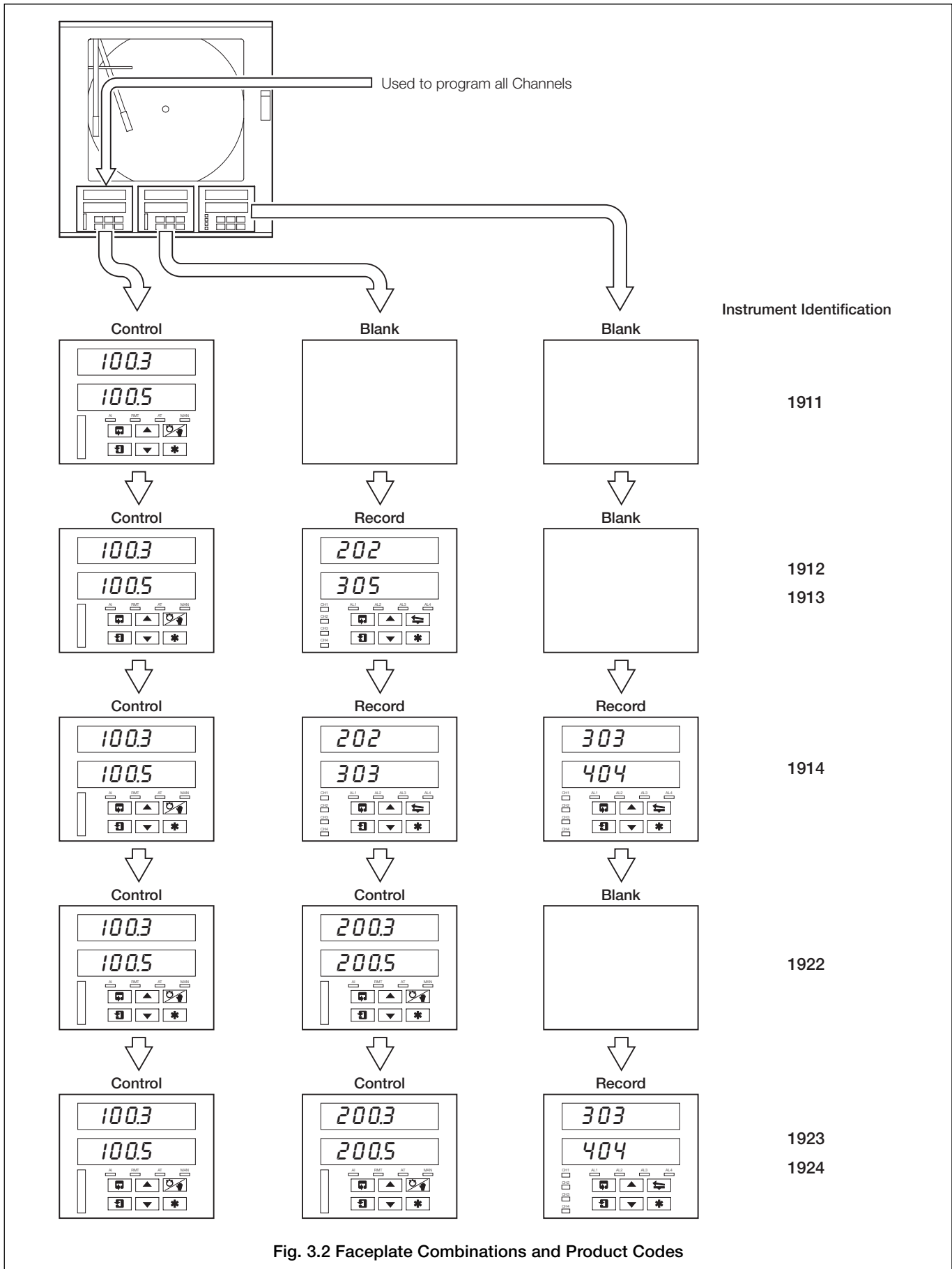

Fig. 3.2 Faceplate Combinations and Product Codes

3.2 Use of Controls – Fig. 3.3(a) to (g)

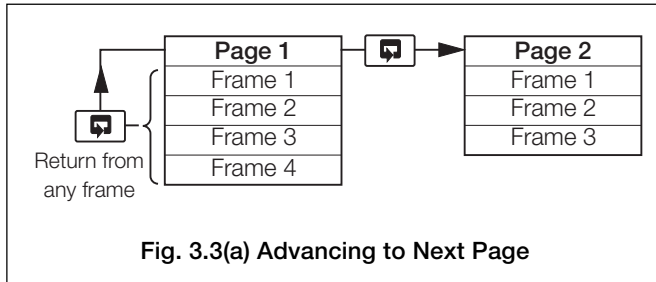

Fig. 3.3(a) Advancing to Next Page

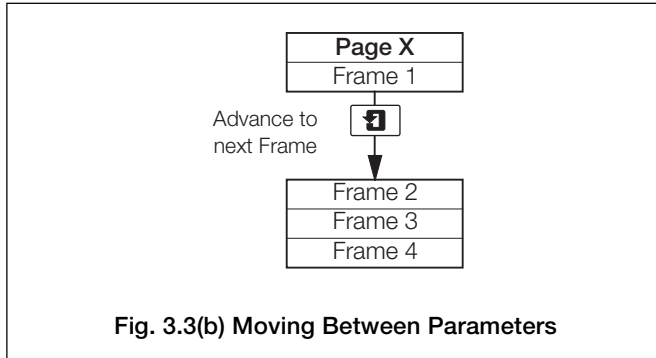

Fig. 3.3(b) Moving Between Parameters

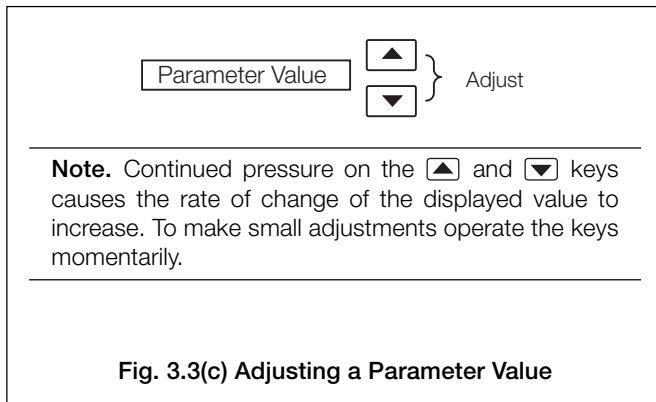

Fig. 3.3(c) Adjusting a Parameter Value

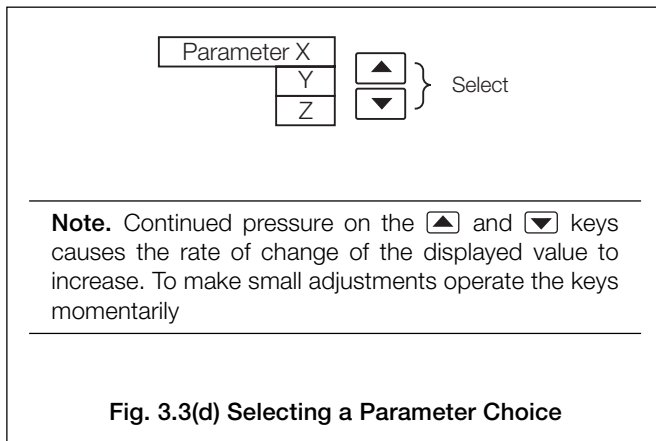

Fig. 3.3(d) Selecting a Parameter Choice

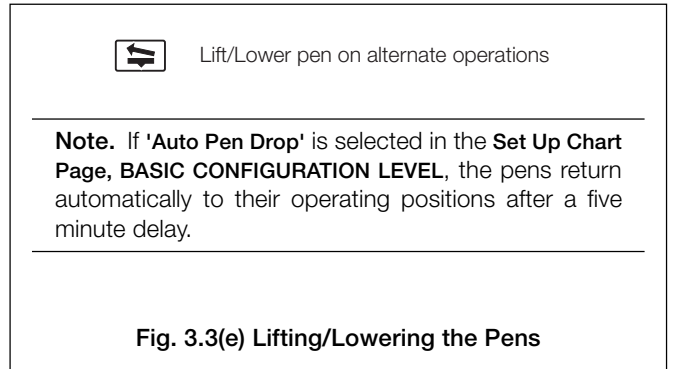

Fig. 3.3(e) Lifting/Lowering the Pens

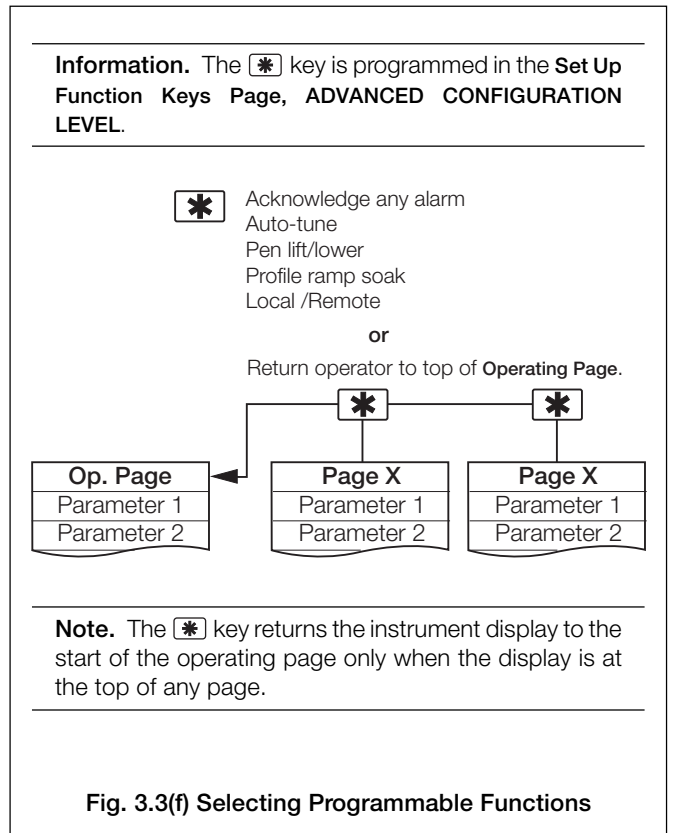

Fig. 3.3(f) Selecting Programmable Functions

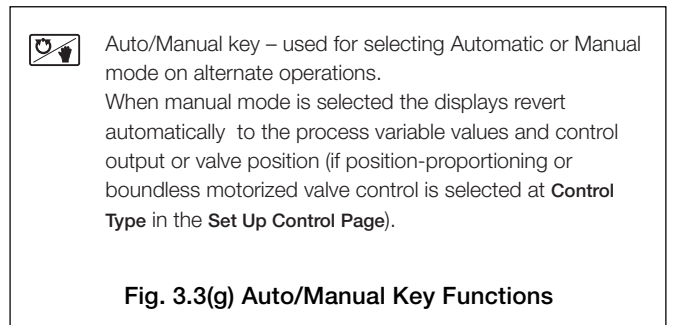
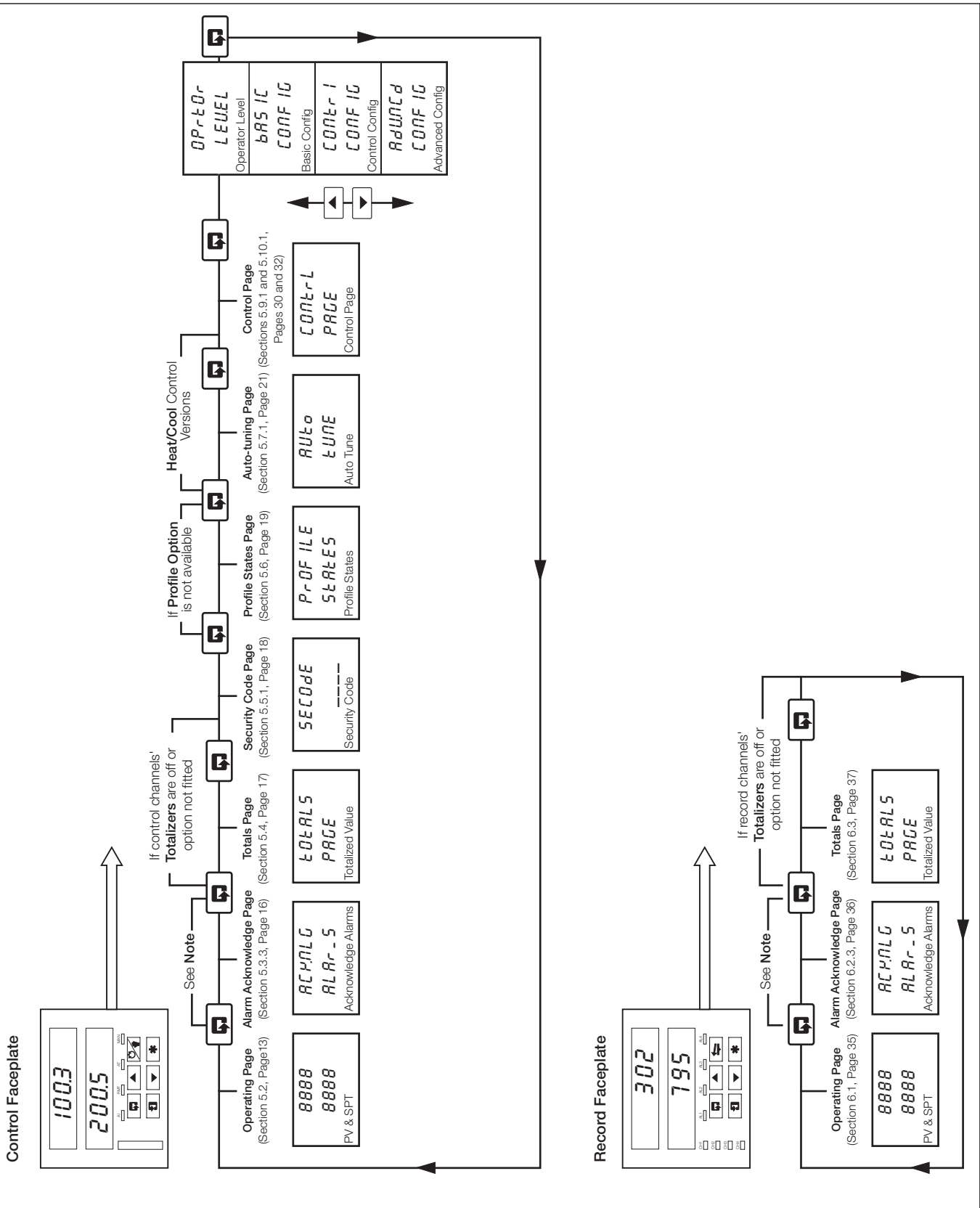

Fig. 3.3(g) Auto/Manual Key Functions

# 4 GENERAL OPERATION



**Note.** The Alarm Acknowledge pages are displayed only if an alarm is active.

Fig. 4.1 Summary of Operating Levels for Different Faceplate Types

The instrument has dedicated Operating Pages – see Fig. 4.1. These pages are used for general monitoring of the process measurements and are not affected by the security system which inhibits access to the programming and control pages only – see Section 5.5 on page 18.

4.1 Input Error Messages – Fig. 4.2

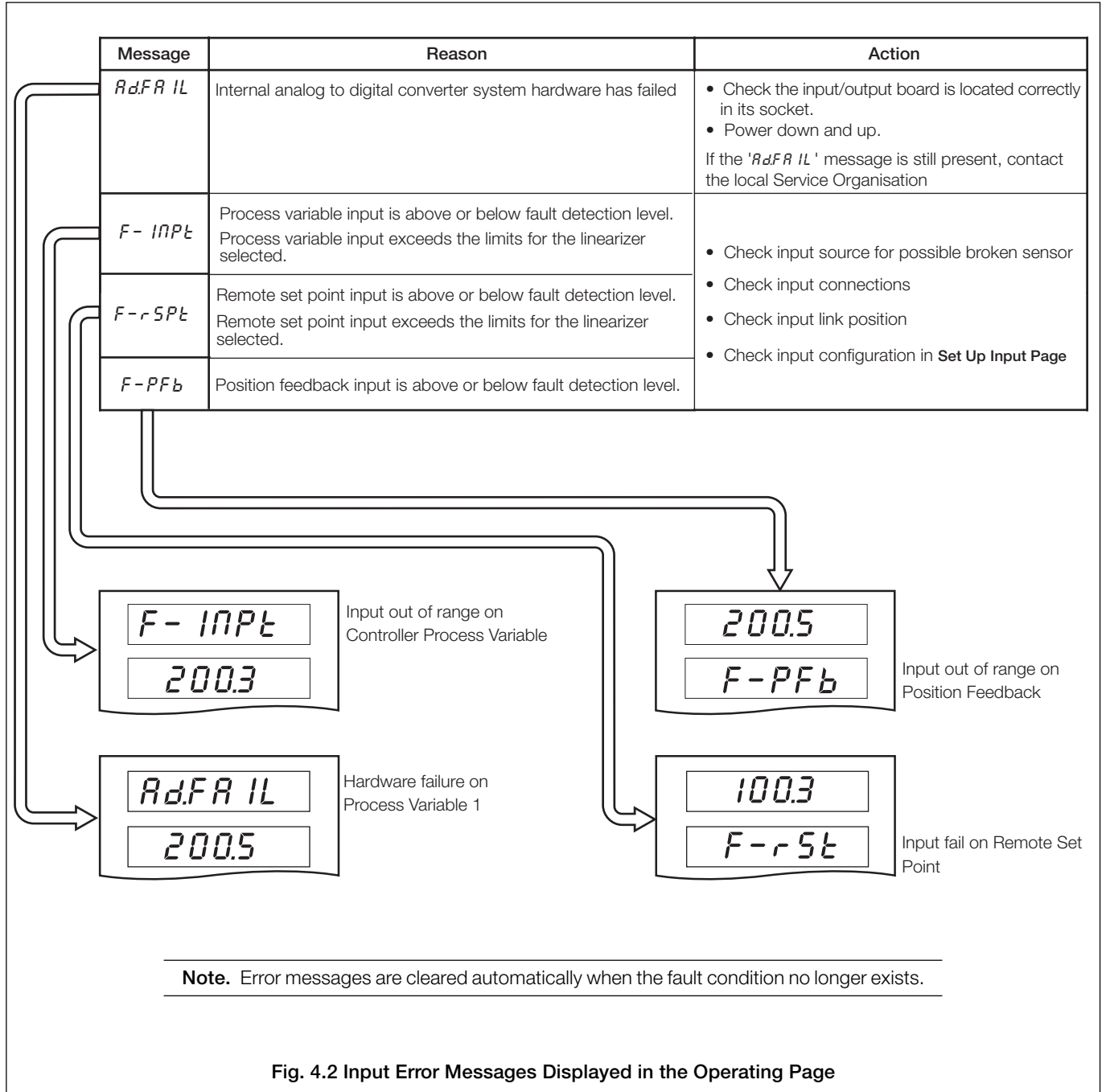

Fig. 4.2 Input Error Messages Displayed in the Operating Page

# 5 CONTROL OPERATION

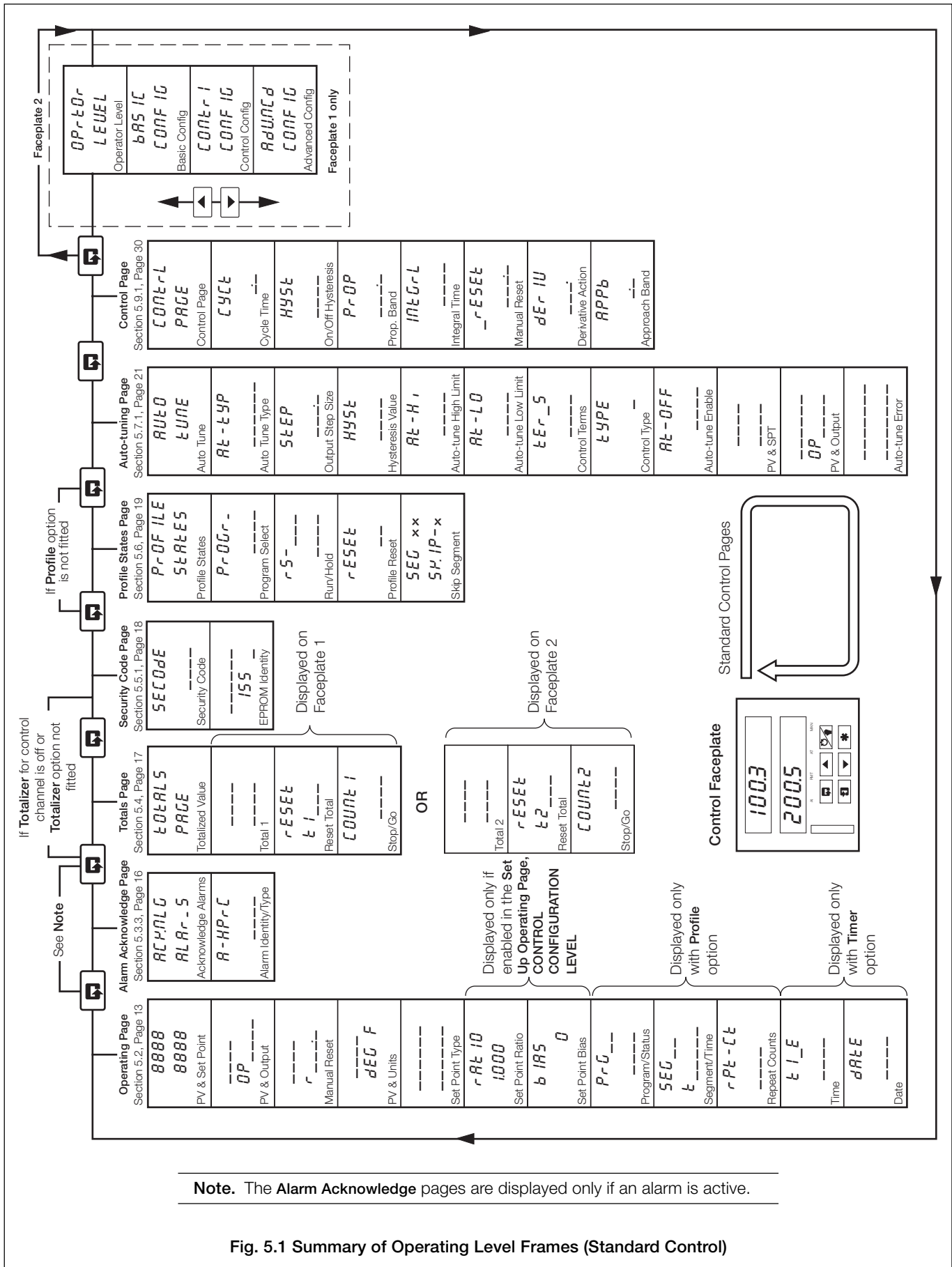
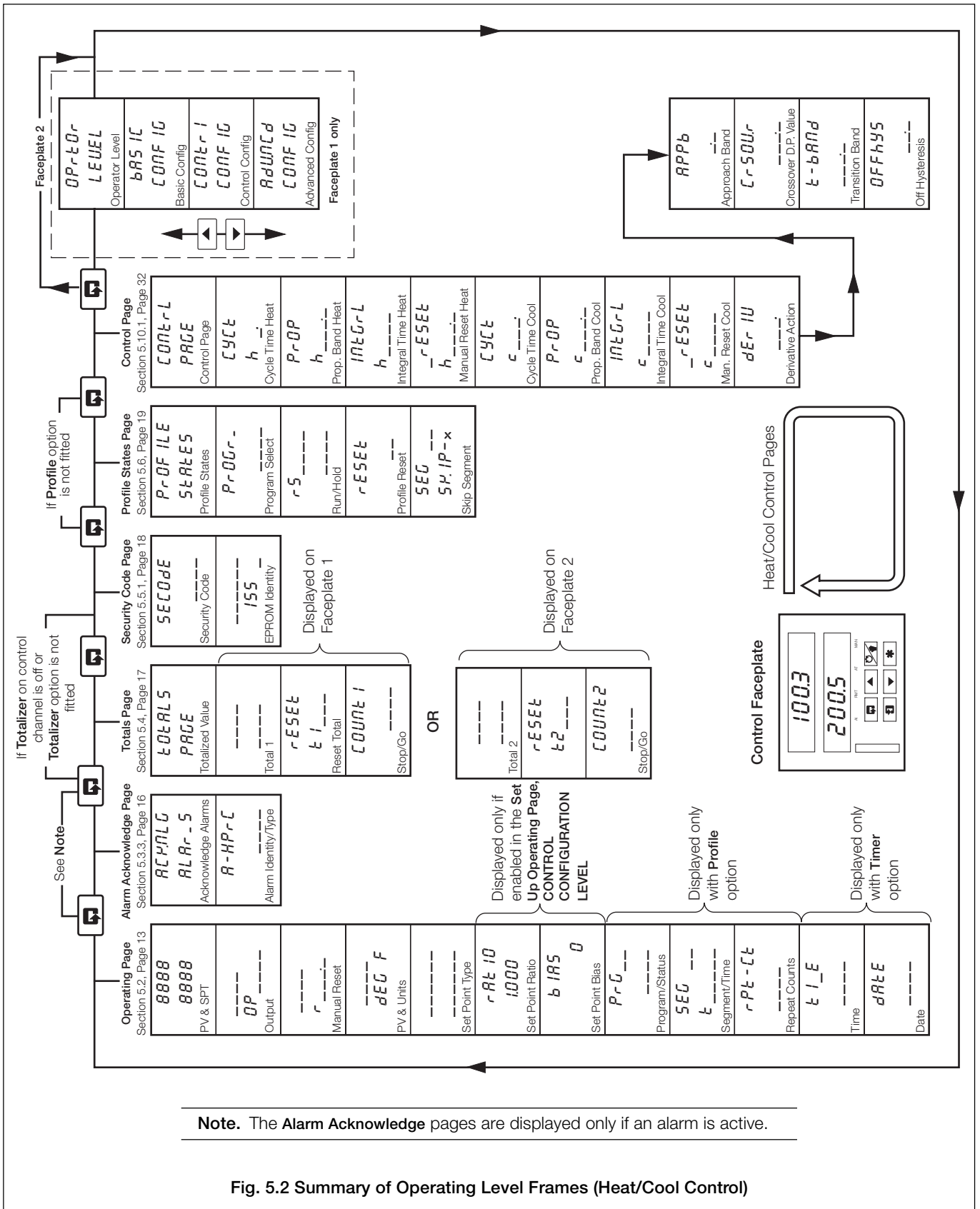

Fig. 5.1 Summary of Operating Level Frames (Standard Control)



5.1 Operating Page Introduction

5.1.1 Set Point Tracking

With set point tracking enabled (**Set Points Page, CONTROL CONFIGURATION LEVEL**) the local set point value tracks the process variable when the controller is in Manual control mode. In this mode of operation the set point limits do not apply. If the set point value is outside its limits when Automatic control mode is selected, the local set point remains outside its limits and can only be adjusted in one direction, towards its limits. Once inside the limits they apply as normal.

With remote set point tracking enabled, the local set point tracks the remote set point value when in the remote set point mode. In this mode of operation the local set point limits do not apply. If the set point value is outside its limits when the local set point value is selected, the local set point remains outside its limits and can only be adjusted in one direction, towards its limits. Once inside the limits they apply as normal.

5.1.2 Auto/Manual Transfer

All auto-to-manual transfers are bumpless. If the local set point is used and set point tracking is enabled, all manual-to-auto transfers are bumpless, since the set point is always at the same value as the process variable. Without set point tracking enabled, the response following a manual-to-auto transfer depends on the control settings. With an integral action setting the output is ramped up or down to remove any process variable offset from the set point (providing the process variable is within the proportional band). If the integral action is off, the output may step to a new value when the controller is transferred back to automatic control mode.

With remote set point tracking enabled, the control set point switches automatically from remote to local when manual mode is selected.

5.1.3 Profile Control – Fig. 5.3

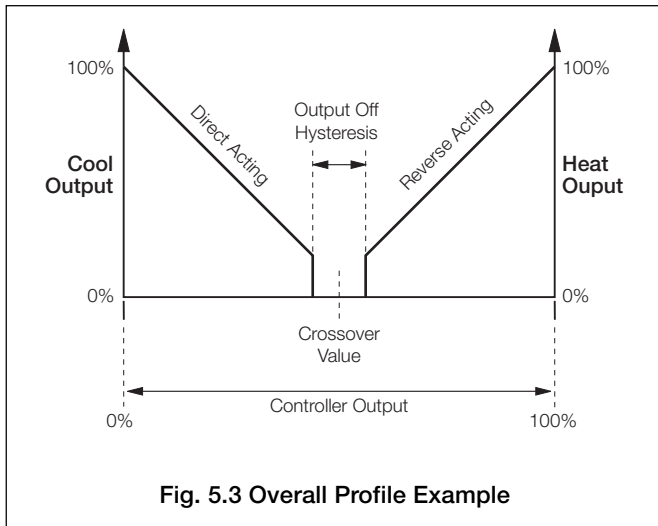

5.1.4 Cascade Control

The master in a cascade set-up is always channel 1 and the slave is always channel 2. If the slave is switched to manual control with cascade set point selected, the slave's set point reverts automatically to local set point.

Ratio and bias are applied to the master output value so that the slave's cascade set point value = Ratio x Master Output + Bias.

With **Output Tracking enabled** – if the slave is switched to manual mode or local set point, the master is switched automatically to manual. The manual output of the master tracks the local set point value of the slave. The value fed back to the master takes into account any ratio and bias settings.

With **Output Tracking disabled** – switching the slave to manual mode or local set point does not affect the operation of the master.

To return to full cascade control carry out the following procedure:

- a) Switch the Slave controller into automatic control mode.
- b) Switch the Slave Controller set point to 'Cascade'.
- c) Switch the Master controller to automatic control mode (if currently in Manual)

5.1.5 Heat/Cool Control – Fig. 5.4

When in automatic control mode both the heat and cool outputs are turned off when in the Output Off Hysteresis Band. In manual control mode the Output Off Hysteresis Band has no effect. If the PID output is within the Off Hysteresis Band when the controller is returned to auto control mode, the Off Hysteresis Band has no effect until either the PID output goes outside the band or becomes equal to the Crossover Value.

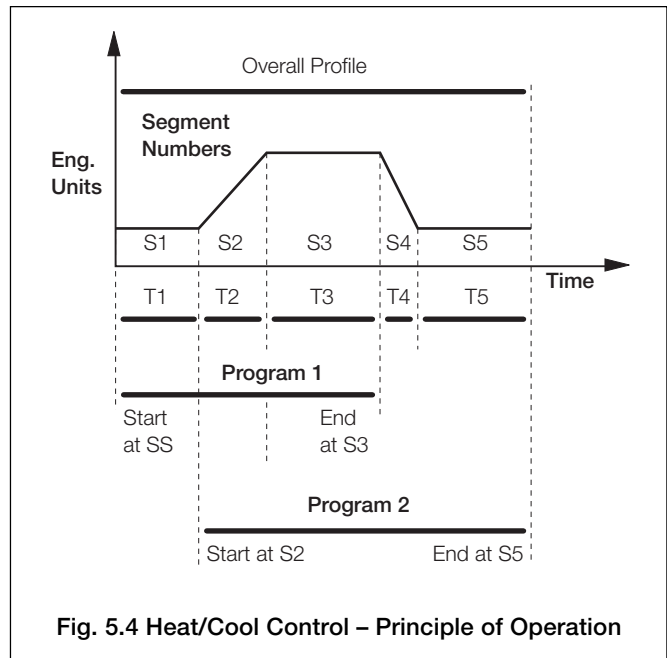

5.2 Operating Page Displays

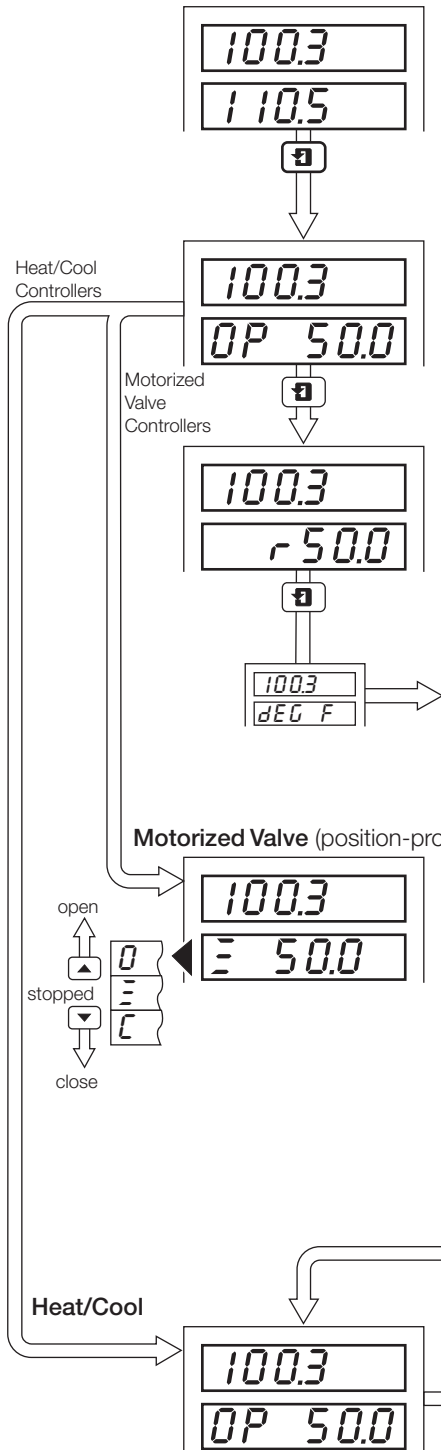

**Process Variable**

**Control Set Point**

The set point in use is displayed (Local, Remote, Dual or Cascade). If the Local or Dual set point is displayed it can be adjusted using the ▲ and ▼ keys, providing adjustment is enabled in the **Set Up Operating Page, CONTROL CONFIGURATION LEVEL** – refer to the **Programming Guide**.

**Process Variable**

**Control Output Value (%)**

To adjust the output value manually: select Manual control mode using the [MAN] key ('MAN' LED is illuminated) and then use the ▲ and ▼ keys to set the required value (between 0 and 100%).

**Process Variable**

**Manual Reset**

Use the ▲ and ▼ keys to set a value which eliminates any offset from the set point (between 0 and 100%). Manual reset only appears if enabled in the **Set Up Operating Page, CONTROL CONFIGURATION LEVEL** and the **Integral Action Time** in the **OPERATOR LEVEL** is 'OFF'.

Continued on next page.

**Motorized Valve (position-proportioning and boundless)**

**Process Variable**

**Valve Status and Valve Position (%)**

- valve stopped
- ⏏ valve opening
- ⏏ valve closing

The valve position is displayed as a percentage of its full travel position (not displayed on boundless controllers). To adjust the valve position manually: select Manual control mode using the [MAN] key ('MAN' LED is illuminated), then use the ▲ and ▼ keys to set the required valve position (▲ key opens the valve and ▼ key closes the valve). With neither key pressed the valve is stopped.

**PID Output (%)**

To adjust the output value manually: select Manual control mode using the [MAN] key ('MAN' LED is illuminated), then use the ▲ and ▼ keys to set the value required (between 0 and 100%).

**Heat Output (%)**

This frame is not displayed if the PID output is below the **Crossover Value**. The output can be adjusted using the ▲ and ▼ keys when in the Manual control mode.

**Cool Output (%)**

This frame is not displayed if the PID output is above the **Crossover Value**. The output can be adjusted using the ▲ and ▼ keys when in the Manual control mode.

...5.2 Operating Page Displays

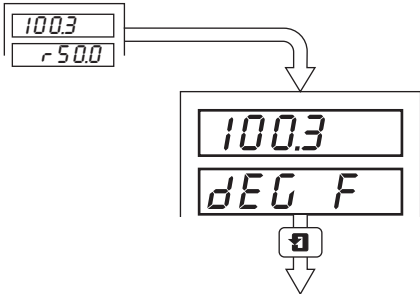

**Process Variable**

**Temperature Units**

The units are set in the **BASIC CONFIGURATION LEVEL**. Display is blank if 'NONE' is selected.

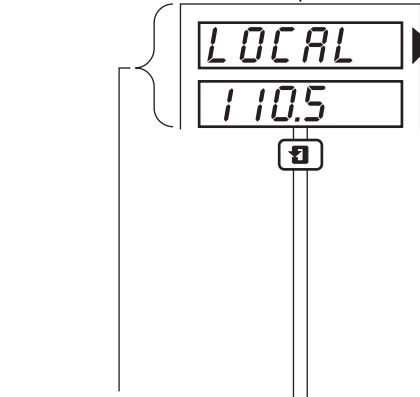

**Set Point Type Selection**

The **Balance** displays show the difference between the **Local** and **Second** set point values (remote, dual or cascade) when switching from local to second set point, i.e.

$$\text{Balance} = \text{Second set point} - \text{Local set point.}$$

If the difference is too great, press the key to return to the **Control Set Point** frame and adjust the Local set point to obtain an acceptable difference.

If remote set point tracking is enabled (**Set Points Page, CONTROL CONFIGURATION LEVEL**), the local set point tracks the remote set point when the remote set point is selected.

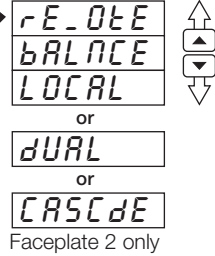

Displayed only if enabled in the **Set Up Operating Page, CONTROL CONFIGURATION LEVEL**

The key (if programmed in the **ADVANCED CONFIGURATION LEVEL**) can also be used for **Local/Second** set point selection, but transfer takes place without display of the Balance value, i.e.

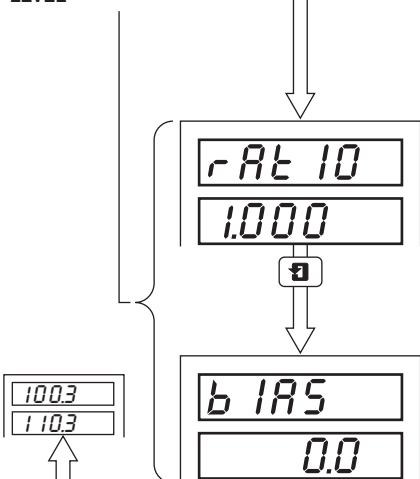
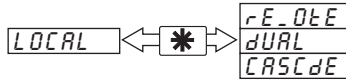

**Remote (or Cascade) Set Point Ratio**

The remote (or cascade) set point input (in engineering units) is multiplied by the ratio to obtain the control set point value, i.e.

$$\text{Remote (or cascade) Set Point Value} = \text{Input} \times \text{Ratio} + \text{Bias}$$

Use the and keys to set the ratio required, between 0.010 and 9.999 in 0.001 increments

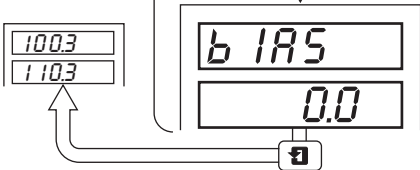

**Remote (or Cascade) Set Point Bias**

The bias value is added to the remote (cascade) set point value (see previous frame)

Use the and keys to set the bias required.

The bias can be set to either a positive or negative value (in engineering units).

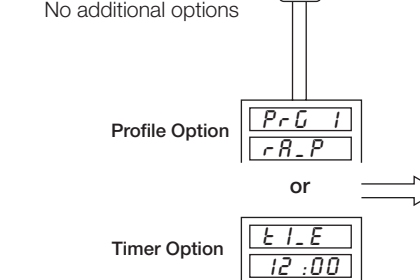

No additional options

Profile Option

Timer Option

Continued on next page.

...5.2 Operating Page Displays

Profile Option

b 1R5  
0.0

PrG 1  
rA\_P

Profile Program Selected

STOP  
rA\_P  
SOAK.  
HOLD  
H-HOLD  
r-HOLD  
r-rA-P  
END

Profile Status:

- STOP - waiting for run command, profile is inactive
- rA\_P - program is running and ramping
- SOAK. - program is running and soaking
- HOLD - operator hold or controller is in manual
- H-HOLD - holdback hold in hold, due to guaranteed ramp/soak hysteresis values being exceeded
- r-HOLD - retort function has placed controller in hold
- r-rA-P - retort function is ramping set point back to soak value
- END. - current program is completed but digital input signal is in 'Run' state.

Alternates between the two displays when extended soak is selected.

SEG 12  
E--h

E--h displays amount of time soak extended by.

Current Profile Segment

Time Remaining

Time remaining until the end of the current segment (in minutes or hours), depending on the Ramp/Soak Time Units set in the Profile Control Page, Advanced Software Options Manual. 'h' is displayed if hours are selected.

Use the ▲ or ▼ keys to add or subtract the extended time from the soak time. Refer to the Profile Control Page. If the extended soak value is set to '0' the Time Remaining feature is disabled.

100.3  
110.5  
rPt-Ct  
3

No Timer Option

Repeat Count

Remaining number of times the current profile is to be repeated.

Timer Option

b 1R5  
0.0

t1.E  
12:00

Current Time

Time (displayed using 24hr clock)

100.3  
110.5  
DATE  
24 JAN

Current Date

Day and Month

5.3 Alarm Acknowledge Page

5.3.1 Alarm Indications – Fig. 5.5

The definitions for alarm states (on, off or flashing) are detailed in Fig. 5.5.

5.3.2 Acknowledging Alarms

Unacknowledged alarms can be acknowledged from the faceplates on the front of the instrument in two ways:

In the **Operating Level** – by pressing the **\*** key at any frame (providing the key is programmed for this function – see Section 5.1 in the **Programming Manual**). The **\*** key acknowledges all alarms from either faceplate.

In the **Alarm Acknowledge Page** – by pressing the **▲** key – see Section 5.3.3 following.

**Note.** In the **Alarm Acknowledge Page** Channel 1 alarms can be acknowledged only from faceplate 1. Channel 2 alarms (if applicable) can be acknowledged only from faceplate 2.

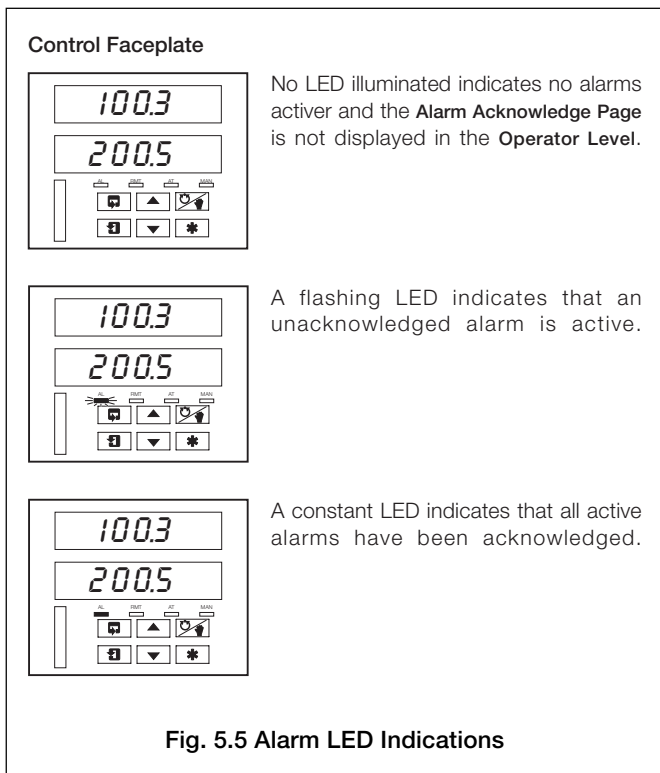

5.3.3 Using the Alarm Acknowledge Page

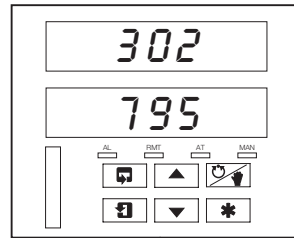

**No Alarm Active**  
No LED indicators illuminated.

Alarm Activated

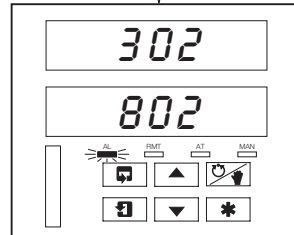

**Alarm Active**  
AL LED indicator flashing, indicating an active alarm on this channel.

Use the **☐** key to return to top of **Alarm Acknowledge Page**.

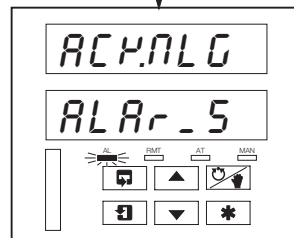

**Alarm Acknowledge Page**  
Use the **☐** key to advance to next frame.

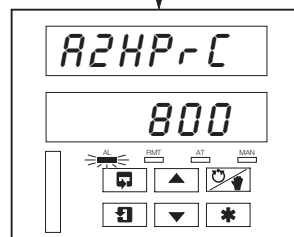

**Alarm Identity**  
**Upper display:** shows the alarm identity and type.  
**Lower Display:** shows the trip level of the alarm identified in the upper display.

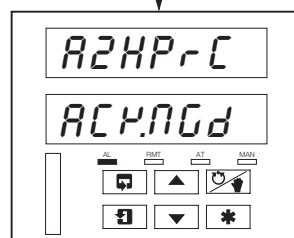

**Acknowledge Alarm**  
Use the **▲** key to acknowledge the alarm. When the alarm is acknowledged, 'ACKNGd' is displayed and a constant LED indicates the acknowledged alarm.

If there are more active alarms on the selected channel the LED continues to flash until all alarms for this channel have been acknowledged.

5.4 Totals Page Displays

This page is omitted from both faceplates if the **Totalizer Option** is not fitted. The page is also omitted from faceplate 1 if **Total 1** is set to *OFF* and from faceplate 2 if **Total 2** is set to *OFF* – refer to the **Set Up Totals Page** in the **Advanced Software Options Manual**.

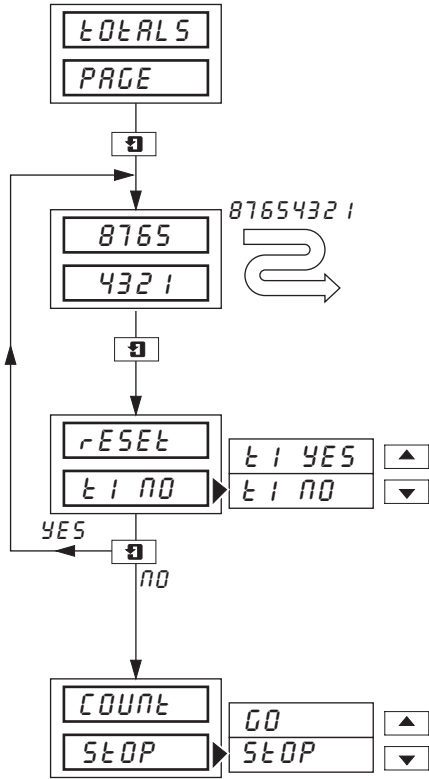

Page Header –Totals Page.

**Front Panel (Batch) Flow Total 1 (2)**

The batch flow total is calculated from process variable 1 (2).

The flow total can be reset in the next frame if **Reset Enable** in **Set Up Totals Page** is set to 'E**NbL**-y'.

**Counter Reset**

The Front (Batch) Flow Total can be reset to the **Preset Value** in **Set Up Totals Page** if required.

Select 'E**1** YES' to reset the counter ('E**1**' indicates **Flow Total 1**).

**Note.** If the Counter Reset is disabled in **Set Up Totals Page**, the counter reset frame is omitted.

**Counter Stop/Go**

Select 'GO' to start the counter or 'STOP' to stop it.

**Note.** If the Counter Stop/Go is disabled in **Set Up Totals Page**, the frame can be viewed but not altered. If a digital signal is assigned to **Totalizer Stop/Go**, an active digital signal sets the counter to **GO** and the Counter cannot be stopped from the front panel.

### 5.5 Access to Configuration Levels

A security system is used to prevent tampering with the program parameters by utilizing a Tune password and a configuration password. A Tune password can be assigned to controller faceplates giving access to that faceplates controller settings.

A Configuration password gives access to all controller settings and programming pages – refer to the **Programming Manual**.

#### 5.5.1 Security Code Page

Set the security code to the correct Tune or Configuration password using the and keys and use the key to advance to the controller settings or other programming levels (**OPERATOR, BASIC CONFIGURATION, CONTROL CONFIGURATION** and **ADVANCED CONFIGURATION**).

The passwords are programmed in the **Access Page** in the **BASIC CONFIGURATION LEVEL**.

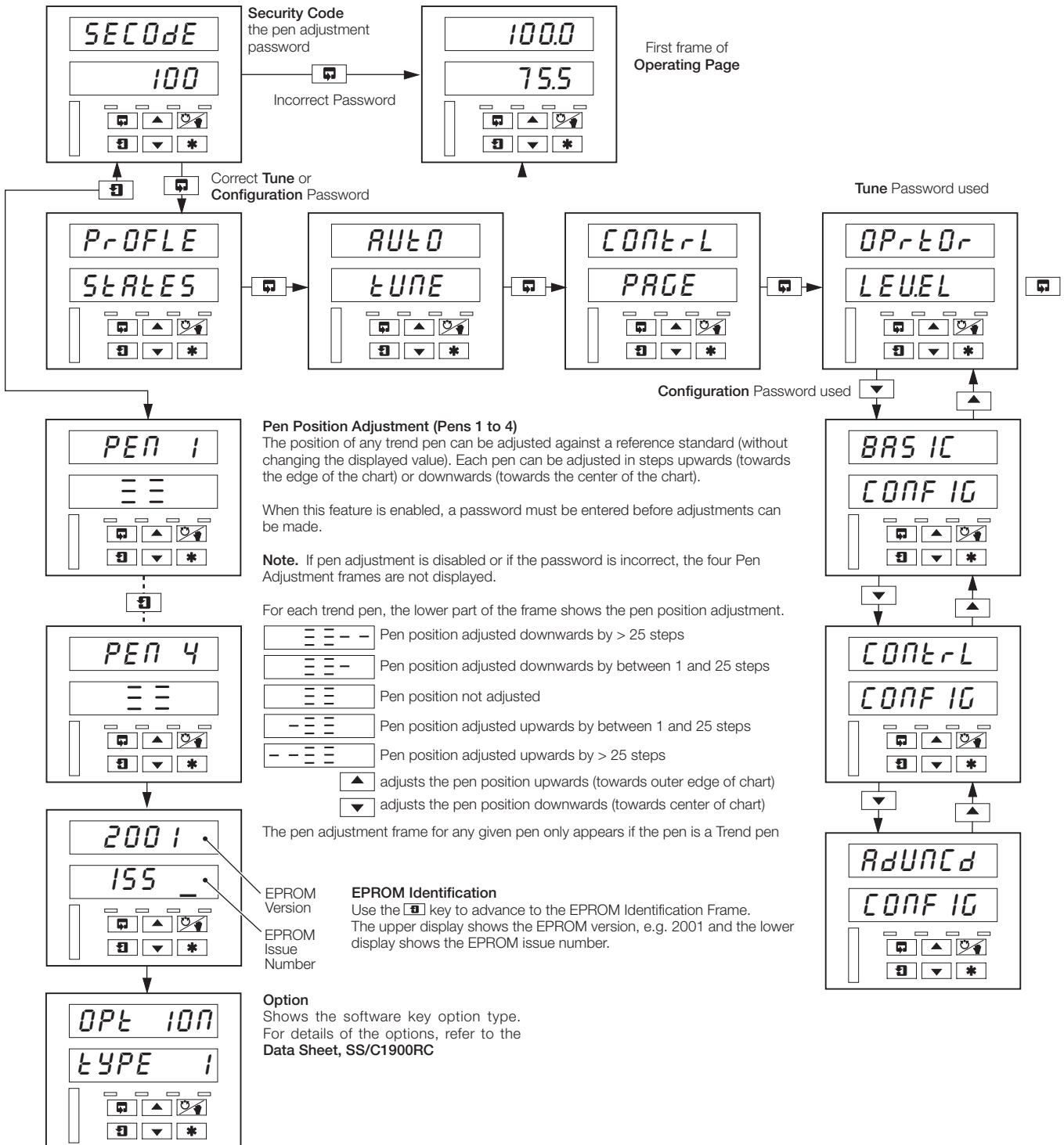

5.6 Profile States Page

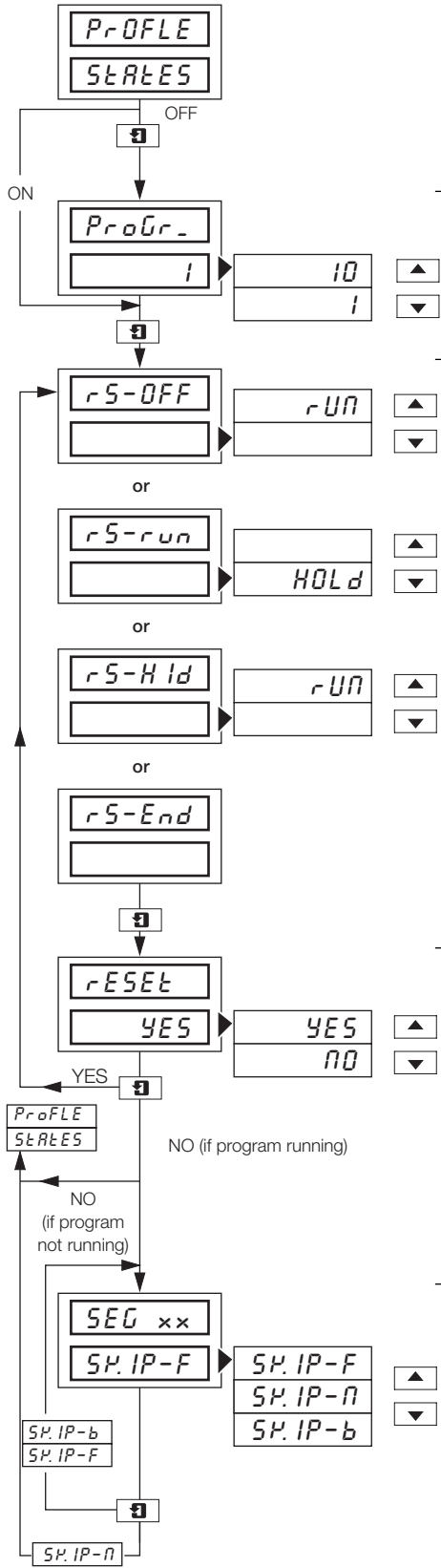

Page Header – Profile States

The **[\*]** key can be programmed to jump to this frame (Set Up Function Keys Page, **ADVANCED CONFIGURATION LEVEL**). If the key is used, the display reverts automatically to the first frame of the **Operating Page** when leaving this page.

**Program Select**

Select the program to be run (1 to 10).

**Profile Status (Ramp Soak)**

- rS-OFF/ON** – (Ramp Soak Run/Off) select *rUN* to start selected program. Press the **[\*]** key to activate.
- rS-rUN/HOLD** – (Ramp Soak Run/Hold) select *HOLD* to stop selected program at current level. Press the **[\*]** key to activate.
- rS-Hld** – (Ramp Soak Hold) program is in the hold state, either as a result of an operator hold, the controller is in manual or the holdback facility (guaranteed ramp/soak). Select run to continue running the profile if operator has stopped program. Press the **[\*]** key to activate.
- rS-Hld/END** – (Run/Hold End) the profile is completed, and the digital input assigned to the profile function is still in the 'Run' state. This frame is only displayed if a digital input is used to run and hold the profile.

**Note.** If a digital input is assigned to the run/hold function, the user is prevented from overriding the digital signal.

**Profile Reset**

If the profile is running and *YES* is selected, the profile returns to the beginning of the program and continues to run.

**Note.** To end a program, select *HOLD* at the Profile Status frame (see above) and then select *YES* at this frame. The local set point value takes the value of the first level of the selected program.

**Skip Segment**

The segment number (or *END*) is shown in the upper display.

- SP.IP-F* (skip forward) – abandon current segment and start next segment.
- SP.IP-n* (do not skip) – maintain control using current segment.
- SP.IP-b* (skip back) – return to beginning of current segment.

For multiple skip operations, the last selection (For b) is displayed for 3 seconds before reverting to *SP.IP-n*.

5.7 Auto-tuning Introduction

Information.

- On demand user-activated tuning.
- Two types of auto-tuning – initial 'Start-up' and when close to Set Point.
- Tuning for P, PI or PID control can be selected.
- Tuning for 1/4 wave damped or minimum overshoot can be selected.
- Automatic entry of calculated control terms – unless an auto-tune error occurs.
- Error and Caution messages – indicate reason for tuning problems.

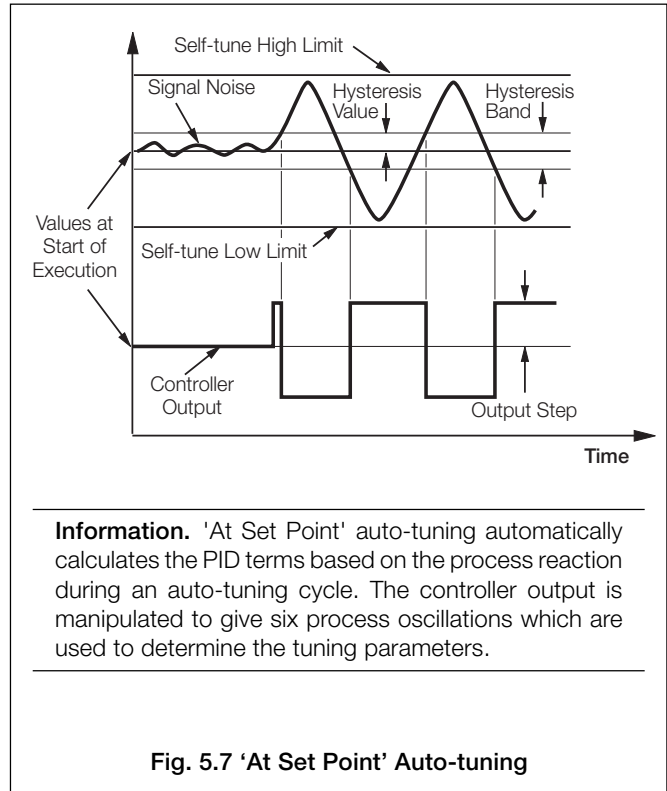
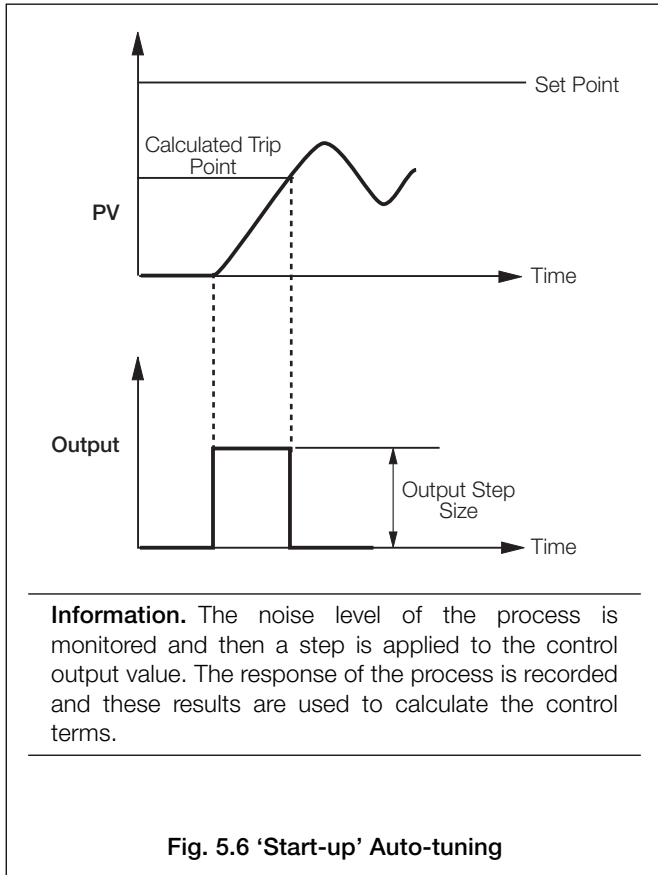

5.7.1 Auto-tuning Page

Information on Initial Conditions.

- **'Start-up' Tuning** – the controller is placed in the Manual control mode with the control output value set to give a stable process variable at least 10% of the engineering range below the control set point.
- **'At Set Point' Tuning** – may be initialized in the automatic mode but the process variable must be close to the required set point and stable. The control output must also be stable. However, for best results the Manual control mode can be used to stabilize the output and the process value. The output must be adjusted slowly to allow process response to the change, to bring the process variable to the required control set point. The closer the process is to the set point, the more effective the auto-tuning cycle.

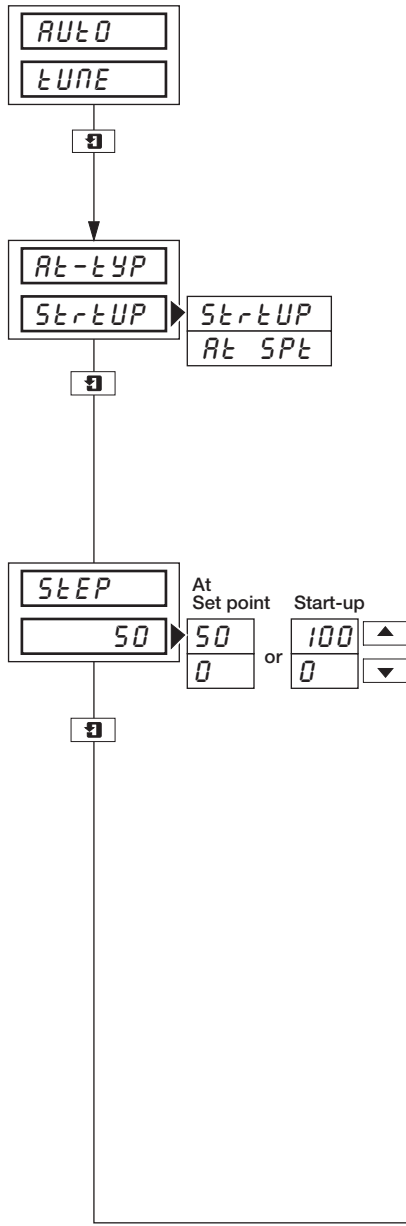

Page Header – **Auto-tune.**

The **[\*]** key can be programmed to jump to this frame (**Set Up Function Keys Page, ADVANCED CONFIGURATION LEVEL**). If the key is used, the display reverts to the first frame of the **Operating Page** on leaving this **Page**.

**Auto-tune Type**

The two tuning facilities ('**Start-up**' and '**At Set point**') are used to calculate automatically the Proportional, Integral and Derivative terms required.

'**Start-up**' tuning is used from initial start-up or when there is a large change in set point value.

'**At Set point**' tuning is used when the process is close to the required set point.

Select the auto-tune type required.

**Output Step Size**

The output step size is a percentage of the control output.

'**Start-up**' Tuning – the larger the step size used the quicker the auto-tuning process is performed, but the greater the overshoot (above the calculated trip point). If too small a step size is used the response may be too slow for the auto-tuning to operate correctly. In practice, use as large a step size as can be tolerated.

'**At Set Point**' Tuning – the controller output changes by plus and minus the output step size from its initial starting value when auto-tuning is executed. If the output step size is too large to allow this its value is reduced,

**Example** – If the controller output value = 30% and the selected step size = 50%. The step size is reduced to 30%.

The Step size should be large enough so that the amplitude of the process variable excursions are at least four times larger than the hysteresis parameter to allow the best possible response data. The output step size must be small enough to avoid crossing either of the auto-tune limits (see following frames).

Set the step size required.

Continued on next page.

...5.7.1 Auto-tuning Page

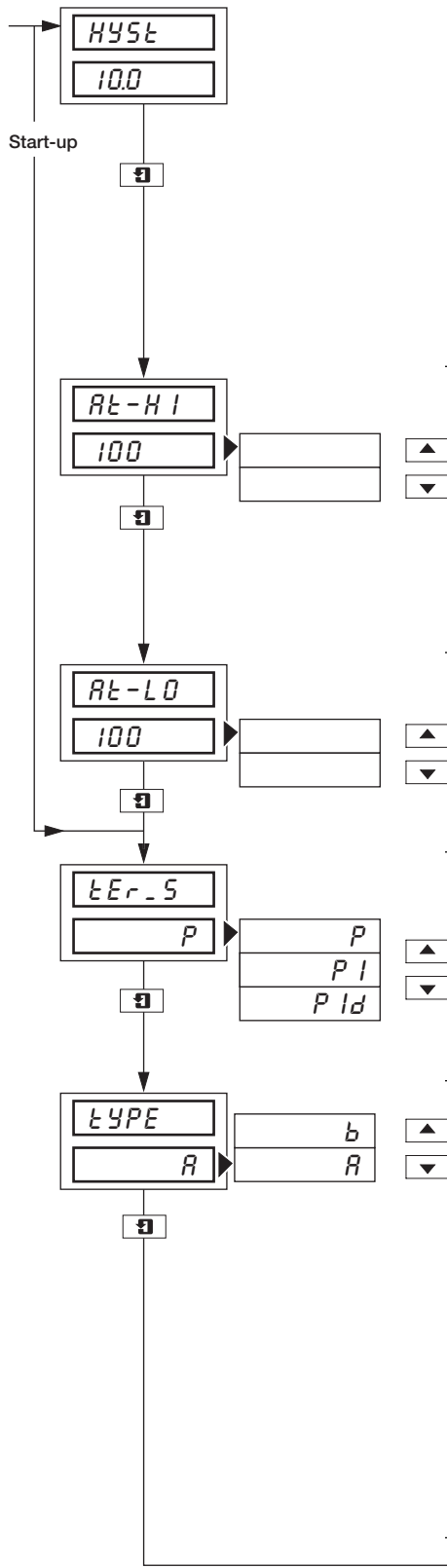

**Hysteresis Value**

The hysteresis value is entered in engineering units and is used to determine when to change the controller output value.

'At Set Point' Tuning only – when the process variable crosses the hysteresis band (plus and minus the hysteresis value), the controller output changes by plus and minus the *SEtP* value from its initial starting value. The hysteresis value should be set as small as possible but larger than the noise in the process variable signal, to allow the best possible response data.

Set the hysteresis value required (in engineering units).

**Auto-tune High Limit**

The process variable must be between the high and low limits when auto-tuning is activated. If the process value exceeds one of these, the auto-tuning cycle is shut off automatically by reverting to the manual control mode and returning the controller output to the value set when the auto-tuning was activated. The high and low values are the limits for cancelling auto-tune execution.

Set the value required (in engineering units), the decimal point is set automatically.

**Auto-tune Low Limit**

Set the value required.

**Three Term Control Parameters**

Select the Proportional, Integral and Derivative terms required.

**Control Type**

Select:

'R' for quickest response with  $\frac{1}{4}$  wave damping.

or

'B' for quickest response with minimum overshoot.

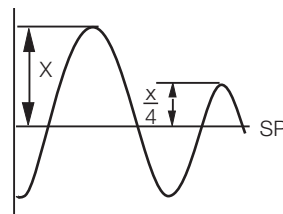

Type A –  $\frac{1}{4}$  Wave Damping

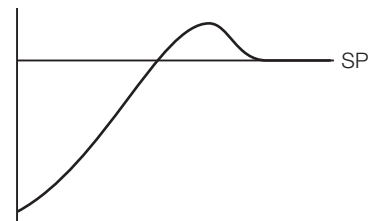

Type B – Minimum Overshoot

Continued on next page.

...5.7.1 Auto-tuning Page

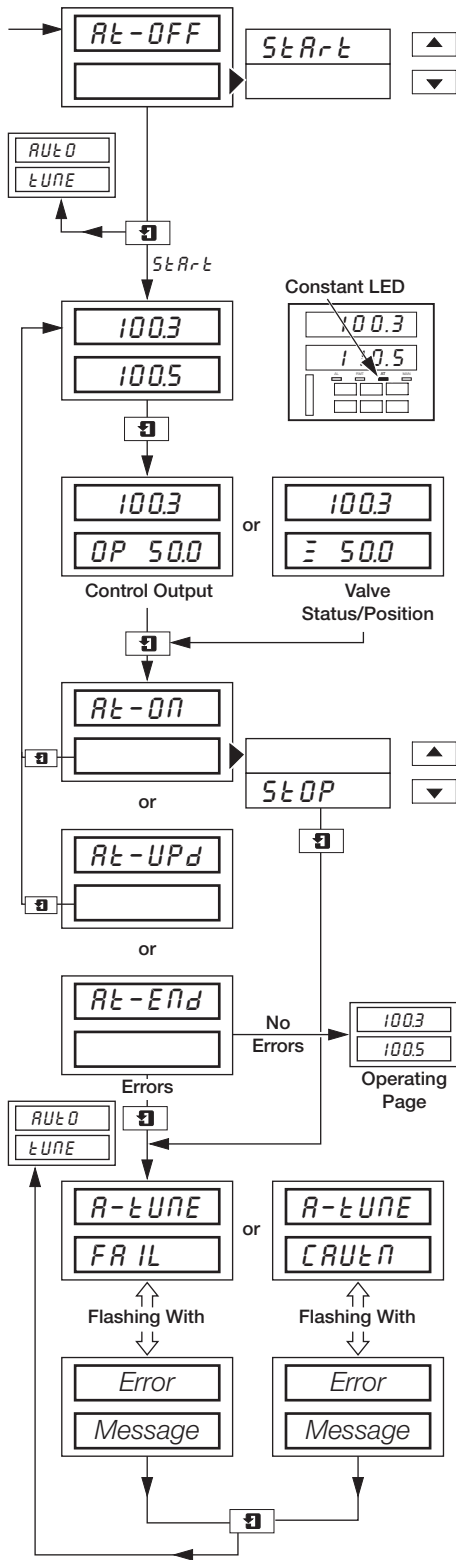

**Auto-tune Status/Enable**

Select *Start* to enable auto-tune cycle. The 'AT' (auto-tune) LED is illuminated. The time taken for completion of auto-tuning is dependent on the speed of response of the controlled process.

**Note.** If **Auto-tune** is selected it is not possible to exit the **Auto-tuning Page** until the auto-tune cycle is complete or ended by the operator.

**Process Variable** (upper display)

**Control Set Point Value** (lower display)

The set point is displayed for monitoring only and cannot be changed at this frame.

**Process Variable** (upper display)

**Control Output** (lower display)

The output value is displayed for monitoring only and cannot be changed at this frame.

**Auto-tune Status and Enable/Disable**

*At-ON* – (Auto-tune On) auto-tuning can be switched off by pressing the key to select *Stop* and then pressing the key.

*At-UPd* – (Auto-tune Update) the auto-tune cycle is complete and the calculated terms are being written to memory.

*At-END* – (Auto-tune End) the auto-tune cycle is complete. If no failures occur during the cycle, the calculated values are loaded into memory as new control terms and the instrument returns automatically to the **Operating Page**. If failures or cautions occur during auto-tuning, error messages are displayed in the next frame.

**Auto-tune Error Messages**

If a **Failure** occurs the controller reverts to the manual control mode, the old control terms are retained and the auto-tune LED flashes.

If a **Caution** occurs the calculated control terms are loaded into memory and control continues in the automatic mode. Any errors are acknowledged when exiting this frame and the auto-tune LED flashes.

For an explanation of error messages – refer to Table 5.1 overleaf.

5.8 Auto-tune Diagnostic Messages

Message	Explanation	Action
<p>The diagram shows a box with 'A-TUNE' and 'CAUTION' on the left. An arrow labeled 'Flashing with' points to a series of boxes: 'Pb-INt', 'HI-Lt', 'SP tOO', 'CLOSE', 'INCrSE', and 'StEP'. The boxes are arranged in three groups, with 'or' text between them.</p>	<p>The auto-tune process has selected a proportional band or integral action time above the high limits of these parameters so the high value has been used.</p> <p>With 'Start-up' tuning, although the control set point was &gt;10% of the display range above the process variable, it may still be too close to allow the auto-tune facility to determine the process characteristics accurately.</p> <p>With 'At Set Point' tuning, the ratio of process oscillation to hysteresis value is too small for best results.</p>	<p>Because of the process characteristics, re-trying the auto-tuning process is unlikely to improve the calculated control parameters.</p> <p>If desired, allow the process variable to move further below the control set point (by changing the control output in the manual control mode) before re-trying 'Start-up' auto-tuning. Alternatively, use the 'At Set Point' auto-tune facility.</p> <p>Restart auto-tune with a larger output step size or a smaller hysteresis value. Hysteresis must be at least equal to and preferably greater than process noise.</p>
<p>The diagram shows a box with 'A-TUNE' and 'FAIL' on the left. An arrow labeled 'Flashing with' points to a series of boxes: 'SLD', 'PrCESS', 'NOISY', 'SP tOO', 'CLOSE', 'INPUT', 'Ll. lEtS', 'USER', 'Abort', 'UPdRtE', 'Error', 't l-E', and 'OUE'. The boxes are arranged in seven groups, with 'or' text between them.</p>	<p>The process is too slow for the auto tuning to work correctly.</p> <p>The process variable signal is excessively 'noisy'.</p> <p>With 'Start-up' tuning, the process variable is &lt;10% of the display range, below the control set point.</p> <p>The input failure level has been exceeded, possibly due to a broken sensors or the process has exceeded one of the auto-tune limits.</p> <p>Operator has stopped auto-tune process.</p> <p>Non-volatile memory failure while updating control parameters.</p> <p>The auto-tune process is too slow.</p>	<p>If possible, use a larger output step value.</p> <p>Check input wiring to try and find the source of the problem. If the process is changing rapidly then allow it to settle before re-trying the auto-tuning process.</p> <p>Allow the process variable to move further below the control set point before re-trying 'Start-up' auto-tuning. Alternatively, use the 'At Set Point' auto-tune facility.</p> <p>Check input wiring to find the cause of the failure or restart auto-tuning with a smaller output step size.</p> <p>None.</p> <p>Re-try auto-tune, if error persists contact local Service Organization.</p> <p>If possible, use a larger output step value. Otherwise, for 'Start-up' auto-tuning, move the process closer to the set point, or, for 'At Set Point' auto-tuning, reduce the hysteresis value.</p>

Table 5.1 Auto-tuning Error and Diagnostic Messages

5.9 Introduction to Standard Control

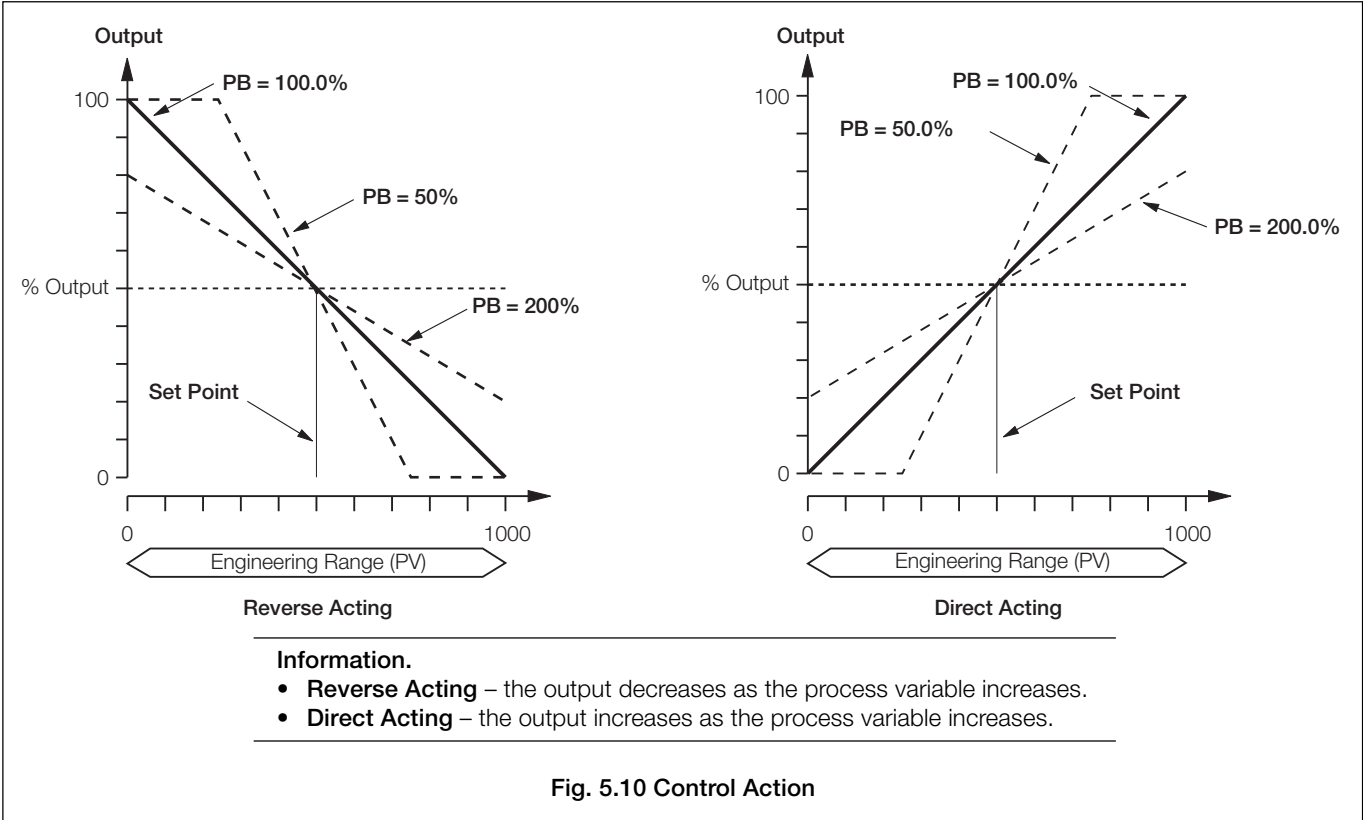
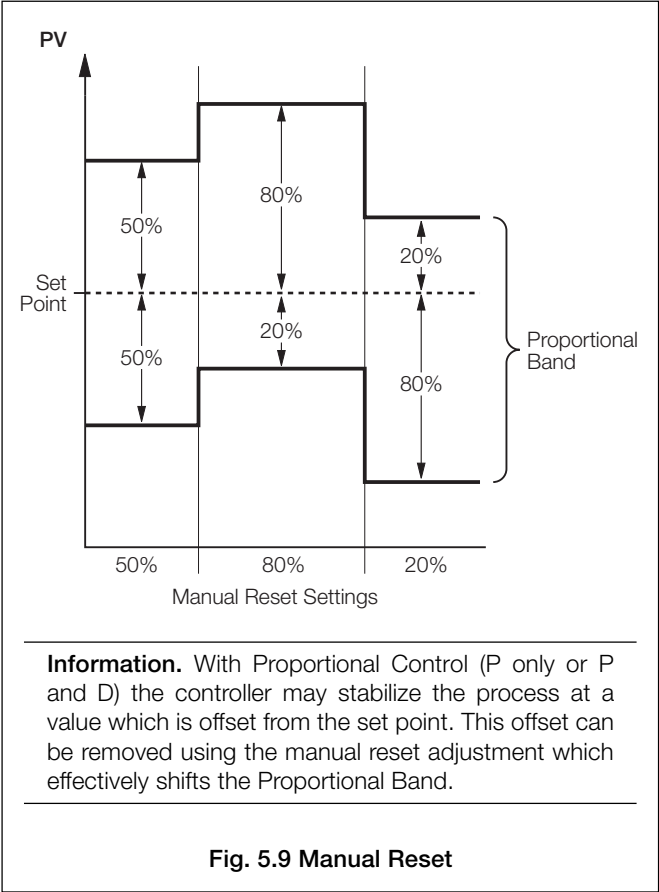
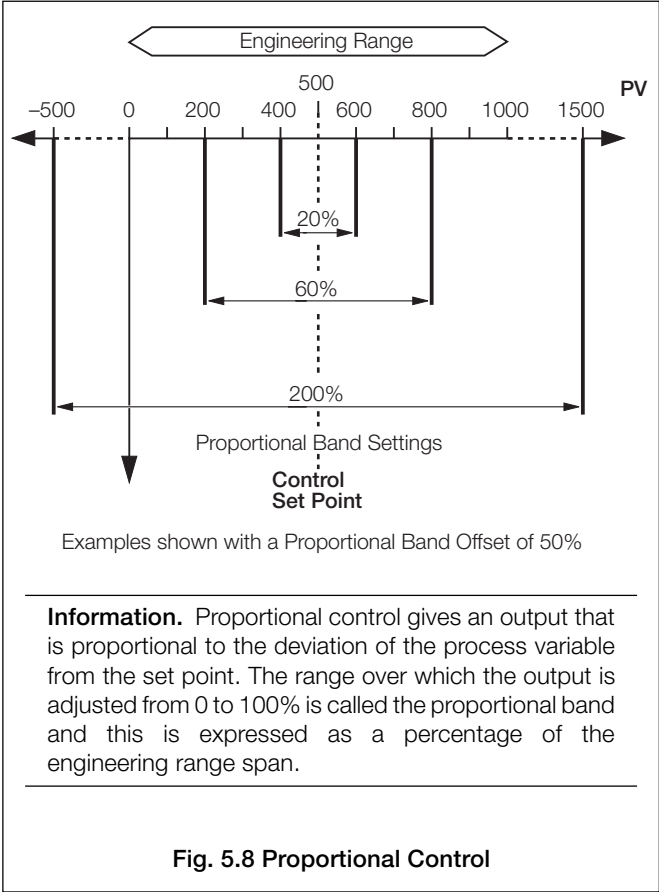

...5.9 Introduction to Standard Control

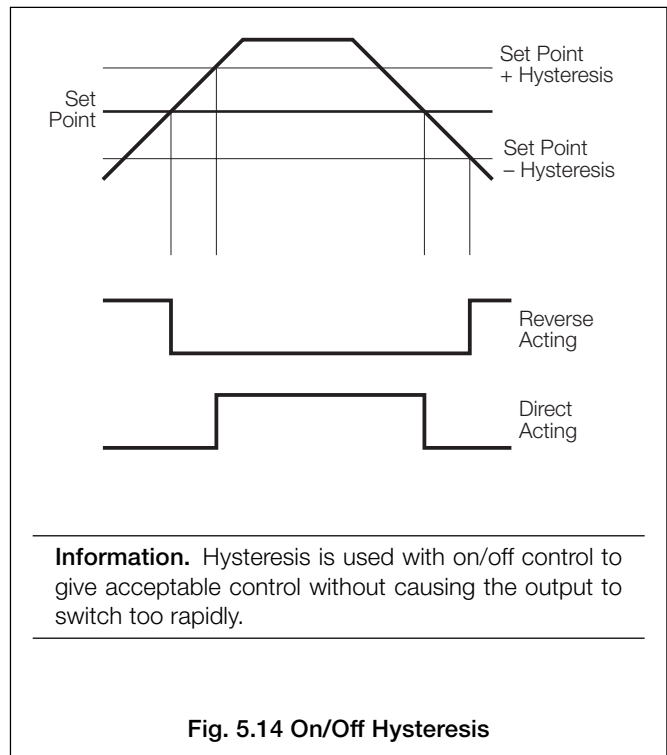
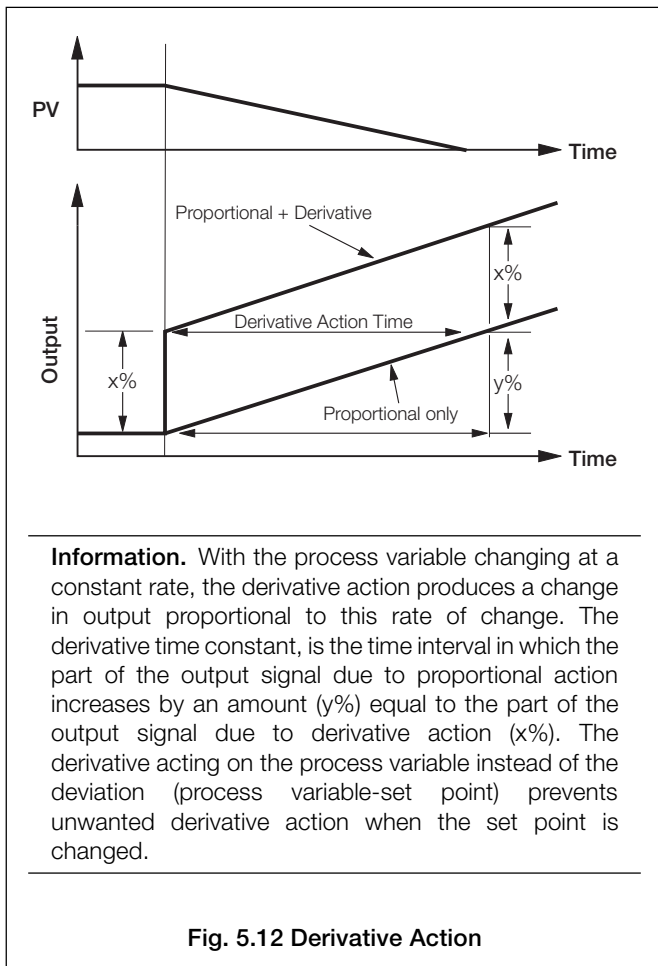
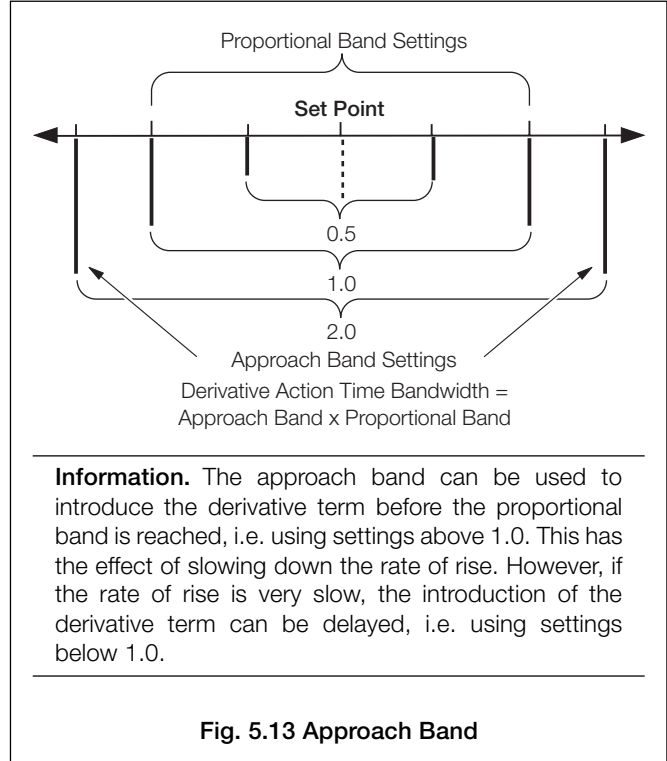
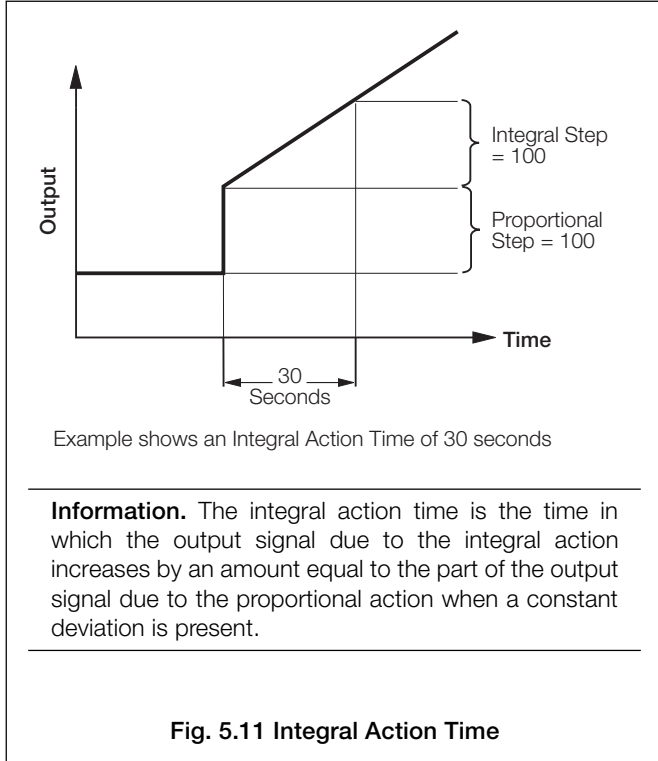

...5.9 Introduction to Standard Control

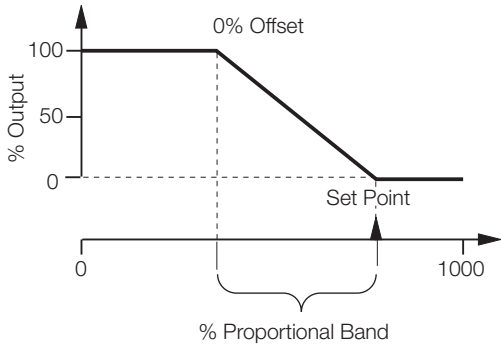
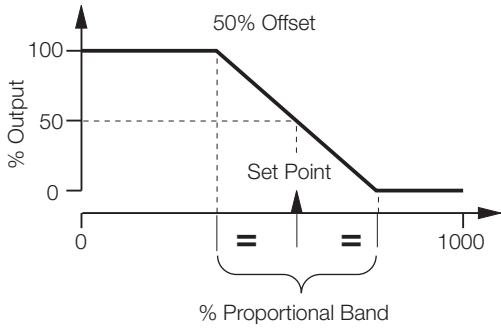

Reverse Acting

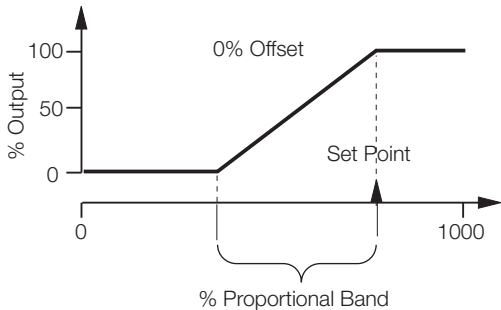
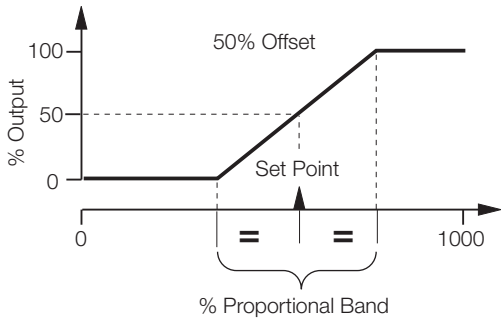

Direct Acting

**Information.** A control offset of 0% allows early control of the output and reduces the overshoot on initial start-up. Control offset is set in the **Control Page** in the **CONTROL CONFIGURATION LEVEL, Programming Guide.**

Fig. 5.15 Offset

Example shows a Cycle Time of 20 seconds

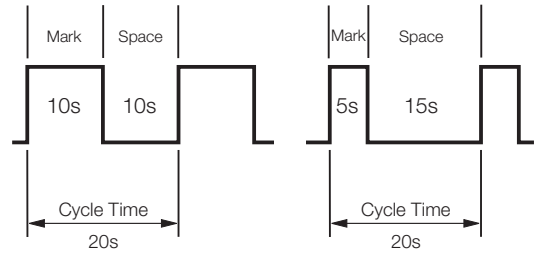

$$\% \text{ Output} = \frac{10}{20} \times 100$$

$$\% \text{ Output} = 50\%$$

$$\% \text{ Output} = \frac{5}{20} \times 100$$

$$\% \text{ Output} = 25\%$$

$$\% \text{ Output} = \frac{\text{On Time}}{\text{Cycle Time}} \times 100$$

**Information.** The cycle time is the period of oscillation (in seconds) of the output for time proportioning mark/space ratio control. The optimum value is a function of the process characteristics.

Fig. 5.16 Cycle Time

**Information.**

- **On/Off Control** – use for applications where precise control is not required or where frequent switching of a contactor using time proportioning control causes premature wear.
- **Proportional Control** – use where:
  - cycling action of on/off control is unacceptable
  - load changes are small or infrequent
  - offset can be tolerated or eliminated using manual reset.
- **Integral Action** – introduce to the control system:
  - to eliminate offset automatically
  - if set point or load changes frequently
- **Derivative Action** – introduce to the control system:
  - to enable faster approach to the set point
  - (by enabling use of a smaller proportional band) to minimize overshoot.

...5.9 Introduction to Standard Control

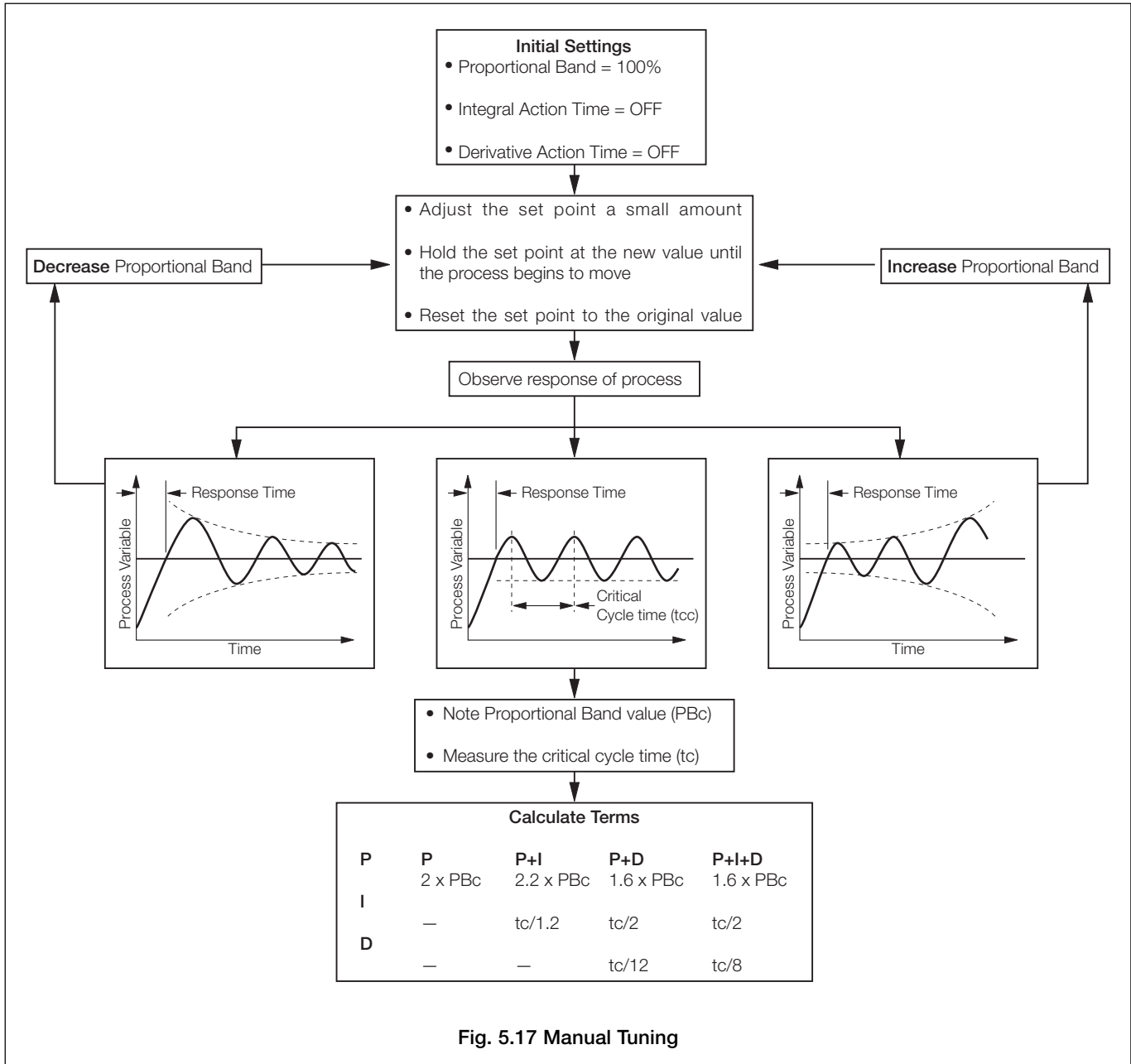

Fig. 5.17 Manual Tuning

...5.9 Introduction to Standard Control

Response	Contributions	Effect Of Response Settings		
		Too High	Too Low	
<b>On/Off Hysteresis</b>	Helps to prevent rapid switching of output	Process swings too far above and below set point	Output switches too rapidly	
<b>Proportional Band</b>	Stable control with the minimum offset and minimum period of oscillation consistent with stability.	<ul style="list-style-type: none"> <li>• More stable</li> <li>• Longer period</li> <li>• Larger offset</li> </ul>	Stability decreases	
<b>Integral</b>	Eliminates offset between Process and Set Point.	Time for variable to return to set point increases	<ul style="list-style-type: none"> <li>• Stability decreases</li> <li>• Period of oscillation increases</li> </ul>	
<b>Derivative</b>	<p>Increases stability, permitting smaller proportional band and larger integral action times to be used.</p> <p>Reduces height of first peak.</p> <p>Reduces period of oscillation.</p>	<ul style="list-style-type: none"> <li>• Stability decreases</li> <li>• Process noise is amplified</li> </ul>	Maximum contribution not realized	

Table 5.2 Effect of Control Responses on Processes

5.9.1 Control Page (Standard Control)

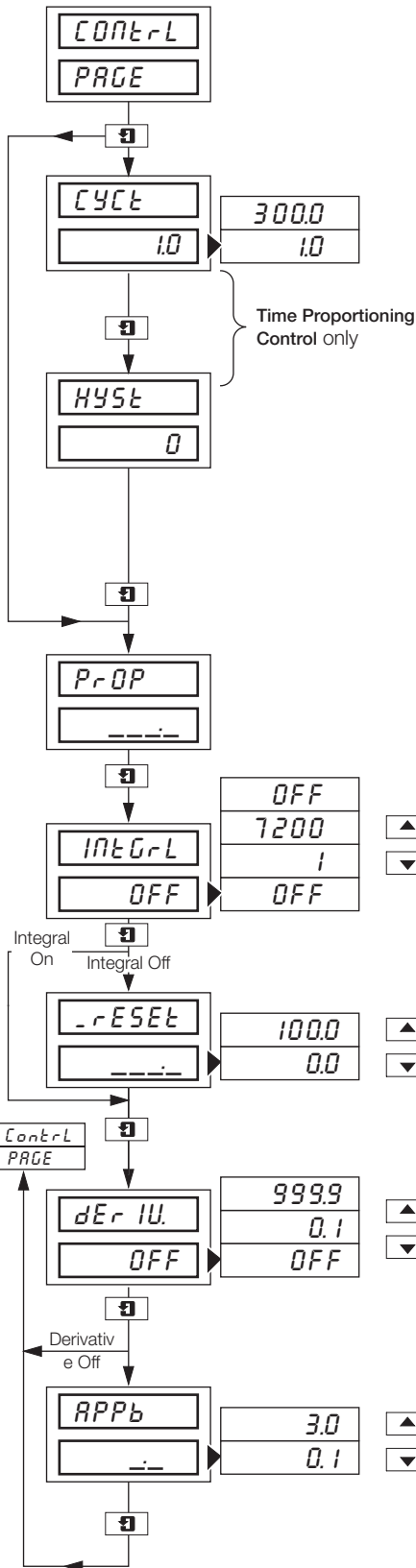

Page Header – **Control Page**

**Cycle Time** (applicable only for control using relay output)  
This setting can be ignored for analog control outputs.

Set the required cycle time for time proportioning control, from 1.0 to 300.0 in 0.1 second increments (300 seconds = 5 minutes) – see Fig. 5.16 on page 27.

**Hysteresis** (applicable only for control using relay output)  
This setting can be ignored for analogue control outputs.

The hysteresis is operational above or below (depending on the control action, direct or reverse) the set point and is only applicable for ON/OFF control – see Fig. 5.14 on page 26.

Set the hysteresis value required for on/off control in engineering units (between 0 and 10% of engineering range span).

**Proportional Band**

Set the proportional band value required, between 0.1 and 999.9% in 0.1% increments.

**Integral Action Time**

Set the required time between 1 and 7200 in 1 second increments (7200 seconds = 120 minutes). 'OFF' is selected above 7200 or below 1.

**Manual Reset**

Set the required proportional band offset on the lower display, between 0.0 and 100.0% of the engineering range span in 0.1% increments.

**Derivative Action Time**

Set the required time between 0.1 and 999.9 in 0.1 second increments (999.9 seconds = 16.67 minutes). 'OFF' is selected below 0.1.

**Approach Band**

Set the required value between 0.1 and 3.0 in 0.1 increments. (Set 1.0 initially).

## 5.10 Introduction to Heat/Cool Control

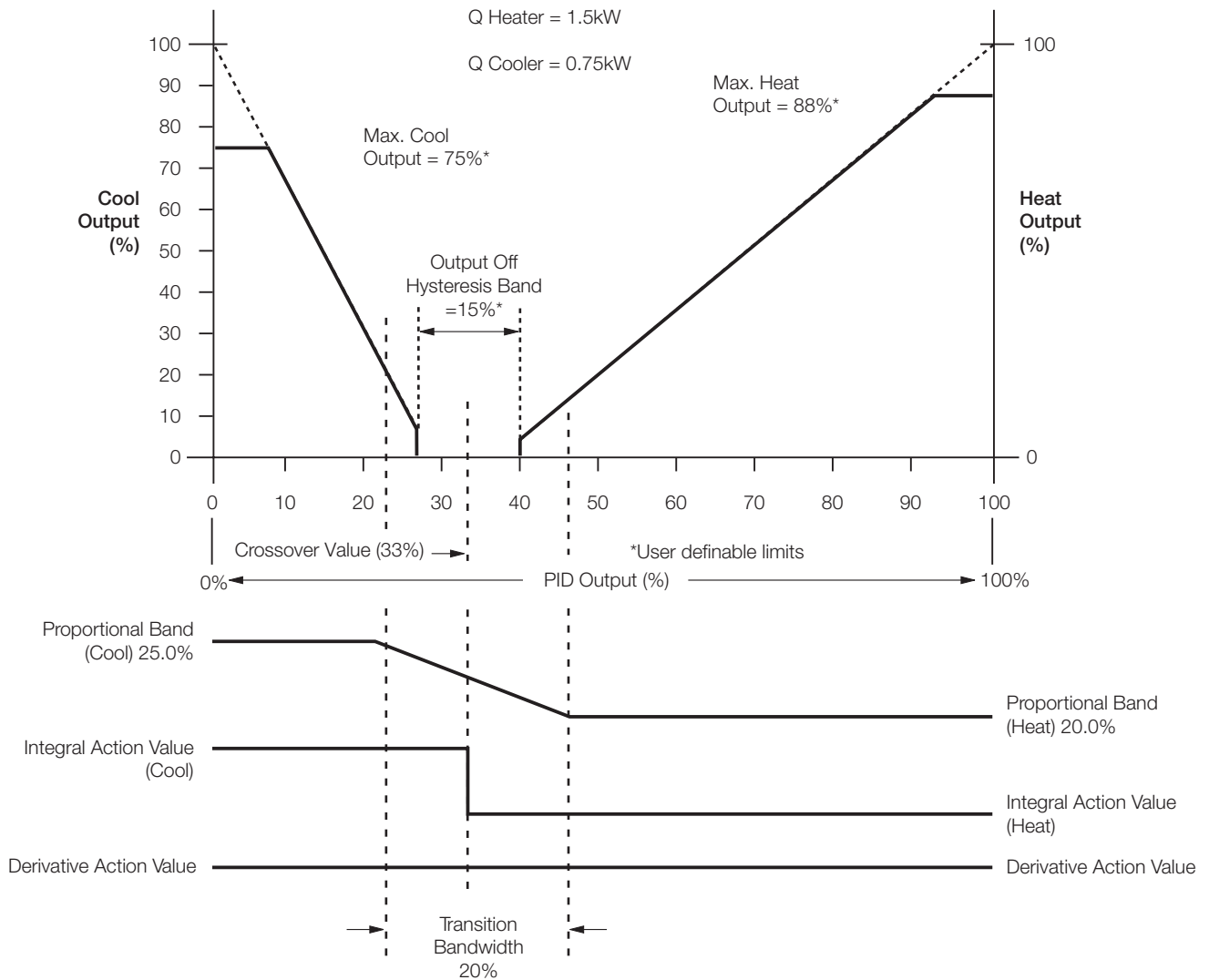

**Note.** Refer to Sections 5.10.2 and 5.10.3 for Crossover Value and Transition Bandwidth Value examples.

**Information.**

- **PID Output** – is the output value calculated by the controller. The output is divided into two different control elements one for raising the product temperature (heat output) and one for lowering the product temperature (cool output).
- **Transition Bandwidth** – used to transfer smoothly from one set of control terms to the other.
- **Crossover Value** – defines the changeover point between heat output active and cool output active. The crossover value is also the centre of the transition and off hysteresis bands.
- **Output Off Hysteresis Band** – for the majority of applications Outputs 1 and 2 have opposing control actions i.e. one is direct acting and the other is reverse. In this configuration both outputs are at 0% within the off hysteresis band. The band setting is used to prevent oscillation of control changes.
- **Heat/Cool Outputs** – refer to **PID Output**, above.

**Fig. 5.18 Heat/Cool Control – Principle of Operation**

5.10.1 Control Page (Heat/Cool Control)

Page Header – Control Page

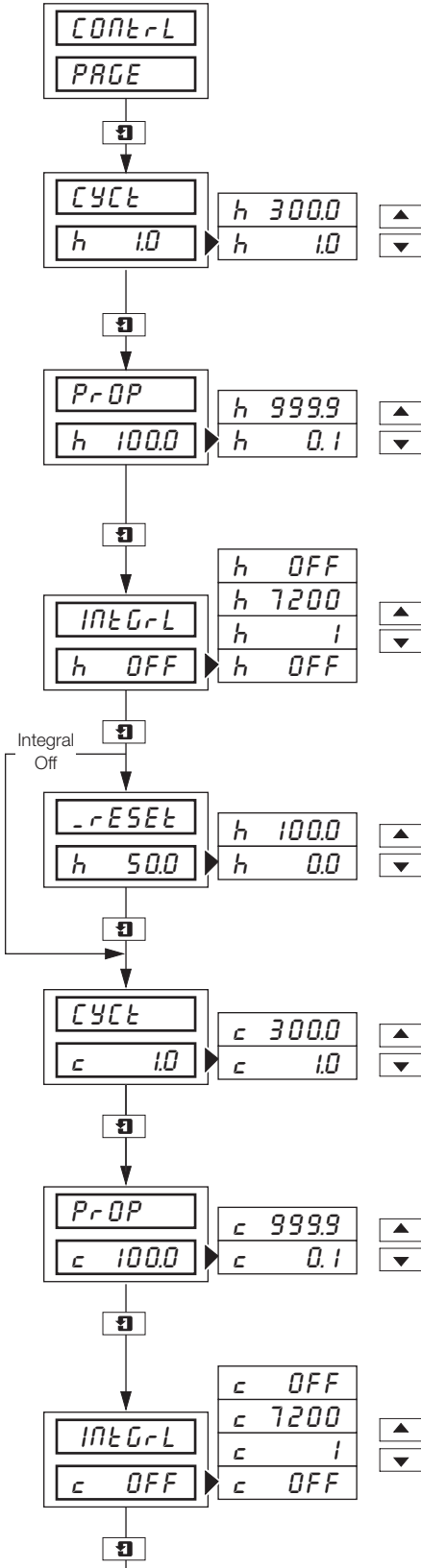

**Cycle Time (heat output)**

This setting can be ignored for analog control outputs.

Set the required cycle time for time proportioning control, from 1.0 to 300.0 in 0.1 second increments (300 seconds = 5 minutes).

**Proportional Band (heat output)**

Set the proportional band value required, between 0.1 and 999.9% in 0.1% increments.

**Integral Action Time (heat output)**

Set the required time between 1 and 7200 in 1 second increments (7200 seconds = 120 minutes). 'OFF' is selected below 1 and above 7200.

**Manual Reset (heat output)**

Set the required proportional band offset on the lower display, between 0.0 and 100.0% of the engineering range span in 0.1% increments.

**Cycle Time (cool output)**

This setting can be ignored for analog control outputs.

Set the required cycle time for time proportioning control, from 1.0 to 300.0 in 0.1 second increments (300 seconds = 5 minutes).

**Proportional Band (cool output)**

Set the proportional band value required, between 0.1 and 999.9% in 0.1% increments.

**Integral Action Time (cool output)**

Set the required time between 1 and 7200 in 1 second increments (7200 seconds = 120 minutes). 'OFF' is selected below 1 and above 7200.

Continued on next page.

...5.10.1 Control Page (Heat/Cool Control)

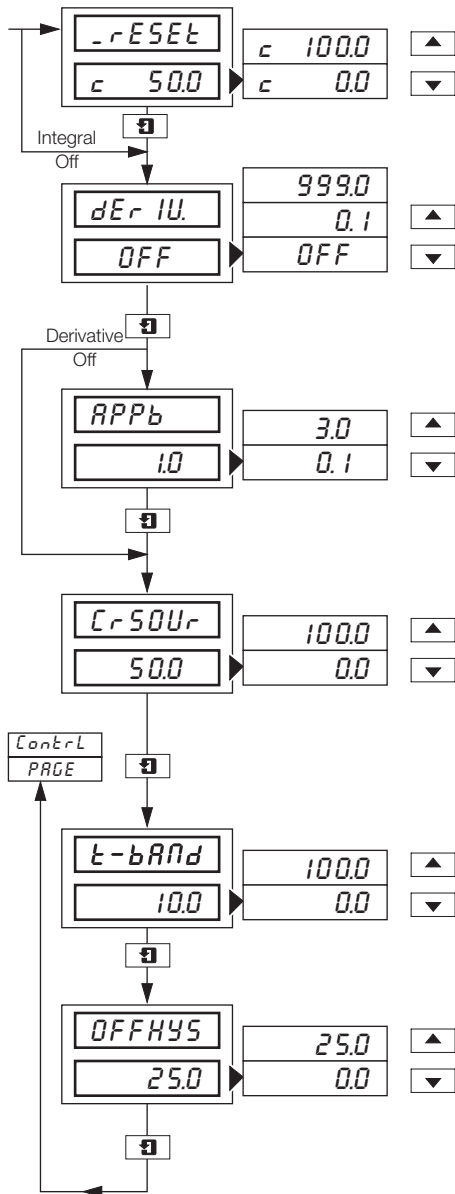

**Manual Reset (cool output)**  
Set the required proportional band offset, between 0.0 and 100.0% of the engineering range span in 0.1% increments.

**Derivative Action Time**  
Set the required time between 0.1 and 999.9 in 0.1 second increments (999.9 seconds = 16.67 minutes). 'OFF' is selected below 0.1.

**Approach Band**  
Set the required value between 0.1 and 3.0 in 0.1 increments. (Set 1.0 initially).

**Crossover Output Value**  
Set the required value between 0.0 and 100.0% of the PID output, in 0.1% increments – see Section 5.10.2.

**Transition Bandwidth**  
Set the required value between 0.0 and 100.0% of the PID output, in 0.1% increments – see Section 5.10.3.

**Output Off Hysteresis Band**  
Set the required value which prevents oscillation of control changes, between 0.0 and 25.0% of the PID output, in 0.1% increments.

**5.10.2 Calculating the Crossover Value – Fig. 5.18**

The crossover value is calculated from the expression:

$$\text{Crossover Value} = \frac{100}{Gh/Gc + 1}$$

Where Gh/Gc is the ratio of the two output driver gains.

The most common method for determining the Gh/Gc term is by using 'nameplate' values from the heat/cool device(s).

If a heat/cool application can produce a maximum of 1.5kW and absorb 0.75kW:

$$\text{Output Gain Ratio} = \frac{1.5}{0.75} = 2$$

$$\text{Crossover Value} = \frac{100}{2 + 1} = 33.3\%$$

**5.10.3 Calculating the Transition Bandwidth Value – Fig 5.18**

The Transition Bandwidth is the percentage difference of the proportional band settings.

**Example** – if the proportional band settings for the heat output is 20% and for the cool output is 25%:

$$\text{Transition Bandwidth (\%)} = \frac{25 - 20}{25} \times 100$$

$$\text{Transition Bandwidth} = 20\%$$

If the proportional band settings for both outputs are equal, the bandwidth is 0%. As a general rule, the Transition Bandwidth should not exceed 30%.

## 6 RECORD OPERATION

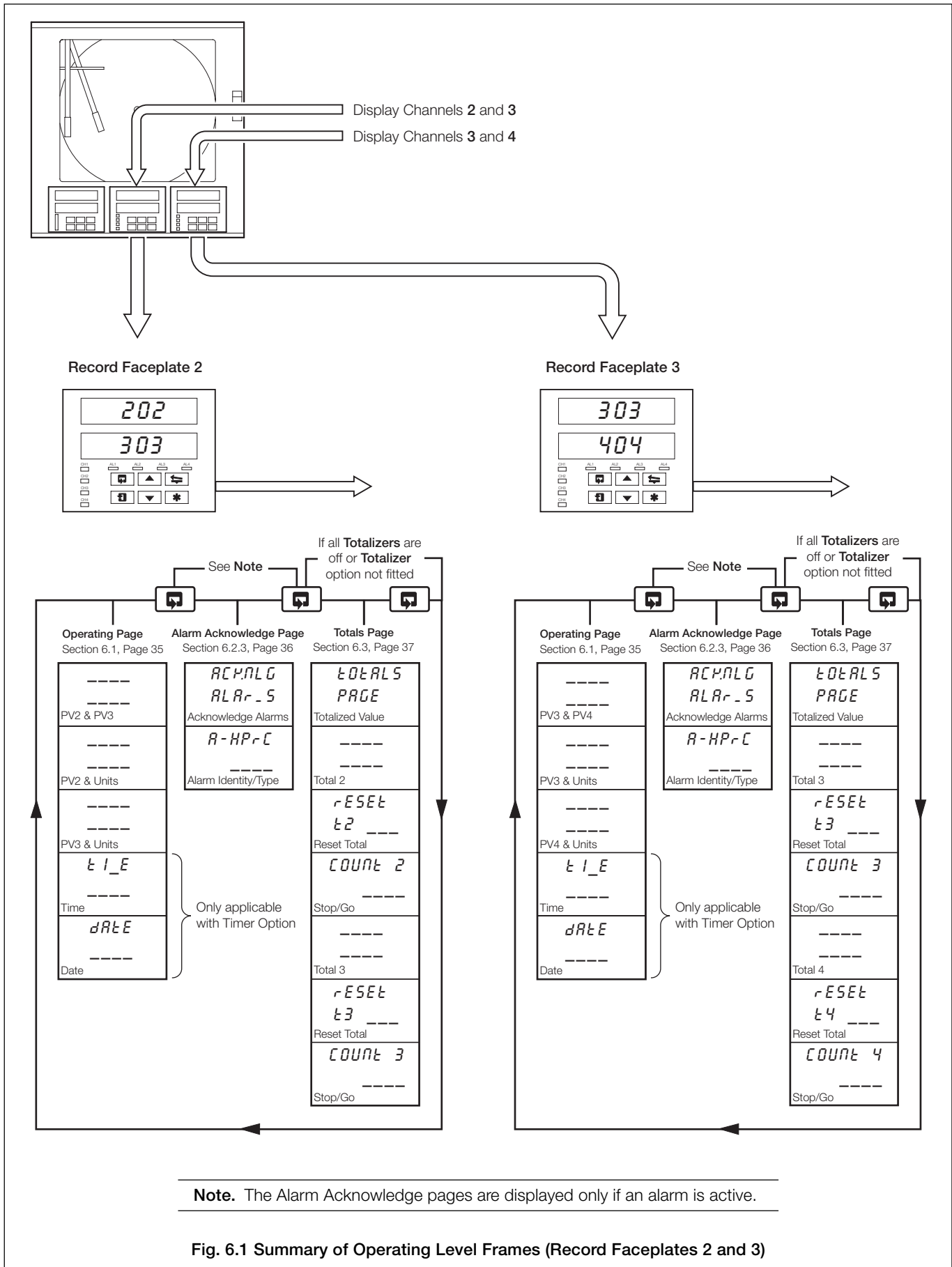

6.1 Operating Page Displays

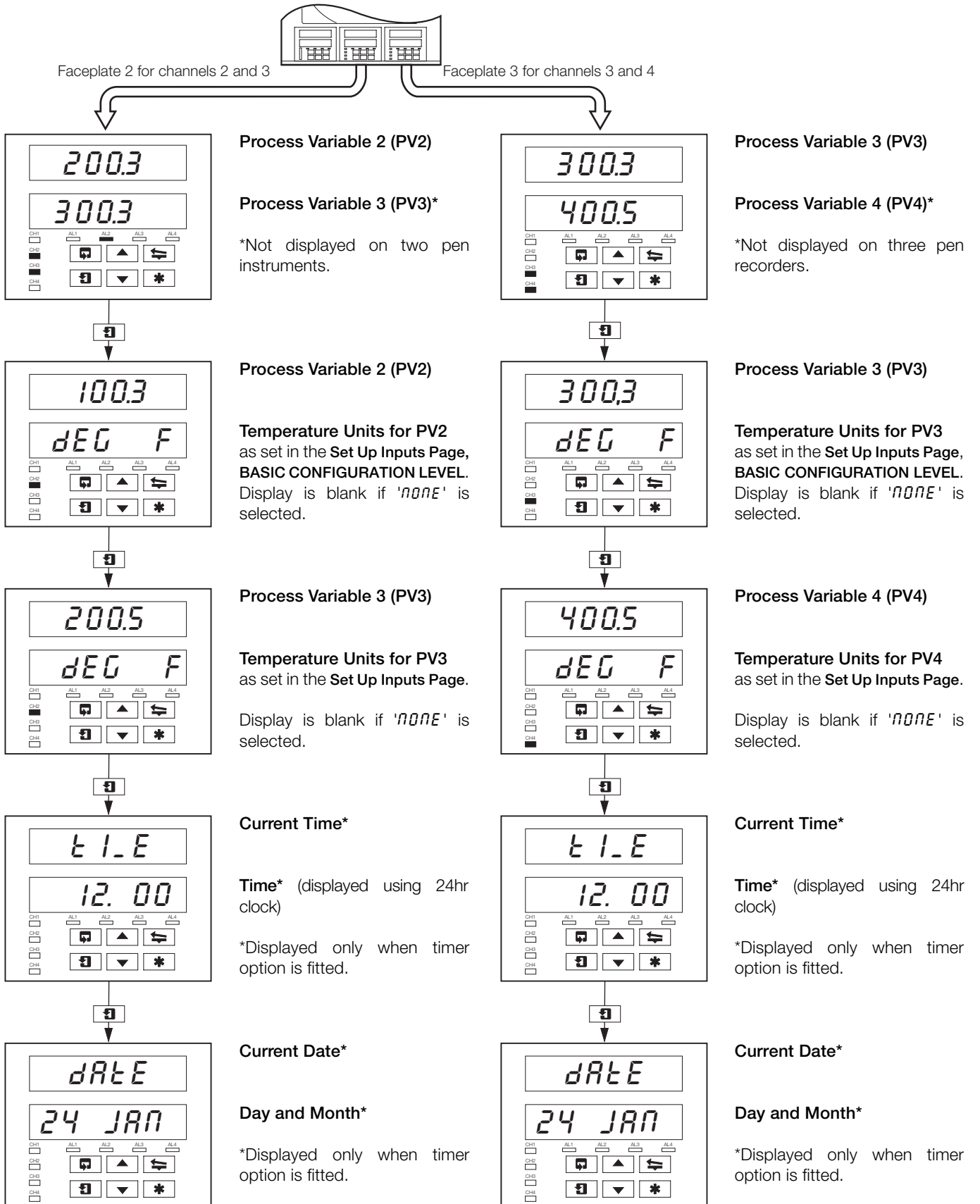

## 6.2 Alarm Acknowledge Page

### 6.2.1 Alarm Indications – Fig. 6.2

The definitions for alarm states (on, off or flashing) are detailed in Fig. 6.2.

### 6.2.2 Acknowledging Alarms

Unacknowledged alarms can be acknowledged from the faceplate controls on the front panel in two ways:

In the **Operating Level** – by pressing the **[\*]** key at any frame (providing the key is programmed for this function – see Section 5.1 in the **Programming Manual**). The **[\*]** key acknowledges all alarms from either faceplate.

In the **Alarm Acknowledge Page** – by pressing the **[▲]** key – see Section 6.2.3 following.

**Note.** In the **Alarm Acknowledge Page** Channel 2 and 3 alarms can be acknowledged only from faceplate 2. Channel 3 and 4 alarms (if applicable) can be acknowledged only from faceplate 3.

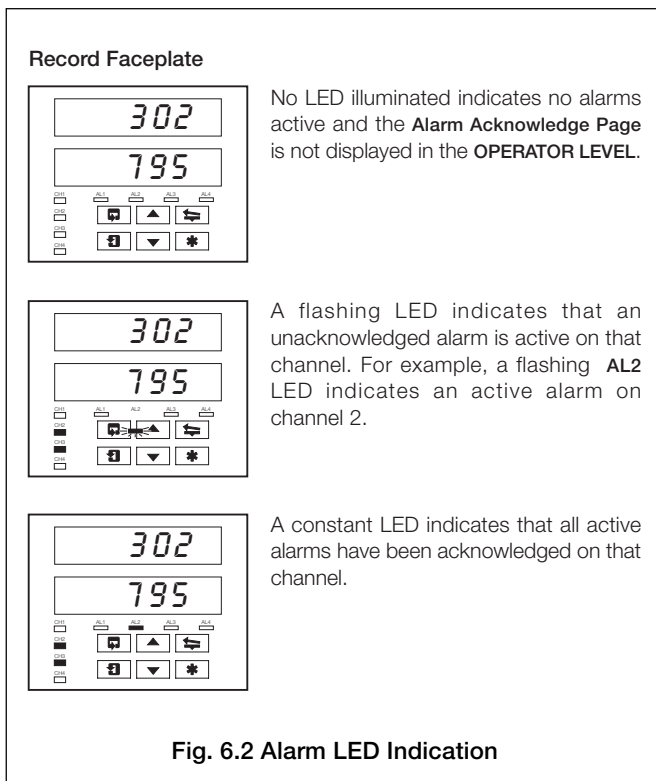

### 6.2.3 Using the Alarm Acknowledge Page

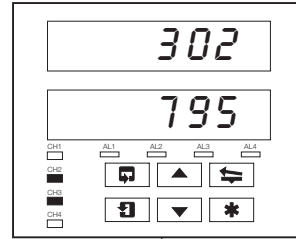

**No Alarm Active**  
No LED indicators illuminated.

Alarm Activated

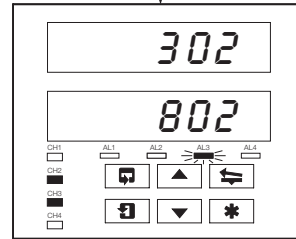

**Alarm Active**  
**AL3** LED indicator flashing, indicating an active alarm on channel 3.

Use **[□]** key to return to top of **Alarm Acknowledge Page**.

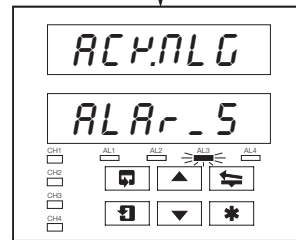

**Alarm Acknowledge Page**  
Use the **[□]** key to advance to next frame.

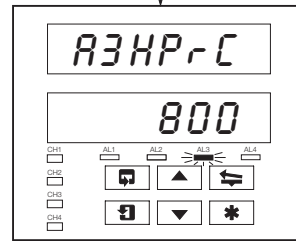

**Alarm Identity**  
**Upper display:** shows the alarm identity and type.

**Lower Display:** shows the trip level of the alarm identified in the upper display.

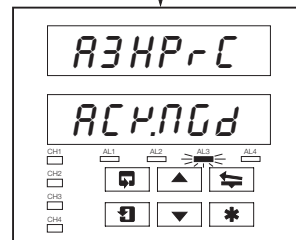

**Acknowledge Alarm**  
Use the **[▲]** key to acknowledge the alarm. When the alarm is acknowledged, 'ACKNGd' is displayed and a constant LED indicates the acknowledged alarm.

If there are more active alarms on channel 3 the LED continues to flash until all alarms for that channel have been acknowledged.

### 6.3 Totals Page Displays

This page is omitted from both faceplates if the **Totalizer Option** is not fitted. The page is also omitted from faceplate 2 if both Totals 2 and 3 are set to *OFF* and from faceplate 3 if both Totals 3 and 4 are set to *OFF* – refer to the **Set Up Totals Page** in the **Advanced Software Options Manual**.

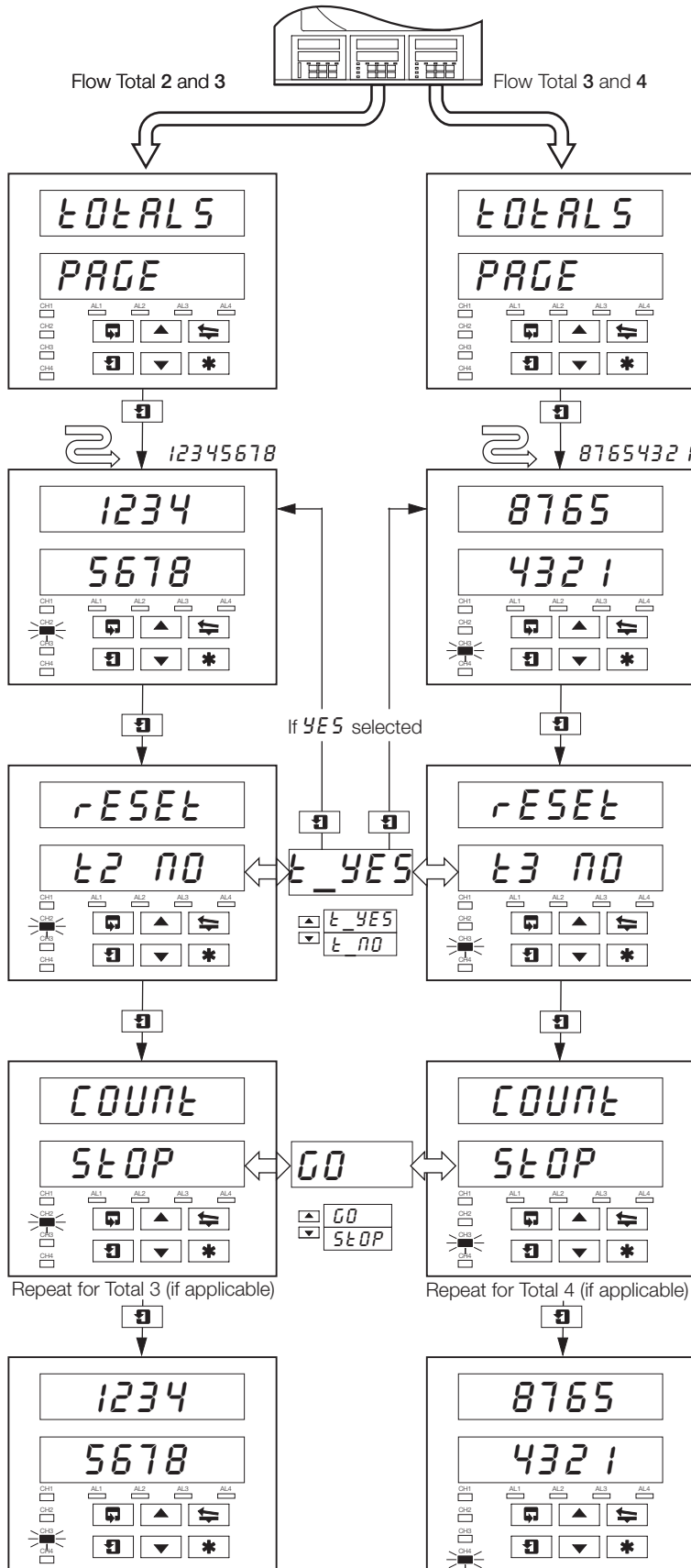

#### Front Panel (Batch) Flow Total 2 (3)

The batch flow total is calculated from process variable 2 (3).

The flashing channel LED indicates the flow total displayed.

**Example** – a flashing channel 2 LED indicates **Flow Total 2** parameters displayed.

#### Counter Reset

The Front (Batch) Flow Total can be reset to the **Preset Value** in **Set Up Totals Page** if **Reset Enable** in **Set Up Totals Page** is set to *'ENBL-Y'*.

Select *'t2 YES'* to reset the counter (*'t2'* indicates **Flow Total 2**).

**Note.** If the Counter Reset is disabled in **Set Up Totals Page**, the counter reset frame is omitted.

#### Counter Stop/Go

Select *'GO'* to start the counter or *'STOP'* to stop it.

**Note.** If the Counter Stop/Go is disabled in **Set Up Totals Page**, the frame can be viewed but not altered. If a digital signal is assigned to the **Totalizer Stop/Go source**, an active digital signal sets the counter to *GO* and the Counter cannot be stopped from the front panel.

#### Front Panel (Batch) Flow Total 3 (4)

Repeat the above procedure for **Flow Total 3 (4)**.

**Note.** The number of totalizers is dependent on the number of pens fitted to the instrument e.g. a 3 pen instrument has 3 totalizers.

## 7 SIMPLE FAULT FINDING

Symptom	Possible Cause	Action
Does not power up	<ul style="list-style-type: none"> <li>a) Internal fuse (if fitted) is blown</li> <li>b) Internal power switch (if fitted) is OFF</li> <li>c) Power supply connections are incorrect</li> </ul>	<ul style="list-style-type: none"> <li>a) Check wiring, rectify fault and replace fuse</li> <li>b) Turn power switch ON</li> <li>c) Check connections</li> </ul>
Chart does not appear to move	<ul style="list-style-type: none"> <li>a) Very slow chart speed selected</li> <li>b) Chart stop function enabled</li> </ul>	<ul style="list-style-type: none"> <li>a) Select required chart speed in <b>Set Up Chart Page</b></li> <li>b) De-activate source being used to stop chart – see <b>Set Up Chart Page</b></li> </ul>
Pens in recording position but do not drop onto paper	Chart stop function enabled	De-activate source used to stop chart – see <b>Set Up Chart Page</b>
Red pen does not move beyond 94% position on chart	When real time event pen is fitted the red pen cannot go beyond 94% to prevent pens clashing	Use chart range which prevents the need to go beyond 94% of maximum on chart
Pen lift switch on front panel does not work	Pen lift switch is disabled	Enable pen-lift switch in <b>Set Up Chart Page</b>
Pens do not remain lifted when pen lift key is used	Auto pen drop feature is enabled	Disable auto pen drop in <b>Set Up Chart Page</b> if this is not required
Analog inputs are slow to respond	A large filter time has is set	Set digital filter value to give required response in <b>Set Up Inputs</b>
Time or date incorrect	Not set for correct local time	Set correct time and date in <b>Set Up Clock Page</b> – refer to <b>Advanced Software Manual</b>
Totalizers cannot be set to STOP or GO	Operator STOP/GO selection is not enabled in the <b>OPERATOR LEVEL</b>	Enable counter STOP/GO in the <b>Set Up Totals Page</b>
Totalizer cannot be set to STOP	Digital signal assigned to the total STOP/GO function is active	De-activate digital signal assigned to total STOP/GO function
External relays connected to relays in instrument fail to de-energize	Arc suppression capacitors are provided across the relay contacts and capacitor leakage current may be sufficient to prevent an external relay from de-energizing	Remove the arc suppression components – IC4 and IC5 on mainboard IC6 and IC7 on standard I/O and analog relay IC3 to IC10 on 4 relay module
Pens return to a different position after a pen-lift or power down	Pens are interfering with one another due to incorrect setting of pens	Each pen requires the force of 1 gram to lift it off the paper. Carefully bend arm (up or down) close to the plastic moulding to give correct setting

---

## 8 SPARES LIST

---

<b>Item</b>	<b>Part No.</b>
<b>Pen Capsules</b> (pack of 3)	
Black	C1900/0119
Blue	C1900/0120
Red	C1900/0121
Green	C1900/0122
Violet*	C1900/0123
<b>Pen Arm Assemblies</b>	
ER/C Type Chart (J or R in Code Number) – Standard Pen	C1900/0076
ER/C Type Chart (J or R in Code Number) – Event Pen	C1900/0078
PX105 and PXR105 Type Chart (K or S in Code Number) – Standard Pen	C1900/0075
PX105 and PXR105 Type Chart (K or S in Code Number) – Event Pen	C1900/0077
<b>Fuses</b>	
24V	B11071 (4A)
115V	B11070 (1A)
230V	B11069 (500mA)

\*True time line event option only.

---

## NOTES

---

# Products and customer support

## Automation Systems

For the following industries:

- Chemical & Pharmaceutical
- Food & Beverage
- Manufacturing
- Metals and Minerals
- Oil, Gas & Petrochemical
- Pulp and Paper

## Drives and Motors

- AC and DC Drives, AC and DC Machines, AC Motors to 1kV
- Drive Systems
- Force Measurement
- Servo Drives

## Controllers & Recorders

- Single and Multi-loop Controllers
- Circular Chart and Strip Chart Recorders
- Paperless Recorders
- Process Indicators

## Flexible Automation

- Industrial Robots and Robot Systems

## Flow Measurement

- Electromagnetic Flowmeters
- Mass Flowmeters
- Turbine Flowmeters
- Wedge Flow Elements

## Marine Systems & Turbochargers

- Electrical Systems
- Marine Equipment
- Offshore Retrofit and Refurbishment

## Process Analytics

- Process Gas Analysis
- Systems Integration

## Transmitters

- Pressure
- Temperature
- Level
- Interface Modules

## Valves, Actuators and Positioners

- Control Valves
- Actuators
- Positioners

## Water, Gas & Industrial Analytics Instrumentation

- pH, Conductivity and Dissolved Oxygen Transmitters and Sensors
- Ammonia, Nitrate, Phosphate, Silica, Sodium, Chloride, Fluoride, Dissolved Oxygen and Hydrazine Analyzers
- Zirconia Oxygen Analyzers, Katharometers, Hydrogen Purity and Purge-gas Monitors, Thermal Conductivity

## Customer support

We provide a comprehensive after sales service via a Worldwide Service Organization. Contact one of the following offices for details on your nearest Service and Repair Centre.

### UK

ABB Limited  
Tel: +44 (0)1453 826661  
Fax: +44 (0)1453 829671

### USA

ABB Inc.  
Tel: +1 215 674 6000  
Fax: +1 215 674 7183

### Client Warranty

Prior to installation, the equipment referred to in this manual must be stored in a clean, dry environment, in accordance with the Company's published specification. Periodic checks must be made on the equipment's condition. In the event of a failure under warranty, the following documentation must be provided as substantiation:

- A listing evidencing process operation and alarm logs at time of failure.
- Copies of all storage, installation, operating and maintenance records relating to the alleged faulty unit.

# Contact us

To find your local ABB contact visit:

[www.abb.com/contacts](http://www.abb.com/contacts)

For more product information visit:

[www.abb.com](http://www.abb.com)

## Note

We reserve the right to make technical changes or modify the contents of this document without prior notice. With regard to purchase orders, the agreed particulars shall prevail. ABB does not accept any responsibility whatsoever for potential errors or possible lack of information in this document.

We reserve all rights in this document and in the subject matter and illustrations contained therein. Any reproduction, disclosure to third parties or utilization of its contents in whole or in parts - is forbidden without prior written consent of ABB.

Copyright© 2010 ABB

All rights reserved

IM/C1900-OGC Rev. H 08.2010