

- **Wide measuring range**
 - covers all power plant applications
- **Automatic sample temperature compensation**
 - maximizes measurement accuracy
- **'Pumpless' liquid handling section**
 - ensures low maintenance
- **Comprehensive diagnostics facility with built-in software protection**
 - provides security and confidence in operation
- **Detachable cable electrode option**
 - simplifies maintenance
- **Reagent entrainment system**
 - sample flow controls addition of reagent;
no diffusion tubing required



A compact, competitively-priced
sodium monitor

Introduction

The prevention of damage to the boilers on modern power stations becomes more and more critical as the cost of repairs and out-of-service plant continues to rise. To reduce the effect of boiler tube corrosion and the formation of scale on the inside of the tubes, the levels of impurities in the various parts of the steam/water cycle must be monitored carefully.

Sodium ions are normally the most abundant element found in solution in boiler plant, therefore the measurement of sodium provides a valuable indication of the overall purity of the solution. While on-line conductivity can give useful information concerning the total concentration of the ionic element, it is far less sensitive than a specific measurement for sodium.

The points where on-line sampling for sodium would be required are:

- Water treatment plant
 - Sodium measurement, at the outlet of cation and mixed resin exchange beds, gives an early indication of resin exhaustion and treated water quality.
- Condensate monitoring at the extraction pump discharge
 - As condensers are operated under vacuum, leaks result in the ingress of cooling water into the process water. If the cooling water contains relatively high levels of sodium (as is usually the case), monitoring of sodium in the process water can provide an early indication of condenser leaks.
- Saturated steam in drum boilers
 - The monitoring of sodium in the saturated steam between the boiler drum and the superheater detects carryover and, in conjunction with sodium monitoring in the condensate (the sodium balance), can indicate problems caused by sodium deposits on superheated tubes and turbine blades.
- Once-through boilers
 - Since the purity of the boiler water is more stringent in these boilers, sodium monitoring, after the condensate polishing plant, boiler feed and superheated steam, can assist in maintaining water/steam purity within limits.

General Information

The ABB 8037 Sodium Monitor uses an ABB sodium ion-selective electrode and reference electrode to measure the sodium ion concentration in power station waters.

The model 8037 is an accurate, reliable instrument which requires very little maintenance and measures sodium ion concentrations within the ranges of 0.10 µg kg⁻¹ to 10mg.kg⁻¹.

The basic monitor is supplied with a panel- or wall-mount unit and cable-attached electrodes. Optional facilities are available as detailed below:

1. Detachable cable electrodes
2. Serial data interface
3. Second current output
4. Second current output
5. Reservoir-fed reference electrode
6. Environmental cover kit

Transmitter

The 8037 Series transmitter provides the operator interface and communications to other devices. The signal from the sensing system is converted by the transmitter and information is displayed as a $\mu\text{g/l}$, $\mu\text{g/kg}$, ppb, mg/l, mg/kg or ppm value.

A process retransmission signal and two alarm relay outputs are provided as standard. A second current output or RS485 serial interface, which allows the transmitter to be easily incorporated into an ABB PC30 or other Modbus-compatible supervisory systems, are available as options.

Available in wall-mount or $1/4$ DIN panel-mount versions, the transmitter is protected to IP66, ensuring reliable operation in the most demanding situations. The same level of protection is maintained during programming and calibration.

The large, easy-to-read, customized liquid crystal display (LCD) is used in conjunction with the four tactile membrane key pads to prompt the user through the programming procedures. Included, as standard, is a four-language software package, to display information in English, French, Spanish or German.

Sensing Panel

A flow schematic is shown opposite. The sample enters the monitor via the compression fitting on the 3-way changeover valve. It then passes through the changeover valve to the constant head unit which removes the effect of changes in sample pressure and flow-rate. A small tube, overflowing into the constant head on one side, ensures self-starting when the sample is lost and enables the monitor to function over a wide sample flow range.

The sample is then delivered to the entrainment 'T' piece and stainless steel entrainment tube, where an alkaline vapor reagent is added to raise the pH value, before flowing past the sodium and reference electrodes mounted in the flowcell. Finally, the sample leaves the flowcell and exits to drain.

The potential developed between the sodium ion-responsive electrode and silver/silver chloride reference electrode is logarithmic with respect to changes in sodium ion concentration. The signal from the electrode pair is connected to the 8037 Transmitter.

A temperature sensor, fitted into the flowcell, detects the temperature of the sample. The sensor is connected to the transmitter unit which compensates for changes in output from the electrode pair over a range of 5 to 55 °C (41 to 131 °F).

Calibration is carried out manually after connection of the calibration tube to the standard solution container. The 3-way changeover valve on the liquid handling panel is changed-over manually from sample to standard solution. The calibration is initiated from the transmitter unit, where it is controlled by the microprocessor. The standard solution takes the same path as the sample through the liquid handling panel.

Schematic Flow Diagram

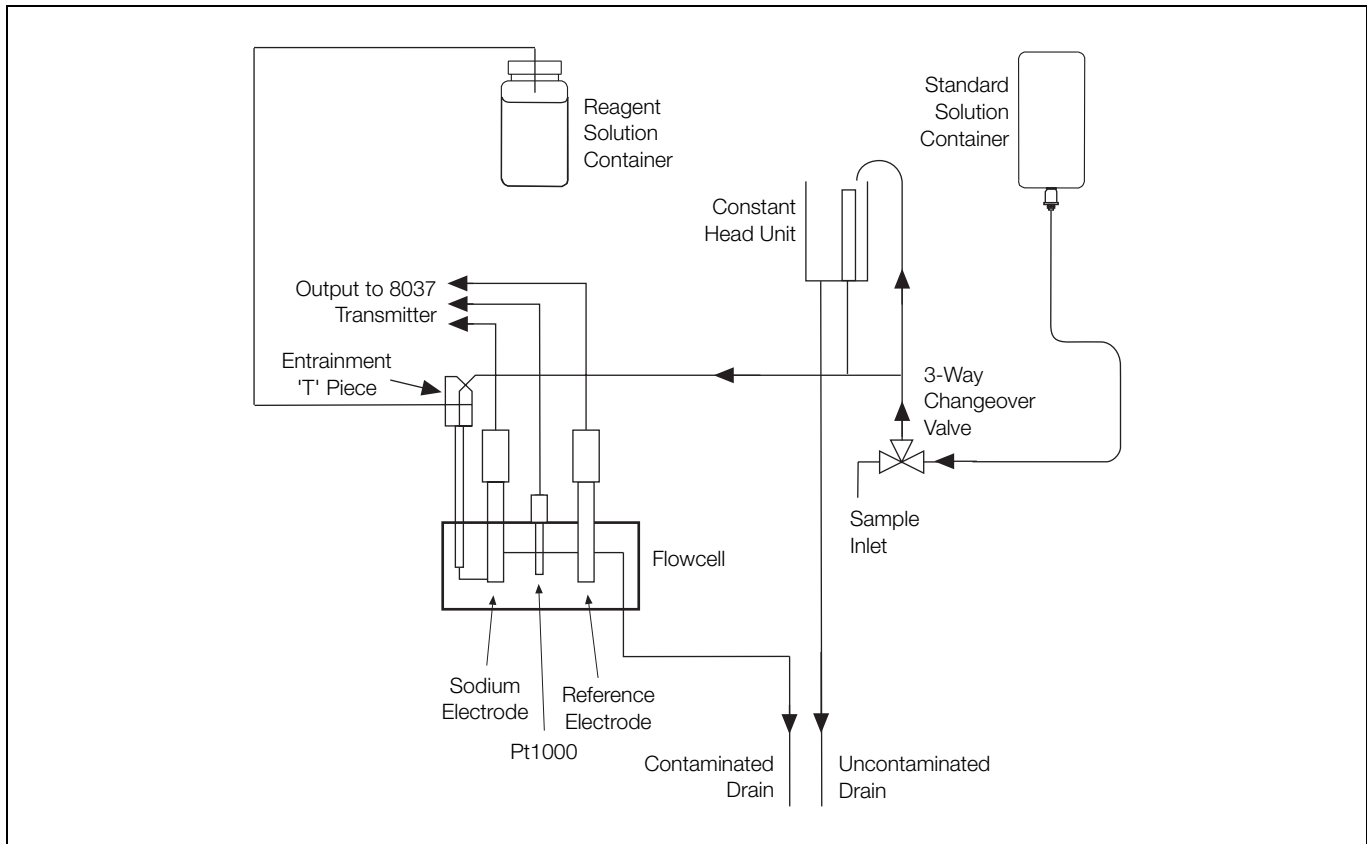

Schematic Flow Diagram

Components of 8037 Sodium Monitor

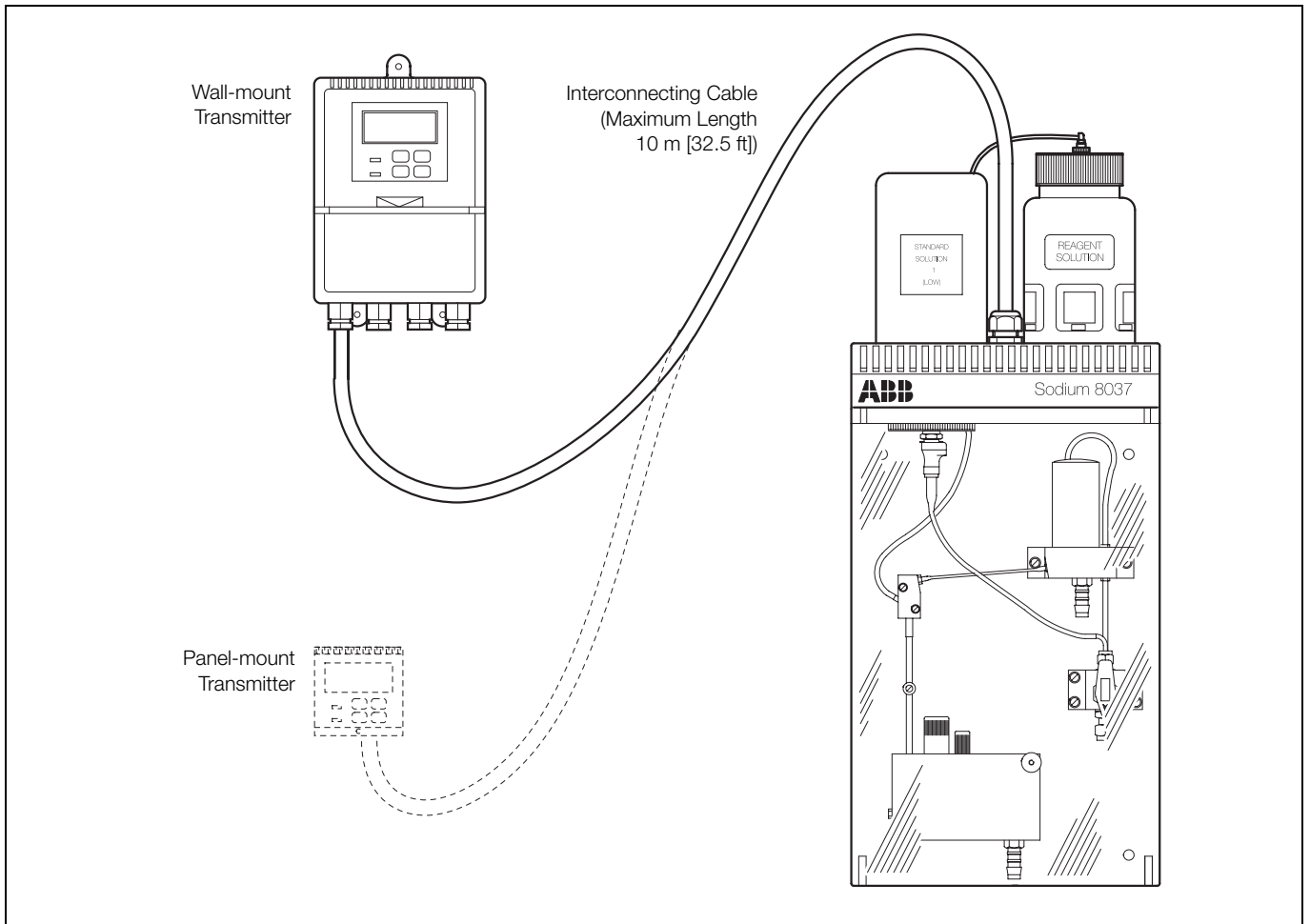

Components of 8037 Sodium Monitor

Specification

General

Display

Measured value	5-digit, 7-segment back-lit LCD
Information	16-character, single-line, dot matrix back-lit LCD

Display range

0.01 $\mu\text{g kg}^{-1}$ to 10 mg.kg^{-1}

Units of measure

ppb / ppm
 $\mu\text{g/l}$ / mg/l
 $\mu\text{g kg}^{-1}$ / mg.kg^{-1}

Current output expansion

Scale expansion between 2 and 4 decades logarithmic or the equivalent linearized

Programmable in the range 0.10 $\mu\text{g kg}^{-1}$ to 10 mg kg^{-1}

Maximum load resistance 500 Ω (20 mA)

Display resolution

0.01 $\mu\text{g kg}^{-1}$ in range 0.01 $\mu\text{g kg}^{-1}$ to 9.99 $\mu\text{g kg}^{-1}$

0.1 $\mu\text{g kg}^{-1}$ in range 10.0 $\mu\text{g kg}^{-1}$ to 99.9 $\mu\text{g kg}^{-1}$

1 $\mu\text{g kg}^{-1}$ in range 100 $\mu\text{g kg}^{-1}$ to 999 $\mu\text{g kg}^{-1}$

0.01 mg kg^{-1} in range 1.00 mg kg^{-1} to 9.99 mg kg^{-1}

Accuracy

$\pm 10\%$ of concentration or $\pm 0.1 \mu\text{g kg}^{-1}$ whichever is the greater (when sample temperature is within $\pm 5\text{ }^\circ\text{C}$ ($\pm 9\text{ }^\circ\text{F}$) of calibration temperature)

Reproducibility

$\pm 5\%$ of concentration or 0.1 $\mu\text{g kg}^{-1}$

(whichever is the greater) at constant temperature

Response time

1 to 100 $\mu\text{g kg}^{-1}$ less than 4 minutes for 90 % step change

100 to 1 $\mu\text{g kg}^{-1}$ less than 6 minutes for 90 % step change

Temperature compensation

Automatic within $\pm 5\text{ }^\circ\text{C}$ ($\pm 9\text{ }^\circ\text{F}$) of calibration temperature

Current outputs

One, fully isolated

Two, fully isolated (optional)

0 to 10, 0 to 20 or 4 to 20 mA, programmable

Serial communication

RS422/RS485 (optional)

Modbus compatible

Alarms

Two fail-safe, high and low concentration alarms

Hysteresis $\pm 1\%$ of FSD (fixed)

Relay contacts (single pole changeover)

Rating	250 V AC	250 V DC max.
--------	----------	---------------

	3 A AC	3 A DC max.
--	--------	-------------

Loading	(non-inductive)	750 VA 30 W max.
---------	-----------------	------------------

	(inductive)	75 VA 3 W max.
--	-------------	----------------

Insulation, contacts to earth: 2 kV RMS

Calibration

Manual initiation of calibration sequence

Calibration frequency (typically) weekly for 1-point, and 4-weekly for 2-point calibration

Installation Information

Sample temperature

5 to 55 °C (41 to 131 °F)

Sample flow

50 ml/min-1 to 500 ml/min-1

Sample pressure (gauge)

Maximum 0.14 bar (2 psi)

Outlet from sensing panel must go to atmospheric drain

Ambient temperature

0 to 55 °C (32 to 131 °F)

Dimensions of sensing panel

250 mm (9.84 in) wide x 440 mm (17.32 in) high

(690 mm [27.16 in] high to clear bottle assemblies) x

160 mm (6.29 in) deep

Mounting for sensing panel

Four holes – 8.5 mm (0.33 in) diameter

200 mm (7.87 in) horizontal

325 mm (12.79 in) vertical

Weight of sensing panel

11 kg (24.3 lb) (including optional environmental cover)

Connections to sensing panel

Sample inlet 1/4 in OD compression fitting (6.3 mm)

Sample drains 10 mm (0.39 in) ID flexible, atmospheric drain

Dimensions of transmitter unit

Wall-mount unit

160 mm (6.29 in) x 214 mm (8.42 in) x 68 mm (2.67 in)

Panel-mount unit

96 mm (3.78 in) x 96 mm (3.78 in) x 191 mm (7.52 in)

(cut-out 92 mm [3.62 in] x 92 mm [3.62 in])

Weight of transmitter unit

Wall-mount: 2 kg (4.41 lb)

Panel-mount: 1.5 kg (3.31 lb)

Power supply requirements

115 V nom. ±15 V, 50/60 Hz or

230 V nom. ±30 V, 50/60 Hz

Power consumption

<10 VA

Insulation, mains to earth

2 kV RMS

Max. cable core sizes

Mains supply 32/0.2 mm

Signal 24/0.2 mm

Maximum distance between sensor & transmitter unit

10 m (32.8 ft)

Environmental Data

Storage temperature limits

0 °C to 55 °C (32 to 131 °F)

Operating humidity limits

Up to 95 % RH non-condensing

Environmental protection

Wall-mount transmitter IP66/NEMA4X

Panel-mount transmitter IP66/NEMA4X (front)

Installation

It is recommended that the sample supply line is fitted with a needle valve and flow indicator (not supplied) and the sample is discharged from the monitor to an atmospheric drain.

Maximum distance between sensing panel and transmitter 10m (32.8 ft) (with detachable-cable electrode option)

Sensing Panel Installation Details

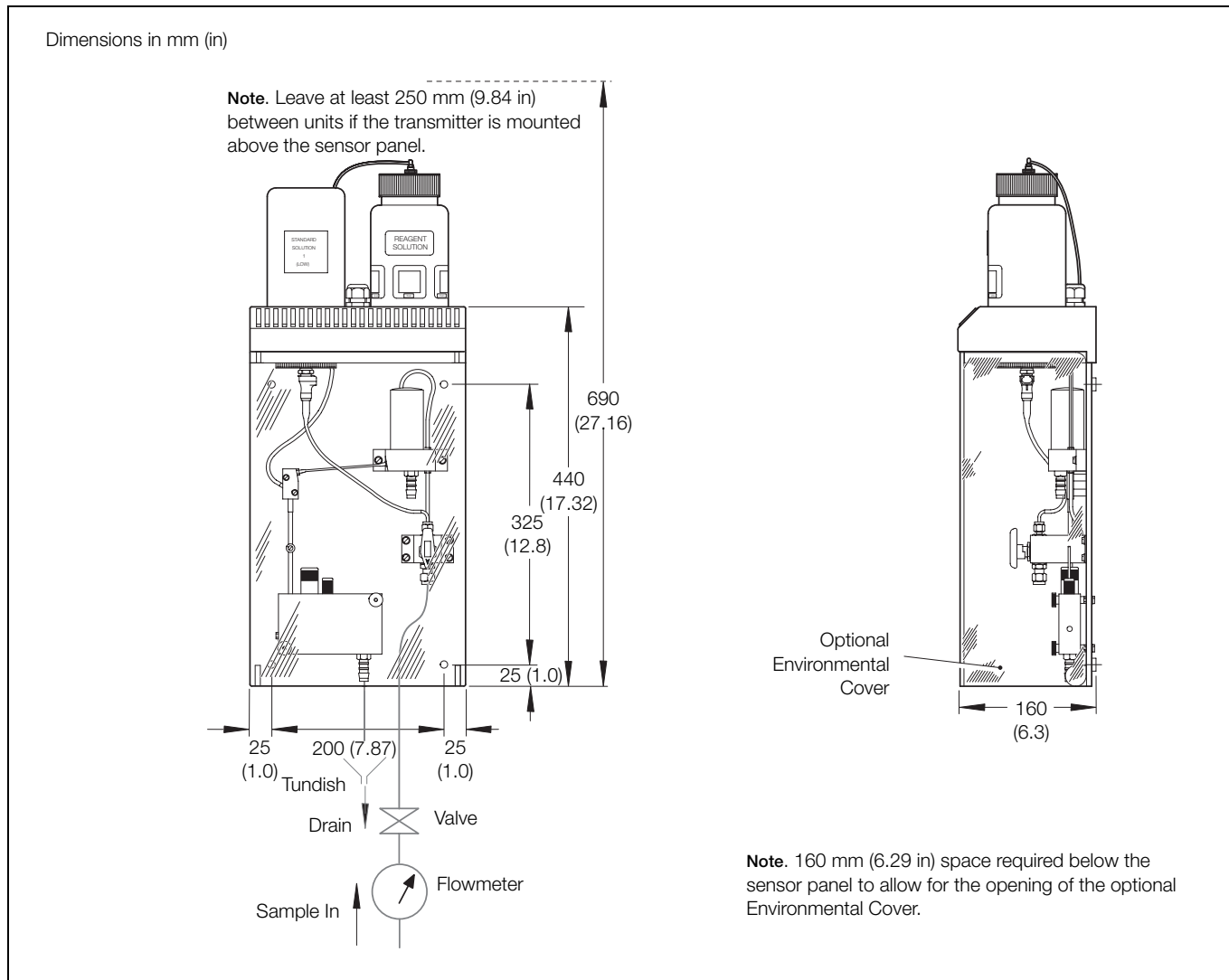

Sensing Panel Installation Details

Overall Dimensions

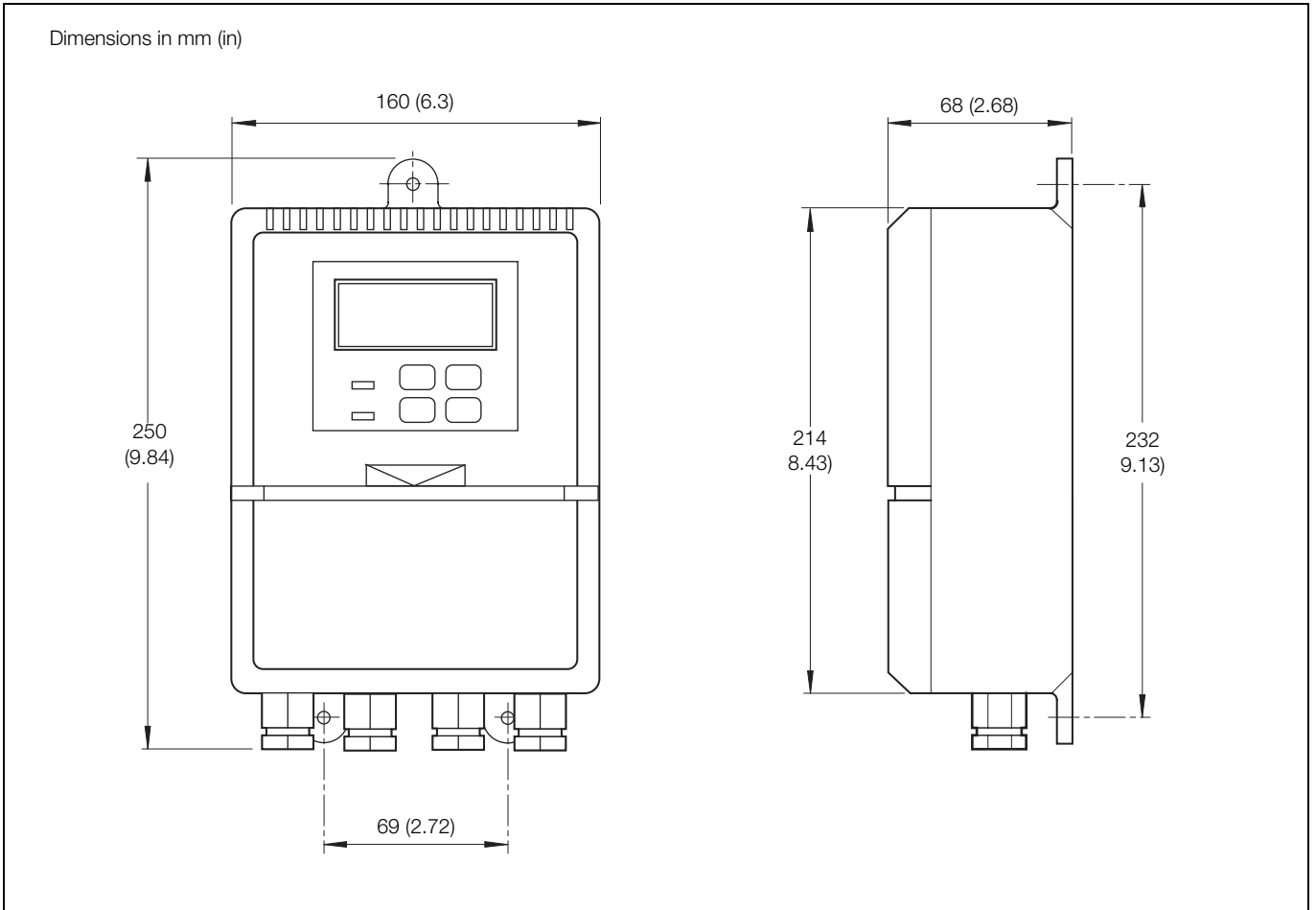

8037 Model Wall-mount Version

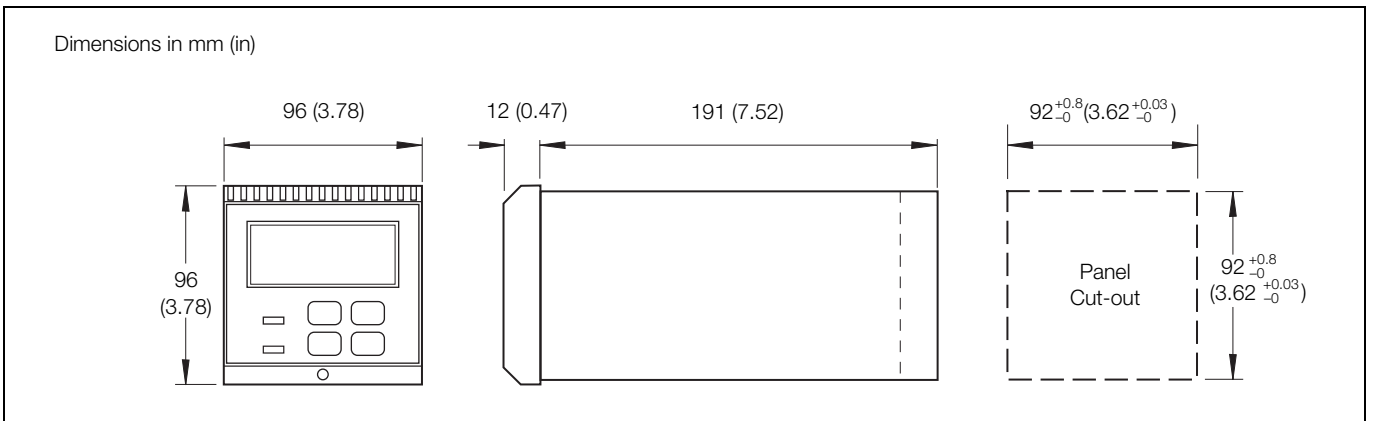

8037 Model Panel-mount Version

Electrical Connections

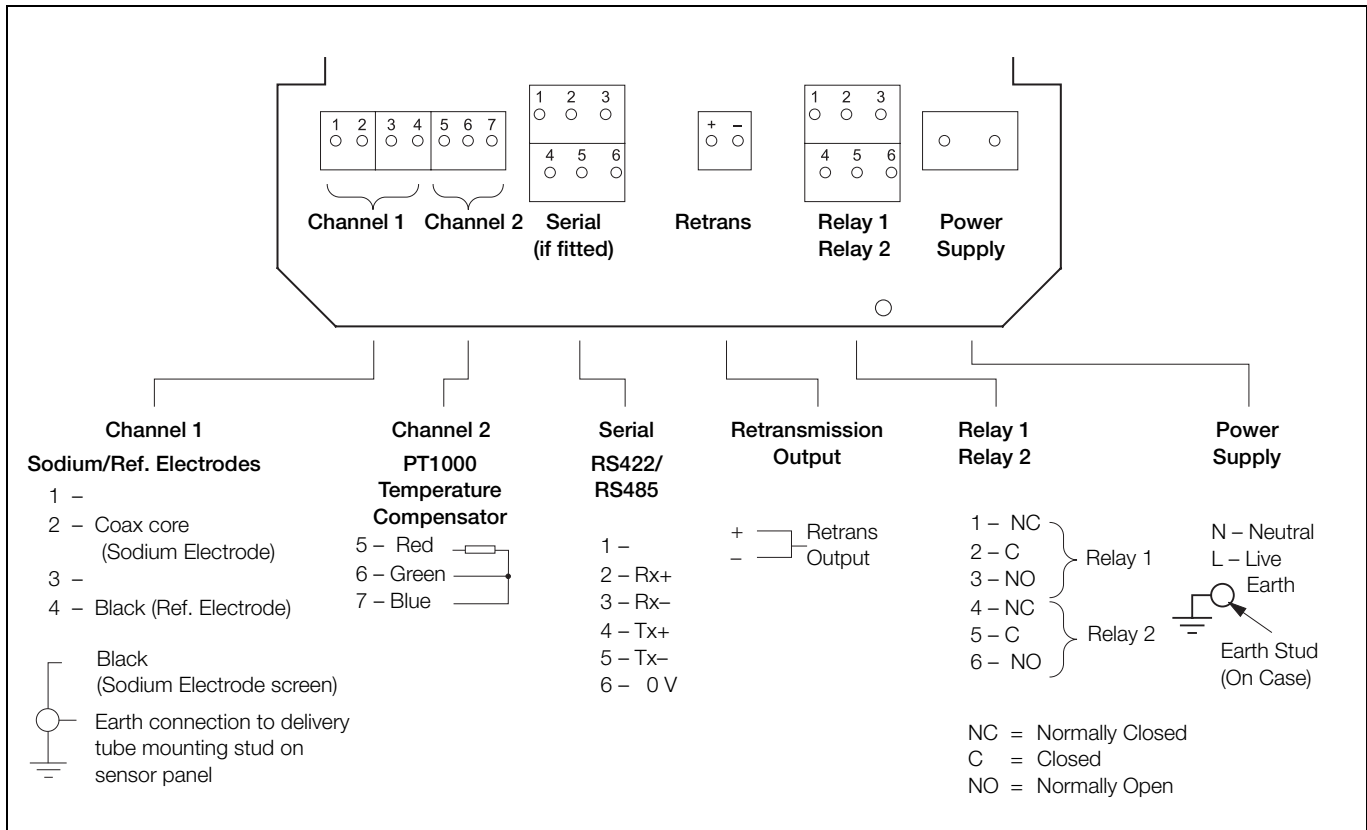

8037 Model Wall-mount Version

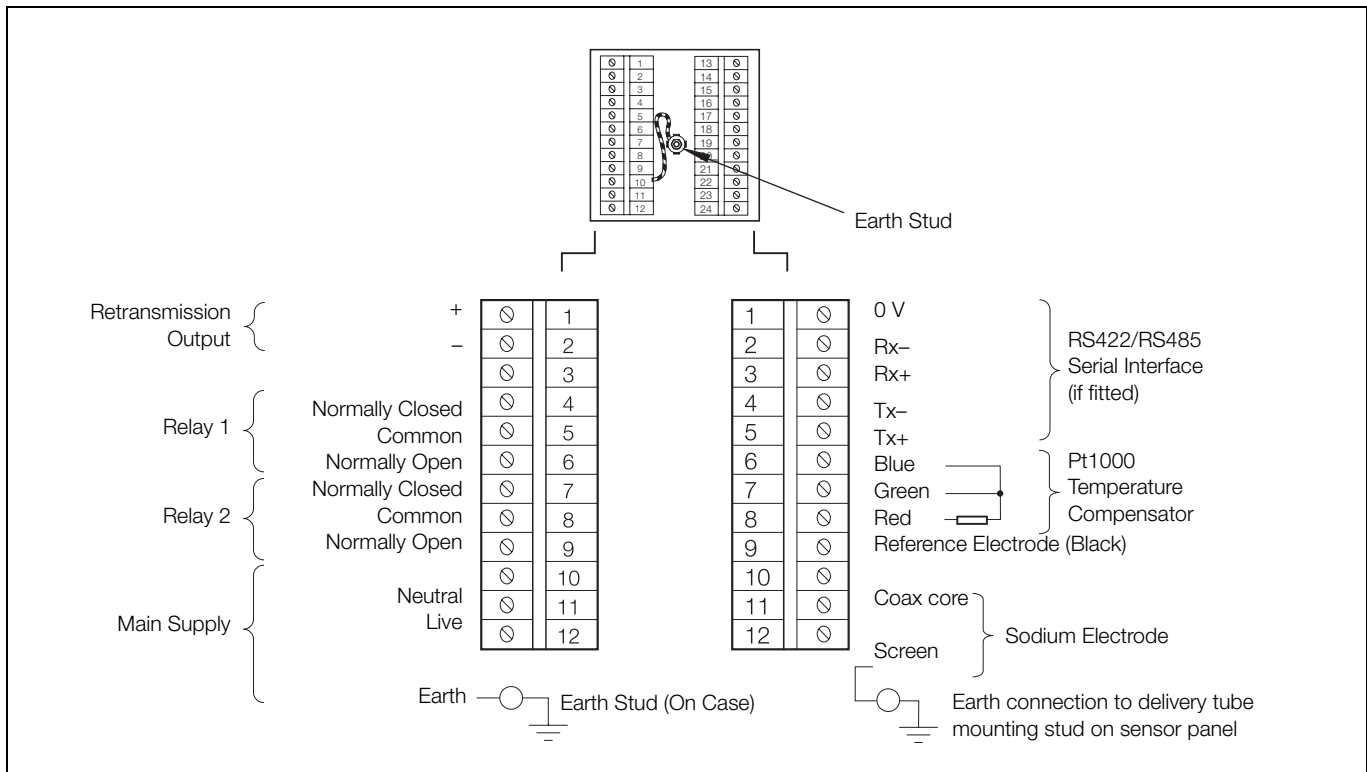

8037 Model Panel-mount Version

Ordering Information

Model 8037 Sodium Monitor	8037/00	X	X	X	X	X	X	X
Standard								
Standard		0						
Special		9						
Enclosure								
Wall-mount transmitter			0					
Panel-mount transmitter			1					
Output								
Current output only				0				
Current output and serial data interface (Modbus optional)				1				
2 current outputs				2				
Electrode Type								
Cable attached electrodes (1 m [39 in] only)					0			
Cable detached electrodes					1			
Cable detached electrodes (reservoir-fed reference)					2			
Cable Assemblies								
Cable attached electrodes						0		
1 m (39 in) cable assemblies						1		
3 m (9.75 ft) cable assemblies						2		
5 m (16.25 ft) cable assemblies						3		
10 m (32.5 ft) cable assemblies						4		
Optional Items								
Without environmental cover kit							0	
With environmental cover kit							1	
Language								
English								0
German								1
French								2
Spanish								3

Reservoir-fed Reference Electrode Kit

A kit to upgrade Model 8037 from using a refillable reference electrode to one using a reservoir-fed reference electrode is available - part no. 8037-150.

Modbus is a trademark of Modicon Inc.

ABB has Sales & Customer Support expertise
in over 100 countries worldwide

www.abb.com

The Company's policy is one of continuous product
improvement and the right is reserved to modify the
information contained herein without notice.

Printed in UK (12.07)

© ABB 2007



ABB Limited
Oldends Lane, Stonehouse
Gloucestershire
GL10 3TA
UK
Tel: +44 (0)1453 826661
Fax: +44 (0)1453 829671

ABB Inc.
125 E. County Line Road
Warminster
PA 18974
USA
Tel: +1 215 674 6000
Fax: +1 215 674 7183