

WaterMaster Electromagnetic flowmeter



The Company

We are an established world force in the design and manufacture of instrumentation for industrial process control, flow measurement, gas and liquid analysis and environmental applications.

As a part of ABB, a world leader in process automation technology, we offer customers application expertise, service and support worldwide.

We are committed to teamwork, high quality manufacturing, advanced technology and unrivalled service and support.

The quality, accuracy and performance of the Company's products result from over 100 years experience, combined with a continuous program of innovative design and development to incorporate the latest technology.

Contents

1	Introduction	3
1.1	PROFIBUS	3
1.1.1	PROFIBUS DP	3
1.1.2	PROFIBUS PA	3
1.2	PROFIBUS and ABB Products	4
1.3	PROFIBUS DP Transmission Technology	4
1.4	Acronyms and Abbreviations	5
1.5	PROFIBUS Interface	5
2	Installation	6
2.1	Installation Overview	6
2.2	Cable Length	7
2.3	Cable Specification	7
3	Network Connection	8
3.1	Network Connections	8
4	Configuration	9
4.1	Setting the PROFIBUS Station Address	9
4.2	Integration using GSD	11
4.2.1	Condensed Diagnostic Status	12
4.2.2	Cyclic Data Exchange Modules	12
4.3	Configuration from the WaterMaster Display	14
4.4	Configuration using Device Type Manager (DTM) Software	15
4.5	Configuration using an EDD	15
5	PROFIBUS Block Parameters	16
6	Error and Warning Handling	20
6.1	Device Alarms	20
6.2	Diagnostic Message Formats	21
6.3	Extended Diagnostics	21
6.3.1	DIAGNOSIS Parameter	22
6.3.2	DIAGNOSIS_EXTENSION Parameter	24
6.4	Mapping Alarms to Transducer Block Status	26
6.4.1	Extended Status Tables	26
6.4.2	Condensed Status Tables	32
7	Identification and Maintenance	38
Appendix A	– PROFIBUS-PA Block Structure Diagrams	41
A.1	Analog Input Function Block	41
A.2	Totalizer Function Block	43
A.3	Analog Output Function Block	45
A.4	Flow Transducer Block	48

Appendix B – PROFIBUS Data Structures	49
Appendix C – FEX100-DP PROFIBUS Datasheet	51
Appendix D – Declaration of PROFIBUS Conformance	52

1 Introduction

This publication contains information specific to the PROFIBUS®-enabled WaterMaster with RS485 physical layer (PNO registered model FEX100-DP). It must be read in conjunction with IM/WMP and IM/WMPST-EN. The PROFIBUS model name FEX100-DP is applicable to several variants of the WaterMaster flowmeter system (for example, FEV1xx, FEF1xx, FET1xx). Refer to data sheet DS/WM-EN for details of specific order codes.

1.1 PROFIBUS

PROFIBUS is a manufacturer-independent, open Fieldbus standard for a wide range of applications in manufacturing, process and building automation. Manufacturer independence and openness are ensured by the international standard EN 50170.

Using the PROFIBUS protocol, devices from different manufacturers exchange information on the same communications bus without the need for special interface equipment.

Further information on PROFIBUS can be found at www.profibus.com.

1.1.1 PROFIBUS DP

PROFIBUS DP is designed for high-speed data exchange and is commonly used by complex or externally-powered devices. The central controller or 'master' device (for example, PLC or PC) utilizes PROFIBUS DP as a fast serial connection with distributed (slave) field devices such as PROFIBUS-enabled WaterMasters.

The master device reads the input information cyclically in a defined, recurring order from the slave(s). When configuring the bus system, the user assigns an address in the range 0 to 125 to each slave device and also defines which of the slaves are to be included in, or excluded from, the data acquisition cycle.

1.1.2 PROFIBUS PA

PROFIBUS-PA is designed to accommodate process automation field devices and specifies an application profile that characterizes device behavior and parameters in a standard way making integration with a controller easier.

PROFIBUS-PA supports several physical layer options including RS485 and the IEC61168-2 current-loop based bus that can power low-power devices from the bus and is ideal for intrinsic safety in hazardous areas.

1.2 PROFIBUS and ABB Products

WaterMaster utilizes PROFIBUS DP as this protocol is optimized for high speed and low connection costs (see www.abb.com/fieldbus and follow the PROFIBUS link).

The WaterMaster FEX100-DP variant has an RS485 physical layer so, while it benefits from the well-defined PROFIBUS PA application profile (version 3.01), it can also be connected directly to a traditional PROFIBUS-DP RS485 network.

1.3 PROFIBUS DP Transmission Technology

The most common transfer method of PROFIBUS-DP is RS485 – a proven technology. A twisted, shielded, 2-wire copper cable is used as the transfer medium.

The bus structure enables addition and removal of stations or step-by-step commissioning of the system without affecting other stations. Later expansion has no influence on stations already in operation.

Transmission speeds from 9.6 kbps up to 1.5 Mbps are supported. One uniform transmission speed is selected for all devices on the bus when the system is commissioned.

1.4 Acronyms and Abbreviations

AI	Analog Output Function Block
AO	Analog Output Function Block
FB	PROFIBUS-PA Function Block
Input	Data passed into a Master device (for example, from a Slave device)
I&M	PROFIBUS Identification and Maintenance function
MS1	Class 1 Master-Slave acyclic transaction
MS2	Class 2 Master-Slave acyclic transaction
Output	Data passed out of a Master device (for example, to a Slave device)
PA	PROFIBUS-PA application profile
PB	PROFIBUS-PA Physical Block
PCS/DCS	Process control system / distributed control system
PI/PNO	PROFIBUS International / PROFIBUS User Organization (www.profibus.com)
TB	PROFIBUS-PA Transducer Block
TOT	Totalizer Function Block

Table 1.1 Acronyms and Abbreviations

1.5 PROFIBUS Interface

Physical layer	RS485
Supported baud rates	9.6 kbps to 1.5 Mbps
Supported DP Protocol services	DPV0, DPV1
Concurrent MS2 connections	3
Device stub length	250 mm (9.8 in.)
Application profile	PA version 3.01
Master components available	GSD, DTM, EDD

Table 1.2 PROFIBUS Interface

2 Installation

2.1 Installation Overview

All devices are connected in a bus structure ('line') as shown in Fig 2.1. Up to 32 stations (master or slaves) can be linked to create one 'segment', although it is recommended not to install more than 16 devices on a single segment.

Each end of a segment must be terminated by an active bus terminating resistor. Both bus terminators must always be powered to ensure fault-free operation, therefore it is strongly recommended that they are connected to a back-up power supply. The use of bus amplifiers (repeaters) and segment couplers can be used to extend the network.

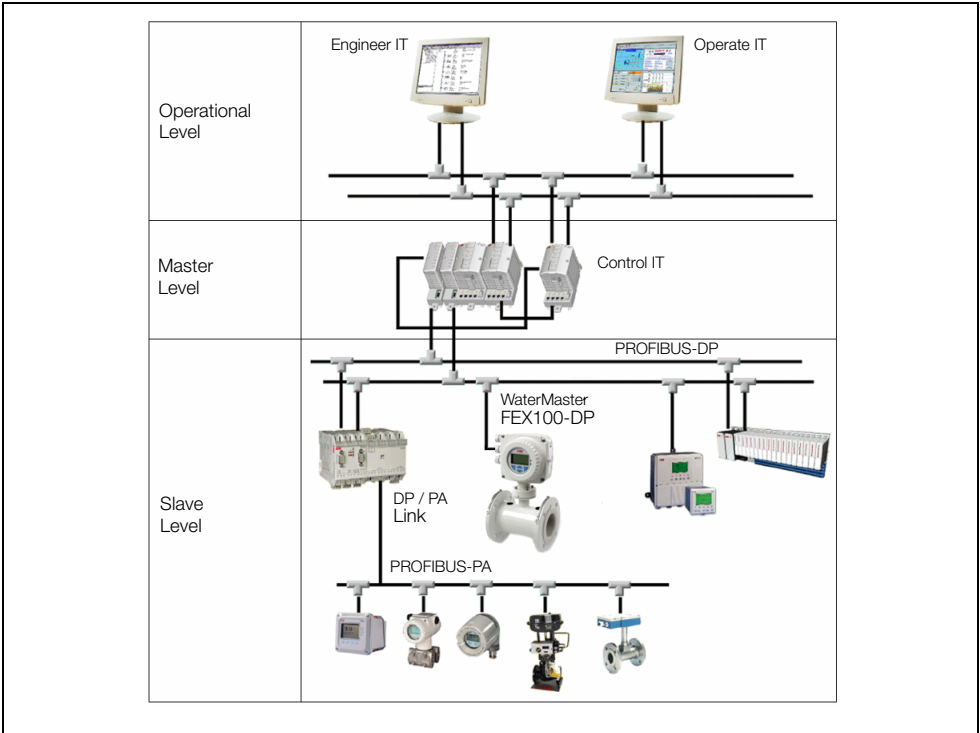

Fig. 2.1 Typical PROFIBUS Network

2.2 Cable Length

The maximum cable length of a segment is determined by the transmission speed (see Table 2.1). The cable length specified can be extended using repeaters, but it is recommended that no more than 3 repeaters are connected in series.

Transmission Rate (bits / second)	Maximum Segment Length (m [ft.])	Maximum Total Network Length (m [ft.])
9.6 to 93.75 kbps	1200 (3937)	4800 (15748)
187.5 kbps	1000 (3280)	4000 (13123)
500 kbps	400 (1312)	1600 (5249)
1.5 Mbps	200 (656)	800 (2624)
3 to 12 Mbps	100 (328)	400 (1312)

Table 2.1 Cable Length

2.3 Cable Specification

The cable lengths in Table 2.1 refer to the following cable type:

Characteristic impedance	135 to 165 Ω
Capacitance per unit length	<30 pf/m
Loop resistance	110 Ω /km
Core diameter	0.64 mm
Core cross section	>0.34 mm ²

Table 2.2 Cable Specification

Suitable PROFIBUS cable (part numbers PCA010, PCA011 and PCA012) can be obtained from ABB. Refer to Data Sheet 10/63-6.46 EN.

3 Network Connection

Caution.

When connecting a WaterMaster to a PROFIBUS-DP RS485 network:

- Refer to the WaterMaster User Guide (IM/WM) before making electrical connections.
- Refer to IM/WM for all other installation and connection details.
- Use cable that meets PROFIBUS specifications for reliable RS485 communications.
- Ensure RS485 signals are not reversed.
- Ensure a PROFIBUS active terminator is fitted each end of the RS485 bus segment.
- Route data lines clear of the source of any strong electrical and magnetic fields.

3.1 Network Connections

PROFIBUS network connections are made to the terminal blocks on the WaterMaster backplane PCB located below the cartridge assembly (refer to Fig 3.1). Refer to IM/WM to remove the cartridge assembly and access these terminals and to replace the cartridge before powering up the transmitter.

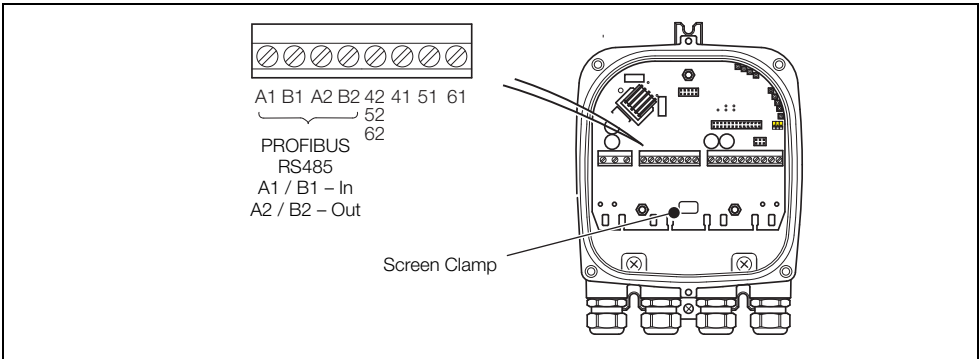

Fig. 3.1 WaterMaster RS485 Backplane Connections to PROFIBUS Network

Data Signal	Cable Color	Description
A	Green	Negative (-) data line: connect to pin 8 on PROFIBUS DP equipment with 9-way D-type connectors.
B	Red	Positive (+) data line: connect to pin 3 on PROFIBUS DP equipment with 9-way D-type connectors.
Braided screen	N / A	Cable screen – usually connected to the D-type shell or pin 1 on PROFIBUS DP equipment with 9-way D-type connectors.

Table 3.1 PROFIBUS DP Data Cable Signals

4 Configuration



4.1 Setting the PROFIBUS Station Address

The PROFIBUS Station Address for a WaterMaster can be set set locally via the keypad and menus or remotely by a master using the SET_SLAVE_ADDRESS service.

When the PROFIBUS Master sets the transmitter's Station Address, the address is stored and overwrites the address value previously held in the the instrument.

Warning. The WaterMaster reboots after its PROFIBUS Station Address parameter is changed. During this period it is not visible to any PROFIBUS masters.



To change the Station Address:

- 1 From the *Operator* page, press  (the key beneath the  icon).

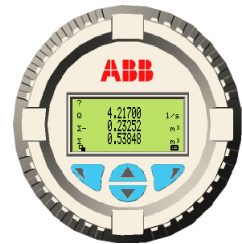

The *Access Level* is displayed.

Note. Values displayed on the *Operator* page are determined by the transmitter's configuration – refer to IM/WMP for configuration details.

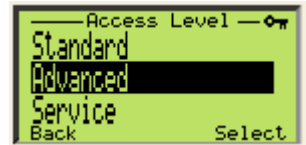

- 2 Use the  and  keys to scroll to the *Advanced* menu and press  to display the *Enter Password* page.



- 3 Use the  and  keys to move to and highlight the first password character.

Press  to select the character.

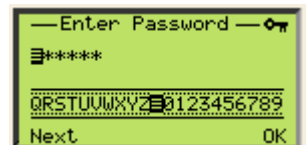

Navigate to and select any additional password characters.

Press  to accept the password and log in to the *Operator* level menu.





Note. The factory default password for *Advanced* level access is null or no password (this can be changed in the *Device Setup* pages).

If an invalid password is entered, the *Advanced* level menus cannot be accessed and the *Operator* page is displayed.

- 4 Use the  and  keys to move to the *Communication* page.



Press  to enter the *Communication* level.



- 5 Use the  and  keys to move to and highlight the *PROFIBUS* menu.

Press  to enter the *PROFIBUS* level.





- 6 If the *Station Address* menu is not already highlighted, use the  and  keys to move to and highlight the *Station Address* menu.

Press  to enter the PROFIBUS / *Station Address* page.





- 7 The current *Station Address* setting (for example 70) is displayed.

To edit this value, press  to enter the *Station Address* edit page.

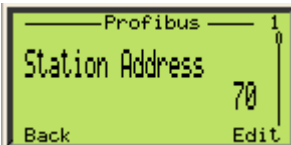
Note. To exit the page without changing the setting and return to the *Operator* page, press  4 times.



- 8 Use the  key to move between editable numbers and use the  and  keys to increment / decrement each number.

Press  to accept the new value and exit the *Station Address* edit page.

Note. Press  4 times to return to the *Operator* page.

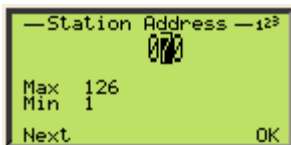

4.2 Integration using GSD

PROFIBUS devices differ with respect to available functionality and parameters for each device type and manufacturer. In order to obtain 'Plug-and-Play' configuration for PROFIBUS, characteristic device communication features such as manufacturer name, device name, hardware / software versions, baud rate and the number and nature of inputs / outputs are defined in an electronic device data sheet known as a GSD (Generic Station Description) file.

A GSD file is readable ASCII text file that contains both general and device-specific specifications for communication. Each of the entries describes a feature supported by a device. By using keywords, a configuration tool reads the device identification, the adjustable parameters, the corresponding data type and the permitted limit values for the configuration of the device from the GSD. Some keywords are mandatory, for example, `Vendor_Name`; others are optional, for example, `Sync_Mode_supported`.

The GSD file for WaterMasters specifies the device-specific Ident No. 3431. It conforms to the PROFIBUS standard, providing a clear and comprehensive description of each instrument in a precisely defined format. This enables the system configuration tool to use the information automatically when configuring a PROFIBUS bus system.

The ABB GSD file (Ident No. 3431) is divided into 2 sections:

- **General Specifications**

Identification of the device, together with hardware and software versions, baud rates supported and the possible time intervals for monitoring times.

- **DP Slave-Related Specifications**

Information about the user parameter block for device-specific configuration and modules containing details of the input and output data that can be exchanged cyclically with a PROFIBUS master.

The WaterMaster GSD file (`ABB_3431.gsd`) is available for download from the ABB website at: www.abb.com/fieldbus (follow the link for PROFIBUS DP field devices).

4.2.1 Condensed Diagnostic Status

WaterMaster supports enabling / disabling of condensed diagnostic status (as the PROFIBUS PA version 3.01 profile specification) via the PRM_COND bit of the profile-specific Prm_Structure that can be included by the SET_PRM service, depending on the settings in the GSD file.

Values for the Prm_Structure octets sent in the SET_PRM service are defined in the WaterMaster-specific GSD file.

Condensed status / diagnostics are disabled by default, if the Prm_Structure is not sent in the SET_PRM service.

Octet	Description
0	Structure length – fixed to 5
1	Structure type – fixed to 65 (profile-specific)
2	Slot number – fixed to 0 (settings in Prm_Structure apply to whole device)
3	Reserved – fixed to 0
4	Options: Bit0 PRM_COND: 1 = condensed status enabled 0 = condensed status disabled Bit1 to Bit7 Reserved – fixed to 0

Table 4.1 Profile-specific Prm_Structure

4.2.2 Cyclic Data Exchange Modules

Modules are defined for the following functions (see Table 4.2). Their formats are in accordance with PROFIBUS PA version 3.01 Function Block specifications – see Appendix A for details of the structure of these blocks.

Module	Data Type
1	Empty Module (for slot not used)
2	Analog Input OUT (input) value
3	Totalizer TOTAL (input) value
4	Totalizer SET_TOT (output) and TOTAL (input) values
5	Totalizer SET_TOT (output), MODE_TOT (output) and TOTAL (input) values
6	Analog Output SP (output) value

Table 4.2 GSD File Module Definitions (Ident No. 3431)

Selection of modules operates for the following slots:

Slot	Slot Name (see Table for Slot Descriptions)	Module Options	
		Default	Option(s)
1	AI1 Volume Flowrate (Q)	2	1,2
2	TOT1 Totalizer 1	3	1, 3, 4, 5
3	TOT2 Totalizer 2	3	1, 3, 4, 5
4	AI2 Internal Volume (FWD)	2	1, 2
5	AI3 Internal Volume (REV)	2	1, 2
6	AI4 Diagnostics	2	1, 2
7	AO1 Display Value	6	1, 6

Table 4.3 GSD file slot definitions

Slot Name	Description
AI1 Volume Flowrate (Q)	The meter's primary process measurement value.
TOT1 Totalizer 1	PROFIBUS PA totalizer for volumetric flow. Operation is determined by the MODE setting. Factory set to forward flow totalization.
TOT2 Totalizer 2	PROFIBUS PA totalizer for volumetric flow. Operation is determined by the MODE setting. Factory set to reverse flow totalization.
AI2 Internal Volume (FWD)	The meter's internal forward volumetric flow totalizer (as shown on the local display).
AI3 Internal Volume (REV)	The meter's internal reverse volumetric flow totalizer (as shown on the local display).
AI4 Diagnostics	To read system diagnostic measurements such as coil current etc. The AI CHANNEL number determines the source.
AO1 Display Value	A process value from another instrument to be shown on the WaterMaster's local display in addition to its own process values.

Table 4.4 GSD File Slot Name Descriptions

4.3 Configuration from the WaterMaster Display

PROFIBUS-related parameters are configured from the WaterMaster's *Communication / PROFIBUS* page.

PROFIBUS parameters are readable at all access levels. Write access to secure (writable) parameters is possible only at 'Advanced' access level. Refer to Section 4.1, page 9 and the WaterMaster User Guide (IM/WMP) for details of *Access Level* page parameters.

PROFIBUS parameters options are described in Table 4.5.



Parameter	Description
<i>Station Address</i>	Sets the PROFIBUS <i>Station Address</i> value – see page 10.
<i>Ident Select</i>	Selected profile ident number. Options are the specific WaterMaster ident number (3431) and supported profile specific ident numbers.
<i>Data Exchange State</i>	Indicates if the transmitter is in cyclic data exchange with a PROFIBUS master (read only parameter). <i>Active</i> <i>Inactive</i>
<i>Baud Rate</i>	Indicates the baud rate (in kbps) the transmitter has locked on to (read only parameter).

Table 4.5 PROFIBUS Parameter Descriptions

4.4 Configuration using Device Type Manager (DTM) Software

The WaterMaster DTM can be used for acyclic parameter configuration and monitoring of measurement values using a suitable PC-based FDT 1.2/1.2.1 frame application tool (such as ABB AssetVision Basic) and a Class 2 PROFIBUS master (with its corresponding Communication DTM).

Downloads and Bundles:

- AssetVision Basic – available as a download from the ABB website at www.abb.com/fieldbus (follow the link for Scalable Device Management Tools).
- WaterMaster DTM – available as a download from the ABB website at www.abb.com/fieldbus (follow the link for DTM Bundle) or supplied in the ABB DTM500 Bundle – contact ABB sales for details.

An example dialog from the WaterMaster PROFIBUS FEX100-DP DTM is shown in Fig. 4.1.

Block Parameters	
Static Revision Counter	0
TAG	<input type="text"/>
Strategy	0

Operating Mode	
Meter Mode	Forward And Reverse

Units	
Volume & Pulse Unit	m ³
Q (Flowrate) Unit	m ³ /h

Probe	
Probe Pipe Bore	250 mm
Profile Factor	1.0000

Qmax	
Qmax DN(Special)	2.50000 m ³ /h
Qmax DN	0.00000 m ³ /h

Fig. 4.1 Example Dialog – Extract from WaterMaster FEX100-DP DTM

4.5 Configuration using an EDD

Similar to the use of a DTM, configuration of WaterMaster parameters and monitoring of measurement values is possible using an EDD interpreter application with the WaterMaster EDD file.

This EDD file is available for download from the ABB website at www.abb.com/fieldbus (follow link for PROFIBUS DP field devices).

5 PROFIBUS Block Parameters

WaterMaster parameters are arranged in blocks that are formatted in accordance with PROFIBUS-PA specifications that define 3 categories of blocks: Physical Block, Transducer Block and Function Block.

Analog Input, Totalizer and Analog Output Function Blocks are used by WaterMaster – see Appendix A for PROFIBUS PA block structure diagrams.

PROFIBUS-PA blocks described in Table 5.1 are defined for WaterMaster – Fig. 5.1, page 18 shows the relationship between WaterMaster Transducer Blocks and Function Blocks.

Note.

- TOT blocks are defined by the PROFIBUS PA specification and are not the same as the WaterMaster's own internal totalizers.
- WaterMaster's own internal totalizers (AI2, AI3) should be used instead of PROFIBUS totalizer blocks (TOT1, TOT2) for custody transfer and fiscal metering applications.
- The locally displayed totalizer values have a much higher resolution and range than the internal totalizer values expressed via AI blocks. This means that the lower significance digits should be the same, allowing for limitation of floating point value accuracy, but higher significance digits may be cut off on the AI totalizer value.
- Refer to IM/WMPBST-EN for full details of PROFIBUS Block Parameters Slots 0 to 12. This manual can be downloaded from www.abb.com.

Slot	Block	Description
0	Physical Block (PB)	Standard PROFIBUS PA Physical Block parameters plus settings for profile selection, alarms and alarm history.
1	AI1 Volume Flowrate (Q)	Volumetric flow rate, that is the primary process value for the instrument.
2	TOT1 Totalizer 1	Volume totalizer. Factory-set to accumulate in the forward flow direction, but mode can be changed to suit user requirements.
3	TOT2 Totalizer 2	Volume totalizer. Factory-set to accumulate in the reverse flow direction, but mode can be changed to suit user requirements.
4	AI2 Internal Volume (FWD)	WaterMaster's internal forward flow volume totalizer. This is the same as the totalizer value displayed on the <i>Operator</i> page.
5	AI3 Internal Volume (REV)	WaterMaster's internal reverse flow volume totalizer. This is the same as the totalizer value displayed on the <i>Operator</i> page.

Table 5.1 PROFIBUS Block Parameters – Slots 0 to 12

Slot	Block	Description
6	AI4 Diagnostic Signal	Value of certain measurements used for diagnostics purposes such as electromagnetic coil resistance. The block's channel number defines the actual measurement source.
7	AO1 Display Value	Allows the master to send a process value from another instrument to be shown on the local display in addition to the WaterMaster's own process values (for example, if the remote instrument did not have its own local display).
8	TB1 Flow	Block for signal processing of process measurements. Holds similar configuration items to the <i>Device Setup</i> menu pages.
9	TB2 Device Info	Unique information about a particular instrument such as serial numbers. Holds similar configuration items to the <i>Device Info</i> menu pages.
10	TB3 Special Function	Holds similar configuration items to the <i>Totalizer</i> and <i>Input / Output</i> menu pages.
11	TB4 Display	Holds similar configuration items to the menu pages displayed on the WaterMaster.
12	TB5 Diagnostics	Block for processing of diagnostic signal measurements. Holds similar configuration items to the <i>Diagnostic</i> menu pages.

Table 5.1 PROFIBUS Block Parameters – Slots 0 to 12 (Continued)

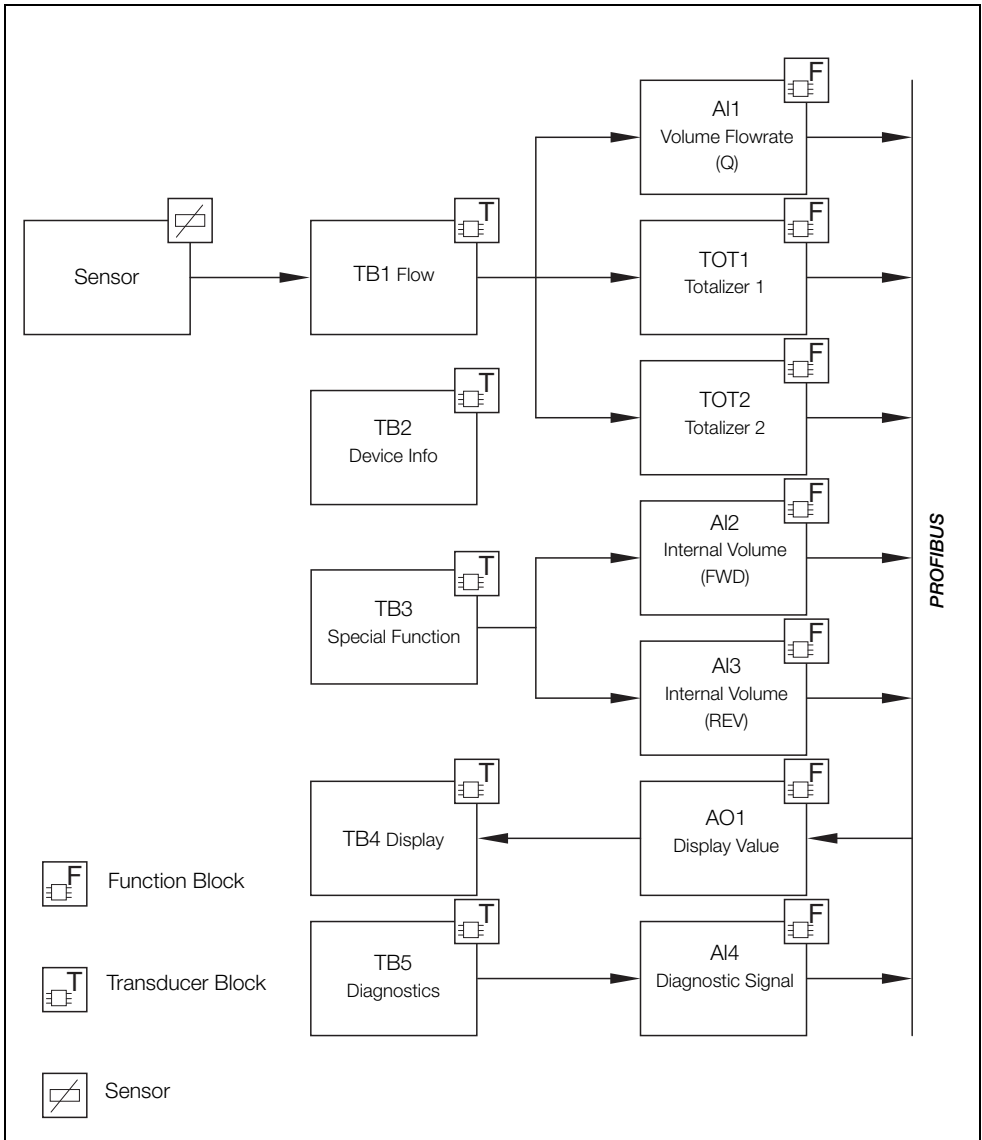

Fig. 5.1 WaterMaster Transducer and Function Block Relationships

	Supported PA Ident Numbers			
	0x3431 FEX100-DP	0x9741 Profile-specific (2AI + 1TOT)	0x9740 Profile-specific (1AI + 1TOT)	0x9700 Profile-specific (1AI)
Physical Block (PB)	Slot 0	Slot 0	Slot 0	Slot 0
AI1 Volume Flowrate (Q)	Slot 1	Slot 1	Slot 1	Slot 1
TOT1 Totalizer 1	Slot 2	Slot 2	Slot 2	–
TOT2 Totalizer 2	Slot 3	–	–	–
AI2 Internal Volume (FWD)	Slot 4	Slot 4	–	–
AI3 Internal Volume (REV)	Slot 5	–	–	–
AI4 Diagnostics	Slot 6	–	–	–
AO1 Display Value	Slot 7	–	–	–
TB1 Flow	Slot 8	Slot 8	Slot 8	Slot 8
TB2 Device Info	Slot 9	Slot 9	Slot 9	Slot 9
TB3 Special Function	Slot 10	Slot 10	Slot 10	Slot 10
TB4 Display	Slot 11	Slot 11	Slot 11	Slot 11
TB5 Diagnostics	Slot 12	Slot 12	Slot 12	Slot 12

Table 5.2 Slots used for Supported PA Ident numbers

6 Error and Warning Handling

6.1 Device Alarms

WaterMaster has two instrument-specific alarm registers: one for current alarms, the other for alarm history (latch of alarm bits that have been set since last being cleared).

These alarms are a combination of errors and warnings (as defined in IM/WMP) and are located in the *Physical Block*. The alarm history can be cleared by writing to the *Clear Alarm History* parameter of the *Physical Block*. In addition to instrument-specific alarms, each Function Block has separate error and warning registers. For testing, it is possible to simulate device-specific error and warning alarms, although the alarm history does not show simulated alarms.

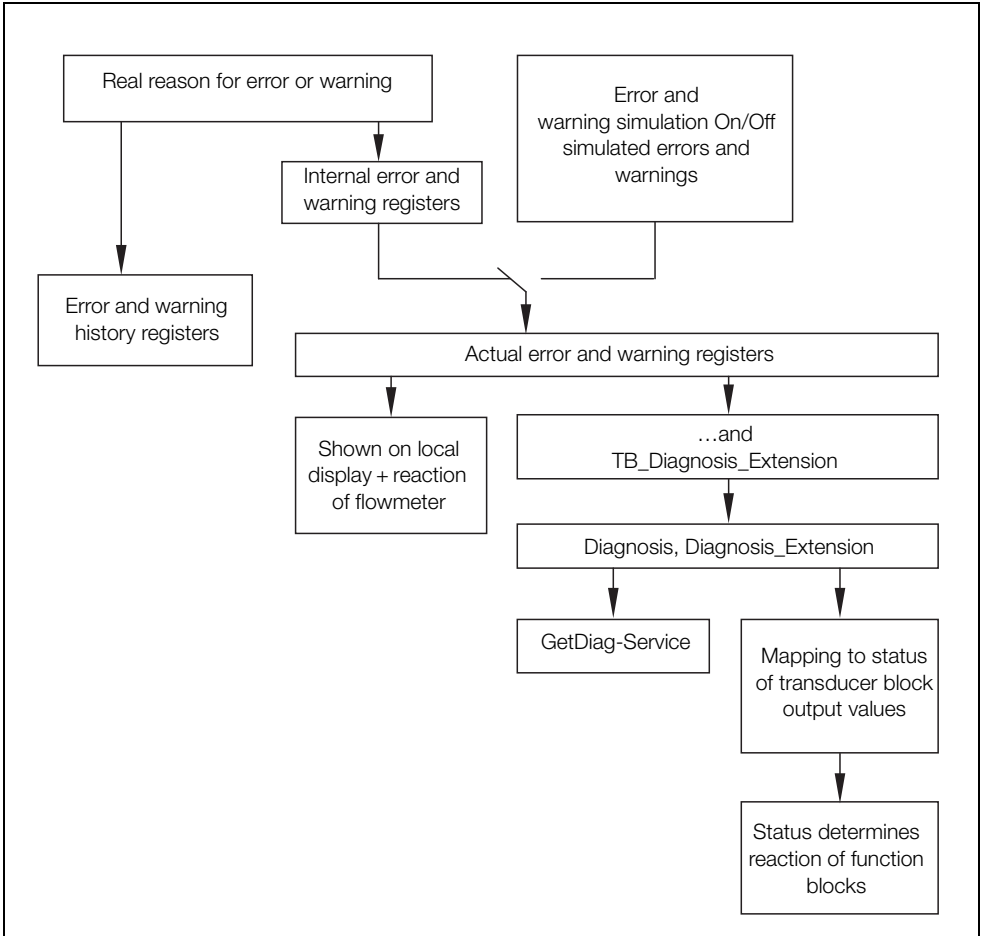

Fig. 6.1 WaterMaster Error and Warning Activities

6.2 Diagnostic Message Formats

The WaterMaster responds to diagnostics requests from the PROFIBUS master in 1 of 2 formats:

- **Short format**

The short format is sent if there are no extended diagnostic alarms that need to be signalled (when the diagnostic response Ext_Diag bit is not set). This format is the standard PROFIBUS diagnostic response of 6 bytes without extended diagnostics information.

- **Long format**

The long format is sent if extended diagnostic alarms need to be signalled (when the diagnostic response Ext_Diag bit is set). This format is the standard diagnostics information plus DPV1 extended diagnostics information.

6.3 Extended Diagnostics

The following PROFIBUS DPV1 extended diagnostic information is available, this information is always located after the standard diagnostic information (that occupies bytes 0 to 5 inclusive):

Byte	Description
6	The length of the DPV1 status message (including this byte)
7	DPV1 status type
8	Slot number (of Physical Block)
9	Specifier. The value of Bit0 and Bit1 indicate the change condition: 1 = status appears 2 = status disappears
10 to 13	4 octets DIAGNOSIS
14 to 19	6 octets DIAGNOSIS_EXTENSION

Table 6.1 PROFIBUS Parameter Descriptions

Note. Bytes 6 to 9 inclusive are defined by the DPV1 diagnostic model specification.

6.3.1 DIAGNOSIS Parameter

The DIAGNOSIS parameter is at relative index 13 of the Physical Block. The meaning of bits within the DIAGNOSIS value are defined or reserved by the application profile PROFIBUS PA version 3.01 and depend on whether extended or condensed status is enabled. Alarm status is maintained for the duration of the alarm condition, with the exception of *Warm Start* and *Cold Start* indications that reset after 10 seconds.

Extended Status

The PROFIBUS PA application profile defines a standard set of alarm status bits and is used when condensed diagnostic status is disabled. The instrument's diagnostic response Ext_Diag bit is set when any of these alarm bits are set.

Octet	Bit	Unit Diag Bit (GSD)	Description (When Bit Set)
1	0	24	Hardware failure of the electronics
	1	25	Hardware failure mechanics
	2	26	Motor temperature too high
	3	27	Electronic temperature too high
	4	28	Memory error
	5	29	Failure in measurement
	6	30	Device not initialized (no self-calibration)
	7	31	Self-calibration failed
2	0	32	Zero point error (limit position)
	1	33	Power supply failed (electrical, pneumatic)
	2	34	Configuration not valid
	3	35	Warm Start performed
	4	36	Cold Start performed
	5	37	Maintenance required
	6	38	Characterization invalid
	7	39	Ident_Number of the running cyclic data transfer and the value of Physical Block IDENT_NUMBER_SELECTOR parameter are different.
3	0 to 7	40 to 47	Reserved by PNO, fixed to 0
4	0 to 6	48 to 54	Reserved by PNO, fixed to 0
	7	55	More diagnosis information is available in DIAGNOSIS_EXTENSION

Table 6.2 DIAGNOSIS Bit Descriptions (Extended)

Condensed Status

The PROFIBUS PA application profile defines condensed status and diagnostics to:

- make diagnostic events clearer with reference to the usage in the PCS / DCS and the Maintenance Station
- indicate the need of maintenance in a graduated way
- add new required status information

When condensed diagnostic status is enabled, the instrument's diagnostic response Ext_Diag bit is set only when a failure alarm bit is set.

The following table shows condensed alarm bits as defined by the PROFIBUS PA application profile.

Octet	Bit	Unit Diag Bit (GSD)	Description (When Bit Set)
1	0 to 7	24 to 31	Reserved by PNO, fixed to 0
2	0 to 2	32 to 34	Reserved by PNO, fixed to 0
	3	35	<i>Warm Start</i> performed
	4	36	<i>Cold Start</i> performed
	5	37	Maintenance required
	6	38	Reserved by PNO, fixed to 0
	7	39	Ident_Number of the running cyclic data transfer and the value of Physical Block IDENT_NUMBER_SELECTOR parameter are different
	3	0	40
1		41	Maintenance demanded
2		42	Device is in function check mode or in simulation or under local control (for example, maintenance)
3		43	The process conditions prevent return to valid values – the value has the following quality status definitions: <ul style="list-style-type: none"> Uncertain, process related Uncertain, no maintenance Bad, process related Bad, no maintenance
4 to 7		44 to 47	Reserved by PNO, fixed to 0
4	0 to 6	48 to 54	Reserved by PNO, fixed to 0
	7	55	More diagnosis information is available in DIAGNOSIS_EXTENSION

Table 6.3 DIAGNOSIS Bit Descriptions (Extended)

6.3.2 DIAGNOSIS_EXTENSION Parameter

The DIAGNOSIS_EXTENSION parameter is at relative index 14 of the Physical Block.

WaterMaster's map device-specific diagnostic error and warning messages into bits of the DIAGNOSIS_EXTENSION. Because the standard profile Ident Numbers do not support these device-specific alarms, they are available only when the WaterMaster-specific Ident Number (3431) is used.

Octet	Bit	Unit Diag Bit (GSD)	Description (When Bit Set)
1	0	56	Unused
	1	57	Logic simulation selected on OP1
	2	58	Pulse simulation selected on OP1
	3	59	Logic simulation selected on OP1
	4	60	Pulse simulation selected on OP2
	5	61	Logic simulation selected on OP3
	6	62	Low flow alarm
	7	63	High flow alarm
2	0	64	Q > 103% Qmax
	1	65	Simulation mode on
	2	66	Tx. simulator / calibrator mode
	3	67	At Qmax, volume display overrun <1600 hours
	4	68	Totalizer reset
	5	69	Intermittent sensor comms
	6	70	Unused
	7	71	Tx. memory fault detected
3	0	72	Sensor memory not detected
	1	73	Tx. measurement suspended
	2	74	Empty pipe
	3	75	Unused
	4	76	Unused
	5	77	Open circuit electrode
	6	78	Short circuit electrode
	7	79	Unused

Table 6.4 DIAGNOSIS Bit Descriptions – Extended

Octet	Bit	Unit Diag Bit (GSD)	Description (When Bit Set)
4	0	80	Installation fault / condition
	1	81	Open circuit coil / wiring
	2	82	Short circuit coil / wiring
	3	83	Check cable + coil resistance
	4	84	Transmitter hardware fault
	5	85	Bad flow data
	6	86	Accuracy warning
	7	87	OIML self-check limits exceeded
5	0	88	Measurement starting
	1	89	Unused
	2	90	Sensor setup not complete
	3	91	Incompatible sensor
	4	92	Tx. code memory fault
	5	93	Tx. data memory fault
	6	94	Unused
	7	95	Alarm simulation active
6	0	96	Non-volatile summary alarm
	1 to 7	97 to 103	Unused

Table 6.4 DIAGNOSIS Bit Descriptions – Extended (Continued)

6.4 Mapping Alarms to Transducer Block Status

Transducer Blocks deliver measurement values to their corresponding Function Blocks in a data structure (PROFIBUS data type structure 101) containing the measurement value plus a status code to indicate the quality of the measurement value.

WaterMasters have three diagnostic groups that affect the measurement value status of the associated Transducer Block channels and the Function Blocks connected to them when error or warning bits are set – these are defined in Table 6.5.

Diagnostic Group	TB Channels Affected	FBs Affected
0	VOLUME_FLOWRATE	AI1, TOT1, TOT2
1	VOLUME_FORWARD,VOLUME_REVERSE	AI2, AI3
2	ELECTRODE_1_RESISTANCE ELECTRODE_2_RESISTANCE BACK_OFF_VOLTAGE COIL_AND_CABLE_RESISTANCE COIL_INDUCTANCE SENSOR_INDUCTANCE_SHIFT TRANSMITTER_AVERAGE_GAIN_SHIFT	AI4

Table 6.5 Diagnostic Group TB Channels

6.4.1 Extended Status Tables

The following tables define how set alarm bits affect the measurement status of the corresponding Transducer Block channels for extended status (refer to the PROFIBUS PA application profile specification for more details on these definitions).

Octet	Bit	Unit Diag Bit (GSD)	Description (When Bit Set)	Diagnostic Group 0	Diagnostic Group 1	Diagnostic Group 2
1	0	56	Unused			
	1	57	Logic simulation selected on OP1	GOOD(NC)	GOOD(NC)	GOOD(NC)
	2	58	Pulse simulation selected on OP1	GOOD(NC)	GOOD(NC)	GOOD(NC)
	3	59	Logic simulation selected on OP1	GOOD(NC)	GOOD(NC)	GOOD(NC)
	4	60	Pulse simulation selected on OP2	GOOD(NC)	GOOD(NC)	GOOD(NC)
	5	61	Logic simulation selected on OP3	GOOD(NC)	GOOD(NC)	GOOD(NC)
	6	62	Low flow alarm	GOOD(NC), low limited	GOOD(NC), low limited	GOOD(NC), low limited
	7	63	High flow alarm	GOOD(NC), high limited	GOOD(NC), high limited	GOOD(NC), high limited
2	0	64	Q > 103% Qmax	GOOD(NC), high limited	GOOD(NC), high limited	GOOD(NC), high limited

Table 6.6 Alarm Mapping for Extended Status

Octet	Bit	Unit Diag Bit (GSD)	Description (When Bit Set)	Diagnostic Group 0	Diagnostic Group 1	Diagnostic Group 2
	1	65	Simulation mode on	UNCERTAIN, simulated value	UNCERTAIN, simulated value	GOOD(NC)
	2	66	Tx. simulator / calibrator mode	UNCERTAIN, simulated value	UNCERTAIN, simulated value	GOOD(NC)
	3	67	At Qmax, volume display overrun <1600 hours	GOOD(NC)	GOOD(NC)	GOOD(NC)
	4	68	Totalizer reset	GOOD(NC)	GOOD(NC)	GOOD(NC)
	5	69	Intermittent sensor comms	GOOD(NC), maintenance required	GOOD(NC), maintenance required	GOOD(NC), maintenance required
	6	70	Unused			
	7	71	Tx. memory fault detected	BAD, device failure	BAD, device failure	BAD, device failure
3	0	72	Sensor memory not detected	BAD, device failure	BAD, device failure	BAD, device failure
	1	73	Tx. measurement suspended	BAD, device failure	BAD, device failure	BAD, device failure
	2	74	Empty pipe	UNCERTAIN, non-specific	UNCERTAIN, non-specific	UNCERTAIN, non-specific
	3	75	Unused			
	4	76	Unused			
	5	77	Open circuit electrode	UNCERTAIN, non-specific	UNCERTAIN, non-specific	UNCERTAIN, non-specific
	6	78	Short circuit electrode	UNCERTAIN, non-specific	UNCERTAIN, non-specific	UNCERTAIN, non-specific
	7	79	Unused			

Table 6.6 Alarm Mapping for Extended Status (Continued)

Octet	Bit	Unit Diag Bit (GSD)	Description (When Bit Set)	Diagnostic Group 0	Diagnostic Group 1	Diagnostic Group 2
4	0	80	Installation fault / condition	BAD, device failure	BAD, device failure	BAD, device failure
	1	81	Open circuit coil / wiring	BAD, device failure	BAD, device failure	BAD, device failure
	2	82	Short circuit coil / wiring	BAD, device failure	BAD, device failure	BAD, device failure
	3	83	Check cable and coil resistance	BAD, device failure	BAD, device failure	BAD, device failure
	4	84	Transmitter hardware fault	BAD, device failure	BAD, device failure	BAD, device failure
	5	85	Bad flow data	BAD, device failure	BAD, device failure	BAD, device failure
	6	86	Accuracy warning	UNCERTAIN, non-specific	UNCERTAIN, non-specific	UNCERTAIN, non-specific
	7	87	OIML self-check limits exceeded	GOOD(NC), maintenance required	GOOD(NC), maintenance required	GOOD(NC), maintenance required
5	0	88	Measurement starting	UNCERTAIN, non-specific	UNCERTAIN, non-specific	UNCERTAIN, non-specific
	1	89	Unused			
	2	90	Sensor setup not complete	UNCERTAIN, non specific	UNCERTAIN, non specific	UNCERTAIN, non specific
	3	91	Incompatible sensor	BAD, device failure	BAD, device failure	BAD, device failure
	4	92	Tx. code memory fault	BAD, device failure	BAD, device failure	BAD, device failure
	5	93	Tx. data memory fault	BAD, device failure	BAD, device failure	BAD, device failure
	6	94	Unused			
	7	95	Alarm simulation active	GOOD(NC)	GOOD(NC)	GOOD(NC)
6	0	96	Non-volatile summary alarm	BAD, device failure	BAD, device failure	BAD, device failure
	1 to 7	97 to 103	Unused			

Table 6.6 Alarm Mapping for Extended Status (Continued)

For extended status, the status value is formatted into several fields and is defined in Table 6.7:

Bit 7	Bit 6	Bit 5	Bit 4	Bit 3	Bit 2	Bit 1	Bit 0
Quality		Quality Sub Status				Limits	

Table 6.7 Status Value Field Formats

0	BAD – the value is not useful.
1	UNCERTAIN – the quality of the value is less than normal, but the value may still be useful.
2	GOOD (non-cascade / NC) – the quality of the value is good. Possible alarm conditions may be indicated by the sub-status.
3	GOOD (cascade / C) – the value can be used in control.

Table 6.8 Quality

0	Non-specific
1	Configuration error
2	Not connected
3	Device failure
4	Sensor failure
5	No communication (last usable value)
6	No communication (no usable value)
7	Out-of-service

Table 6.9 Quality Sub Status for BAD

0:	Non specific
1:	Last usable value (LUV)
2	Substitute value
3	Initial value
4	Sensor conversion not accurate
5	Engineering unit violation
6	Sub normal
7	Configuration error
8	Simulated value
9	Sensor calibration

Table 6.10 Quality Sub Status for UNCERTAIN

0	OK
1	Update event
2	Active advisory alarm
3	Active critical alarm
4	Unacknowledged update event
5	Unacknowledged advisory alarm
6	Unacknowledged critical alarm
7	–
8	Initiate fail-safe
9	Maintenance required

Table 6.11 Quality Sub Status for GOOD (Non-cascade)

0	OK
1	Initialisation acknowledged
2	Initialisation request
3	Not invited
4	Reserved
5	Do not select
6	Local override

Table 6.12 Quality Sub Status for GOOD (Cascade)

0	OK
1	Low limited
2	High limited
3	Constant

Table 6.13 Limits

6.4.2 Condensed Status Tables

Tables to 6.14 to 6.20 (page 37)define how set alarm bits affect the measurement status of the corresponding Transducer Block channels for condensed status (refer to the PROFIBUS PA application profile specification for more details on these definitions).

Octet	Bit	Unit Diag Bit (GSD)	Description (When Bit Set)	Diagnostic Group 0	Diagnostic Group 1	Diagnostic Group 2
1	0	56	Unused			
	1	57	Logic simulation selected on OP1	GOOD(G)	GOOD(G)	GOOD(G)
	2	58	Pulse simulation selected on OP1	GOOD(G)	GOOD(G)	GOOD(G)
	3	59	Logic simulation selected on OP1	GOOD(G)	GOOD(G)	GOOD(G)
	4	60	Pulse simulation selected on OP2	GOOD(G)	GOOD(G)	GOOD(G)
	5	61	Logic simulation selected on OP3	GOOD(G)	GOOD(G)	GOOD(G)
	6	62	Low flow alarm	GOOD critical alarm, low limit	GOOD critical alarm, low limit	GOOD critical alarm, low limit
	7	63	High flow alarm	GOOD-critical alarm, high limit	GOOD-critical alarm, high limit	GOOD-critical alarm, high limit
2	0	64	Q > 103% Qmax	GOOD-critical alarm, high limit	GOOD-critical alarm, high limit	GOOD-critical alarm, high limit
	1	65	Simulation mode on	Check(C)	Check(C)	Good(G)
	2	66	Tx. simulator / calibrator mode	Check(C)	Check(C)	Good(G)
	3	67	At Qmax, volume display overrun <1600 hours	GOOD(G)	GOOD(G)	GOOD(G)
	4	68	Totalizer reset	GOOD(G)	GOOD(G)	GOOD(G)
	5	69	Intermittent sensor comms	Maintenance(M)	Maintenance(M)	Maintenance(M)
	6	70	Unused			
	7	71	Tx. memory fault detected	Failure(F)	Failure(F)	Failure(F)

Table 6.14 Alarm Mapping for Extended Status

Octet	Bit	Unit Diag Bit (GSD)	Description (When Bit Set)	Diagnostic Group 0	Diagnostic Group 1	Diagnostic Group 2
3	0	72	Sensor memory not detected	Failure(F)	Failure(F)	Failure(F)
	1	73	Tx. measurement suspended	Failure(F)	Failure(F)	Failure(F)
	2	74	Empty pipe	Out of Specification(S)	Out of Specification(S)	Out of Specification(S)
	3	75	Unused			
	4	76	Unused			
	5	77	Open circuit electrode	Out of Specification(S)	Out of Specification(S)	Out of Specification(S)
	6	78	Short circuit electrode	Out of Specification(S)	Out of Specification(S)	Out of Specification(S)
	7	79	Unused			
4	0	80	Installation fault / condition	Failure(F)	Failure(F)	Failure(F)
	1	81	Open circuit coil / wiring	Failure(F)	Failure(F)	Failure(F)
	2	82	Short circuit coil / wiring	Failure(F)	Failure(F)	Failure(F)
	3	83	Check cable + coil resistance	Failure(F)	Failure(F)	Failure(F)
	4	84	Transmitter hardware fault	Failure(F)	Failure(F)	Failure(F)
	5	85	Bad flow data	Failure(F)	Failure(F)	Failure(F)
	6	86	Accuracy warning	Out of Specification(S)	Out of Specification(S)	Out of Specification(S)
	7	87	OIML self-check limits exceeded	Maintenance(M)	Maintenance(M)	Maintenance(M)

Table 6.14 Alarm Mapping for Extended Status (Continued)

Octet	Bit	Unit Diag Bit (GSD)	Description (When Bit Set)	Diagnostic Group 0	Diagnostic Group 1	Diagnostic Group 2
5	0	88	Measurement starting	Out of Specification(S)	Out of Specification(S)	Out of Specification(S)
	1	89	Unused			
	2	90	Sensor setup not complete	Out of Specification(S)	Out of Specification(S)	Out of Specification(S)
	3	91	Incompatible sensor	Failure(F)	Failure(F)	Failure(F)
	4	92	Tx. code memory fault	Failure(F)	Failure(F)	Failure(F)
	5	93	Tx. data memory fault	Failure(F)	Failure(F)	Failure(F)
	6	94	Unused			
	7	95	Alarm simulation active	Good(G)	Good(G)	Good(G)
6	0	96	Non-volatile summary alarm	Failure(F)	Failure(F)	Failure(F)
	1 to 7	97 to 103	Unused			

Table 6.14 Alarm Mapping for Extended Status (Continued)

Condensed status values are formatted into several fields defined and is defined in Table 6.15:

Bit 7	Bit 6	Bit 5	Bit 4	Bit 3	Bit 2	Bit 1	Bit 0
Quality		Quality Sub-status				Limits	

Table 6.15 Status Value Field Formats

NE107 Meaning	PCS / DCS usage	Coding				PROFIBUS-PA meaning
		Quality	Sub Status	Limits		
Failure(F)	Failure	0 0	1 0 0 1	X X	0x24 to 0x27	BAD maintenance alarm, more diagnosis available
Check(C)	Failure	0 0	1 1 1 1	X X	0x3C to 0x3F	BAD function check / local override
Out of specification(S)	Uncertain	0 1	1 1 1 0	X X	0x78 to 0x7B	UNCERTAIN process related, no maintenance
Maintenance(M)	Good	1 0	1 0 0 1 1 0 1 0	X X	0xA4 to 0xA8	GOOD maintenance required / demanded

Table 6.16 Coding of the Condensed Status Restricted to NE107

NE107 Meaning	PCS / DCS usage	Coding				PROFIBUS-PA meaning
		Quality	Sub Status	Limits		
Good(G)	Good	1 0	0 0 0 0	0 0	0x80	GOOD ok
Good(G)	Good	1 0	0 0 0 1	X X	0x84 to 0x87	GOOD update event
Good(G)	Good	1 0	0 0 1 0	0 1	0x89	GOOD advisory alarm, low limit
Good(G)	Good	1 0	0 0 1 0	1 0	0x8A	GOOD advisory alarm, high limit
Good(G)	Good	1 0	0 0 1 1	0 1	0x8D	GOOD critical alarm, low limit
Good(G)	Good	1 0	0 0 1 1	1 0	0x8E	GOOD critical alarm, high limit

Table 6.17 Coding of Limit Checks / Update Events for Quality GOOD

NE107 Meaning	PCS / DCS usage	Maintenance Station Usage	Coding				PROFIBUS-PA meaning
			Quality	Sub Status	Limits		
Failure(F)	Failure	Failure	0 0	0 0 0 0	0 0	0x00	BAD non-specific
Failure(F)	Passivated	Good	0 0	1 0 0 0	1 1	0x23	BAD passivated (diagnostic alerts inhibited)
Failure(F)	Failure	Maintenance alarm	0 0	1 0 0 1	X X	0x24 to 0x27	BAD maintenance alarm, more diagnosis available
Failure(F)	Failure	Good	0 0	1 0 1 0	X X	0x28 to 0x2B	BAD process related, no maintenance
Check(C)	Function check	Function check	0 0	1 1 1 1	X X	0x3C to 0x3F	BAD function check / local override, value not usable

Table 6.18 Detailed Coding of the Condensed Status – Quality BAD

NE107 Meaning	PCS / DCS usage	Maintenance Station Usage	Coding				PROFIBUS-PA meaning
			Quality	Sub Status	Limits		
Failure(F)	Uncertain	Maintenance alarm	0 1	0 0 1 0	1 1	0x4B	UNCERTAIN substitute set
Failure(F)	Uncertain	Good	0 1	0 0 1 1	1 1	0x4F	UNCERTAIN initial value
Maintenance(M)	Uncertain	Maintenance demanded	0 1	1 0 1 0	X X	0x68 to 0x6B	UNCERTAIN maintenance demanded
Check(C)	Uncertain	Function check	0 1	1 1 0 0	1 1	0x73	UNCERTAIN simulated value, start
Check(C)	Uncertain	Good	0 1	1 1 0 1	X X	0x74 to 0x77	UNCERTAIN simulated value, end
Out of specification(S)	Uncertain	Good	0 1	1 1 1 0	X X	0x78 to 0x7B	UNCERTAIN process related, no maintenance

Table 6.19 Detailed Coding of the Condensed Status – Quality UNCERTAIN

NE107 Meaning	PCS / DCS usage	Maintenance Station Usage	Coding				PROFIBUS-PA meaning
			Quality	Sub Status	Limits		
Good(G)	Good	Good	1 0	0 0 X X	X X	0x80 to 0x8E	GOOD
Good(G)	Good	Good	1 0	1 0 0 0	X X	0xA0 to 0xA3	GOOD initiate fail safe
Maintenance(M)	Good	Maintenance required	1 0	1 0 0 1	X X	0xA4 to 0xA7	GOOD maintenance required
Maintenance(M)	Good	Maintenance demanded	1 0	1 0 1 0	X X	0xA8 to 0xAB	GOOD maintenance demanded
Good(G)	Good	Function check	1 0	1 1 1 1	X X	0xBC to 0xBF	GOOD function check

Table 6.20 Detailed Coding of the Condensed Status – Quality GOOD

7 Identification and Maintenance

PROFIBUS DPV1 specifies functionality for Identification and Maintenance services (I&M) that allow information about an instrument to be requested via bus in a standard format.

WaterMaster flowmeters support the following standard I&M functions (as the mandatory requirements of PROFIBUS PA application profile version 3.01):

- I&M0
- I&M1
- I&M2
- I&M3
- profile-specific function PA_I&M0

All of these functions are available with read-only access from parameter slot 0. I&M functions are not available for the other parameter slots.

Note. Unless otherwise stated, reserved parameters have their data value set to 0x00 for numerical values or all characters set to ASCII 0x20 (space) for text values.

Parameter		Description
0	HEADER	Reserved.
1	MANUFACTURER_ID	PROFIBUS manufacturer code for ABB (0x1A – as DEVICE_MAN_ID parameter in PB).
2	ORDER_ID	Fixed to '9AAC133129' that is the ABB catalogue ID for WaterMaster flowmeters. This can be used to create a web query for locating information about the device on the ABB website: www.abb.com
3	SERIAL_NUMBER	Serial number of the device – as DEVICE_SER_NUM parameter in PB.
4	HARDWARE_REVISION	Fixed to 0xFF, 0xFF (to indicate profile-specific information).
5	SOFTWARE_REVISION	Fixed to 'V', 0xFF, 0xFF, 0xFF (to indicate profile-specific information).
6	REV_COUNTER	Incremental change count for any static data in any block (PB, TB or FB).

Table 7.1 Function: I&M0

Parameter		Description
7	PROFILE_ID	Fixed to 0x9700, indicating device supporting PROFIBUS PA profile.
8	PROFILE_SPECIFIC_TYPE	Byte 0 – BlockObject type code for the block of slot being accessed (PB gives value 0x01). Byte 1 – ParentClass type code for the block of slot being accessed (PB gives value 0x01 [transmitter]).
9	IM_VERSION	Fixed to 0x01, 0x01 (indicating I&M version 1.1).
10	IM_SUPPORTED	Fixed to 0x00, 0x0F (indicating I&M0 to I&M3 supported).

Table 7.1 Function: I&M0 (Continued)

Parameter		Description
0	HEADER	Reserved.
1	TAG_FUNCTION	Same as the TAG parameter in PB.
2	TAG_FUNCTION	Filled with ASCII 0x20 (space) characters.

Table 7.2 Function: I&M1

Parameter		Description
0	HEADER	Reserved.
1	DATE	Same as the DEVICE_INSTALL_DATE parameter in PB.
2	Reserved	Reserved.

Table 7.3 Function: I&M2

Parameter		Description
0	HEADER	Reserved.
1	DESCRIPTOR	Same as the DESCRIPTOR parameter in PB.

Table 7.4 Function: I&M3

Parameter		Description
0	HEADER	Reserved.
1	PA_IM_VERSION	Fixed to 0x01, 0x00 (version 1.0)
2	HARDWARE_REVISION	Same as HARDWARE_REVISION in PB.
3	SOFTWARE_REVISION	Same as SOFTWARE_REVISION in PB.
4	Reserved	Reserved.
5	PA_IM_SUPPORTED	Fixed to 0x00, 0x00 (no manufacturer-specific I&M data).

Table 7.5 Function: PA_I&M0

Note.

- In the event of a WaterMaster transmitter electronics fault, most problems can be fixed by replacing the cartridge with a new one. For other transmitter faults contact ABB customer support.
- Parameter data held in the sensor (such as the internal totalizer values and sensor calibration settings) are uploaded into the new cartridge at next power-up.
- The PROFIBUS Totalizer Block totals (TOT1.TOTAL and TOT2.TOTAL) are held only in the cartridge. These need to be re-written back into the WaterMaster via the bus after the new cartridge has been fitted.

Appendix A – PROFIBUS-PA Block Structure Diagrams

The following diagrams illustrate the relationship and data flow in PROFIBUS PA Function Blocks and Flow Transducer Block used in WaterMaster.

A.1 Analog Input Function Block

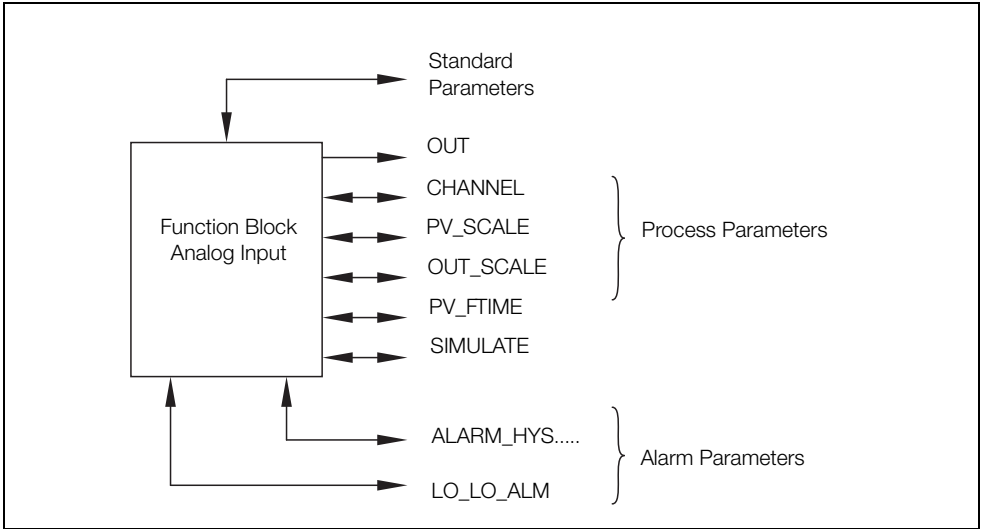

Fig. A.1 AI Block Summary

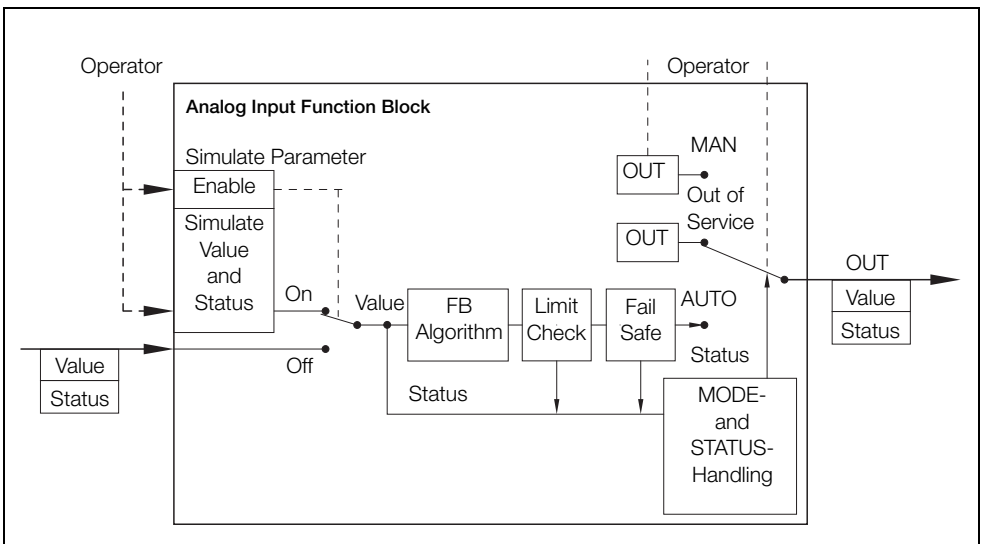

Fig. A.2 AI Block Structure

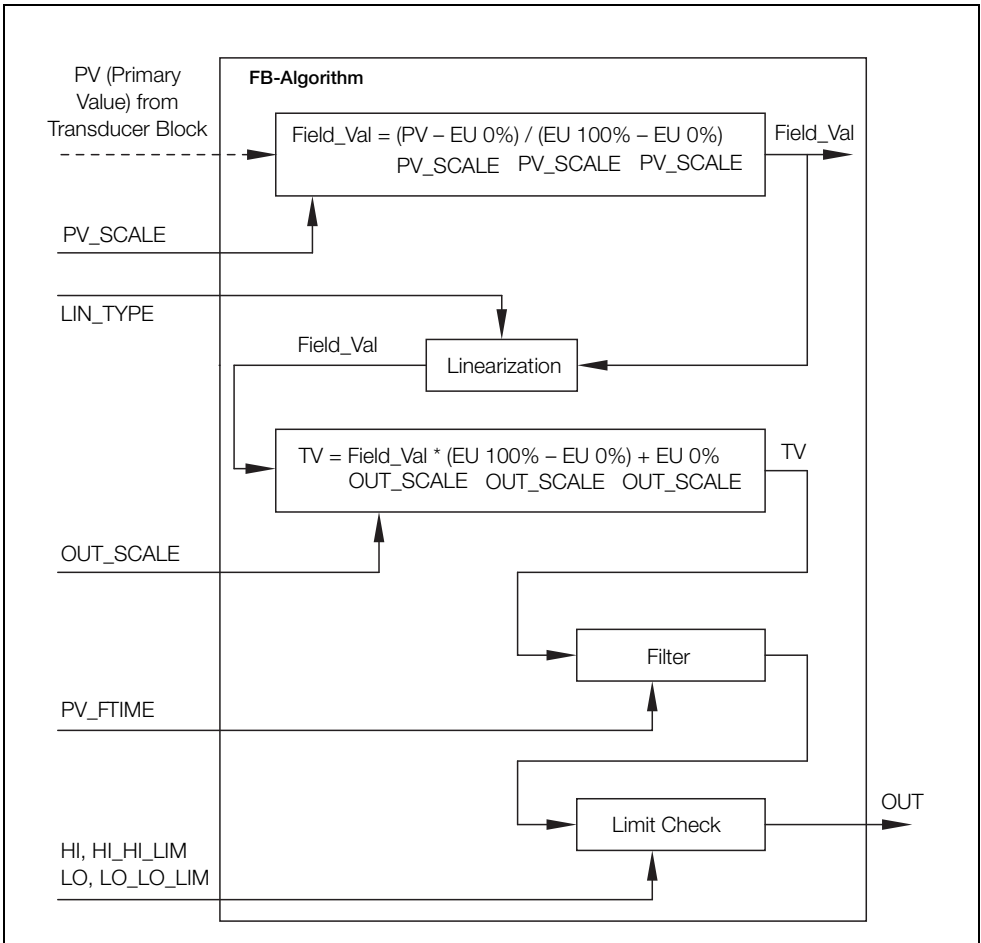

Fig. A.3 AI Block Algorithm

A.2 Totalizer Function Block

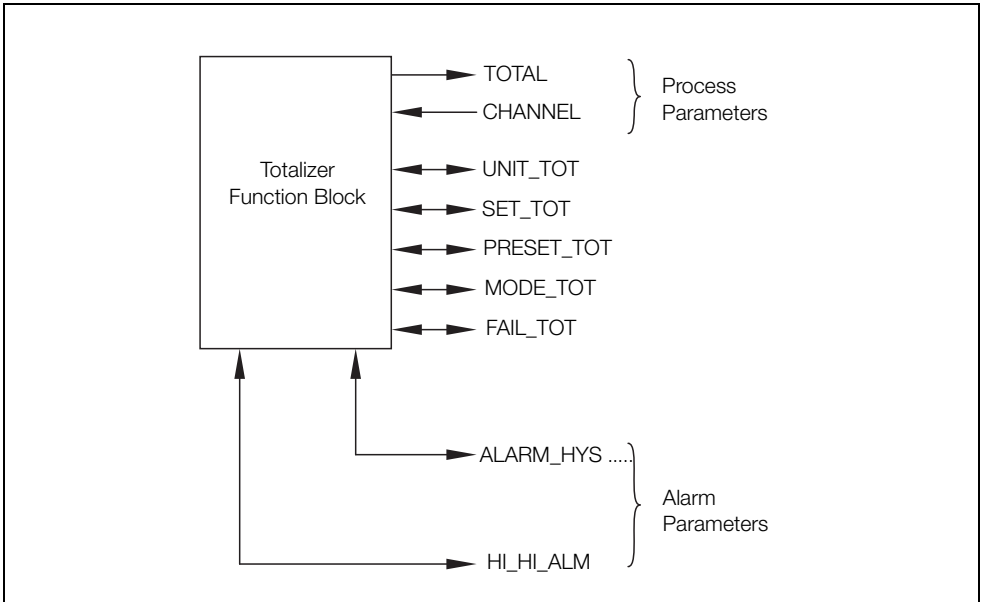

Fig. A.4 TOT Block Summary

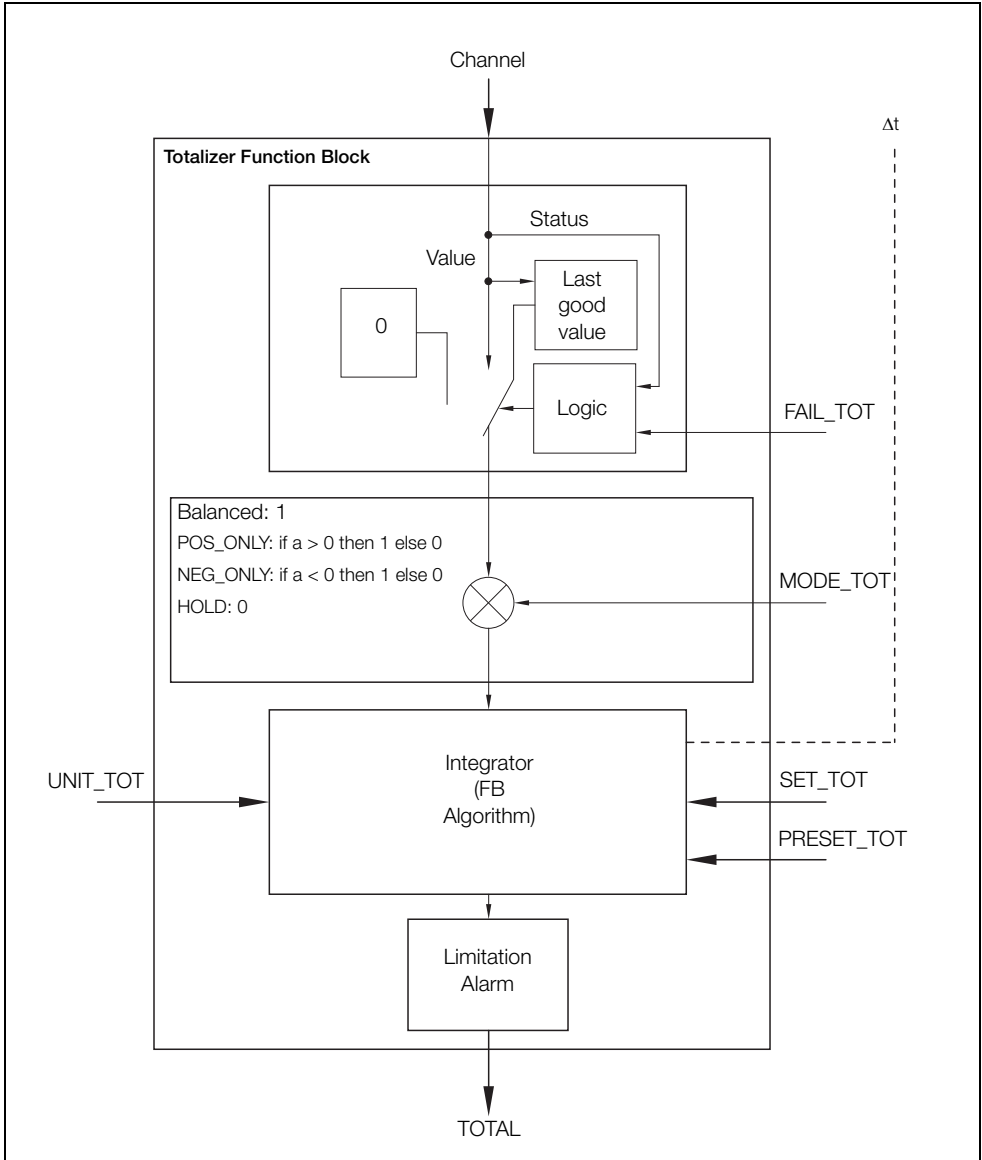

Fig. A.5 TOT Block Structure

A.3 Analog Output Function Block

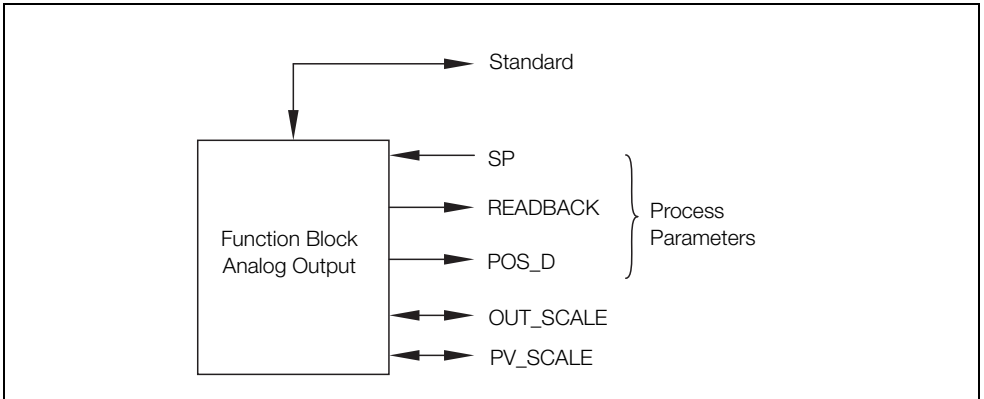

Fig. A.6 AO Block Summary

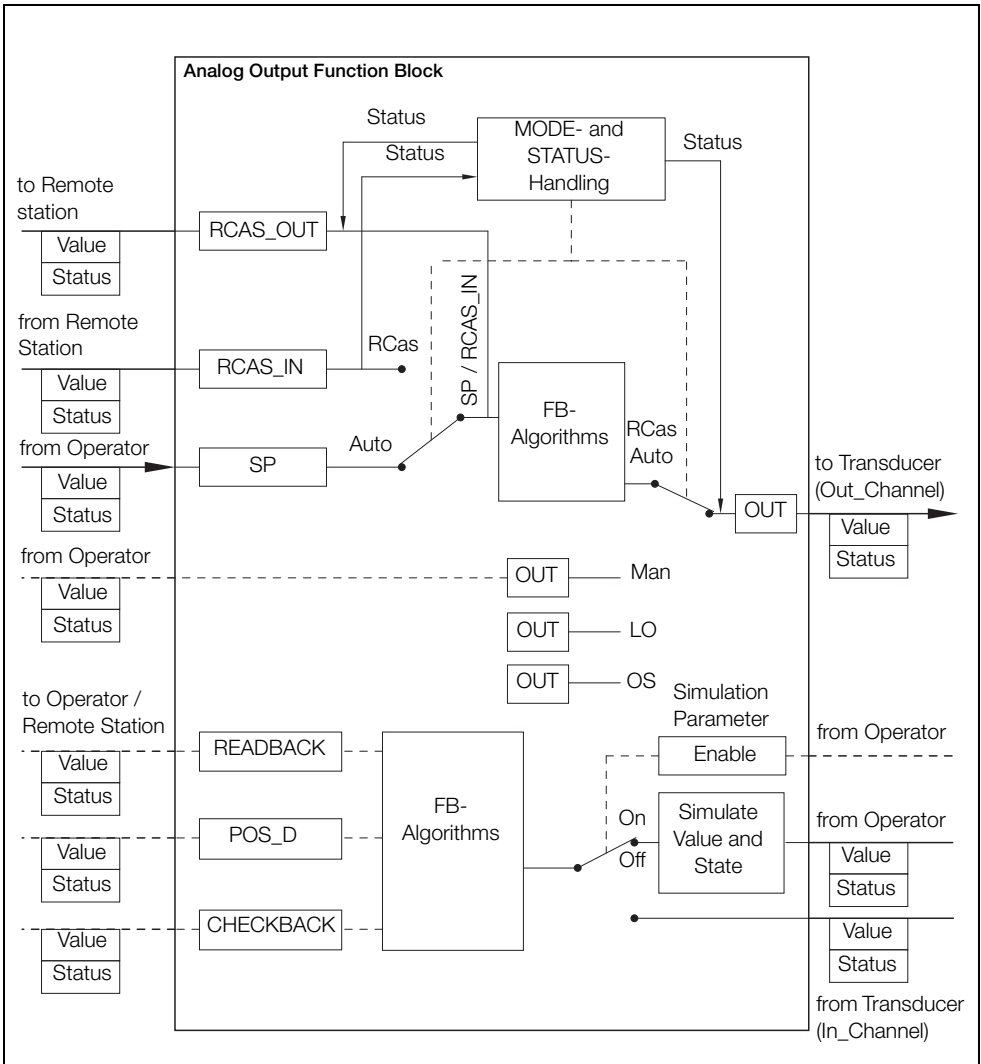

Fig. A.7 AO Block Structure

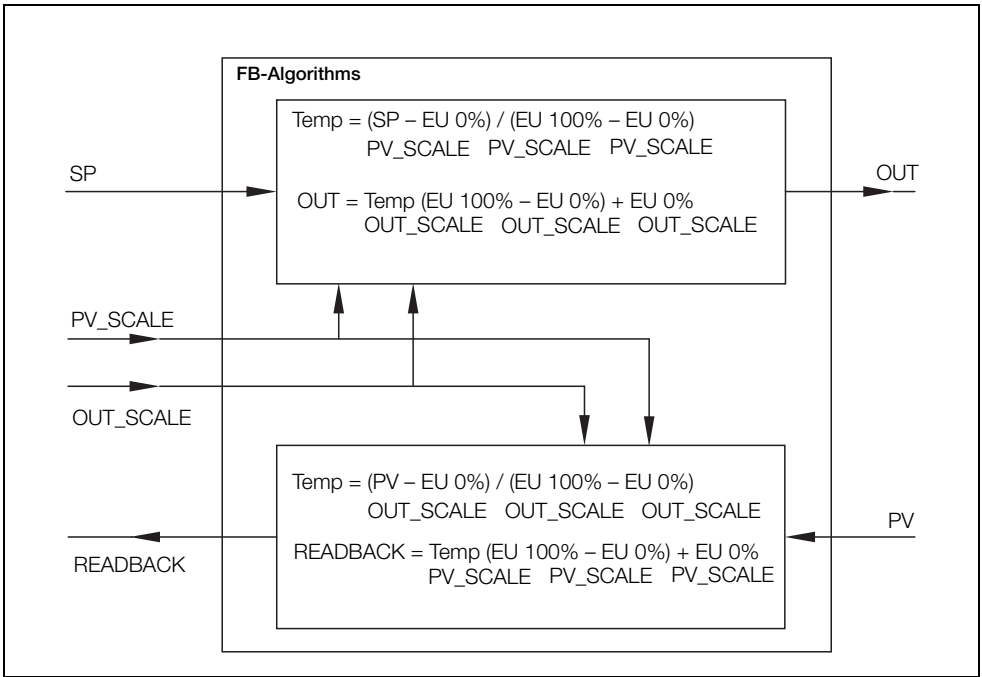

Fig. A.8 AO Block Algorithm

A.4 Flow Transducer Block

The Flow Transducer Block describes the basic set of parameters for flow devices.

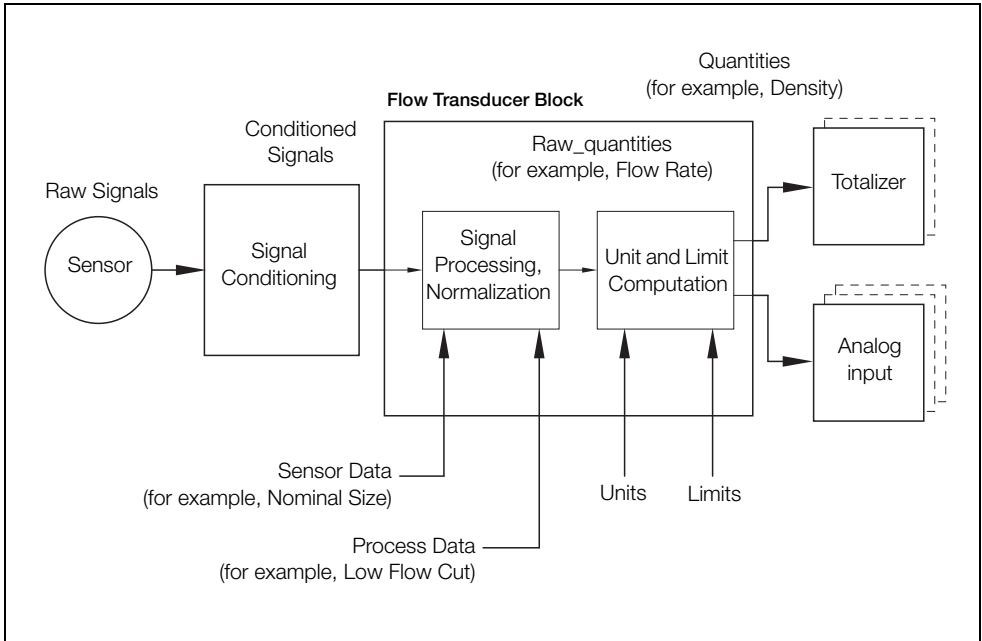

Fig. A.9 TB Flow Functional Diagram

Appendix B – PROFIBUS Data Structures

The following PROFIBUS and WaterMaster specific data structures are used in the WaterMaster blocks.

E	Element Name	Data Type	Size
1	Reserved	Unsigned8	1
2	Block_Object	Unsigned8	1
3	Parent_Class	Unsigned8	1
4	Class	Unsigned8	1
5	DD_Reference	Unsigned32	4
6	DD_Revision	Unsigned16	2
7	Profile	OctetString	2
8	Profile_Revision	Unsigned8	1
9	Execution_Time	Unsigned16	2
10	Number_of_Parameters	Unsigned16	2
11	Address_of_View_1	Unsigned16	2
12	Number_of_Views	Unsigned8	1

Table B.1 DS-32 Block Structure

E	Element Name	Data Type	Size
1	Value	Float	4
2	Status	Unsigned8	1

Table B.2 101 (Value and Status Float Structure)

E	Element Name	Data Type	Size
1	EU_at_100%	Float	4
2	EU_at 0%	Float	4
3	Units_Index	Unsigned16	2
4	Decimal_Point	Unsigned8	1

Table B.3 DS-36 (Scaling Structure)

E	Element Name	Data Type	Size
1	Actual	Unsigned8	1
2	Permitted	Unsigned8	1
3	Normal	Unsigned8	1

Table B.4 DS-37 (Mode Structure)

E	Element Name	Data Type	Size
1	Unacknowledged	Unsigned8	1
2	Alarm_State	Unsigned8	1
3	Time_Stamp	TimeValue	8
4	Subcode	Unsigned16	1
5	Value	Float	4

Table B.5 DS-39 (Alarm Float Structure)

E	Element Name	Data Type	Size
1	Current	OctetString	2
2	Unacknowledged	OctetString	2
3	Unreported	OctetString	2
4	Disabled	OctetString	2

Table B.6 DS-42 (Alarm Summary Structure)

E	Element Name	Data Type	Size
1	Simulate_Status	Unsigned8	1
2	Simulate_Value	Float	4
3	Simulate_Enabled	Unsigned8	1

Table B.7 DS-50 (Simulation Float Structure)

E	Element Name	Data Type	Size
1	Batch_ID	Unsigned32	4
2	Rup	Unsigned16	2
3	Operation	Unsigned16	2
4	Phase	Unsigned16	2

Table B.8 DS-67 (Batch Structure)

E	Element Name	Data Type	Size
1	Supported	OctetString	4
2	Enabled	OctetString	4

Table B.9 DS-68 (Feature Structure)

E	Element Name	Data Type	Size
1	Alarm_Counter	Unsigned16	2
2	Alarm_Time_Counter_Msec	Unsigned32	4
3	Alarm_Time_Counter_Day	Unsigned16	2
4	Time_Stamp_Last_Alarm_Msec	Unsigned32	4
5	Time_Stamp_Last_Alarm_Day	Unsigned16	2

Table B.10 WaterMaster Diagnosis Information Structure

Appendix C – FEX100-DP PROFIBUS Datasheet

Item	Detail
PROFIBUS device name	FEX100-DP
Applicable standards	IEC61158 (Type 3) IEC61784 (CPF3/1)
Protocols supported	PROFIBUS-DP (DPV0) PROFIBUS-DP extensions (DPV1)
Application profile	Process Control Devices version 3.01 (PROFIBUS-PA)
Profile ident support	Standard: 9700, 9740, 9741 Device specific: 3431 (4xAI, 2xTOT, 1xAO)
PROFIBUS unit type	PROFIBUS DPV1 Slave
PROFIBUS media type	RS485 (EIA-485), galvanically isolated
PROFIBUS bus connection	Wiring terminals A1/B1 (in) and A2/B2 (out)
Bus address range	1 to 126 via local display interface 1 to 125 via Set_Slave_Addr service
Baud rates supported	9.6 kbps 19.2 kbps 45.45 kbps 93.75 kbps 187.5 kbps 500 kbps 1.5 Mbps
Master Class 1 – Slave cyclic services (MS0)	Set_Prm Chk_Cfg Set_Slave_Addr Data_Exchange Get_Diag Global-Control (SYNC / UNSYNC, FREEZE / UNFREEZE, CLEAR) Get_Cfg Rd_Inp Rd_Outp
Master Class 1 – Slave acyclic services (MS1)	MS1_Read MS1_Write

Table C.1 PROFIBUS Datasheet

Item	Detail
Master Class 2 – Slave acyclic services (MS2)	3 concurrent MS2 connections MS2_Initiate MS2_Read MS2_Write MS2_Abort MS2_DataTransport MS2_Idle
Device-specific GSD file	ABB_3431.gsd
Configuration support	EDD, DTM, local display interface

Table C.1 PROFIBUS Datasheet (Continued)

Appendix D – Declaration of PROFIBUS Conformance

FEX100-DP is the PNO registered model name for PROFIBUS-enabled WaterMaster flowmeters (RS485 physical layer) approved by an independent authorized certification laboratory for connection and use in PROFIBUS networks.

Certification of PROFIBUS specification conformance covers the following areas:

- n RS485 bus interface electrical characteristics.
- n DPV0 and DPV1 protocol services.
- n Process Control Devices Profile version 3.01 (also known as the PA Profile).
- n FEX100-DP device specific GSD file.

A copy of the conformance certificate is available for download from the WaterMaster product pages of the ABB website www.abb.com.

Products and customer support

Automation Systems

For the following industries:

- Chemical & Pharmaceutical
- Food & Beverage
- Manufacturing
- Metals and Minerals
- Oil, Gas & Petrochemical
- Pulp and Paper

Drives and Motors

- AC and 6 Drives, AC and DC Machines, AC Motors to 1kV
- Drive Systems
- Force Measurement
- Servo Drives

Controllers & Recorders

- Single and Multi-loop Controllers
- Circular Chart and Strip Chart Recorders
- Paperless Recorders
- Process Indicators

Flexible Automation

- Industrial Robots and Robot Systems

Flow Measurement

- Electromagnetic Flowmeters
- Mass Flowmeters
- Turbine Flowmeters
- Wedge Flow Elements

Marine Systems & Turbochargers

- Electrical Systems
- Marine Equipment
- Offshore Retrofit and Refurbishment

Process Analytics

- Process Gas Analysis
- Systems Integration

Transmitters

- Pressure
- Temperature
- Level
- Interface Modules

Valves, Actuators and Positioners

- Control Valves
- Actuators
- Positioners

Water, Gas & Industrial Analytics Instrumentation

- pH, Conductivity and Dissolved Oxygen Transmitters and Sensors
- Ammonia, Nitrate, Phosphate, Silica, Sodium, Chloride, Fluoride, Dissolved Oxygen and Hydrazine Analyzers
- Zirconia Oxygen Analyzers, Katharometers, Hydrogen Purity and Purge-gas Monitors, Thermal Conductivity

Customer support

We provide a comprehensive after sales service via a Worldwide Service Organization. Contact one of the following offices for details on your nearest Service and Repair Centre.

UK

ABB Limited
Tel: +44 (0)1453 826661
Fax: +44 (0)1453 829671

USA

ABB Inc.
Tel: +1 215 674 6000
Fax: +1 215 674 7183

Client Warranty

Prior to installation, the equipment referred to in this manual must be stored in a clean, dry environment, in accordance with the Company's published specification.

Periodic checks must be made on the equipment's condition. In the event of a failure under warranty, the following documentation must be provided as substantiation:

- A listing evidencing process operation and alarm logs at time of failure.
- Copies of all storage, installation, operating and maintenance records relating to the alleged faulty unit.

ABB Limited

Process Automation

Oldends Lane
Stonehouse
Gloucestershire GL10 3TA
UK

Tel: +44 1453 826 661

Fax: +44 1453 829 671

ABB Inc.

Process Automation

125 E. County Line Road
Warminster
PA 18974
USA

Tel: +1 215 674 6000

Fax: +1 215 674 7183

www.abb.com

Note

We reserve the right to make technical changes or modify the contents of this document without prior notice. With regard to purchase orders, the agreed particulars shall prevail. ABB does not accept any responsibility whatsoever for potential errors or possible lack of information in this document.

We reserve all rights in this document and in the subject matter and illustrations contained therein. Any reproduction, disclosure to third parties or utilization of its contents – in whole or in parts – is forbidden without prior written consent of ABB.

Copyright© 2010 ABB

All rights reserved

PROFIBUS is a registered trademark of PROFIBUS organization

IM/MPBS-EN 11.2010