

C50 1/16-DIN PROCESS CONTROLLER CONCISE PRODUCT MANUAL – IM/C50



CAUTION: Installation and configuration should be performed only by personnel who are technically competent to do so. Local Regulations regarding electrical installation & safety must be observed.

1. INSTALLATION

Panel-Mounting

The mounting panel must be rigid and may be up to 6.0mm (0.25 inches) thick. The cut-out required for the instrument is shown on the right. Instruments may be mounted side-by-side in a multiple installation for which the cut-out width (for *n* instruments) is (48*n*-4)mm or (1.89*n*-0.16)inches.

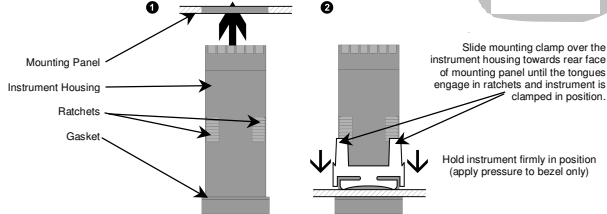

CAUTION: Do not remove the panel gasket; it is a seal against dust and moisture.

Rear Terminal Wiring

USE COPPER CONDUCTORS (EXCEPT FOR T/C INPUT)
Single Strand wire gauge:
Max 1.2mm (18SWG)

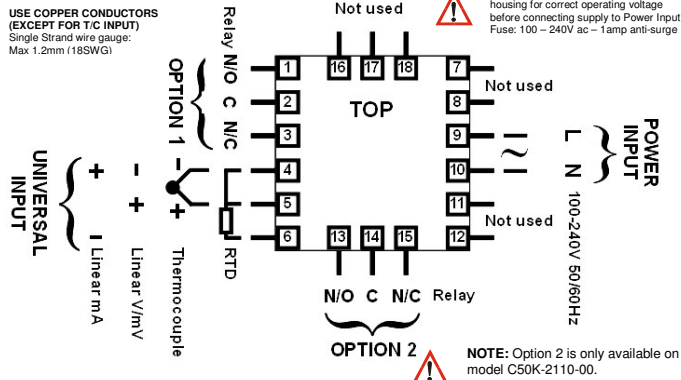

CAUTION: Turn off all power. Remove instrument by gripping the sides of the front panel and pulling the instrument out of its housing. **Note its orientation.**

Note: At first power-up the message `Go to Conf` is displayed, as described in section 8 of this manual. Access to other menus is denied until configuration mode is completed

2. SELECT MODE

Select mode is used to access the configuration and operation menu functions. It can be accessed at any time by holding down **ESC** and pressing **DEL**. Once in select mode, press **DEL** or **DOWN** to select the required mode. An unlock code is required to prevent unauthorised entry to Configuration, Setup & Automatic Tuning modes. Press **DEL** or **DOWN** to enter the correct code number, then press **ESC** to proceed.

Mode	Upper Display	Lower Display	Description	Default Unlock Codes
Operator	OPtr	SLct	Normal instrument operation.	None
Set Up	SEtP	SLct	Tailor settings to the application.	10
Configuration	ConF	SLct	Configures the instrument for use.	20
Product Info	inFo	SLct	Check manufacturing information.	None
Auto-Tuning	Autun	SLct	Invoke Pre-Tune or Self-Tune.	0

Note: The instrument will always return automatically to Operator mode if there is no key activity for 2 minutes.

3. CONFIGURATION MODE

First select Configuration mode from Select mode (refer to section 2). Press **DOWN** to scroll through the parameters, then press **DEL** or **DOWN** to set the required value. To accept a change **ENTER** must be pressed, otherwise parameter will revert to previous value. To exit from Configuration mode, hold down **ESC** and press **DEL**, to return to Select mode.

Note: Parameters displayed depends on how instrument has been configured. Parameters marked * are repeated in Setup Mode.

Parameter	Lower Display	Upper Display	Adjustment range	Default
Input Range/Type	inPt		See following table for possible codes	J T/C
Scale Range Upper Limit	rUL		Scale Range Lower Limit +100 to Range Max	Range max (Lin=1000)
Scale Range Lower Limit	rLL		Range Min. to Scale Range Upper Limit -100	Range min (Linear=0)
Decimal point position	dPoS		0=XXXX, 1=XXX.X, 2=XX.XX, 3=X.XXX (non-temperature ranges only)	1
Control Type	CtYP	SnGL	Primary (heat) only	SnGL
		duAL	Primary & Secondary (heat/cool)	
Primary Output Control Action	CtLr	rEu	Reverse Acting	rEu
		dIr	Direct Acting	
Alarm 1 Type	ALR1	P_Hi	Process High Alarm	P_Hi
		P_Lo	Process Low Alarm	
		dE	Deviation Alarm	
		bAnD	Band Alarm	
		nonE	No alarm	
High Alm 1 value*	PhR1		Range Min. to Range Max in display units	Range Max.
Low Alm 1 value*	PLR1			Range Min.
Band Alm 1 value*	bAL1		1 LSD to span from setpoint in display units	5
Dev. Alm 1 value*	dAL1		+/- Span from setpoint in display units	5
Alm 1 Hysteresis*	AHY1		1 LSD to full span in display units	1
Alarm 2 Type	ALR2	P_Hi	Process High Alarm	P_Lo
		P_Lo	Process Low Alarm	
		dE	Deviation Alarm	
		bAnD	Band Alarm	
		nonE	No alarm	
High Alm 2 value*	PhR2		Range Min. to Range Max in display units	Range Max.
Low Alm 2 value*	PLR2			Range Min.
Band Alm 2 value*	bAL2		1 LSD to span from setpoint in display units	5
Dev. Alm 2 Value*	dAL2		+/- Span from setpoint in display units	5
Alm 2 Hysteresis*	AHY2		1 LSD to full span in display units	1
Loop Alarm	LAEn	d,SA	(disabled) or EnAb (enabled)	d,SA
Loop Alarm Time*	LARt		1 sec to 99 mins. 59secs (only applies if primary proportional band = 0)	99.59
Alarm Inhibit	Inh	nonE	No alarms Inhibited	nonE
		ALR1	Alarm 1 inhibited	
		ALR2	Alarm 2 inhibited	
		both	Alarm 1 and alarm 2 inhibited	

Parameter	Lower Display	Upper Display	Adjustment range	Default
Output 1 Usage	USE1	Pri	Primary (Heat) Power	Pri
		Sec	Secondary (Cool) Power	
		ALd	Alarm 1, Direct	
		ALr	Alarm 1, Reverse	
		ARd	Alarm 2, Direct	
		ARr	Alarm 2, Reverse	
		LPd	Loop Alarm, Direct	
		LPr	Loop Alarm, Reverse	
		ORd	Logical Alarm 1 OR 2, Direct	
		ORr	Logical Alarm 1 OR 2, Reverse	
Output 2 Usage	USE2	Pri	Primary (Heat) Power	ALd
		Sec	Secondary (Cool) Power	
		ALd	Alarm 1, Direct	
		ALr	Alarm 1, Reverse	
		ARd	Alarm 2, Direct	
		ARr	Alarm 2, Reverse	
		LPd	Loop Alarm, Direct	
		LPr	Loop Alarm, Reverse	
		ORd	Logical Alarm 1 OR 2, Direct	
		ORr	Logical Alarm 1 OR 2, Reverse	
		Ad_d	Logical Alarm 1 AND 2, Direct	
		Ad_r	Logical Alarm 1 AND 2, Reverse	
Display Strategy	d,SP		1, 2, 3, 4, 5 or 6 (refer to section 7)	1
Config Lock Code	CLoc		0 to 9999	20

Input Ranges and Types

(See Configuration Mode Parameter inPt)







Code	Input Type & Range	Code	Input Type & Range	Code	Input Type & Range
bC	B: 100 – 1824 °C	LC	L: 0.0 – 537.7 °C	P24F	PIRh20% vs 40%: 32 – 3362 °F
bF	B: 211 – 3315 °F	LF	L: 32.0 – 999.9 °F	PtF	PT100: -199 – 800 °C
cC	C: 0 – 2320 °C	NC	N: 0 – 1399 °C	PtF	PT100: -328 – 1472 °F
cF	C: 32 – 4208 °F	NF	N: 32 – 2551 °F	PtF	PT100: -128.8 – 537.7 °C
jC	J: -200 – 1200 °C	rC	R: 0 – 1759 °C	PtF	PT100: -199.9 – 999.9 °F
jF	J: -328 – 2192 °F	rF	R: 32 – 3198 °F	PtF	PT100: -199.9 – 999.9 °F
J.C	J: -128.8 – 537.7 °C	SC	S: 0 – 1762 °C	0.20	0 – 20 mA DC
J.F	J: -199.9 – 999.9 °F	SF	S: 32 – 3204 °F	4.20	4 – 20 mA DC
K.C	K: -240 – 1373 °C	tC	T: -240 – 400 °C	0.50	0 – 50 mV DC
K.F	K: -400 – 2503 °F	tF	T: -400 – 752 °F	10.50	10 – 50 mV DC
H.C	K: -128.8 – 537.7 °C	tC	T: -128.8 – 400.0 °C	0.5	0 – 5 V DC
H.F	K: -199.9 – 999.9 °F	tF	T: -199.9 – 752.0 °F	1.5	1 – 5 V DC
LC	L: 0 – 762 °C		PIRh20% vs 40%: 0 – 1850 °C	0.10	0 – 10 V DC
LF	L: 32 – 1403 °F	P24C		2.10	2 – 10 V DC

ABB Ltd.
Howard Road, St. Neots
Cambridgeshire, PE19 8EU
UK
Tel +44 (0)1480 475321
Fax +44 (0)1480 217948



4. SETUP MODE

Note: Configuration must be completed before adjusting Setup parameters.





First select Setup mode from Select mode (refer to section 2). While in Setup Mode  is lit. Press  to scroll through the parameters, then press  or  to set the required value. To exit from Setup mode, hold down  and press , to return to Select mode.

Note: Parameters displayed depends on how instrument has been configured.

Parameter	Lower Display	Upper Display Adjustment Range	Default
Input Filter Time constant	F _{ILT}	OFF or 0.5 to 100.0 secs	2.0
Process Variable Offset	OFFS	+/- Span of controller	0
Primary (Heat) power	PPLWJ	Current power levels (read only)	N/A
Secondary (Cool) power	SPLWJ		
Primary Proportional Band	Pb ₁ P	0.0% (ON/OFF) and 0.5% to 999.9% of input span.	10.0
Secondary Proportional Band	Pb ₂ S		
Automatic Reset (Integral Time)	ARSt	1 sec to 99 mins 59 secs and OFF	5.00
Rate (Derivative Time)	rRtE	00 secs to 99 mins 59 secs	1.15
Overlap/Deadband	OL	-20 to +20% of Primary and Secondary Proportional Band	0
Manual Reset (Bias)	b ₁ AS	0%(-100% if dual control) to 100%	25
Primary ON/OFF Differential	d ₁ FP	0.1% to 10.0% of input span centered about the setpoint	0.5
Secondary ON/OFF Diff.	d ₂ FP		
Prim. & Sec. ON/OFF Diff.	d ₁ FF		
Setpoint Upper Limit	SPuL	Current Setpoint to Range max	R/max
Setpoint Lower limit	SPlL	Range min to Current Setpoint	R/min
Primary Output Power Limit	OPuL	0% to 100% of full power.	100
Output 1 Cycle Time	Ct ₁	0.5, 1, 2, 4, 8, 16, 32, 64, 128, 256 or 512 seconds	32
Output 2 Cycle Time	Ct ₂		
High Alarm 1 value	PhR ₁	Range Min. to Range Max.	R/max
Low Alarm 1 value	PLA ₁		R/min
Deviation Alarm 1 Value	dAL ₁	+/- Span from SP in display units	5
Band Alarm 1 value	bAL ₁	1 LSD to span from setpoint	5
Alarm 1 Hysteresis	AHY ₁	1 LSD to full span in display units	1
High Alarm 2 value	PhR ₂	Range Min. to Range Max.	R/max
Low Alarm 2 value	PLA ₂		R/min
Deviation Alarm 2 Value	dAL ₂	+/- Span from SP in display units	5
Band Alarm 2 value	bAL ₂	1 LSD to span from setpoint	5
Alarm 2 Hysteresis	AHY ₂	1 LSD to full span in display units	1
Loop Alarm Time	LAt	1 sec to 99 mins. 59secs.	99.59
Auto Pre-tune	APt	d ₁ SA disabled or EnAb enabled	d ₁ SA
Auto/manual Control selection	PoEn		
Setpoint ramping	SPr	1 to 9999 units/hour or Off (blank)	Off
SP Ramp Rate Value	rP		
Setpoint Value	SP	Scale range upper to lower limits	Scale Range min
Setup Lock Code	SLoc	0 to 9999	10

5. AUTOMATIC TUNING MODE

First select Automatic tuning mode from Select mode (refer to section 2).

Press  to scroll through the modes, then press  or  to set the required value. To exit from Automatic tuning mode, hold down  and press , to return to Select mode. Pre-tune is a single-shot routine and is thus self-disengaging when complete.



If APt in Setup mode = EnAb, Pre-tune will attempt to run at every power up*.

Parameter	Lower Display	Upper Display Adjustment Range	Default
Pre-Tune	Ptun	On or OFF. Indication remains OFF if automatic tuning cannot be used at this time*.	OFF
Self-Tune	Stun		
Tune Lock	tLoc	0 to 9999	0

* Note: Automatic tuning will not engage if either proportional band = 0. Also, Pre-tune will not engage if setpoint is ramping, or the PV is within 5% of span of the setpoint.

8. ERROR/FAULT INDICATIONS

First select Product information mode from Select mode (refer to section 2).



Press  to view each parameter. To exit from Product Information mode, hold down  and press  to return to Select mode. Note: These parameters are all read only.

Parameter	Lower Display	Upper Display	Description
Input type	In ₁	Un ₁	Universal input only
Option 1 module type fitted	OPn ₁	nonE	No option fitted.
		rLY	Relay
Option 2 module type fitted	OPn ₂	nonE	No option fitted.
		rLY	Relay
Option 3	OPn ₃	nonE	Option 3 not available on this product
Option A	OPnA	nonE	Option A not available on this product
Firmware type	FLW		Value displayed is firmware type number
Firmware issue	ISS		Value displayed is firmware issue number
Product Revision Level	PrL		Value displayed is Product Revision level.
Date of manufacture	d0000		Manufacturing date code (mmyy)
Serial number 1	S _{n1}		First four digits of serial number
Serial number 2	S _{n2}		Middle four digits of serial number
Serial number 3	S _{n3}		Last four digits of serial number



7. OPERATOR MODE

This mode is entered at power on. It can also be accessed from Select mode (see section 2).



Note: All configuration mode and Setup mode parameters must be set as required before starting normal operations.



Press  to scroll through the parameters, then press  or  to set the required value.





Note: All parameters in Display strategy 6 are read only, and can only be adjusted via Setup mode.

Upper Display	Lower Display	Display Strategy When Visible	Description
PV Value	Active SP Value	1 & 2 (initial screen)	PV and target value of selected SP SP adjustable in Strategy 2
PV Value	Actual SP Value	3 & 6 (initial screen)	PV and actual value of selected SP (e.g. ramping SP value). Read only
PV Value	(Blank)	4 (initial screen)	Process variable only. Read only
Active SP Value	(Blank)	5 (initial screen)	Target value of selected setpoint only. Read only
SP Value	SP	1, 3, 4, 5 & 6	Target value of SP Adjustable except in Strategy 6
Actual SP Value	SPrP	SPr enabled and rP is not zero	Actual (ramping) value of selected SP Read only
Ramp Rate	rP	SPr enabled in Setup mode	SP ramping rate, in units per hour. Adjustable except in Strategy 6
Active Alarms	ALSt	When one or more alarms are active. ALM indicator will also flash	 Alarm 2 active  Alarm 1 active  Loop Alarm active

Manual Control

If PoEn is set to EnAb in Setup mode, manual control can be selected/de-selected by pressing the  key while in Operator mode. The  indicator will flash while in the instrument is in Manual Control mode and the lower display will show Pxxx (where xxx is the current manual power level). Switching to/from manual mode is via Bumpless Transfer.

Press  or  to set the required output power. **Caution: Not restricted by OPuL limit.**

Parameter	Upper Display	Lower Display	Description
Instrument parameters are in default conditions	GoTo	Conf	Configuration & Setup required. Seen at first turn on or if hardware configuration changed. Press  to enter the Configuration Mode, next press  or  to enter the unlock code number, then press  to proceed.
Over Range	rHH ₂	Normal	Input > 5% over-range
Under Range	rLL ₂	Normal	Input > 5% under-range
Sensor Break	OPEN	Normal	Break in input sensor or wiring
Option 1 Error	Err	OPn ₁	Option 1 module fault
Option 2 Error		OPn ₂	Option 2 module fault

10. SPECIFICATIONS

UNIVERSAL INPUT

Impedance: >10MΩ resistive, except DC mA (5Ω) and V (47kΩ).
Isolation: Isolated from relay outputs and power supply at 240VAC.

OUTPUTS

Relay
Contact Type/Rating: Single pole double throw (SPDT); 2A resistive at 120/240VAC.
Lifetime: >500,000 operations at rated voltage/current.
Isolation: Isolated from input, other relay outputs and power supply at 240VAC.

OPERATING CONDITIONS FOR INDOOR USE

Ambient Temperature: 0 °C to 55 °C (Operating)
Ambient Temperature: -20 °C to 80 °C (Storage)
Relative Humidity: 20% - 95% non-condensing
Supply Voltage: 100 - 240VAC 50/60Hz 7.5VA for mains powered versions.

ENVIRONMENTAL

Standards: CE, UL, ULC
EMI: Complies with EN61326 (Susceptibility & Emissions)
Safety Considerations: Complies with EN61010-1 & UL3121
Pollution Degree 2, Installation Category II
Front Panel Sealing: To IP66

PHYSICAL

Dimensions Depth: 110mm (behind panel)
Front panel height: 48mm
Front panel width: 48mm
Weight: 0.21kg maximum

ABB Ltd.

Howard Road, St. Neots
Cambridgeshire, PE19 8EU
UK
Tel +44 (0)1480 475321
Fax +44 (0)1480 217948

