











# Electrical Safety

This equipment complies with the requirements of CEI/IEC 61010-1:2001-2 "Safety requirements for electrical equipment for measurement, control, and laboratory use". If the equipment is used in a manner NOT specified by the Company, the protection provided by the equipment may be impaired.

## Symbols

One or more of the following symbols may appear on the equipment labelling:

	<b>Warning</b> – Refer to the manual for instructions
	<b>Caution</b> – Risk of electric shock
	Protective earth (ground) terminal
	Earth (ground) terminal

	Direct current supply only
	Alternating current supply only
	Both direct and alternating current supply
	The equipment is protected through double insulation

Information in this manual is intended only to assist our customers in the efficient operation of our equipment. Use of this manual for any other purpose is specifically prohibited and its contents are not to be reproduced in full or part without prior approval of the Technical Publications Department.

### Health and Safety

To ensure that our products are safe and without risk to health, the following points must be noted:

1. The relevant sections of these instructions must be read carefully before proceeding.
2. Warning labels on containers and packages must be observed.
3. Installation, operation, maintenance and servicing must only be carried out by suitably trained personnel and in accordance with the information given.
4. Normal safety precautions must be taken to avoid the possibility of an accident occurring when operating in conditions of high pressure and/or temperature.
5. Chemicals must be stored away from heat, protected from temperature extremes and powders kept dry. Normal safe handling procedures must be used.
6. When disposing of chemicals ensure that no two chemicals are mixed.

Safety advice concerning the use of the equipment described in this manual or any relevant hazard data sheets (where applicable) may be obtained from the Company address on the back cover, together with servicing and spares information.

---

# CONTENTS

---

<b>1</b>	<b>INTRODUCTION .....</b>	<b>2</b>
<b>2</b>	<b>ELECTRICAL INSTALLATION .....</b>	<b>2</b>
	2.1 Host Computer Serial Communications .....	2
	2.2 Two-wire and Four-wire Connection .....	2
	2.3 Pull-up and Pull-down Resistors .....	5
	2.4 Termination Resistor .....	5
	2.5 Serial Connections .....	5
<b>3</b>	<b>CONFIGURATION .....</b>	<b>6</b>
	3.1 Accessing the Configuration Mode .....	6
	3.2 Setting the Serial Transmission Parameters .....	6
	3.3 Setting the MODBUS Address .....	6
<b>4</b>	<b>MODBUS PROTOCOL .....</b>	<b>7</b>
	4.1 Introduction .....	7
	4.2 MODBUS Function Codes .....	8
<b>5</b>	<b>MODBUS FUNCTIONS .....</b>	<b>9</b>
	5.1 Read Coil Status – Function Code 01 .....	9
	5.2 Read Holding Register – Function Code 03 .....	10
	5.3 Force Single Coil – Function Code 05 .....	11
	5.4 Preset Single Register – Function Code 06 .....	12
	5.5 Loopback Test – Function Code 08 .....	13
	5.6 Write Multiple Registers – Function Code 16 .....	14
<b>6</b>	<b>EXCEPTION RESPONSES .....</b>	<b>15</b>
	6.1 Examples .....	15
<b>7</b>	<b>ADDRESSABLE PARAMETERS .....</b>	<b>16</b>
	7.1 COMMANDER 100/V100 – Coils .....	16
	7.2 COMMANDER 100/V100 – Registers .....	16
	7.2.1 Analog Inputs .....	16
	7.2.2 Control Settings .....	17
	7.2.3 Set Points .....	18
	7.2.4 Alarm Settings .....	18
	7.2.5 Ramp/Soak Settings .....	18
	7.3 COMMANDER 150 / 160 – Coils .....	19
	7.4 COMMANDER 150 / 160 – Registers .....	19
	7.4.1 Analog Inputs .....	19
	7.4.2 Alarm Settings .....	19
	7.4.3 Totalizer Settings .....	20
	7.4.4 Maths Functions .....	20

---

# 1 INTRODUCTION

---

This Operating Guide describes the COMMANDER 100, 150, 160 and V100 MODBUS serial data communications option and must be used in conjunction with the standard *User Guide* (part no. IM/C100, IM/C150, IM/C160 or IM/V100) supplied with the instrument.

## **Information.**

The MODBUS option provides the following facilities:

- Standard RS422/485 communications.
- MODBUS RTU protocol – for master (host computer) to slave (COMMANDER 100/150/160/V100) system.
- 500V d.c isolation from external connections to the instrument.
- Two-wire or four-wire communication.
- 2400 or 9600 baud transmission rate.
- Parity-checking – odd, even or none.

---

# 2 ELECTRICAL INSTALLATION

---

This section describes the connection of serial data transmission cables between the master (host computer) and slave instruments on a MODBUS serial link. All connections other than those used for serial communication are shown in Section 5 of the relevant *User Guide*.

## **2.1 Host Computer Serial Communications**

An RS422/485 communications driver must be fitted to the host computer. It is strongly recommended that the interface has galvanic isolation to protect the computer from lightning damage and increase signal immunity to noise pick-up.

## **2.2 Two-wire and Four-wire Connection – Figs. 2.1 and 2.2**

MODBUS serial communications must be configured as either two-wire or four-wire serial links – see Figs. 2.1 and 2.2. Two-/four-wire operation must also be selected in the Configuration Mode – see Section 3.1.

## ...2.2 Two-wire and Four-wire Connection

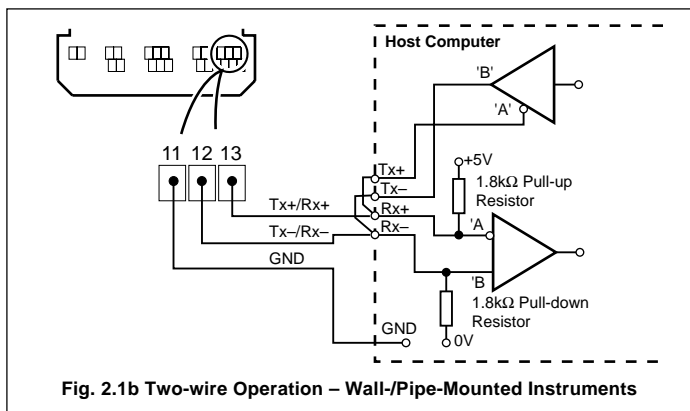
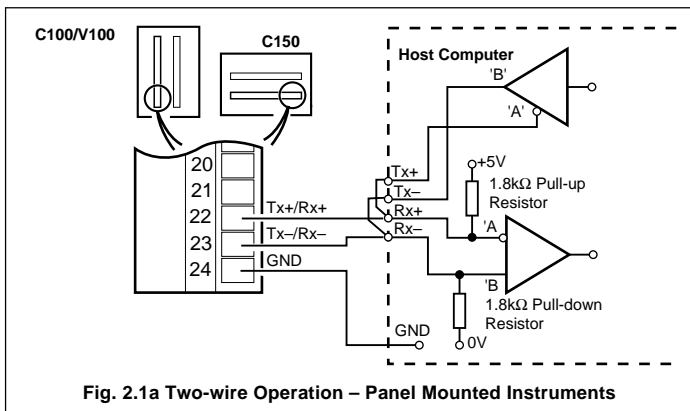

## ...2 ELECTRICAL INSTALLATION

### ...2.2 Two-wire and Four-wire Connection

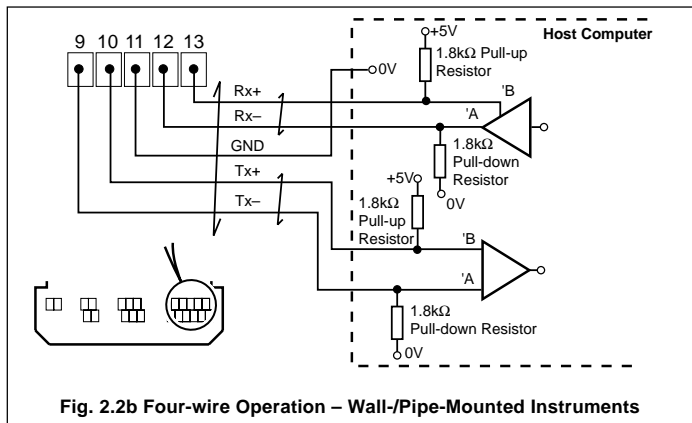
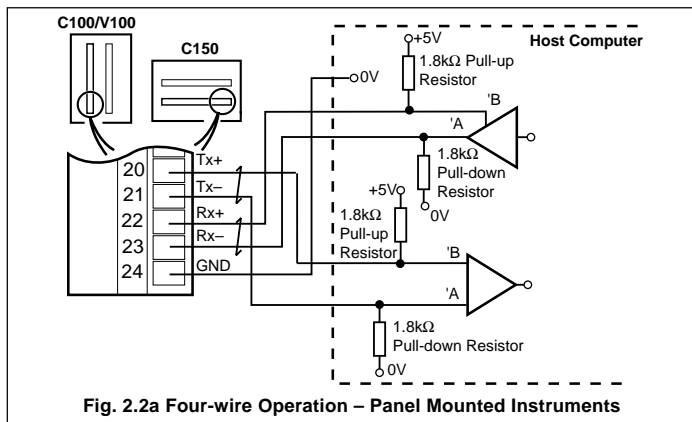

### 2.3 Pull-up and Pull-down Resistors – Fig. 2.1 and 2.2

To prevent false triggering of slaves when the master (host computer) is inactive, pull-up and pull-down resistors must be fitted to the RS422/485 interface in the host computer – see Figs. 2.1 and 2.2.

**Note.** Resistors are normally connected to the interface by means of hard-wired links or switches – refer to the manufacturer's instructions.

### 2.4 Termination Resistor – Fig. 2.3

For long transmission lines, a  $120\Omega$  termination resistor must be fitted to the last slave in the chain – see Fig. 2.3.

### 2.5 Serial Connections – Figs. 2.1 to 2.3

#### Information.

- Up to **10 slaves** can be connected to a single **RS422** adaptor card on a PC.
  - Up to **32 slaves** can be connected to a single **RS485** adaptor card on a PC.
- The number of slaves can be increased if the driver's serial port permits.

Connections to the MODBUS serial board must be made as shown in Figs. 2.1 to 2.3. Connections on links with multiple slaves must be made in parallel, as shown in Fig. 2.3. When connecting cable screens, ensure that no 'ground loops' are introduced.

The maximum serial data transmission line length for both **RS422** and **RS485** systems is 1200m. The types of cable that can be used are determined by the total line length:

- Up to 6m** – standard screened or twisted pair cable.
- Up to 300m** – twin twisted pair with overall foil screen and an integral drain wire.
- Up to 1200m** – twin twisted pair with separate foil screens and integral drain wires.

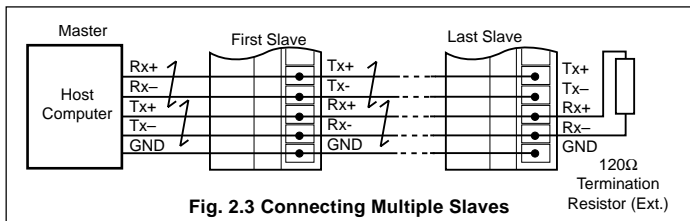

**Fig. 2.3 Connecting Multiple Slaves**

## 3 CONFIGURATION

### Information.

- Programmable baud rate – 2400 or 9600 baud.
- Selectable parity – odd, even or none.
- Address range – 1 to 99.

For MODBUS communications to operate correctly, each slave instrument must be configured with the correct serial transmission parameters and assigned a unique address.

### 3.1 Accessing the Configuration Mode

To access the Configuration Mode, set the security switch to the 'Configure' position, as shown in Fig. 4.1 of the relevant *User Guide*. When all parameters have been programmed, reset the switch to the 'Normal' position.

### 3.2 Setting the Serial Transmission Parameters – Fig. 3.1

Fig. 3.1 shows the display readouts and options available when defining the serial transmission rate and bit parity for COMMANDER 100, 150, 160 and V100 instruments. Further detail on the procedure required to set each parameter are shown in Section 4.3.4 of the relevant *User Guide*.

### 3.3 Setting the MODBUS Address

To allow the master to differentiate between more than one slave in a system, each slave on a MODBUS link must be assigned a unique address in the range 1 to 99. See Section 4.4 of the relevant *User Guide* (MODBUS Address Frame, *Addr*).

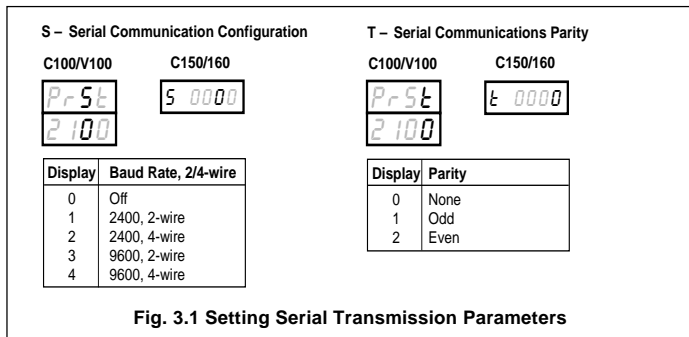

---

## 4 MODBUS PROTOCOL

---

### Information.

- The COMMANDER 100, 150, 160 and V100 operate as MODBUS, Remote Terminal Unit (RTU) slaves.
- Parity checking – detects transmission errors in individual characters.
- Cyclic redundancy checking – detects errors in the master messages and slave responses.
- Negative numbers are represented in two's compliment format.  
e.g           1000 = 0x03E8  
      -1000 = 0xFC18

### 4.1 Introduction

MODBUS communication uses the master/slave principle to send messages to one or more slaves. Each slave is given a unique identity address (between 1 and 99).

A broadcast address (address zero) can be used to write to all slave devices simultaneously, using one command. In this instance there is no slave acknowledgment.

Slaves cannot accept new messages until the current message has been processed and a reply sent to the master (maximum response time 250ms). The slave monitors the elapsed time between receipt of characters. If the elapsed time without a new character is  $3\frac{1}{2}$  character times, the slave assumes the next character received is the start of a new message.

**Note.** MODBUS RTU requires 1 start bit, 8 data bits, 1 parity bit (optional) and 1 or 2 stop bits.

**4.2 MODBUS Function Codes**

The function code instructs the addressed slave which function to perform. Table 4.1 shows the function codes, and describes the action they initiate.

<b>Function Code</b>	<b>Function Title</b>	<b>Description</b>
01	Read Coil Status	Read up to 16 consecutive discrete (Boolean) points from a specific starting point. The slave instrument returns zeros for points which do not contain defined data and NAKs* any request for point numbers greater than 60.
03	Read Holding Register	Read up to 8 consecutive registers from a specific starting register. The slave instrument returns zeros for points which do not contain defined data and NAKs* any request for point numbers greater than 90.
05	Force Single Coil	Write one discrete (Boolean) point. The slave instrument NAKs* this if the point is not currently writeable.
06	Preset Single Register	Write one register. This code also applies any existing limits to the register before storage in the instrument. The slave instrument NAKs* if the register is not currently writeable.
08	Loop Back	Echo the message. Only 'Return of Query' is supported.
16	Preset Multiple Registers	Write up to eight consecutive registers from a specified starting register. The slave instrument NAKs* if any of the registers are not currently writeable, but carries out all the writes which are valid, applying any existing limits to the value before storage in the instrument.

\*NAK = Negative Acknowledgment

**Table 4.1 MODBUS Function Codes**

## 5 MODBUS FUNCTIONS

This section shows typical examples of MODBUS function codes 01, 03, 05, 06, 08 and 16. Not all addressable parameters used in the examples which follow are valid for all instrument types – see Sections 7.1 to 7.4.

### 5.1 Read Coil Status – Function Code 01

#### 5.1.1 Read Coil Status Query

This function obtains the ON/OFF status of logic coils used to control discrete outputs from the addressed slave. Broadcast mode is not supported with this function code. In addition to the slave address and function fields, the information field must contain the initial coil offset address (starting address) and the number of each location to be interrogated.

**Note.** The coil offset address is one less than the coil number, e.g. to start at coil 06 the start address must be set to 05 (05H).

**Example.** Read 16 coils from slave (01) starting at coil 6 (alarm state 1).

Address	Function	Coil Start Offset High	Coil Start Offset Low	No. of Coils High	No. of Coils Low	Error Check Field	(CRC-16)
01	01	00	05	00	10	2D	C7

#### 5.1.2 Read Coil Status Response

The data is packed one bit for each coil (1 = ON, 0 = OFF). The response includes the slave address, function code, quantity of data characters, the data characters and error checking. The low order bit of the first character contains the first addressed coil and the remainder follow. For coil quantities that are not multiples of eight, the last characters are packed with zeros at the high order end.

#### Example

Alarms 1, 2 and 3 inactive

Digital input inactive

Digital output inactive

Relays 1 and 2 active

ON/OFF status 1 and 2 active

Address	Function	Byte Count	Data Coil Status 6 to 13	Data Coil Status 14 to 21	Error Check Field	(CRC-16)
01	01	02	00	3E	38	2C

## ...5 MODBUS FUNCTIONS

### 5.2 Read Holding Register – Function Code 03

#### 5.2.1 Read Holding Register Query

The Read Holding Register Query obtains the contents of up to eight holding registers in the addressed slave.

**Note.** The data start register must contain the offset address of the first register to be accessed, e.g. to start at register 1 the data start register must contain 00 (00H).

Broadcast mode is not supported by Function Code 03.

**Example.** Read three holding registers from slave (01) starting at holding address 01 (process variable input).

Address	Function	Register Start Offset High	Register Start Offset Low	Data No. of Registers High	Data No. of Registers Coils Low	Error Check Field	(CRC-16)
01	03	00	00	00	03	05	CB

#### 5.2.2 Read Holding Register Response

The addressed slave responds with its address and function code, followed by the information field. The information field contains one byte describing the quantity of data bytes to be returned. Two bytes are used to return each register requested, the first byte containing the high order bits and the second the low order bits.

##### Example

PV input (two registers) – 270

PV decimal places – 1

Address	Function	Byte Count	Holding Register 01 High Low	Holding Register 02 High Low	Holding Register 03 High Low	Error Check Field	(CRC-16)
01	03	00	00 00	01 09	00 01	49	75

### 5.3 Force Single Coil – Function Code 05

#### 5.3.1 Force Single Coil Query

This message forces a single coil either ON or OFF. The data value 65,280 (FF00 HEX) sets the coil ON and the value zero turns it OFF. All other values are illegal and have no effect on coil status.

**Note.** To write to a coil its offset address (one less than the coil number) must be used, e.g. to write to coil 30, the coil address 29 (1CH) is transmitted.

The use of slave address zero (broadcast mode) forces all attached slaves to modify the desired coil.

**Example.** Switch ON coil address 30 (auto/manual state) in slave 01.

Address	Function	Coil Offset High	Coil Offset Low	Data Value High	Data Value Low	Error Check Field	(CRC-16)
01	05	00	1D	FF	00	80	FF

#### 5.3.2 Force Single Coil Response

The response is confirmation of the query after the coil state has been altered.

**Example**

Address	Function	Coil Offset High	Coil Offset Low	Data Value High	Data Value Low	Error Check Field	(CRC-16)
01	05	00	1D	FF	00	28	60

## ...5 MODBUS FUNCTIONS

### 5.4 Preset Single Register – Function Code 06

#### 5.4.1 Preset Single Register Query

The Preset Single Register Query modifies the contents of a holding register.

**Note.** Function codes 05, 06 and 16 are the only messages that are recognized as valid for broadcast.

**Example.** Write the value 500 to holding register address 25 (proportional band 1 – heat) in slave 01.

**Note.** To write to a register, its offset address (one less than the register number) must be used, e.g. to write to register 25, the offset address 24 (18H) is transmitted.

Address	Function	Register Offset High	Register Offset Low	Data Value High	Data Value Low	Error Check Field	(CRC-16)
01	06	00	18	01	F4	09	DA

#### 5.4.2 Preset Single Register Response

The response to a Preset Single Register Response requests is to retransmit the query message after the register has been altered.

#### Example

Address	Function	Register Offset High	Register Offset Low	Data Value High	Data Value Low	Error Check Field	(CRC-16)
01	06	00	18	01	F4	09	DA

## 5.5 Loopback Test – Function Code 08

### 5.5.1 Loopback Test Query

The Loopback Test Query tests the MODBUS system and does not affect the operation of the slave. Variations in the response may indicate faults in the MODBUS system. The information field contains two bytes for the designation of the diagnostic code followed by two bytes to designate the action to be taken.

#### Example

Address	Function	Data Diagnostic Code High	Data Diagnostic Code Low	Data*	Data*	Error Check Field	(CRC-16)
01	08	00	00	A5	37	DA	8D

\*These are considered to be the information fields for the diagnostic mode.

### 5.5.2 Loopback Test Response

The Loopback Test Response always echoes the query, only diagnostic code 0 (bytes 3 and 4) can be used.

#### Example

Address	Function	Data Diagnostic Code High	Data Diagnostic Code Low	Data	Data	Error Check Field	(CRC-16)
01	08	00	00	A5	37	DA	8D

## ...5 MODBUS FUNCTIONS

### 5.6 Write Multiple Registers – Function Code 16

#### 5.6.1 Write Multiple Registers Query

This message is used to change the contents of up to eight holding registers at a time. When used with slave address zero (broadcast mode) all slave controllers load the selected registers with the contents specified.

**Note.** To write to a register, its offset address (one less than the register number) must be used, e.g. to write to register 25, the offset address 24 (18H) is transmitted.

**Example.** Write the value 500 to the register address 25 (proportional band 1 – heat) and the value 100 to the register address 26 (integral action time) in slave 01.

Address	Function	Register Start Offset High	Register Start Offset Low	Number of Registers	Byte Count
01	10	00	18	00 02	04

Holding Register 24 High	Holding Register 24 Low	Holding Register 25 High	Holding Register 25 Low	Error Check Field	(CRC16)
01	F4	00	64	B2	E0

#### 5.6.2 Write Multiple Registers Response

The Write Multiple Registers Response confirms slave identification, function code, starting register address and quantity only.

##### Example

Address	Function	Register Start Offset High	Register Start Offset Low	Number of Registers	Error Check Field	(CRC-16)
01	10	00	18	00 02	C1	CF

## 6 EXCEPTION RESPONSES

The exception response codes sent by the slave are shown in Table 6.1. When a slave detects one of these errors, it sends a response message to the master consisting of slave address, function code, error code and error check fields.

Exception Response Code	Exception Response Name	Exception Response Definition
01	Illegal Function	The message function received is not an allowable function on the COMMANDER 100/150/160/V100.
02	Illegal Data Address	The address reference in the data field is not an allowable address for the COMMANDER 100/150/160/V100.
03	Illegal Data Value	The value referenced in the data field is not allowable in the addressed slave location.
07	Negative Acknowledgement	The function just requested cannot be performed.
08	Memory Parity Error	Parity check indicates an error in one or more of the characters received.

**Table 6.1 Exception Response Codes**

### 6.1 Examples

A Read Register Request to read holding register address 100 of Slave 01 (undefined address for Slave, beyond address limit).

Address	Function	Register Start Offset High	Register Start Offset Low	Number of Registers High	Number of Registers Low	Error Check Field	(CRC-16)
01	03	00	FA	00	06	E5	F9

The slave replies with an exception response signifying an 'illegal data address'. To indicate that the response is a notification of an error, the most significant bit of the function code is set to 1.

Slave Address	Function	Exception	Error Check	(CRC-16)
01	83	02	C0	F1

## 7 ADDRESSABLE PARAMETERS

### 7.1 COMMANDER 100/V100 – Coils

Coil No.	Variable Label	Read/Write	Limits/Values
01	Process Variable Fail State	R	1 = Failed
02	Remote Set Point Fail State	R	1 = Failed
03	A/D Converter Fail State	R	1 = Failed
06	Alarm State 1	R	1 = Active
07	Alarm Indicator 1	R	1 = On
08	Alarm State 2	R	1 = Active
09	Alarm Indicator 2	R	1 = On
14	Digital Input State	R	1 = On
15	Digital Output State	R	1 = On
16	Relay 1 State	R	1 = On
17	Relay 2 State	R	1 = On
19	On/Off Output 1 (Heat)	R	1 = On
20	On/Off Output 2 (Cool)	R	1 = On
30	Auto/Manual State	RW	0 = Auto; 1 = Manual
31	Control Action	W	0 = Reverse; 1 = Direct
32	Select Local Set Point	W	1 = Local
33	Select Remote Set Point	W	1 = Remote
34	Select Fixed Set Point 1	W	1 = Selected
35	Select Fixed Set Point 2	W	1 = Selected
36	Select Fixed Set Point 3	W	1 = Selected
37	Select Fixed Set Point 4	W	1 = Selected

### 7.2 COMMANDER 100/V100 – Registers

#### 7.2.1 Analog Inputs

Register	Variable Label	Read/Write	Limits/Values
2	Process Variable Input	R	-999 to 9999
3	PV Decimal Places	R	0 to 4
5	Remote Set Point Input	R	-999 to 9999
6	Remote SP Decimal Places	R	0 to 2

## ...7.2 COMMANDER 100/V100 – Registers

## 7.2.2 Control Settings

Register	Variable Label	Read/Write	Limits/Values
12	Process Variable Input	R	-999 to 9999
13	Control Set Point	R	-999 to 9999
14	Output 1	RW*	-80 to 1100
15	Auto/Manual State	RW	0 = Auto; 1 = Manual
16	Set Point Select	RW	{ <ul style="list-style-type: none"> <li>0 = Local</li> <li>1 = Remote</li> <li>2 = Fixed Set Point 1</li> <li>3 = Fixed Set Point 2</li> <li>4 = Fixed Set Point 3</li> <li>5 = Fixed Set Point 4</li> <li>6 = Ramp/Soak</li> </ul>
17	Output 2	RW*	-80 to 1100
18	Fixed Set Point 1	RW	-999 to 9999
19	Fixed Set Point 2	RW	-999 to 9999
20	Fixed Set Point 3	RW	-999 to 9999
21	Fixed Set Point 4	RW	-999 to 9999
22**	Valve Deadband	RW	1 to 9999
23**	Valve Travel Time	RW	1 to 5000 sec
24**	Valve Drive	RW*	0 = Close 1 = Stop 2 = Open
25	Proportional Band 1	RW	1 to 9999
26	Integral Action Time	RW	0 to 7200
27	Derivative Action Time	RW	0 to 9999
28	Manual Reset	RW	0 to 1000
29	Cycle Time 1	RW	9 to 3000
30	Cycle Time 2	RW	9 to 3000
31	Proportional Band 2	RW	1 to 9999
32	Overlap	RW	100 to -100
33	Control Mode 1 (Heat)	R	{ <ul style="list-style-type: none"> <li>0 = On/Off</li> <li>1 = Analog Control***</li> <li>2 = Time Proportioning</li> </ul>
34	Control Mode 2 (Cool)	R	
35	Control Output 1 Action	RW	0 = Reverse; 1 = Direct
36	Auto/Manual State	RW	0 = Auto; 1 = Manual

\* These registers can only be written to when the controller is in Manual Mode. Control outputs 1 and 2 are only applicable to C100 instruments.

\*\* V100 Instruments only

\*\*\* Control Mode 1 only

## ...7 ADDRESSABLE PARAMETERS

### ...7.2 COMMANDER 100/V100 – Registers

#### 7.2.3 Set Points

Register	Variable Label	Read/Write	Limits/Values
40	Set Point High	RW	-999 to 9999
41	Set Point Low	RW	-999 to 9999
42	Local Set Point	RW	-999 to 9999
44	Remote Set Point Input	R	-999 to 9999
45	Fixed Set Point 1	RW	-999 to 9999
46	Fixed Set Point 2	RW	-999 to 9999
47	Fixed Set Point 3	RW	-999 to 9999
48	Fixed Set Point 4	RW	-999 to 9999

#### 7.2.4 Alarm Settings

Register	Variable Label	Read/Write	Limits/Values
51	Alarm Trip 1	RW	-999 to 9999
53	Alarm Trip 2	RW	-999 to 9999
56	Alarm Hysteresis Value	RW	0 to 100
57	Alarm Type 1	R	0 = None 1 = High Process 2 = Low Process 3 = Not Valid 4 = Not Valid 5 = High Deviation 6 = Low Deviation 7 = Loop Break
58	Alarm Type 2	R	

#### 7.2.5 Ramp/Soak Settings

Register	Variable Label	Read/Write	Limits/Values
65	Ramp/Soak Run	W	1 = Run
66	Ramp/Soak Hold	W	1 = Hold
67	Ramp/Soak Skip	W	1 = Skip
68	Ramp/Soak Stop	W	1 = Stop
69	Program Status	R	0 = Stop 1 = Run 2 = Hold

## 7.3 COMMANDER 150/160 – Coils

Coil No.	Variable Label	Read/Write	Limits/Values
1	Process Variable Fail State	R	1 = Failed
3	A/D Converter Fail State	R	1 = Failed
6	Alarm State 1	R	1 = Active
7	Alarm Indicator 1	R	1 = On
8	Alarm State 2	R	1 = Active
9	Alarm Indicator 2	R	1 = On
10	Alarm State 3	R	1 = Active
11	Alarm Indicator 3	R	1 = On
14	Digital Input State	R	1 = On
15	Digital Output State	R	1 = On
16	Relay 1 State	R	1 = On
17	Relay 2 State	R	1 = On
21	Global Maths Reset	W	1 = Reset
22	Maximum Values Reset	W	1 = Reset
23	Minimum Values Reset	W	1 = Reset
24	Average Values Reset	W	1 = Reset

## 7.4 COMMANDER 150/160 – Registers

## 7.4.1 Analog Inputs

Register	Variable Label	Read/Write	Limits/Values
1 + 2	Process Variable Input	R	-9999 to 99999
3	PV Decimal Places	R	0 to 4

## 7.4.2 Alarm Settings

Register	Variable Label	Read/Write	Limits/Values
50 + 51	Alarm Trip 1	RW	-9999 to 99999
52 + 53	Alarm Trip 2	RW	-9999 to 99999
54 + 55	Alarm Trip 3	RW	-9999 to 99999
56	Alarm Hysteresis Value	RW	0 to 100
57	Alarm Type 1	R	0 = None 1 = High Process 2 = Low Process 3 = High Latch 4 = Low Latch
58	Alarm Type 2	R	
59	Alarm Type 3	R	

---

## ...7.7 ADDRESSABLE PARAMETERS

---

### ...7.4 COMMANDER 150/160 – Registers

#### 7.4.3 Totalizer Settings

Register	Variable Label	Read/Write	Limits/Values
75 + 76	Predetermined Value	R	0 to 999999
77 + 78	Preset Value	R	0 to 999999
79 + 80	Batch Total	R	0 to 999999
81 + 82	Secure Total	R	0 to 999999
83	Total Go State	W	1 = Go
84	Batch Reset	W	1 = Reset

#### 7.4.4 Maths Functions

Register	Variable Label	Read/Write	Limits/Values
85 + 86	Process Variable Maximum	R	-9999 to 99999
87 + 88	Process Variable Minimum	R	-9999 to 99999
89 + 90	Process Variable Average	R	-9999 to 99999

## Customer Support

We provide a comprehensive after sales service via a Worldwide Service Organization. Contact one of the following offices for details on your nearest Service and Repair Centre.

### United Kingdom

ABB Limited

Tel: +44 (0)1480 475321

Fax: +44 (0)1480 217948

### United States of America

ABB Inc.

Tel: +1 215 674 6000

Fax: +1 215 674 7183

#### Client Warranty

Prior to installation, the equipment referred to in this manual must be stored in a clean, dry environment, in accordance with the Company's published specification. Periodic checks must be made on the equipment's condition.

In the event of a failure under warranty, the following documentation must be provided as substantiation:

1. A listing evidencing process operation and alarm logs at time of failure.
2. Copies of all storage, installation, operating and maintenance records relating to the alleged faulty unit.

#### **Acknowledgements**

Modbus is a registered trademark of Modicon

IBM is a trademark of International Business Machines Corp.

---

**ABB** has Sales & Customer Support expertise  
in over 100 countries worldwide

[www.abb.com](http://www.abb.com)

The Company's policy is one of continuous product  
improvement and the right is reserved to modify the  
information contained herein without notice.

Printed in UK (07.05)

© ABB 2005



#### **ABB Limited**

Howard Road, St. Neots  
Cambridgeshire  
PE19 8EU  
UK  
Tel: +44 (0)1480 475321  
Fax: +44 (0)1480 217948

#### **ABB Inc.**

125 E. County Line Road  
Warminster  
PA 18974  
USA  
Tel: +1 215 674 6000  
Fax: +1 215-674 7183