

pH/Redox (ORP) Analyzers

Models 4630 & 4635
(incorporating Water Wash Versions 4631 & 4636)



The Company

We are an established world force in the design and manufacture of instrumentation for industrial process control, flow measurement, gas and liquid analysis and environmental applications.

As a part of ABB, a world leader in process automation technology, we offer customers application expertise, service and support worldwide.

We are committed to teamwork, high quality manufacturing, advanced technology and unrivalled service and support.

The quality, accuracy and performance of the Company's products result from over 100 years experience, combined with a continuous program of innovative design and development to incorporate the latest technology.

The UKAS Calibration Laboratory No. 0255 is just one of the ten flow calibration plants operated by the Company and is indicative of our dedication to quality and accuracy.

EN ISO 9001:2000



Cert. No. Q 05907

EN 29001 (ISO 9001)



Lenno, Italy – Cert. No. 9/90A

Stonehouse, U.K.



0255

Use of Instructions



Warning.

An instruction that draws attention to the risk of injury or death.



Note.

Clarification of an instruction or additional information.



Caution.

An instruction that draws attention to the risk of damage to the product, process or surroundings.



Information.

Further reference for more detailed information or technical details.

Although **Warning** hazards are related to personal injury, and **Caution** hazards are associated with equipment or property damage, it must be understood that operation of damaged equipment could, under certain operational conditions, result in degraded process system performance leading to personal injury or death. Therefore, comply fully with all **Warning** and **Caution** notices.

Information in this manual is intended only to assist our customers in the efficient operation of our equipment. Use of this manual for any other purpose is specifically prohibited and its contents are not to be reproduced in full or part without prior approval of the Marketing Communications Department.

Health and Safety

To ensure that our products are safe and without risk to health, the following points must be noted:

1. The relevant sections of these instructions must be read carefully before proceeding.
2. Warning labels on containers and packages must be observed.
3. Installation, operation, maintenance and servicing must only be carried out by suitably trained personnel and in accordance with the information given.
4. Normal safety precautions must be taken to avoid the possibility of an accident occurring when operating in conditions of high pressure and/or temperature.
5. Chemicals must be stored away from heat, protected from temperature extremes and powders kept dry. Normal safe handling procedures must be used.
6. When disposing of chemicals ensure that no two chemicals are mixed.

Safety advice concerning the use of the equipment described in this manual or any relevant hazard data sheets (where applicable) may be obtained from the Company address on the back cover, together with servicing and spares information.

CONTENTS

Section	Page	Section	Page
1 INTRODUCTION	2	7 PROGRAMMING	22
2 PREPARATION	2	7.1 Access to Secure Parameters	24
2.1 Checking the Code Number	2	7.2 Language Page	24
2.1.1 Wall-/Pipe-mounted Instruments	2	7.3 Set Up Parameters Page	24
2.1.2 Panel-mounted Instruments	2	7.4 Set Up Alarms Page	26
3 MECHANICAL INSTALLATION	3	7.5 Set Up Retransmission Page	28
3.1 Siting Requirements	3	8 CALIBRATION	30
3.2 Mounting	4	8.1 Equipment Required	30
3.2.1 Wall-/Pipe-mounted Instruments	4	8.2 Preparation	30
3.2.2 Panel-mounted Instruments	5	8.3 Factory Settings Page	31
4 ELECTRICAL CONNECTIONS	6	9 SIMPLE FAULT FINDING	33
4.1 Access to Terminals	6	9.1 Error Messages	33
4.1.1 Wall-/Pipe-mounted Instruments	6	9.2 Calibration Fail Message or no Response to pH/Redox Changes	33
4.1.2 Panel-mounted Instruments	6	9.3 Checking the Temperature Input	33
4.2 Connections, General	7	10 SPECIFICATION	34
4.2.1 Relay Contact Protection and Interference Suppression	7		
4.3 Connections – Wall-/Pipe-mounted Instruments	9		
4.4 Connections – Panel-mounted Instruments	10		
4.5 Selecting the Mains Voltage	11		
4.5.1 Wall-/Pipe-mounted Instruments	11		
4.5.2 Panel-mounted Instruments	11		
5 CONTROLS AND DISPLAYS	12		
5.1 Displays	12		
5.2 Controls Familiarization	12		
6 OPERATION	13		
6.1 Instrument Start-up	13		
6.2 Operation – pH Measurement Mode	13		
6.2.1 Operating Page	14		
6.2.2 Single Point pH Calibration	16		
6.2.3 Two-point pH Calibration (Automatic Mode)	17		
6.2.4 Two-point pH Calibration (Manual Mode)	19		
6.3 Operation – Redox (ORP) Measurement Mode	21		
6.3.1 Operating Page	21		

1 INTRODUCTION

The 4630/31 and 4635/36 pH/Redox transmitters and associated electrode systems have been designed for continuous monitoring and control of pH. The electrode system can be standardized to the instrument using the built-in calibration facility and a single point buffering facility provides easy re-calibration after initial standardization.

The 4630/31 models are wall- or pipe-mounted instruments and the 4635/36 models are panel-mounted, DIN sized instruments. All instruments have a single programmable pH input channel, and a single temperature input channel. When making temperature compensated measurements the sample temperature is sensed by a Pt100 resistance thermometer which can be mounted in the electrode system.

Models 4631 and 4636 incorporate a water wash facility for system cleaning. During the wash cycle, the Alarm 1 status and the retransmission value are held in their pre-cycle condition.

Instrument operation and programming is via four tactile membrane keys located on the front panel. Programmed functions are protected from unauthorized alteration by a five-digit security code.

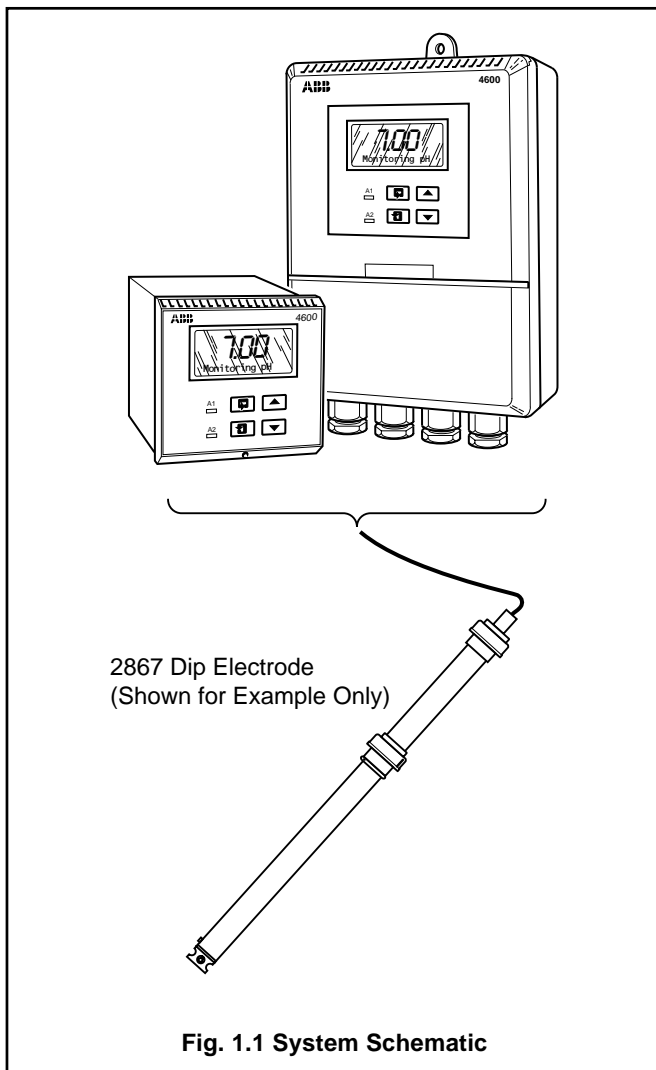

2 PREPARATION

2.1 Checking the Code Number

2.1.1 Wall-/Pipe-mounted Instruments – Fig. 2.1

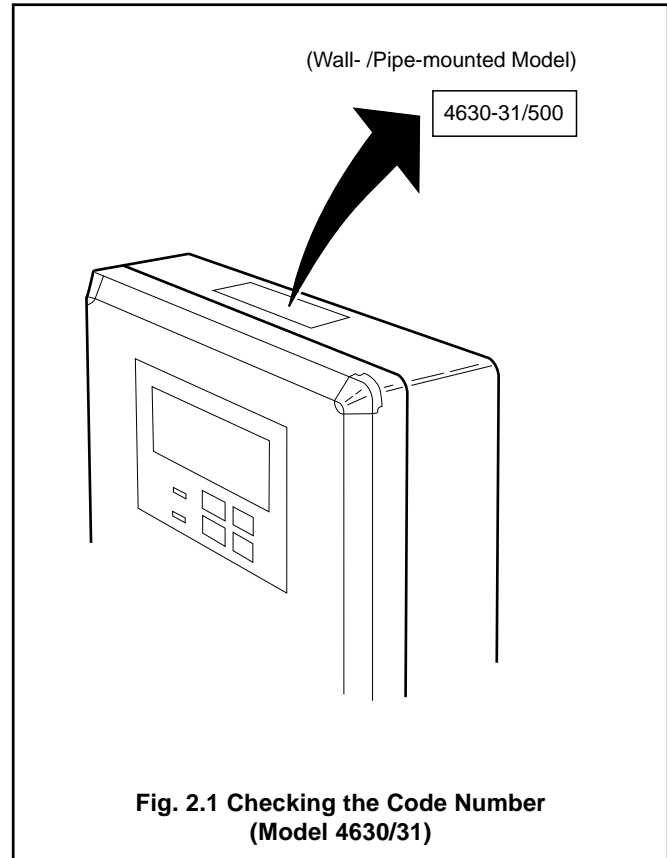

2.1.2 Panel-mounted Instruments – Fig. 2.2

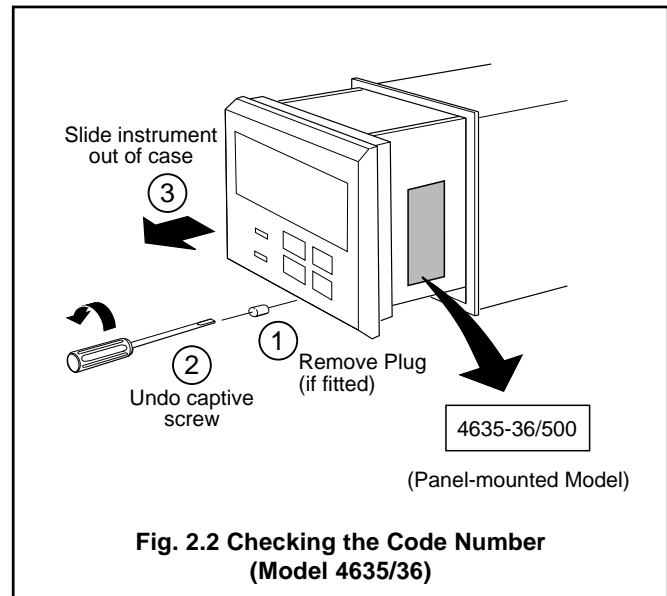

3 MECHANICAL INSTALLATION

3.1 Siting Requirements



Caution.

- Mount in a location free from excessive vibration.
- Mount away from harmful vapours and/or dripping fluids.



Information. It is preferable to mount the instrument at eye level, allowing an unrestricted view of the front panel displays and controls.

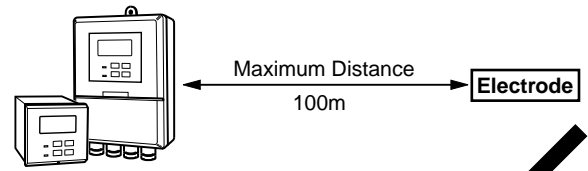

A – Maximum Distance of Instrument to Electrode

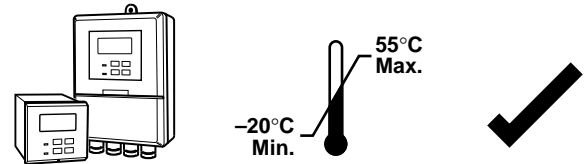

B – Within Temperature Limits

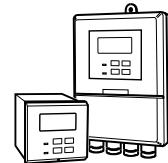

C – Within Environmental Limits

Fig. 3.1 Siting Requirements

...3 MECHANICAL INSTALLATION

3.2 Mounting

3.2.1 Wall-/Pipe-mounted Instruments – Figs. 3.2 and 3.3

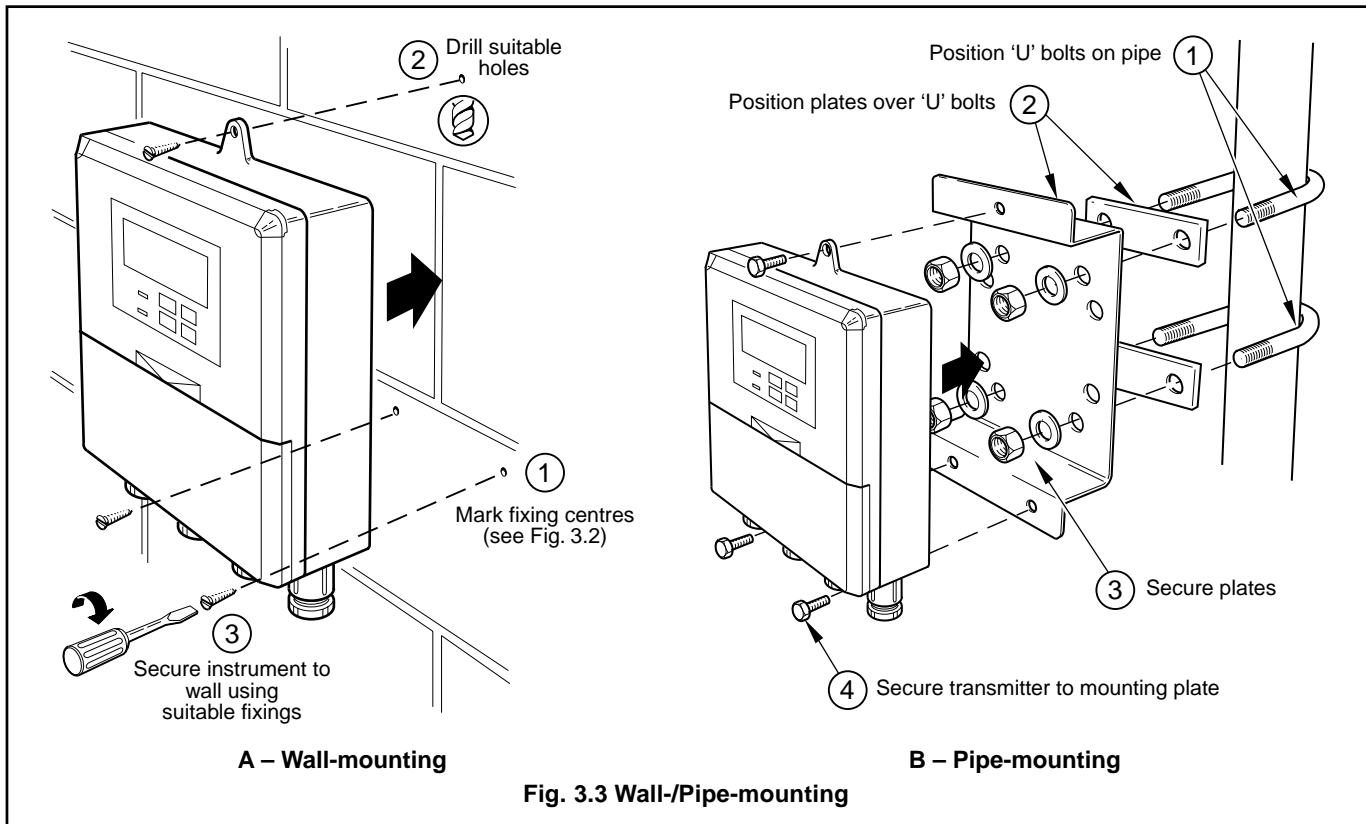
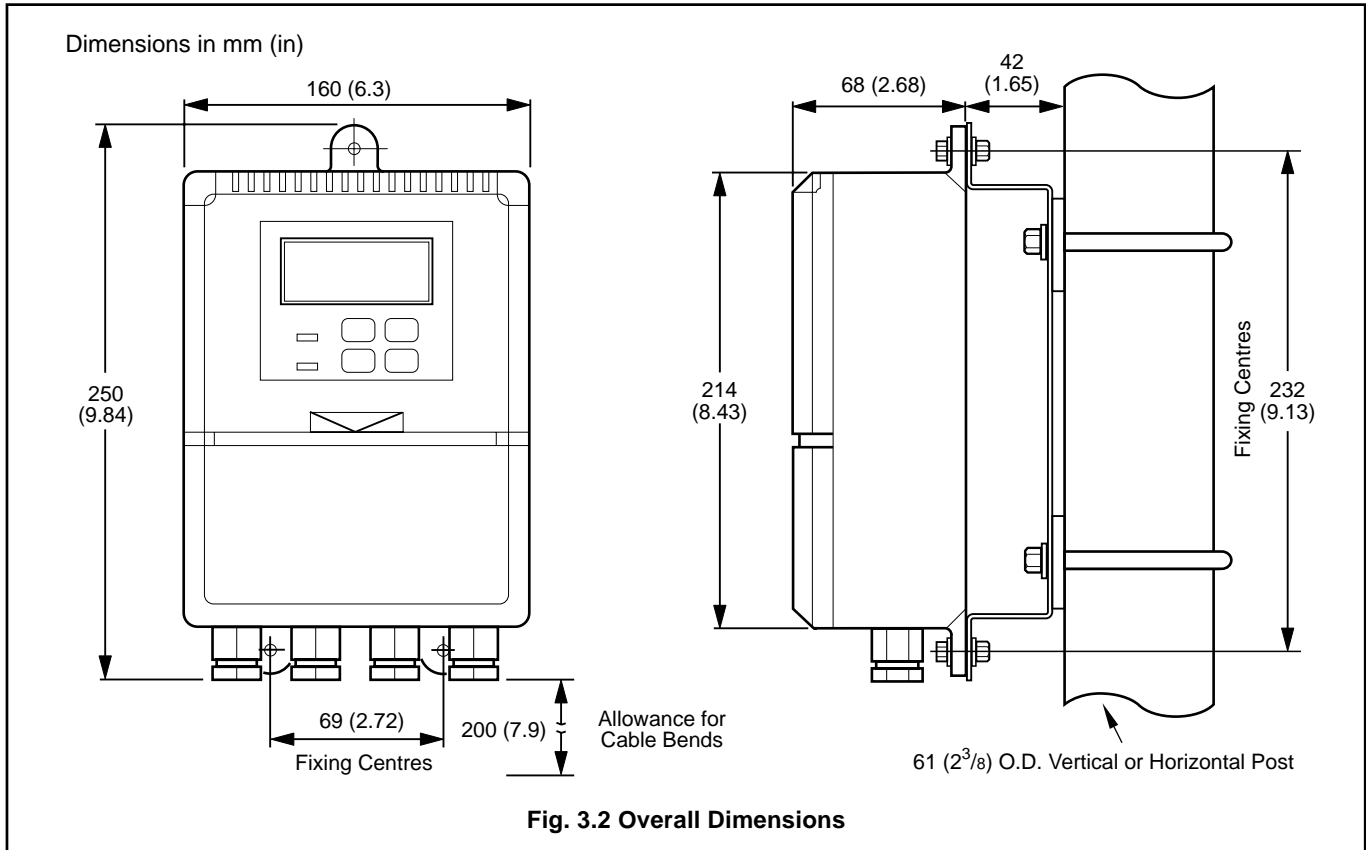

...3.2 Mounting

3.2.2 Panel-mounted Instruments – Figs. 3.4 and 3.5

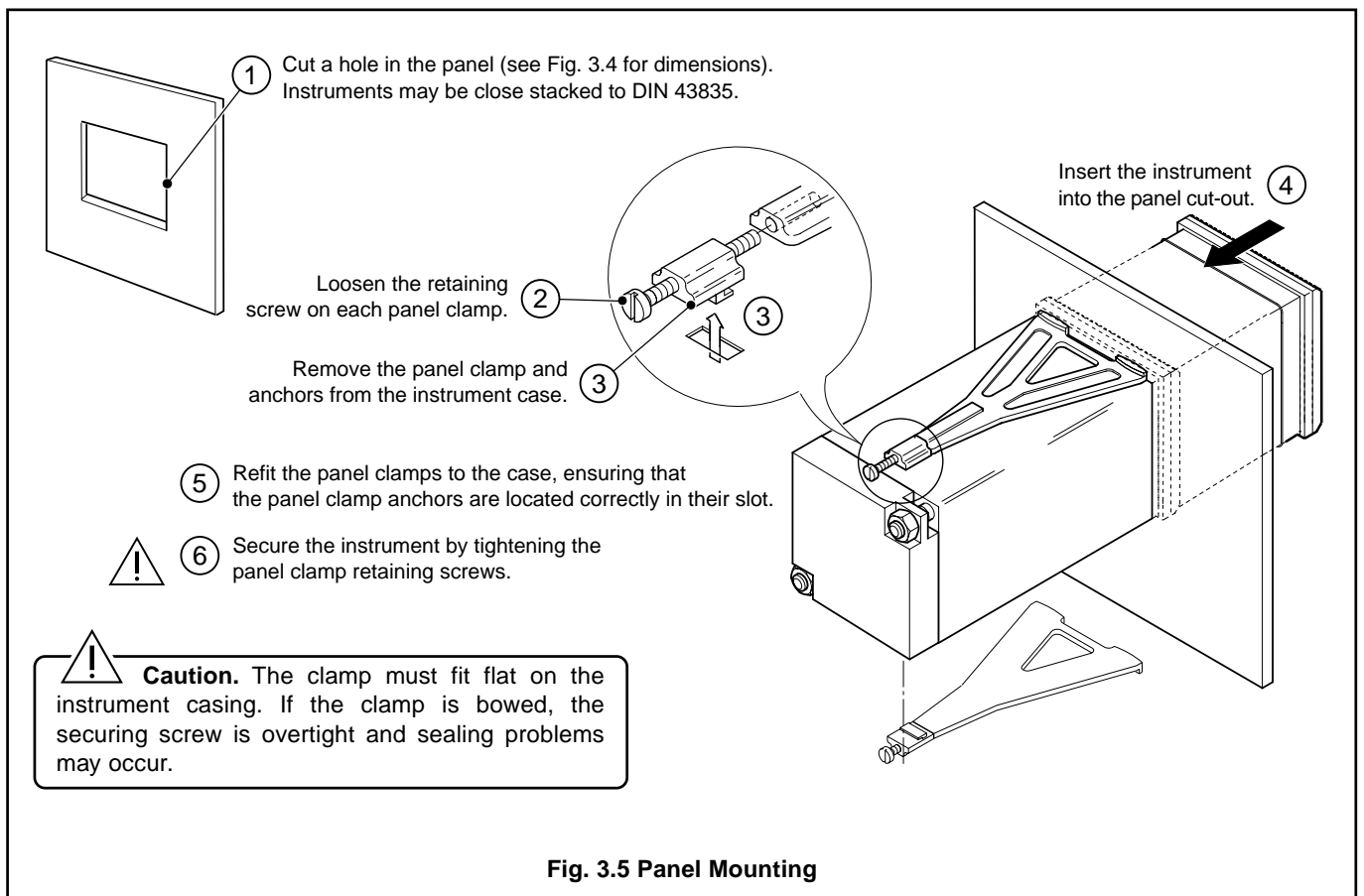
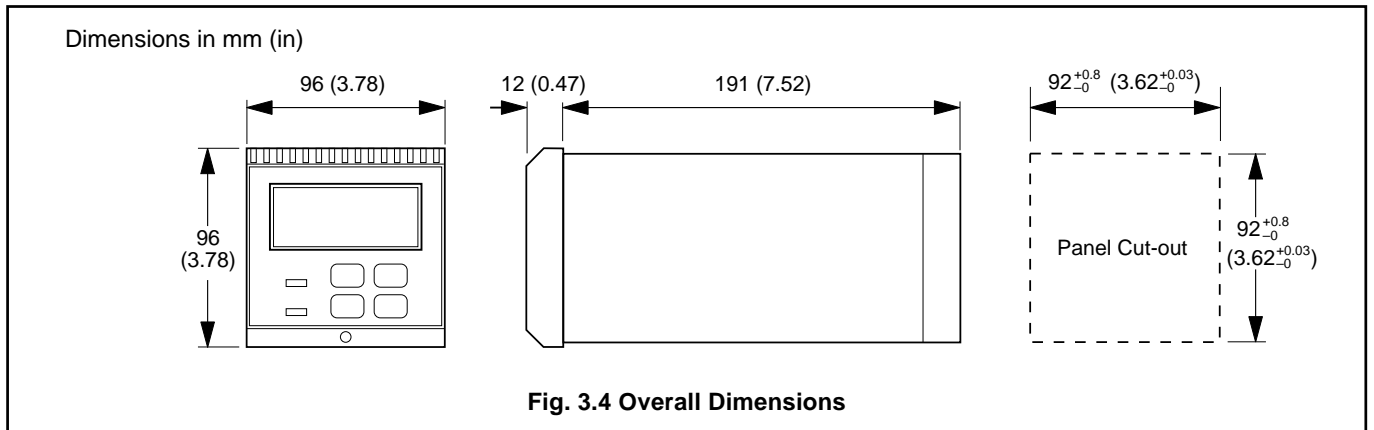

4 ELECTRICAL CONNECTIONS



Warning. Before making any connections, ensure that the power supply, any high voltage-operated control circuits and high common mode voltages are switched off.

4.1 Access to Terminals

4.1.1 Wall-/Pipe-mounted Instruments – Fig. 4.1

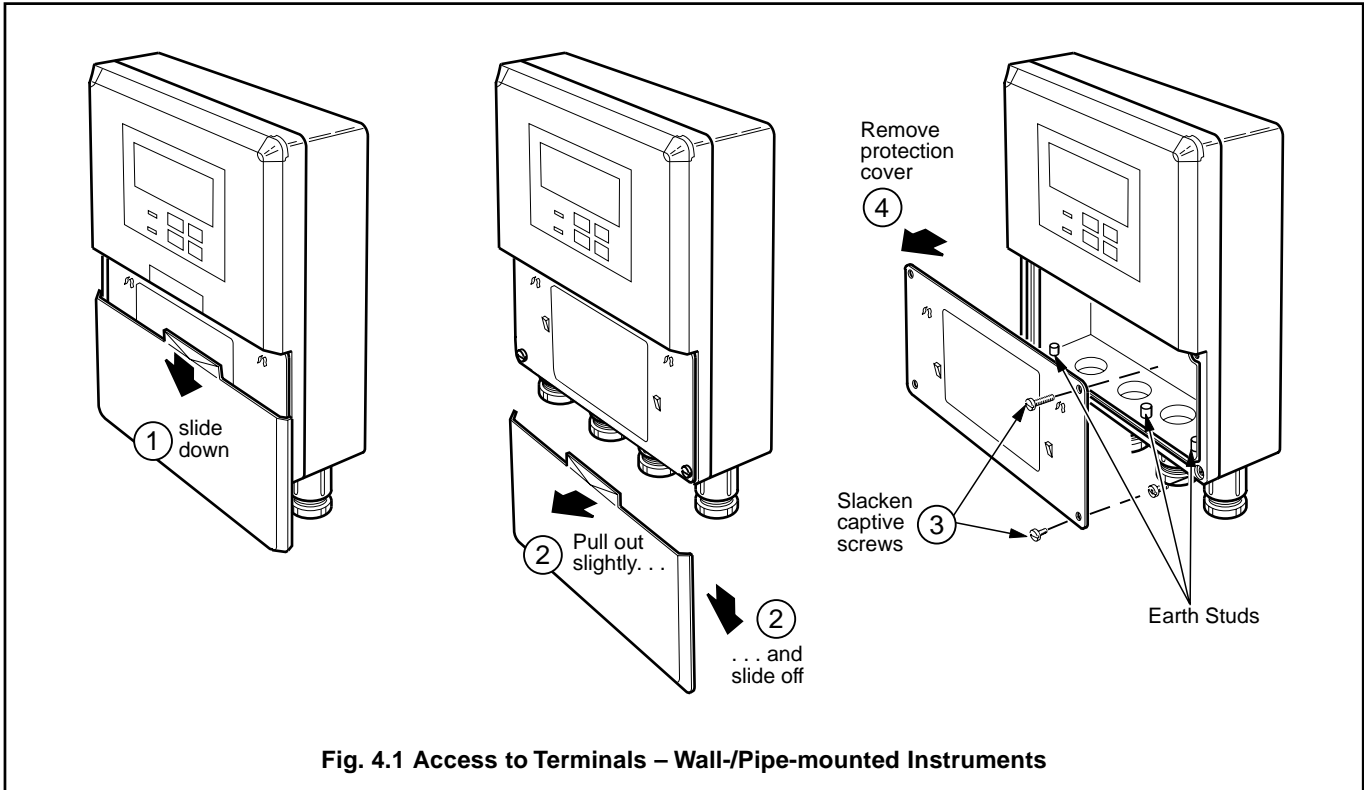

4.1.2 Panel-mounted Instruments – Fig. 4.2

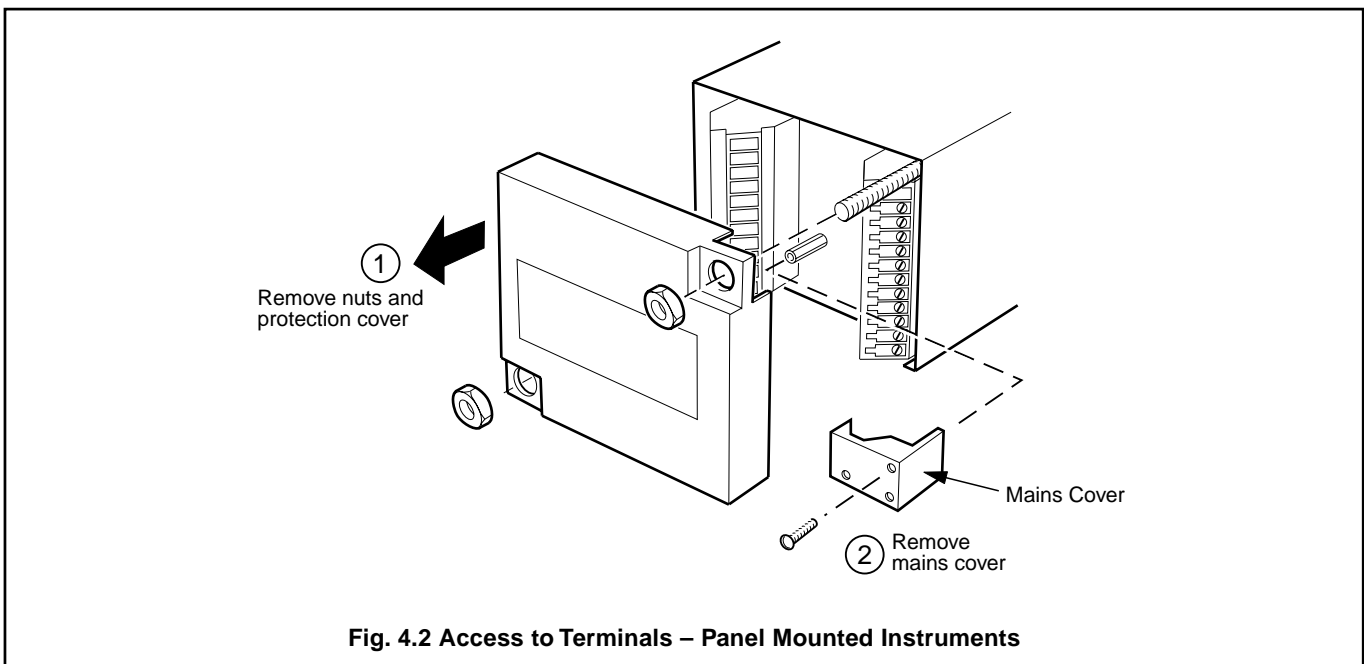

4.2 Connections, General



Information.

- **Earthing (grounding)** – stud terminal(s) is fitted to the transmitter case for bus-bar earth (ground) connection – see Fig. 4.1 or 4.5.
- **Cable routing** – always route signal output/pH electrode cable leads and mains-carrying/relay cables separately, ideally in earthed metal conduit. Use twisted pair output leads or use screened cable with the screen connected to the case earth stud.
Ensure that the cables enter the transmitter through the glands nearest the appropriate screw terminals and are short and direct. Do not tuck excess cable into the terminal compartment.
- **Cable glands & conduit fittings** – ensure a moisture-tight fit when using cable glands, conduit fittings and blanking plugs/bungs (M20 holes). The M16 glands ready-fitted to wall-mounted instruments accept cable of between 4 and 7mm diameter.
- **Relays** –the relay contacts are voltage-free and must be appropriately connected in series with the power supply and the alarm/control device which they are to actuate. Ensure that the contact rating is not exceeded. Refer also to Section 4.2.1 (below) for relay contact protection details when the relays are to be used for switching loads.
- **Retransmission output** – Do not exceed the maximum load specification for the selected current retransmission range – see Section 10, **SPECIFICATION**.

Since the retransmission output is isolated the –ve terminal **must** be connected to earth (ground) if connecting to the isolated input of another device.

4.2.1 Relay Contact Protection and Interference Suppression – Fig. 4.3

If the relays are used to switch loads on and off, the relay contacts can become eroded due to arcing. Arcing also generates radio frequency interference (RFI) which can result in instrument malfunctions and incorrect readings. To minimise the effects of RFI, arc suppression components are required; resistor/capacitor networks for a.c. applications or diodes for d.c. applications. These components can be connected either across the load or directly across the relay contacts. On 4600 Series instruments the RFI components must be fitted to the relay terminal block along with the supply and load wires – see Fig 4.3.

For **a.c. applications** the value of the resistor/capacitor network depends on the load current and inductance that is switched. Initially, fit a 100R/0.022µF RC suppressor unit (part no. B9303) as shown in Fig. 4.3A. If the instrument malfunctions (incorrect readings) or resets (display shows *BBBBB*) the value of the RC network is too low for suppression and an alternative value must be used. If the correct value cannot be obtained, contact the manufacturer of the switched device for details on the RC unit required.

For **d.c. applications** fit a diode as shown in Fig. 4.3B. For general applications use an IN5406 type (600V peak inverse voltage at 3A – part no. B7363).



Note. For reliable switching the minimum voltage must be greater than 12V and the minimum current greater than 100mA.

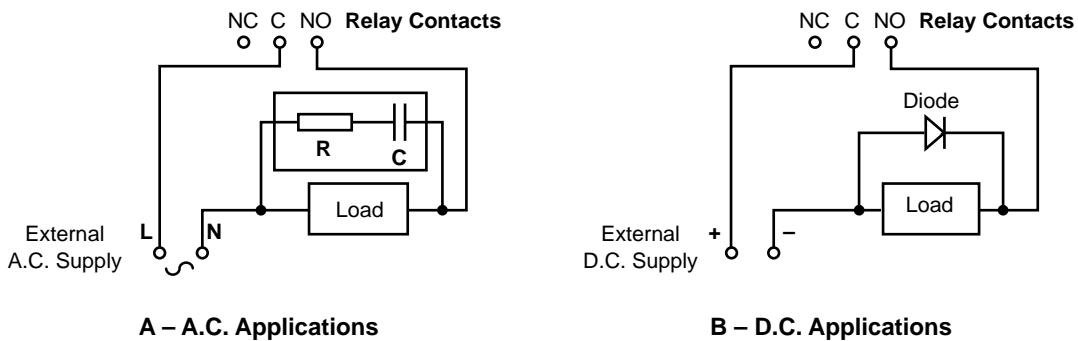

Fig. 4.3 Relay Contact Protection

...4 ELECTRICAL CONNECTIONS

Instrument Type	Terminal Number						Case Earth Stud
	4630 (Wall Mounting)	1 and 3	2	4	5	6	
4635 (Panel Mounting)	10 and 12	11	9	8	7	6	Case Earth Stud
Description							
	Not Used	Signal Input	Reference Input	PT100 Input	PT100 third lead input	PT100 Input	

pH Electrode System Connections

7651 to 7656	Not Used	Glass (Inner Core Coax)	Black Fly Lead (Coax Screen)	White Lead	Red Lead	Red Lead	Yellow Fly Lead (Coax Screen) plus Green Lead
7660 to 7665	Not Used	Glass (Inner Core Coax)	Black Fly Lead (Coax Screen)	White Lead	Red Lead	Red Lead	Yellow Fly Lead (Coax Screen) plus Green Lead
7670 to 7676	Not Used	Glass (Inner Core Coax)	Black Fly Lead (Coax Screen)	White Lead	Red Lead	Red Lead	Not Used
2867	Not Used	Glass (Inner Core Coax)	Screen (Coax Braid)	Not Used	Not Used	Not Used	Not Used
2850, 2873 and 2877	Not Used	Glass (Inner Core Coax)	Black Lead	Green Lead	Red Lead	Red Lead	Coax Screen
2891	Not Used	Glass (Inner Core Coax)	Screen (Coax Braid)	Not Used	Not Used	Not Used	Not Used
7601 to 7605	Not Used	Glass (Inner Core Coax)	Black Lead	Green Lead	Red Lead	Blue Lead	Coax Screen

Redox Electrode System Connections

7651 to 7656	Not Used	Platinum (Inner Core Coax)	Black Fly Lead (Coax Screen)	Not Used	Not Used	Not Used	Not Used
7660 to 7665	Not Used	Platinum (Inner Core Coax)	Black Fly Lead (Coax Screen)	Not Used	Not Used	Not Used	Not Used
7670 to 7676	Not Used	Platinum (Inner Core Coax)	Black Fly Lead (Coax Screen)	Not Used	Not Used	Not Used	Not Used
2867	Not Used	* Screen (Coax Braid)	* Platinum (Inner Core Coax)	Not Used	Not Used	Not Used	Not Used

* **Note.** Electrodes are currently designed to give a reading that is compatible with analog instruments. To obtain correct readings with the 2867 electrode system, the electrode leads need to be reversed as shown.

Table 4.1 Cable Colors for Different pH Electrode System Types

4.3 Connections – Wall-/Pipe-mounted Instruments – Fig. 4.4

Note. Refer to Fig. 4.1 for Access to Terminals.

Caution. Slacken terminal screws fully before making connections.

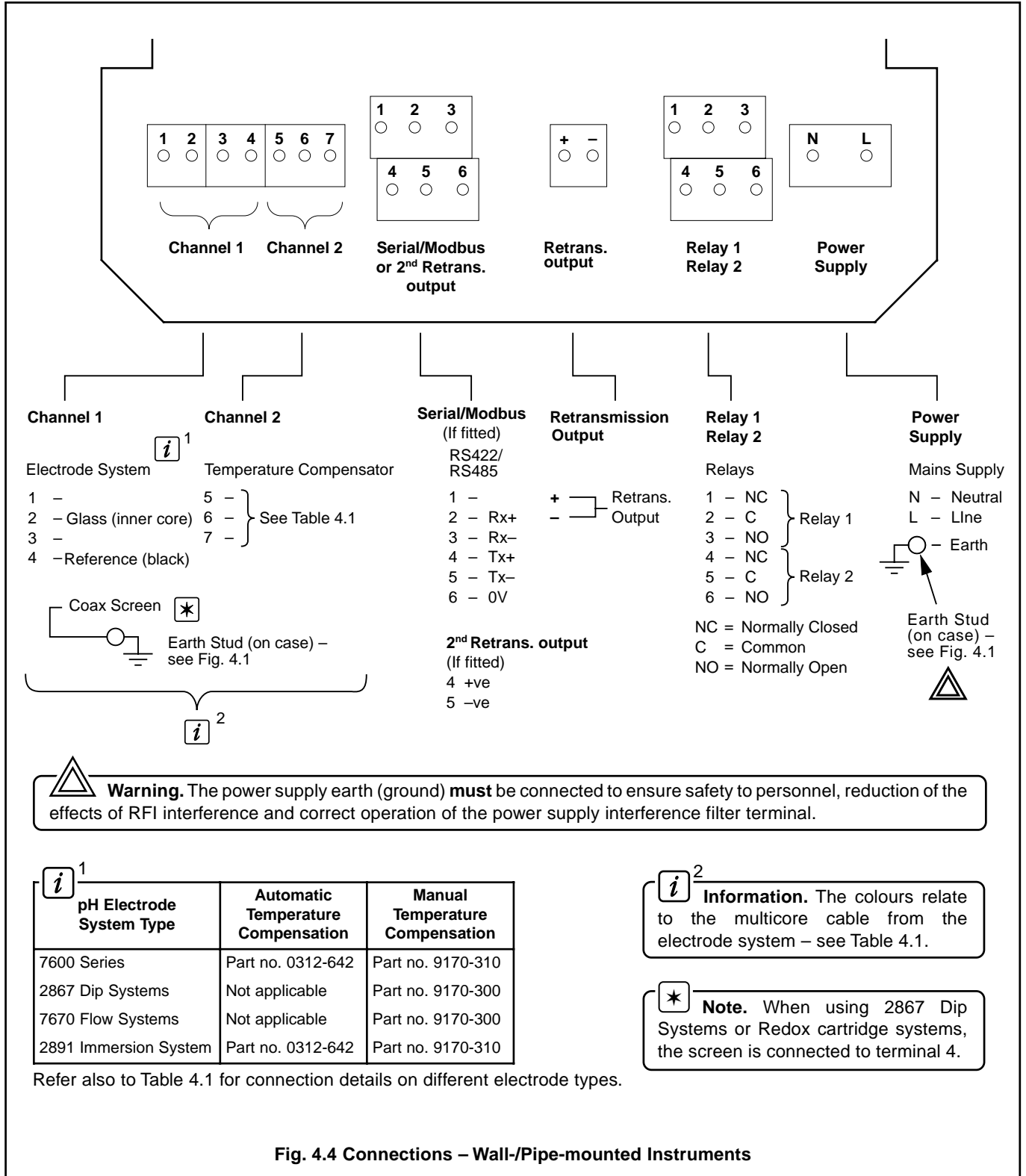

Warning. The power supply earth (ground) **must** be connected to ensure safety to personnel, reduction of the effects of RFI interference and correct operation of the power supply interference filter terminal.

¹ pH Electrode System Type	Automatic Temperature Compensation	Manual Temperature Compensation
7600 Series	Part no. 0312-642	Part no. 9170-310
2867 Dip Systems	Not applicable	Part no. 9170-300
7670 Flow Systems	Not applicable	Part no. 9170-300
2891 Immersion System	Part no. 0312-642	Part no. 9170-310

²
Information. The colours relate to the multicore cable from the electrode system – see Table 4.1.

Note. When using 2867 Dip Systems or Redox cartridge systems, the screen is connected to terminal 4.

Refer also to Table 4.1 for connection details on different electrode types.

Fig. 4.4 Connections – Wall-/Pipe-mounted Instruments

...4 ELECTRICAL CONNECTIONS

4.4 Connections – Panel-mounted Instruments – Fig. 4.5

Note. Refer to Fig. 4.1 for Access to Terminals.

Caution. Slacken terminal screws fully before making connections.

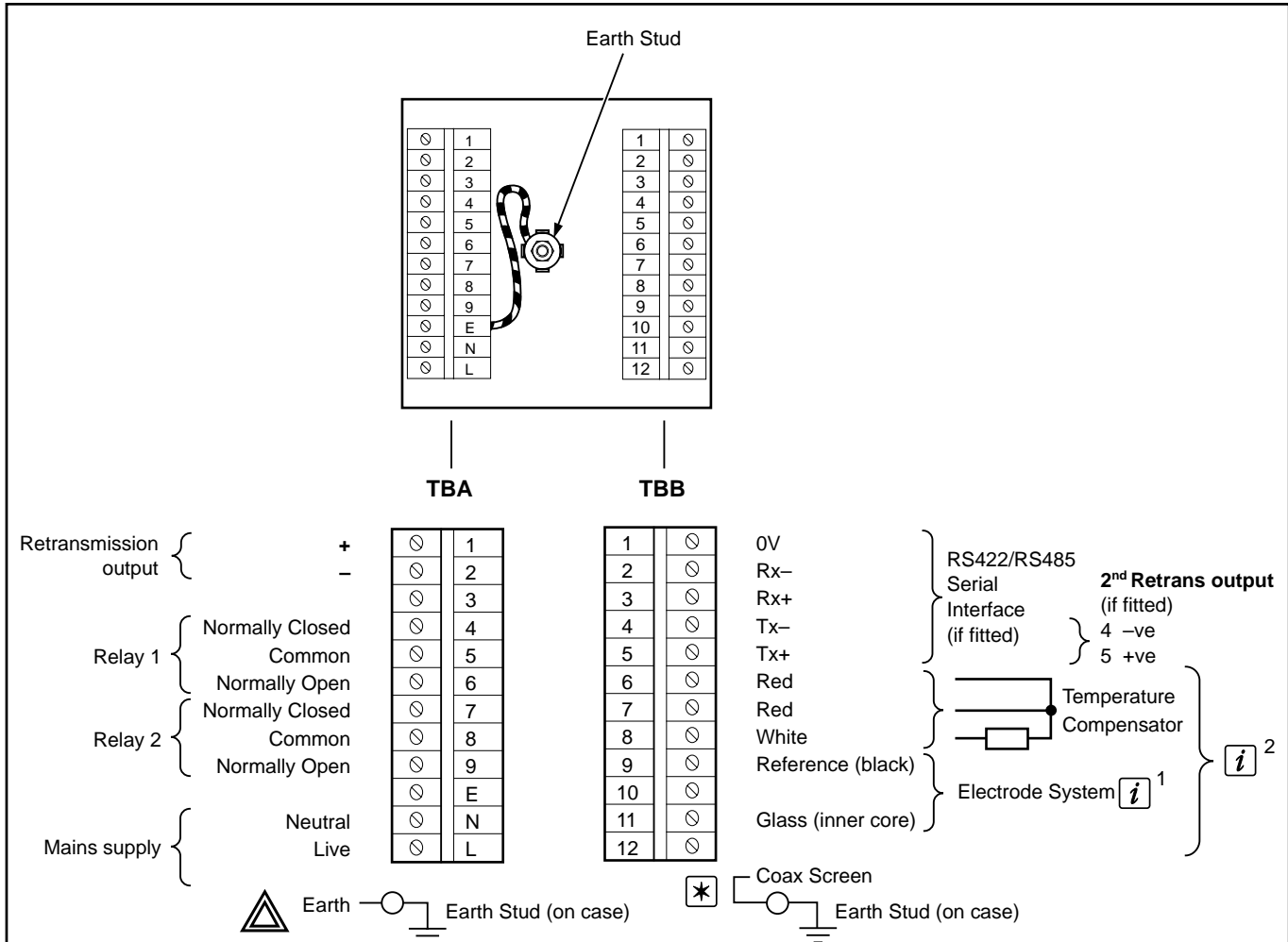

Warning. The power supply earth (ground) **must** be connected to ensure safety to personnel, reduction of the effects of RFI interference and correct operation of the power supply interference filter. Connect the earth lead directly to the case earth stud and **not** to the 'E' terminal.

¹ pH Electrode System Type	Automatic Temperature Compensation	Manual Temperature Compensation
7600 Series	Part no. 0312-642	Part no. 9170-310
2867 Dip Systems	Not applicable	Part no. 9170-300
7670 Flow Systems	Not applicable	Part no. 9170-300
2891 Immersion System	Part no. 0312-642	Part no. 9170-310

Refer also to Table 4.1 for connection details on different electrode types.

²
Information. The colours relate to the multicore cable from the electrode system – see Table 4.1.

Note. When using 2867 Dip Systems or Redox cartridge systems, the screen is connected to terminal 9.

Fig. 4.5 Connections – Panel-mounted Instruments

4.5 Selecting the Mains Voltage

4.5.1 Wall-/Pipe-mounted Instruments – Fig. 4.6

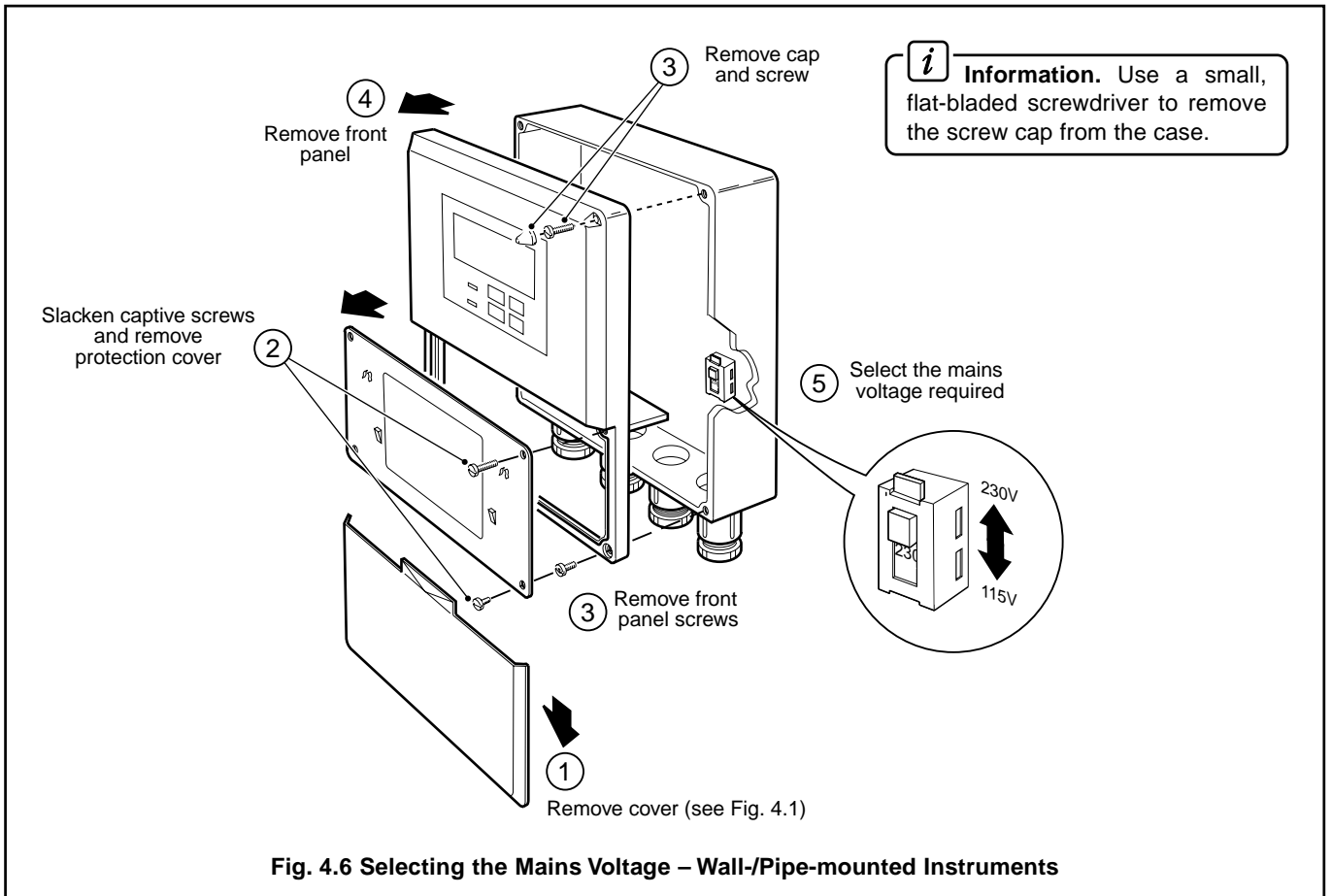

4.5.2 Panel-mounted Instruments – Fig. 4.7

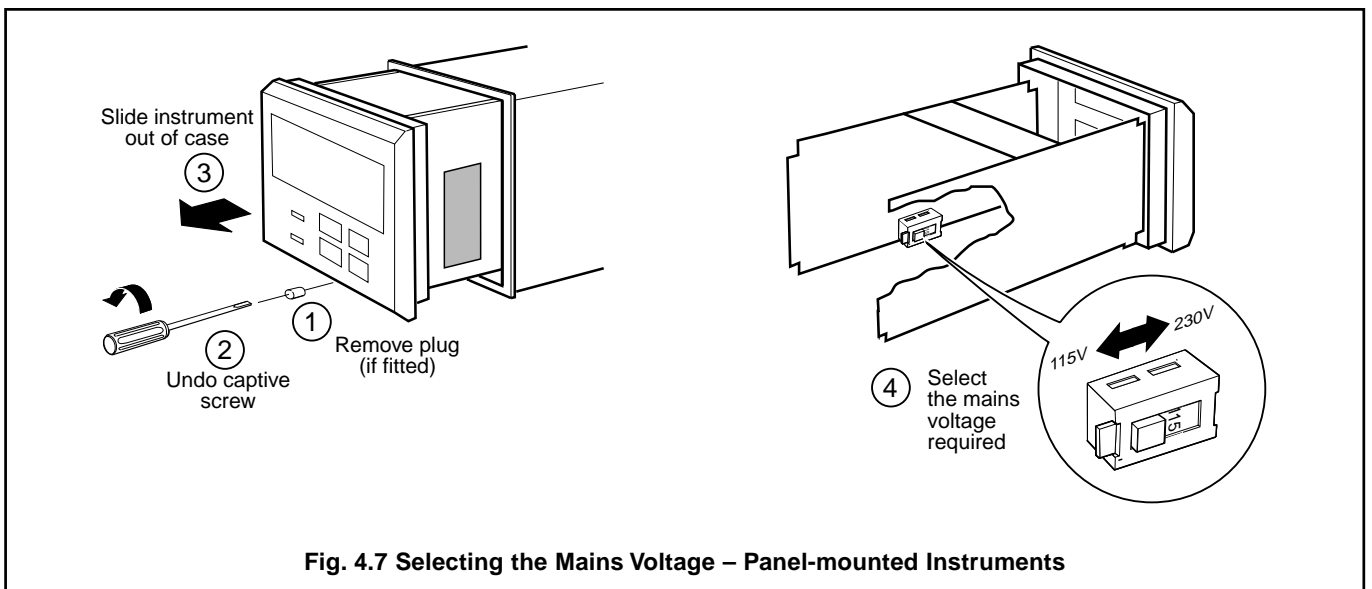

5 CONTROLS AND DISPLAYS

5.1 Displays – Fig. 5.1

The display comprises a 5-digit, 7-segment digital upper display line and a 16-character dot-matrix lower display line. The upper display line shows actual values of pH, temperature, alarm set points or programmable parameters. The lower display line shows the associated units or programming information.

5.2 Controls Familiarization – Figs. 5.1 and 5.2

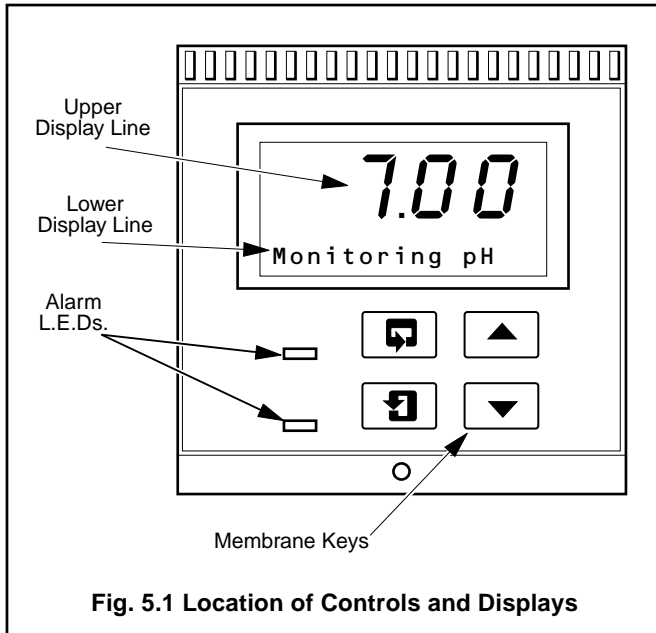

Fig. 5.1 Location of Controls and Displays

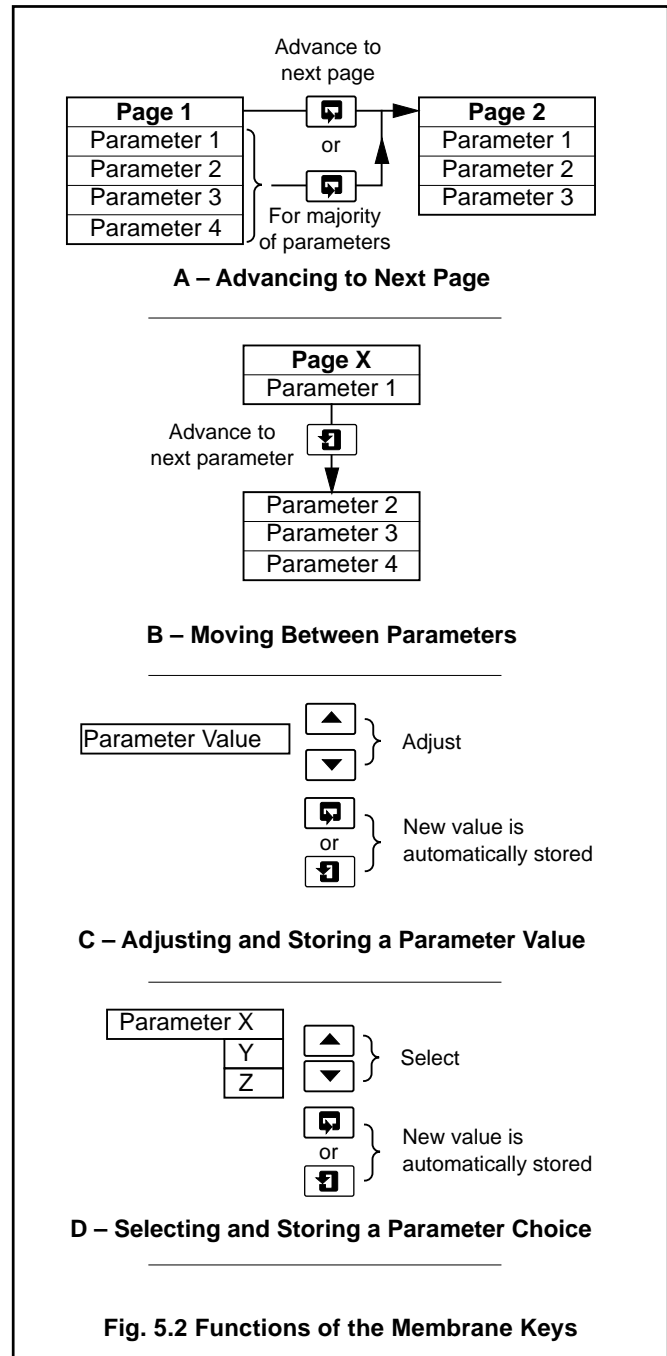

Fig. 5.2 Functions of the Membrane Keys

6 OPERATION

6.1 Instrument Start-up

Ensure all electrical connections have been made correctly and switch on the power supply. If the instrument is being commissioned for the first time its parameters must be programmed, as detailed in Section 7, before carrying out a pH Calibration.

6.2 Operation – pH Measurement Mode

Operation in the pH measurement mode comprises an **Operating Page** and a **pH Calibration Page**. The **Operating Page** is a general use page in which parameters can be viewed but not altered. To alter or program a parameter refer to the programming pages in Section 7.

Three calibration procedures are available, **Single Point**, **Two-point (Manual Mode)** and **Two-point (Automatic Mode)**. Refer to Table 6.1 for an overview of each procedure.

A 5-digit calibration code is used to prevent unauthorized access to the pH calibration page. The value is preset at 00000 to allow access during commissioning but should be altered to a unique value, known only to authorized operators, in the **Set Up Alarms Page** – see Section 7.4.

	Calibration Type		
	Single Point	Two-point (Manual Mode)	Two-point (Automatic Mode)
Buffers Used	Used with any buffer solution.	Used with any buffer solution not listed in Table 6.2 on page 17. This mode requires manual input of the buffer values.	Used with ABB buffers or Non-ABB buffers – see Table 6.2 on page 17. This mode offers automatic recognition of the 2 buffers.
Temperature Compensation	Requires temperature of buffers to be measured and corresponding buffer value entered into the transmitter. (Refer to the data sheet accompanying the buffer solution).	Requires temperature of buffers to be measured and corresponding buffer value entered into the transmitter. (Refer to the data sheet accompanying the buffer solution).	The instrument automatically adjusts buffer values for changes in buffer temperature. (Temperature compensation ON)
Calibration Process	A period of 3 minutes is allowed for the electrode response to stabilize in the buffer. During this time, the mV response is displayed. If stability is not achieved the message SLOW RESPONSE is displayed. If stability is achieved within the 3 minute period and the calibration is successful, a CALIBRATION PASS message is displayed. See Table 6.3 on page 20 for an explanation of all calibration messages.	A period of 3 minutes is allowed for the electrode response to stabilize in the buffer. During this time, the mV response is displayed. If stability is not achieved the message SLOW RESPONSE is displayed. If stability is achieved within the 3 minute period and the calibration is successful, the procedure is advanced automatically to the next stage. See Table 6.3 on page 20 for an explanation of all calibration messages.	A period of 3 minutes is allowed for the electrode response to stabilize in the buffer. During this time, the mV response is displayed. If stability is not achieved the message SLOW RESPONSE is displayed. If stability is achieved within the 3 minute period and the calibration is successful, the procedure is advanced automatically to the next stage. See Table 6.3 on page 20 for an explanation of all calibration messages.
Notes	A single point calibration compensates for any drift in the electrode system. The pH Check Value indicates the amount of drift in pH units. The % Slope Value is not affected and remains at the value from the last successful 2 point calibration.	The pH Calibration Minimum Slope Value is programmable – see Set Min. Slope % parameter in Section 7.3, page 25. The % Slope Value parameter provides an early warning that the response from the electrode system is deteriorating. Calibration fails if the % Slope Value is 20% lower than pH Calibration Minimum Slope Value setting.	The pH Calibration Minimum Slope Value is programmable – see Set Min. Slope % parameter in Section 7.3, page 25. The % Slope Value parameter provides an early warning that the response from the electrode system is deteriorating. Calibration fails if the % Slope Value is 20% lower than pH Calibration Minimum Slope Value setting.

Table 6.1 Calibration Overview



Information.

- **pH Check Value** – is an indication of the offset of the electrode system and is expressed in pH units. 7pH is the optimum value for glass electrode systems and 0pH for Antimony systems. The amount the check value changes after each calibration reflects the amount of electrical drift from the electrode system.
- **% Slope Value** – is an indication of the response of the electrode system with respect to the expected theoretical response. The value should be between the programmed minimum % slope value (see **pH Calibration Minimum Slope Value** in the **Set Up Parameters Page** on page 25) and 105% for a successful calibration.

...6 OPERATION

6.2.1 Operating Page

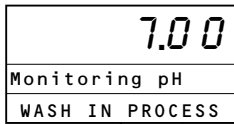

Press to advance to next page
or
Press to advance to next parameter

Press to advance to next page
or
Press to advance to next parameter

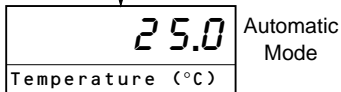

or

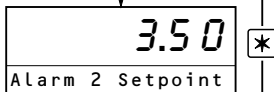
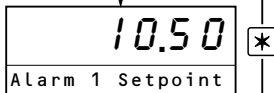
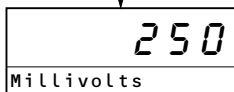
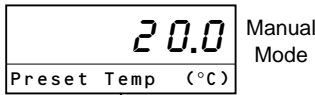

Measured pH

The measured pH is displayed.

If the Water Wash cycle is selected (Models 4631 or 4636 only), an alternative message, **WASH IN PROCESS**, is displayed. The Alarm 1 status and the retransmission value are held in their pre-cycle condition for the duration of the wash cycle.

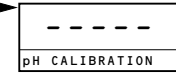

These two keys are used to advance to all subsequent parameters and pages.

Sample Temperature:

is displayed in either °C or °F. The display units are programmable – see Section 7.3, **Set Up Parameters Page**. Automatic or manual mode is also selected in the **Set Up Parameters Page**.

Preset Temperature:

value is displayed in either °C or °F. The display units are programmable – see Section 7.3, **Set Up Parameters Page**. The preset temperature value is also set in the **Set Up Parameters Page**.

Measured Millivolts

The sensor reading is displayed in millivolts.

Alarm 1 Set Point

The set point value and relay/l.e.d. action are programmable – see Section 7.4, **Set Up Alarms Page**.

Note. This display is bypassed if Alarm 1 Type has been set to **F a i l** or **O f f** – see Section 7.4, **Set Up Alarms Page**.

Alarm 2 Set Point

The set point value and relay/l.e.d. action are programmable – see Section 7.4, **Set Up Alarms Page**.

Note. This display is bypassed if the **Water Wash** sequence is selected or if Alarm 2 Type has been set to **F a i l** or **O f f** – see Section 7.4, **Set Up Alarms Page**.

Continued on next page.

...6.2.1 Operating Page

Continued from previous page.

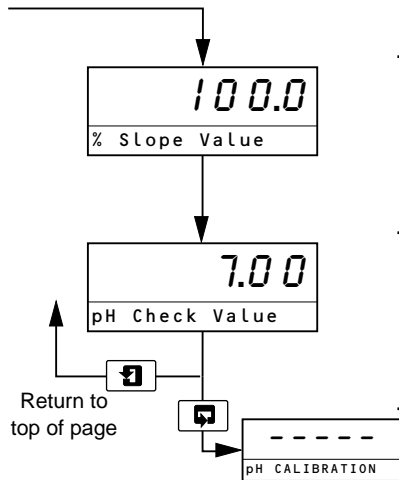
**Slope Value:**

a value between the programmed minimum % slope value (see **pH Calibration Minimum Slope Value** in the **Set Up Parameters Page** on page 25) and 105% should be displayed. If the value is outside these limits the electrode system must be checked.

pH Check Value:

is displayed as an additional indication of electrode system condition; 7pH being the optimum value for glass electrodes and 0pH for Antimony electrodes.

Advance to **PH Calibration Page** – see Sections 6.2.2 to 6.2.4.

...6 OPERATION

6.2.2 Single Point pH Calibration

A single point calibration may be carried out in preference to a two point calibration provided a two point calibration has been carried out since installing the instrument. This procedure assumes an electrode pair with perfect Nernstian response, i.e. 59.16mV per pH change at 25°C. Refer to Table 6.1 on Page 13 for an overview of the calibration procedure.

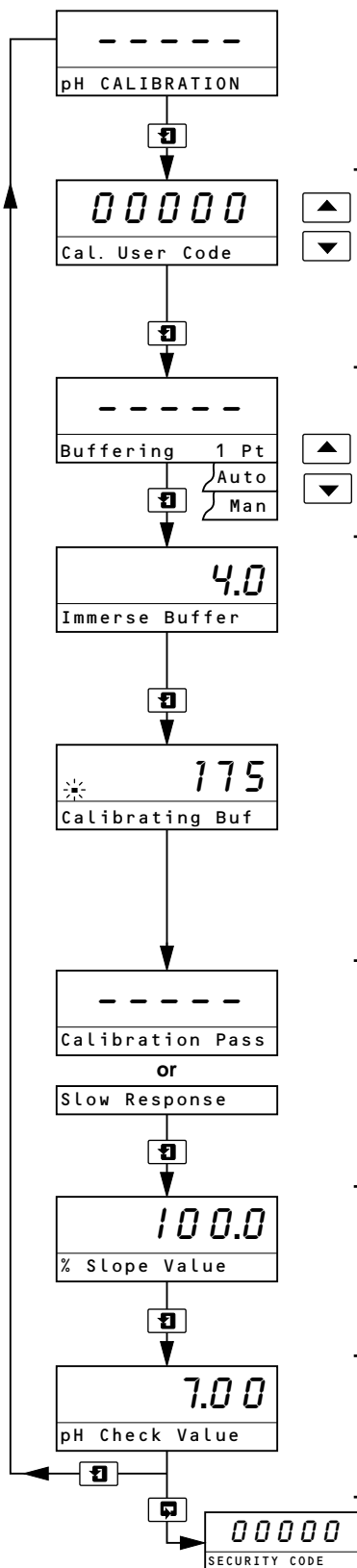

Note. Pressing the  key at any point during the calibration sequence prior to the pH Check Value parameter aborts calibration and returns the display to the top of the **Operating Page**.

Advance to next parameter.

Calibration Access

Enter the required calibration code number, between 00000 and 19999. If an incorrect value is entered, access to pH calibration is prevented and the display returns to the top of the **pH Calibration Page**.

Advance to next parameter.

Buffering Calibration Type

Select single point buffering (1 Pt).

Advance to next parameter.

Buffer Calibration

Immerse the electrode in the buffer solution. Set the upper display line to the temperature-corrected pH value of the buffer solution – refer to the datasheet accompanying the solution.

Advance to initiate calibration. A flashing dot indicates that calibration is in progress.

The upper display line shows the sensor e.m.f.

- When a stable e.m.f. is detected, the instrument automatically advances to the next parameter and the calibration message appropriate to the result of the calibration is displayed.
- If a stable e.m.f. is not detected, the calibration message **Slow Response** is displayed.

Calibration Message

Refer to Table 6.3 on page 20 for calibration message clarification.

Advance to next parameter.

Slope Value

The slope value remains fixed from the last 2-point calibration.

Advance to next parameter.

pH Check Value:

is displayed as an additional indication of electrode system condition; 7pH being the optimum value for glass electrodes and 0pH for Antimony electrodes.

Advance to **Access to Secure Parameters**.

6.2.3 Two-point pH Calibration (Automatic Mode)

An automatic pH calibration involves standardizing the instrument and electrode system using ABB supplied buffer solutions or non-ABB buffer solutions of 4, 7, 9 and 10pH. Before starting pH calibration, check the **Temp Comp** setting in the **Set Up Parameters Page** – see Section 7.3. Refer to Table 6.1 on Page 13 for an overview of the calibration procedure.

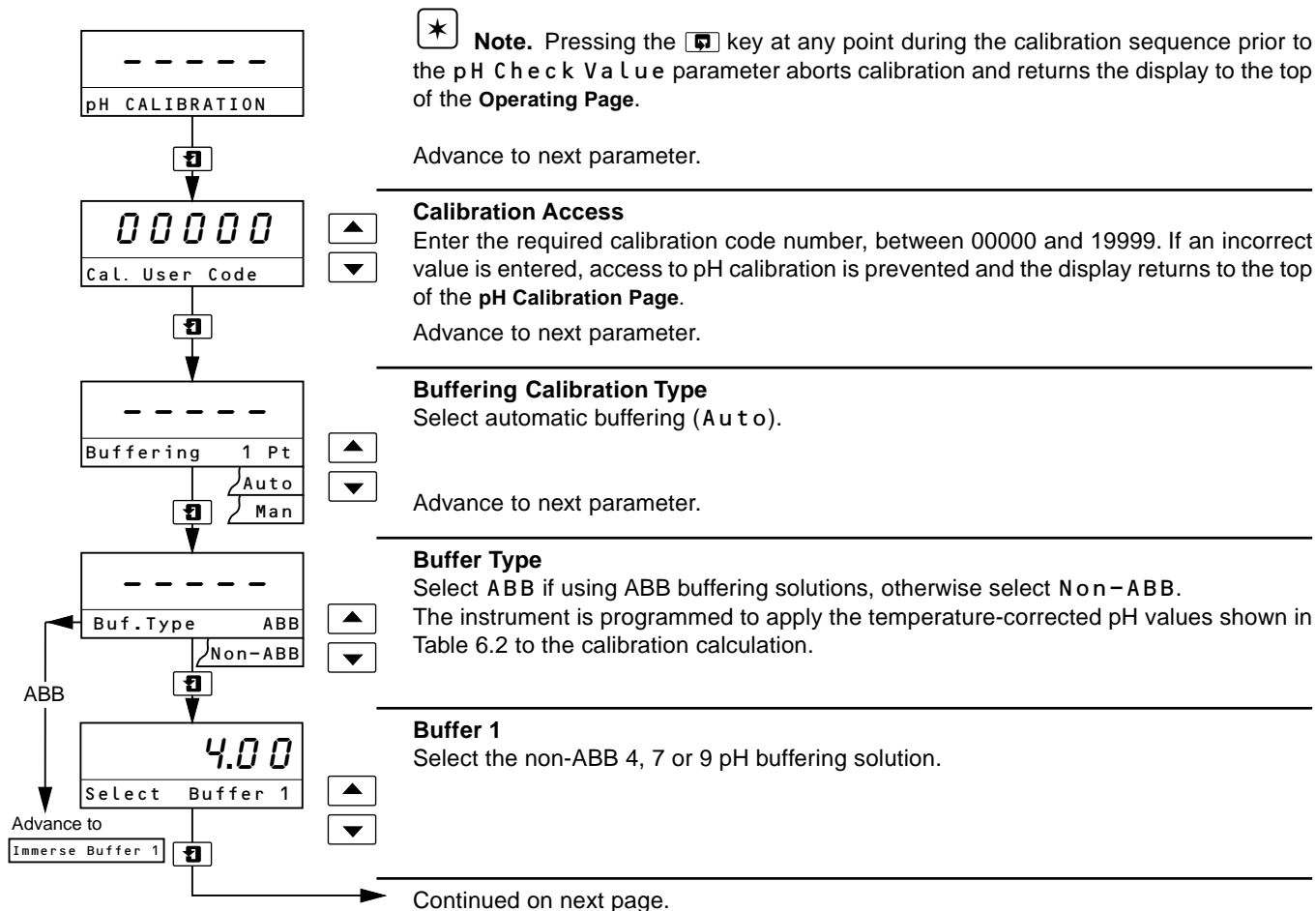

Temp (°C)	Non-ABB Buffer Solutions				ABB Buffer Solutions	
	4pH	7pH	9pH	10pH	4pH	9pH
0	4.05	7.13	9.24	10.26	4.00	9.475
5	4.04	7.07	9.16	10.17	–	–
10	4.02	7.05	9.11	10.11	3.997	9.347
15	4.01	7.02	9.05	10.05	–	–
20	4.00	7.00	9.00	10.00	4.00	9.233
25	4.01	6.98	8.95	9.94	4.005	9.182
30	4.01	6.98	8.91	9.89	4.011	9.134
35	4.01	6.96	8.88	9.84	4.022	9.074
40	4.01	6.95	8.85	9.82	4.027	9.051
50	4.00	6.95	8.79	9.74	4.050	8.983
60	4.00	6.96	8.73	9.67	4.080	8.932
70	4.00	6.96	8.70	9.62	4.116	8.898
80	4.00	6.97	8.66	9.55	4.159	8.88
90	4.00	7.00	8.64	9.49	4.208	8.84

Table 6.2 Non-ABB and ABB Buffer Solution Temperature-corrected pH Values

...6 OPERATION

...6.2.3 Two-point pH Calibration (Automatic Mode)

Continued from previous page.

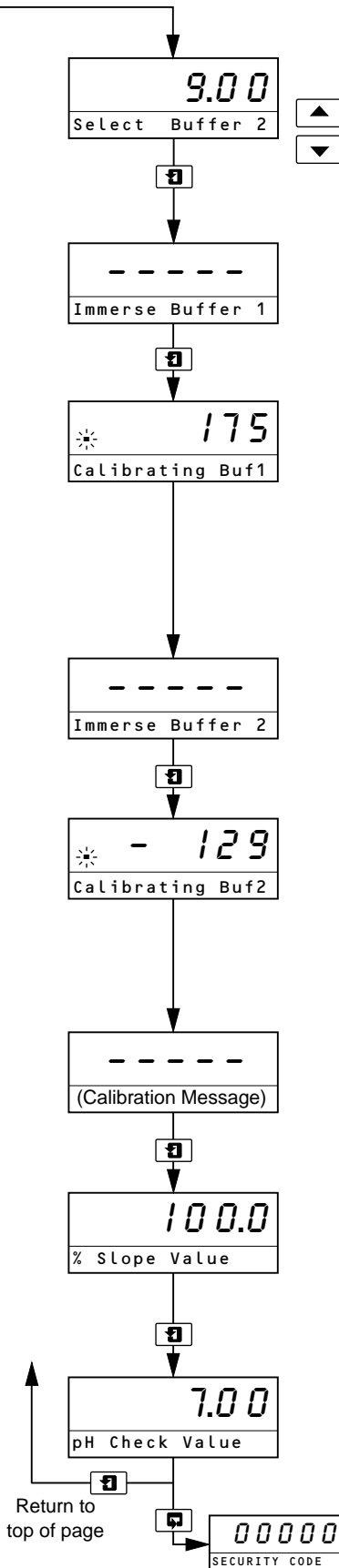

Buffer 2

Select the non-ABB 7, 9 or 10 pH buffering solution.



Note. The buffering solution selected for Buffer 2 must always be at least 1pH value greater than the solution selected for Buffer 1; e.g. if Buffer 1 was set to 7pH, Buffer 2 must be set to either 9 or 10pH.

Buffer 1 Calibration

Immerse the electrode and temperature compensator in either the ABB 4pH buffer solution or the non-ABB buffer 1 solution selected earlier.

Advance to initiate calibration. A flashing dot indicates that calibration is in progress.

The upper display line shows the sensor e.m.f.

- When a stable e.m.f. is detected and calibration is successful, the instrument automatically advances to the next parameter.
- If a stable e.m.f. is not detected, the instrument automatically advances to the **Calibration Message** parameter and the message **S L o w R e s p o n s e** is displayed.
- If calibration is not successful, the instrument automatically advances to the **Calibration Message** parameter and the appropriate message is displayed.

Buffer 2 Calibration

Immerse the electrode and temperature compensator in either the ABB 9pH buffer solution or the non-ABB buffer 2 solution selected earlier.

Advance to initiate calibration. A flashing dot indicates that calibration is in progress.

The upper display line shows the sensor e.m.f.

- When a stable e.m.f. is detected, the instrument automatically advances to the next parameter and the calibration message appropriate to the result of the calibration is displayed.
- If a stable e.m.f. is not detected, the calibration message **S L o w R e s p o n s e** is displayed.

Calibration Message

Refer to Table 6.3 on page 20 for calibration message clarification. If the calibration has failed, advance to the next two parameters for diagnostic information.

Advance to next parameter.

Slope Value

A value between the programmed minimum % slope value (see **pH Calibration Minimum Slope Value** in the **Set Up Parameters Page** on page 25) and 105% should be displayed. If the value is outside these limits the electrode system must be checked.

Advance to next parameter.

pH Check Value:

is displayed as an additional indication of electrode system condition; 7pH being the optimum value for glass electrodes and 0pH for Antimony electrodes.

Advance to **Access to Secure Parameters.**

6.2.4 Two-point pH Calibration (Manual Mode)

A manual pH calibration involves standardizing the instrument and the electrode system using any two suitable buffer solutions which give a reasonable span and encompass the anticipated measuring range. Before starting pH calibration, check the **Temp Comp** setting in the **Set Up Parameters Page** – see Section 7.3. Refer to Table 6.1 on Page 13 for an overview of the calibration procedure.

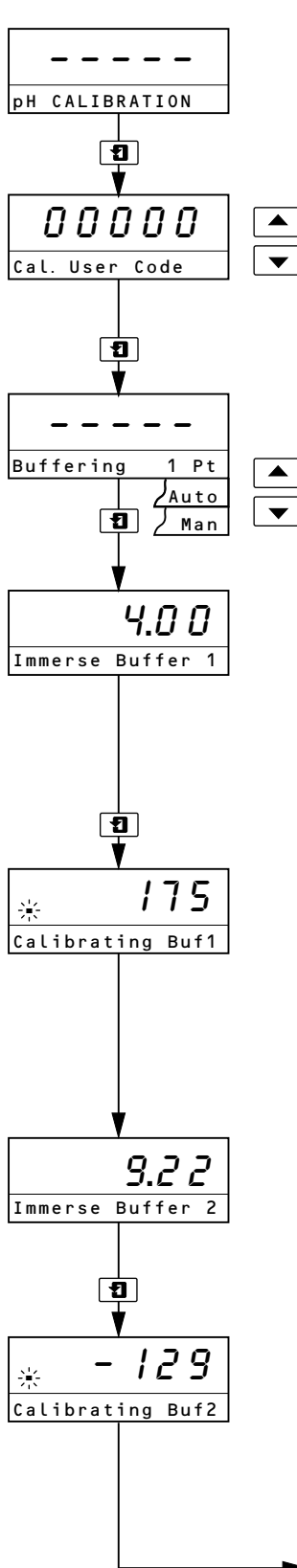

Note. Pressing the  key at any point during the calibration sequence prior to the pH Check Value parameter aborts calibration and returns the display to the top of the **Operating Page**.

Advance to next parameter.

Calibration Access

Enter the required calibration code number, between 00000 and 19999. If an incorrect value is entered, access to pH calibration is prevented and the display returns to the top of the **pH Calibration Page**.

Advance to next parameter.

Buffering Calibration Type

Select manual buffering (**Man**).

Advance to next parameter.

Buffer 1 Calibration

Ensure the Preset Temp parameter in the **Set Up Parameters Page** is set to the temperature of the buffer solutions to be used – see Section 7.3.

Immerse the electrode in the first buffer solution. Set the upper display line to the temperature-corrected pH value of the buffer solution – refer to the datasheet accompanying the solution.

Advance to initiate calibration. A flashing dot indicates that calibration is in progress.

The upper display line shows the sensor e.m.f.

- When a stable e.m.f. is detected and calibration is successful, the instrument automatically advances to the next parameter.
- If a stable e.m.f. is not detected, the instrument automatically advances to the **Calibration Message** parameter and the message **S L o w R e s p o n s e** is displayed.
- If calibration is not successful, the instrument automatically advances to the **Calibration Message** parameter and the appropriate message is displayed.

Buffer 2 Calibration

Immerse the electrode in the second buffer solution. Set the upper display line to the temperature-corrected pH value of the buffer solution – refer to the datasheet accompanying the solution.

Advance to initiate calibration. A flashing dot indicates that calibration is in progress.

The upper display line shows the sensor e.m.f.

- When a stable e.m.f. is detected, the instrument automatically advances to the next parameter and the calibration message appropriate to the result of the calibration is displayed.
- If a stable e.m.f. is not detected, the calibration message **S L o w R e s p o n s e** is displayed.

Continued on next page.

...6 OPERATION

...6.2.4 Two-point pH Calibration (Manual Mode)

Continued from previous page

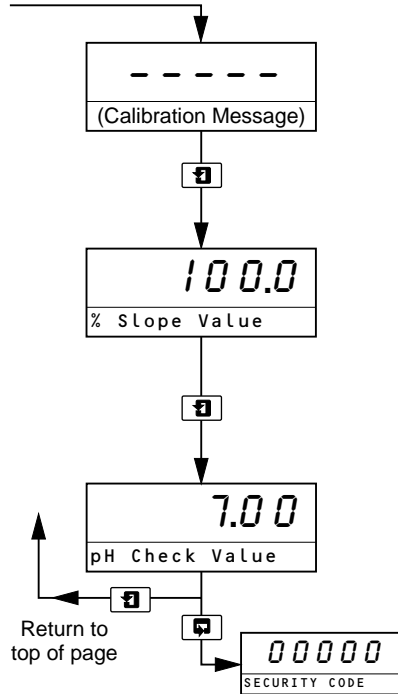

Calibration Message

Refer to Table 6.3 below for calibration messages clarification. If the calibration has failed, advance to the next two parameters for diagnostic information.

Advance to next parameter.

Slope Value

A value between the programmed minimum % slope value (see **pH Calibration Minimum Slope Value** in the **Set Up Parameters Page** on page 25) and 105% should be displayed. If the value is outside these limits the electrode system must be checked.

Advance to next parameter.

pH Check Value:

is displayed as an additional indication of electrode system condition; 7pH being the optimum value for glass electrodes and 0pH for Antimony electrodes.

Advance to **Access to Secure Parameters**.

Calibration Message	Min.	Max.	Explanation	Action
Calibration Pass	40 to 70%	105%	The new calibration coefficients are used	None
Low % Slope	60 to 90%	60 to 90%	The new calibration coefficients are used	The electrode pair are becoming fatigued – replacement is recommended
Slow Response	–	–	The Nernstian response of the electrode pair has failed to stabilize during buffering of either buffer 1 or buffer 2	Replace the electrode pair
Calibration Fail	0%	40 to 70%	The new calibration coefficients are ignored and the last known good calibration coefficients are used	Check buffer values and repeat buffering. If the fault persists, replace the electrodes

Table 6.3 pH Calibration Messages (for Sections 6.2.3 and 6.2.4)

6.3 Operation – Redox (ORP) Measurement Mode

Operation in the Redox measurement mode comprises an operating page only. The **Operating Page** is a general use page in which parameters can be viewed but not altered. To alter or program a parameter refer to the programming pages in Section 7.

6.3.1 Operating Page

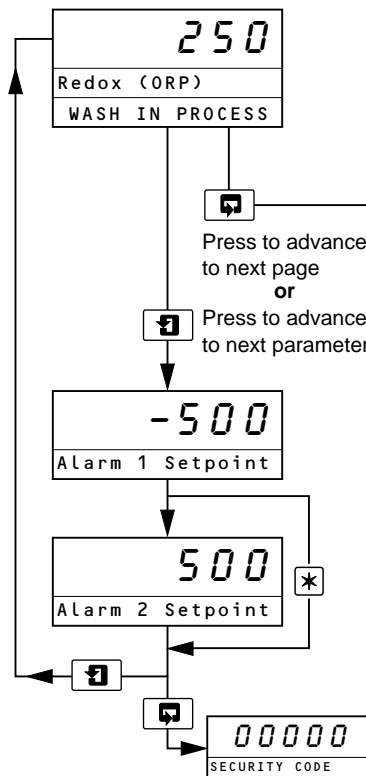

Measured mV

The e.m.f. of the probe is displayed.

If the Water Wash cycle is selected (models 4631 or 4636 only), an alternative message, **WASH IN PROCESS**, is displayed. The Alarm 1 status and the retransmission value are held in their pre-cycle condition for the duration of the wash cycle.

These two keys are used to advance to all subsequent parameters and pages.

Alarm 1 Set Point

The set point value and relay/l.e.d. action are programmable – see Section 7.4, **Set Up Alarms Page**.

Alarm 2 Set Point

The set point value and relay/l.e.d. action are programmable – see Section 7.4, **Set Up Alarms Page**.

 **Note.** This display is bypassed if the **Water Wash** cycle is selected.

Advance to **Access to Secure Parameters**.

7 PROGRAMMING

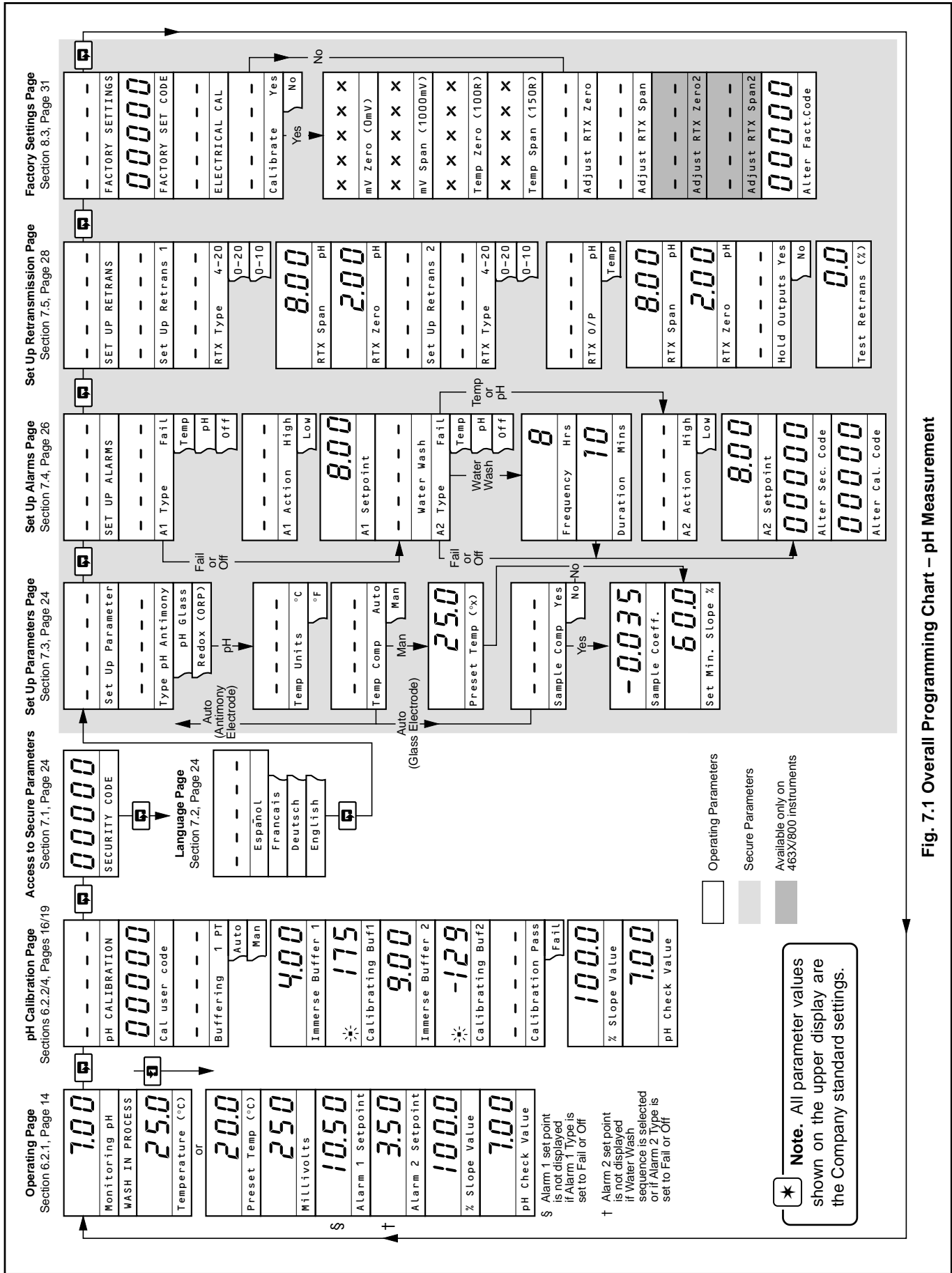

Fig. 7.1 Overall Programming Chart – pH Measurement

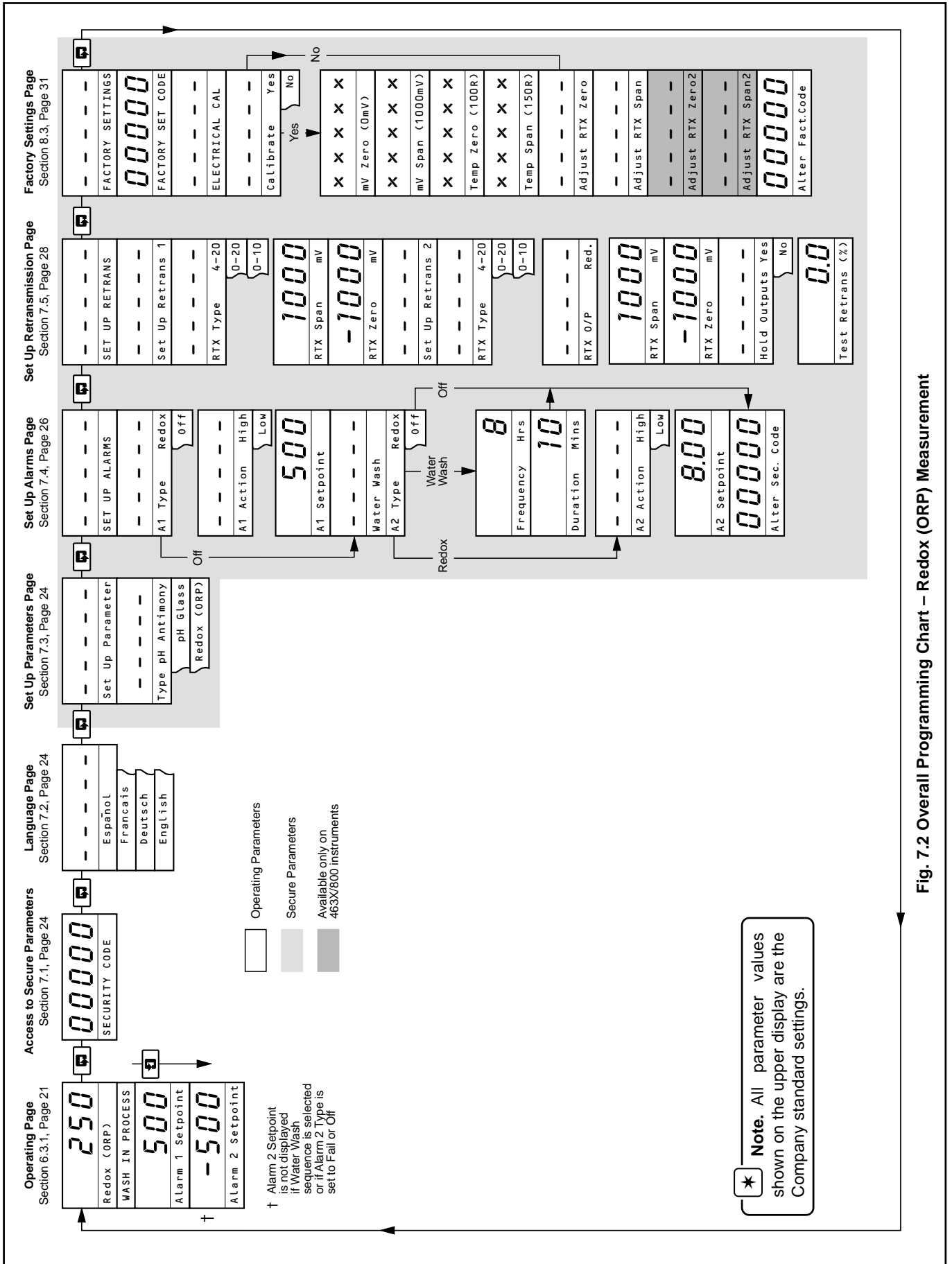

Fig. 7.2 Overall Programming Chart – Redox (ORP) Measurement

...7 PROGRAMMING

7.1 Access to Secure Parameters

00000
SECURITY CODE



Security Code

Enter the required code number, between 00000 and 19999, to gain access to the secure parameters. If an incorrect value is entered, access to subsequent programming pages is prevented and the display reverts to the **Operating Page**.



Español

Advance to **Language Page**.

7.2 Language Page

Español
Français
Deutsch
English



Language Page

Select the language to be displayed on all subsequent pages.



SET UP PARAMETER

Advance to **Set Up Parameters Page**.

7.3 Set Up Parameters Page

SET UP PARAMETER

– press to advance to next parameter

or

– press to advance to next page.

These two keys are used to advance to all subsequent parameters and pages. If a parameter is changed it is automatically stored on operation of either key.

Type pH Antimony
pH Glass
Redox (ORP)



Probe Type

Select pH Antimony/pH Glass for pH display or Redox (ORP) for millivolt display.

Select the required probe type.

Redox

pH

Continued on next page.

...7.3 Set Up Parameters Page

Continued from previous page.

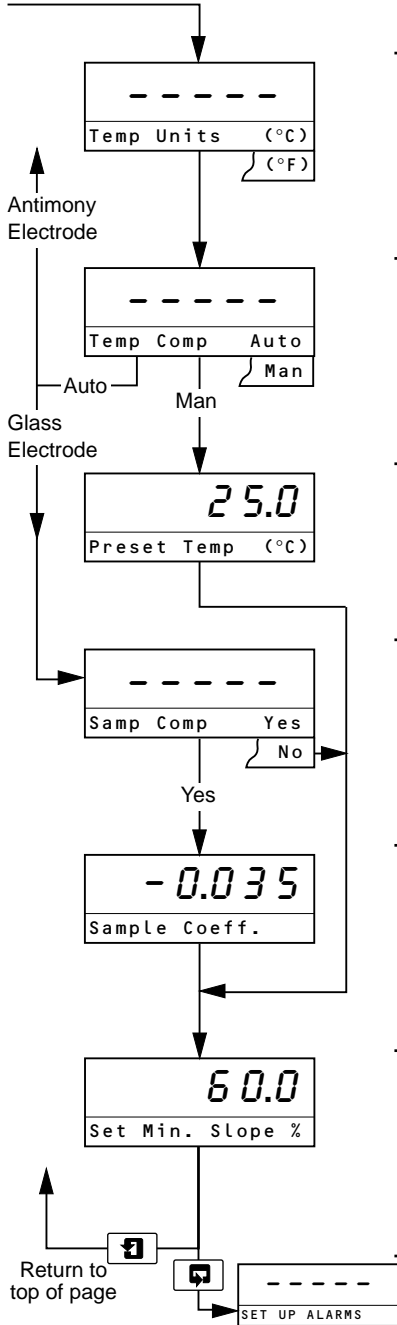

Temperature Units:

can be displayed as either degrees Celsius or Fahrenheit.

Select either (°C) or (°F).

Temperature Compensation

If **A u t o** is selected, the instrument automatically compensates for sample temperature fluctuations.

Select either **A u t o** or **M a n**.

Preset Temperature

If **T e m p e r a t u r e C o m p e n s a t i o n** is set to **M a n**, enter the temperature of the sample.

Return to top of page.

Sample Compensation

If **Y e s** is selected, boiler water compensation is enabled.

Select **Y e s** or **N o** as required.

Sample Coefficient

Set the required sample temperature coefficient value, in pH/°C, within the range 0.000 to -0.040 (in -0.001 increments).

***** **Note.** For boiler water applications, set to -0.035.

pH Calibration Minimum Slope Value

Set the required pH calibration minimum slope value, in %, within the range 60.0 to 90.0 (in 0.1 increments).

The fail limit is automatically set to 20% below the minimum slope setting – see Table 6.3 on page 20.

Advance to **Set Up Alarms Page**.

7.4 Set Up Alarms Page

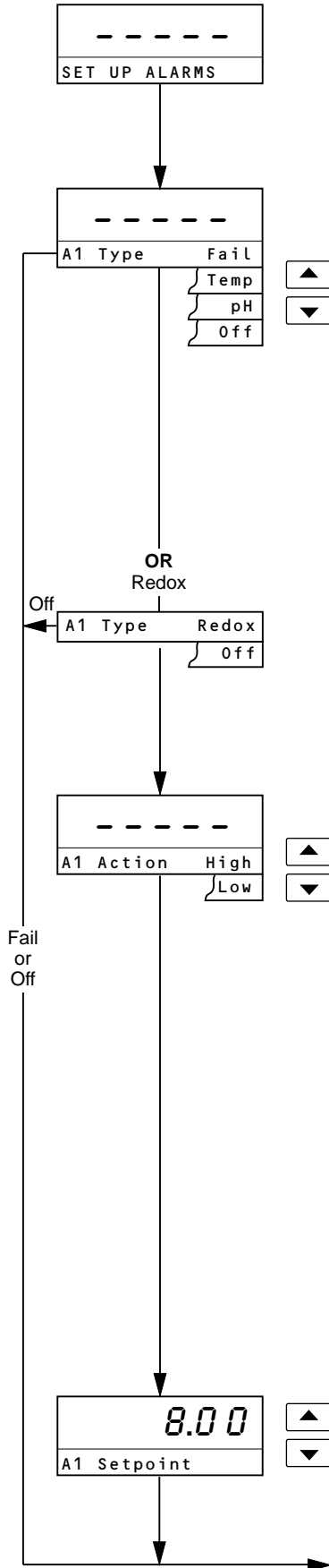

- press to advance to next parameter
or
- press to advance to next page.

These two keys are used to advance to all subsequent parameters and pages. If a parameter is changed it is automatically stored on operation of either key.

Alarm 1 Type

Select the type of alarm required. For **F a i l**, **T e m p** and **p H** alarm types, the alarm l.e.d. is off and the relay energized during normal conditions. In a fail condition, the l.e.d. is on and the relay de-energized.

- F a i l** – The instrument alerts the operator to either a power failure or a condition that causes any of the error messages listed in Table 9.1, page 33 to be displayed.
- T e m p** – The instrument alerts the operator if the temperature of the process fluid exceeds or drops below the value set in the **Alarm 1 Set Point** parameter, depending on the type of **Alarm Action** selected below.
- p H** – The instrument alerts the operator if the pH of the process fluid exceeds or drops below the value set in the **Alarm 1 Set Point** parameter, depending on the type of **Alarm Action** selected below.
- O f f** – If selected, no alarms are set and the alarm l.e.d. is off and the relay de-energized at all times.

Note. If **Probe Type** has been set to **R e d o x** (ORP) in the **Set Up Parameters Page**, only **R e d o x** and **O f f** alarm types are available.

R e d o x – The instrument alerts the operator if the Oxidization Reduction Potential (ORP) of the process fluid exceeds or drops below the value set in the **Alarm 1 Set Point** parameter, depending on the type of **Alarm Action** selected below.

Alarm 1 Action

For '**Fail-safe**' alarm operation the relay's alarm state must be the same as the power-down state, i.e. the relay is de-energized.

For **H i g h** alarm operation the relay must be energized below the alarm set point.

For **L o w** alarm operation the relay must be energized above the alarm set point.

The alarm l.e.d.s are illuminated in the alarm condition.

Select the required alarm 1 action from the following table:

Alarm Action	LED Condition for Input Above Set Point	LED Condition for Input Below Set Point	Relay Condition for Input Above Set Point	Relay Condition for Input Below Set Point
High	ON	OFF	De-energized	Energized
Low	OFF	ON	Energized	De-energized

The set point band is defined as the actual value of the set point plus or minus the hysteresis value. The hysteresis value is $\pm 1\%$ of the Alarm 1 Set Point. Alarm action occurs if the input value is above or below the set point band. If the input moves within the set point band, the last alarm action is maintained.

Alarm 1 Set Point

The alarm 1 set point can be set to any value within the input range being displayed. The set point value is subject to hysteresis as detailed above.

Set the alarm set point to the required value.

Continued on next page.

...7.4 Set Up Alarms Page

Continued from previous page

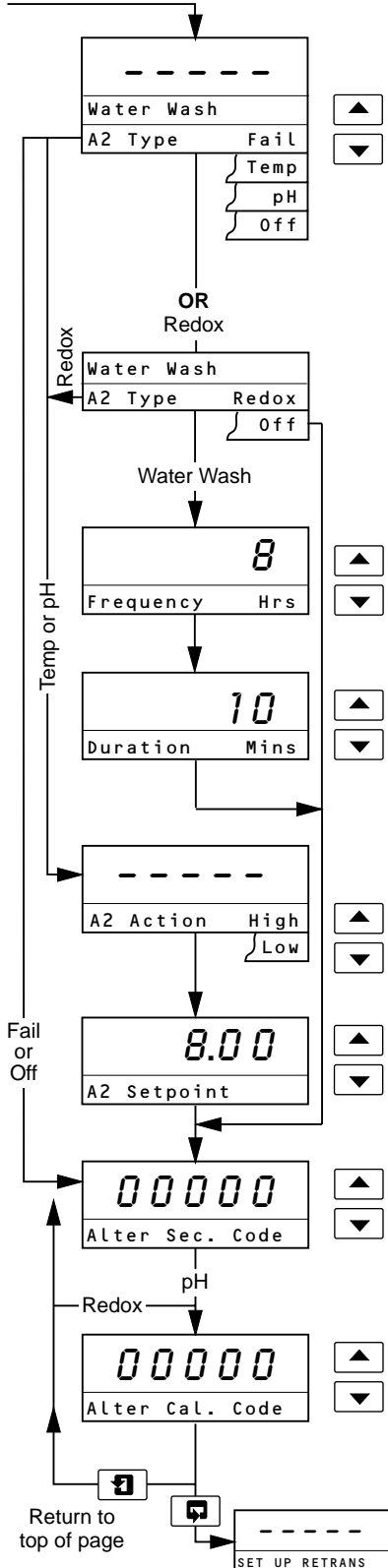

Water Wash (4631/4636 only) /Alarm 2 Action

To select the Water Wash cycle press the key until **Water Wash** is displayed.

To select Alarm 2 Type, press the key until **A2 Type** is displayed, then repeat as for **Alarm 1 Type**, previous page.

Wash Frequency

Water wash frequency can be set in 15 minute increments to between 15 and 60 minutes, then in 1 hour increments to between 1 and 24 hours.

Wash Duration

Water wash duration can be set in 15 second increments to between 15 and 60 seconds, then in 1 minute increments to between 1 and 10 minutes.

Alarm 2 Action

Repeat as for **Alarm 1 Action**.

Alarm 2 Set Point

Repeat as for **Alarm 1 Set Point**.

Alter Secure Parameters Security Code

Set the secure parameters security code to a value between 00000 and 19999.

Alter pH Calibration Security Code



Set the pH calibration security code to a value between 00000 and 19999.

Advance to **Set Up Retransmission Page**.

...7 PROGRAMMING

7.5 Set Up Retransmission Page

SET UP RETRANS

 – press to advance to next parameter
or
 – press to advance to next page.

These two keys are used to advance to all subsequent parameters and pages. If a parameter is changed it is automatically stored on operation of either key.

Set Up Retrans 1

Retransmission 1 Page Header

RTX Type 4-20
 0-20
 0-10

Retransmission 1 Output Current Range

The retransmission 1 output can be selected from three mA current ranges to ensure compatibility with the peripheral device connected.

Select the current range required for retransmission 1 output.

8.00
RTX Span (Units)

Retransmission 1 Span

Set the required retransmission 1 span output. This is adjustable to between 2.00 and 14.00 (pH) or –850 and 1000mV (Redox).

2.00
RTX Zero (Units)

Retransmission 1 Zero

Set the required retransmission 1 zero output. This is adjustable to between 0.00 and 12.00 (pH) or –1000 and 850mV (Redox).

 **Note.** The minimum range is any 2pH units within the 0.00 to 14.00 range (pH) or 150mV within the –1000 to 1000mV range (Redox).

Continued on next page.

...7.5 Set Up Retransmission Page

Continued from previous page.

SET UP RETRANS 2

Retransmission 2 Page header

***** **Note.** The second retransmission output is available only on 4630/800, 4631/800, 4635/800 and 4636/800 instruments.

RTX Type 4-20
0-20
0-10

Retransmission 2 Output Current Range

The retransmission 2 output can be selected from three mA current ranges to ensure compatibility with the peripheral device connected.

Select the current range required for retransmission 2 output.

RTX O/P pH
Red.
Temp

Retransmission 2 Output Assignment

The retransmission 2 output can be assigned to monitor Temperature and either pH or Redox, dependent upon the **Probe Type** selected – see Section 7.3, **Set Up Parameters Page**.

***** **Note.** The pH and Temp options are not available when **Probe Type** is set to Redox (ORP).

***** **Note.** The Temp option is not available when **Probe Type** is set to pH Antimony or pH Glass and manual temperature compensation is selected – see Section 7.3, **Set Up Parameters Page**.

Select the retransmission 2 output assignment required.

8.00
RTX Span (Units)

Retransmission 2 Span

Set the required retransmission 2 span output. This is adjustable to between 2.00 and 14.00 (pH), –850 and 1000mV (Redox) or either 10.0 and 150.0°C or 50.0 and 302.0°F (Temp).

2.00
RTX Zero (Units)

Retransmission 2 Zero

Set the required retransmission 2 zero output. This is adjustable to between 0.00 and 14.00 (pH), –1000 and 850mV (Redox) or either –10.0 and 130.0°C or 14.0 and 266.0°F (Temp).

***** **Note.** The minimum range is any 2pH units within the 0.00 to 14.00pH range, 150mV within the –1000 to 1000mV range (Redox) or either 20°C within the –10.0 to 130.0°C range or 36°F within the 14.0 to 266.0°F range (Temp).

Hold Outputs Yes
No

Hold Outputs

The retransmission and alarm outputs can be held to prevent inadvertant operation during pH calibration. Select **Yes** or **No**.

0.0
Test Retrains (%)

Test Retransmission Output

The instrument automatically transmits a test signal of 0, 25, 50, 75 or 100% of the retransmission range selected above. The % test signal selected is shown on the upper display.

Example – for a selected range of 0 to 20mA and 50% retransmission test signal, 10mA is transmitted.

Select the required retransmission test signal.

Return to top of page

FACTORY SETTINGS

Advance to **Factory Settings Page**.

8 CALIBRATION

* **Note.** The instrument is calibrated by the Company prior to despatch and recalibration should be carried out **only** if the instrument's accuracy is suspect **and** suitably calibrated test equipment is available.

8.1 Equipment Required

- Millivolt source (pH or Redox input simulator, if required) –1000 to +1000mV.
- Decade resistance box (PT100 input simulator): 0 to 1k Ω (in increments of 0.01 Ω).
- Digital milliammeter (current output measurement): 0 to 20mA.

* **Note.** Resistance boxes have an inherent residual resistance which may range from a few m Ω up to 1 Ω . This value must be taken into account when simulating input levels, as should the overall tolerance of the resistors within the boxes.

8.2 Preparation

- Switch off the supply and disconnect the electrode system, temperature compensator and current output from the instrument's terminal blocks – see Fig. 4.4 (page 9) or Fig. 4.5 (page 10).
- Wall-mounted Instruments (Fig 8.1A):**
 - Link terminals 6 & 7.
 - Connect the millivolt source to terminals 2 & 4 to simulate the pH or Redox input. Connect the millivolt source earth to the Case Earth Stud.
 - Connect the 0 to 1k Ω decade resistance box to terminals 5 & 7 to simulate the PT100.
 - Connect the milliammeter to the retransmission output terminals – see Fig. 4.4 (page 9).
- Panel-mounted Instruments (Fig 8.1B):**
 - Link terminals 6 & 7.
 - Connect the millivolt source to terminals 9 & 11 to simulate the pH or Redox input. Connect the millivolt source earth to the Case Earth Stud.
 - Connect the 0 to 1k Ω decade resistance box to terminals 6 & 8 to simulate the PT100.
 - Connect the milliammeter to the retransmission output terminals – see Fig. 4.5 (page 12).
- Switch on the supply and allow ten minutes for the circuits to stabilize.
- Select the **FACTORY SETTINGS** page and carry out Section 8.3.

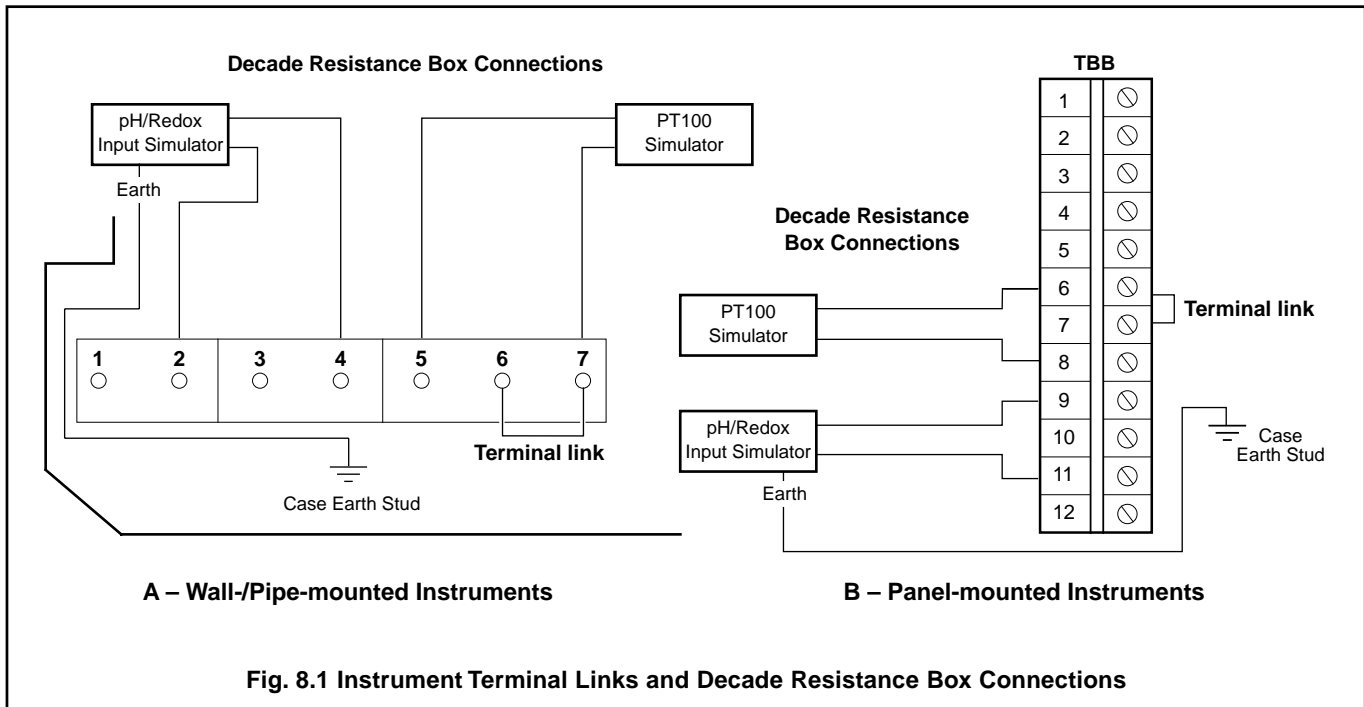
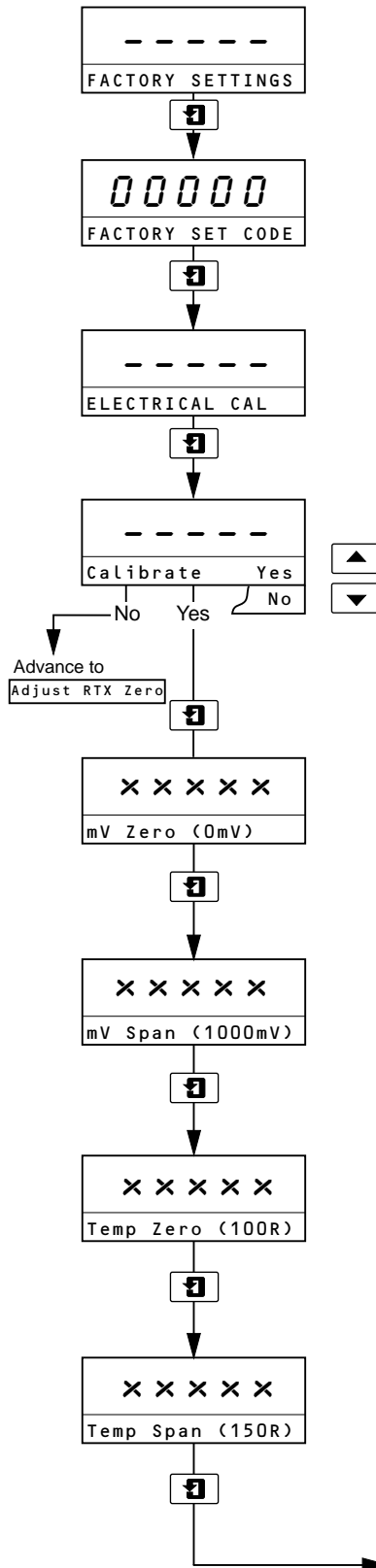

Fig. 8.1 Instrument Terminal Links and Decade Resistance Box Connections

8.3 Factory Settings Page

When carrying out the electrical calibration procedure, the actual values denoted by $\times \times \times \times$ are unimportant and are used only to determine display reading stability.



Factory Settings Access Code

Enter the required code number, between 00000 and 19999, to gain access to the factory settings. If an incorrect value is entered, access to subsequent parameters is prevented and the display reverts to the top of the **Factory Settings Page**.

Electrical Calibration

Select Yes to access the electrical calibration sequence. Select No to advance to **Adjust Retransmission Zero** – see next page.



Caution. Do not select Yes unless instrument calibration is required.

Advance to next parameter.

Millivolt Zero

Set the millivolt source to 0mV and allow the instrument display to stabilize.

Advance to next parameter.

Millivolt Span

Set the millivolt source to +1000mV and allow the instrument display to stabilize.

Advance to next parameter.

Calibrate Temperature Zero

Set the temperature simulator resistance box to 100Ω and allow the instrument display to stabilize.

Advance to next parameter.

Calibrate Temperature Span

Set the temperature simulator resistance box to 150Ω and allow the instrument display to stabilize.

Advance to next parameter.

Continued on next page.

...8 CALIBRATION

...8.3 Factory Settings Page

Continued from previous page.

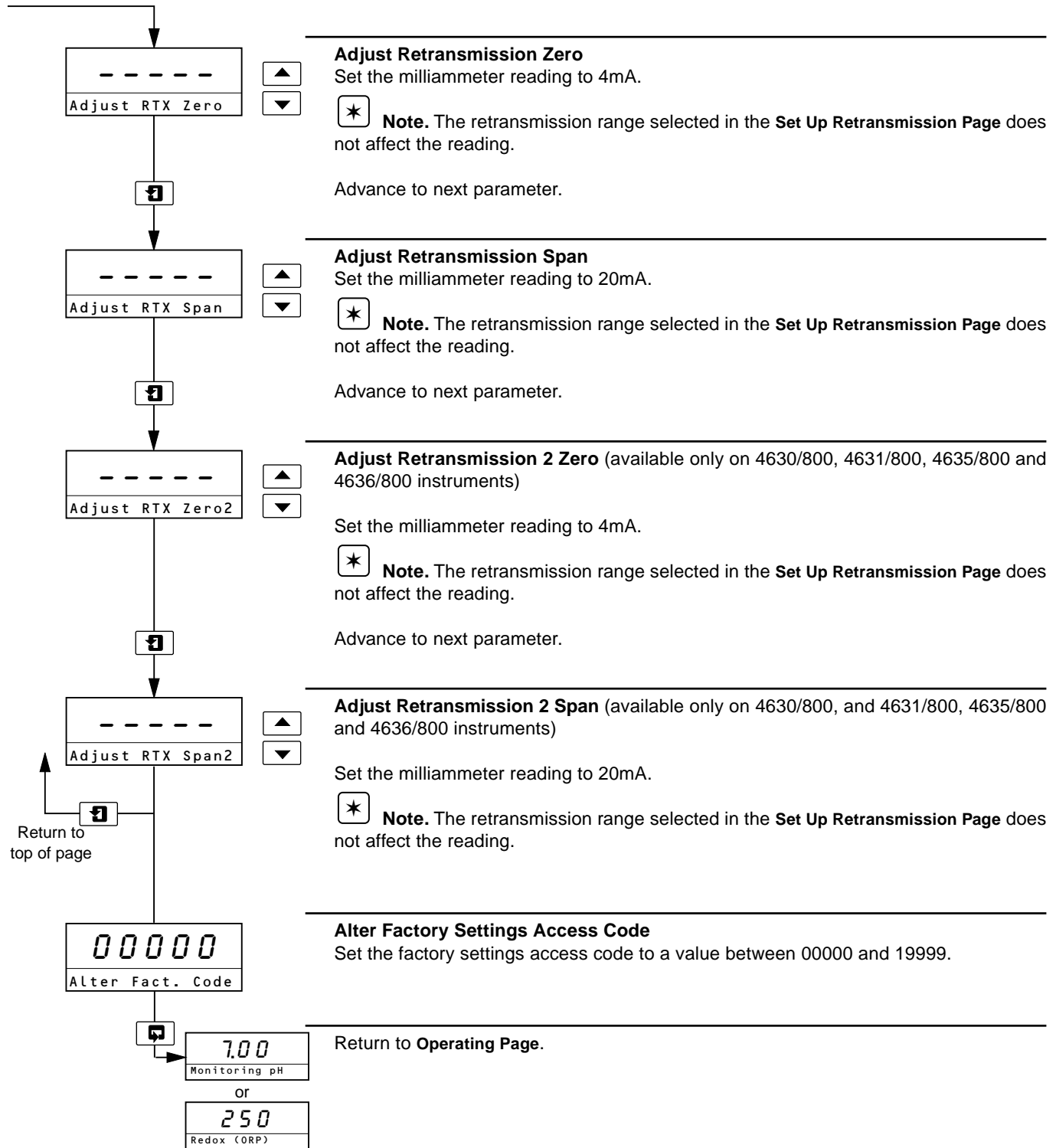

9 SIMPLE FAULT FINDING

9.1 Error Messages

If erroneous or unexpected results are obtained the fault may be indicated by an error message – see Table 9.1. However some faults may cause problems with instrument calibration when using buffer solutions or give discrepancies when compared with independent laboratory measurements.

Error Message	Possible Cause
FAULTY PT100	Temperature compensator/ associated connections are either open or short circuit.
pH/INPUT O/C	The voltage on the open circuit reference electrode/electrodes is outside the input range of $\pm 1000\text{mV}$.
LAST CAL. FAILED	Message displayed only on power-up. The last pH calibration, carried out before power-down, failed.*
NV MEMORY ERROR	The contents of the non-volatile memory have not been read correctly during power up.**

* This message applies to the last pH calibration carried out prior to power-down and is not an indication of incorrect calibration.

** To rectify the fault, switch off, wait 10 seconds and switch on again. If the fault persists, contact the Company.

Table 9.1 Error Messages

9.2 Calibration Fail Message or no Response to pH/Redox Changes

The majority of problems are associated with the electrodes and cabling. Replace the electrodes as an initial check – refer to the appropriate instruction manual. It is also important that all program parameters have been entered correctly and have not been altered inadvertently – see Section 7.

If the above checks do not resolve the fault:

- a) Check that the instrument responds to a millivolt input. Connect a pH simulator, such as Model 2410, to the transmitter input; +ve to glass and –ve to reference – see Section 4.3 or 4.4. Select the **Set Up Parameters Page** and set the **Probe Type** to **Redox (ORP)** – see page 24. Check that the transmitter displays the correct values as set on the simulator.



Note. A normal laboratory mV source is not suitable for use as a pH simulator.

Failure to respond to the input indicates a fault with the transmitter which must be returned to the Company for repair. Correct response, but with incorrect readings, usually indicates a calibration problem. Recalibrate the transmitter as detailed in Section 8.

- b) Use the simulator to carry out an impedance check on the transmitter, i.e. glass to reference, glass to earth and reference to earth – refer to simulator manual.

If the transmitter fails this test, check for moisture within the transmitter and in particular the terminal compartment. It is vital that all evidence of moisture is removed with the use of a hot air drier.

- c) Reconnect the electrode cable and connect the simulator to the electrode end of the cable. Repeat the procedures a) and b) above. If the transmitter fails test b), check for moisture around the connections and check that the insulation on the inner co-axial conductor is clean and that the graphite layer has been removed.

9.3 Checking the Temperature Input

Check that the instrument responds to a temperature input. Disconnect the PT100 leads and connect a suitable resistance box directly to the transmitter inputs – see Section 4.3 or 4.4. Check that the transmitter displays the correct values as set on the resistance box – see Table 9.2.

Incorrect readings usually indicate an electrical calibration problem – re-calibrate the instrument as detailed in Section 8.3.

Temperature °C	Input Resistance (Ω)
0	100.00
10	103.90
20	107.79
25	109.73
30	111.67
40	115.54
50	119.40
60	123.24
70	127.07
80	130.89
90	134.70
100	138.50
130.5	150.00

Table 9.2 Temperature Readings for Resistance Inputs

10 SPECIFICATION

Display

Measured value:

5-digit x 7-segment back-lit I.c.d.

Information:

16-character, single line, dot matrix back-lit I.c.d.

Ranges:

0 to 14pH, -1000 to 1000mV.

Minimum range:

Any 5pH units or 300mV.

Resolution:

0.01pH, 1mV.

Accuracy:

±1% f.s.d.

Linearity:

±0.2%f.s.d.

Temperature compensation:

-10 to 110°C (14 to 230°F) manual or automatic using Pt100 resistance thermometer.

Set Points and Relays

No. of set points:

Two.

Set point adjustment:

Programmable.

Set point hysteresis:

±1% of f.s.d. (fixed)

Local set point annunciation:

Red I.e.d.

No. of relays:

Two.

Relay contacts:

Single pole changeover.

Rating:	250V a.c.	250V d.c. max.
	3A a.c.	3A d.c. max.

Loading:		
(non-inductive)	750VA	30W max.
(inductive)	75VA	3W max.

Insulation, contacts to earth:

2kV r.m.s.

Retransmission

No. of retransmission signals:

One, fully isolated – standard.

Two, fully isolated – optional.

Output current:

0 to 10, 0 to 20 or 4 to 20mA programmable.

Accuracy:

±0.25% f.s.d. or ±0.5% reading.

Output ranges:

Retransmission 1:

Programmable	–	pH or Redox(ORP)
pH	–	as per retransmission 1
Redox(ORP)	–	-1000 to 1000mV, min. span 150mV

Retransmission 2 (optional):

Programmable	–	pH, Redox(ORP) or Temperature
pH	–	as per retransmission 1
Redox(ORP)	–	-1000 to 1000mV, min. span 150mV
Temperature	–	-10 to 150°C (32 to 302°F), min. span 20°C (36°F)

Resolution:

0.1% of f.s.d.

Maximum load resistance:

750Ω (20mA max.).

Serial communication:

RS422/RS485 (optional).

Power Supply

Voltage requirements:

100 to 130V or
200V to 260V, 50/60Hz.

Power Consumption:

< 6VA.

Error due to power supply variations:

less than 2% for +6% -20% variation from nominal supply voltage.

Insulation, mains to earth:

2kV r.m.s.

Environmental Data

Operating temperature limits:

-20 to 55°C (-4 to 130°F).

Storage temperature limits:

-25 to 70°C (-13 to 158°F).

Operating humidity limits:

Up to 95%RH non-condensing.

Mechanical Data

Mounting:

Model 4630/31 wall-mounting,
Model 4635/36 panel-mounting.

Protection:

Model 4630/31 – IP66, Model 4635/36 – IP66 front.

Overall dimensions:

Model 4630/31 – 160 x 250 x 68mm
(6.3 x 9.84 x 2.68in.) – see Fig. 3.2.

Model 4635/36 – 96 x 96 x 191mm
(3.78 x 3.78 x 7.52in.) – see Fig. 3.4.

Panel cut-out:

92^{+0.8}_{-0.0} x 92^{+0.8}_{-0.0} mm (3.62^{+0.03}_{-0.00} x 3.62^{+0.03}_{-0.00} in.)

Weight:

Model 4630/31 – 2kg (4½ lb).

Model 4635/36 – 1.5kg (3¼ lb).

NOTES

PRODUCTS & CUSTOMER SUPPORT

Products

Automation Systems

- *for the following industries:*
 - Chemical & Pharmaceutical
 - Food & Beverage
 - Manufacturing
 - Metals and Minerals
 - Oil, Gas & Petrochemical
 - Pulp and Paper

Drives and Motors

- *AC and DC Drives, AC and DC Machines, AC motors to 1kV*
- *Drive systems*
- *Force Measurement*
- *Servo Drives*

Controllers & Recorders

- *Single and Multi-loop Controllers*
- *Circular Chart, Strip Chart and Paperless Recorders*
- *Paperless Recorders*
- *Process Indicators*

Flexible Automation

- *Industrial Robots and Robot Systems*

Flow Measurement

- *Electromagnetic Flowmeters*
- *Mass Flow Meters*
- *Turbine Flowmeters*
- *Flow Elements*

Marine Systems & Turbochargers

- *Electrical Systems*
- *Marine Equipment*
- *Offshore Retrofit and Refurbishment*

Process Analytics

- *Process Gas Analysis*
- *Systems Integration*

Transmitters

- *Pressure*
- *Temperature*
- *Level*
- *Interface Modules*

Valves, Actuators and Positioners

- *Control Valves*
- *Actuators*
- *Positioners*

Water, Gas & Industrial Analytics Instrumentation

- *pH, conductivity, and dissolved oxygen transmitters and sensors*
- *ammonia, nitrate, phosphate, silica, sodium, chloride, fluoride, dissolved oxygen and hydrazine analyzers.*
- *Zirconia oxygen analyzers, katharometers, hydrogen purity and purge-gas monitors, thermal conductivity.*

Customer Support

We provide a comprehensive after sales service via a Worldwide Service Organization. Contact one of the following offices for details on your nearest Service and Repair Centre.

United Kingdom

ABB Limited
Tel: +44 (0)1453 826661
Fax: +44 (0)1453 829671

United States of America

ABB Inc.
Tel: +1 (0) 755 883 4366
Fax: +1 (0) 755 883 4373

Client Warranty

Prior to installation, the equipment referred to in this manual must be stored in a clean, dry environment, in accordance with the Company's published specification.

Periodic checks must be made on the equipment's condition. In the event of a failure under warranty, the following documentation must be provided as substantiation:

1. A listing evidencing process operation and alarm logs at time of failure.
2. Copies of all storage, installation, operating and maintenance records relating to the alleged faulty unit.

ABB has Sales & Customer Support
expertise in over 100 countries worldwide

www.abb.com

The Company's policy is one of continuous product
improvement and the right is reserved to modify the
information contained herein without notice.

Printed in UK (03.04)

© ABB 2004



ABB Limited
Oldends Lane, Stonehouse
Gloucestershire
GL10 3TA
UK
Tel: +44 (0)1453 826 661
Fax: +44 (0)1453 829671

ABB Inc.
2175 Lockheed Way
Carson City
NV 89706
USA
Tel: +1 (0) 775 883 4366
Fax: +1 (0) 775 883 4373