

# Gas Analyzer Systems for Hydrogen-cooled Alternators

AK102 and AK103



# ABB

## The Company

We are an established world force in the design and manufacture of instrumentation for industrial process control, flow measurement, gas and liquid analysis and environmental applications.

As a part of ABB, a world leader in process automation technology, we offer customers application expertise, service and support worldwide.

We are committed to teamwork, high quality manufacturing, advanced technology and unrivalled service and support.

The quality, accuracy and performance of the Company's products result from over 100 years experience, combined with a continuous program of innovative design and development to incorporate the latest technology.

The UKAS Calibration Laboratory No. 0255 is just one of the ten flow calibration plants operated by the Company and is indicative of our dedication to quality and accuracy.

EN ISO 9001:2000



Cert. No. Q 05907

EN 29001 (ISO 9001)



Lenno, Italy – Cert. No. 9/90A

Stonehouse, U.K.



0255

## Electrical Safety

This instrument complies with the requirements of CEI/IEC 61010-1:2001-2 "Safety requirements for electrical equipment for measurement, control, and laboratory use". If the instrument is used in a manner NOT specified by the Company, the protection provided by the instrument may be impaired.

## Symbols

One or more of the following symbols may appear on the instrument labelling:

	<b>Warning</b> – Refer to the manual for instructions		Direct current supply only
	<b>Caution</b> – Risk of electric shock		Alternating current supply only
	Protective earth (ground) terminal		Both direct and alternating current supply
	Earth (ground) terminal		The equipment is protected through double insulation

Information in this manual is intended only to assist our customers in the efficient operation of our equipment. Use of this manual for any other purpose is specifically prohibited and its contents are not to be reproduced in full or part without prior approval of the Technical Publications Department.

### Health and Safety

To ensure that our products are safe and without risk to health, the following points must be noted:

1. The relevant sections of these instructions must be read carefully before proceeding.
2. Warning labels on containers and packages must be observed.
3. Installation, operation, maintenance and servicing must only be carried out by suitably trained personnel and in accordance with the information given.
4. Normal safety precautions must be taken to avoid the possibility of an accident occurring when operating in conditions of high pressure and/or temperature.
5. Chemicals must be stored away from heat, protected from temperature extremes and powders kept dry. Normal safe handling procedures must be used.
6. When disposing of chemicals ensure that no two chemicals are mixed.

Safety advice concerning the use of the equipment described in this manual or any relevant hazard data sheets (where applicable) may be obtained from the Company address on the back cover, together with servicing and spares information.

# CONTENTS

<b>1</b>	<b>INTRODUCTION</b>	<b>2</b>	<b>9</b>	<b>OPERATION</b>	<b>25</b>
			9.1	Normal	25
			9.1.1	Purging of Hydrogen Coolant Gas	25
			9.1.2	Filling with Hydrogen Coolant Gas	25
			9.2	Range 1 Operating Page	26
			9.3	Range 2 Operating Page	26
			9.4	Range 3 Operating Page	26
<b>2</b>	<b>DESCRIPTION</b>	<b>3</b>	<b>10</b>	<b>PROGRAMMING</b>	<b>28</b>
2.1	Model 6553 Display Unit	3	10.1	Access to Secure Parameters	28
2.1.1	Range Display	3	10.2	Language Page	28
2.2	Model 006540203 or 006548000 Katharometer Analyzer Panel	4	10.3	Set Up Outputs Page	29
2.3	Model 4234 500/4234 501 Power Supply Units (PSU)	4	10.4	Electrical Calibration Page	30
2.4	Remote Indicator/Controllers	4	<b>11</b>	<b>MAINTENANCE</b>	<b>31</b>
<b>3</b>	<b>PREPARATION</b>	<b>5</b>	11.1	General Maintenance	31
3.1	Identification	5	11.1.1	Pressure	31
3.1.1	Model 6553 Display Unit	5	11.1.2	Flow	31
3.1.2	Model 006540 203 or 006548 000 Katharometer Analyzer Panel	5	11.1.3	Leaks	31
3.1.3	Model 4234 Power Supply Unit	6	11.1.4	Vibration	31
3.1.4	AK100 Ordering Information	7	11.1.5	Contamination	31
			11.1.6	Ambient Temperature	31
			11.1.7	Bridge Current	31
<b>4</b>	<b>MECHANICAL INSTALLATION</b>	<b>8</b>	11.2	Diagnostic Tests	31
4.1	Locating and Mounting System Items	8	11.2.1	Checking Output of the PSU	31
4.1.1	Model 6553 Display Unit	8	11.2.2	Checking Integrity of Zener Diode Safety Barrier Devices	31
4.1.2	Katharometer Analyzer Panel	9	11.2.3	Checking the Katharometer Output	31
4.1.3	Model 4234 Power Supply Unit	10	11.3	Routine Maintenance	31
4.1.4	Cubicle Mounted System	11	11.3.1	Hydrogen Katharometer Calibration	31
4.2	Sample Gas Interconnections	12	11.3.2	Purge Gas Katharometer Calibration	31
			11.3.3	Changing Desiccant in Drying Chamber	32
<b>5</b>	<b>ELECTRICAL INSTALLATION</b>	<b>13</b>	11.4	Repair Maintenance	32
5.1	Electrical Interconnections	13	11.4.1	Removing Liquid from Katharometer Measurement Block	32
5.1.1	Model 6553 Display Unit	14	11.4.2	Removal/Replacement of an Indicator Unit	33
5.1.2	Model 006540 203 and 0065480 00 Katharometer Analyzer Panel	17	11.4.3	Error Messages	33
5.1.3	Model 4234 Power Supply Unit	18	<b>12</b>	<b>SPARE PARTS LIST</b>	<b>33</b>
5.2	Intrinsically Safe Requirements	19	12.1	Consumables	33
5.2.1	Cable Requirements	19	12.2	Routine Maintenance Parts	33
5.2.2	Recommended Cables	19	12.3	Repair Maintenance Parts	33
5.2.3	Installing Remote Ancillary Items	19	<b>13</b>	<b>SPECIFICATION</b>	<b>34</b>
5.2.4	Full Intrinsically Safe Requirements	19			
<b>6</b>	<b>SETTING UP</b>	<b>20</b>			
6.1	Katharometer Analyzer Panel – Filling the Drying Chamber	20			
6.2	Setting Sample Flow	20			
6.3	Electrical Checks	21			
6.3.1	Power Supply Unit Output	21			
6.3.2	Zener Diode Safety Barrier Devices	21			
6.3.3	Checking System Earth	21			
<b>7</b>	<b>CONTROLS &amp; DISPLAYS</b>	<b>22</b>			
7.1	Displays	22			
7.2	Switch Familiarization	22			
<b>8</b>	<b>START-UP</b>	<b>23</b>			
8.1	Instrument Start-Up	23			
8.2	Alarm Set Point	23			
8.2.1	Type of Alarm Action	23			
8.2.2	Hydrogen alarm Set Point	23			
8.3	Electrical Calibration	23			
8.4	Gas Calibration	24			
8.4.1	Introduction	24			
8.4.2	Gas Range Calibration	24			

# 1 INTRODUCTION

**Note.** CO<sub>2</sub> is referred to throughout this manual as the purge gas. However, other gases such as Argon or Nitrogen may be used instead.

**Caution.** This operating manual applies only to those systems that have been designed and constructed to the standards specified in the schedules of the ATEX certificates listed. The separate units to which these certificates apply are clearly identifiable by model numbers and the data on the identification and ATEX certification labels fixed to them. Other combinations of similar equipment built to any earlier specifications are not covered by BASEEFA certificate number BAS Ex 01E2044. This is particularly important where new replacement units are to be incorporated into existing installations covered by any earlier certification standards. If in any doubt about the installation of particular combinations of certified equipment, contact the Company for advice before proceeding.

It is essential that units are installed strictly in accordance with the appropriate standards for electrical equipment for use in flammable atmospheres. Any deviation from the specified installation conditions, or any unauthorized repairs or adjustments can invalidate the safety assurances given by the certification of the unit.

The ultimate responsibility for any particular installation lies with the installing user/contractor.

This manual gives the installation, operating and maintenance information for the Company's range of Models AK102 and AK103 Intrinsically Safe Gas Analyzer Systems, normally used with hydrogen cooled electrical power generators.

A complete AK100 Analyzer system uses a combination of three different units. Each unit is certified independently for use as part of an intrinsically safe system to meet the standards of the ATEX directive 9/94/EC for use in association with Group IIC (hydrogen) hazardous atmospheres in accordance with the following standards:

EN 50014 : 1997 + Amendments 1 & 2 EN 50020 : 1994	006539 & 006548 Katharometer Units 4234 500/501 Power Supply Unit 6553 Display Unit
EN 50284 : 1999	006539 & 006548 Katharometer Units
EN 50039 : 1980	System

The different units of the system are:

- 1) Model 6553 Display Unit, available in several variants. The inputs to the unit are certified to code [EEx ia] IIC T<sub>amb</sub> = -20 to 40°C under BAS 01 ATEX 7043 certificate with the unit installed in the **safe** area only.
- 2) Model 006539-960K (or J) and 006548-001 Katharometer Units that form part of an intrinsically safe Model 006540-203 and 006548-000 Katharometer Analyzer Panel. These units are certified to code EEx ia IIC T<sub>4</sub> T<sub>amb</sub> = -20 to 55°C under BAS 01 ATEX 1042 certificate for installation in the **hazardous** area (ZONE 0).
- 3) Model 4234 500 and 4234 501 constant current Power Supply Unit provides the supply for one Katharometer Unit. These power supply units have their output certified to code [EEx ia] IIC T<sub>amb</sub> = -20 to 55°C under BAS 01 ATEX 7041 certificate for installation in the **safe** area only.

If further information or assistance is required contact our specialist staff at one of the addresses shown on the back cover of this manual. Specialist training courses can also be arranged at our Training Centre.

## 2 DESCRIPTION

All the various system options comprise one or more of the following units with the further option of fitting the display and power supply units in a cubicle.

**Note.** CO<sub>2</sub> is referred to throughout this manual as the purge gas. However, other gases such as Argon or Nitrogen may be used instead.

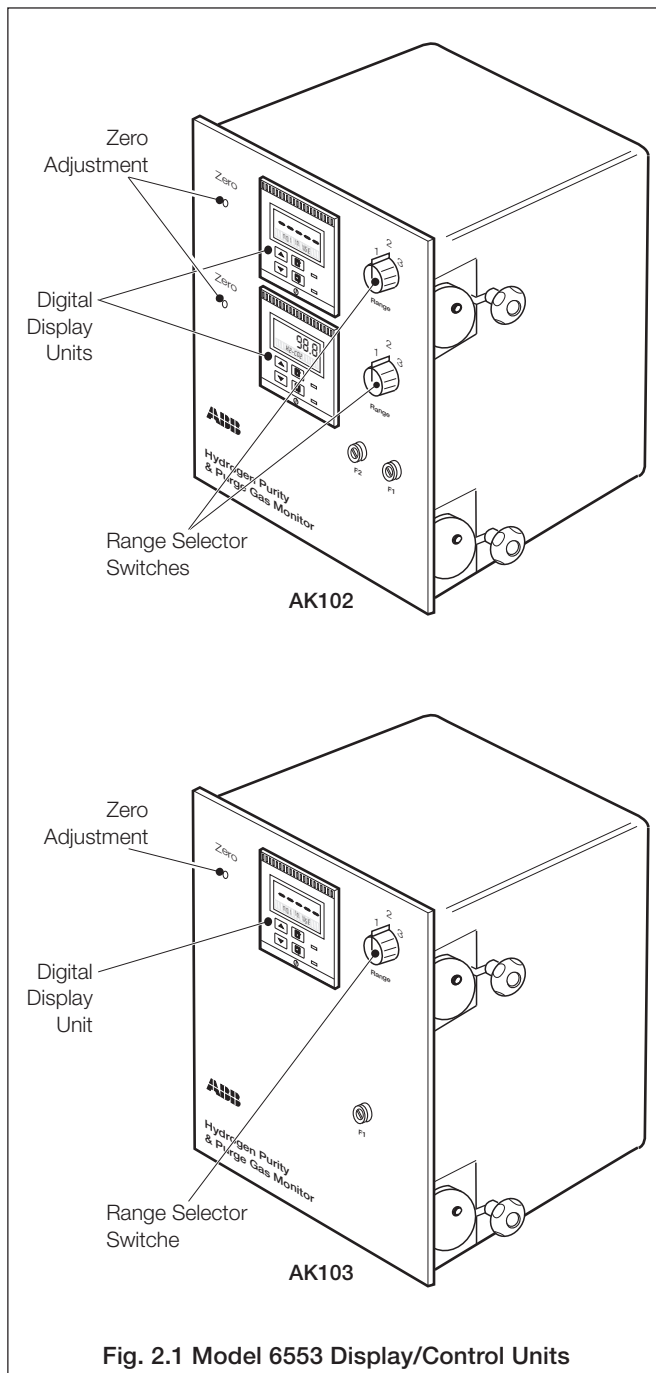

Fig. 2.1 Model 6553 Display/Control Units

### 2.1 Model 6553 Display Unit

The display unit must be mounted in a **safe** area and is suitable for panel mounting or installation into a control cubicle. The unit houses one or two Model 4689 digital display units, each equipped with a range selector switch and protected access for zero adjustment – see Fig. 2.1.

The AK102 version is a dual 3-range instrument, designed to provide 100% redundancy.

The AK103 version is a single 3-range instrument.

#### 2.1.1 Range Display

A selector switch for each display provides independent parameter selection as follows:

- Position (1) **Percentage of Hydrogen in Air by volume.**  
This is the hydrogen purity measurement of the coolant gas during normal operation of the system. The display covers a range of 85 to 100% or 80 to 100% hydrogen in air depending on the range selected. An alarm output and a retransmission signal (4 to 20mA) are provided for this switch position only.
- Position (2) **Percentage of Hydrogen in CO<sub>2</sub>/Argon by volume.**  
This range is for use in hydrogen filling or purging operation. Alarm and retransmission signals are inhibited in this switch position.
- Position (3) **Percentage of Air in CO<sub>2</sub>/Argon by volume.**  
This range is for use in carbon dioxide (or argon) filling or purging operations. Alarm and retransmission signals are inhibited in this switch position.

A further option of providing remote indication of range selector switch may be available, depending on the number of alarms specified.

The 4689 Display Units provide software specific to the katharometer systems with relay action of the alarms fixed as 'fail safe'. All user-programmable data can be protected from unauthorized alteration by a programmable 5-digit security number.

The zero adjustments on the front panel enable remote zeroing of the katharometers mounted in the **hazardous** area. The adjustment access for a particular display is adjacent to the display and at the same level.

The 4689 has a protective case that can be removed for access to the interior without removing the whole unit from the control panel.

The 4689 contains encapsulated zener diode safety barrier devices to limit the electrical energy that can be supplied from the instrument circuits into the **hazardous** area. These devices are located below the display units, on a rail that **MUST** be earthed (grounded). A metal screening arrangement segregates the connections made to equipment in the **hazardous** area. The unit is protected on the mains input side by two fuses, one for each circuit, accessible from the front of the panel.

## ...2 DESCRIPTION

### 2.2 Model 006540203 or 006548000 Katharometer Analyzer Panel – Fig. 2.2

Each panel comprises a metering valve, a drying chamber, a thermally lagged katharometer (Model 006539 or 006548) and a flowmeter. These items are mounted on a flat panel suitable for fixing to a vertical surface close to the sample point. The katharometers are calibrated for the hydrogen purity measurement as well as hydrogen in carbon dioxide and air in carbon dioxide.

Each katharometer assembly incorporates a Wheatstone Bridge comprising fine, glass-coated platinum filaments. One pair of parallel arms is sealed in the reference gas and the other pair exposed to the sample gas.

When the intrinsically safe stabilized current from the 4234 power supply unit (Model 4234 500 or 4234 501) is passed through this bridge, the temperature of the platinum filaments rises to a point of thermal equilibrium. Under conditions that are arranged to give minimum radiation and convection heat transfer, the equilibrium temperature depends on the thermal conductivity of the gas surrounding the filament. Thus any difference between the thermal conductivity of reference and sample gases causes an imbalance in the bridge; this imbalance (as a millivolt signal) is indicated by the display unit.

Zener diodes are connected across the input connections from the power supply unit to the katharometer in order to limit the maximum voltage that could be developed across the filament bridge under external fault conditions. Under fault conditions the current is limited to a safe value by the power supply unit.

### 2.3 Model 4234 500/4234 501 Power Supply Units (PSU) – Fig. 3.3

**Caution.** Do not connect the mains supply to the PSU with the output terminals open circuit.

**Caution.** Ensure that the PSU is correct for the mains supply voltage available. A nominal 115V unit cannot be adapted for use with a nominal 230V supply, or vice versa.

To operate a katharometer unit in the hazardous area, one Model 4234 PSU is required for each katharometer. The PSU supplies a stabilized DC current output and **must** be mounted in the **safe** area. There are two versions available:

Model 4234 500 for a nominal 230V AC supply voltage

Model 4234 501 for a nominal 115V AC supply voltage

The stabilized current output is current and voltage limited to restrict the energy supply into the hazardous area.

The PSU is housed in a metal case fitted with lugs for wall/panel mounting. Cable gland entries are provided at opposite ends of the case for supply voltage input and stabilized current output cables to the hazardous area.

The circuit is protected by cartridge fuses. These fuses **must** have a high breaking capacity (HBC) rating of 1500A to comply with the terms of the certification.

### 2.4 Remote Indicator/Controllers

The 6553 Display Unit has retransmission outputs for connection to indicator/controllers, providing that they are installed in the **safe** area and the installation conforms to the requirements given in Section 5.1.

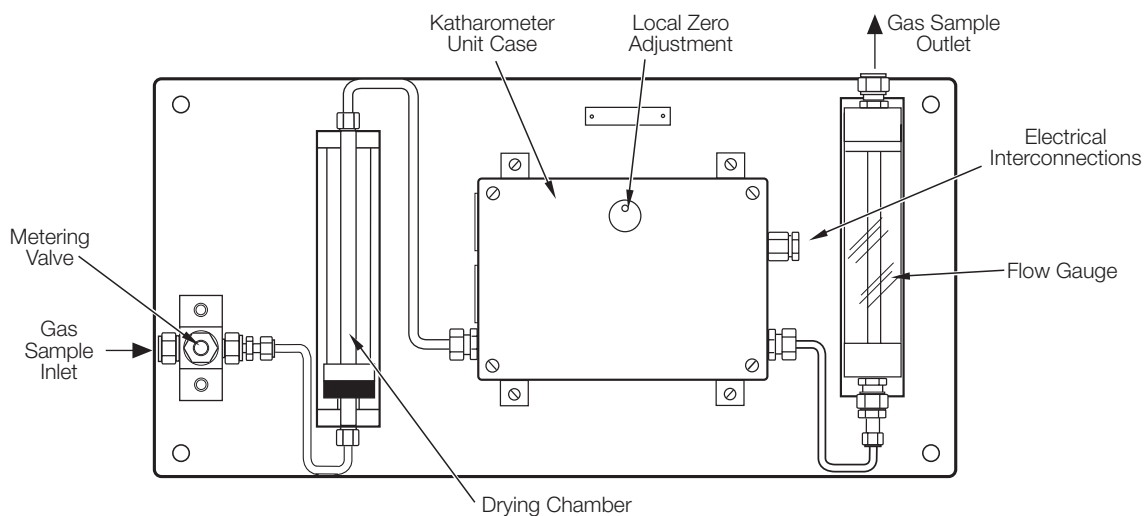

Fig. 2.2 Location of Items – Model 6540 203 and 6548 000 Katharometer Analyzer Panels

### 3 PREPARATION

#### 3.1 Identification

It is essential that installers and users clearly identify the various units of the monitoring system as follows:

##### 3.1.1 Model 6553 Display Unit – Fig. 3.1

Several versions of the 6553 Display Unit are available and are defined by the code number explained in Section 3.1.4.

Identification and certification labels are fixed to the outside of the display unit case as shown in Fig. 3.1. Use the ordering code table in Section 3.1.4 to interpret the identification label code and obtain a precise description of the 6553 Display Unit.

**Note.** Location of the identification label on the 4689 display unit is also shown in Fig. 3.1.

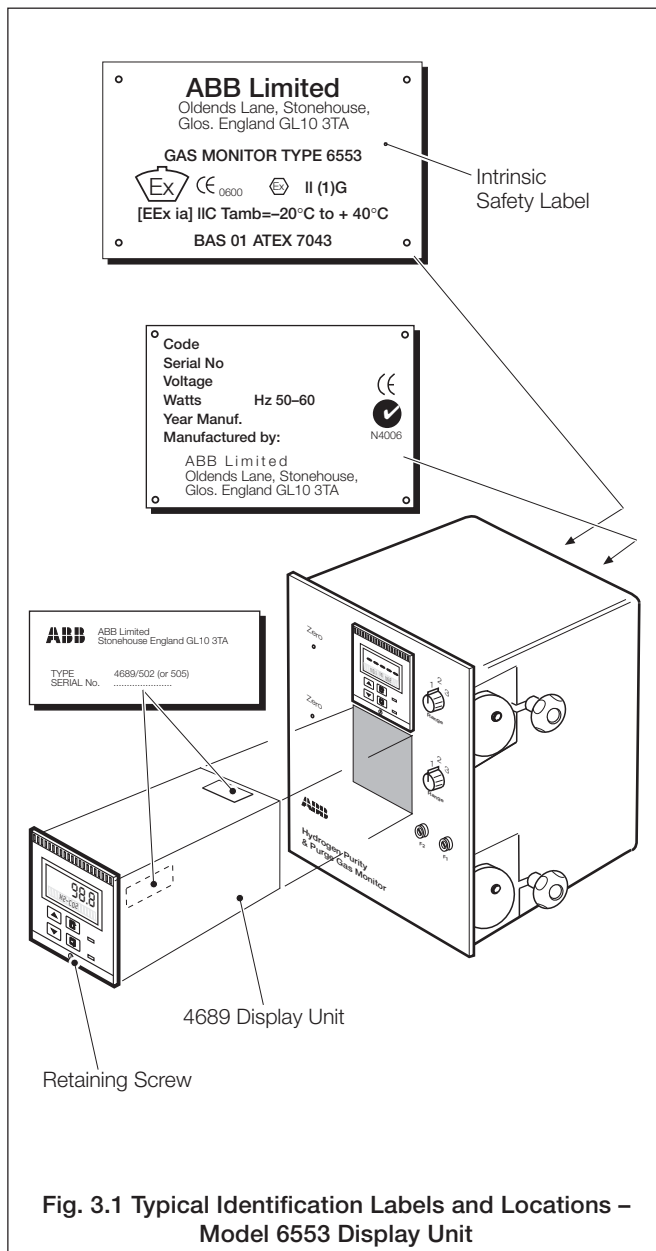

**Fig. 3.1 Typical Identification Labels and Locations – Model 6553 Display Unit**

##### 3.1.2 Model 006540 203 or 006548 000 Katharometer Analyzer Panel – Fig. 3.2

The panel is identified by the reference number label as shown in Fig. 3.2. The identification and certification labels of the individual katharometer units (fixed to the katharometer case) are also shown in Fig. 3.2.

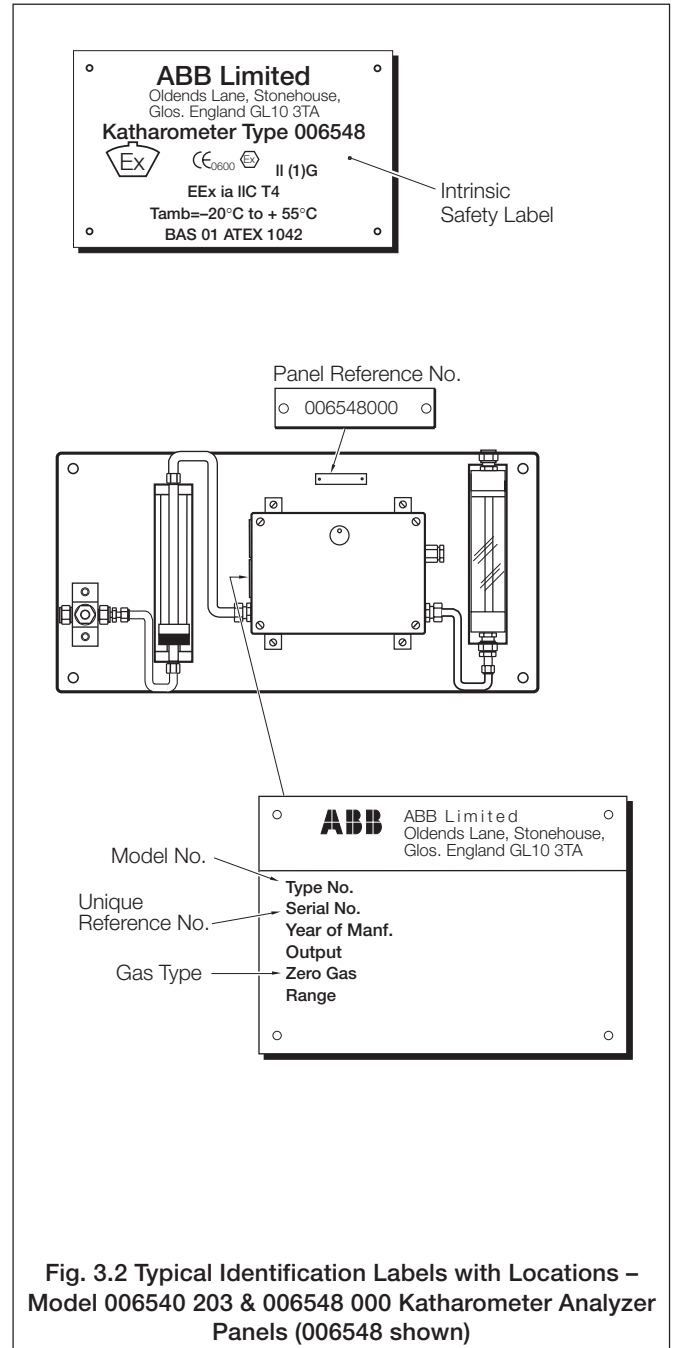

**Fig. 3.2 Typical Identification Labels with Locations – Model 006540 203 & 006548 000 Katharometer Analyzer Panels (006548 shown)**

### 3.1.3 Model 4234 Power Supply Unit – Fig. 3.3

The identification and certification labels are fixed to the outside of the unit case, as shown.

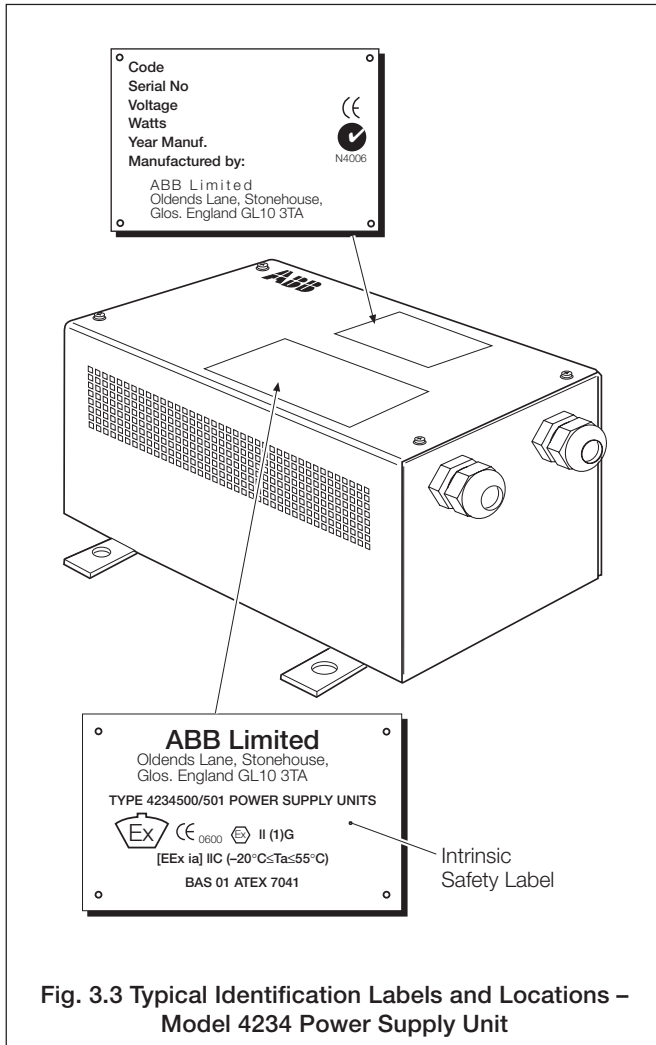

Fig. 3.3 Typical Identification Labels and Locations – Model 4234 Power Supply Unit

## 3.1.4 AK100 Ordering Information

ATEX Compliant Gas Analyzer for Hydrogen-cooled Alternators	AK10	X /	X	X	X	X	X	X	X	X
<b>Display Monitor Unit</b>										
Separate H <sub>2</sub> Purity & Purge Gas Displays		1								
Dual 3-range Displays (H <sub>2</sub> Purity and 2 x Purge Gas)		2								
Single 3-range (H <sub>2</sub> Purity and 2 x Purge Gas)		3								
Single Hydrogen Purity Display		4								
<b>Hydrogen Purity Range</b>										
80/85% to 100%			1							
100% to 85% (does not conform to ATEX directive)			2							
100% to 80% (does not conform to ATEX directive)			3							
<b>Purge Gas</b>										
None (AK104 only)				0						
CO <sub>2</sub>				1						
Argon				2						
Nitrogen				3						
<b>Gas Analysis Panel*</b>										
None					0					
Low pressure (for vent to atmosphere 0.35barg (5 psi) max.					1					
Low pressure & flame traps (for vent to atmosphere 0.35barg (5 psi) max.					2					
High pressure for closed loop 10barg (145 psi) max.					3					
<b>Cubicle</b>										
Without cubicle						0				
With cubicle						1				
With cubicle plus isolator †						2				
With cubicle plus isolator plus MCBs and power supply indicators †						3				
<b>Gas Sample Flow Alarm (only available with Cubicle option)</b>										
Not fitted							0			
One flow alarm fitted AK103 and AK104 (single gas analysis panel versions)							1			
Two flow alarm fitted AK101 and AK102 (dual gas analysis panel versions)							2			
<b>Katharometer Power Supply***</b>										
None								0		
115V 50/60Hz								1		
230V 50/60Hz								2		
<b>Special Feature</b>										
None									0	
Special									9	
<b>System Labels and Instruction Manuals**</b>										
English										1
French										2
German										3
Polish										7

\* Two Gas Analysis panels are required for AK101 and AK102.

\*\* Check with Factory for availability.

\*\*\* Two Katharometer Power Supplies are required for AK101 and AK102.

† Not normally fitted to AK102 systems that require 100% redundancy.

The equipment conforms with the requirements of ATEX directive for Class IIC gases to Code EEx ia IIC provided that the equipment is installed in accordance with instructions provided.

## 4 MECHANICAL INSTALLATION

### 4.1 Locating and Mounting System Items

#### 4.1.1 Models AK102 and AK103 Display Unit – Fig. 4.1

**Note.** The display unit **must** be located in the **safe** area of the application plant in a sheltered interior environment.

The display unit is designed for panel mounting in a position to suit reading of the displays and with access to the rear for electrical wiring interconnections. The panel preparation requirements and installation dimensions are shown in Fig. 4.1. The display unit is secured to the panel by four adjustable cam brackets – two each side of the unit chassis.

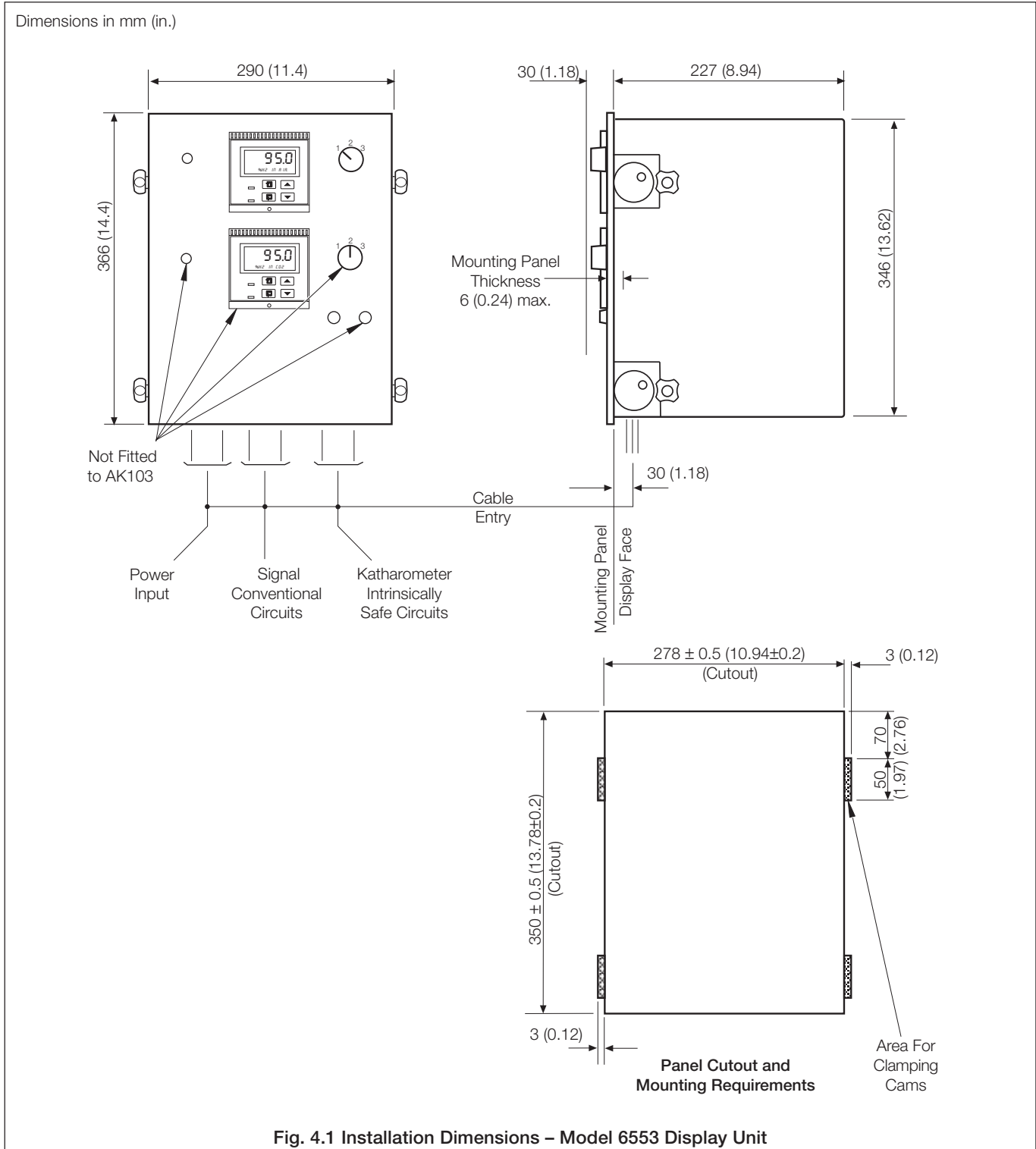

## 4.1.2 Katharometer Analyzer Panel – Fig. 4.2

**Note.** The panel is located in the hazardous area (Zone 0, 1 or 2) of the application plant in a sheltered interior environment.

Avoid a location that subjects the katharometer unit to direct sunlight. When two katharometer panels are used locate them in positions that have the same ambient temperature.

The katharometer unit is fixed to the panel that has fixing holes at each corner for mounting on a suitable vertical surface close to the sample tapping point. The installation dimensions for the panel are shown in Fig. 4.2.

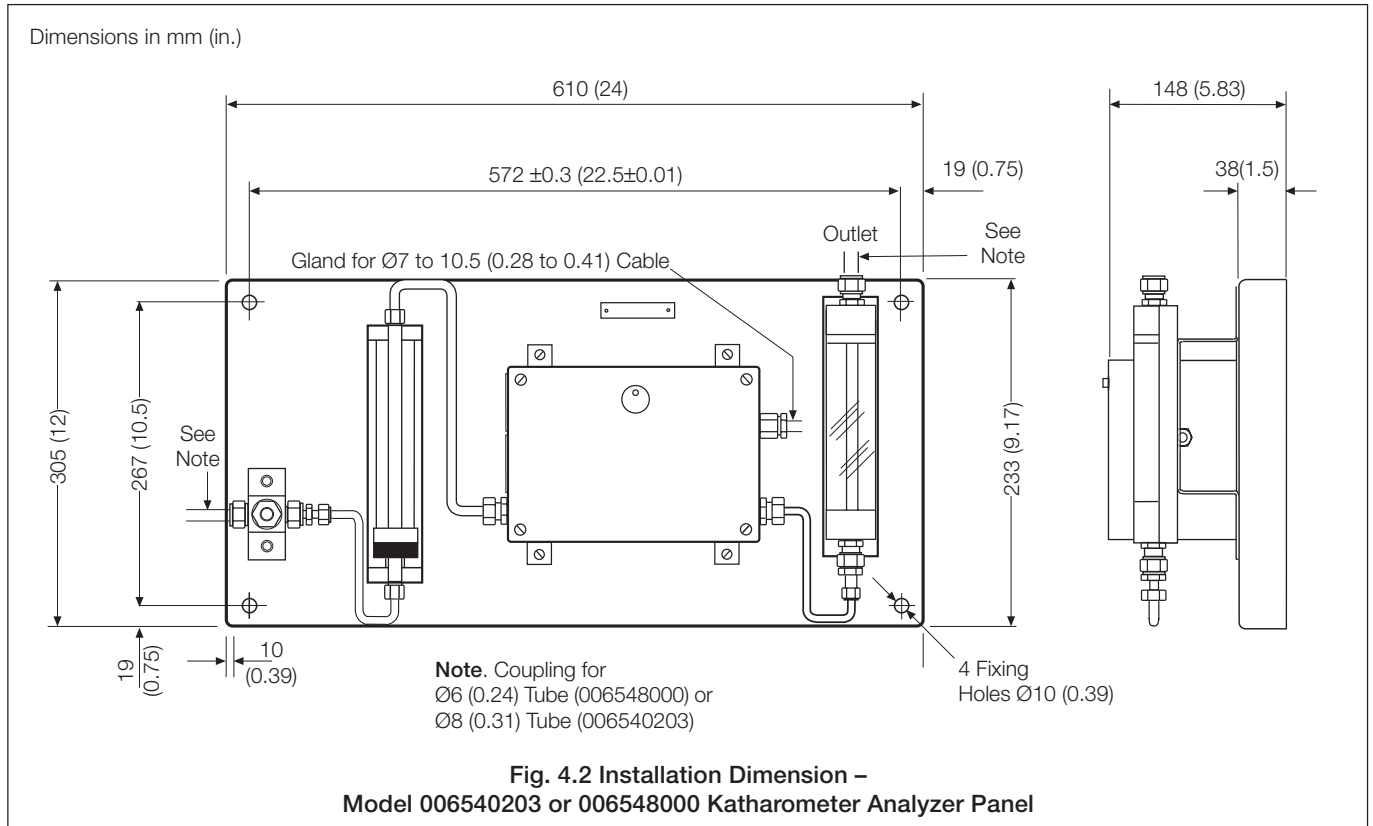

## ...4 MECHANICAL INSTALLATION

### 4.1.3 Model 4234 Power Supply Unit – Fig. 4.3

**Note.** The unit **must** be located in the **safe** area of the application plant in a sheltered interior environment.

The power supply unit has four fixing lugs for mounting on a suitable vertical surface. The installation dimensions are shown in Fig. 4.3.

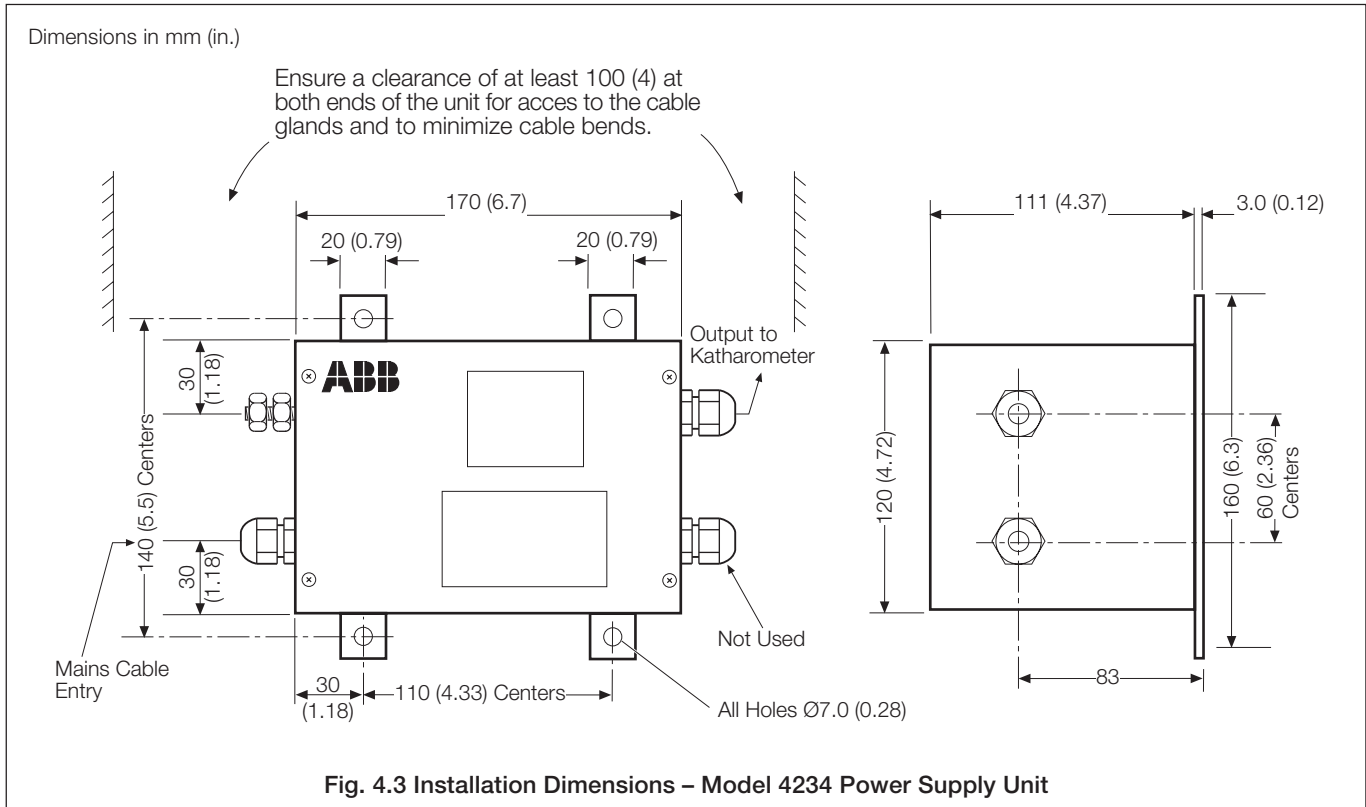

**4.1.4 Cubicle Mounted System – Figs 4.4 and 4.5**

The cubicle **must** be located in a **safe** area of the application plant and mounted either on the base using four M10 fixings or to a vertical surface using the four fixing brackets on the back-plate.

Overall dimensions of the cubicle are given in Fig. 4.4 and the principal base case components are shown in Fig. 4.5.

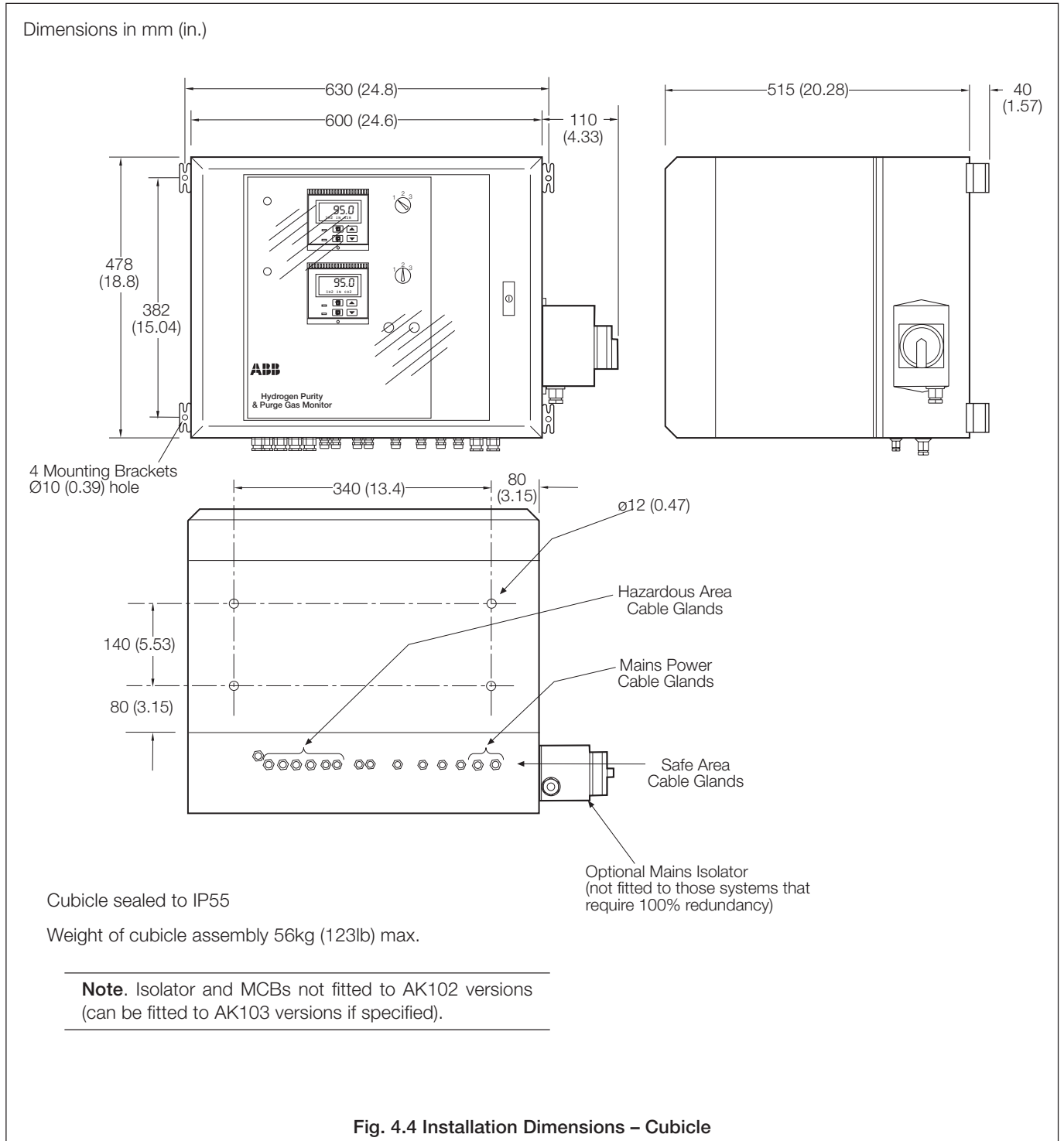

## ...4 MECHANICAL INSTALLATION

### 4.2 Sample Gas Interconnections

**Note.** A hazardous mixture of hydrogen in air could develop in the event of leakage from the sample gas system. Mount katharometer analyzer panels in a ventilated area.

The sample pressure must not exceed 0.35 bar (Gauge) for Model 6540 203 or 10 bar (Gauge) for Model 6548 000.

The incoming sample gas temperature must not exceed 55°C (131°F). Ideally the sample gas temperature should be allowed to reach ambient temperature before entry to the Katharometer unit.

If there is a risk of significant particle contamination incorporate a suitable 1µm filter unit in the system before the sample gas enters the analyzer system.

Compression couplings are supplied at the sample inlet and outlet to the katharometer panel. These couplings are suitable for connecting 8mm (0.31 in.) (Model 006540 203) or 6mm (0.24 in.) (Model 006548 000) outside diameter metal tube. It is recommended that stainless steel tube is used.

The complete tubing system should be tested for leaks in accordance with the requirements of the responsible authority.

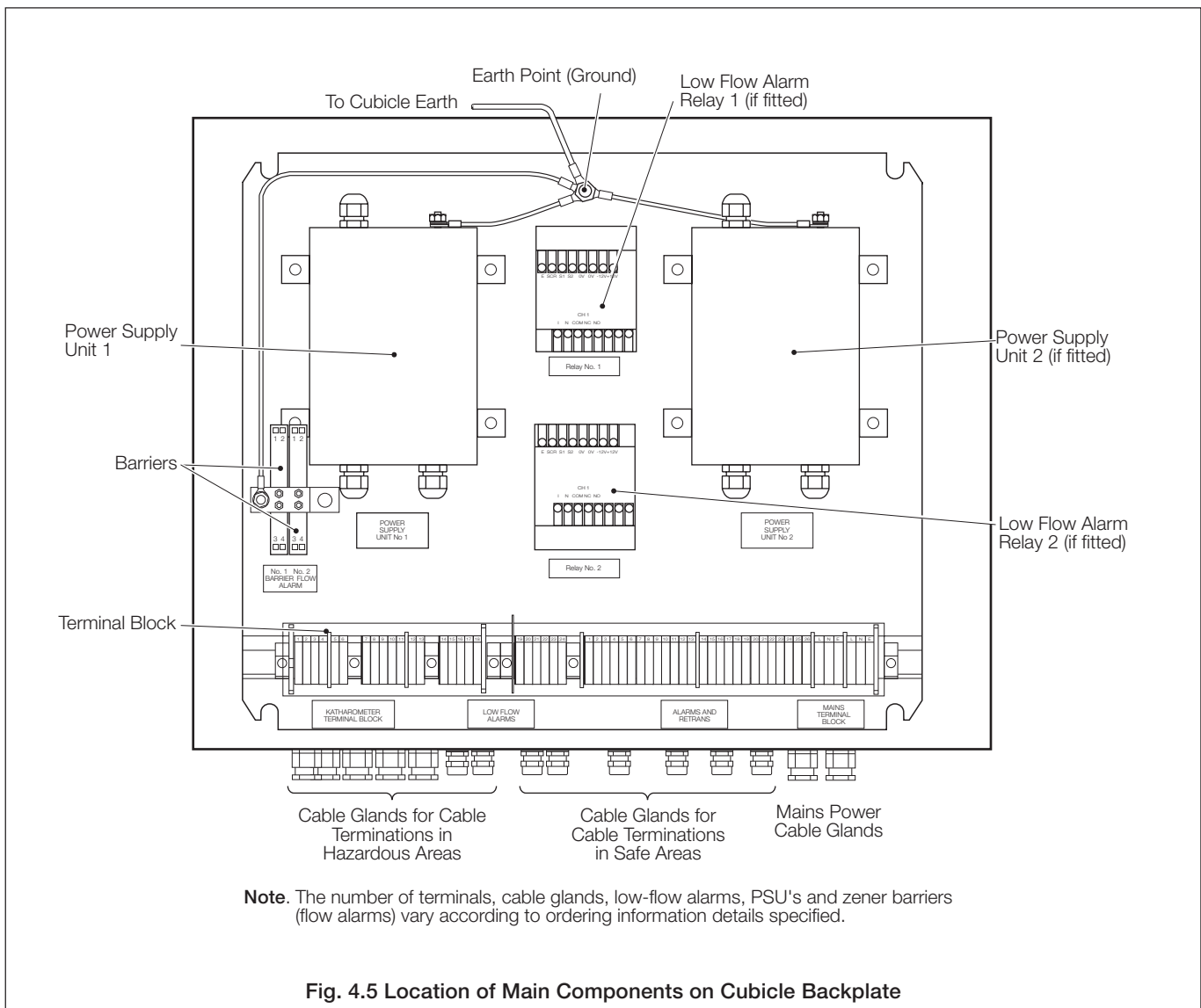

**Fig. 4.5 Location of Main Components on Cubicle Backplate**

# 5 ELECTRICAL INSTALLATION

## 5.1 Electrical Interconnections – Fig. 5.1

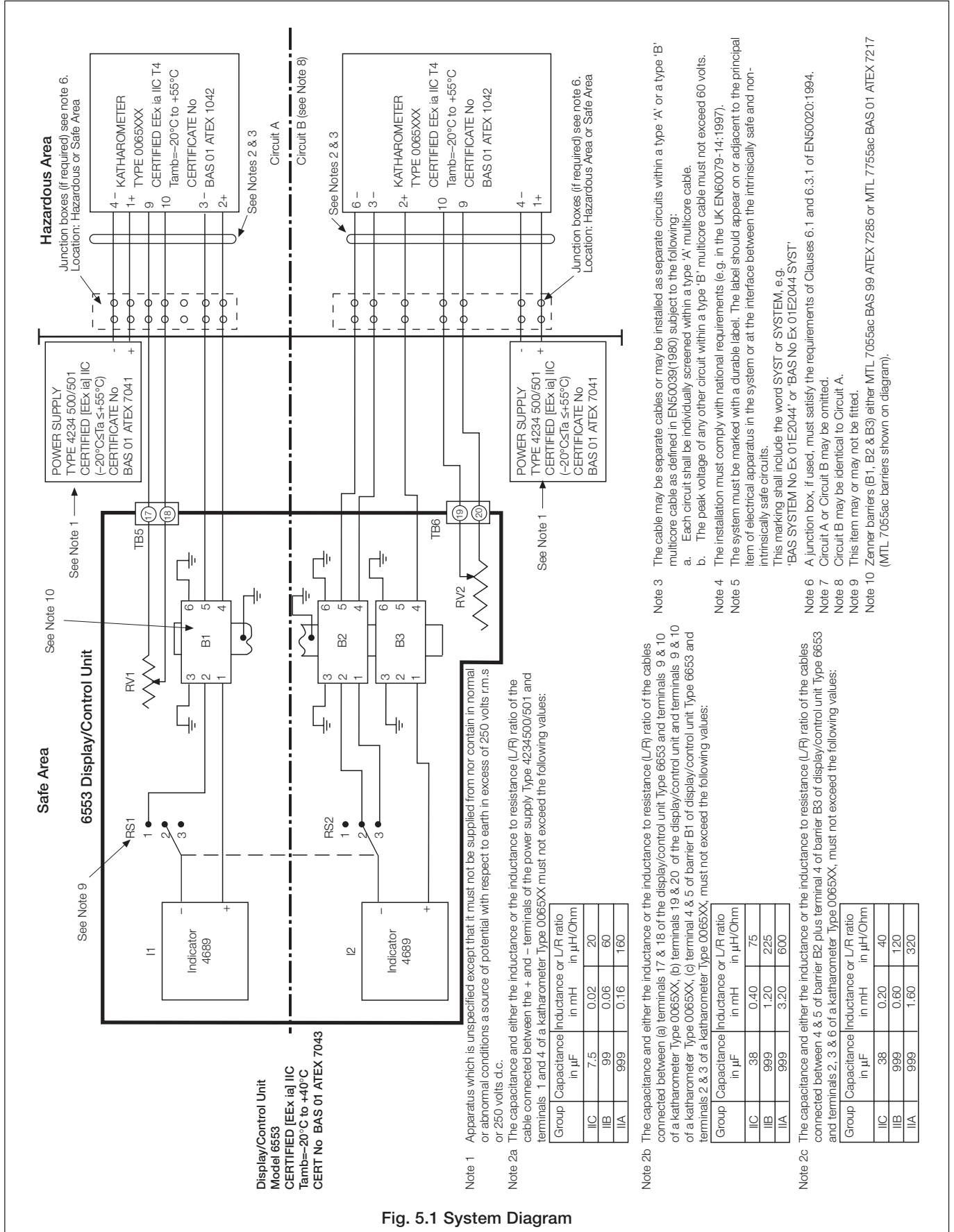

Fig. 5.1 System Diagram

**Warning.**

- Equipment in this system operates on AC mains supply voltage electricity. Suitable safety precautions must be taken to avoid the possibility of electric shock.

**Caution.**

- Although certain instruments are fitted with internal fuse protection, a suitably rated external protection device, either a 3A fuse or miniature circuit breaker (MCB) must also be fitted by the installer.
- The proper electrical connections and wiring standards must be achieved to establish the intrinsic safety of the system, as certified.
- AC input, intrinsically safe DC output and non-intrinsically safe wiring must all be routed separately.

**5.1.1 Model 6553 Display Unit – Fig. 5.2**

**Caution.** No connections must be made to the hazardous area terminals (Terminal Blocks TB5 & TB6) other than as specified in wiring diagram Fig. 5.3. The appropriate cable requirements must be strictly adhered to.

Remove the outer case from the back of the unit to gain access to the terminal blocks.

Make electrical connections through the bottom of the unit into the terminal blocks immediately above them – see Fig. 5.2.

The alarm and signal outputs on terminal blocks TB3 & TB4 may be connected as required. The availability of signal outputs vary with the particular 6553 system – refer to Fig. 5.3 for details.

Make the wiring connections in accordance with the information given in the wiring diagram Fig. 5.3 and Section 5.1.

Refer Fig. 5.4 for connections to cubicle-mounted display unit.

Continued on page 17.

Fig. 5.1 shows the interconnecting wiring requirements for the AK100 Gas Analyzer system, that must be strictly observed. Details of cable requirements, that must be strictly adhered to, are also given – see Section 5.2.1.

After completing the wiring, check that the continuity earthing (grounding) and isolation of all circuits is to the required local electrical standards for intrinsically safe circuits.

The separate units of the Analyzer system must be interconnected as shown in Sections 5.1.1, 5.1.2 and 5.1.3.

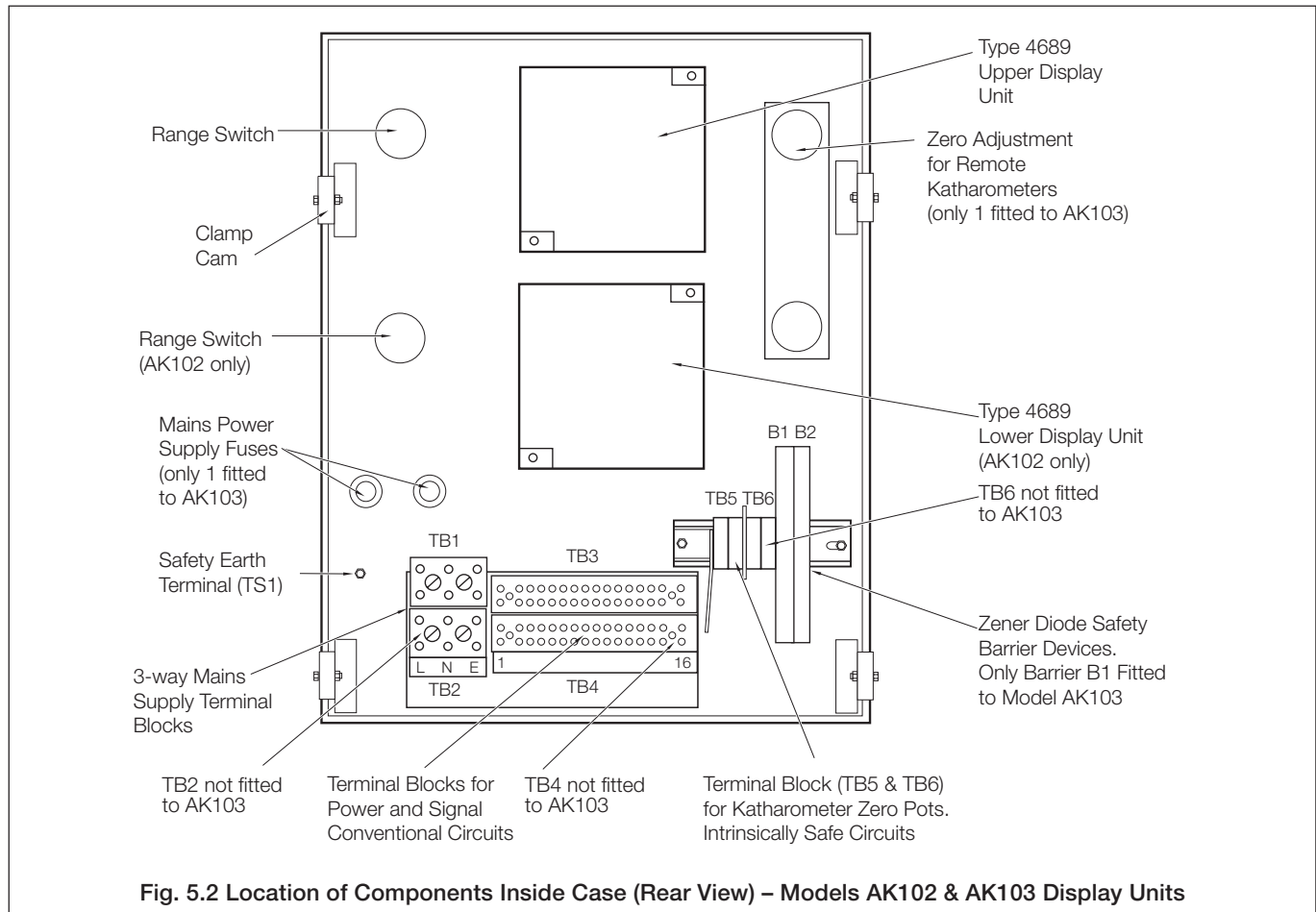

**Fig. 5.2 Location of Components Inside Case (Rear View) – Models AK102 & AK103 Display Units**

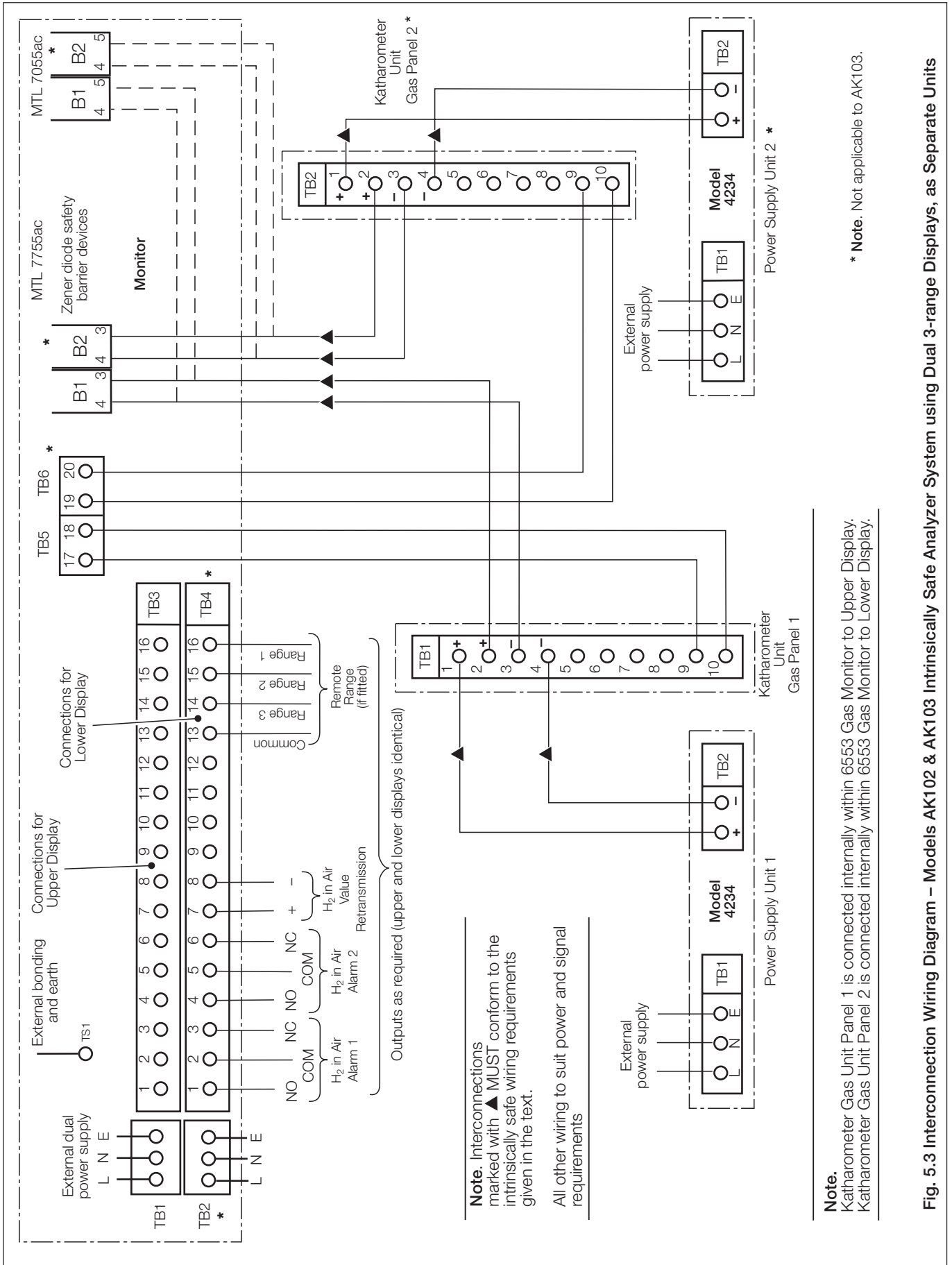

Fig. 5.3 Interconnection Wiring Diagram – Models AK102 & AK103 Intrinsically Safe Analyzer System using Dual 3-range Displays, as Separate Units



**Caution.** The integrity of the fail-safe operation of the zener diode safety barrier devices depends on a Safety Earth connection which must not have a resistance greater than 1  $\Omega$  to the application plant earth (ground).

Make the Earth (Ground) and **Safety Earth** connection at the stud (TS1) – see Fig. 5.2.

On completion of wiring and checks, replace the outer case and secure the clamping brackets to the mounting panel.

### 5.1.2 Model 006540 203 and 006548 000 Katharometer Analyzer Panel

To gain access to the connection terminal block TB1:

- 1) Remove four screws in the cover of the katharometer unit.
- 2) Remove cover

Make the electrical connections to the Display Unit in accordance with the information given in wiring diagrams in Figs 5.3, 5.4 and 5.5 and Section 5.2.

The electrical connections are made at the terminal block (TB1) via the cable gland or any replacement gland to suit the intrinsically safe wiring requirements. When the appropriate interconnections have been made, if remote zero is to be used, remove the 510 dummy remote zero resistor from across terminals 9 and 10 and set the zero adjustment potentiometer on the katharometer to the approximate mid-point.

Replace the cover when wiring is complete.

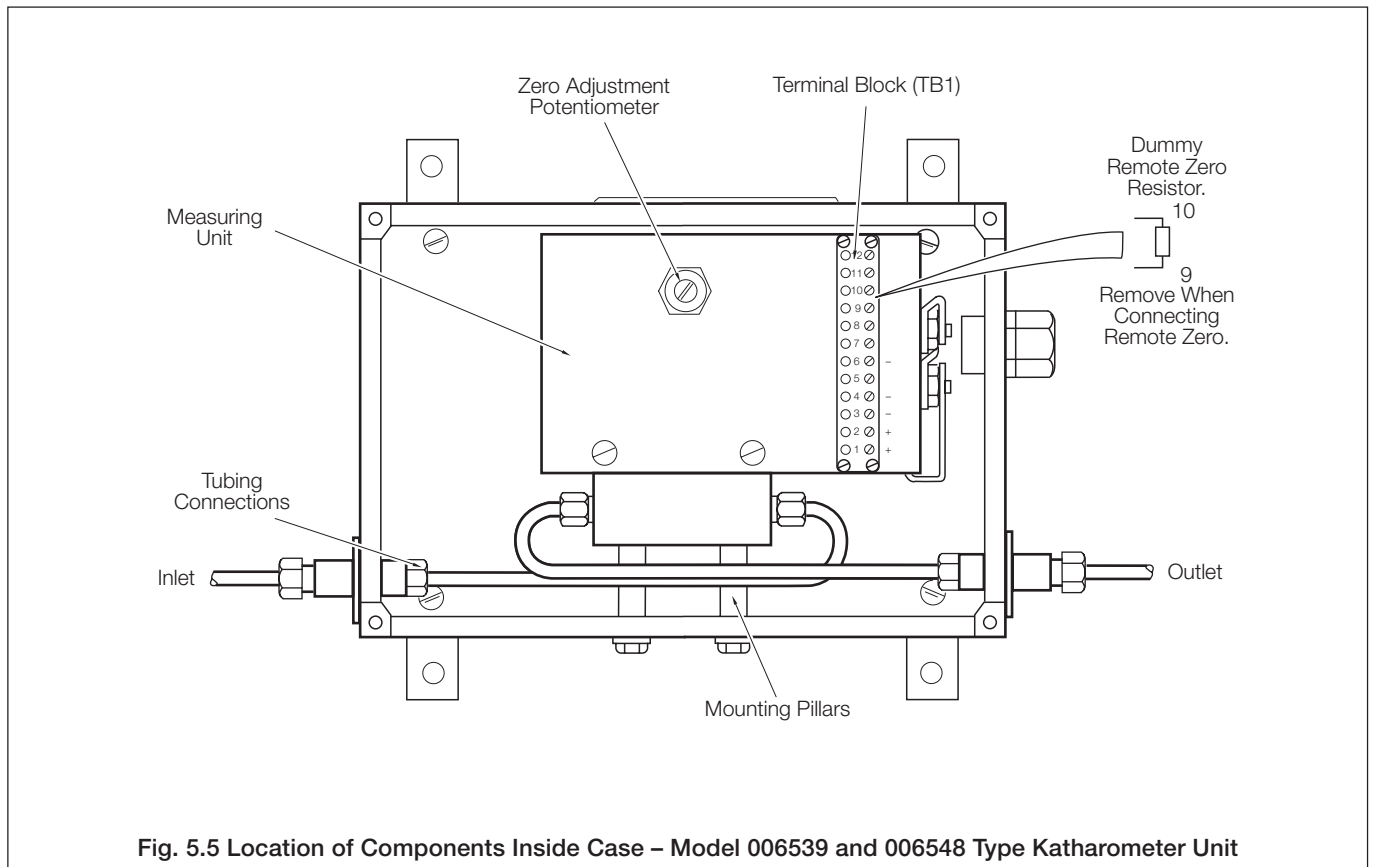

## ...5 ELECTRICAL INSTALLATION

### 5.1.3 Model 4234 Power Supply Unit – Fig. 5.6

**Caution.** Do NOT connect mains supply to the power supply unit with the output terminals on open circuit.

**Note.** Ensure that the power supply unit is correct for the mains supply voltage available. A nominal 115V unit cannot be adapted for use with a nominal 230V supply or vice versa.

Remove the cover of the unit to gain access to the terminal blocks inside.

Identify the terminal block (TB1) adjacent to the transformer T1 and ensure the correct transformer tapping is used for the incoming mains supply, i.e.

- link from tapping 6 to 10 for 230V, or
- link from tapping 8 to 10 for 115V.

Make electrical connections in accordance with the information given in the wiring diagrams Figs 5.1 and 5.3 and the cable details in Section 5.2.1.

The electrical connections are made at terminal blocks TB1 and TB2 through the appropriate cable gland or any replacement gland to suit intrinsically safe wiring requirements. Secure the incoming cable by the cable clips adjacent to the terminal blocks.

Replace the cover when wiring is complete.

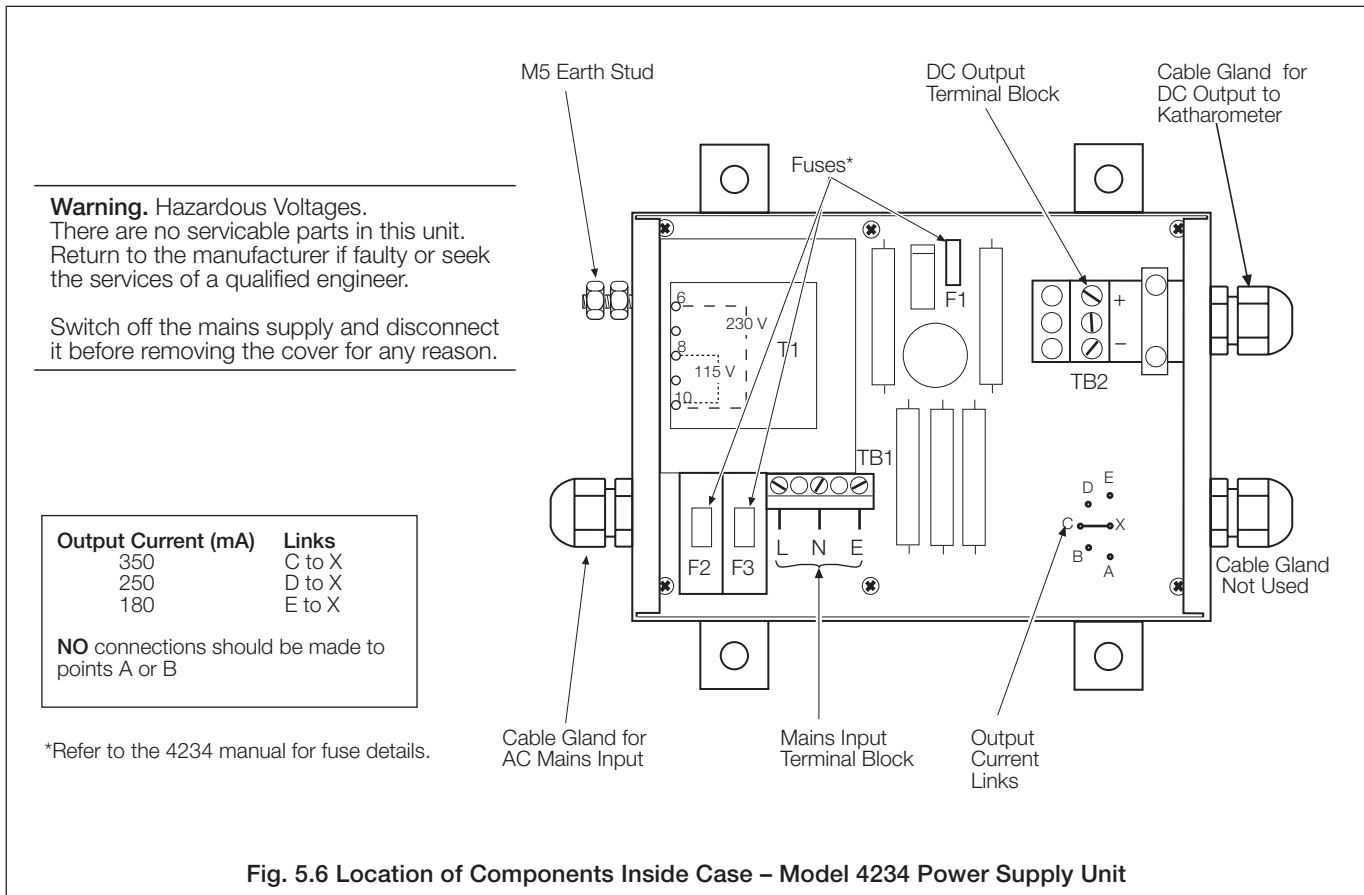

## 5.2 Intrinsically Safe Requirements

These requirements relate to the interconnecting wiring made to and from Model 6540 203 and 6548 000 Katharometer Analyzer Panels in the hazardous area and those for remote ancillary items connected to the system.

### 5.2.1 Cable Requirements

The interconnecting cables between the various units of the gas analysis system are subject to stringent limitations because of the requirements of the intrinsic safety certification. These are listed below and detailed in Fig. 5.1.

All cables entering the **hazardous** area must be kept separate from cables in the **safe** area. Cables entering the **hazardous** area must not be run with other cables and terminations must have an earthed screen to separate them from connections for other circuits. The detailed requirements are as follows:

#### 1) Connections between Model 006540 203 or 006548 000 Katharometer Analyzer Panels and the 4234 PSU

All cables from the Katharometer in the hazardous area must have an inductance/resistance ratio not exceeding 20 $\mu$ H/ (for Group IIC gases). Also the maximum loop resistance of this interconnecting cable is limited to 1.5 ; this may place a limitation on the length of the total cable run.

Twist single sheathed conducting cables together to reduce their mutual inductance and route them separately from cabling for non-intrinsically safe circuits in the safe area.

#### 2) Connections between Model 006540 203 or 006548 000 Katharometer Analyzer Panels and Model 6553 Display Unit

Katharometer to display unit cables, carrying the output signals through zener barrier units inside the display unit, are subject to of a maximum inductance/resistance ratio of 20 $\mu$ H/ (for group IIC gases). These wires are indicated by a ▲ in Fig. 5.3.

### 5.2.2 Recommended Cables

The choice of wiring cable is restricted by the limitations imposed by the certification parameters. Care must be taken to ensure that the specification of the cable required for interconnection lengths is such that the certification parameter limits are not exceeded – see Notes 2a, b and c in Fig. 5.1.

Cables manufactured to DEF STAN 61-12 Part 5 should comply, but care must be taken over the number or cores included in the cable; there is a significant difference between the 2-core and 6-core cables. The diameter over the screen in the 6-core cable is greater than that of the 2-core and this diameter affects both the inductance and capacitance values.

The values of a typical DEF STAN 61-12 Part 5 cable are:

	2-core	6-core
Inductance ( $\mu$ H/metre)	0.325	0.467
Capacitance (pF/metre)	190	143
L/R ( $\mu$ H/)	8.6	11.4
Test voltage	2kV AC for one minute	
Rated voltage	440V RMS	

Typical cables may be obtained at the following addresses:

[www.permanoid.co.uk](http://www.permanoid.co.uk)  
[www.Belden.com](http://www.Belden.com)

**Note.** Interconnection lengths and number of cores will dictate which cable is required e.g. Belden 9512 cable.

### 5.2.3 Installing Remote Ancillary Items

Any indicator/controllers, or other electrical equipment, connected to TB1 of the Model 6553 Display Unit must not be supplied from, nor contain, a voltage source greater than 250V DC or 250V RMS with respect to earth.

### 5.2.4 Full Intrinsically Safe Requirements

For systems to be modified or used with other gases the full ATEX requirements must be complied with as follows:

- 1) The total Capacitance and Inductance or Inductance to Resistance ratio (L/R) of the cables connecting the katharometer unit to the hazardous area terminals of the display unit (TB2) and power supply unit terminals (TB1) must not exceed the values in Fig. 5.1.
- 2) Any junction boxes used in the hazardous or safe areas must conform to ATEX Directive 9/94/EC, specifically clauses 6.1 and 6.3.1 of EN50020:1994.

When the AK100 gas analyzer system has been correctly installed in accordance with the requirements for intrinsic safety in Section 5.2 – refer to Section 6 for system set up.

## 6 SETTING UP

**Note.** CO<sub>2</sub> is referred to throughout this manual as the purge gas. However, other gases such as Argon or Nitrogen may be used instead.

### 6.1 Katharometer Analyzer Panel – Filling the Drying Chamber – Fig. 6.1

- 1) Remove the drying chamber on the katharometer analyzer panel by unscrewing the large knurled nut at the base of the chamber. Pull the chamber down and out of the sealing groove to remove it from the panel.

**Note.** The desiccant used in the drying chamber is either granular anhydrous calcium sulphate or calcium chloride and absorbs moisture from the atmosphere. The drying chamber has a capacity of 140ml approx. and requires approx. 100g of desiccant to fill it. Filling and resealing must be carried as quickly as possible.

- 2) Open a container of fresh desiccant and fill the drying chamber.
- 3) Replace the drying chamber in its sealing groove and reposition the chamber to enable it to be secured and sealed by hand tightening the knurled nut.
- 4) Carry out an approved leak testing procedure before passing sample gas through the system.

### 6.2 Setting Sample Flow

When all tubing interconnections have been made and external parts of the sample system checked for leaks, carry out the following procedure:

- 1) Supply calibration quality CO<sub>2</sub> or Argon through the gas analyzer system at the normal working pressure of the application plant and within the following limits:

**Model 6540-203**

125mm H<sub>2</sub>O min. to 0.35bar (gauge) max.

**Model 6548-000**

125mm H<sub>2</sub>O min. to 10bar (gauge) max.

**Note.** In some instances testing for leaks with CO<sub>2</sub> or argon may not be considered an adequate check of gas tight integrity in respect of the more penetrating hydrogen gas. Consideration should be given to the use of a gas, such as helium, which has penetrating properties nearer to that of hydrogen.

- 2) Slowly open the metering valve to give a nominal flowrate of gas of 100 to 150ml min<sup>-1</sup>. Do not exceed the maximum flowrate 250ml/min.
- 3) Set the flowrate and shut off the calibration gas external to the analyzer system.
- 4) Repeat this procedure for each katharometer analyzer panel, as required.

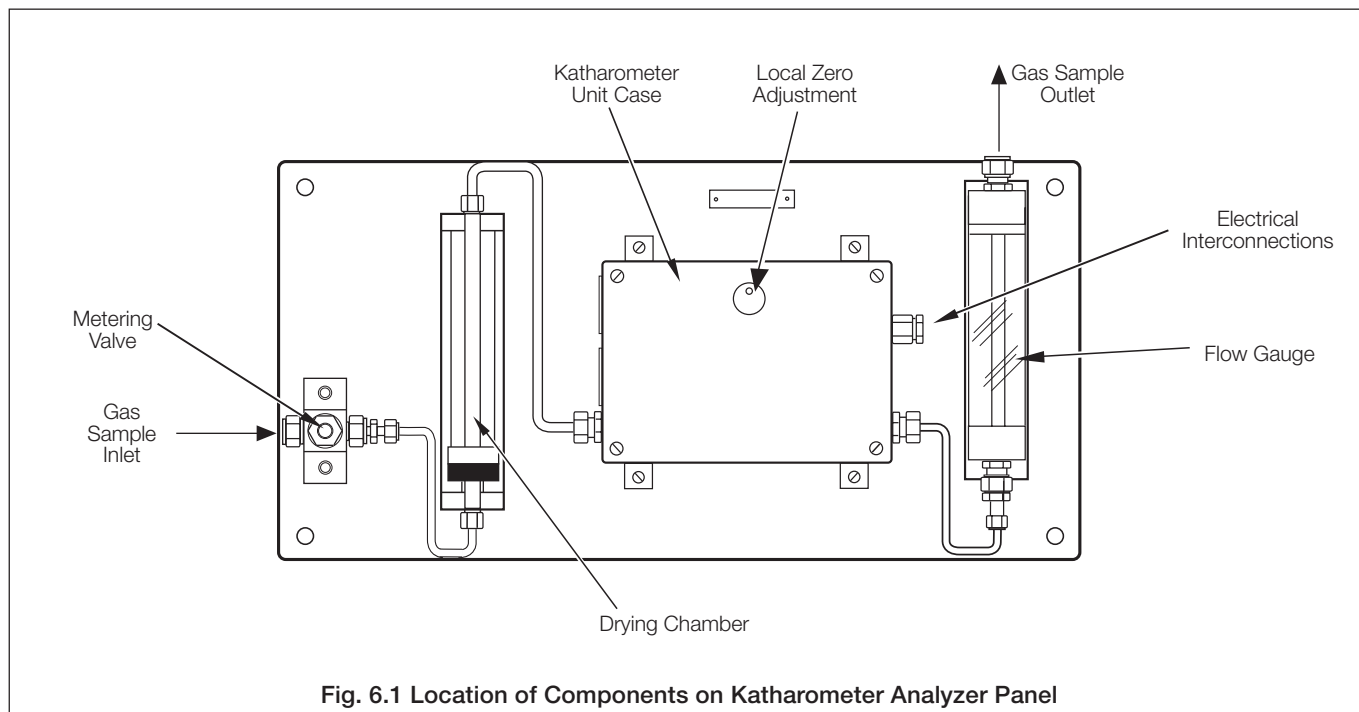

Fig. 6.1 Location of Components on Katharometer Analyzer Panel

### 6.3 Electrical Checks

Carry out the electrical checks detailed in Sections 6.3.1 and 6.3.2.

#### 6.3.1 Power Supply Unit Output

---

**Warning.** This unit is part of the certified intrinsically safe system. Appropriate safety precautions must be taken to prevent any incendive electrical discharges in the hazardous area when carrying out this task.

---

**Testing the output may only be carried out with the hazardous area cable disconnected.**

- 1) Electrically isolate the PSU.
- 2) Remove the cover from the PSU.
- 3) Disconnect the output wires to the hazardous area at terminals TB2+ and TB2-.

---

**Warning.** Ensure that proper electrical safety precautions are taken at all times when undertaking this procedure.

---

- 4) Switch on the PSU and check that the output measures 350mA into a 14 load.
- 5) On completion of tests isolate the unit and reconnect the output wires to the hazardous area.

#### 6.3.2 Zener Diode Safety Barrier Devices

The zener diode safety barrier devices (MTL7755ac or MTL7055ac) in the 6553 Display Unit are checked at the time of manufacture. To ensure absolute safety when fitting a new instrument, check that the barriers in the display unit are properly earthed by carrying out a routine test before using the analyzer system.

---

**Warning .**

- This unit is part of the certified intrinsically safe system. Appropriate safety precautions must be taken to prevent any incendive electrical discharges in the hazardous area when carrying out this task.
  - If these tests reveal a faulty zener barrier, the barrier **MUST** be replaced by a new unit. The barrier is a sealed unit and no repair is permitted. The correct zener barriers are certified intrinsically safe and conform to the ATEX Directive 9/94/EC, certificate number BAS 01 ATEX 7217 (MTL 7755ac) or BAS 99 ATEX 7285 (MTL 7055ac).
  - Replacement Zenner barriers **MUST** be of the same type.
- 

#### 6.3.3 Checking System Earth

Check that the resistance between earth terminals on the analyzer system and the application plant system safety earth does not exceed 1 .

# 7 CONTROLS & DISPLAYS

## 7.1 Displays – Fig. 7.1

The display mounted in the 6553 panel comprises a 5-digit, 7-segment digital upper display line and a 16-character dot-matrix lower display line. The upper display line shows actual values of hydrogen purity, hydrogen in air, air in carbon dioxide, alarm set points or programmable parameters. The lower display line shows the associated units or programming information.

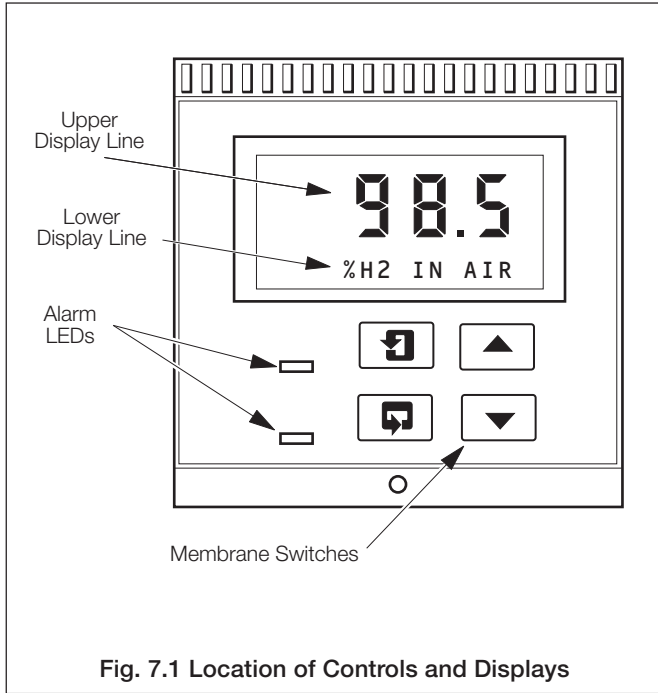

## 7.2 Switch Familiarization – Figs. 7.1 and 7.2

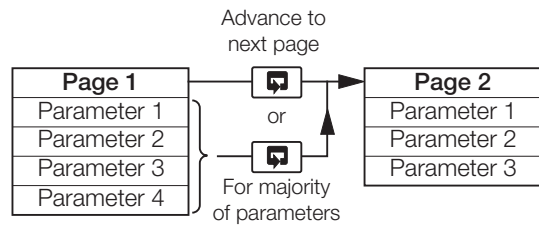

**A – Advancing to Next Page**

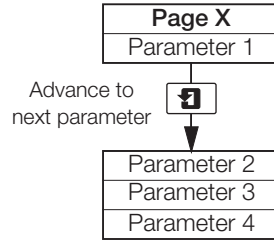

**B – Moving Between Parameters**

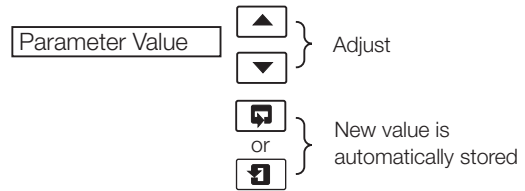

**C – Adjusting and Storing a Parameter Value**

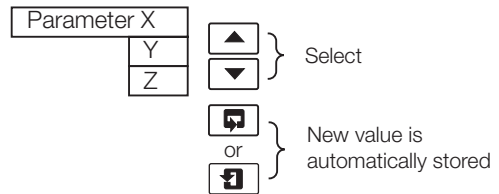

**D – Selecting and Storing a Parameter Choice**

**Fig. 7.2 Function of the Membrane Switches**

---

## 8 START-UP

---

---

**Warning.** When the apparatus is connected to its supply, terminals may be live and the opening of covers or removal of parts (except those to which access may be gained by hand) is likely to expose live parts.

---

---

**Note.** CO<sub>2</sub> is referred to throughout this manual as the purge gas. However, other gases such as Argon or Nitrogen may be used instead.

---

### 8.1 Instrument Start-Up

In normal operation, the range selector switch is set to position 1 and the instrument displays the **Range 1 Operating Page** – see Section 9.2. This is a general use page in which the alarm set points may viewed but not altered. To change an alarm set point or program a parameter refer to Section 10. A 5-digit Security Code is used to prevent unauthorized access to programmable parameters. The value is preset at 00000 to allow access during commissioning but should be altered to a unique value, known only to authorized operators, as described in the **Setup Outputs Page** – see Section 10.3.

When all the required wiring connections and electrical checks have been made correctly, switch on the power supplies to the various units as follows:

- 1) Switch on the supply to the PSU.
- 2) Switch on the supply to the 6553 Display Unit.

### 8.2 Alarm Set Point

#### 8.2.1 Type of Alarm Action

The alarm relay coil is energized during normal non-alarm relay states and is de-energized upon recognition of an alarm condition, thereby providing 'fail-safe' alarms. For example, with Alarm 1 set point = 95.0%, when the display is indicating greater than 95.0% (plus hysteresis), Alarm Relay 1 is energized and Alarm 1 LED is OFF. When the display indicates less than 95.0% (minus hysteresis), Alarm Relay 1 is de-energized and Alarm 1 LED is ON. This operating mode ensures that an alarm condition is signalled in the event of a mains power failure. Repeat the above procedure for Alarm Relay 2 set point = 90.0%.

#### 8.2.2 Hydrogen Alarm Set Point

It is recommended that the hydrogen alarm set-points are based on a reducing percentage of hydrogen as it is displaced by air entering the application plant. This can be achieved by setting Alarm 1 and Alarm 2 to give ample warning of the development of a potentially explosive mixture. Factory settings are Alarm 1 = 95.0% and Alarm 2 = 90.0%.

The procedure is as follows:

### 8.3 Electrical Calibration

The instrument is factory calibrated for electrical voltage signal input. No adjustment is normally necessary for correct functioning of the display unit. If electrical calibration is required, a voltage source capable of supplying –250.00mV to 10.00 mV is needed. Disconnect the katharometer input from the display unit and the voltage source signal applied according to the instructions in the **Electrical Calibration Page** – see Section 10.

---

**Note.** The 4689 instruments incorporate a two point calibration sequence requiring both zero and span inputs for a calibration. It is not possible to adjust either the range zero or the range span scale points independently.

---

## 8.4 Gas Calibration

### 8.4.1 Introduction

Before putting the system on-line, it is recommended that a calibration check for the 'zero' reading is made using calibration standard sample gas.

The 'zero gas' is marked permanently on the data plate of the katharometer unit. This gas, when passed through the katharometer, gives a zero millivolt output. To provide a fail-safe condition the zero gas is 85% hydrogen in nitrogen mixture so that, if power is lost to the katharometer, an alarm condition occurs at the display unit.

Full scale output from the katharometer is obtained by a 100% hydrogen gas sample and no adjustment of the katharometer output is normally required. The maximum signal for the full scale reading is sealed during manufacture and must not be altered by users.

With the katharometer adjusted correctly using the 'zero gas' hydrogen in nitrogen mixture, carbon dioxide (or argon) and air mixtures are displayed correctly when the selector switch is in the appropriate position.

### 8.4.2 Gas Range Calibration

---

**Note.** Test for leaks in accordance with the requirements of the responsible authority for site safety after making any hydrogen connections.

---

**Note.** The procedure outlined here is not normally necessary as the ranges have been set at the factory.

---

- 1) **Select Range 1**  
Pass an 85% H<sub>2</sub>/15% N<sub>2</sub> gas mixture through the katharometer and allow the reading to stabilize. Adjust the katharometer zero potentiometer or remote zero (if fitted) to give a reading of 85% H<sub>2</sub> in air.
- 2) Pass 100% H<sub>2</sub> through the katharometer and allow the reading to stabilize. If necessary adjust the katharometer span potentiometer (R7) to give a reading of 100% H<sub>2</sub>.
- 3) **Select Range 3**  
Pass 100% CO<sub>2</sub> or Argon through the katharometer and allow the reading to stabilize. Adjust the katharometer span potentiometer (R7) to give a reading of 0% air in CO<sub>2</sub>/Argon.
- 4) Pass 100% air through the katharometer and allow the reading to stabilize. Adjust katharometer span potentiometer (R7) to give a reading of 100% air in CO<sub>2</sub> or argon (only if the reading is greater than 100%).
- 5) **Select Range 1**  
Pass 100% H<sub>2</sub> through the katharometer and allow the reading to stabilize. Adjust the katharometer zero potentiometer or remote zero (if fitted) to give a reading of 100% H<sub>2</sub> in air.
- 6) Repeat steps 3) to 5) and adjust as necessary.

## 9 OPERATION

**Note.** CO<sub>2</sub> is referred to throughout this manual as the purge gas. However, other gases such as Argon or Nitrogen may be used instead.

### 9.1 Normal

During normal operation the AK100 Gas Analyzer System is used to indicate the purity of hydrogen used as a coolant. The display shows the percentage of hydrogen in air, which should be safely in excess of the explosive limit at the hydrogen rich end.

There are no routine adjustments required to the gas analyzer system after completion of start-up procedures and putting on-line in monitoring mode. The system requires only the carrying out of safety routines and minor adjustments to the metering valve to maintain the required flowrate.

A summary of the functions and status of the system for the different range selector switch positions is shown in Table 9.1.

#### 9.1.1 Purging of Hydrogen Coolant Gas

Initially, inert purge gas (CO<sub>2</sub> or argon) is introduced into the system. When the hydrogen concentration is safely below the explosive limit, air is introduced into the system to completely displace the other two gases.

The AK100 Gas Analyzer System provides all the necessary indications and output signals to enable this operation to be carried out safely.

In respect of the operation of the gas analyzer system(s), the procedures are as follows:

**Note.** Suitable safety procedures apply to the operation of gas cooling and sample systems.

- 1) Select position (2) of the range selector switch on the display unit. The displays and functions are shown in Table 9.1.
- 2) Commence the purging operation.
- 3) When the changeover to introduce air into the application plant is made, select position (3) of the range selector switch on the display unit. The displays and functions are shown in Table 9.1.

#### 9.1.2 Filling with Hydrogen Coolant Gas

This procedure is a reversal of the purging procedure.

Initially, inert purge gas (CO<sub>2</sub> or argon) is introduced into the application plant until the air content is safely below the explosive limit for air in hydrogen. When this limit is reached, hydrogen is gradually introduced into the system to displace the other two gases.

With respect to the operation of the gas analyzer system, the procedure is as follows:

**Warning.** Suitable safety precautions apply to the operation of the gas cooling and sample systems.

**Note.** For optimum accuracy it is recommended that the filling operation commences within 24 hours of carrying out the calibration procedure.

- 1) Select position (3) of the range selector switch of the display unit. The displays and functions are shown in Table 9.1.
- 2) When the changeover to introduce hydrogen into the application plant is made, select range (2) of the range selector switch on the display unit. The displays and functions are shown in Table 9.1.
- 3) When the display indicates that hydrogen filling is complete, position the range selector switch at (1). The hydrogen measurement analyzer system is now ready for monitoring H<sub>2</sub> concentration on-line – see Section 9.2.

Range Selector Switch Position	Upper Display Line		Lower Display Line		Alarm 1 + 2 Set Point and Retransmission
	Actual Display	Function	Actual Display	Function	
(1)	xxx.x	Variable Value	%H <sub>2</sub> IN AIR	Hydrogen Purity	As required
(2)	xxx.x	Variable Value	%H <sub>2</sub> IN CO <sub>2</sub> or Ar	Purge Gas	Inhibit
(3)	xxx.x	Variable Value	%AIR IN CO <sub>2</sub> or Ar	Purge Gas	Inhibit

**Table 9.1 Functions and Status of Display Units for Different Range Selector Switch Positions**

## 9.2 Range 1 Operating Page

Range 1 is selected for normal operations and the **Operating Page** indicates the purity of the hydrogen used as a coolant. The alarm set points can be viewed but not altered. To change the alarm set points or program other parameters, refer to Section 10.

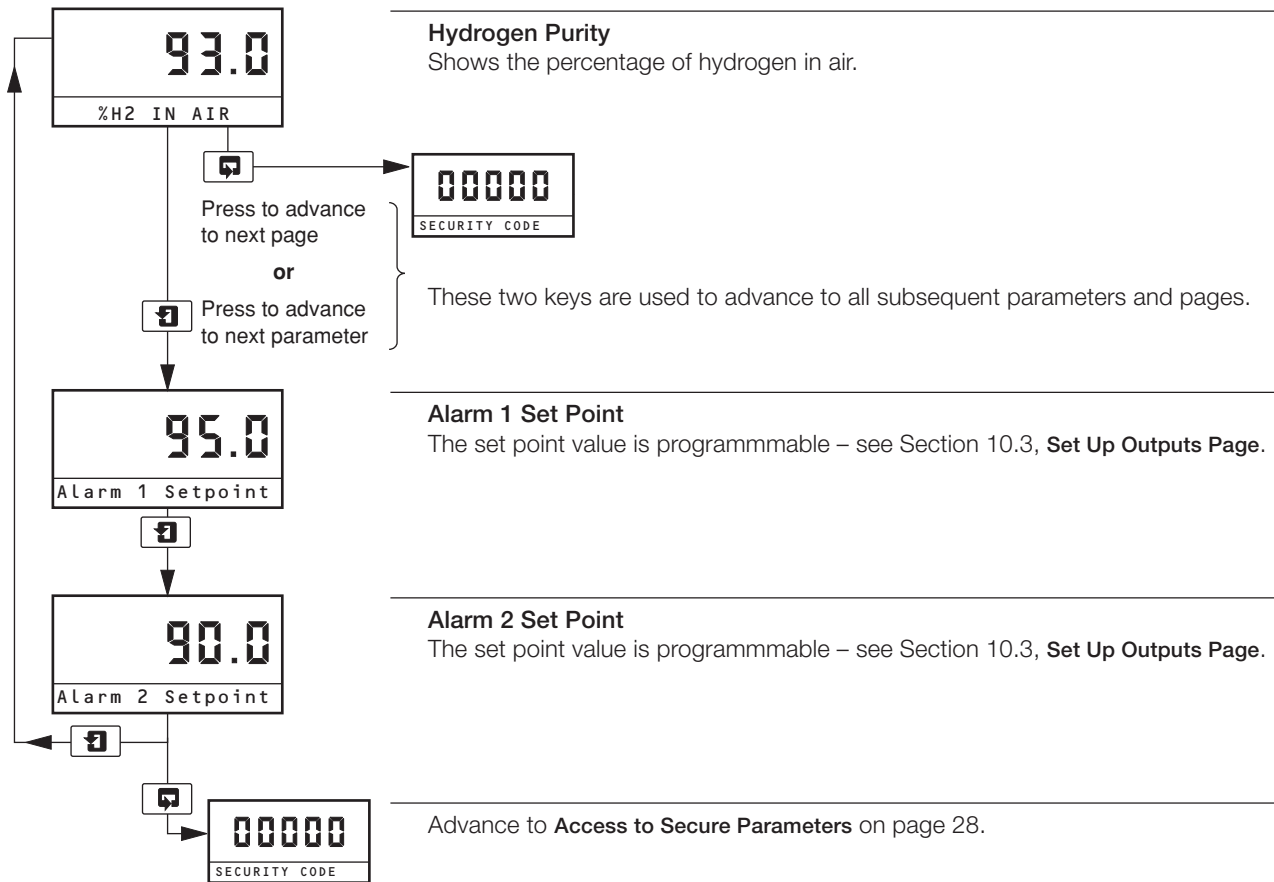

## 9.3 Range 2 Operating Page

Range 2 is selected only during purging and refilling operations and the **Operating Page** indicates the percentage of hydrogen in the CO<sub>2</sub> or Argon purge gas. Access to the programming pages is not possible with range 2 selected.



### Purge Gas

Shows the percentage of hydrogen in the CO<sub>2</sub> or Argon purge gas.

## 9.4 Range 3 Operating Page

Range 3 is selected only during purging and refilling operations and the **Operating Page** indicates the percentage of Air in the CO<sub>2</sub> or Argon purge gas. Access to the programming pages is not possible with range 3 selected.



### Purge Gas

Shows the percentage of Air in the CO<sub>2</sub> or Argon purge gas.

Notes.

- Access to the programming pages is possible only with Range 1 selected.
- The following programming pages apply to **both** display units.

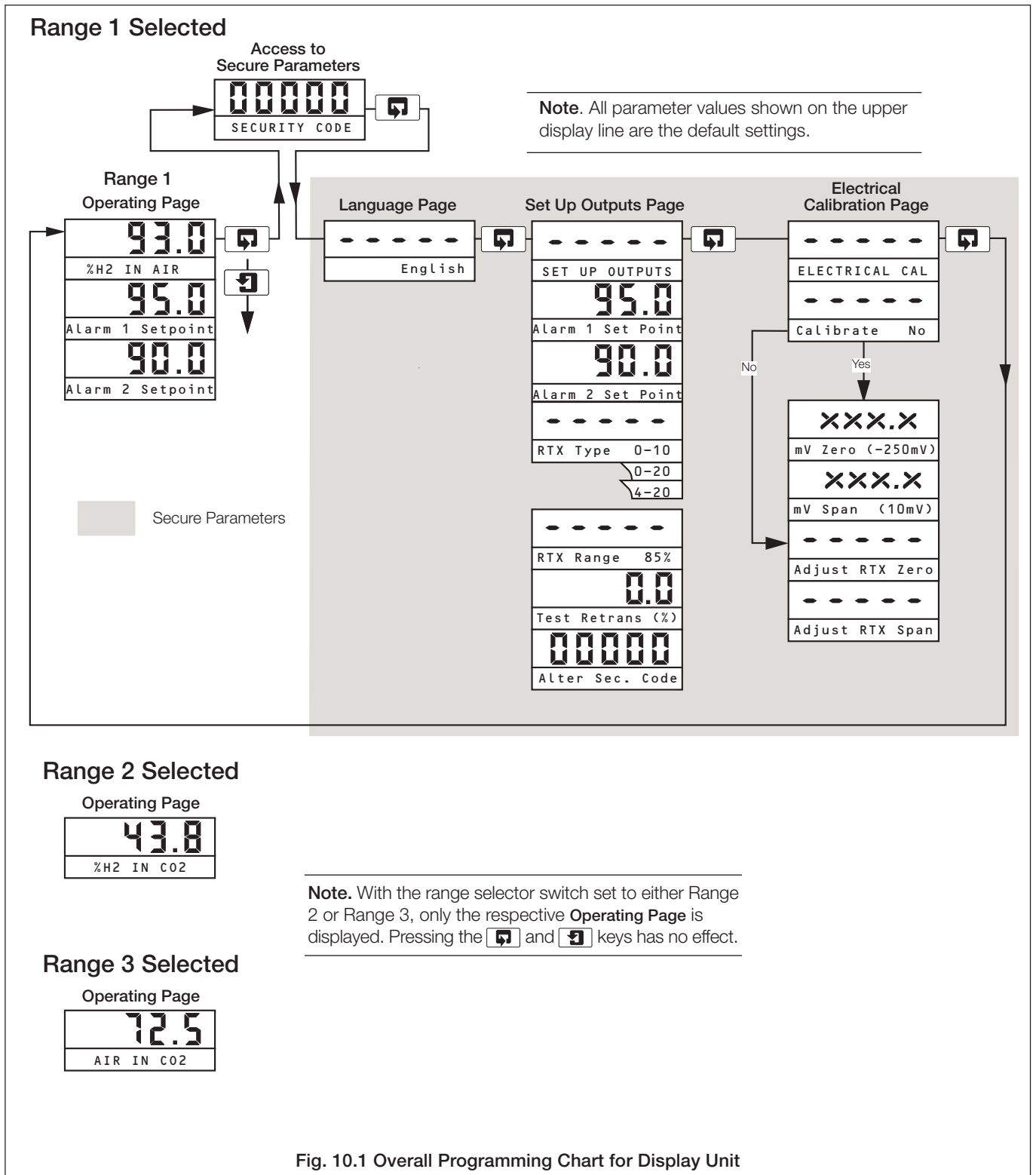
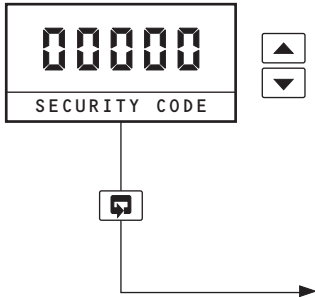

Fig. 10.1 Overall Programming Chart for Display Unit

## 10 PROGRAMMING

**Note.** Access to the programming pages is possible only with Range 1 selected.

**Note.** CO<sub>2</sub> is referred to throughout this manual as the purge gas. However, other gases such as Argon or Nitrogen may be used instead.



### 10.1 Access to Secure Parameters

A 5-digit code is used to prevent unauthorized access to the secure parameters.

#### Security Code

Enter the required code number, between 00000 and 19999, to gain access to the secure parameters. If an incorrect value is entered, access to subsequent programming pages is prevented and the display reverts to the **Operating Page**.

**Note.** The security code is preset at '00000' to allow access during commissioning but should be altered to a unique value, known only to authorized operators – see Alter Security Code parameter in Set Up Outputs Page.

Advance to **Language Page**.

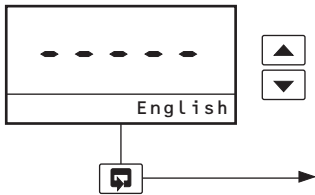

### 10.2 Language Page

#### Language Page

Select the required language for the display.

Advance to **Set Up Outputs Page**.

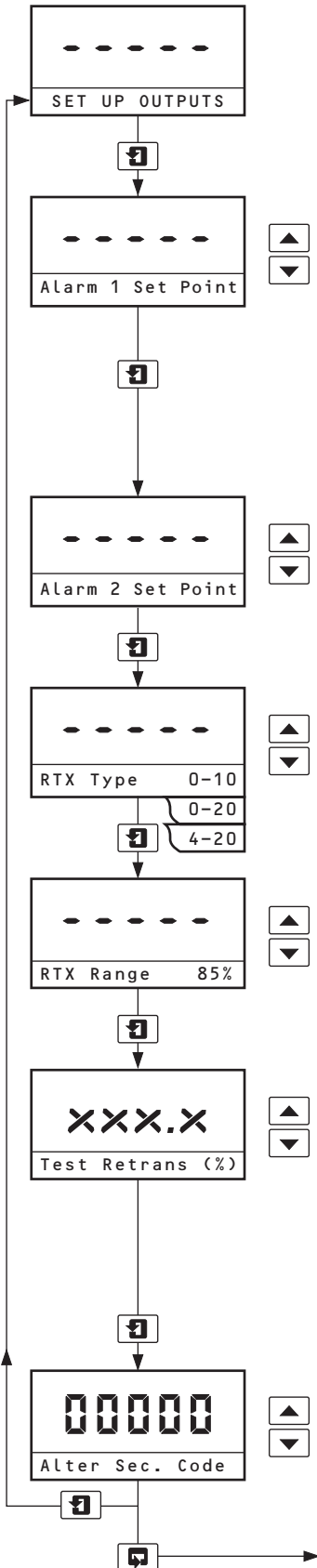

### 10.3 Set Up Outputs Page

**Note.** Access to the programming pages is possible only with Range 1 selected.

#### Alarm 1 Set Point

The set point band is defined as the actual value of the set point plus or minus the hysteresis value. The hysteresis value is fixed at 0.2% H<sub>2</sub> in Air. Alarm action occurs if the input value is above or below the set point band. If the input moves within the set point band, the last alarm action is maintained.

The **Alarm 1 Set Point** can be set to any value within the input range being displayed. The decimal point position is set automatically. The alarm LEDs are illuminated in the alarm condition.

#### Alarm 2 Set Point

See **Alarm 1 Set Point**.

Advance to next parameter

#### Retransmission Output Type

Select retransmission output range required (4 to 20mA, 0 to 20mA or 0 to 10mA).

Advance to next parameter

#### RTX Range

The retransmission signal can be selected to be ranged 85 to 100% H<sub>2</sub> in Air or 80 to 100% H<sub>2</sub> in Air. This option is only available with the range switch in position 1.

Advance to next parameter

#### Test Retransmission Output

The instrument transmits a test signal of 0, 25, 50, 75 or 100% of the retransmission range. The % test signal selected is shown on the upper line of the display.

**Example** – for the range 4 to 20mA and 50% retransmission test signal, 12mA is transmitted.

Select the required retransmission test signal.

Advance to next parameter

#### Alter Security Code

Set the security code to a value between 00000 and 19999.

This value will then have to be entered to regain access to the secure parameters.

10.4 Electrical Calibration Page

**Note.** Access to the programming pages is possible only with Range 1 selected.

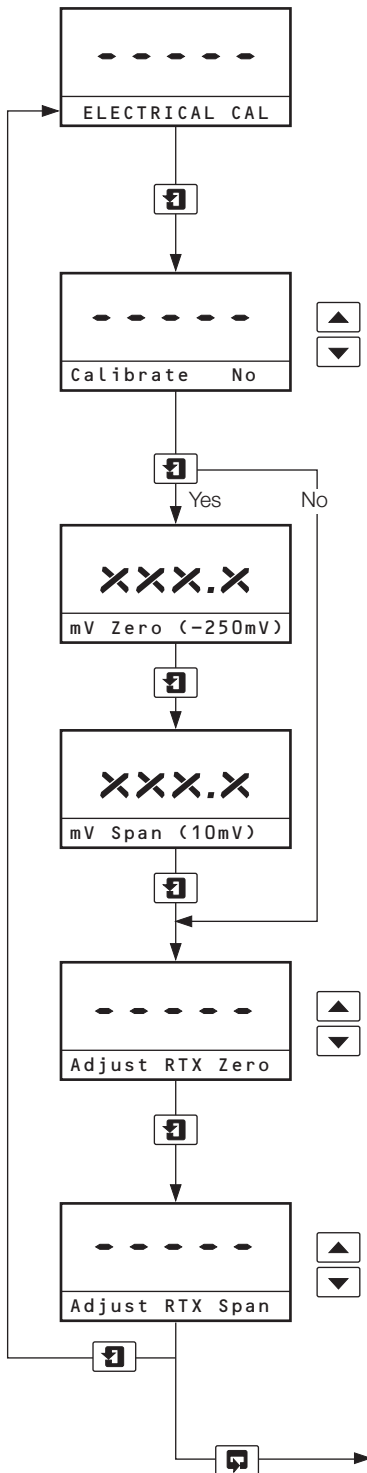

**Notes.**

- 1) The 4689 instruments incorporate a two point calibration sequence requiring both zero and span inputs for a calibration. It is not possible to adjust the range zero or the range span scale points independently.
- 2) The instruments are fully calibrated before despatch and should not normally require further calibration.

**Select Calibration**

Select the calibration requirement using the or keys.

**Calibrate No** (default) skips to Adjust RTX Zero frame.

**Calibrate Yes** enables zero and span electrical calibrations to be carried out. Advance to next parameter

**Calibration Range Zero (100% Purge Gas)**

Connect a suitable millivolt source (see Section 8.3) and apply a signal input equivalent to range zero (-250.00mV). Allow the instrument display to stabilize.

Advance to next parameter

**Calibration Range Span (100% H<sub>2</sub> in Air)**

Apply a signal input equivalent to range span (+10.00mV). Allow the instrument display to stabilize.

Advance to next parameter

**Adjust Retransmission Zero**

Adjust the retransmission zero (e.g. 4.00mA) to the appropriate zero value. The retransmission zero signal is either 85% or 80% H<sub>2</sub> in Air as selected in **Set Up Outputs Page**.

Allow the output signal to stabilize. Advance to next parameter

**Adjust Retransmission Span**

Adjust the retransmission span (e.g. 20.00mA) to the appropriate maximum value. The retransmission span signal corresponds to 100% H<sub>2</sub> in Air.

Allow the output signal to stabilize.

Return to **Operating Page**.

---

# 11 MAINTENANCE

---

The katharometer unit and its associated equipment are designed for stable and accurate operation over long periods.

This section covers the requirements for fault finding, diagnostic tests and maintenance tasks.

---

## Warning.

- Each unit of this system forms an integral part of a certified intrinsically safe system. Appropriate safety precautions must be taken to prevent any incendive electrical discharges in the hazardous area when carrying out any of the following tasks.
  - Equipment in this system operates at AC mains supply voltages. Suitable precautions must be taken to avoid the possibility of electric shock.
  - The maximum pressure and temperature limits specified for particular parts of the system must not be exceeded.
- 

## 11.1 General Maintenance

### 11.1.1 Pressure

The operation of the katharometer units is not affected significantly by changes in pressure providing that they are within the pressure limits – see Section 13.

### 11.1.2 Flow

The katharometer zero balance and sensitivity are independent of the sample flowrate, as the sample gas sensing system depends on molecular diffusion. However, the speed of response is affected by the flowrate. This means that the flow resistance of the drying chamber is a compromise between obtaining speed of response and avoiding a rapid degradation of the desiccant.

### 11.1.3 Leaks

There is an inherent safety requirement that there are no leaks into or out of the sample system. Any leaks could also affect the correct operation of the katharometer unit.

### 11.1.4 Vibration

The katharometer unit tolerates reasonable levels of mechanically induced vibration. Pulsations due to unsteady sample flow can affect the katharometer filaments and cause errors due to excessive cooling.

### 11.1.5 Contamination

Contamination in the sample system can arise from oil or suspended particles, or from erosion of material from the sample system upstream of the katharometer unit.

### 11.1.6 Ambient Temperature

The calibration of the katharometer is not affected significantly by variations of the ambient temperature. Temperature changes can affect the sensitivity and reduce accuracy on sensitive ranges.

### 11.1.7 Bridge Current

The working current of the katharometer bridge is 350mA supplied from the PSU. This value must remain stable during normal operation as the katharometer output signal is proportional to the cube of the bridge current.

## 11.2 Diagnostic Tests

---

### Warning.

- Each of the units in the system are part of the certified intrinsically safe system. Appropriate safety precautions must be taken to prevent any incendive electrical discharges in the hazardous area when carrying out this task.
  - Ensure that the proper electrical safety precautions are taken at all times when undertaking this procedure.
- 

### 11.2.1 Checking Output of the PSU

Carry out the test procedure in Section 6.3.1.

### 11.2.2 Checking Integrity of Zener Diode Safety Barrier Devices

Carry out the test procedure in Section 6.3.2.

### 11.2.3 Checking the Katharometer Output

- a) Electrically isolate the display unit.
- b) Remove the outer cover from the katharometer unit.
- c) With the katharometer operating, check if the voltage across terminals TB1 – 1 and TB1 – 4 is not above 4V with 350mA passing. If the voltage is above this value it is likely that one or more filaments of the bridge is broken.
- d) With the katharometer operating, check that the voltage across terminals TB1 – 1 and TB1 – 4 is below 2.8V with 350mA passing. If the voltage is below this value and there is no zero adjustment available, it is likely that there is an accumulation of liquid within the katharometer block – see Section 11.4.1.
- e) If the reading from the test made at step c) is unstable when the katharometer block is tapped gently, this could indicate that a filament is damaged but not open circuit.

If any of these tests indicate that the katharometer is faulty the complete katharometer unit must be returned for repair or replacement.

The span adjustment of katharometer units are sealed and must not be adjusted unless necessary – see Section 8.4.2.

## 11.3 Routine Maintenance

### 11.3.1 Hydrogen Katharometer Calibration

Carry out a calibration check in accordance with Section 8.

Calibration should be carried out at intervals of 3 months of on-line use.

### 11.3.2 Purge Gas Katharometer Calibration

Carry out a calibration check in accordance with Section 8.3.

Calibration should be carried out before using the katharometer for monitoring a purging procedure.

### 11.3.3 Changing Desiccant in Drying Chamber

The need to change the desiccant in the drying chamber on the katharometer Analyzer panel depends on the condition of the sample gas.

It is recommended that the Analyzer system is monitored regularly during the initial phase of operation for indications that the desiccant is exhausted. A suitable maintenance interval for this task can then be established.

As the desiccant degrades, the white grains have a yellowish tinge and the granular form becomes more consolidated. If liquid contamination occurs, the desiccant becomes brown and consolidated.

**Warning.** Suitable safety precautions apply to the operation of the gas cooling and sample systems.

- a) Isolate the sample gas system from the main system. Carry out a limited hydrogen purging operation on the sample system in accordance with the instructions of the responsible authority.
- b) Fill the drying chamber – see Section 6.1.
- c) After purging any residual air from the sample system in accordance with the requirements of the responsible authority, allow hydrogen to pass through the katharometer again.

This procedure should be undertaken on the basis of instrument response or at intervals of 1 year.

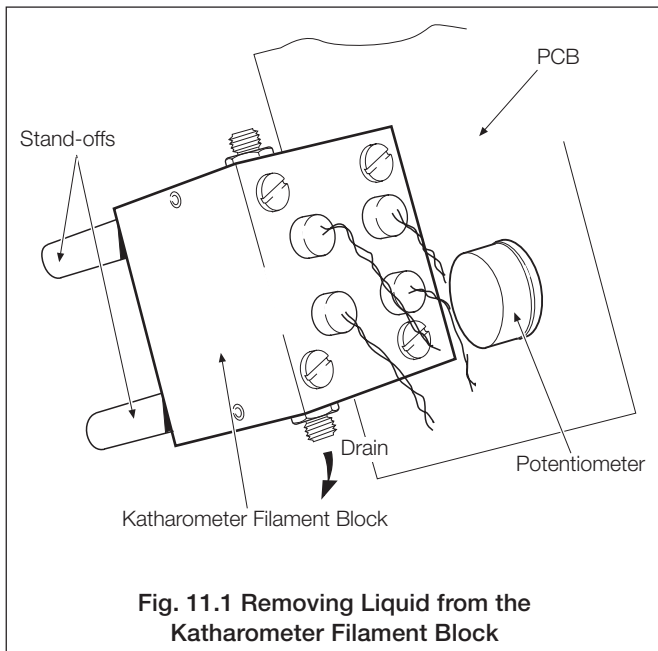

### 11.4 Repair Maintenance

#### 11.4.1 Removing Liquid from Katharometer Measurement Block – Fig. 11.1

If tests indicate that there is likely to be an accumulation of liquid in the katharometer filament block, remove the liquid using the following procedure:

- a) Electrically isolate the defective katharometer at its PSU.
- b) Isolate the gas sample system to the particular katharometer from the main gas cooling system. Purge the sample system of hydrogen in accordance with the requirements of the responsible authority.

**Caution.** The thermal insulation inside the case must not be damaged or removed.

- c) Remove the cover of the katharometer unit and dismantle the internal sample system pipework.
- d) Remove the fixing screws securing the mounting pillars to the case – see Fig. 5.5.
- e) Disconnect the interconnecting wiring at terminal block TB1.

**Caution.** Do not insert any type of probe into the gas system of the katharometer filament block assembly or use compressed air to blow through the system.

- f) Remove the katharometer filament block assembly from the case and tilt at 45° to the horizontal. This allows any liquid to drain from the measurement block – see Fig. 11.1.
- g) Pour a small quantity of rectified spirit (ethanol) through the katharometer filament block. Allow as much liquid as possible to drain out. Assist this by gentle shaking. Repeat this procedure several times until all evidence of contamination is removed.
- h) Fit the katharometer filament block assembly into its case. Replace the fixing screws and make the electrical interconnections at terminals TB1 – 1 and TB1 – 4.
- i) Fit the internal sample gas tubing.
- j) Remake the sample gas tube interconnection couplings.
- k) Replace the desiccant in the drying chamber in accordance with the procedure in Section 11.3.3.
- l) Carry out a leak test in accordance with the requirements of the responsible authority.
- m) Power up the katharometer unit by switching on the appropriate PSU.
- n) Pass dry air or another suitable dry gas through the katharometer at the normal sample flowrate for 24 hours.

Continued...

- o) Isolate the katharometer unit at its PSU.
- p) Make the remaining electrical connections at TB1 of the katharometer unit – see Fig. 5.5 on page 17.
- q) Replace the cover of the katharometer unit.
- r) Power up the katharometer unit from its PSU.
- s) Carry out a calibration procedure – see Section 8.3.

**Note.** It is possible that the zero reading may drift for several days after the removal of liquid.

**11.4.2 Removal/Replacement of a Display Unit**

- a) Electrically isolate the 6553 Display Unit.
- b) Release the retaining screw through the display facia and carefully withdraw the chassis from its edge connectors and out through the front panel – see Fig. 3.1 on page 5.
- c) To replace the unit, carefully insert it into the display facia and press firmly into position before tightening the retaining screw.
- d) Power up the display unit and carry out a calibration – see Section 8.3.

**11.4.3 Error Messages**

If the error message 'NV Memory Error' is displayed the contents of the non-volatile memory has not been read correctly during power up.

To rectify the fault, switch off, wait 10 seconds and switch on again. If the fault persists, contact the Company.

**Warning.** Interference with any unit or its components implies acceptance of responsibility by that person for ensuring the continuing maintenance of intrinsic safety requirements. Unauthorized repair/ use of spare parts or incorrect assembly may render any unit unfit for use in an intrinsically safe application.

**Note.** Although the digital display units may be marked 4600 on their display facia, they are dedicated variants which are not interchangeable with the Company's standard 4600 Controller/Display. These dedicated display units are identified (4689 502) as shown in Fig. 3.1 on page 5.

When ordering a katharometer unit, it is necessary to specify the zero gas and range in association with the Company part number. See the typical identification label shown in Fig. 3.2 on page 5.

**12.1 Consumables**

Description	Part No.
<b>Model 006548 000 &amp; 006548 203</b>	
<b>Katharometer Analyzer Panels</b>	
Granular anhydrous CaCl <sub>2</sub>	Sourced locally

**12.2 Routine Maintenance Parts**

Description	Part No.
<b>Model 6553 Display Unit</b>	
Fuse, 500mA a/s 20 x 5 mm glass cartridge	0231 538
Function selector switch, 3 position, 2 wafer	0234 724
Potentiometer (1k ), zer o adjustment	002569 036
<b>Katharometer Analyzer Panel</b>	<b>006540 203 006548 000</b>
Seal, top of drying chamber	002310 012 002310 012
Seal, bottom of drying chamber	006519 160 0211 035
Gauze, drying chamber	006525 700 006548 018

**12.3 Repair Maintenance Parts**

Description	Part No.
<b>Model 4234 Power Supply Unit</b>	
Nominal 230V unit	4234 500
Nominal 115V unit	4234 501
Fuses	
F2/F3 – 250mA/ 1500A HBC cartridge	0231577
F1 – 400mA cartridge	0231555
<b>Katharometer Analyzer Panel</b>	<b>006540 203 006548 000</b>
Flowmeter	006525 460 0216 485
Valve, metering	006540 361 0216 484
Coupling seal ring	006525 130
<b>Katharometer unit</b>	006539 960K (or J)
006548 001	
<b>Model 6553 Display Unit</b>	
Display units (H <sub>2</sub> /CO <sub>2</sub> )	4689 502
Display units (H <sub>2</sub> /Ar)	4689 505
Zener diode safety barrier devices MTL 7055ac	0248 297
Zener diode safety barrier devices MTL 7755ac	0248 296

# 13 SPECIFICATION

## 6553 Gas Monitor

### Approvals

CENELEC approved  
EEx ia IIC T<sub>amb</sub> -20°C to +40°C  
BASEEFA Certificate No. BAS 01 ATEX 7043  
II (1)G

### Ranges

- (a) 80% or 85% to 100% H<sub>2</sub> in air
- (b) 0 to 100% H<sub>2</sub> in CO<sub>2</sub> \*
- (c) 0 to 100% air in CO<sub>2</sub> \*

### Range Selector Switch Positions (when fitted)

- 1 – percentage by volume, hydrogen in air
- 2 – percentage by volume, hydrogen in carbon dioxide
- 3 – percentage by volume, air in carbon dioxide

### Accuracy (display units)

± 0.25% of scale span

### Ambient Temperature Range

0 to 45°C (32 to 113°F)

### Power Supply

110/120V AC or 200/220/240V AC, 50/60Hz  
(two separate versions)

### Power Consumption

30VA approximately

### Outline Dimensions

290 x 362 x 272mm (11.4 x 14.25 x 10.9 in.)

### Weight

12kg (26.4lb)

### Environment

Sheltered interior, 0 to 90% RH

## Outputs and Set Points

### No. of relays

- AK101 – Three (Two for H<sub>2</sub> Purity, One for Purge Gas)
- AK102 – Four (H<sub>2</sub> Purity)
- AK103 – Two (H<sub>2</sub> Purity)
- AK104 – Two (H<sub>2</sub> Purity)

### Relay contacts

Single pole changeover		
	Rating	250V AC    250V DC max.
		3A AC        3A DC max.
	Loading (non-inductive)	750VA      30W max.
	(inductive)	75VA        3W max.

### Insulation

2kV RMS contacts to earth (ground)

### Remote range indication

Rating	250V AC	300V AC max.
	150mA AC	150mA AC max.

### No. of set points

- AK101 – Three (Two for H<sub>2</sub> Purity, One for Purge Gas)
- AK102 – Four (H<sub>2</sub> Purity)
- AK103 – Two (H<sub>2</sub> Purity)
- AK104 – Two (H<sub>2</sub> Purity)

### Set point adjustment

Programmable

### Set point hysteresis

±1% fixed

### Local set point annunciation

Red LED

---

## Retransmission

### No. of retransmission signals

- AK101 – Two fully isolated (One for H<sub>2</sub> Purity, One for Purge Gas)
- AK102 – Two fully isolated
- AK103 – One fully isolated
- AK104 – One fully isolated (H<sub>2</sub> Purity)

### Output current

0 to 10mA, 0 to 20mA or 4 to 20mA programmable

### Accuracy

±0.25% FSD ±0.5% reading

### Resolution

0.1% at 10mA, 0.05% at 20mA

### Max. load resistance

750Ω (20mA max.)

\* CO<sub>2</sub> standard option  
Ar or N<sub>2</sub> also available

**4234 Power Supply Unit****Approvals**

CENELEC approved  
[EEx ia] IIC T<sub>amb</sub> -20°C to +55°C

BAS EEF A Certificate No. BAS 01 ATEX 7041  
⊕ II (1)G

**Input Voltage**

115V AC 50/60Hz (4234501) or  
230V AC 50/60Hz (4234500)

**Fuse Rating**

250mA HRC ceramic

**DC Output**

350mA stabilized  $\pm 0.14\%$

**Load Conditions**

1 Katharometer 13 $\Omega$  max.  
Interconnecting cable 2 $\Omega$  max.

**Ambient Temperature Range**

-20 to 55°C (-4 to 131°F)

**Supply Variations**

$\pm 15V$  (115V supply) or  $\pm 30V$  (230V supply) 46 to 64Hz

**Regulation**

Within  $\pm 0.5\%$  for:

Load variation of  $\pm 15\%$

Supply variation of  $\pm 15\%$

Ambient temperature variation of  $\pm 20^\circ\text{C}$  (36°F)

$\pm 4\text{Hz}$  frequency variation

**Ripple**

Less than 0.5% of set output peak/peak across  
a 10 $\Omega$  load

**Stability**

Within  $\pm 0.7\%$  of initial setting, over period of 1 month with load  
resistance, supply voltage and ambient temperature at nominal  
stated values

**Overall Dimensions**

160 x 170 x 110mm (6.3 x 6.7 x 4.3 in.)

**Weight**

2.12kg (4.8 lb) approx.

**Environment**

Sheltered interior

**Note.**

Variations to the earlier certificate (SFA 3012:1972) allow the use of  
these items in systems supplied to that standard.

**6540-203 and 6548-000  
Katharometer Analyzer Panel****Approvals**

CENELEC approved  
EEx ia IIC T<sub>amb</sub> -20°C to +55°C

BAS EEF A Certificate No. BAS 01 ATEX 1042  
⊕ II (1)G

**Model 6540-203** incorporating Model 6539-960 (H<sub>2</sub>) or  
Model 6539-960 (CO<sub>2</sub>) Katharometer Unit

**Model 6548-000** incorporating Model 6548-001  
(H<sub>2</sub> and CO<sub>2</sub>) Katharometer Unit

**Power Supply**

350mA DC, from 4234500 or 4234501 power supply unit

**Signal Output**

0 to 10mV for each range

**Accuracy**

$\pm 2\%$  of scale span, each range

**Dead Time**

Typically 5s

**Response Time**

Typically 40s for 90% step change at Katharometer  
Tubing and drying chamber introduce extra delays

**Ambient Temperature**

55°C (131°F) max.

**Sample Connections**

Compression couplings:  
6mm OD tube (Model 6548-000)  
8mm OD tube (Model 6540-203)

**Sample Pressure**

Minimum 125mm H<sub>2</sub>O  
Maximum 0.35bar (Gauge) Model 6540-203  
Maximum 10bar (Gauge) Model 6548-000

**Normal Sample Flowrate**

100 to 150ml/min.

**Maximum Gas Flowrate**

250ml/min

**Minimum Gas Flowrate**

50ml/min

**Outline Dimensions**

610 x 305 x 152mm (24 x 12 x 6 in.)

**Weight**

8.6kg (18.9lb)

**Environment**

Sheltered interior

---

## NOTES

---

# PRODUCTS & CUSTOMER SUPPORT

## Products

### Automation Systems

- *for the following industries:*
  - Chemical & Pharmaceutical
  - Food & Beverage
  - Manufacturing
  - Metals and Minerals
  - Oil, Gas & Petrochemical
  - Pulp and Paper

### Drives and Motors

- *AC and DC Drives, AC and DC Machines, AC motors to 1kV*
- *Drive systems*
- *Force Measurement*
- *Servo Drives*

### Controllers & Recorders

- *Single and Multi-loop Controllers*
- *Circular Chart, Strip Chart and Paperless Recorders*
- *Paperless Recorders*
- *Process Indicators*

### Flexible Automation

- *Industrial Robots and Robot Systems*

### Flow Measurement

- *Electromagnetic Flowmeters*
- *Mass Flow Meters*
- *Turbine Flowmeters*
- *Flow Elements*

### Marine Systems & Turbochargers

- *Electrical Systems*
- *Marine Equipment*
- *Offshore Retrofit and Refurbishment*

### Process Analytics

- *Process Gas Analysis*
- *Systems Integration*

### Transmitters

- *Pressure*
- *Temperature*
- *Level*
- *Interface Modules*

### Valves, Actuators and Positioners

- *Control Valves*
- *Actuators*
- *Positioners*

### Water, Gas & Industrial Analytics Instrumentation

- *pH, conductivity, and dissolved oxygen transmitters and sensors*
- *ammonia, nitrate, phosphate, silica, sodium, chloride, fluoride, dissolved oxygen and hydrazine analyzers.*
- *Zirconia oxygen analyzers, katharometers, hydrogen purity and purge-gas monitors, thermal conductivity.*

## Customer Support

We provide a comprehensive after sales service via a Worldwide Service Organization. Contact one of the following offices for details on your nearest Service and Repair Centre.

### United Kingdom

ABB Limited  
Tel: +44 (0)1453 826661  
Fax: +44 (0)1453 829671

### United States of America

ABB Inc.  
Tel: +1 775 850 4800  
Fax: +1 775 850 4808

#### Client Warranty

Prior to installation, the equipment referred to in this manual must be stored in a clean, dry environment, in accordance with the Company's published specification.

Periodic checks must be made on the equipment's condition. In the event of a failure under warranty, the following documentation must be provided as substantiation:

1. A listing evidencing process operation and alarm logs at time of failure.
2. Copies of all storage, installation, operating and maintenance records relating to the alleged faulty unit.

---

**ABB** has Sales & Customer Support  
expertise in over 100 countries worldwide

[www.abb.com](http://www.abb.com)

The Company's policy is one of continuous product  
improvement and the right is reserved to modify the  
information contained herein without notice.

Printed in UK (05.05)

© ABB 2005



**ABB Limited**  
Oldends Lane, Stonehouse  
Gloucestershire  
GL10 3TA  
UK  
Tel: +44 (0)1453 826661  
Fax: +44 (0)1453 829671

**ABB Inc.**  
Analytical Instruments  
9716 S. Virginia St., Ste. E  
Reno, Nevada 89521  
USA  
Tel: +1 775 850 4800  
Fax: +1 775 850 4808