

AX413, AX430, AX433, AX436 & AX438

Single and dual input analyzers for high level conductivity



The Company

We are an established world force in the design and manufacture of measurement products for industrial process control, flow measurement, gas and liquid analysis and environmental applications.

As a part of ABB, a world leader in process automation technology, we offer customers application expertise, service and support worldwide.

We are committed to teamwork, high quality manufacturing, advanced technology and unrivalled service and support.

The quality, accuracy and performance of the Company's products result from over 100 years experience, combined with a continuous program of innovative design and development to incorporate the latest technology.

EN ISO 9001:2000



Cert. No. Q 05907

EN 29001 (ISO 9001)



Lenno, Italy – Cert. No. 9/90A

Stonehouse, U.K.



Electrical Safety

This equipment complies with the requirements of CEI/IEC 61010-1:2001-2 'Safety Requirements for Electrical Equipment for Measurement, Control and Laboratory Use'. If the equipment is used in a manner NOT specified by the Company, the protection provided by the equipment may be impaired.

Symbols

One or more of the following symbols may appear on the equipment labelling:

	Warning – Refer to the manual for instructions
	Caution – Risk of electric shock
	Protective earth (ground) terminal
	Earth (ground) terminal

	Direct current supply only
	Alternating current supply only
	Both direct and alternating current supply
	The equipment is protected through double insulation

Information in this manual is intended only to assist our customers in the efficient operation of our equipment. Use of this manual for any other purpose is specifically prohibited and its contents are not to be reproduced in full or part without prior approval of the Technical Publications Department.

Health and Safety

To ensure that our products are safe and without risk to health, the following points must be noted:

1. The relevant sections of these instructions must be read carefully before proceeding.
2. Warning labels on containers and packages must be observed.
3. Installation, operation, maintenance and servicing must only be carried out by suitably trained personnel and in accordance with the information given.
4. Normal safety precautions must be taken to avoid the possibility of an accident occurring when operating in conditions of high pressure and/or temperature.
5. Chemicals must be stored away from heat, protected from temperature extremes and powders kept dry. Normal safe handling procedures must be used.
6. When disposing of chemicals ensure that no two chemicals are mixed.

Safety advice concerning the use of the equipment described in this manual or any relevant hazard data sheets (where applicable) may be obtained from the Company address on the back cover, together with servicing and spares information.

CONTENTS

Section	Page	Section	Page
1 INTRODUCTION	2	6 INSTALLATION	42
1.1 System Description	2	6.1 Siting Requirements	42
1.2 PID Control – AX430 Analyzer Only	2	6.2 Mounting	43
1.3 AX400 Series Analyzer Options	2	6.2.1 Wall-/Pipe-mount Analyzers	43
2 OPERATION	3	6.2.2 Panel-mount Analyzers	44
2.1 Powering Up the Analyzer	3	6.3 Electrical Connections	45
2.2 Displays and Controls	3	6.3.1 Relay Contact Protection and Interference Suppression	46
2.2.1 Membrane Key Functions	3	6.3.2 Cable Entry Knockouts, Wall-/Pipe-mount Analyzer	47
2.3 Operating Page	6	6.4 Wall-/Pipe-mount Analyzer Connections	48
2.3.1 Single Input 4-Electrode Conductivity	6	6.4.1 Access to Terminals	48
2.3.2 Dual Input 4-Electrode Conductivity	7	6.4.2 Connections	49
3 OPERATOR VIEWS	8	6.5 Panel-mount Analyzer Connections	50
3.1 View Set Points	8	6.5.1 Access to Terminals	50
3.2 View Outputs	9	6.5.2 Connections	51
3.3 View Hardware	9	7 CALIBRATION	52
3.4 View Software	10	7.1 Equipment Required	52
3.5 View Logbook	10	7.2 Preparation	52
3.6 View Clock	12	7.3 Factory Settings	53
4 SETUP	13	8 SIMPLE FAULT FINDING	59
4.1 Sensor Calibration	13	8.1 Error Messages	59
5 PROGRAMMING	15	8.2 No Response to Conductivity Changes	59
5.1 Security Code	15	8.3 Checking the Temperature Input	59
5.2 Configure Display	16	SPECIFICATION	60
5.3 Configure Sensors	17	APPENDIX A	62
5.4 Configure Alarms	24	A1 Automatic Temperature Compensation	62
5.4.1 Configure Standard Alarms	24	A1.1 Calculation of Temperature Coefficient	62
5.4.2 Configure CIP Interface Alarm	26	APPENDIX B	63
5.4.3 Configure CIP Status Alarm	28	B1 Single PID Controller	63
5.4.3 Configure CIP Status Alarm	29	B1.1 Reverse Acting Single PID Control	63
5.5 Configure Outputs	31	B1.2 Direct Acting Single PID Control	64
5.6 Configure Clock	33	B2 Output Assignment	64
5.7 Configure Control	34	B3 Setting Up Three Term (PID) Control Parameters ...	65
5.7.1 Configure Single PID Controller	35	B4 Manual Tuning	65
5.7.2 Configure Power Failure Recovery Mode	38		
5.8 Configure Security	39		
5.9 Configure Logbook	39		
5.10 Test Outputs and Maintenance	40		

1 INTRODUCTION

1.1 System Description

The AX430 Single Input and AX433 Dual Input, 4-electrode Conductivity analyzers have been designed for continuous monitoring and control of high level conductivity.

They are available in wall-/pipe-mount or panel-mount versions and can be used with either one or two sensors, each with a temperature input channel. When used with two sensors, readings can be compared to produce a range of extrapolated values.

When making temperature compensated measurements, the sample temperature is sensed by a resistance thermometer (Pt1000 or Balco 3K) mounted in the measuring cell.

Analyzer operation and programming are performed using five tactile membrane keys on the front panel. Programmed functions are protected from unauthorized alteration by a five-digit security code.

1.2 PID Control – AX430 Analyzer Only

The AX430 single input 4-electrode conductivity analyzer incorporates Proportional Integral Derivative (PID) control as standard. For a full description of PID control, refer to Appendix B.

1.3 AX400 Series Analyzer Options

Table 1.1 shows the range of configurations that are possible for the AX400 Series analyzers. The analyzer detects the type of input board fitted for each input automatically and displays only the operating and programming frames applicable to that input board type. If no input board is fitted for a second input (Sensor B), Sensor B frames are not displayed.

Model	Analyzer Description	Sensor A	Sensor B
AX410	Single Input 2-Electrode Conductivity (0 to 10,000 $\mu\text{S}/\text{cm}$)	2-Electrode Conductivity	Not Applicable
AX411	Dual Input 2-Electrode Conductivity (0 to 10,000 $\mu\text{S}/\text{cm}$)	2-Electrode Conductivity	2-Electrode Conductivity
AX413	Dual Input 2-Electrode Conductivity and 4-Electrode Conductivity	2-Electrode Conductivity	4-Electrode Conductivity
AX416	Dual Input 2-Electrode Conductivity and pH/Redox(ORP)	2-Electrode Conductivity	pH/Redox(ORP)
AX418	Dual Input 2-Electrode Conductivity and Dissolved Oxygen	2-Electrode Conductivity	Dissolved Oxygen
AX430	Single Input 4-Electrode Conductivity (0 to 2,000 mS/cm)	4-Electrode Conductivity	Not Applicable
AX433	Dual Input 4-Electrode Conductivity (0 to 2,000 mS/cm)	4-Electrode Conductivity	4-Electrode Conductivity
AX436	Dual Input 4-Electrode Conductivity and pH/Redox(ORP)	4-Electrode Conductivity	pH/Redox(ORP)
AX438	Dual Input 4-Electrode Conductivity and Dissolved Oxygen	4-Electrode Conductivity	Dissolved Oxygen
AX450	Single Input 2-Electrode Conductivity (USP)	2-Electrode Conductivity	Not Applicable
AX455	Dual Input 2-Electrode Conductivity (USP)	2-Electrode Conductivity	2-Electrode Conductivity
AX456	Dual Input 2-Electrode Conductivity (USP) and pH/Redox(ORP)	2-Electrode Conductivity	pH/Redox(ORP)
AX460	Single Input pH/Redox(ORP)	pH/Redox(ORP)	Not Applicable
AX466	Dual Input pH/Redox(ORP)	pH/Redox(ORP)	pH/Redox(ORP)
AX468	Dual Input pH/Redox(ORP) and Dissolved Oxygen	pH/Redox(ORP)	Dissolved Oxygen
AX480	Single Input Dissolved Oxygen	Dissolved Oxygen	Not Applicable
AX488	Dual Input Dissolved Oxygen	Dissolved Oxygen	Dissolved Oxygen

Table 1.1 AX400 Series Analyzer Options

2 OPERATION

2.1 Powering Up the Analyzer



Warning. Ensure all connections are made correctly, especially to the earth stud – see Section 6.3.

- 1) Ensure the input sensor(s) is/are connected correctly.
- 2) Switch on the power supply to the analyzer. A start-up screen is displayed while internal checks are performed, then the *Operating Page* (Section 2.3) is displayed as the conductivity monitoring operation starts.

2.2 Displays and Controls – Fig. 2.1

The display comprises two rows of 4½ digit, 7-segment digital displays, that show the actual values of the measured parameters and alarm set points, and a 6-character dot matrix display showing the associated units. The lower display line is a 16-character dot matrix display showing operating and programming information.

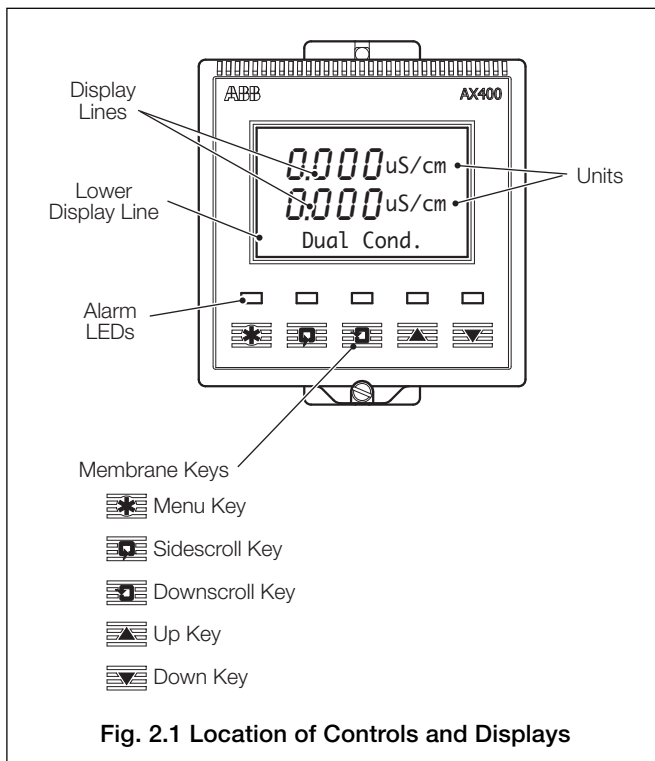

2.2.1 Membrane Key Functions – Fig. 2.2

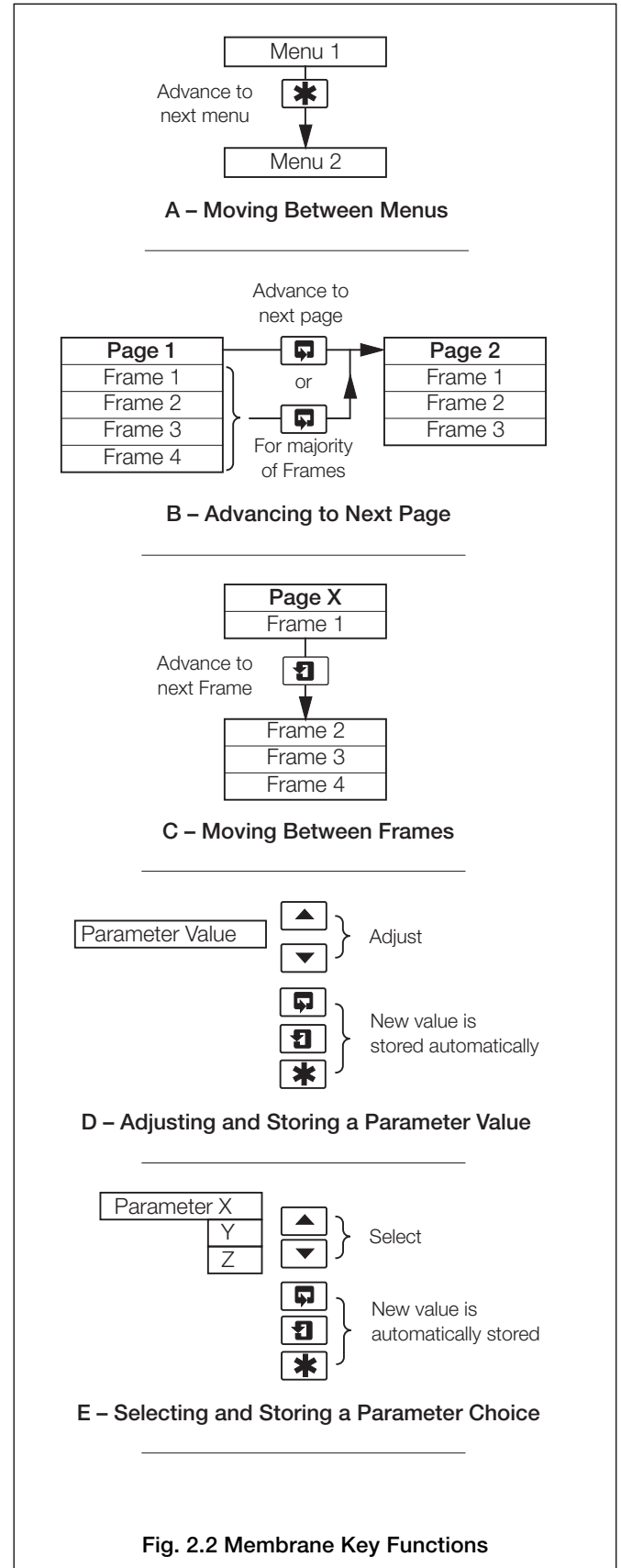

Fig. 2.2 Membrane Key Functions

...2 OPERATION

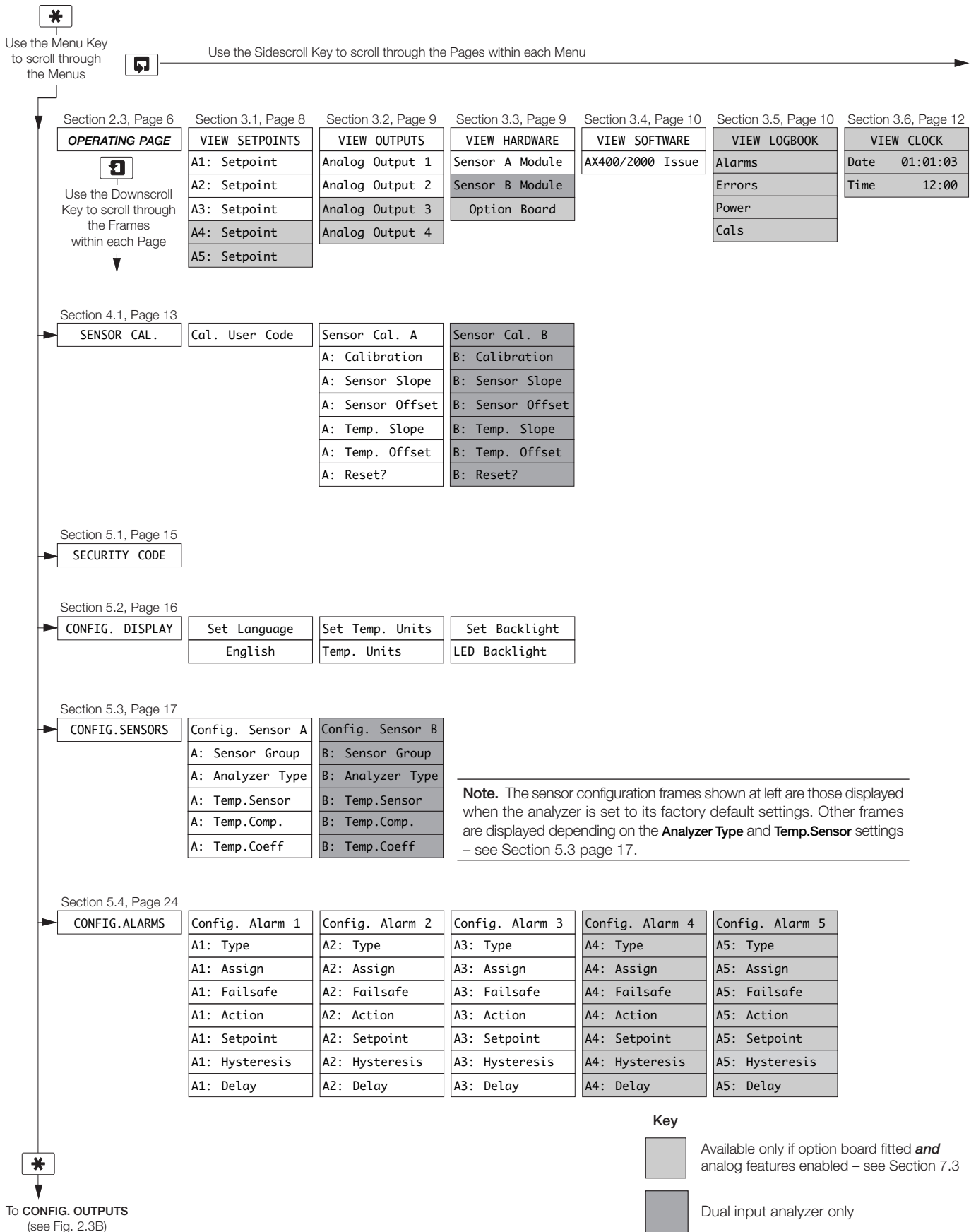

Fig. 2.3A Overall Programming Chart

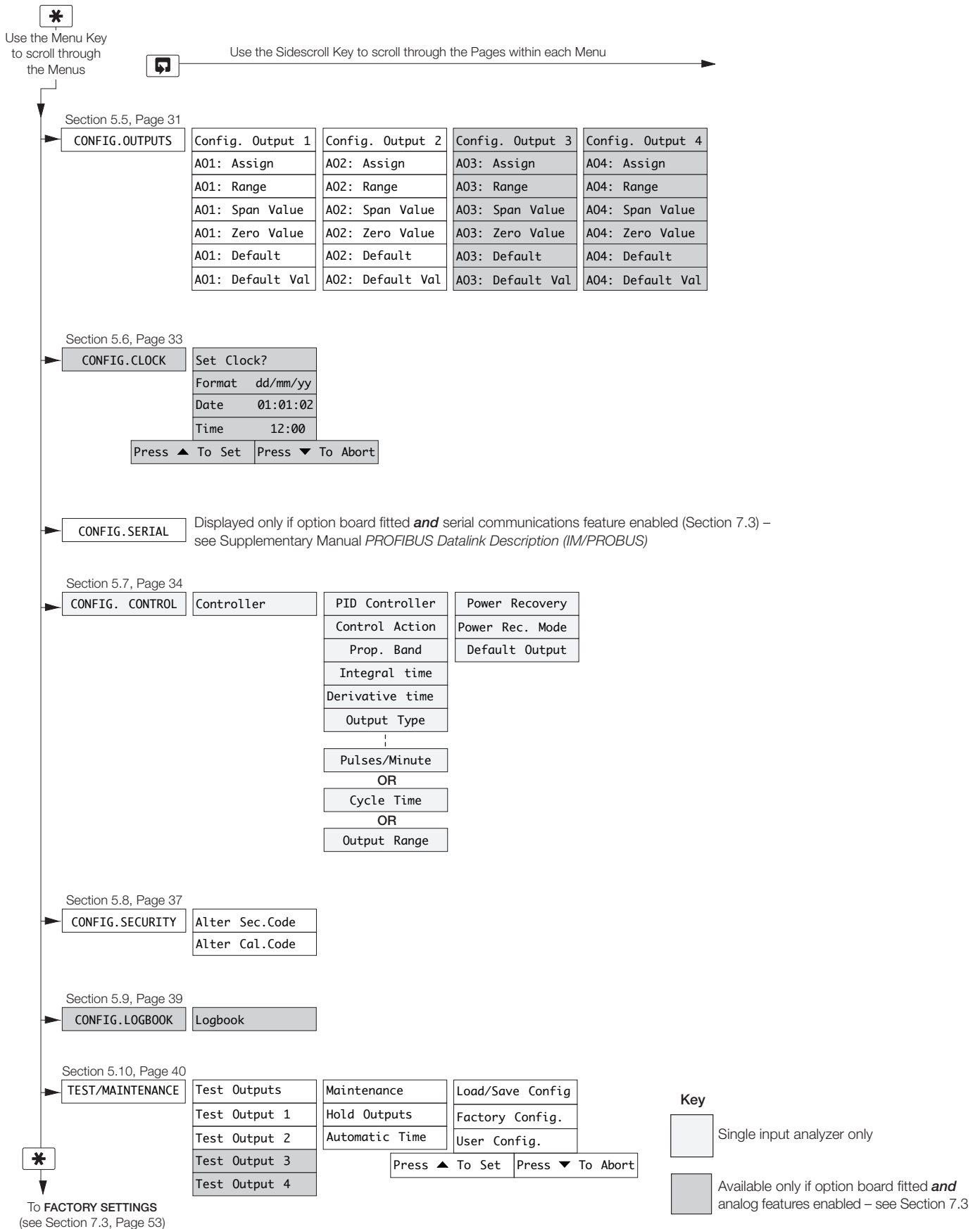
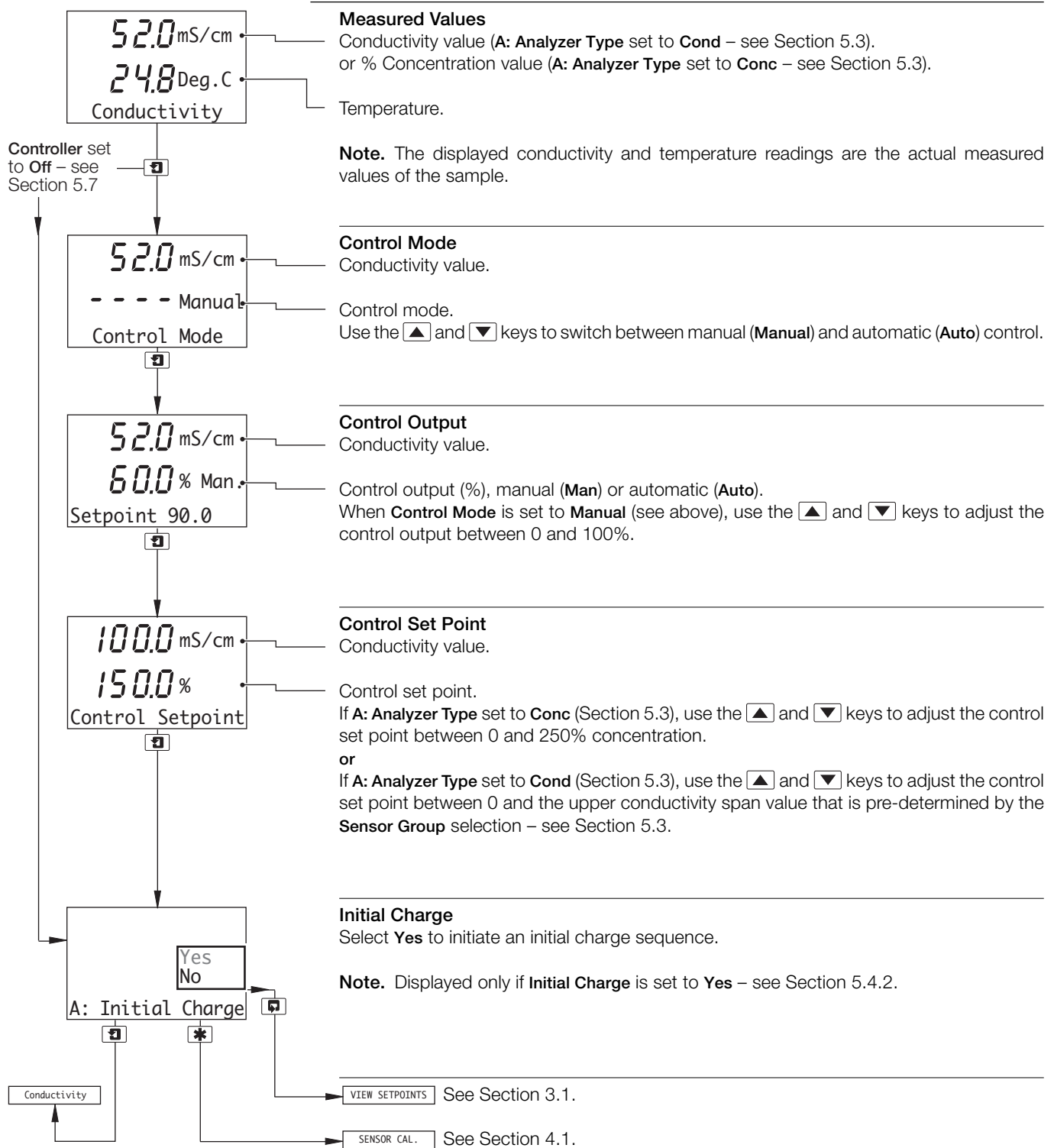

Fig. 2.3B Overall Programming Chart

2.3 Operating Page

2.3.1 Single Input 4-Electrode Conductivity



...2.3 Operating Page

2.3.2 Dual Input 4-Electrode Conductivity

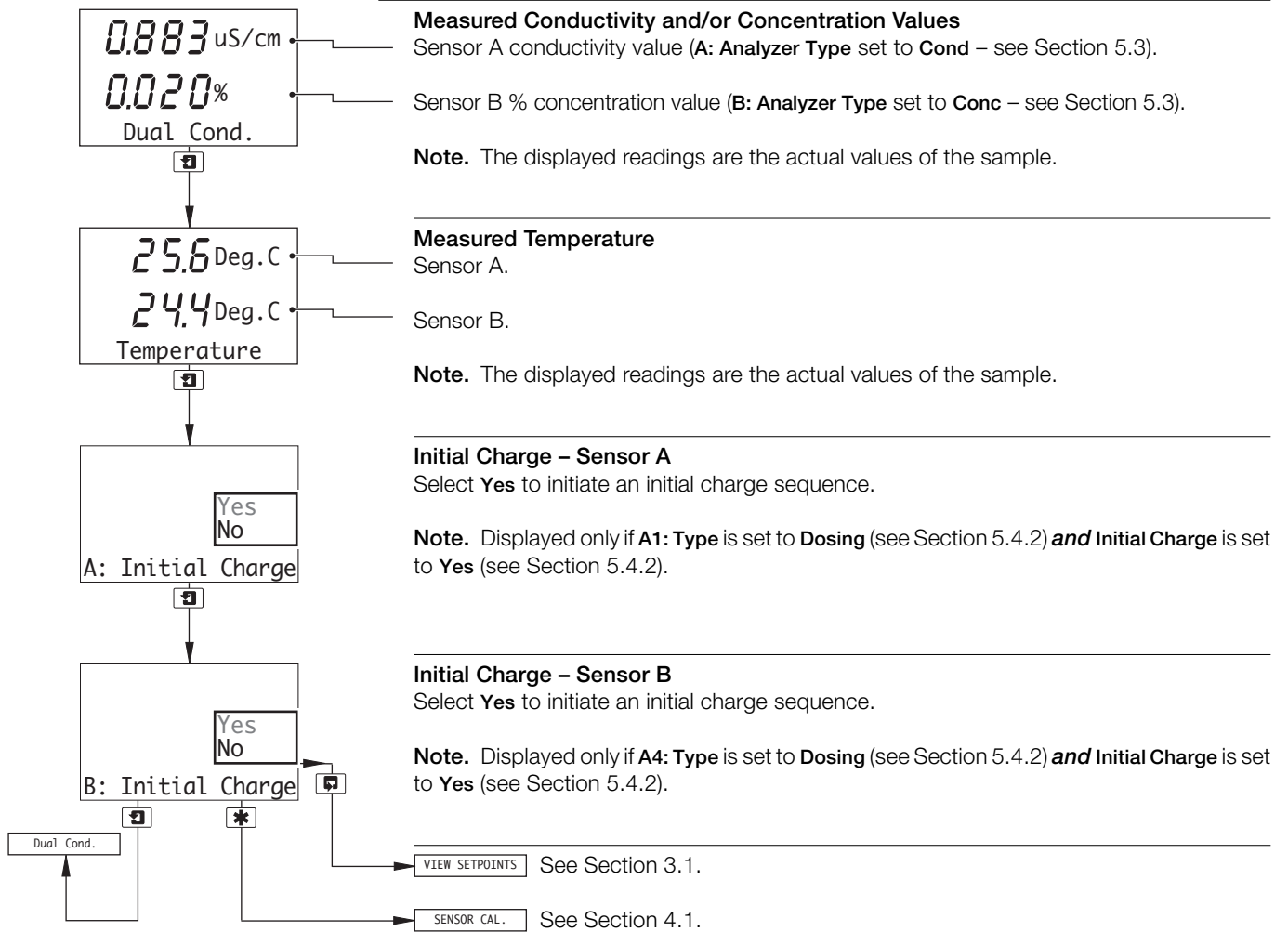

3 OPERATOR VIEWS

3.1 View Set Points

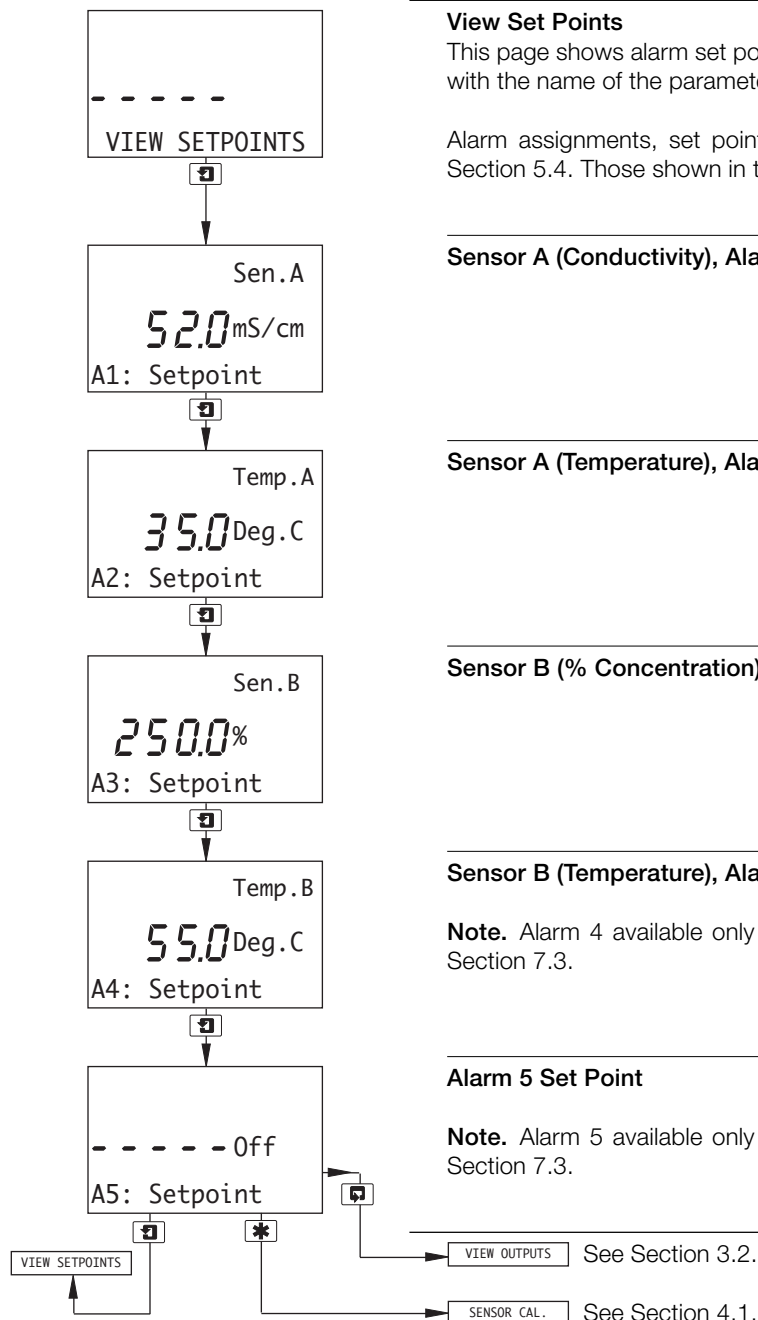

View Set Points

This page shows alarm set points. The value of each of the set points is shown, together with the name of the parameter it's assigned to.

Alarm assignments, set point values and relay/LED actions are programmable – see Section 5.4. Those shown in the following frames are examples only.

Sensor A (Conductivity), Alarm 1 Set Point

Sensor A (Temperature), Alarm 2 Set Point

Sensor B (% Concentration), Alarm 3 Set Point – Dual input analyzers only

Sensor B (Temperature), Alarm 4 Set Point – Dual input analyzers only

Note. Alarm 4 available only if option board fitted *and* analog features enabled – see Section 7.3.

Alarm 5 Set Point

Note. Alarm 5 available only if option board fitted *and* analog features enabled – see Section 7.3.

3.2 View Outputs

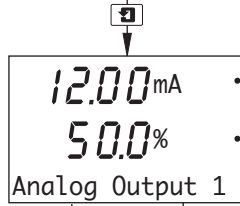
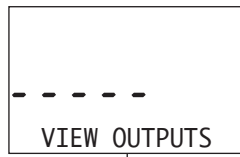

Theoretical Analog Output

There are up to four analog outputs, each showing information for one sensor.

Note. Analog outputs 3 and 4 available only if option board fitted **and** analog features enabled – see Section 7.3.

Live current output value being retransmitted.

Current output shown as a percentage of full scale for the output range set in **CONFIG. OUPUTS** – see Section 5.5.

VIEW HARDWARE See Section 3.3.

SENSOR CAL. See Section 4.1.

Analog Output 2 Advance to analog output 2 (and outputs 3 and 4 if option board fitted **and** analog features enabled – see Section 7.3).

3.3 View Hardware

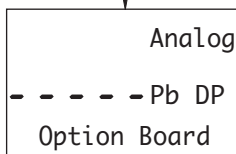
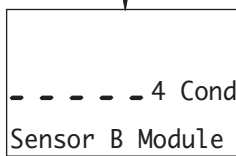
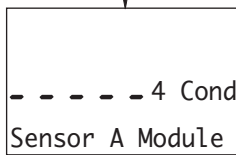
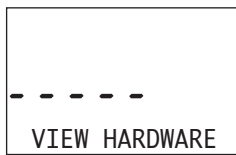

Sensor A Module

Shows the type of input board fitted to the analyzer for the Sensor A input.

4 Cond – 4-Electrode Conductivity

Sensor B Module – Dual input analyzers only

Shows the type of input board fitted to the analyzer for the Sensor B input.

Option Board

Note. Displayed only if the option board is fitted.

Displays the optional features enabled in the **Factory Settings** page – see Section 7.3.

VIEW HARDWARE

VIEW SOFTWARE See Section 3.4.

SENSOR CAL. See Section 4.1.

3.4 View Software

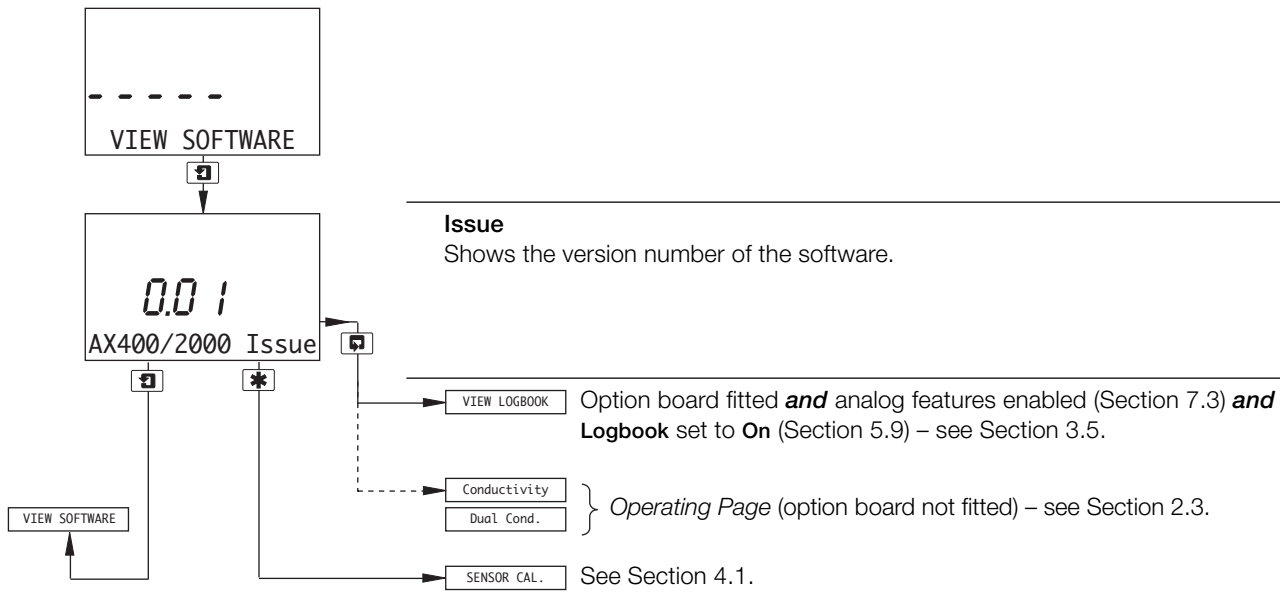

3.5 View Logbook

Note. The View Logbook function is available only if the option board is fitted **and** analog features enabled (Section 7.3) **and** Logbook is set to **On** (Section 5.9).

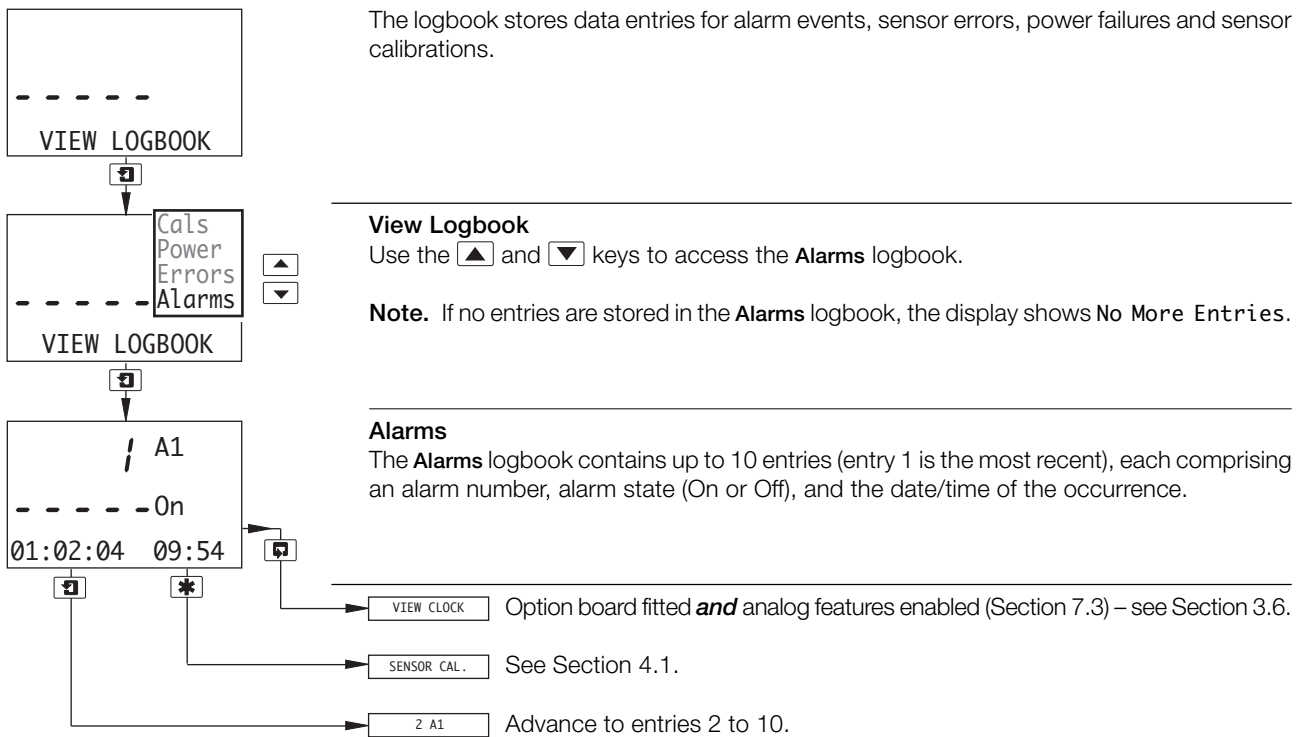

Note. If no more entries are stored, the display shows **No More Entries**.

...3.5 Logbook

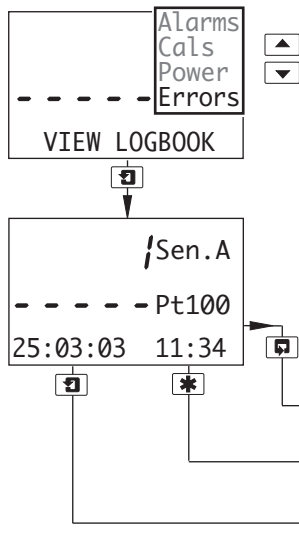

View Logbook

Use the ▲ and ▼ keys to access the **Errors** logbook.

Note. If no entries are stored in the **Errors** logbook, the display shows **No More Entries**.

Errors

The **Errors** logbook contains up to 5 entries (entry 1 is the most recent), each comprising the sensor letter, error number and the date/time of the occurrence.

- VIEW CLOCK Option board fitted **and** analog features enabled (Section 7.3) – see Section 3.6.
- SENSOR CAL. See Section 4.1.
- 2 Sen.A Advance to entries 2 to 5.

Note. If no more entries are stored, the display shows **No More Entries**.

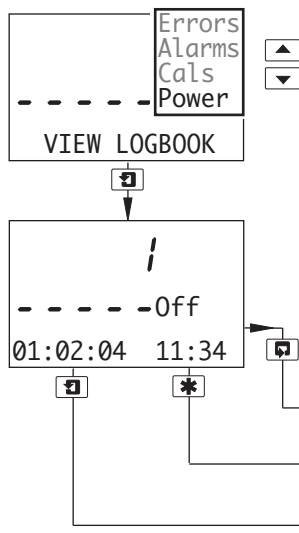

View Logbook

Use the ▲ and ▼ keys to access the **Power** logbook.

Note. If no entries are stored in the **Power** logbook, the display shows **No More Entries**.

Power

The **Power** logbook contains up to 2 entries (entry 1 is the most recent), each comprising the power state (On or Off) and the date/time of the occurrence.

- VIEW CLOCK Option board fitted **and** analog features enabled (Section 7.3) – see Section 3.6.
- SENSOR CAL. See Section 4.1.
- 2 Advance to entry 2.

Note. If no more entries are stored, the display shows **No More Entries**.

...3 OPERATOR VIEWS

...3.5 Logbook

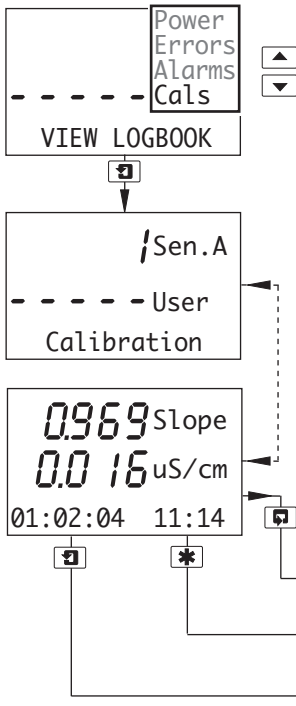

View Logbook

Use the and keys to access the **Cals** logbook.

Note. If no entries are stored in the **Cals** logbook, the display shows **No More Entries**.

Calibration

The **Cals** logbook contains up to 5 entries (entry 1 is the most recent), each comprising 2 frames. Frame 1 contains the entry number and sensor letter and shows **User** to indicate a user performed calibration.

Frame 2 contains either the the sensor % slope and sensor offset values (for a conductivity calibration), or the temperature % slope and temperature offset values (for a temperature calibration), together with the date/time of the calibration.

Note. If no more entries are stored, the display shows **No More Entries**.

Option board fitted **and** analog features enabled (Section 7.3) – see Section 3.6.

See Section 4.1.

Advance to entries 2 to 5.

Note. If no more entries are stored, the display shows **No More Entries**.

3.6 View Clock

Note. The View Clock function is available only if the option board is fitted **and** analog features enabled – see Section 7.3.

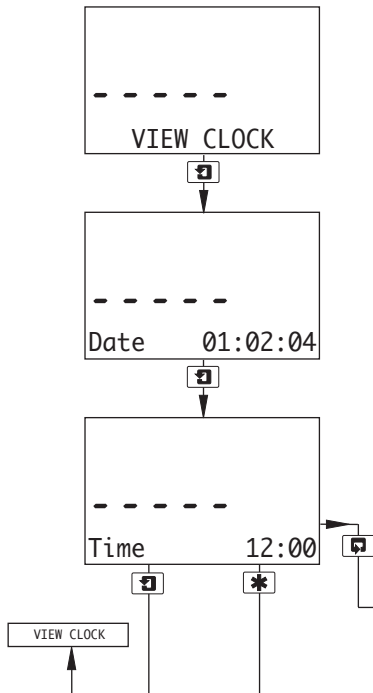

Date

Shows the current date.

Time

Shows the current time.

} *Operating Page* – see Section 2.3.

See Section 4.1.

4 SETUP

4.1 Sensor Calibration

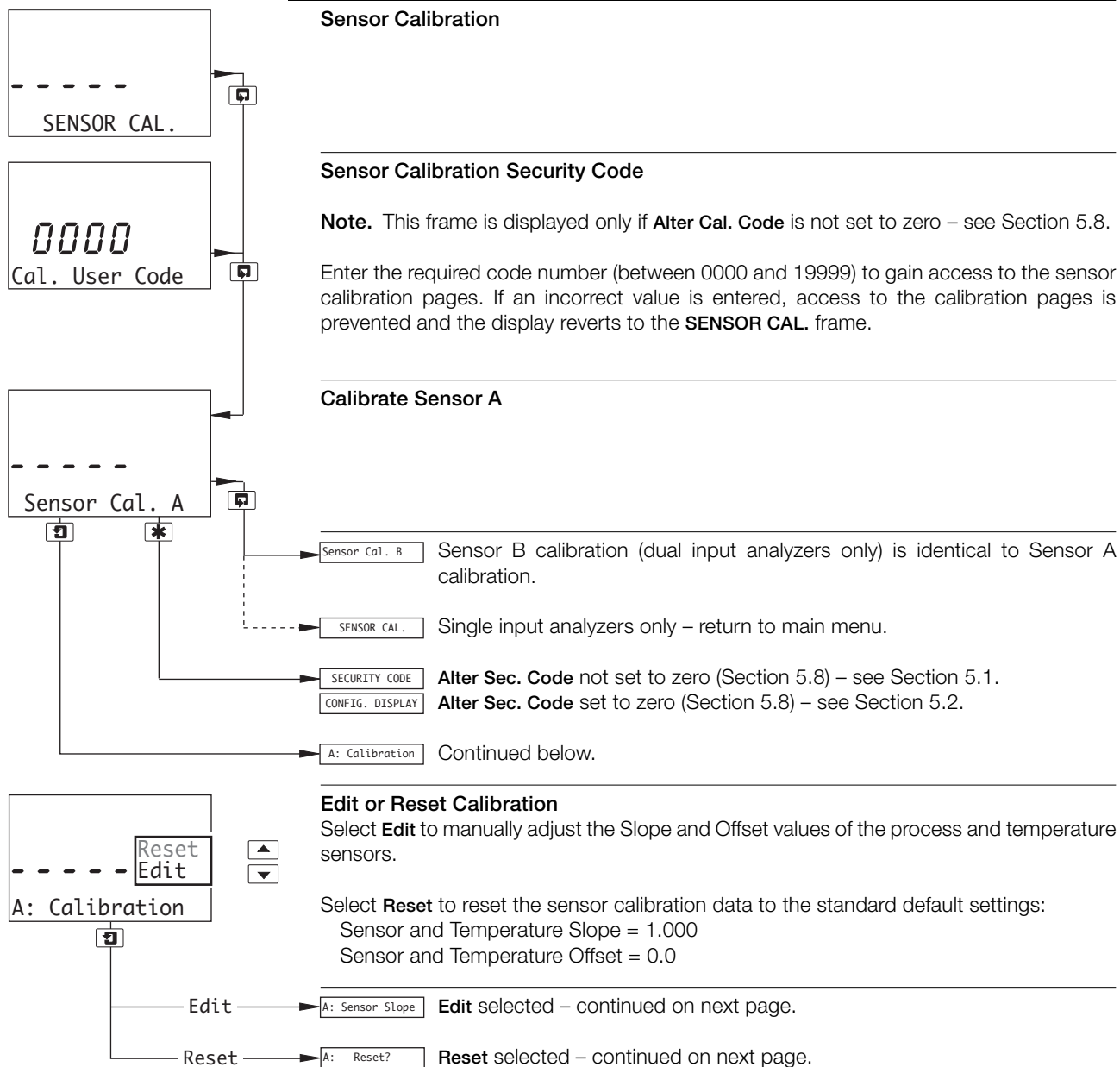

...4 SETUP

...4.1 Sensor Calibration

A: Calibration
set to Edit

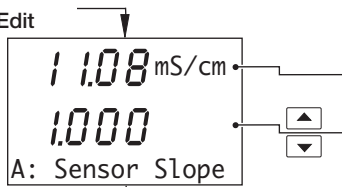

Sensor Slope

Measured conductivity value.

Sensor slope value.

Use the ▲ and ▼ keys to adjust the sensor slope value within the range 0.200 to 5.000 until the measured conductivity value is correct.

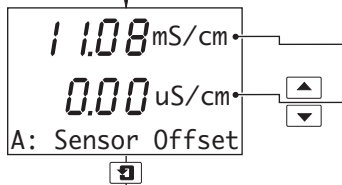

Sensor Offset

Measured conductivity value.

Sensor offset value.

Use the ▲ and ▼ keys to adjust the sensor offset value within the range -20.00 to 20.00 until the measured conductivity value is correct.

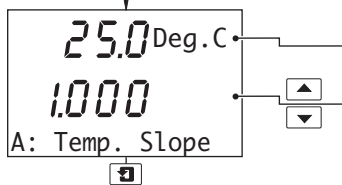

Temperature Slope

Measured temperature value.

Temperature slope value.

Use the ▲ and ▼ keys to adjust the temperature slope value within the range 0.200 to 1.500 until the measured temperature value is correct.

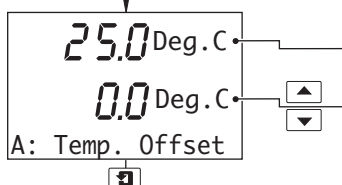

Temperature Offset

Measured temperature value.

Temperature offset value.

Use the ▲ and ▼ keys to adjust the temperature offset value within the range -40.0 to 40.0°C (-40.0 to 104.0°F) until the measured temperature value is correct.

[Sensor Cal. B](#) Sensor B calibration (dual input analyzers only) is identical to Sensor A calibration.

[Sensor Cal. A](#) Single input analyzers only – return to top of page.

A: Calibration
set to Reset

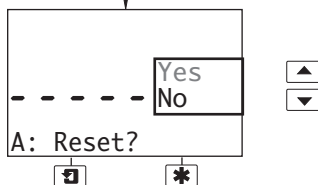

Reset Calibration

Select **Yes** and press **1** to reset the calibration data.

Select **No** and press **1** to abort.

[Sensor Cal. A](#) Return to top of page.

5 PROGRAMMING

5.1 Security Code



Note. This frame is displayed only if **Alter Sec. Code** is not set to zero – see Section 5.8.

Enter the required code number (between 0000 and 19999), to gain access to the configuration pages. If an incorrect value is entered, access to the configuration pages is prevented and the display reverts to the *Operating Page* – see Section 2.3.

→ CONFIG. DISPLAY See Section 5.2.

5.2 Configure Display

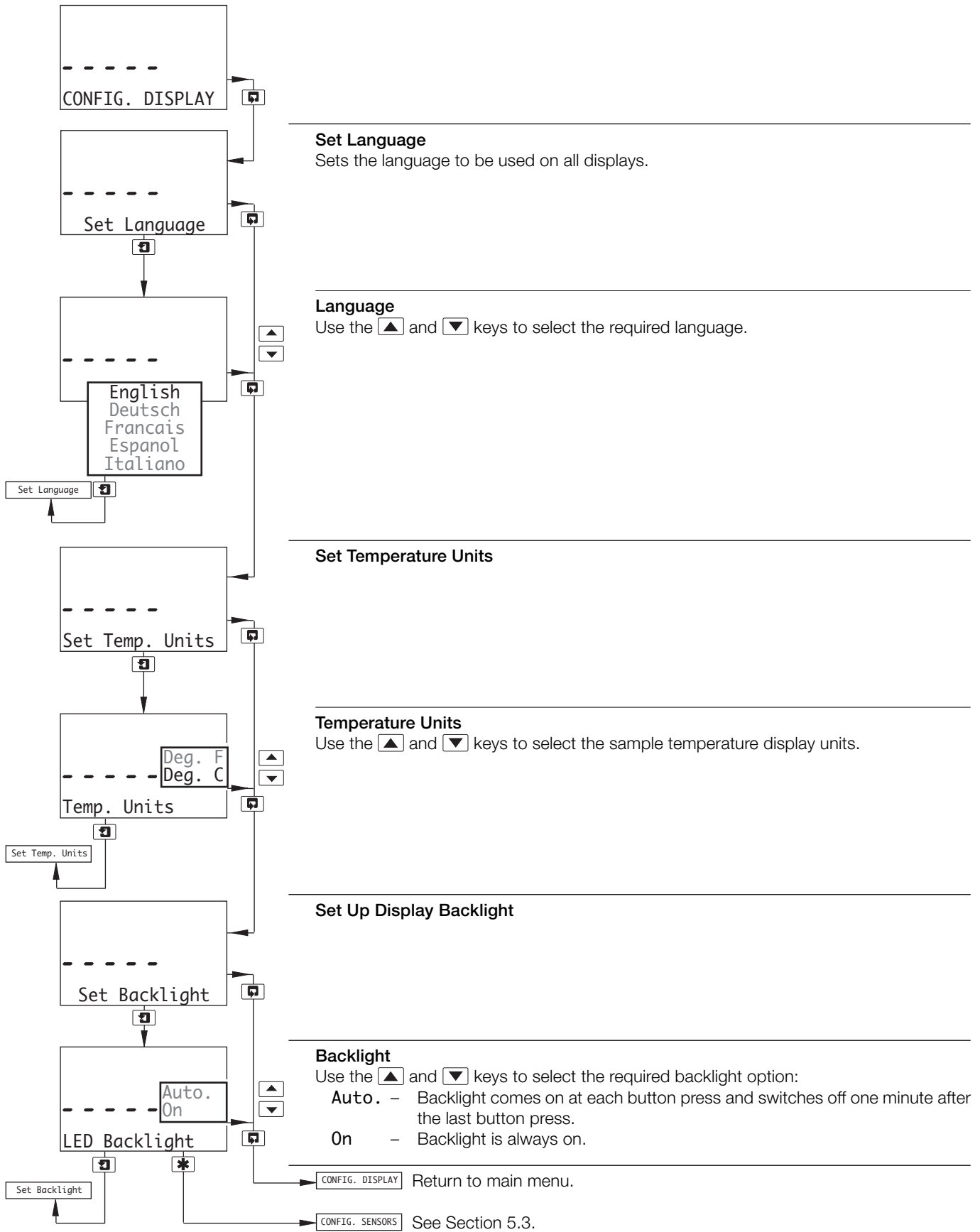

5.3 Configure Sensors

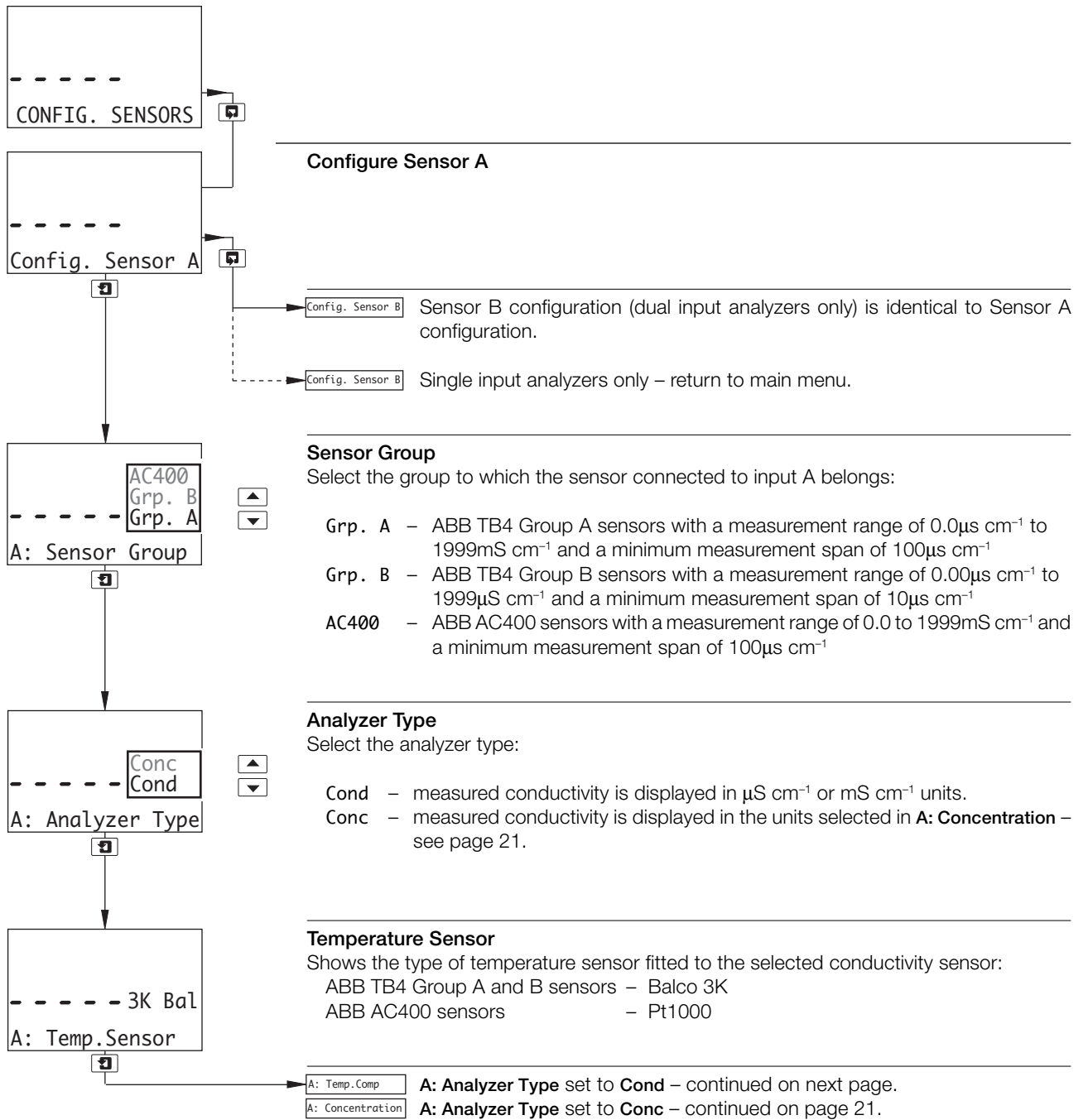

...5.3 Configure Sensors

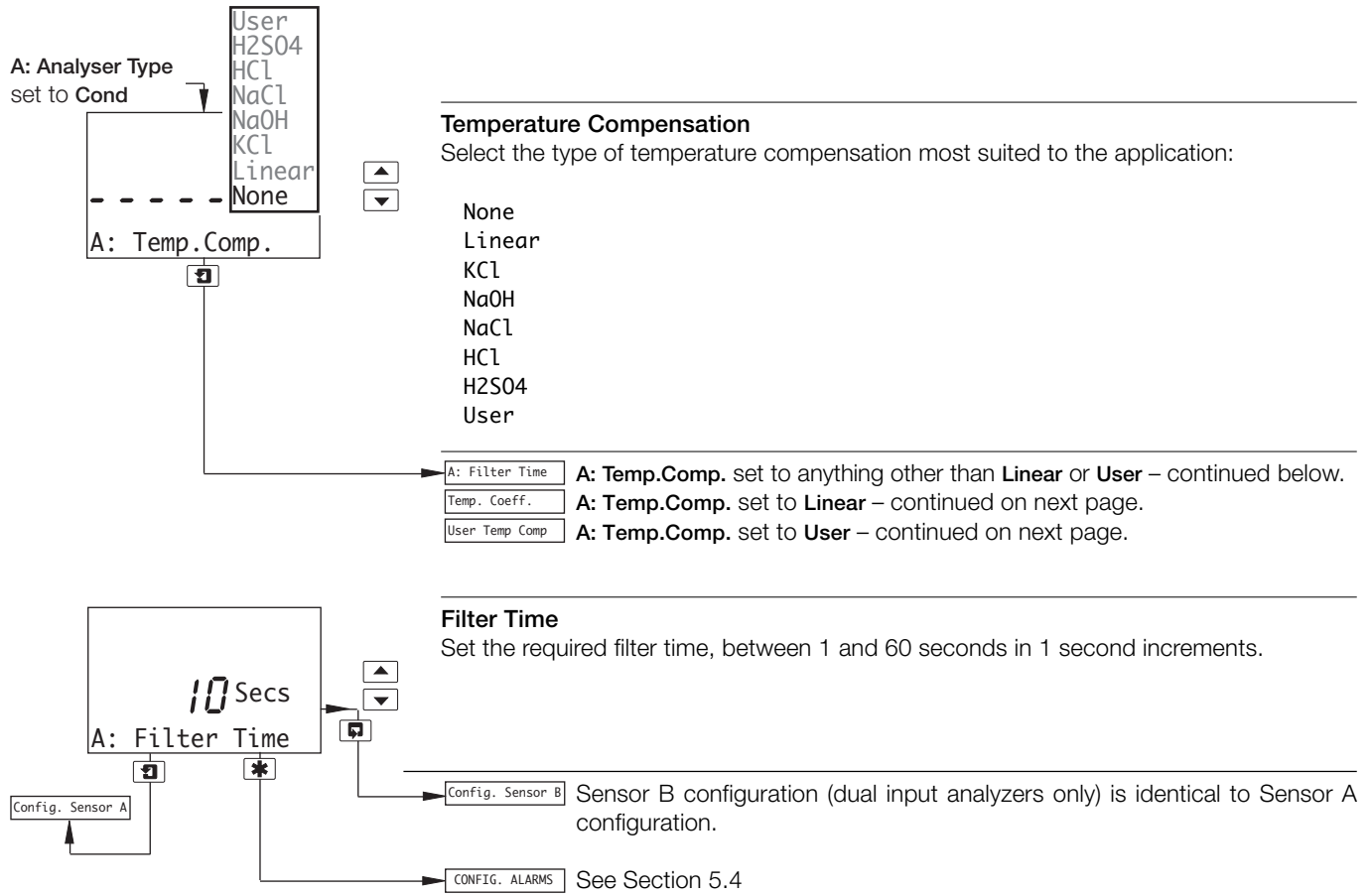

...5.3 Configure Sensors

A: Temp.Comp.
set to Linear

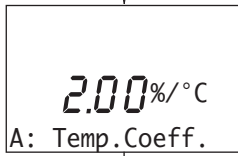

Temperature Coefficient

Enter the temperature coefficient ($\alpha \times 100$) of the solution (0.01 to 5.0%/°C). If unknown, the temperature coefficient (α) of the solution must be calculated – see Appendix A1.1.

If the value has not yet been calculated, set it to 2%/°C provisionally.



Filter Time

Set the required filter time, between 1 and 60 seconds in 1 second increments.

Config. Sensor A

Config. Sensor B

Sensor B configuration (dual input analyzers only) is identical to Sensor A configuration.

CONFIG. ALARMS

See Section 5.4.

A: Temp.Comp.
set to User

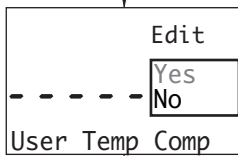

Edit User Defined Temperature Compensation

Select **Yes** to manually define a 6-point temperature compensation curve, otherwise select **No**.

Yes

A: Enter Point 1

Continued on next page.

No



Filter Time

Set the required filter time, between 1 and 60 seconds in 1 second increments.

Config. Sensor A

Config. Sensor B

Sensor B configuration (dual input analyzers only) is identical to Sensor A configuration.

CONFIG. ALARMS

See Section 5.4.

...5.3 Configure Sensors

User Temp Comp
set to Yes

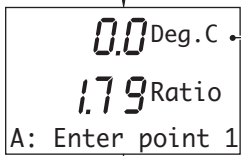

Temperature Value – Point 1

Deg. C (or **Deg. F**) and **Adjust** are shown alternately on the upper display line. Use the ▲ and ▼ keys to adjust the displayed reading to the required temperature value for point 1 on the curve.

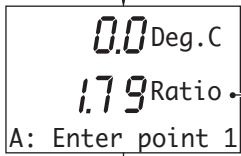

Ratio Value – Point 1

Ratio and **Adjust** are shown alternately on the center display line. Use the ▲ and ▼ keys to adjust the displayed reading to the required ratio value for point 1 on the curve.

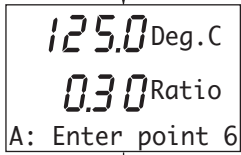

Temperature and Ratio Values – Points 2 to 6

Enter the temperature and ratio values for the remaining points in the user-defined temperature compensation curve.



Filter Time

Set the required filter time, between 1 and 60 seconds in 1 second increments.

Config. Sensor A

Config. Sensor B

Sensor B configuration (dual input analyzers only) is identical to Sensor A configuration.

CONFIG. ALARMS

See Section 5.4.

...5.3 Configure Sensors

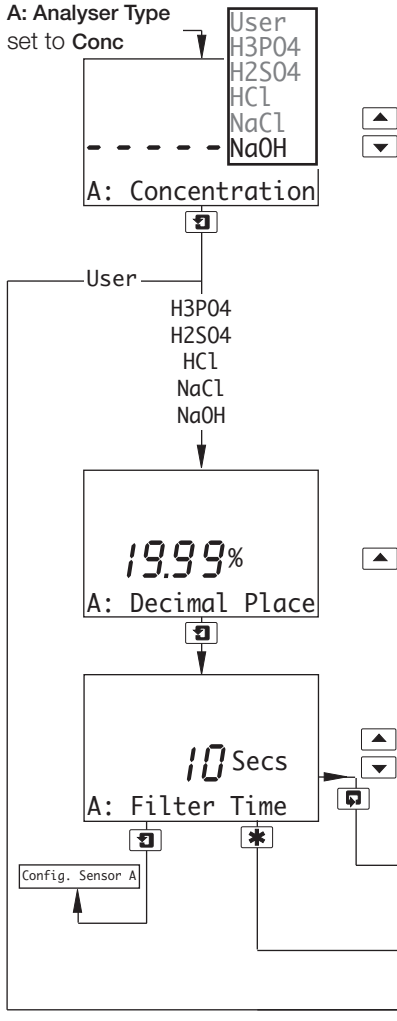

Concentration

Select the required concentration measurement:

- NaOH – minimum 0%; maximum 15%
- NaCl – minimum 0%; maximum 20%
- HCl – minimum 0%; maximum 18%
- H2S04 – minimum 0%; maximum 20%
- H3P04 – minimum 0%; maximum 40%
- User – minimum 0%; maximum 100%

Note. If **A: Sensor Group** is set to **AC400** (see page 17), reduce the maximum concentration values to 6% for acids and 8% for alkalis. Exposure to higher concentrations will reduce both the accuracy and the life of the AC400 sensors.

Decimal Place

Set the position of the decimal point.

Filter Time

Set the required filter time, between 1 and 60 seconds in 1 second increments.

Config. Sensor B Sensor B configuration (dual input analyzers only) is identical to Sensor A configuration.

CONFIG. ALARMS See Section 5.4.

User Units Continued on next page.

...5.3 Configure Sensors

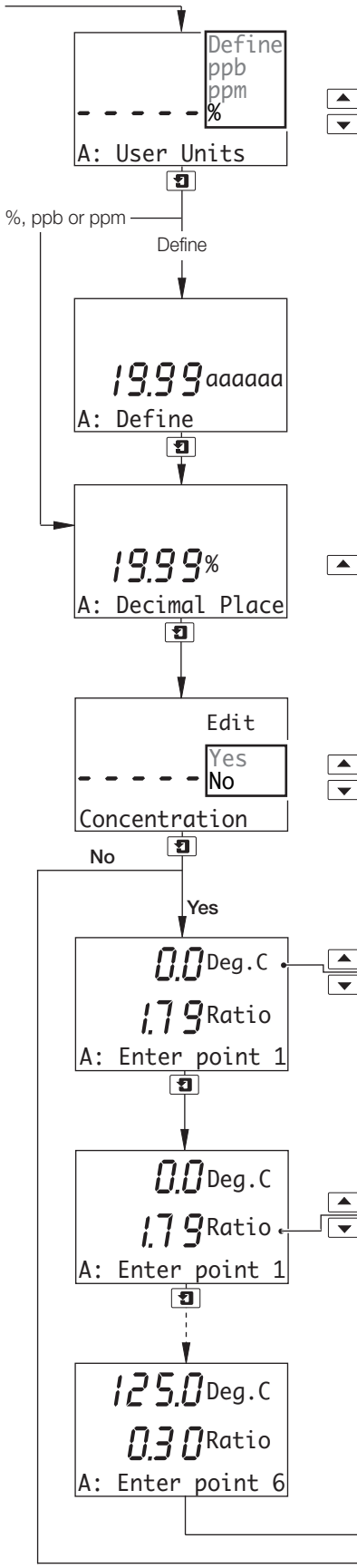

User Units

Select the required concentration units:
 % - concentration as a percentage
 ppm - parts-per-million
 ppb - parts-per-billion
 Define - User defined units

Define User Units

Use the and keys to select a character at the cursor position. Use the key to enter the character and move the cursor.

Press the key when complete to advance to the next frame.

Decimal Place

Set the position of the decimal point.

Edit Concentration

Select **Yes** to manually define a 6-point concentration curve, otherwise select **No**.

Temperature Value – Point 1

Deg. C (or **Deg. F**) and **Adjust** are shown alternately on the upper display line. Use the and keys to adjust the displayed reading to the required temperature value for point 1 on the curve.

Ratio Value – Point 1

Ratio and **Adjust** are shown alternately on the center display line. Use the and keys to adjust the displayed reading to the required ratio value for point 1 on the curve.

Temperature and Ratio Values – Points 2 to 6

Enter the temperature and ratio values for the remaining points in the user-defined temperature compensation curve.

Continued on next page.
 Continued on next page.

...5.3 Configure Sensors

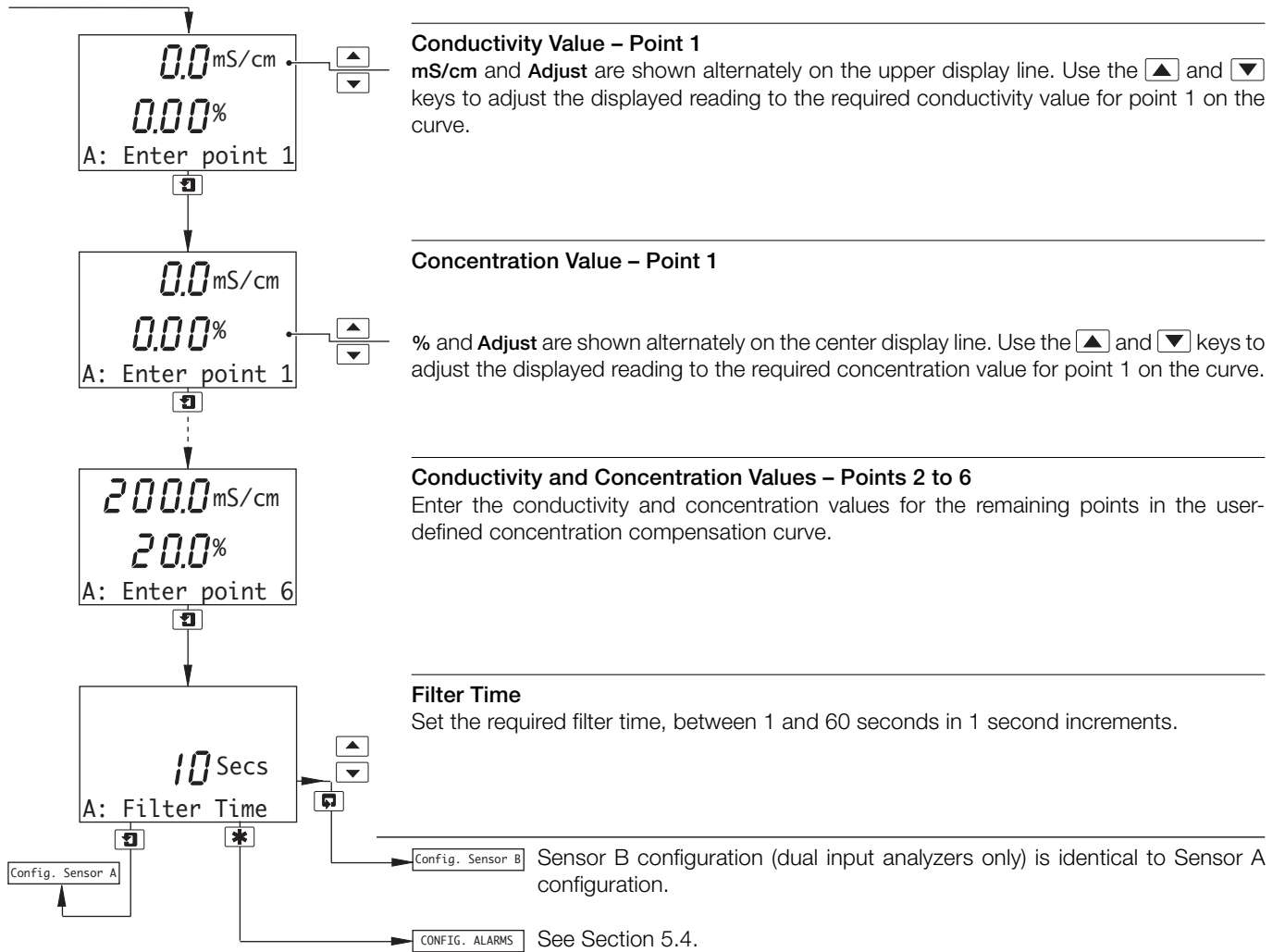

5.4 Configure Alarms

5.4.1 Configure Standard Alarms

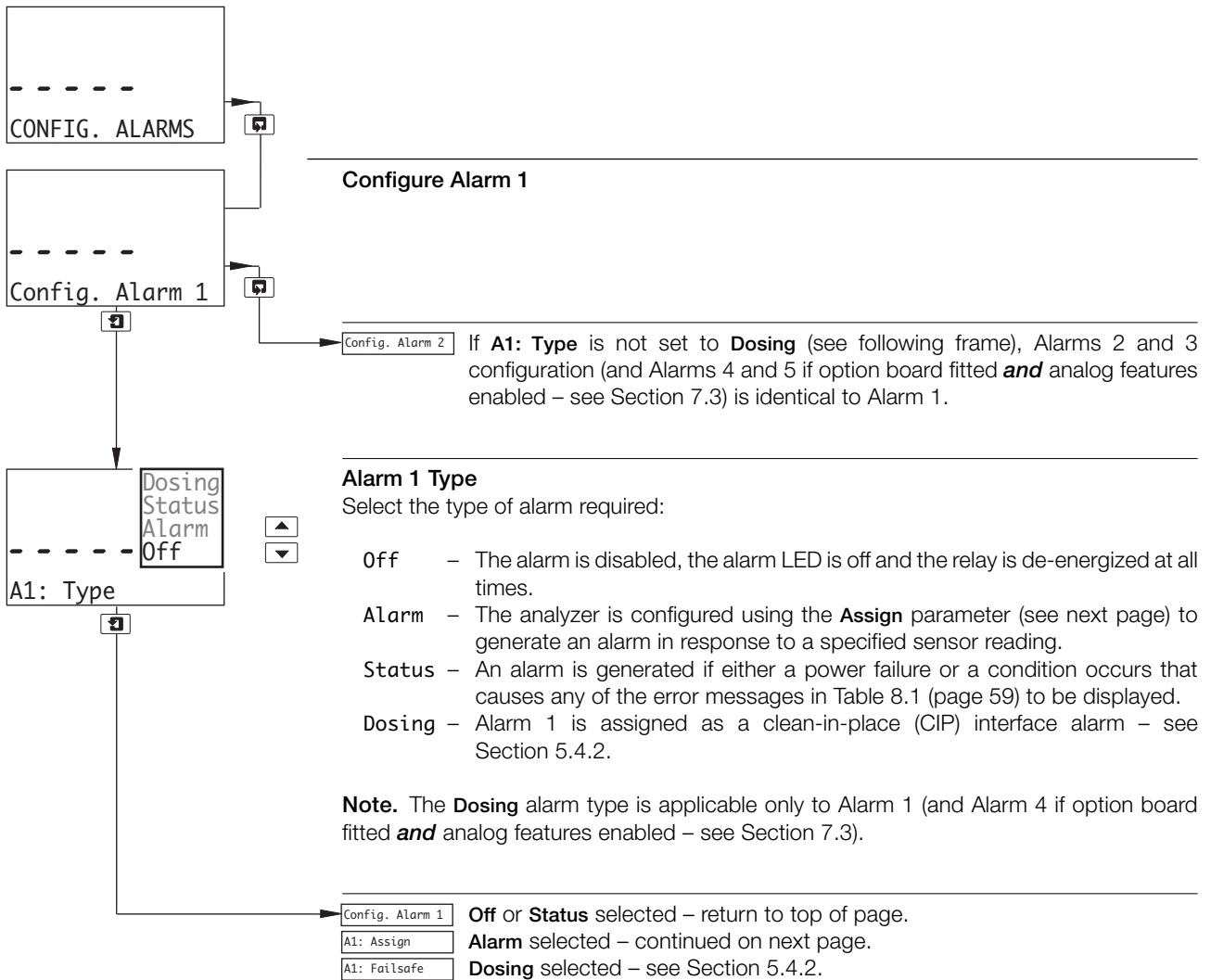

...5.4 Configure Alarms

...5.4.1 Configure Standard Alarms

A1: Type

set to Alarm

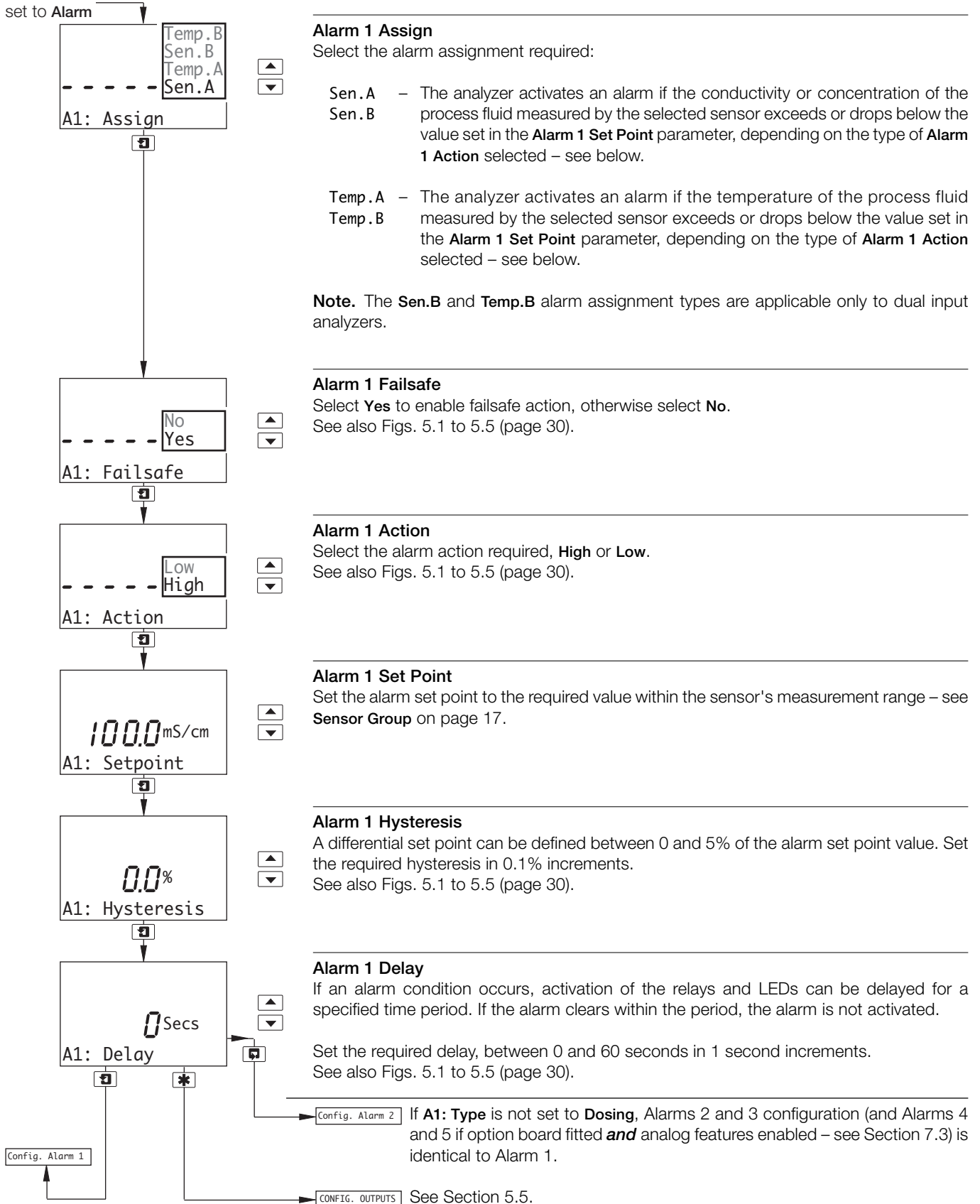

Alarm 1 Assign

Select the alarm assignment required:

Sen.A – The analyzer activates an alarm if the conductivity or concentration of the process fluid measured by the selected sensor exceeds or drops below the value set in the **Alarm 1 Set Point** parameter, depending on the type of **Alarm 1 Action** selected – see below.
Sen.B

Temp.A – The analyzer activates an alarm if the temperature of the process fluid measured by the selected sensor exceeds or drops below the value set in the **Alarm 1 Set Point** parameter, depending on the type of **Alarm 1 Action** selected – see below.
Temp.B

Note. The **Sen.B** and **Temp.B** alarm assignment types are applicable only to dual input analyzers.

Alarm 1 Failsafe

Select **Yes** to enable failsafe action, otherwise select **No**.

See also Figs. 5.1 to 5.5 (page 30).

Alarm 1 Action

Select the alarm action required, **High** or **Low**.

See also Figs. 5.1 to 5.5 (page 30).

Alarm 1 Set Point

Set the alarm set point to the required value within the sensor's measurement range – see **Sensor Group** on page 17.

Alarm 1 Hysteresis

A differential set point can be defined between 0 and 5% of the alarm set point value. Set the required hysteresis in 0.1% increments.

See also Figs. 5.1 to 5.5 (page 30).

Alarm 1 Delay

If an alarm condition occurs, activation of the relays and LEDs can be delayed for a specified time period. If the alarm clears within the period, the alarm is not activated.

Set the required delay, between 0 and 60 seconds in 1 second increments.

See also Figs. 5.1 to 5.5 (page 30).

If **A1: Type** is not set to **Dosing**, Alarms 2 and 3 configuration (and Alarms 4 and 5 if option board fitted **and** analog features enabled – see Section 7.3) is identical to Alarm 1.

See Section 5.5.

...5.4 Configure Alarms

5.4.2 Configure CIP Interface Alarm

Notes.

- This section is applicable only if **A1: Type** is set to **Dosing** – see Section 5.4.1.
- Alarm 4 (dual input analyzers only with option board fitted **and** analog features enabled – see Section 7.3) can be configured as a CIP Interface alarm for Sensor B, therefore this Section applies also to Alarm 4.
- When Alarm 1 (and/or Alarm 4) is assigned as a CIP Interface alarm, the error messages shown in Table 5.1 on page 29 are displayed in response to the events described.

A1: Type

set to Dosing

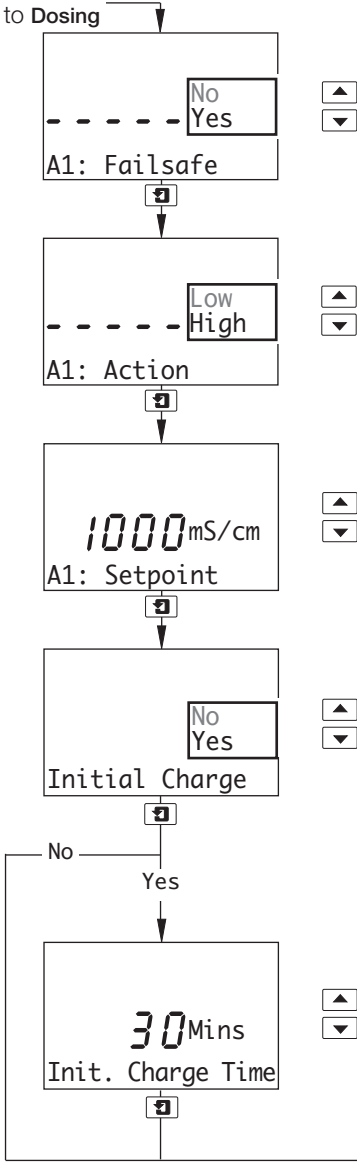

Alarm 1 Failsafe

Select **Yes** to enable failsafe action, otherwise select **No**.
See also Figs. 5.1 to 5.5 (page 30).

Alarm 1 Action

Select the alarm action required, **High** or **Low**.
See also Figs. 5.1 to 5.5 (page 30).

Alarm 1 Set Point

Set the alarm set point to the required value within the sensor's measurement range – see **Sensor Group** on page 17.

Initial Charge

Select **Yes** to enable an initial charge sequence. The initial charge sequence commences when **A: Initial Charge** is set manually to **Yes** in the *Operating Page* (Section 2.3.1) and continues for the initial charge time period set below.

Initial Charge Time

Set the initial charge period, between 1 and 30 minutes in 1 minute increments.

Dosing Continued on next page.

...5.4 Configure Alarms

...5.4.2 Configure CIP Interface Alarm

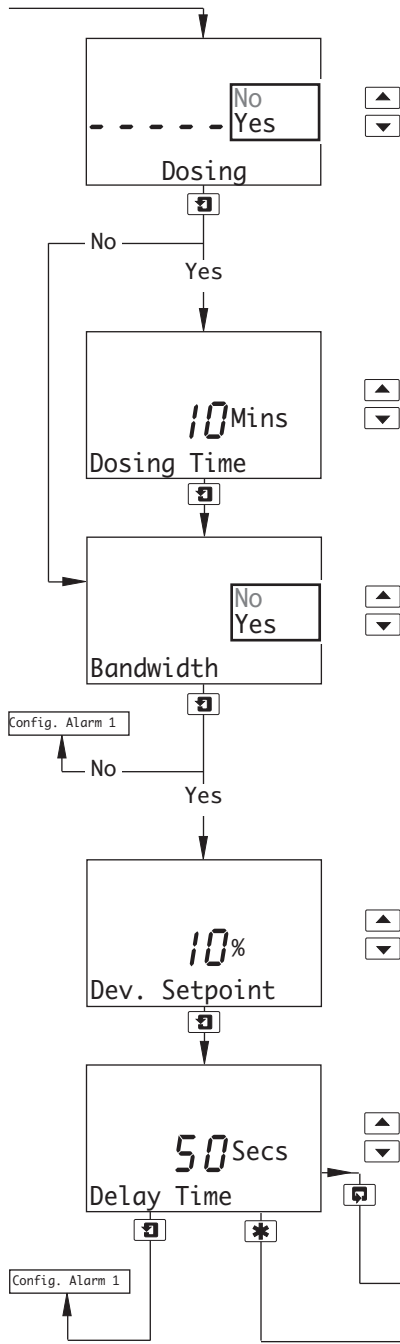

Dosing

Select **Yes** to enable dosing action, otherwise select **No**.

Dosing is inhibited until the initial charge sequence is complete **and** the measured conductivity exceeds the Alarm 1 set point value.

Dosing is enabled when the measured conductivity falls below the Alarm 1 set point value and continues for the dosing time period set below.

Dosing Time

Set the dosing period, between 1 and 10 minutes in 1 minute increments.

Bandwidth Alarm

Select **Yes** to enable the bandwidth alarm, otherwise select **No**.

The bandwidth alarm is activated if the measured conductivity either exceeds the Alarm 1 set point value plus the deviation set point value (see below), or falls below the Alarm 1 set point value minus the deviation set point value.

Example: If **A1: Setpoint** is set to **1000mS/cm** and **Dev. Setpoint** is set to **25%**, the bandwidth alarm is activated if the process variable exceeds 1250mS/cm.

Deviation Set Point

Set the deviation set point, between 1 and 100% of the Alarm 1 set point value in 1% increments.

Delay Time

If a bandwidth alarm condition occurs, activation of the relays and LEDs can be delayed for the specified time period. If the alarm clears within the period, the alarm is not activated.

Set the required delay, between 0 and 60 seconds in 1 second increments.

Config. Alarm 2 Continued on next page.

CONFIG. OUTPUTS See Section 5.5.

...5.4 Configure Alarms

5.4.3 Configure CIP Status Alarm

Notes.

- This section is applicable only if **A1: Type** is set to **Dosing** – see Section 5.4.1.
- Alarm 5 (dual input analyzers only with option board fitted **and** analog features enabled – see Section 7.3) can be configured as a CIP Status alarm for Sensor B, therefore this section applies also to Alarm 5.
- When Alarm 1 (and/or Alarm 4) is configured as a CIP Interface alarm, the error messages shown in Table 5.1 are displayed in response to the events described.
- If Alarm 2 is configured as a CIP Status alarm, its associated relay is energized/de-energized and its LED lit and extinguished in response to the events described in Table 5.1.

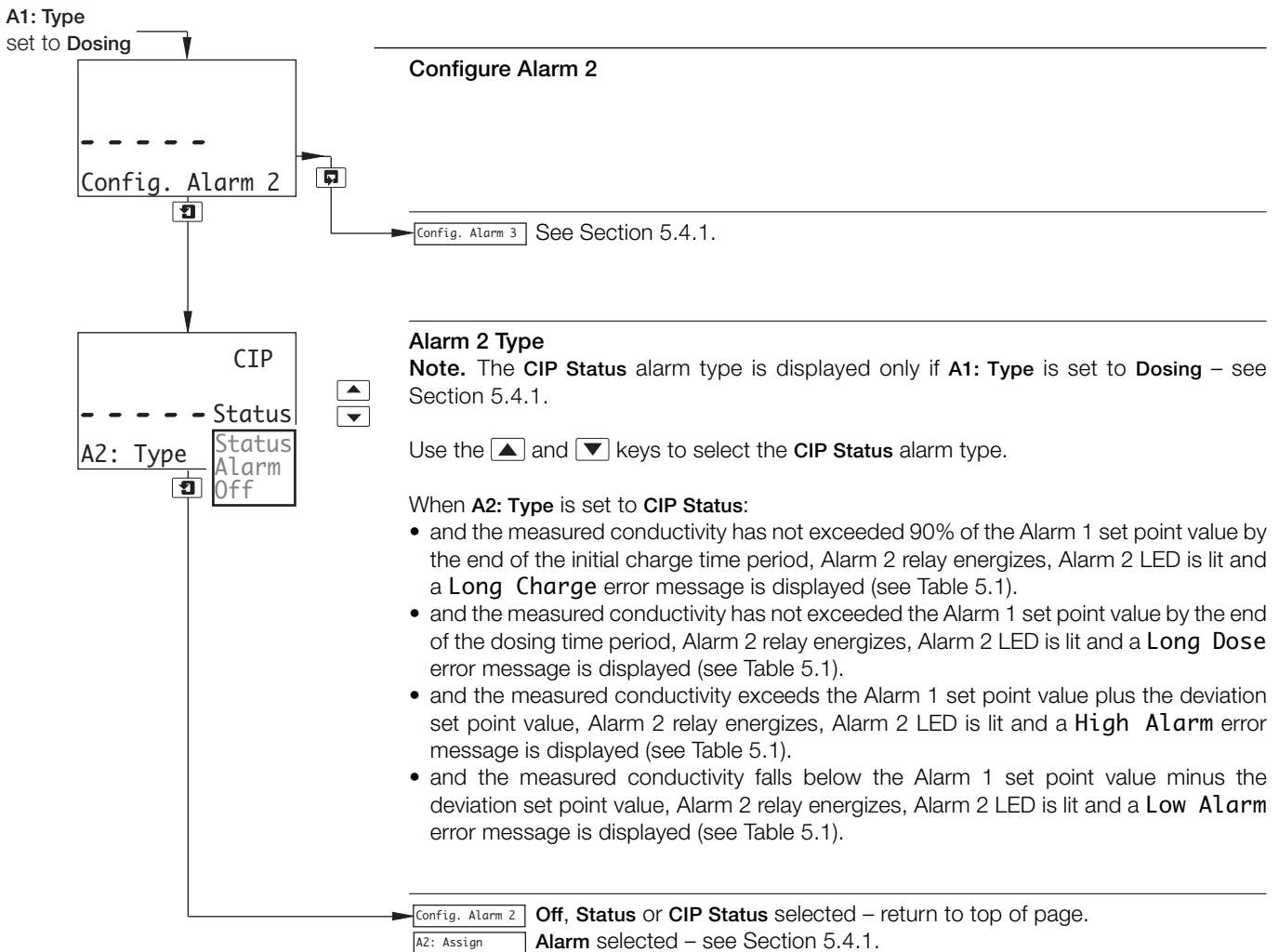

...5.4 Configure Alarms

5.4.3 Configure CIP Status Alarm

Error Message	Active When	Description
Low Alarm	Bandwidth is set to Yes	The measured conductivity is below the Low Alarm set point (Low Alarm set point = Alarm 1 set point value – Bandwidth value)
High Alarm	Bandwidth is set to Yes	The measured conductivity is above the High Alarm set point (High Alarm set point = Alarm 1 set point value + Bandwidth value)
Long Charge	Initial Charge is set to Yes	The initial charge period has expired before the measured conductivity has reached 90% of the Alarm 1 set point value
Long Dosing	Dosing is set to Yes	The dosing period has expired before the measured conductivity has reached the Alarm 1 set point value

Table 5.1 CIP Error Messages

...5 PROGRAMMING

...5.4 Configure Alarms

Note. The following examples illustrate **High Alarm Actions**, i.e. the alarm is activated when the process variable exceeds the defined set point. **Low Alarm Actions** are the same, except the alarm is activated when the process variable drops below the defined set point.

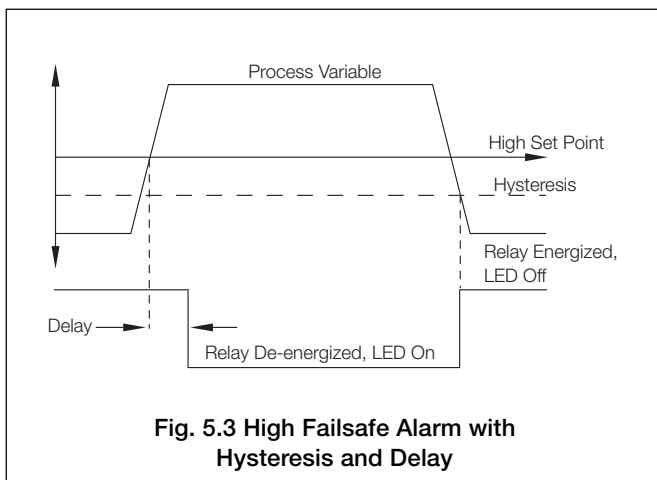
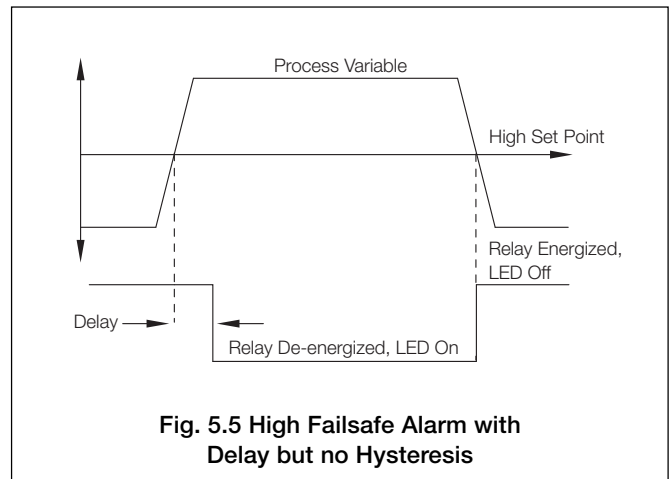
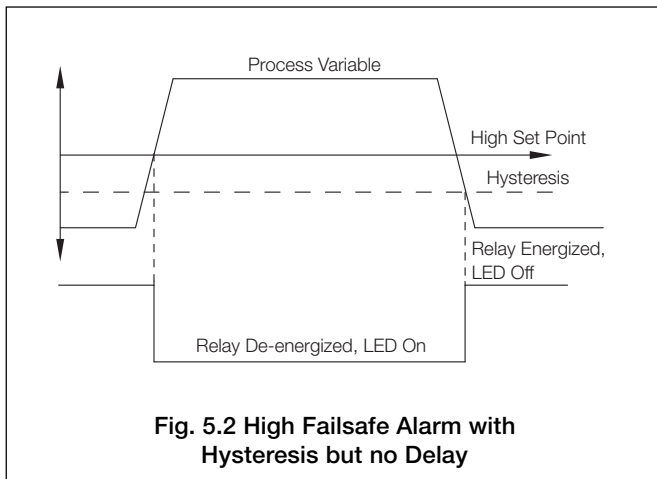
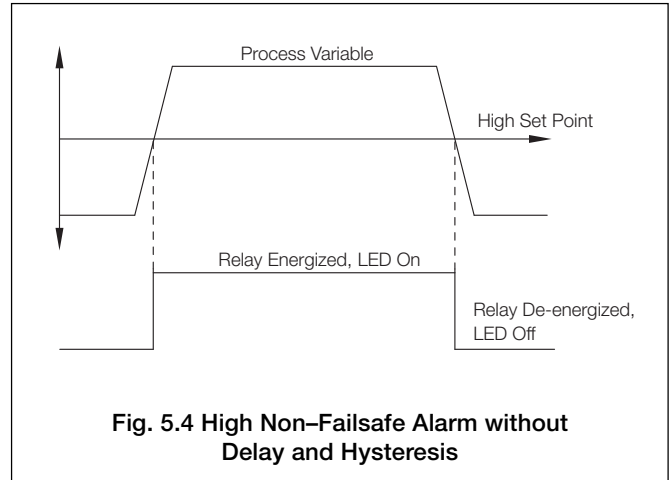
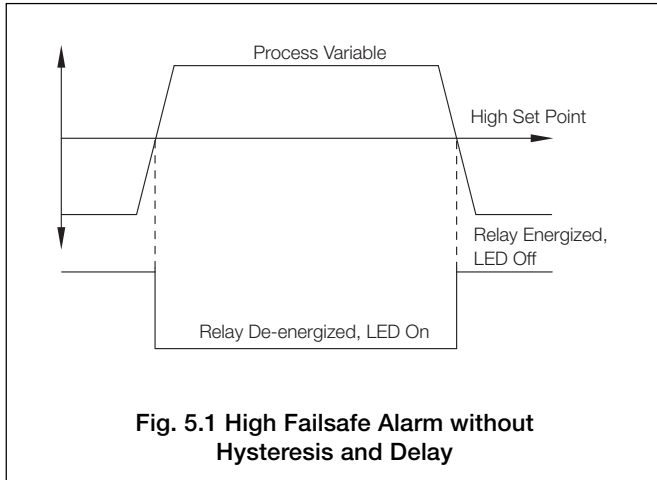

5.5 Configure Outputs

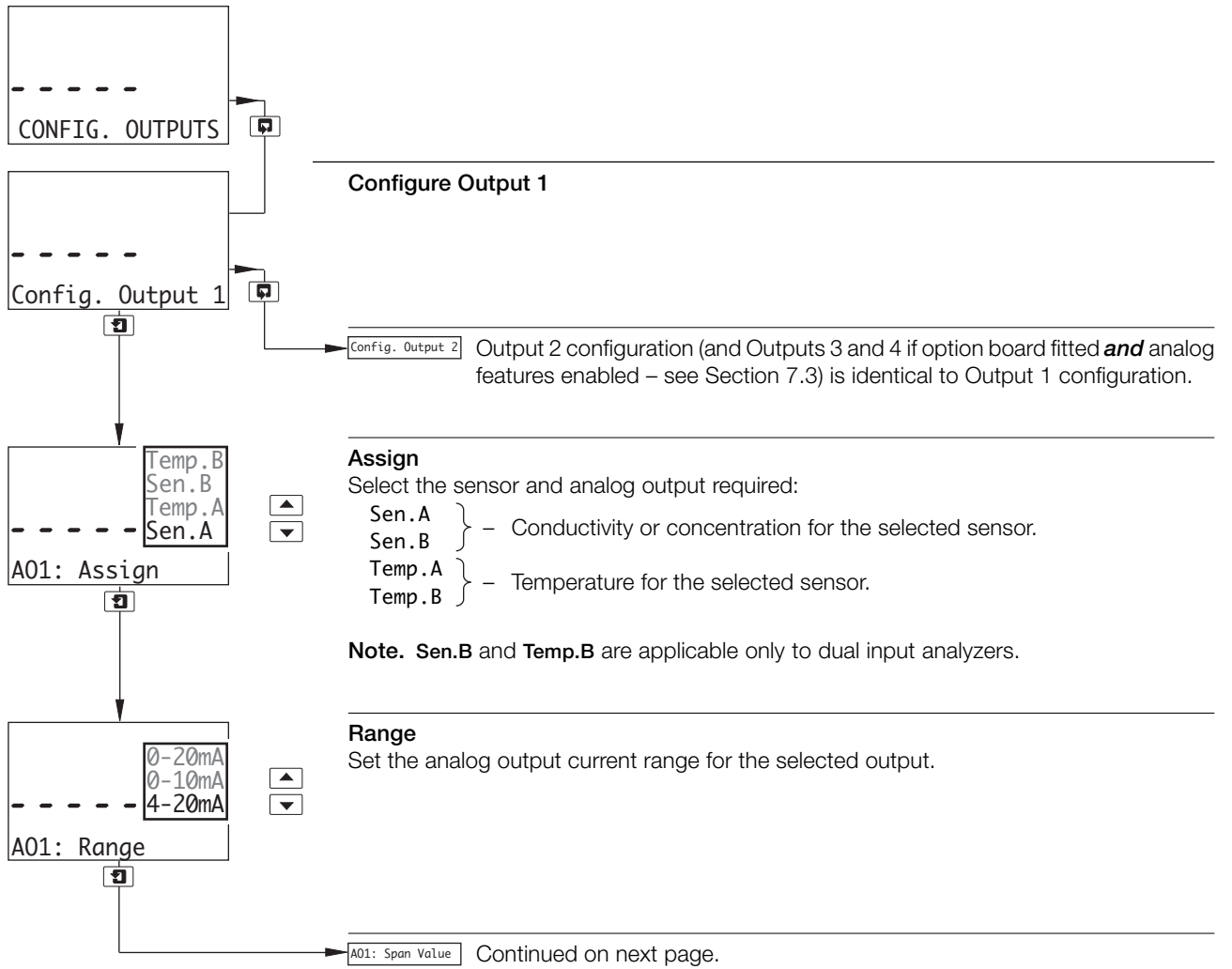

	Span Value		Zero Value		Minimum Difference
	Minimum (%)	Maximum (%)	Minimum (%)	Maximum (%)	
NaOH	0.75	15.00	0.00	14.25	0.75%
NaCl	1.00	20.00	0.00	19.00	1.00%
HCl	0.80	18.00	0.00	17.20	0.80%
H2SO4	1.00	20.00	0.00	19.00	1.00%
H3PO4	2.00	40.00	0.00	38.00	2.00%
User	5.0	100.0	0.0	95.0	5.0%

Table 5.2 Minimum and Maximum Span and Zero Output Settings

...5.5 Configure Outputs

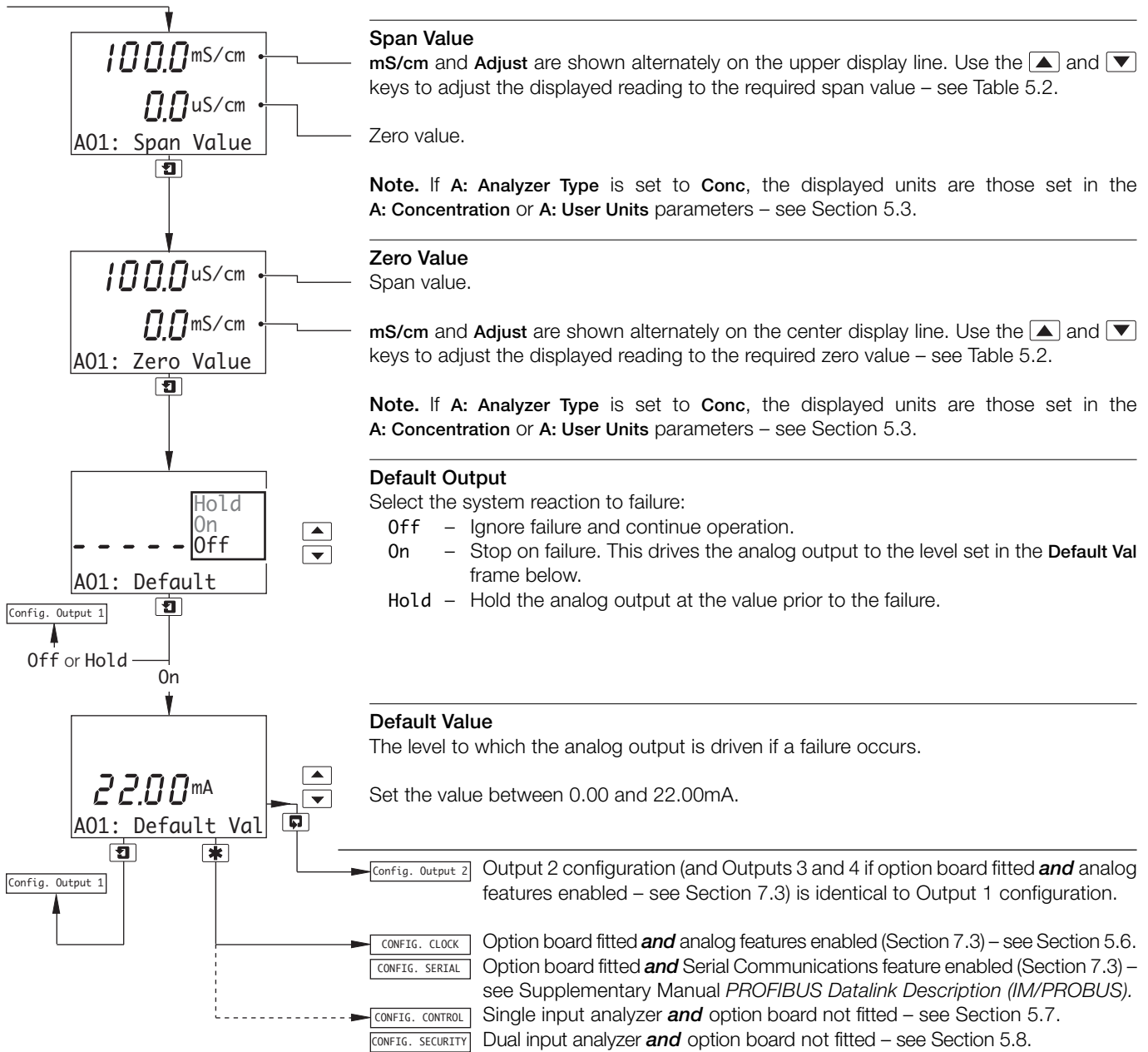

5.6 Configure Clock

Note. The Configure Clock function is available only if the option board is fitted **and** analog features enabled – see Section 7.3.

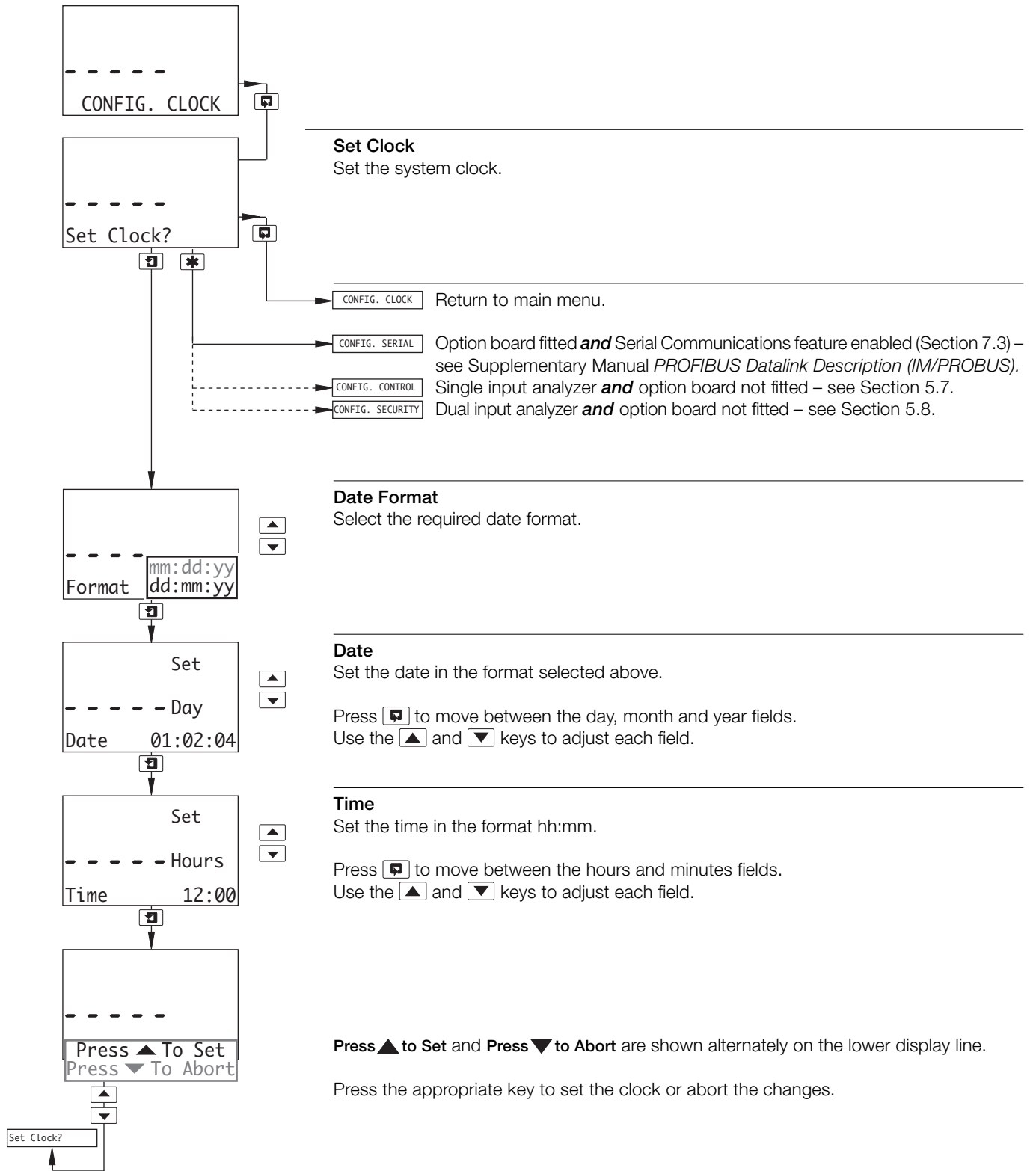

5.7 Configure Control

Notes.

- PID control is applicable only to single input analyzers.
- Before configuring the PID controller, refer to Appendix B for further information.

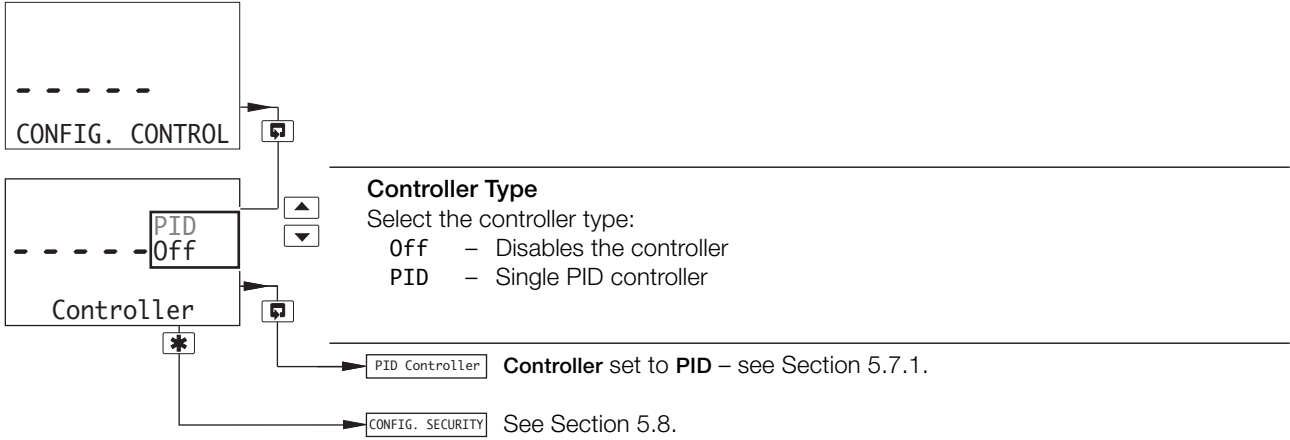

...5.7 Configure Control

5.7.1 Configure Single PID Controller

Controller set to PID

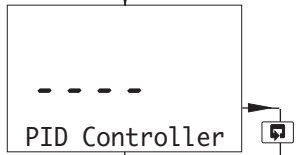

Power Recovery See Section 5.7.2.

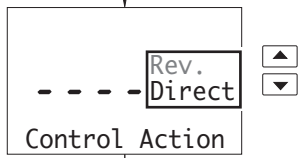

Control Action

Set the required control action:

- Rev. - Reverse acting – see Appendix B, Fig. B2.
- Direct - Direct acting – see Appendix B, Fig. B3.

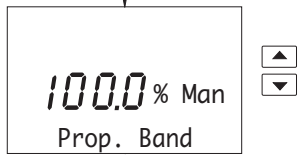

Proportional Band

Set the required proportional band, between 0.0 and 999.9% in 0.1% increments.



Integral Action Time

Set the integral action time, between 1 and 7200 seconds in 1 second increments. Set to OFF to disable integral action time.



Derivative Action Time

Set the derivative action time, between 0.1 and 999.9 seconds in 0.1 second increments. Set to OFF to disable derivative action time.

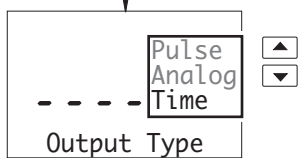

Output Type

Set the required output type:

- Time - Time proportioning (relay 1)
- Analog - Analog output (analog output 1)
- Pulse - Pulse frequency (relay 1)

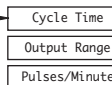

Output Type set to Time – continued on next page.
 Output Type set to Analog – continued on next page.
 Output Type set to Pulse – continued on page 37.

...5.7 Configure Control

...5.7.1 Configure Single PID Controller

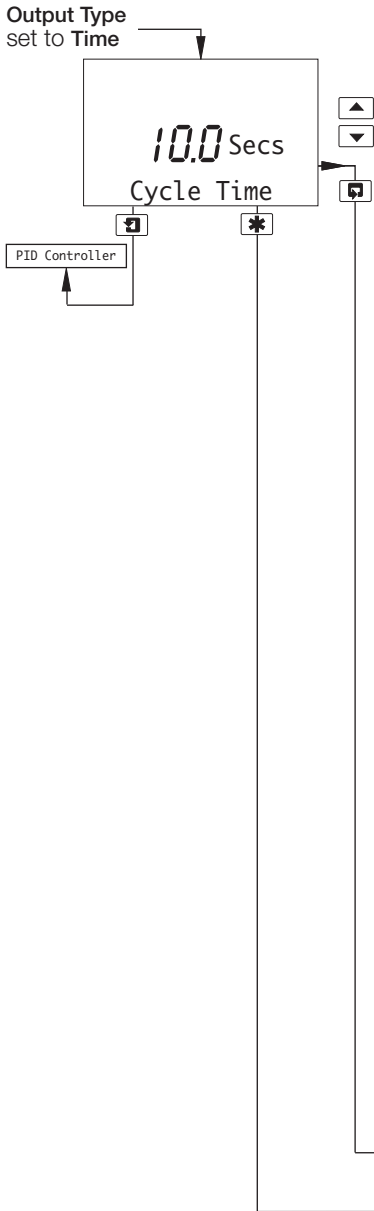

Time Proportioning Output

The Time Proportioning Output is interrelated to the retention time of the vessel and the flow of the chemical reagent and is adjusted experimentally to ensure that the chemical reagent is adequate to control the dosing under maximum loading. It is recommended that the Time Proportioning Output is adjusted in Manual Mode set to 100% valve output before setting up the PID parameters.

The time proportioning output value is calculated using the following equation:

$$\text{on time} = \frac{\text{control output} \times \text{cycle time}}{100}$$

Set the cycle time, between 1.0 and 300.0 seconds in 0.1 second increments – see Appendix B, Fig. B4 Mode C.

Note. Changes to the cycle time do not take effect until the start of a new cycle.

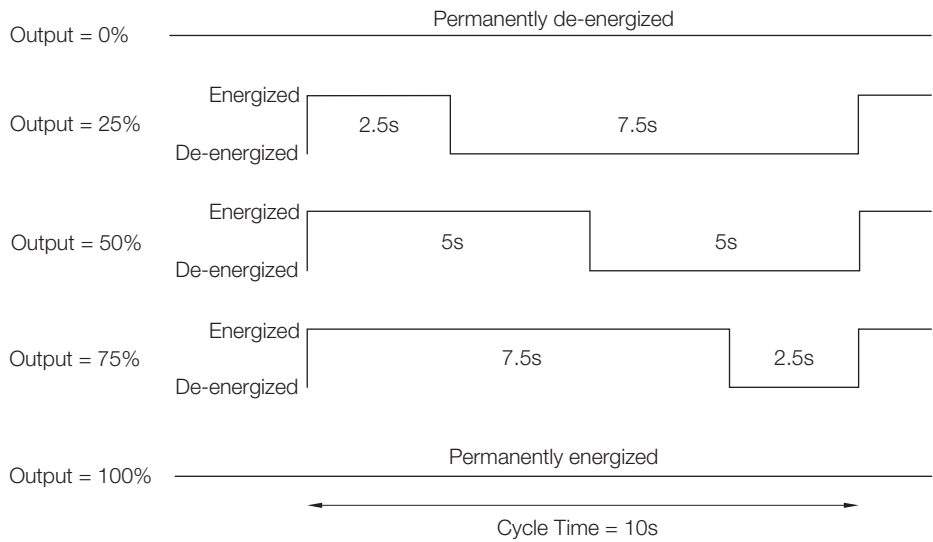

Power Recovery See Section 5.7.2.

CONFIG. SECURITY See Section 5.8.

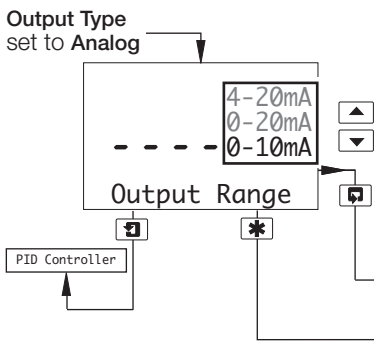

Analog Output

Set the analog current output range.

Power Recovery See Section 5.7.2.

CONFIG. SECURITY See Section 5.8.

...5.7 Configure Control

...5.7.1 Configure Single PID Controller

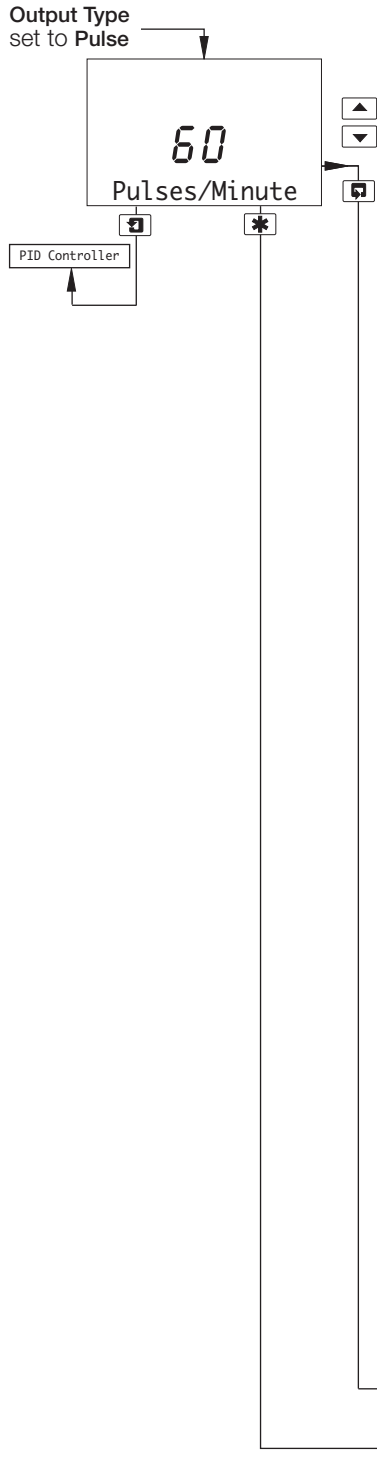

Pulse Frequency Output

The pulse frequency output is the number of relay pulses per minute required for 100% control output. The Pulse Frequency Output is interrelated to the chemical reagent strength and the solution flow rate. The chemical reagent flowrate and pulse frequency is adjusted experimentally to ensure that the chemical reagent is adequate to control the dosing under maximum loading. Adjust the Pulse Frequency Output in Manual Mode and set to 100% valve output before setting up the PID parameters.

For example, if the observed value on the display is 6 and the control point is 5 then the frequency needs to be increased.

The actual number of pulses per minute is calculated using the following equation:

$$\text{Actual pulses per minute} = \frac{\% \text{ control output} \times \text{pulse frequency output}}{100}$$

Set the pulse frequency between 1 and 120 pulses per minute in 1 pulse per minute increments.

Control Output	Pulse Frequency Output/Minute			
	1	10	50	120
0	0	0	0	0
25	0.25	2.5	12.5	30
50	0.50	5.0	25	60
75	0.75	7.5	37.5	90
100	1.00	10.0	50	120

Note. If the pulse frequency of 120 is reached then concentration of the reagent needs to be increased.

Note. Changes to the pulse frequency do not take effect until the start of a new cycle.

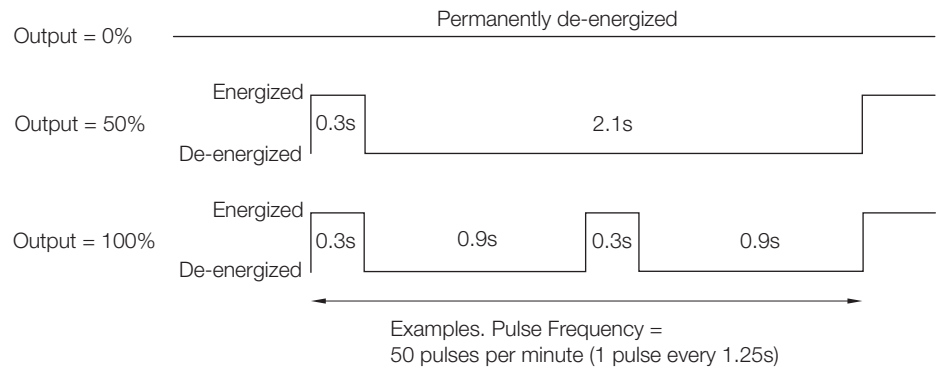

...5.7 Configure Control

5.7.2 Configure Power Failure Recovery Mode

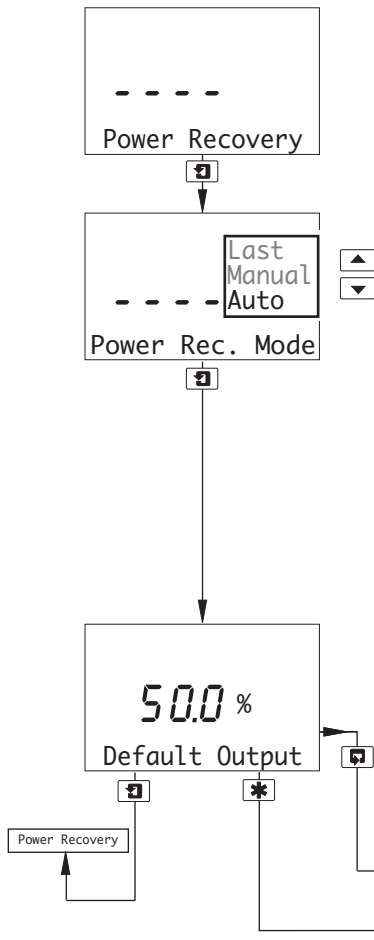

Power Failure Recovery Mode

When power to the analyzer is restored, **Control Mode** (Section 2.3) is set automatically according to the Power Failure Recovery Mode selected in this frame.

Select the required mode:

- Auto** – **Control Mode** is set to **Auto** irrespective of its setting prior to the power failure.
- Manual** – **Control Mode** is set to **Manual** irrespective of its setting prior to the power failure. **Control Output** (Section 2.3) is set to the level set in the **Default Output** frame below.
- Last** – **Control Mode** and **Control Output** are set to the same state as that set prior to the power failure.

Default Output

Set the default output required after Power Failure Recovery, between 0 and 100% in 0.1% increments.

Note. A setting of 0% represents no output.

CONFIG. CONTROL Return to main menu.

CONFIG. SECURITY See Section 5.8.

5.8 Configure Security

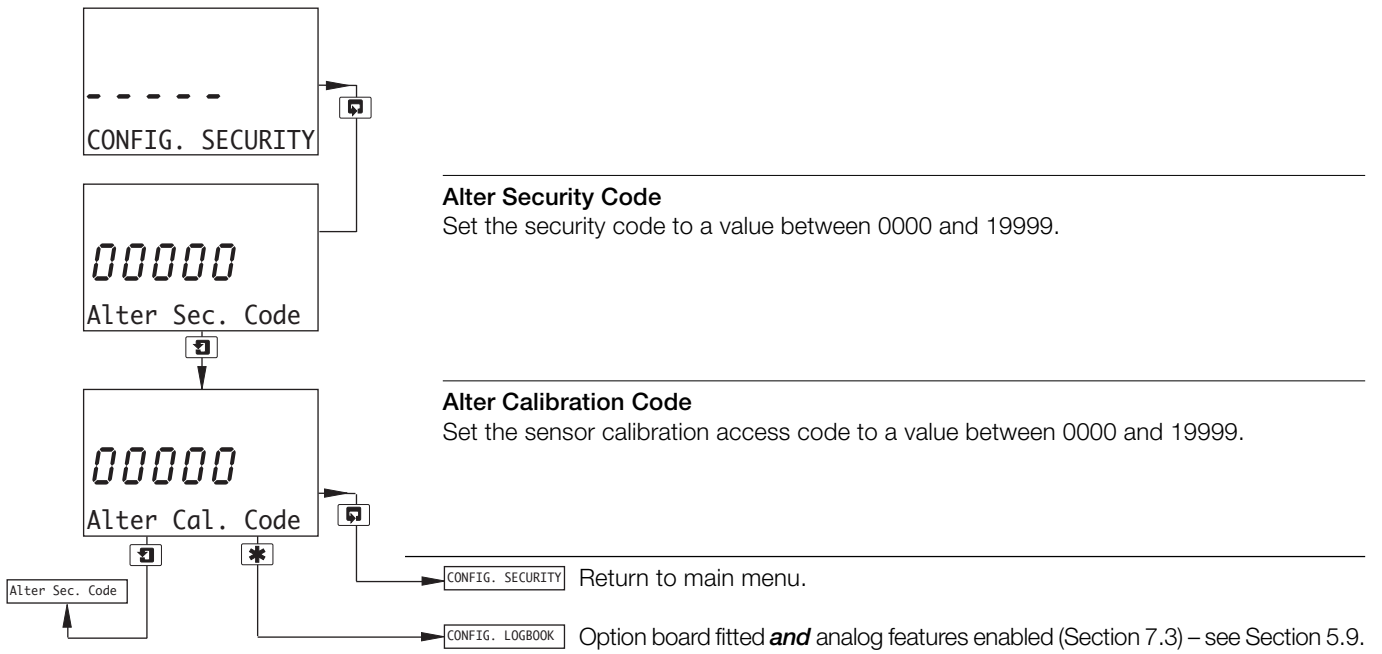

5.9 Configure Logbook

Note. The Configure Logbook function is available only if the option board is fitted *and* analog features enabled – see Section 7.3.

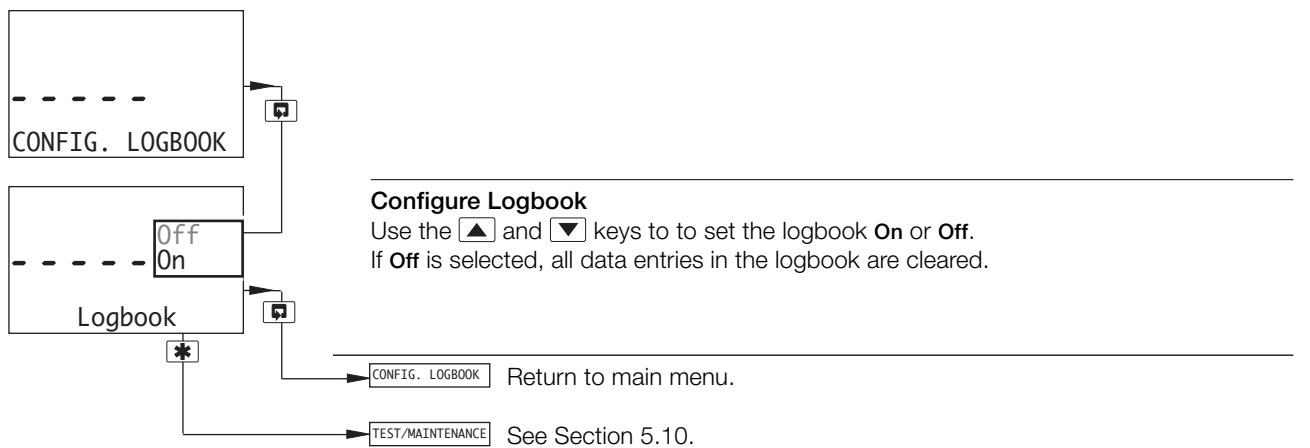

5.10 Test Outputs and Maintenance

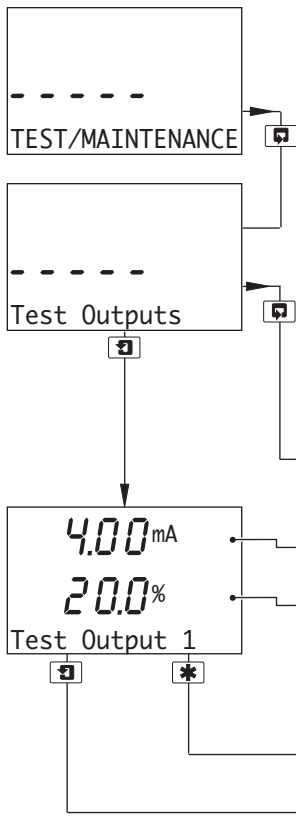

Test Outputs

Displays the output test details for the analog outputs.

Note. Outputs 3 and 4 are available only if the option board is fitted **and** analog features enabled – see Section 7.3.

Test Output 1 frame only is shown; the format of frames for the remaining outputs is identical.

Maintenance See below.

Test Output 1

The theoretical output current value.

Output current as a percentage of the full range current.

Use the ▲ and ▼ keys to adjust the displayed theoretical output current value to give the output required.

FACTORY SETTINGS See Section 7.3.

Test Output 2 Test remaining outputs.

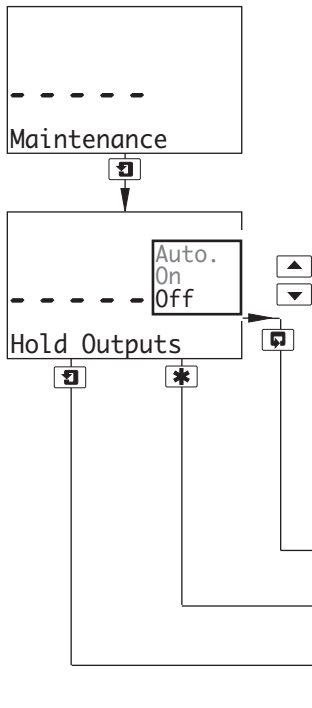

Maintenance

Hold Outputs

Enables the relay action and analog outputs to be maintained.

- Auto. – Changes in relay action and analog outputs are disabled during sensor calibration.
- On – Changes in relay action and analog outputs are disabled.
- Off – Changes in relay action and analog outputs are not disabled.

Note. The LEDs flash while the analyzer is in 'Hold' mode.

Load/Save Config Continued on next page.

FACTORY SETTINGS See Section 7.3.

Maintenance **Hold Outputs** set to **Off** or **On** – return to main menu.

Automatic Time **Hold Outputs** set to **Auto.** – continued on next page.

...5.10 Test Outputs and Maintenance

Hold Outputs
set to Auto.

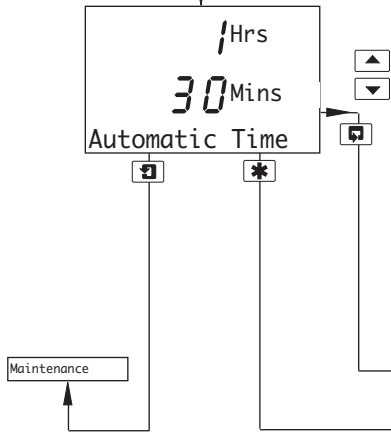

Automatic Time

If required, set a time period between 1 and 6 hours, in 30 minute increments, for which the outputs are held when **Hold Outputs** is set to **Auto**.

At the default setting of **None**, changes in relay action and analog outputs are disabled during sensor calibration and enabled automatically at the end of the procedure.

If a time is set, changes in relay action and analog outputs are disabled during sensor calibration, but if the calibration is not completed within the set time, the calibration is aborted, the display returns to the *Operating Page* and **CAL. ABORTED** is displayed.

Load/Save Config Continued below.

FACTORY SETTINGS See Section 7.3.

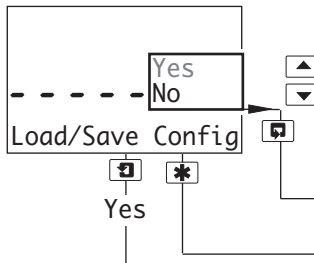

Load/Save Configuration

Select whether a configuration is to be loaded or saved.

Note. If **No** is selected, pressing the key has no effect.

TEST/MAINTENANCE Return to main menu.

FACTORY SETTINGS See Section 7.3.

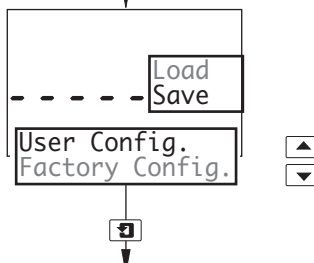

Load User/Factory Configuration

Note. Applicable only if **Load/Save Config** is set to **Yes**.

- Factory Config. – resets all the parameters in the **Configuration Pages** to the Company Standard.
- Save User Config. – saves the current configuration into memory.
- Load User Config. – reads the saved user configuration into memory.

User Config. and **Factory Config.** are displayed alternately if a User Configuration has been saved previously. Use the and keys to make the required selection.

Press to Set and **Press to Abort** are displayed alternately on the lower display line.

Press the appropriate key to load/save the configuration or abort the changes.

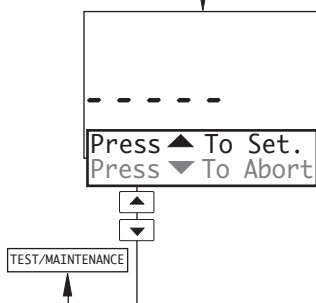

6 INSTALLATION

6.1 Siting Requirements

Notes.

- Mount in a location free from excessive vibration, and where the temperature and humidity specification will not be exceeded.
- Mount away from harmful vapors and/or dripping fluids and ensure that it is suitably protected from direct sunlight, rain, snow and hail.
- Where possible, mount the analyzer at eye level to allow an unrestricted view of the front panel displays and controls.

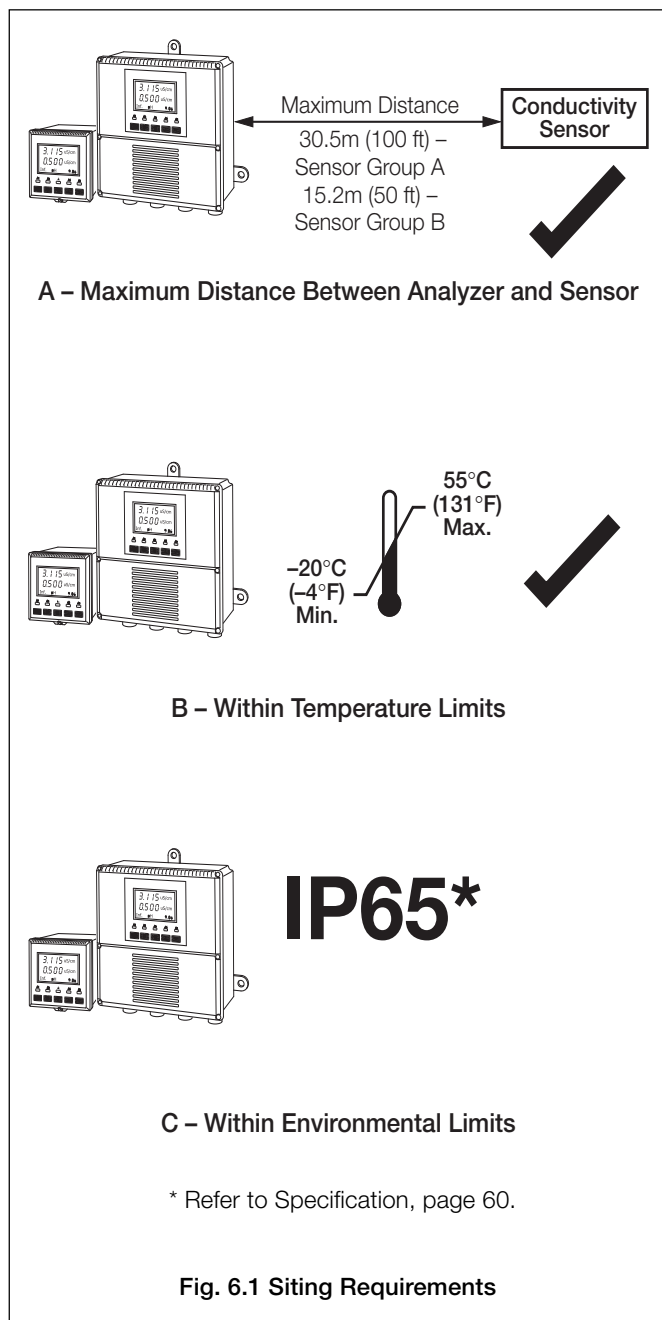

6.2 Mounting

6.2.1 Wall-/Pipe-mount Analyzers – Figs. 6.2 and 6.3

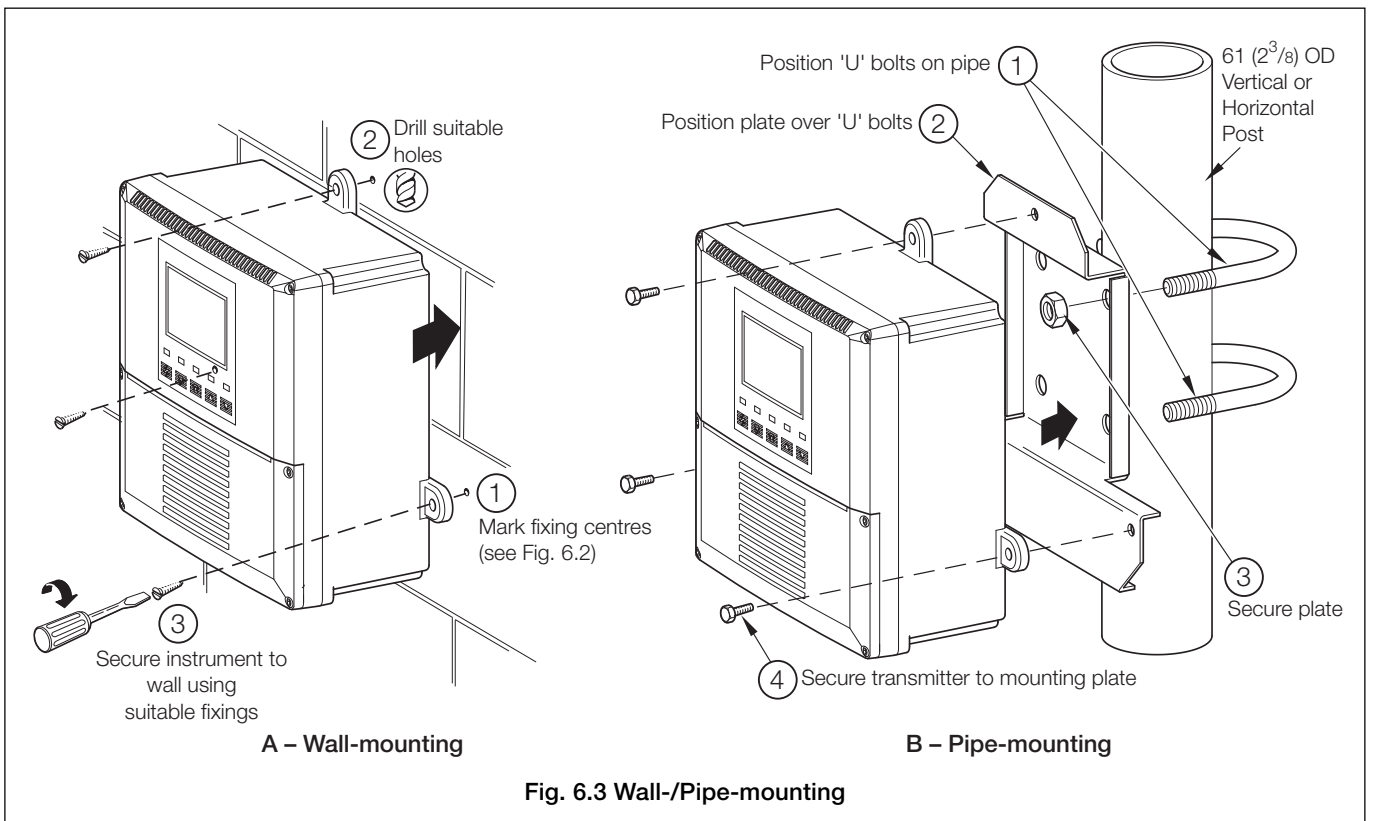
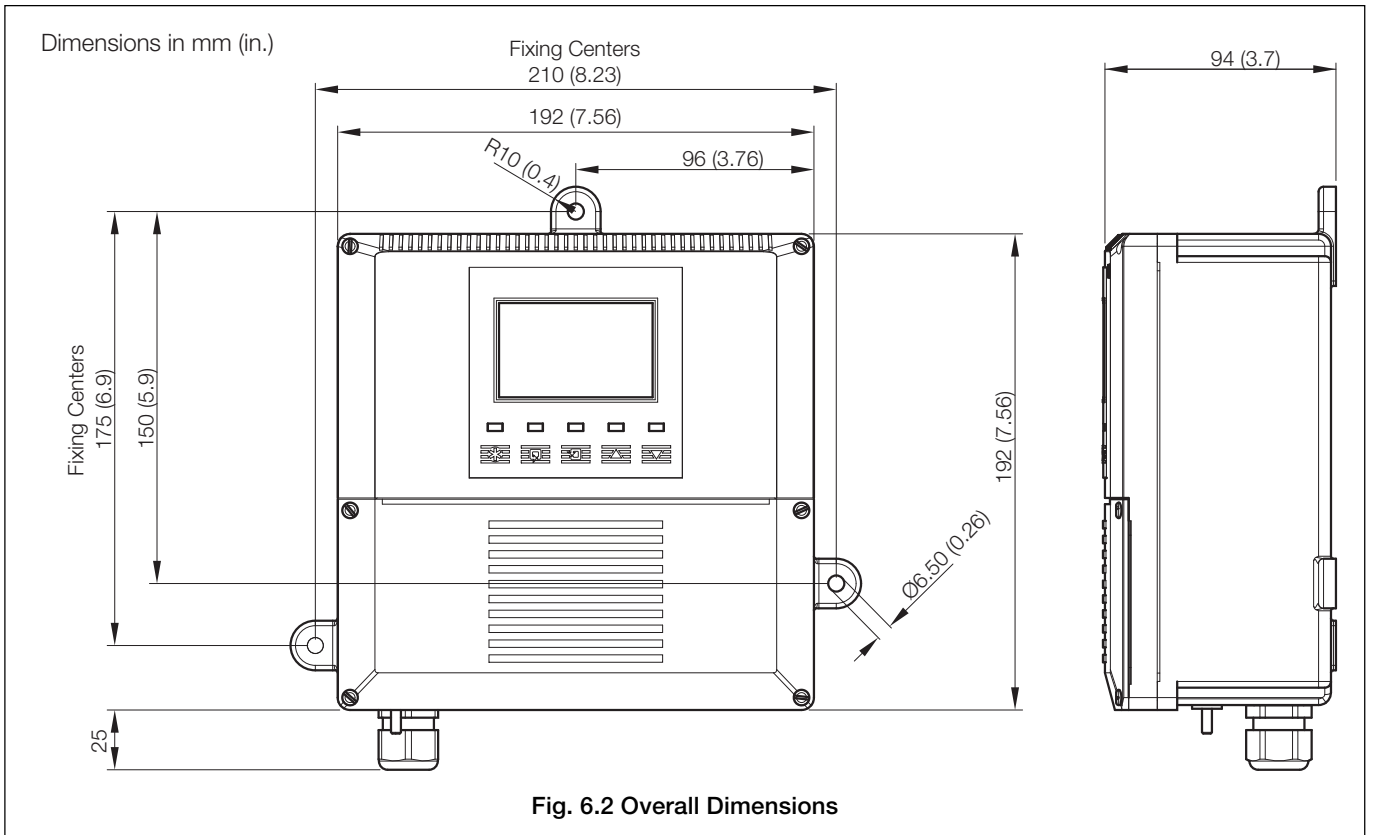

...6 INSTALLATION

...6.2 Mounting

6.2.2 Panel-mount Analyzers – Figs. 6.4 and 6.5

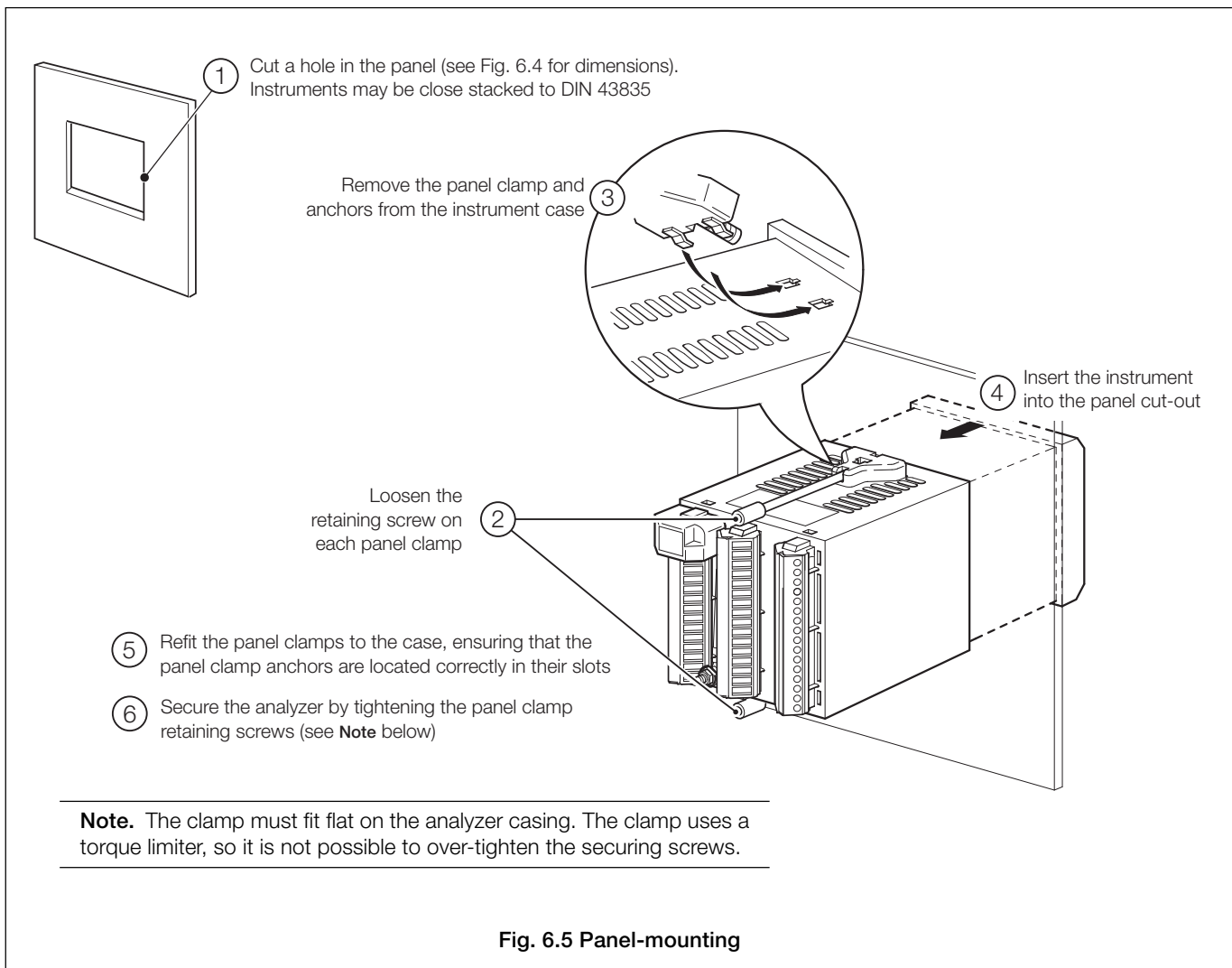
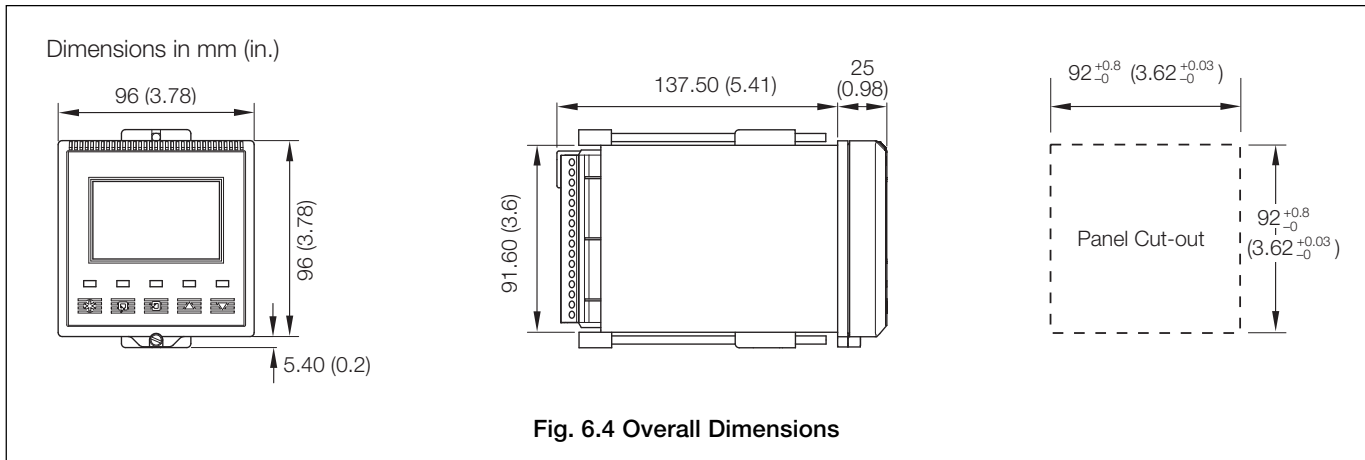

6.3 Electrical Connections



Warnings.

- The instrument is not fitted with a switch therefore a disconnecting device such as a switch or circuit breaker conforming to local safety standards must be fitted to the final installation. It must be fitted in close proximity to the instrument within easy reach of the operator and must be marked clearly as the disconnection device for the instrument.
- Remove all power from supply, relay and any powered control circuits and high common mode voltages before accessing or making any connections.
- The power supply earth (ground) **must** be connected to reduce the effects of RFI interference and ensure the correct operation of the power supply interference filter.
- The power supply earth (ground) **must** be connected to the earth (ground) stud on the analyzer case – see Fig. 6.8 (wall-/pipe-mount analyzers) or Fig. 6.10 (panel-mount analyzers).
- Use cable appropriate for the load currents. The terminals accept cables from 20 to 14 AWG (0.5 to 2.5mm²) UL Category AVLV2.
- The instrument conforms to Mains Power Input Insulation Category III. All other inputs and outputs conform to Category II.
- All connections to secondary circuits must have basic insulation.
- After installation, there must be no access to live parts, e.g. terminals.
- Terminals for external circuits are for use only with equipment with no accessible live parts.
- The relay contacts are voltage-free and must be appropriately connected in series with the power supply and the alarm/control device which they are to actuate. Ensure that the contact rating is not exceeded. Refer also to Section 6.3.1 for relay contact protection details when the relays are to be used for switching loads.
- Do not exceed the maximum load specification for the selected analog output range.
The analog output is isolated, therefore the –ve terminal must be connected to earth (ground) if connecting to the isolated input of another device.
- If the instrument is used in a manner not specified by the Company, the protection provided by the equipment may be impaired.
- All equipment connected to the instrument's terminals must comply with local safety standards (IEC 60950, EN61010-1).

USA and Canada Only

- The supplied cable glands are provided for the connection of signal input and ethernet communication wiring ONLY.
- The supplied cable glands and use of cable / flexible cord for connection of the mains power source to the mains input and relay contact output terminals is not permitted in the USA or Canada.
- For connection to mains (mains input and relay contact outputs), use only suitably rated field wiring insulated copper conductors rated min. 300 V, 14 AWG 90C. Route wires through suitably flexible conduits and fittings.

Notes.

- Earthing (grounding) – a stud terminal is fitted to the analyzer case for bus-bar earth (ground) connection – see Fig. 6.8 (wall-/pipe-mount analyzers) or Fig. 6.10 (panel-mount analyzers).
- Always route signal output/sensor cell cable leads and mains-carrying/relay cables separately, ideally in earthed (grounded) metal conduit. Use twisted pair output leads or screened cable with the screen connected to the case earth (ground) stud.
Ensure that the cables enter the analyzer through the glands nearest the appropriate screw terminals and are short and direct. Do not tuck excess cable into the terminal compartment.
- Ensure that the IP65 rating is not compromised when using cable glands, conduit fittings and blanking plugs/bungs (M20 holes). The M20 glands accept cable of between 5 and 9mm (0.2 and 0.35 in.) diameter.

...6 INSTALLATION

...6.3 Electrical Connections

6.3.1 Relay Contact Protection and Interference Suppression – Fig. 6.6

If the relays are used to switch loads on and off, the relay contacts can become eroded due to arcing. Arcing also generates radio frequency interference (RFI) which can result in analyzer malfunctions and incorrect readings. To minimize the effects of RFI, arc suppression components are required; resistor/capacitor networks for AC applications or diodes for DC applications. These components must be connected across the load – see Fig 6.6.

For **AC applications** the value of the resistor/capacitor network depends on the load current and inductance that is switched. Initially, fit a 100R/0.022 μ F RC suppressor unit (part no. B9303) as shown in Fig. 6.6A. If the analyzer malfunctions (locks up, display goes blank, resets etc.) the value of the RC network is too low for suppression and an alternative value must be used. If the correct value cannot be obtained, contact the manufacturer of the switched device for details on the RC unit required.

For **DC applications** fit a diode as shown in Fig. 6.6B. For general applications use an IN5406 type (600V peak inverse voltage at 3A).

Note. For reliable switching the minimum voltage must be greater than 12V and the minimum current greater than 100mA.

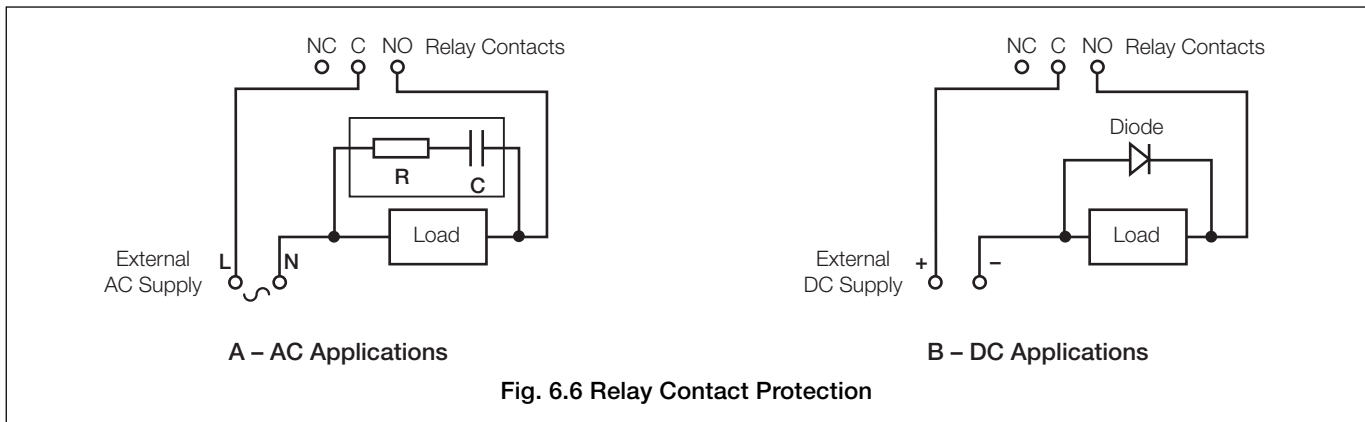

...6.3 Electrical Connections

6.3.2 Cable Entry Knockouts, Wall-/Pipe-mount Analyzer – Fig. 6.7

The analyzer is supplied with 7 cable glands, one fitted and six to be fitted, as required, by the user – see Fig. 6.7.

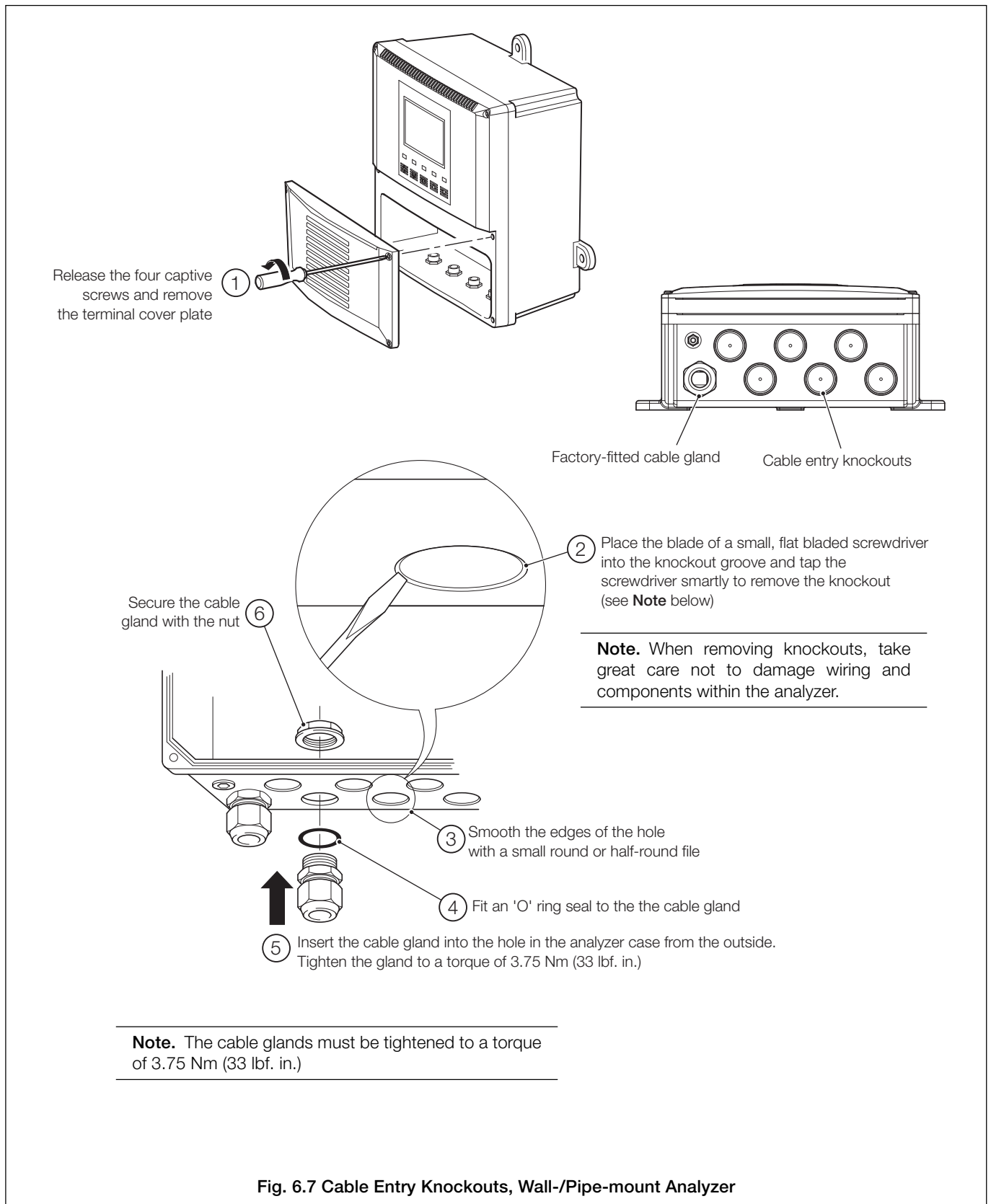

6.4 Wall-/Pipe-mount Analyzer Connections

6.4.1 Access to Terminals – Fig. 6.8

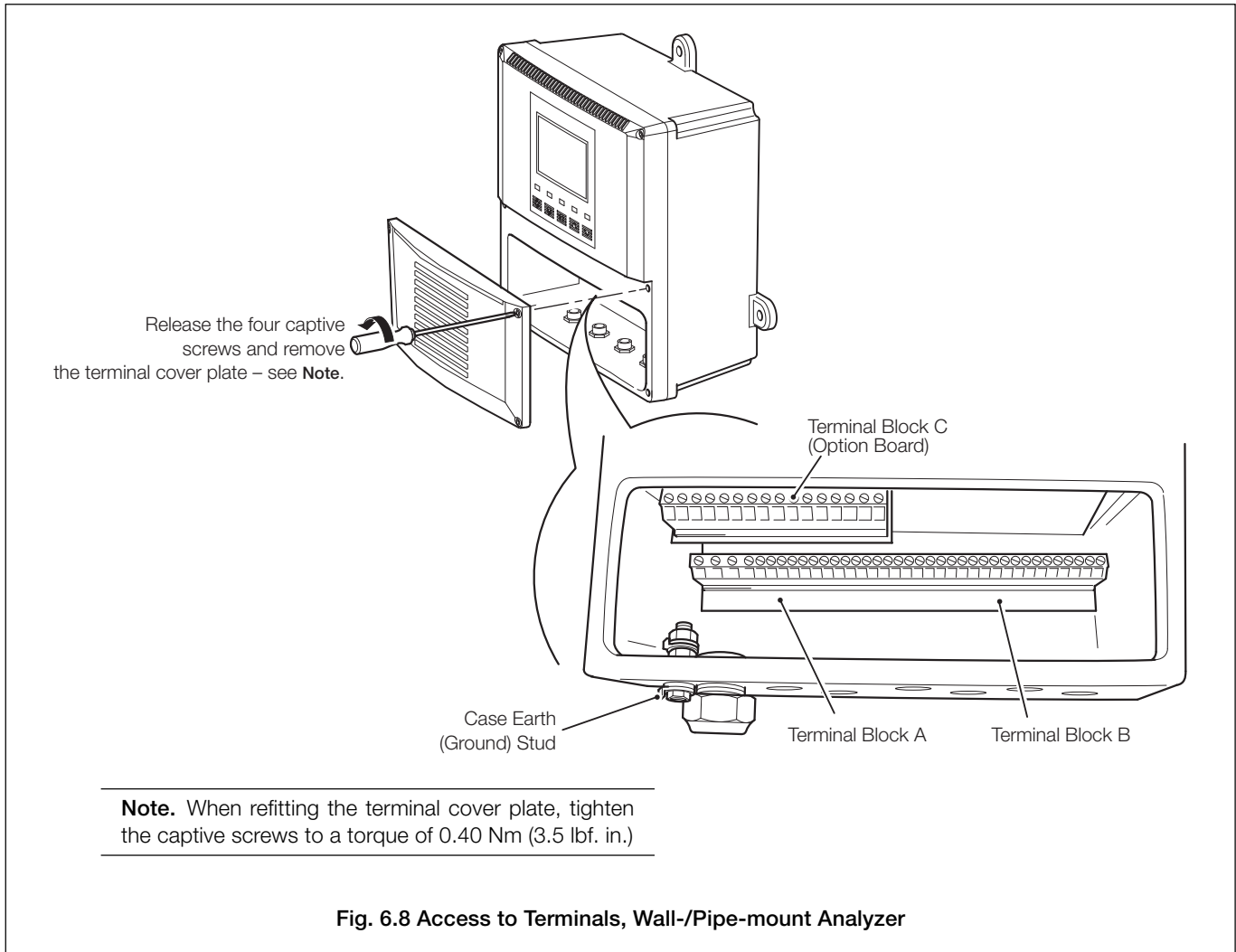

...6.4 Wall-/Pipe-mount Analyzer Connections

6.4.2 Connections – Fig. 6.9

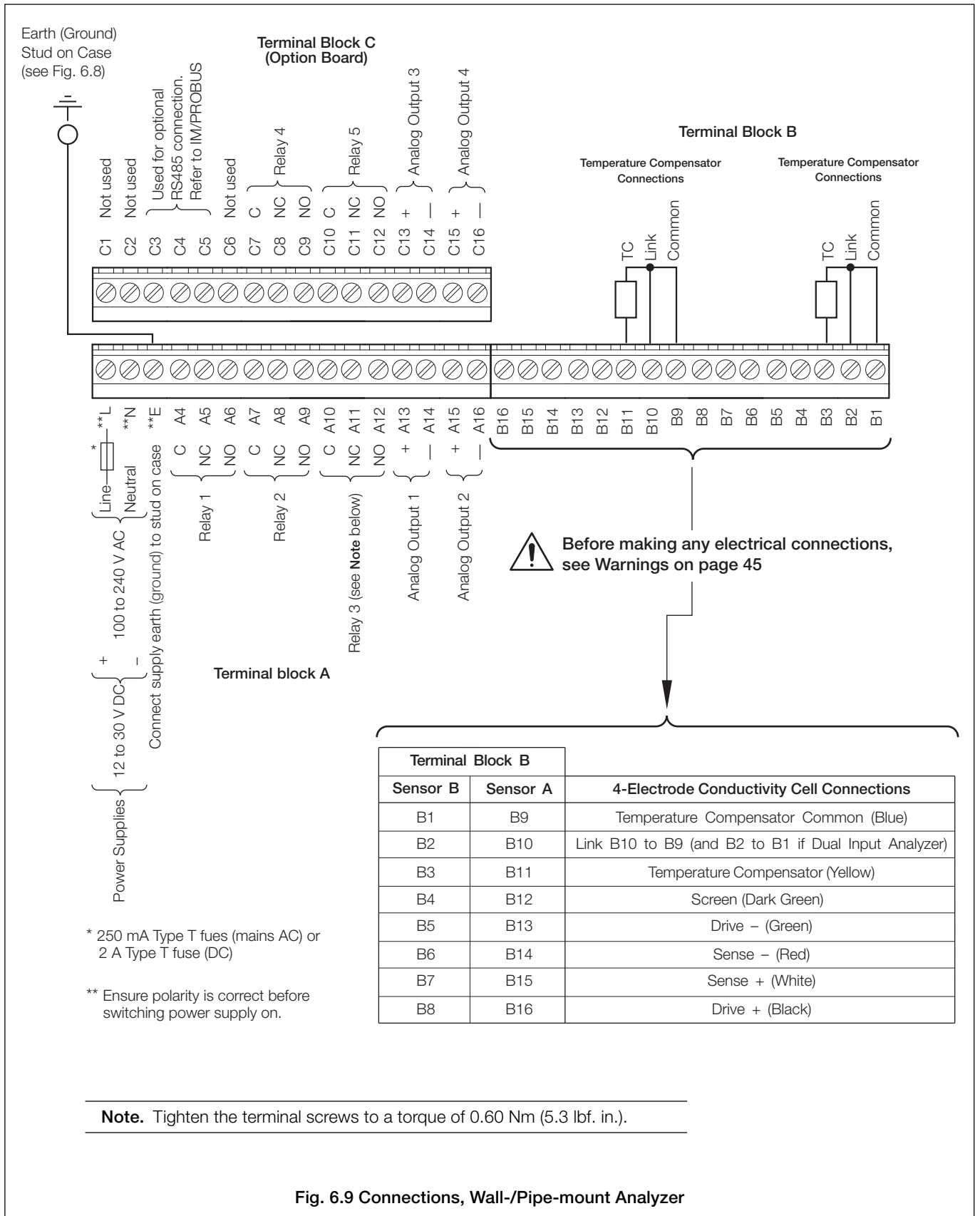

Fig. 6.9 Connections, Wall-/Pipe-mount Analyzer

6.5 Panel-mount Analyzer Connections

6.5.1 Access to Terminals – Fig. 6.10

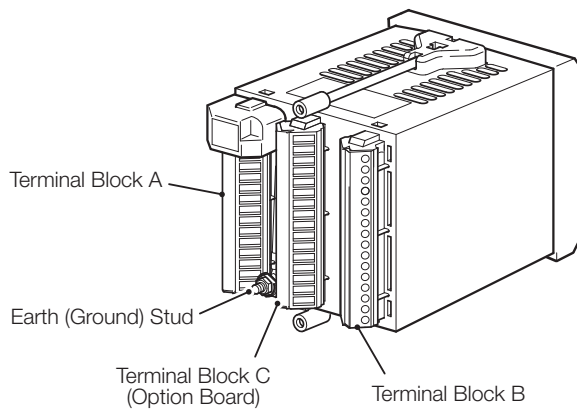

Fig. 6.10 Access to Terminals, Panel-mount Analyzers

...6.5 Panel-mount Analyzer Connections

6.5.2 Connections – Fig. 6.11

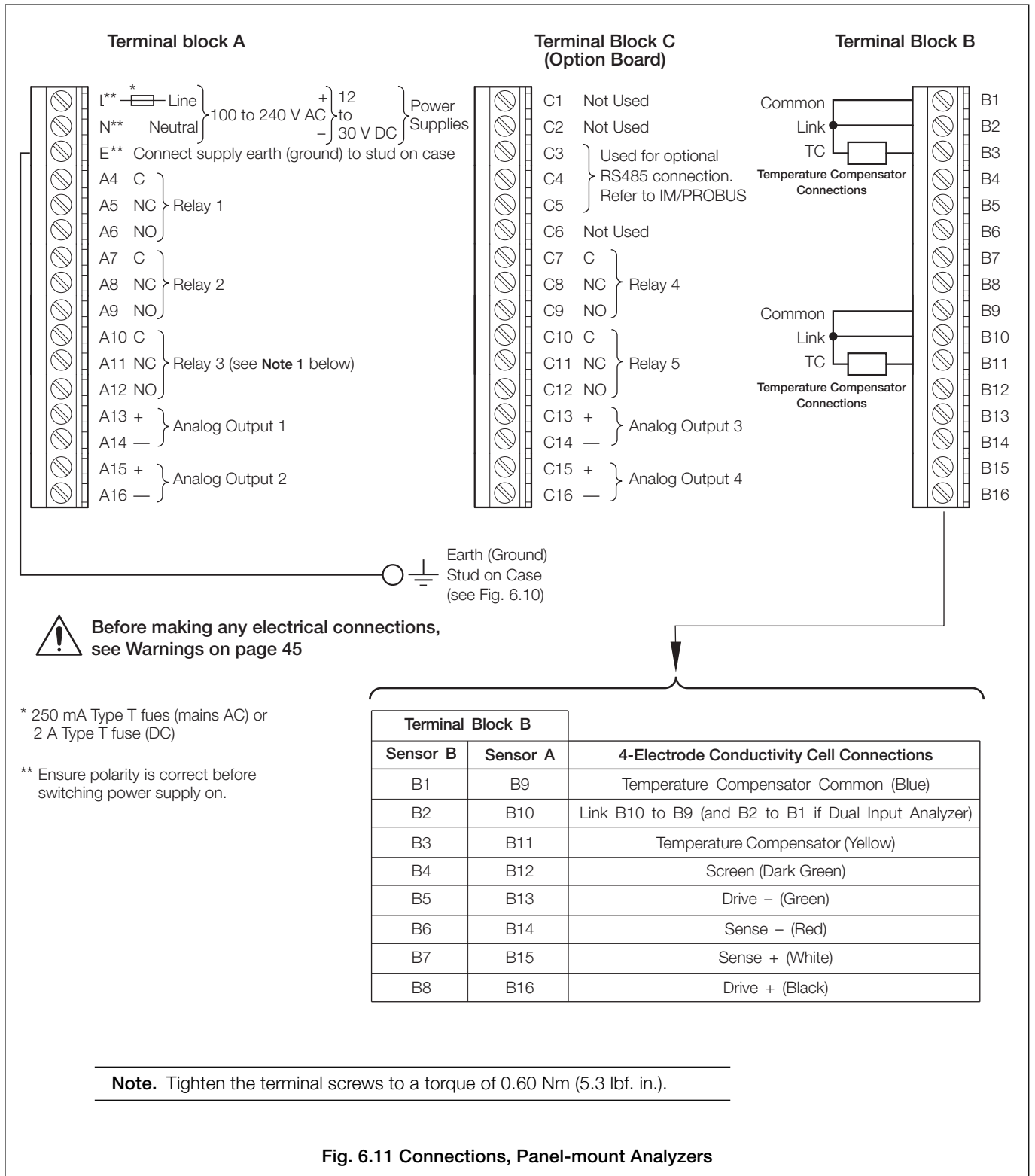

Fig. 6.11 Connections, Panel-mount Analyzers

7 CALIBRATION

Notes.

- The analyzer is calibrated by the Company prior to dispatch and the Factory Settings pages are protected by an access code.
- Routine recalibration is not necessary – high stability components are used in the analyzer's input circuitry and, once calibrated, the Analog-to-Digital converter chip self-compensates for zero and span drift. It is therefore unlikely that the calibration will change over time.
- **Do Not** attempt recalibration without first contacting ABB.
- **Do Not** attempt recalibration unless the input board has been replaced or the Factory Calibration tampered with.
- Before attempting recalibration, test the analyzer's accuracy using suitably calibrated test equipment – see Sections 7.1 and 7.2.

7.1 Equipment Required

- a) Decade resistance box (conductivity cell input simulator): 0 to 100K Ω (in increments of 0.1 Ω), accuracy $\pm 0.1\%$.
- b) Decade resistance box (Pt1000/3K Balco temperature input simulator): 0 to 10K Ω (in increments of 0.1 Ω), accuracy $\pm 0.1\%$.
- c) Digital milliammeter (current output measurement): 0 to 20mA.

Note. Resistance boxes have an inherent residual resistance that may range from a few m Ω up to 1 Ω . This value must be taken into account when simulating input levels, as should the overall tolerance of the resistors within the boxes.

7.2 Preparation

- a) Switch off the supply and disconnect the conductivity cell(s), temperature compensator(s) and current output(s) from the analyzer's terminal blocks.
- b) Sensor A – Fig 7.1:
 - 1) Link terminals B9 and B10.
 - 2) Connect one terminal of the 0 to 100K Ω decade resistance box to B13 and B14 and the other terminal to B15 and B16 to simulate the conductivity cell. Connect the decade resistance box earth to B12.
 - 3) Connect the 0 to 10K Ω decade resistance box to B9 and B11 to simulate the Pt1000/3K Balco.

Sensor B (dual input analyzers only) – Fig 7.1:

- 1) Link terminals B1 and B2.
 - 2) Connect one terminal of the 0 to 100K Ω decade resistance box to B5 and B6 and the other terminal to B7 and B8 to simulate the conductivity cell. Connect the decade resistance box earth to B4.
 - 3) Connect the 0 to 10K Ω decade resistance box to B1 and B3 to simulate the Pt1000/3K Balco.
- c) Connect the milliammeter to the analog output terminals.
 - d) Switch on the supply and allow ten minutes for the circuits to stabilize.
 - d) Select the **FACTORY SETTINGS** page and carry out Section 7.3.

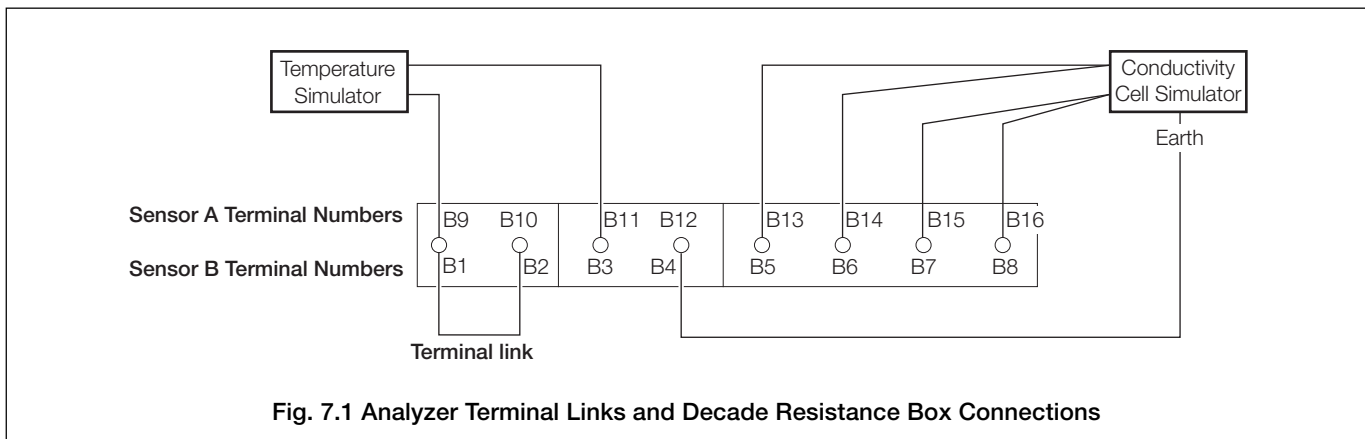

Fig. 7.1 Analyzer Terminal Links and Decade Resistance Box Connections

7.3 Factory Settings

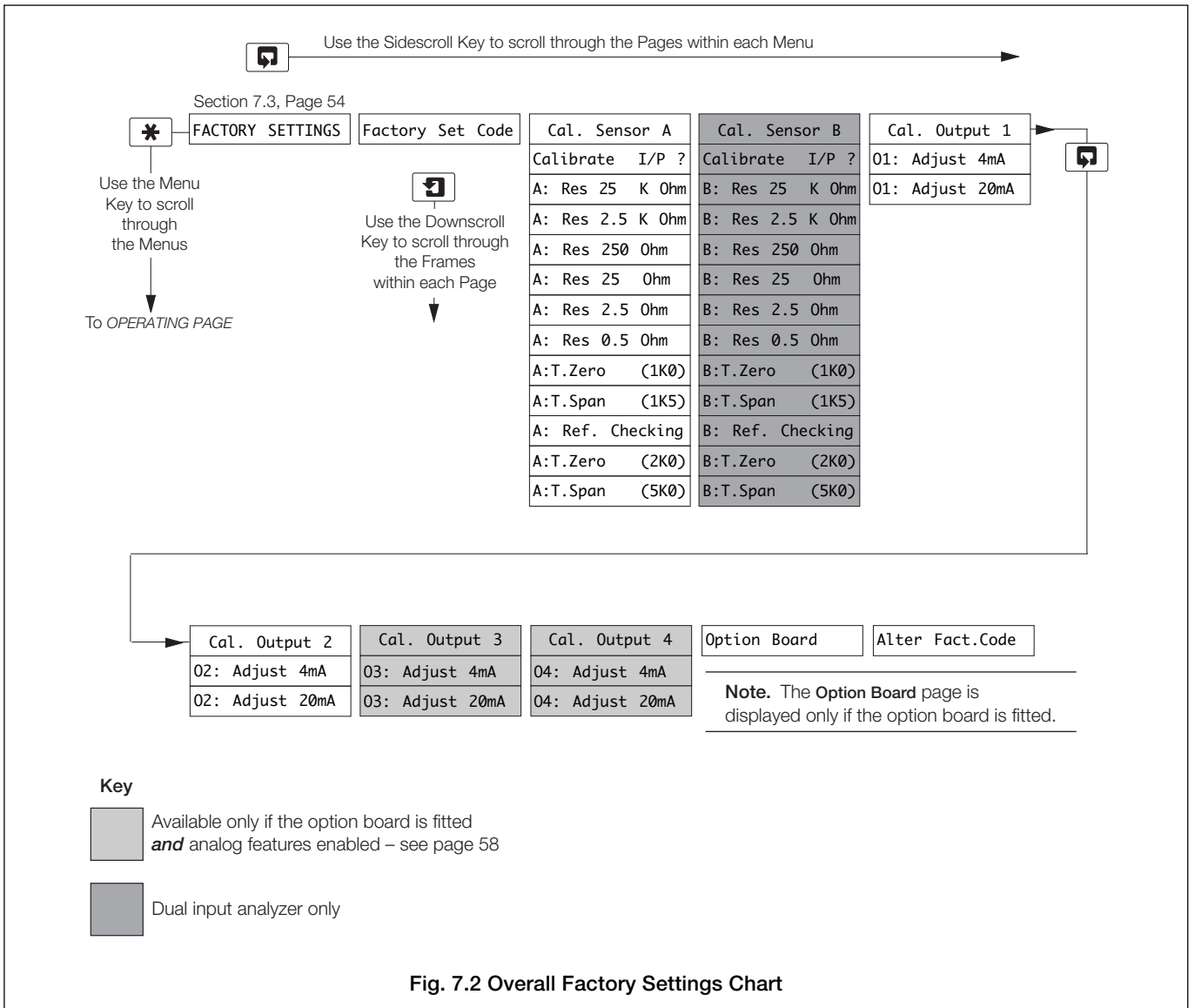
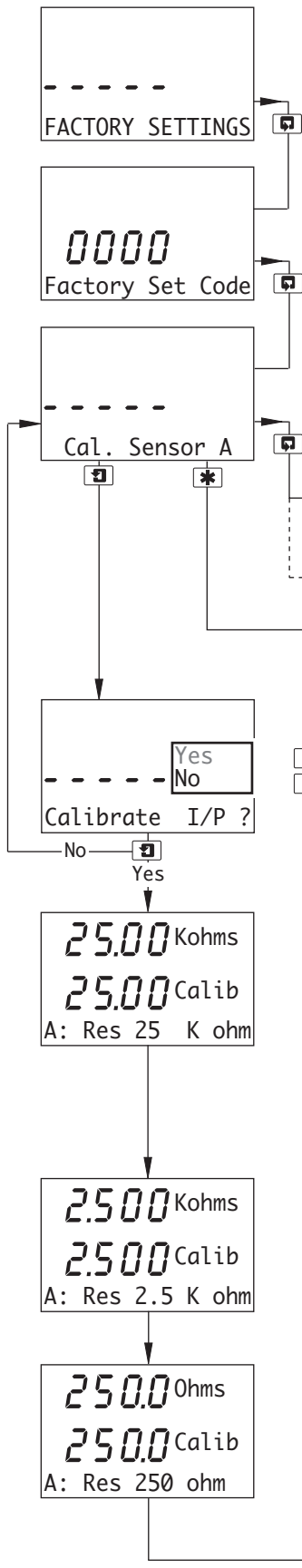

Fig. 7.2 Overall Factory Settings Chart

...7.3 Factory Settings



Factory Settings Access Code

Enter the required code number, between 0000 and 19999, to gain access to the factory settings. If an incorrect value is entered, access to subsequent frames is prevented and the display reverts to the top of the page.

Calibrate Sensor A

Note. The values in the display lines for sensor calibration are shown as examples only – the actual values obtained will differ.

Cal. Sensor B Sensor B calibration (dual input analyzers only) is identical to Sensor A calibration.

Cal. Output 1 Single input analyzers only – see page 57.

Conductivity } Operating Page – see Section 2.3.
Dual Cond.

Calibrate Input for Sensor A ?

If calibration is required select **Yes** otherwise select **No**.

Note. To abort calibration, press the key again at any time before calibration is complete – see next page.

Resistance Span (25KΩ)

Set the cell simulator to 25KΩ.

The display advances automatically to the next step once a stable and valid value is recorded.

Note. The upper 7-segment display shows the measured voltage. Once the signal is within range the lower 7-segment display shows the same value and **Calib** is displayed to indicate that calibration is in progress.

Resistance Span (2.5KΩ)

Set the cell simulator to 2.5KΩ.

The display advances automatically to the next step once a stable and valid value is recorded.

Resistance Span (250Ω)

Set the cell simulator to 250Ω.

The display advances automatically to the next step once a stable and valid value is recorded.

A: Res 25 ohm Continued on next page.

...7.3 Factory Settings

25.00 Ohms
25.00 Calib
A: Res 25 ohm

2.500 Ohms
2.500 Calib
A: Res 2.5 ohm

0.500 Ohms
0.500 Calib
A: Res 0.5 ohm

1000 Ohms
1000 Calib
A:T.Zero (1K0)

1500 Ohms
1500 Calib
A:T.Span (1K5)

Resistance Span (25Ω)

Set the cell simulator to 25Ω.

The display advances automatically to the next step once a stable and valid value is recorded.

Resistance Span (2.5Ω)

Set the cell simulator to 2.5Ω.

The display advances automatically to the next step once a stable and valid value is recorded.

Resistance Span (0.5Ω)

Set the cell simulator to 0.5Ω.

The display advances automatically to the next step once a stable and valid value is recorded.

Temperature Zero (1KΩ)

Set the temperature simulator to 1KΩ.

The display advances automatically to the next step once a stable and valid value is recorded.

Temperature Span (1.5KΩ)

Set the temperature simulator to 1.5KΩ.

The display advances automatically to the next step once a stable and valid value is recorded.

A: Ref. Checking

Continued on next page.

...7 CALIBRATION

...7.3 Factory Settings

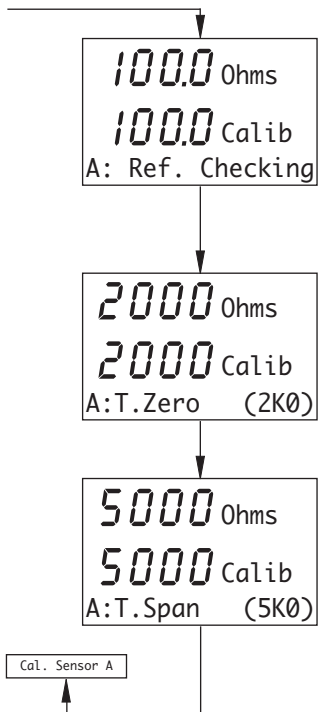

Reference Resistance Checking

The analyzer calibrates the internal reference resistance automatically to compensate for changes in ambient temperatures.

The display advances automatically to the next step once a stable and valid value is recorded.

Temperature Zero (2KΩ)

Set the temperature simulator to 2KΩ.

The display advances automatically to the next step once a stable and valid value is recorded.

Temperature Span (5KΩ)

Set the temperature simulator to 5KΩ.

The display returns automatically to **Cal. Sensor A** once a stable and valid value is recorded.

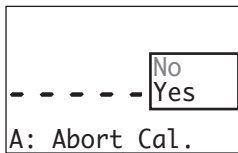

Abort Calibration

Select Yes or No

Yes selected:

– before completion of **A: Res 0.5 ohm** frame – calibration advances to **A:T.Zero (1K0)** and continues.

– after completion of **A: Res 0.5 ohm** frame – the display returns to the **Calibrate Sensor A** page.

No selected – calibration continues from the point at which the **[F1]** key was pressed.

...7.3 Factory Settings

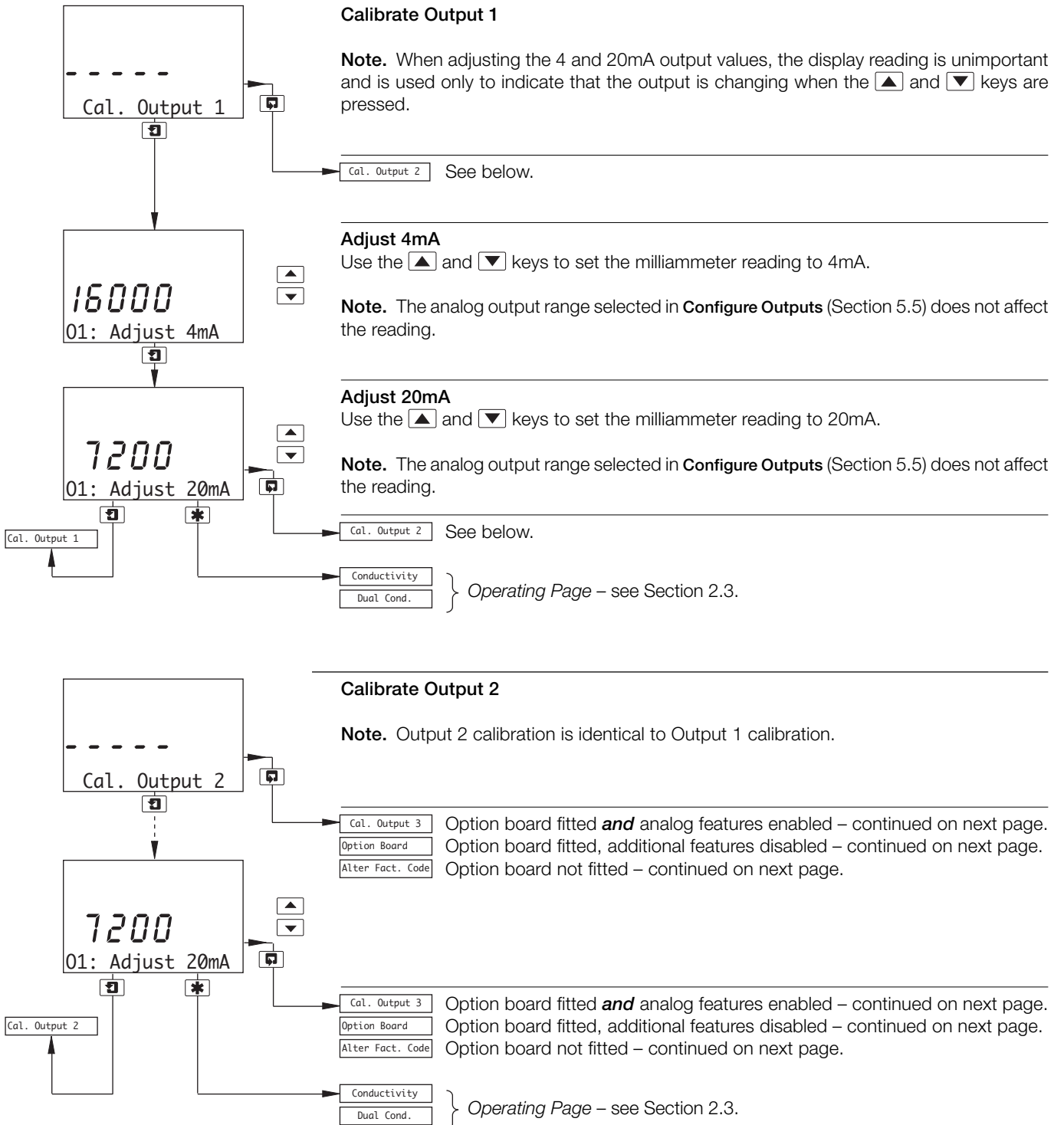

...7.3 Factory Settings

Option Board Fitted **and** Analog Features Enabled

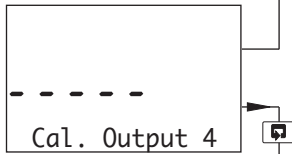
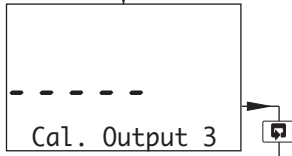

Option Board Fitted, Additional Features Disabled

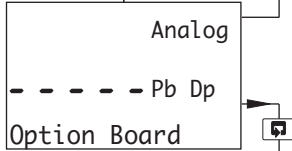

Option Board Not Fitted

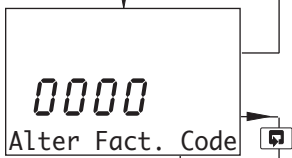

Calibrate Output 3

Notes.

- Output 3 (and Output 4) calibration is applicable only if the option board is fitted **and** analog features enabled – see below.
- Output 3 calibration is identical to Output 2 calibration.

Calibrate Output 4

Note. Output 4 calibration is identical to Output 3 calibration.

Configure Option Board

Notes.

- This frame is displayed only if an option board is fitted.
- The software detects if an option board is fitted but cannot detect the additional features available.
- If an option board is fitted, the correct selection must be made below to enable use of the available features. If an incorrect selection is made, the software menus and frames associated with that option are displayed in the Operating and Configuration pages but the features do not work.

Use the ▲ and ▼ keys to enable the features for the type of option board(s) fitted:

- Analog – Analog features enabled (comprising two additional analog outputs, two additional alarm relays, clock and logbook facility).
- Pb Dp – PROFIBUS-DP digital communications features enabled.
- Analog + Pb Dp – Both analog and PROFIBUS-DP features enabled.

Alter Factory Code

Set the factory settings access code to a value between 0000 and 19999.

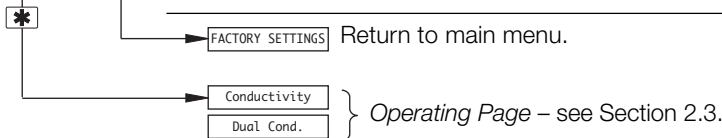

8 SIMPLE FAULT FINDING

8.1 Error Messages

If erroneous or unexpected results are obtained the fault may be indicated in the *Operating Page* by an error message – see Table 8.1. However, some faults may cause problems with analyzer calibration or give discrepancies when compared with independent laboratory measurements.

Error Message	Possible Cause
A: FAULTY Pt1000 A: FAULTY Balco	Temperature compensator/associated connections for Sensor A are either open circuit or short circuit.
B: FAULTY Pt1000 B: FAULTY Balco	Temperature compensator/associated connections for Sensor B are either open circuit or short circuit.

Table 8.1 Error Messages

8.2 No Response to Conductivity Changes

The majority of problems are associated with the conductivity cell which must be cleaned as an initial check. It is also important that all program parameters have been set correctly and have not been altered inadvertently – see Section 5.

If the above checks do not resolve the fault:

- Check the analyzer responds to a resistance input. Disconnect the conductivity cell cable and connect a suitable resistance box directly to the analyzer input – see Section 7.2. Select the **CONFIG. SENSORS** page and set **Temp.Comp.** to **None** – see Section 5.3. Check the analyzer displays the correct values as set on the resistance box – see Table 8.2 or use the expression:

$$R = \frac{K \times 10^6}{G}$$

Where: R = resistance

K = cell constant – 0.5 for TB4 Group A cells
0.05 for TB4 Group B cells
1.0 for AC400 cells

G = conductivity ($\mu\text{S}/\text{cm}$)

Failure to respond to the input indicates a fault with the analyzer which must be returned to the Company for repair. A response, but with incorrect readings, usually indicates an electrical calibration problem. Re-calibrate the analyzer as detailed in Section 7.3.

- If the response in a) is correct, reconnect the conductivity cell cable and connect the resistance box to the cell end. Check the analyzer displays the correct values as set on the resistance box in this configuration.

If the analyzer passes check a) but fails check b), check the cable connections and condition. If the response for both checks is correct, replace the conductivity cell.

Conductivity (G)	Resistance (R)		
	TB4 Group A Sensors	TB4 Group B Sensors	AC400 Sensors
1 $\mu\text{S cm}^{-1}$	500K Ω	50K Ω	1M Ω
5 $\mu\text{S cm}^{-1}$	100K Ω	10K Ω	200k Ω
10 $\mu\text{S cm}^{-1}$	50K Ω	5K Ω	100k Ω
50 $\mu\text{S cm}^{-1}$	10K Ω	1K Ω	20k Ω
100 $\mu\text{S cm}^{-1}$	5K Ω	500 Ω	10k Ω
500 $\mu\text{S cm}^{-1}$	1K Ω	100 Ω	2k Ω
1000 $\mu\text{S cm}^{-1}$	500 Ω	50 Ω	1k Ω
5000 $\mu\text{S cm}^{-1}$	100 Ω	10 Ω	200 Ω
10.0mS cm^{-1}	50 Ω	5 Ω	100 Ω
50.0mS cm^{-1}	10 Ω	1 Ω	20 Ω
100.0mS cm^{-1}	5 Ω	0.5 Ω	10 Ω

Table 8.2 Conductivity Readings for Resistance Inputs

8.3 Checking the Temperature Input

Check the analyzer responds to a temperature input. Disconnect the Pt1000/3K Balco leads and connect a suitable resistance box directly to the analyzer inputs – see Section 7.2. Check the analyzer displays the correct values as set on the resistance box – see Table 8.3.

Incorrect readings usually indicate an electrical calibration problem. Re-calibrate the analyzer as detailed in Section 7.3.

Temperature		Input Resistance (Ω)	
$^{\circ}\text{C}$	$^{\circ}\text{F}$	Pt1000	3K Balco
0	32	1000.0	2663
10	50	1039.0	2798
20	68	1077.9	2933
25	77	1097.3	3000
30	86	1116.7	3068
40	104	1155.4	3203
50	122	1194.0	3338
60	140	1232.4	3473
70	158	1270.7	3608
80	176	1308.9	3743
90	194	1347.0	3878
100	212	1385.0	4013
130.5	267	1500	4424

Table 8.3 Temperature Readings for Resistance Inputs

SPECIFICATION

Specification

Conductivity

Range

Conductivity Programmable	0.000 ... 1999 mS cm ⁻¹ (uncompensated)
Concentration	0.000 ... 1.999 digits (user configurable)
Selectable concentration ranges	0 ... 15% NaOH 0 ... 18% HCl 0 ... 20% H ₂ SO ₄ 0 ... 40% H ₃ PO ₄ 0 ... 20% NaCl User-defined table
Temperature	-20 ... 300 °C (-4 ... 572 °F)

Sensor Full Scale Measurement Ranges

(a) TB4 Group A and AC400 cells	0 ... 1,999 mS cm ⁻¹ (uncompensated)
(b) TB4 Group B cells	0 ... 1,999 μS cm ⁻¹ (uncompensated)

Minimum span

(a) TB4 Group A and AC400 cells	100.0 μS cm ⁻¹
(b) TB4 Group B cells	10.00 μS cm ⁻¹
Concentration	5% of the maximum set concentration range
Temperature	10 °C (50 °F)

Note. Refer to corresponding data sheets for process limit specifications of TB4 and AC400 cells.

Resolution, Display

Conductivity	
(a) TB4 Group A and AC400 cells	0.1 μS cm ⁻¹ 0.1 mS cm ⁻¹
(b) TB4 Group B cells	0.01 μS cm ⁻¹
Concentration	0.001 digits (configuration dependent)
Temperature	0.1 °C (0.1 °F)

Accuracy, Display

Conductivity	±0.5% measurement range per decade
Temperature	10 °C (21 °F)

Display temperature range

-20 ... 300 °C (4 ... 572 °F)

Temperature sensor

Pt1000 or 3k Balco

Temperature coefficient

Programmable 0 ... 9.99%/ °C and fixed temperature compensation curves (programmable) for acids and neutral salt

Reference temperature

25 °C (77 °F)

Dosing control functions

Long-dose alarm	0 ... 10 mins. (user-configurable)
Initial charge function	0 ... 30 mins. (user-configurable)

Display

Type

Dual 5-digit, 7-segment backlit LCD

Information

16-character, single line dot-matrix

Energy-saving function

Backlit LCD configurable as ON or Auto-Off after 60s

Logbook*

Electronic record of major process events and calibration data

Real-time clock*

Records time for logbook and auto-manual functions

*Available if option board is fitted.

Retransmission outputs

2 (4 optional) fully-isolated standard

Relay Outputs – On/Off

Number of relays

Three supplied as standard or five with option board fitted

Number of set points

Three supplied as standard or five with option board fitted

Set point adjustment

Configurable as normal or failsafe high/low, bandwidth alarm (composite high/low) or diagnostic alert

Hysteresis of reading

Programmable 0 ... 5% in 0.1% increments

Delay

Programmable 0 ... 60s in 1s intervals

Relay contacts

Single-pole changeover

Rating 5 A, 115/230 V AC, 5 A DC

Insulation

2 kV RMS contacts to earth/ground

Analog Outputs

Number of current outputs (fully isolated)

Two supplied as standard or four with option board fitted

Output range

0 ... 10 mA, 0 ... 20 mA or 4 ... 20 mA

Analog output programmable to any value between 0 and 22 mA to indicate system failure

Accuracy

±0.25% FSD, ±0.5% of reading (whichever is the greater)

Resolution

0.1% at 10 mA, 0.05% at 20 mA

Maximum load resistance

750Ω at 20 mA

Configuration

Can be assigned to either measured variable or either sample temperature

Digital Communications

Communications

Profibus DP (with option board fitted)

Control Function – AX430 Only

Controller Type

P, PI, PID (configurable)

Control Outputs

Analog

Current output control (0 ... 100%)

Time proportioning cycle time

1.0 ... 300.0s, programmable in increments of 0.1s

Pulse frequency

1 ... 120 pulses per minute, programmable in increments of 1 pulse per minute

Controller action

Direct or reverse

Proportional band

0.1 ... 999.9%, programmable in increments of 0.1%

Integral action time (Integral reset)

1 ... 7200s, programmable in increments of 1s (0 = Off)

Derivative

0.1 ... 999.9s in increments of 0.1s
available only for single set point control

Auto/Manual

User-programmable

Access to Functions

Direct keypad access

Measurement, maintenance, configuration, diagnostics or service functions

Performed without external equipment or internal jumpers

Mechanical Data

Wall-/Pipe-mount versions

IP65 (not evaluated under UL certification)

Dimensions (height, width, depth)

192 x 230 x 94 mm (7.56 x 9.06 x 3.7 in)

Weight 1kg (2.2 lb)

Panel-mount versions

IP65 (front only)

Dimensions (height, width, depth)

96 x 96 x 162 mm (3.78 x 3.78 x 6.38 in)

Weight 0.6kg (1.32 lb)

Cable Entry Types

Standard 5 or 7 x M20 cable glands

North American 7 x knockouts suitable for 1/2 in. Hubble gland

Power Supply

Voltage requirements

100 to 240 V AC 50/60 Hz
(90 V Min. to 264 V Max. AC)

12 to 30 V DC

Power consumption

10 W

Insulation

Mains to earth (line to ground) 2 kV RMS

Environmental Data

Operating temperature limits

-20 to 55°C (-4 ... 131°F)

Storage temperature limits

-25 ... 75°C (-13 ... 167°F)

Operating humidity limits

Up to 95% RH non condensing

EMC

Emissions and immunity

Meets requirements of:

EN61326 (for an industrial environment)

EN50081-2

EN50082-2

Approvals, Certification and Safety

Safety approval

UL

CE Mark

CE Mark

Covers EMC & LV Directives (including latest version EN 61010)

General safety

EN61010-1

Overvoltage Class II on inputs and outputs

Pollution category 2

Languages

Languages configurable:

English

French

German

Italian

Spanish

APPENDIX A

A1 Automatic Temperature Compensation

The conductivities of electrolytic solutions are influenced considerably by temperature variations. Thus, when significant temperature fluctuations occur, it is general practice to correct automatically the measured, prevailing conductivity to the value that would apply if the solution temperature were 25°C, the internationally accepted standard.

Most commonplace, weak aqueous solutions have temperature coefficients of conductance of the order of 2% per °C (i.e. the conductivities of the solutions increase progressively by 2% per °C rise in temperature); at higher concentrations the coefficient tends to become less.

At low conductivity levels, approaching that of ultra-pure water, dissociation of the H₂O molecule takes place and it separates into the ions H⁺ and OH⁻. Since conduction occurs only in the presence of ions, there is a theoretical conductivity level for ultra-pure water which can be calculated mathematically. In practice, correlation between the calculated and actual measured conductivity of ultra-pure water is very good.

The generally accepted expression relating conductivity and temperature is:

$$G_t = G_{25} [1 + \alpha (t - 25)]$$

Where: G_t = conductivity at the temperature t °C

G_{25} = conductivity at the standard temperature (25°C)

α = temperature coefficient per °C

When making temperature compensated measurements, a conductivity analyzer must carry out the following computation to obtain G_{25} :

$$G_{25} = \frac{G_t}{[1 + \alpha (t - 25)]}$$

A1.1 Calculation of Temperature Coefficient

The temperature coefficient of a solution can be obtained experimentally by taking non-temperature compensated conductivity measurements at two temperatures and applying the following expression:

$$\alpha = \frac{G_{t_2} - G_{t_1}}{G_{t_1} (t_2 - 25) - G_{t_2} (t_1 - 25)}$$

Where: G_{t_2} = conductivity measurement at a temperature of t_2 °C

G_{t_1} = conductivity measurement at a temperature of t_1 °C

One of these measurements could be made at the ambient temperature and the other obtained by heating the sample.

Temperature coefficient (%/°C) = $\alpha \times 100$.

APPENDIX B

B1 Single PID Controller – Fig. B1

The single PID controller is a basic feedback control system using three-term PID control with a local set point.

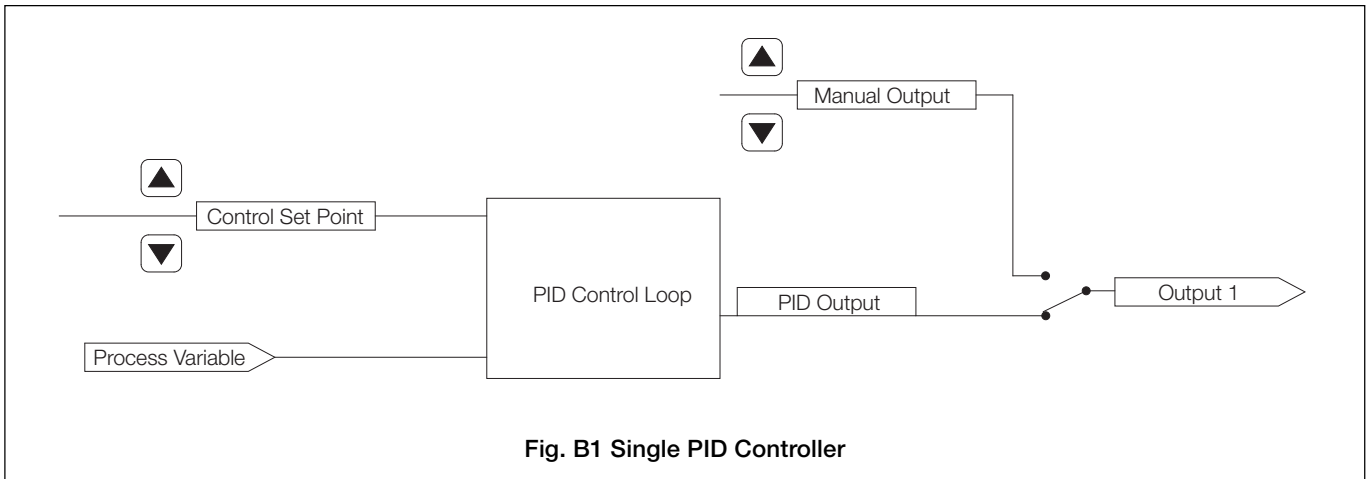

B1.1 Reverse Acting Single PID Control – Fig. B2

Reverse acting control is used when the process conductivity is less than the required output conductivity.

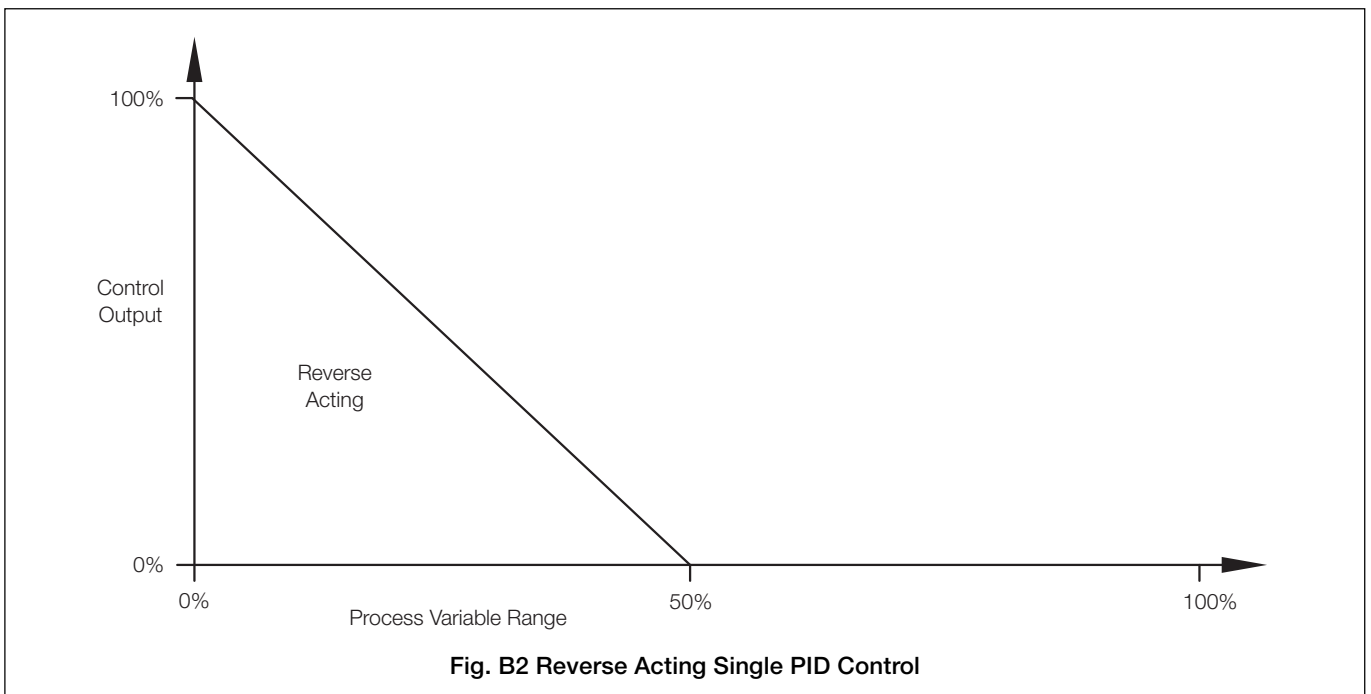

B1.2 Direct Acting Single PID Control – Fig. B3

Direct acting control is used when the process conductivity is greater than the required output conductivity.

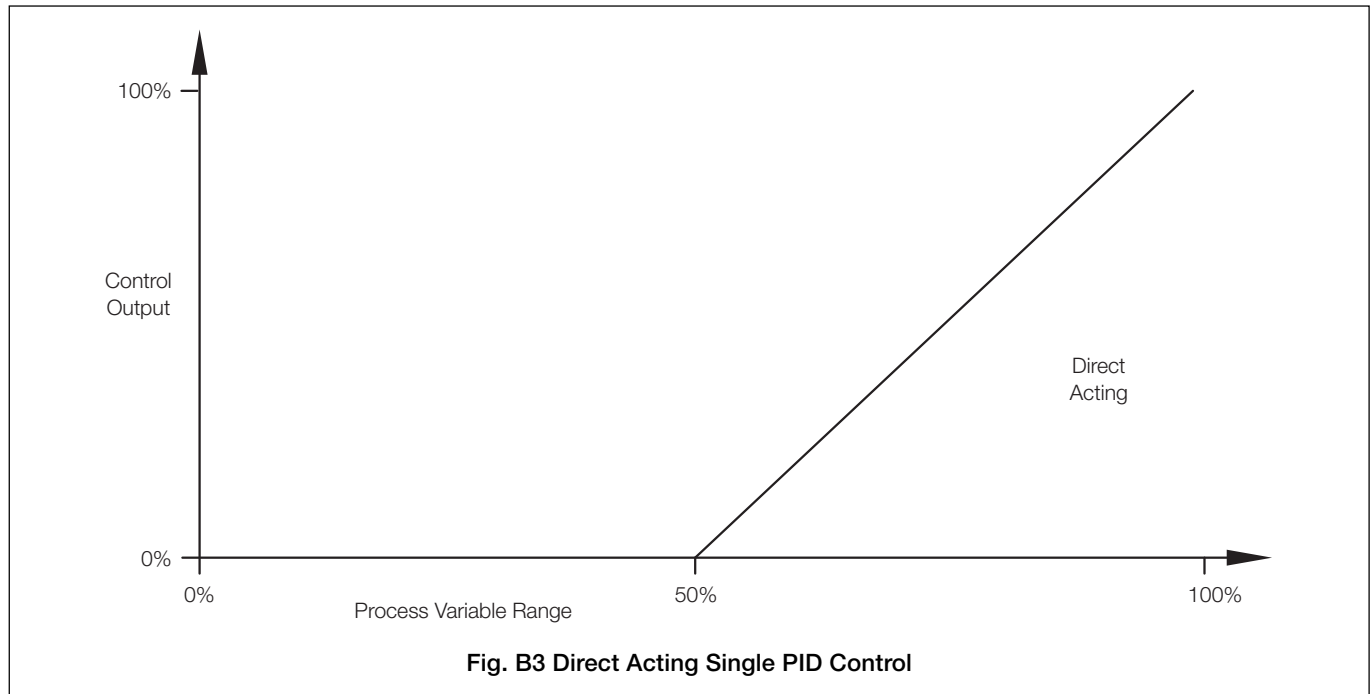

B2 Output Assignment

The output signal is assignable to either relay 1 (Time or Pulse output type) or analog output 1 (Analog output type).

B3 Setting Up Three Term (PID) Control Parameters

To enable a process to be controlled satisfactorily, the following conditions must apply:

- a) The process must be capable of reaching a natural balance with a steady load.
- b) It must be possible to introduce small changes into the system without destroying either the process or the product.

The **Proportional Band** determines the gain of the system. (the gain is the reciprocal of the proportional band setting, e.g. a setting of 20% is equivalent to a gain of 5). If the proportional band is too narrow, the control loop may become unstable and cause the system to oscillate. With proportional band control only, the system normally stabilizes eventually but at a value which is offset from the set point.

The addition of **Integral Action Time** removes the offset but, if set too short, can cause the system to go into oscillation. The introduction of **Derivative Action Time** reduces the time required by the process to stabilize.

B4 Manual Tuning

Before starting up a new process or changing an existing one:

- a) Select the **Config. Control** page and ensure that **Controller** is set to **PID** – see Section 5.7.
- b) Select the **PID Controller** page and set the following:

Proportional Band	– 100%	} – see Section 5.7.1
Integral Time	– 0 (off)	
Derivative Time	– 0 (off)	

Notes.

- If the system goes into oscillation with increasing amplitude (Fig. B4 Mode B), reset the proportional band to 200%. If oscillation continues as in Mode B, increase the proportional band further until the system ceases to oscillate.
- If the system oscillates as in Fig. B4 Mode A, or does not oscillate, refer to step c).

- c) Reduce the **Proportional Band** by 20% increments and observe the response. Continue until the process cycles continuously without reaching a stable condition (i.e. a sustained oscillation with constant amplitude as shown in Mode C). This is the critical point.
- d) Note the cycle time 't' (Fig. B4 Mode C) and the **Proportional Band** (critical value) setting.
- e) Set **Proportional Band** to:
 - 1.6 times the critical value (for P+D or P+I+D control)
 - 2.2 times the critical value (for P+I control)
 - 2.0 times the critical value (for P only control)

- f) Set **Integral Time** to:
 - $\frac{t}{2}$ (for P+I+D control)
 - $\frac{t}{1.2}$ (for P+D control)

- g) Set **Derivative Time** to:
 - $\frac{t}{8}$ (for P+I+D control)
 - $\frac{t}{12}$ (for P+D control)

The analyzer is now ready for fine tuning by small adjustments to the P, I and D terms, after the introduction of a small disturbance of the set point.

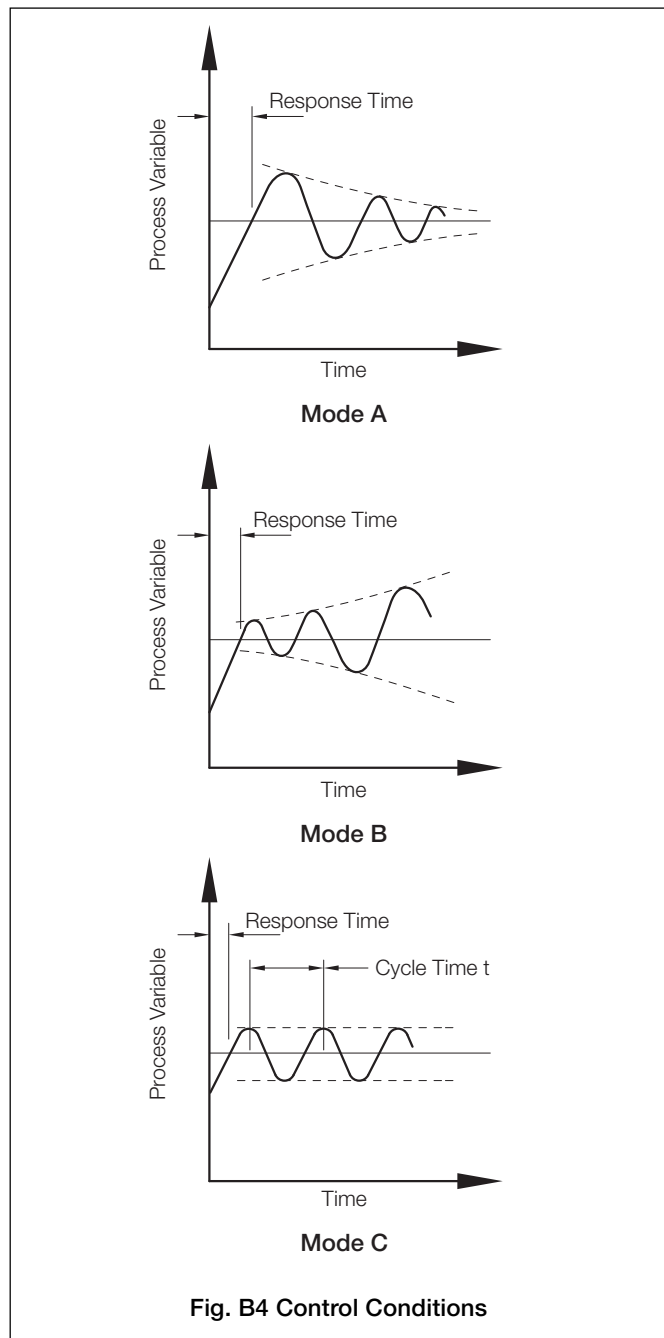

Fig. B4 Control Conditions

NOTES

Products and customer support

Automation Systems

For the following industries:

- Chemical & Pharmaceutical
- Food & Beverage
- Manufacturing
- Metals and Minerals
- Oil, Gas & Petrochemical
- Pulp and Paper

Drives and Motors

- AC and DC Drives, AC and DC Machines, AC Motors to 1kV
- Drive Systems
- Force Measurement
- Servo Drives

Controllers & Recorders

- Single and Multi-loop Controllers
- Circular Chart and Strip Chart Recorders
- Paperless Recorders
- Process Indicators

Flexible Automation

- Industrial Robots and Robot Systems

Flow Measurement

- Electromagnetic Flowmeters
- Mass Flowmeters
- Turbine Flowmeters
- Wedge Flow Elements

Marine Systems & Turbochargers

- Electrical Systems
- Marine Equipment
- Offshore Retrofit and Refurbishment

Process Analytics

- Process Gas Analysis
- Systems Integration

Transmitters

- Pressure
- Temperature
- Level
- Interface Modules

Valves, Actuators and Positioners

- Control Valves
- Actuators
- Positioners

Water, Gas & Industrial Analytics Instrumentation

- pH, Conductivity and Dissolved Oxygen Transmitters and Sensors
- Ammonia, Nitrate, Phosphate, Silica, Sodium, Chloride, Fluoride, Dissolved Oxygen and Hydrazine Analyzers
- Zirconia Oxygen Analyzers, Katharometers, Hydrogen Purity and Purge-gas Monitors, Thermal Conductivity

Customer support

We provide a comprehensive after sales service via a Worldwide Service Organization. Contact one of the following offices for details on your nearest Service and Repair Centre.

UK

ABB Limited
Tel: +44 (0)1453 826661
Fax: +44 (0)1453 829671

USA

ABB Inc.
Tel: +1 215 674 6000
Fax: +1 215 674 7183

Client Warranty

Prior to installation, the equipment referred to in this manual must be stored in a clean, dry environment, in accordance with the Company's published specification. Periodic checks must be made on the equipment's condition. In the event of a failure under warranty, the following documentation must be provided as substantiation:

- A listing evidencing process operation and alarm logs at time of failure.
- Copies of all storage, installation, operating and maintenance records relating to the alleged faulty unit.

Contact us

ABB Limited

Process Automation

Oldends Lane
Stonehouse
Gloucestershire GL10 3TA
UK

Tel: +44 1453 826 661

Fax: +44 1453 829 671

ABB Inc.

Process Automation

125 E. County Line Road
Warminster
PA 18974
USA

Tel: +1 215 674 6000

Fax: +1 215 674 7183

www.abb.com

Note

We reserve the right to make technical changes or modify the contents of this document without prior notice. With regard to purchase orders, the agreed particulars shall prevail. ABB does not accept any responsibility whatsoever for potential errors or possible lack of information in this document.

We reserve all rights in this document and in the subject matter and illustrations contained therein. Any reproduction, disclosure to third parties or utilization of its contents in whole or in parts – is forbidden without prior written consent of ABB.

Copyright© 2011 ABB

All rights reserved