



The Company

We are an established world force in the design and manufacture of instrumentation for industrial process control, flow measurement, gas and liquid analysis and environmental applications.

As a part of ABB, a world leader in process automation technology, we offer customers application expertise, service and support worldwide.

We are committed to teamwork, high quality manufacturing, advanced technology and unrivalled service and support.

The quality, accuracy and performance of the Company's products result from over 100 years experience, combined with a continuous program of innovative design and development to incorporate the latest technology.

The UKAS Calibration Laboratory No. 0255 is just one of the ten flow calibration plants operated by the Company and is indicative of our dedication to quality and accuracy.

EN ISO 9001:2000



Cert. No. Q 05907

EN 29001 (ISO 9001)



Lenno, Italy – Cert. No. 9/90A

Stonehouse, U.K.



Electrical Safety

This equipment complies with the requirements of CEI/IEC 61010-1:2001-2 'Safety Requirements for Electrical Equipment for Measurement, Control and Laboratory Use'. If the equipment is used in a manner NOT specified by the Company, the protection provided by the equipment may be impaired.

Symbols

One or more of the following symbols may appear on the equipment labelling:

| | | | |
|--|---|--|--|
| | Warning – Refer to the manual for instructions | | Direct current supply only |
| | Caution – Risk of electric shock | | Alternating current supply only |
| | Protective earth (ground) terminal | | Both direct and alternating current supply |
| | Earth (ground) terminal | | The equipment is protected through double insulation |

Information in this manual is intended only to assist our customers in the efficient operation of our equipment. Use of this manual for any other purpose is specifically prohibited and its contents are not to be reproduced in full or part without prior approval of the Technical Publications Department.

Health and Safety

To ensure that our products are safe and without risk to health, the following points must be noted:

1. The relevant sections of these instructions must be read carefully before proceeding.
2. Warning labels on containers and packages must be observed.
3. Installation, operation, maintenance and servicing must only be carried out by suitably trained personnel and in accordance with the information given.
4. Normal safety precautions must be taken to avoid the possibility of an accident occurring when operating in conditions of high pressure and/or temperature.
5. Chemicals must be stored away from heat, protected from temperature extremes and powders kept dry. Normal safe handling procedures must be used.
6. When disposing of chemicals ensure that no two chemicals are mixed.

Safety advice concerning the use of the equipment described in this manual or any relevant hazard data sheets (where applicable) may be obtained from the Company address on the back cover, together with servicing and spares information.

Contents

| | | | |
|--|-----------|--|-----------|
| 1 INTRODUCTION | 2 | 7 PROGRAMMING AND ELECTRICAL CALIBRATION .. | 20 |
| 2 MECHANICAL INSTALLATION | 3 | 7.1 Access to Secure Parameters | 20 |
| 2.1 Siting Requirements | 3 | 7.2 Language Page | 20 |
| 2.1.1 Instruments | 3 | 7.3 Set Up Parameters Page | 21 |
| 2.1.2 Dissolved Oxygen Flowcell | 3 | 7.4 Set Up Alarm Page | 22 |
| 2.2 Mounting the Instrument | 3 | 7.5 Set Up Retransmission Page | 24 |
| 2.2.1 Wall-mounted Instrument | 3 | 7.6 Electrical Calibration | 27 |
| 2.2.2 Panel-mounted Instrument | 4 | 7.6.1 Equipment Required | 27 |
| 2.3 Installing the Dissolved Oxygen Flowcell | 5 | 7.6.2 Preparation | 27 |
| 2.3.1 Flowcell Dimensions (Overall) | 5 | 7.7 Factory Settings Page | 28 |
| 2.3.2 Enclosure Dimensions (Optional) | 5 | 8 MAINTENANCE | 31 |
| 2.3.3 Connecting the Sample Lines | 5 | 8.1 Introduction | 31 |
| 3 ELECTRICAL CONNECTIONS | 6 | 8.2 Cleaning/Changing the Sensor | 31 |
| 3.1 Access to Terminals | 6 | 8.2.1 Cleaning | 31 |
| 3.1.1 Wall-mounted Instruments | 6 | 8.2.2 Changing the Sensor | 32 |
| 3.1.2 Panel-mounted Instruments | 6 | 9 SIMPLE FAULT FINDING | 33 |
| 3.2 Connections, General | 7 | 9.1 Diagnostic Messages | 33 |
| 3.2.1 Relay Contact Protection and Interference Suppression | 7 | 9.2 Low Sensor Efficiency/Slow Sensor Cal. or No Response to D.O. Changes | 34 |
| 3.2.2 System Wiring Schematic | 8 | 9.3 Checking the Temperature Input | 34 |
| 3.3 Wall-mounted Instrument Connections | 8 | 9.4 High Sample Readings | 34 |
| 3.4 Panel-mounted Instrument Connections | 9 | 10 Specification | 35 |
| 3.5 Selecting the Mains Voltage | 10 | 11 SPARES | 37 |
| 3.5.1 Wall-mounted Instrument | 10 | 11.1 Strategic Spares | 37 |
| 3.5.2 Panel-mounted Instrument | 10 | Appendix A 9438 080 24 V DC POWER SUPPLY UNIT (OPTIONAL) | 39 |
| 3.6 Flowcell Solenoid Valve Connections | 11 | A.1 Description | 39 |
| 4 SETTING UP | 12 | A.2 PSU Dimensions | 39 |
| 4.1 Fitting the Dissolved Oxygen Sensor | 12 | A.3 Accessing PSU Terminals | 39 |
| 4.2 Connecting the Flowcell | 13 | A.4 PSU Connection | 40 |
| 4.3 Checking Sample Flow | 14 | A.5 Wiring Schematic | 40 |
| 5 CONTROLS AND DISPLAYS | 15 | A.6 Specification | 40 |
| 5.1 Displays | 15 | Appendix B CALIBRATION DIAGNOSTICS | 41 |
| 5.2 Switch Familiarization | 15 | B.1 During Calibration | 41 |
| 6 START UP AND OPERATION | 16 | B.2 Low Sensor Efficiency | 41 |
| 6.1 Instrument Start-up | 17 | Notes | 42 |
| 6.2 Operation – Dissolved Oxygen Measurement Mode | 17 | | |
| 6.2.1 Operation Page | 18 | | |
| 6.2.2 Calibration Page | 19 | | |

1 INTRODUCTION

This manual describes how to install and operate the 9438 Low Level Dissolved Oxygen Monitoring system. Fig. 1.1 shows the main elements of the system. Mechanical and electrical installation details of the optional power supply unit are in Appendix A.

The Dissolved Oxygen (D.O.) transmitters and associated flowcell have been designed for continuous monitoring and control of power station boiler feed water/steam condensate.

Calibration of the sensor can be manually initiated when required, or set to automatic with the programmable frequencies: 1 day, 1 week and 4 weeks.

System status can be assessed remotely using programmable alarm and/or current output diagnostic functions.

The 9438 500 transmitter is a wall-mounted instrument and the 9438 501 model is a panel-mounted, 1/4 DIN-sized instrument. Both instruments have a single programmable D.O. input channel, and a single temperature input channel. The sample temperature is sensed by a Pt1000 resistance thermometer incorporated in the flowcell.

Instrument operation and programming is via four tactile membrane switches located on the front panel. Programs are protected from unauthorized alteration by a five-digit security code.

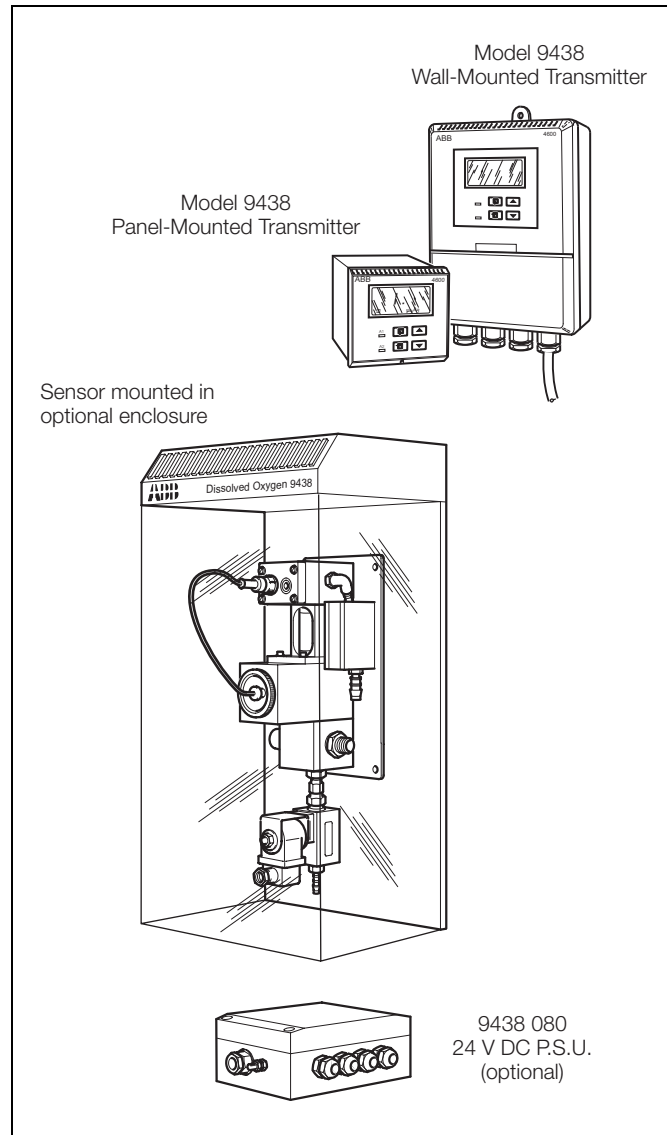

Fig. 1.1 System Elements

2 MECHANICAL INSTALLATION

2.1 Siting Requirements

2.1.1 Instruments

Caution.

- Mount instruments in a location free from excessive vibration.
- Mount away from harmful vapors and/or dripping fluids.

Note. It is preferable to mount the transmitter at eye level thus allowing an unrestricted view of the front panel displays and controls.

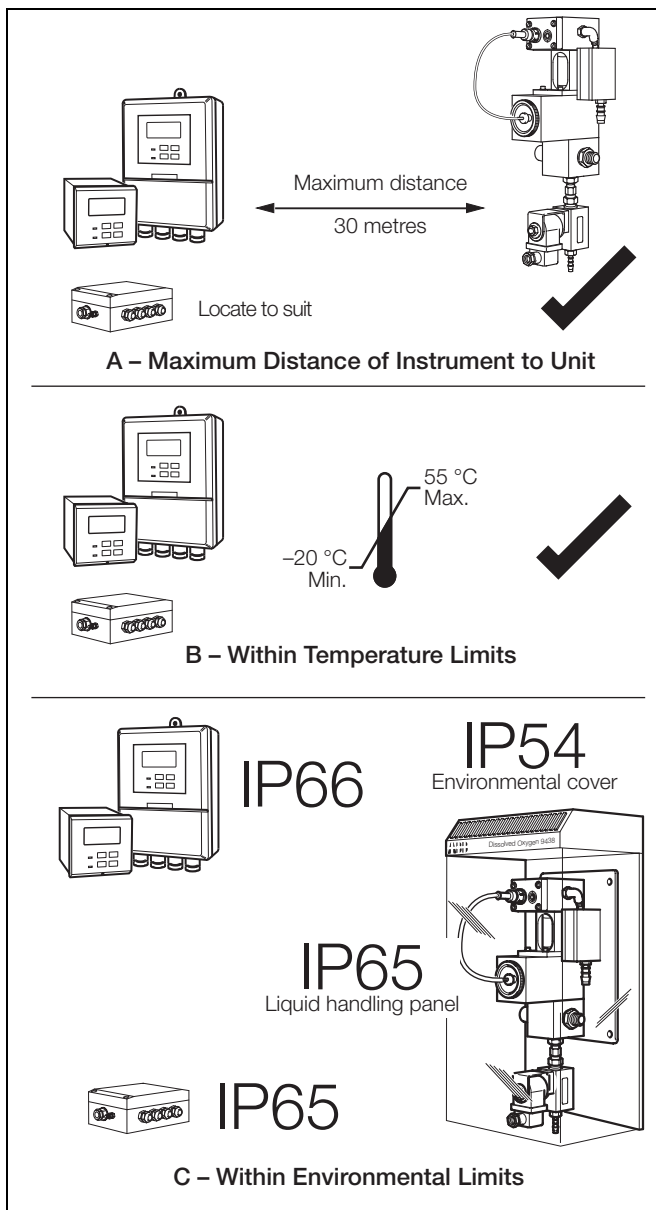

Fig. 2.1 Siting Requirements – Instrument/Sensor

2.1.2 Dissolved Oxygen Flowcell

Allow sufficient clearance (200 mm all around) for easy removal of the flowcell assembly for maintenance when not installed in the optional enclosure – see section 2.3.1, page 5 for overall dimensions of units.

Note. To eliminate the risk of bubbles accumulating at the sensor, and hence giving erroneous readings, the flowcell assembly must be mounted vertically.

2.2 Mounting the Instrument

2.2.1 Wall-mounted Instrument

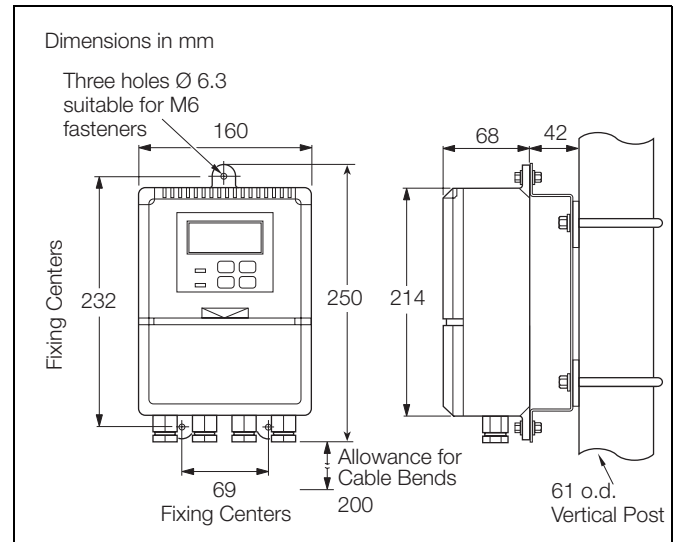

Fig. 2.2 Overall Dimensions

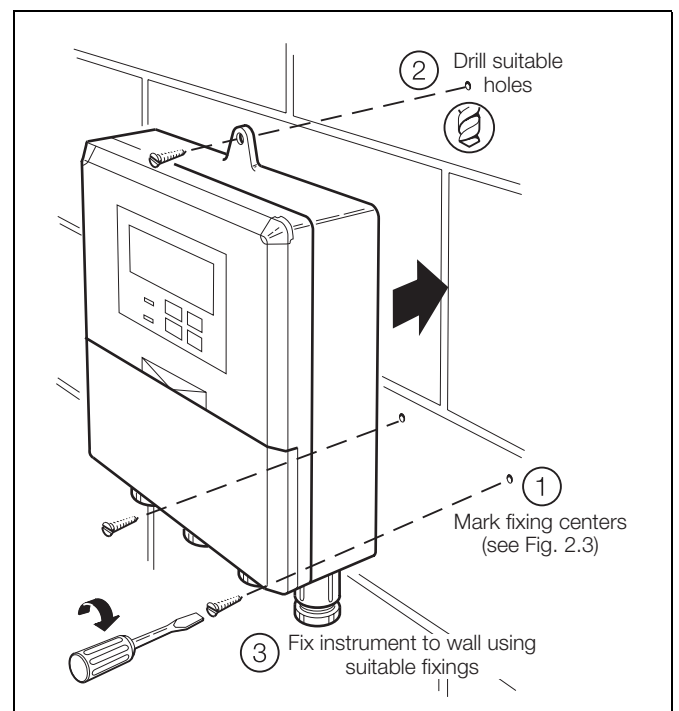

Fig. 2.3 Wall Mounting

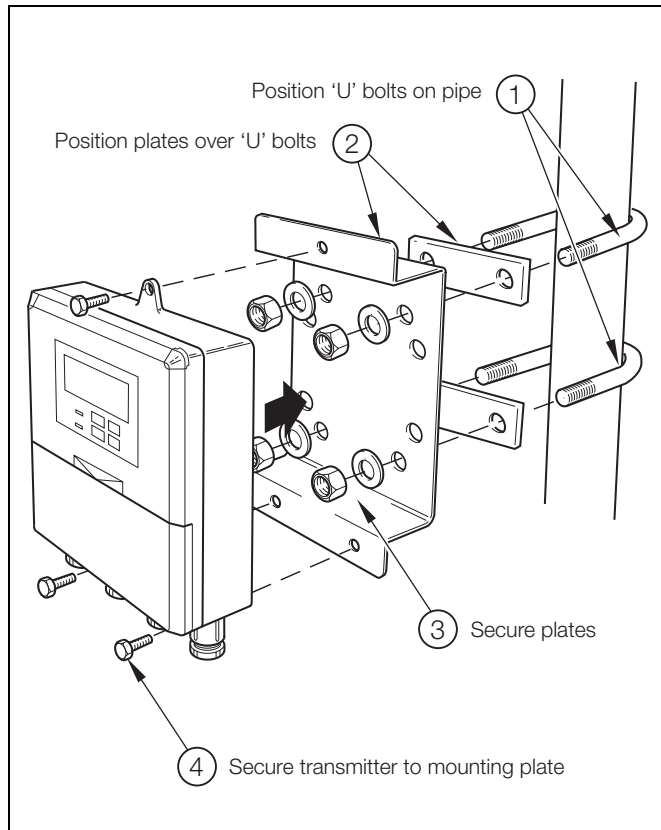

Fig. 2.4 Pipe Mounting

2.2.2 Panel-mounted Instrument

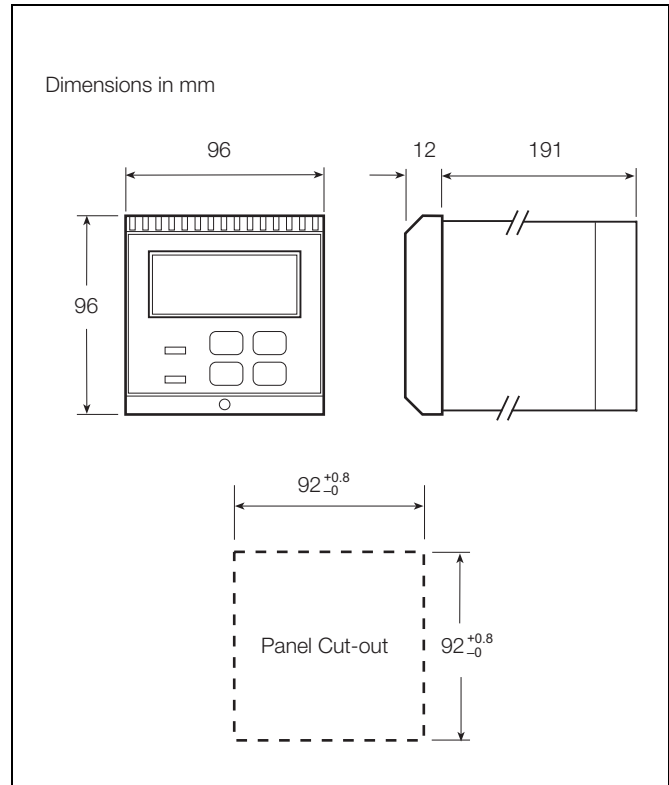

Fig. 2.5 Overall Dimensions

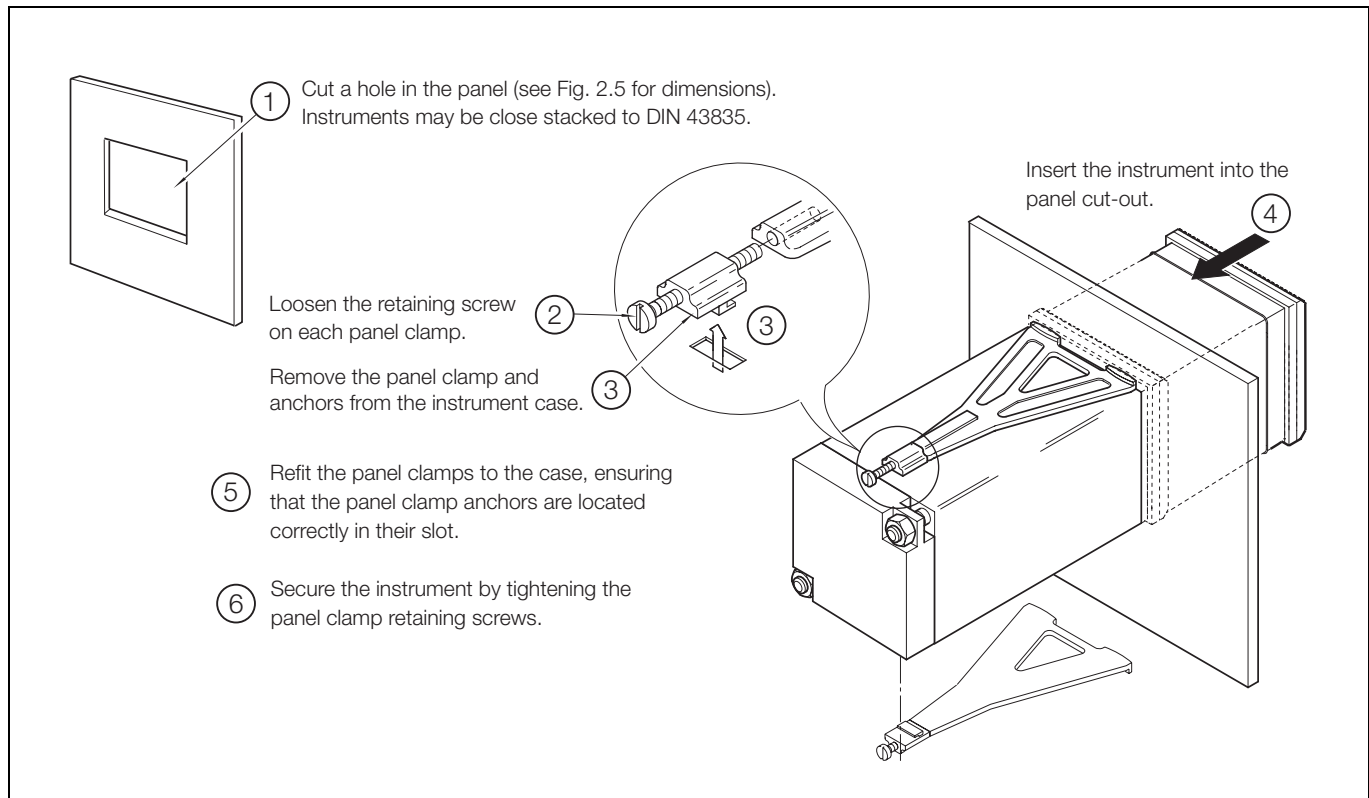

Fig. 2.6 Panel Mounting

2.3 Installing the Dissolved Oxygen Flowcell

2.3.1 Flowcell Dimensions (Overall)

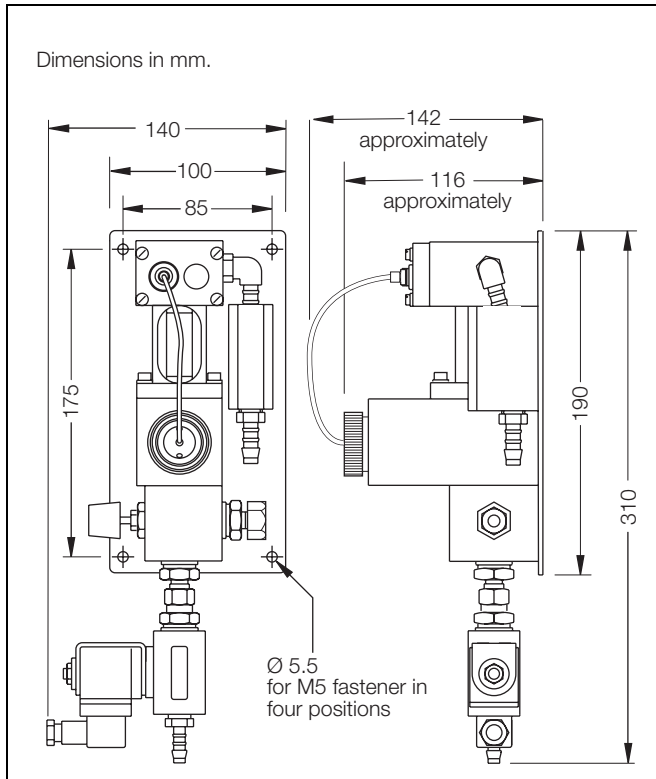

Fig. 2.7 Flowcell Dimensions

2.3.2 Enclosure Dimensions (Optional)

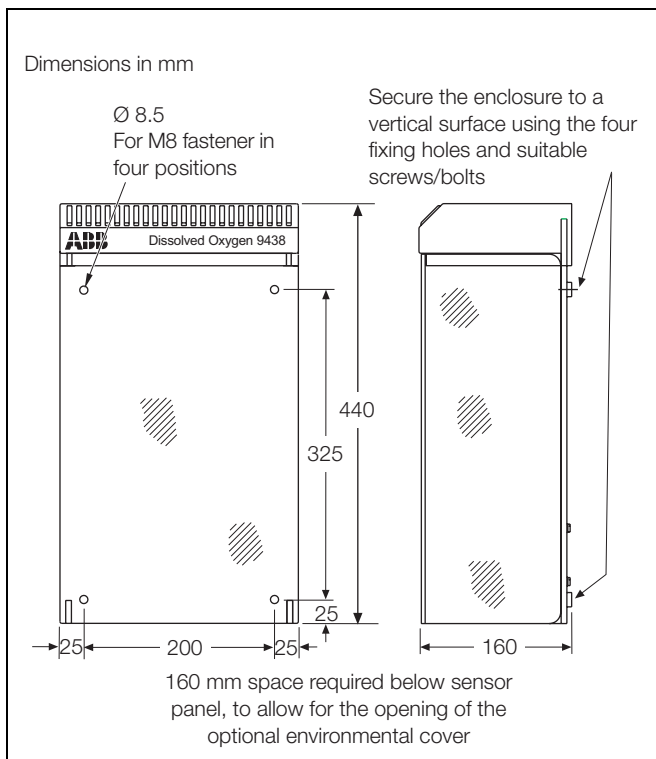

Fig. 2.8 Enclosure Dimensions

2.3.3 Connecting the Sample Lines

Mount the flowcell vertically (with or without the enclosure) as shown in Fig. 2.7 and Fig. 2.8. Connect the sample inlet and outlet tubes as shown in Fig. 2.9.

Note.

- The sample flowrate must be between 100 and 400 ml min⁻¹.
- The Company recommends that stainless steel tubing is used for sample inlet lines.
- All sample drains should be kept as short as possible and be vertical to allow the sample to drain freely.

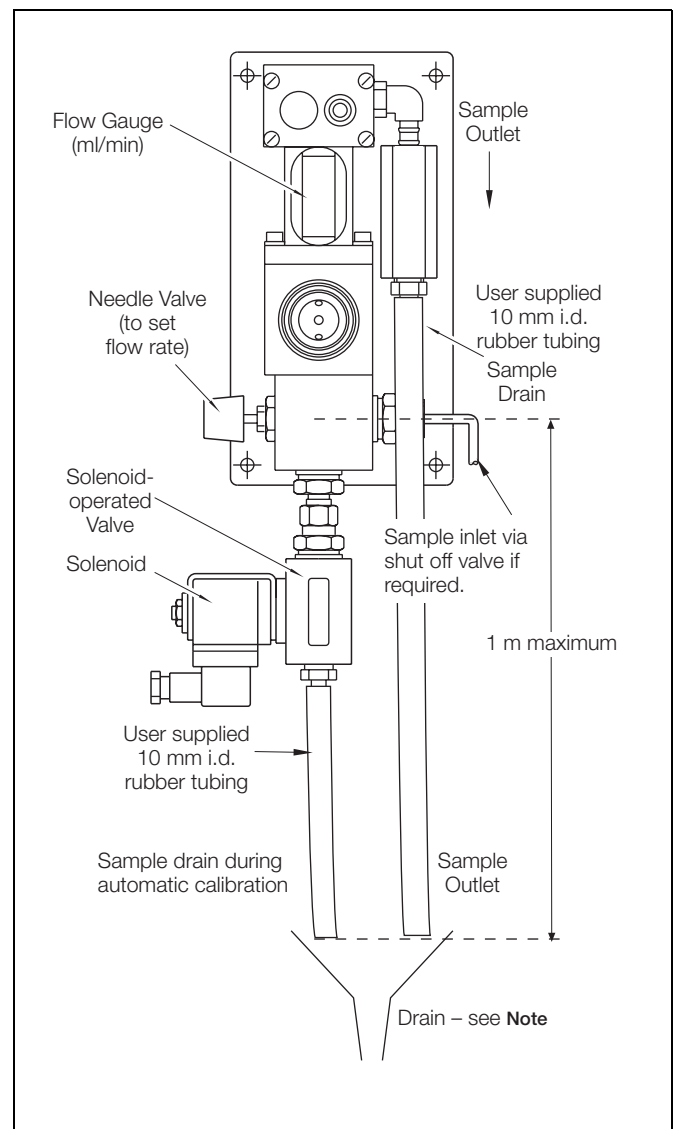

Fig. 2.9 Connecting the Sample Lines

Note. Drain tubes must be straight and vertical to allow the sample to flow freely.

3 ELECTRICAL CONNECTIONS

Warning.

- Before making any connections, ensure that the power supply, any high voltage-operated control circuits and high common mode voltage are switched off.
- Although certain instruments are fitted with internal fuse protection, a suitably rated external protection device, e.g. fuse or miniature circuit breaker (m.c.b.), must also be fitted by the installer.

3.1 Access to Terminals

3.1.1 Wall-mounted Instruments

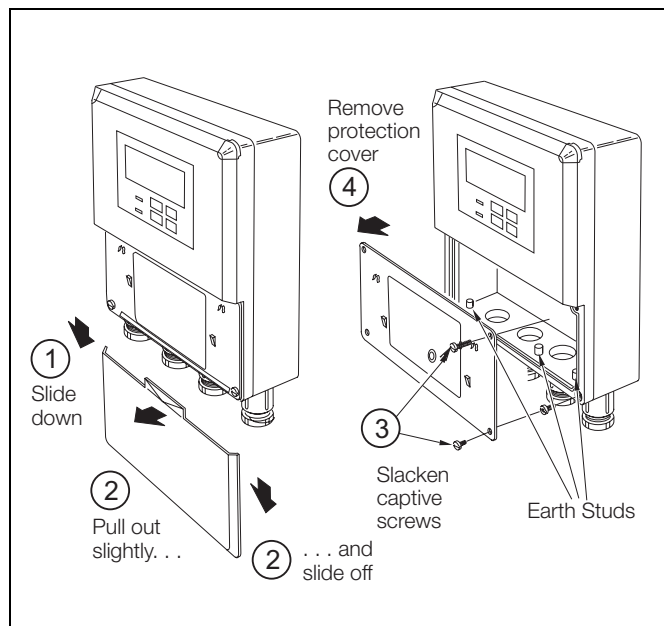

Fig. 3.1 Access to Terminals – Wall-mounted Instrument

3.1.2 Panel-mounted Instruments

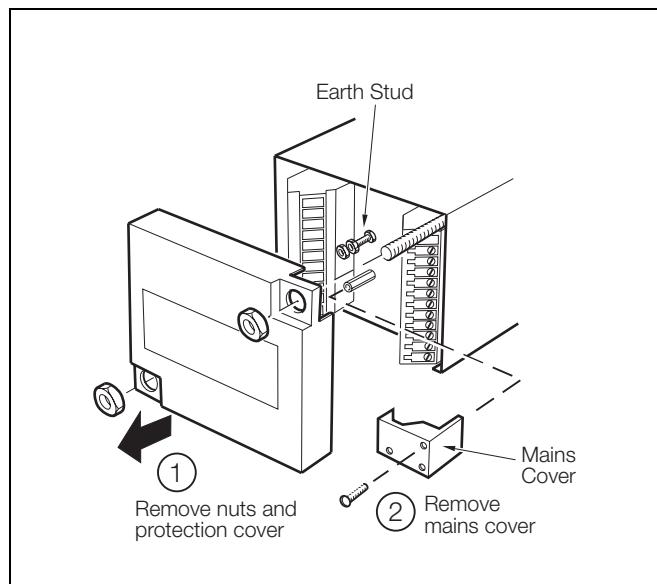

Fig. 3.2 Access to Terminals – Panel-mounted Instrument (Rear View)

3.2 Connections, General

Note.

- **Earthing (grounding)** – stud terminals are fitted to the transmitter case for bus-bar earth (ground) connection – see Fig. 3.1 or Fig. 3.2.
- **Cable lengths** – the cable length between the flowcell and the electronics unit is provided as ordered, and suitably terminated at both ends.
- **Cable routing** – always route the signal cable and mains-carrying/relay cables separately, ideally in earthed metal conduit. Ensure that the cables enter the transmitter through the glands nearest the appropriate screw terminals and are short and direct. Do not tuck excess cable into the terminal compartment.
- **Cable glands & conduit fittings** – ensure a moisture-tight fit when using cable glands, conduit fittings and blanking plugs/bungs (M20 holes). The M16 glands ready-fitted to wall-mounted instruments accept cable of between 4 and 7 mm diameter.
- **Alarm Relay** – the relay contacts are voltage-free and must be appropriately connected in series with the power supply and the alarm/control device which they are to actuate. Ensure that the contact rating is not exceeded. Refer also to Section 3.2.1 for relay contact protection details when the relays are to be used for switching loads.
- **Retransmission output** – do not exceed the maximum load specification for the selected current retransmission range – see section 7, page 20.

Since the retransmission output is isolated the –ve terminal must be connected to earth (ground) if connecting to the isolated input of another device.

3.2.1 Relay Contact Protection and Interference Suppression

If the relays are used to switch loads on and off, the relay contacts can become eroded due to arcing. Arcing also generates radio frequency interference (RFI) which can result in instrument malfunction and incorrect readings. To minimize the effects of RFI, arc suppression components are required; resistor/capacitor networks for AC applications or diodes for DC applications. These components can be connected either across the load or directly across the relay contacts. On 4600 Series instruments the RFI components must be fitted to the relay terminal block along with the supply and load wires – see Fig. 3.3.

For **AC applications** the value of the resistor/capacitor network depends on the load current and inductance that is switched. Initially, fit a 100R/0.022 μF RC suppressor unit (part no. B9303) as shown in Fig. 3.3A. If the instrument malfunctions (incorrect readings) or resets (display shows 88888) the value of the RC network is too low for suppression – an alternative value must be used. If the correct value cannot be obtained, contact the manufacturer of the switched device for details on the RC unit required.

For **DC applications** fit a diode as shown in Fig. 3.3B. For general applications use an IN5406 type (600 V peak inverse voltage at 3 A – part no. B7363).

Note. For reliable switching the minimum voltage must be greater than 12 V and the minimum current greater than 100 mA.

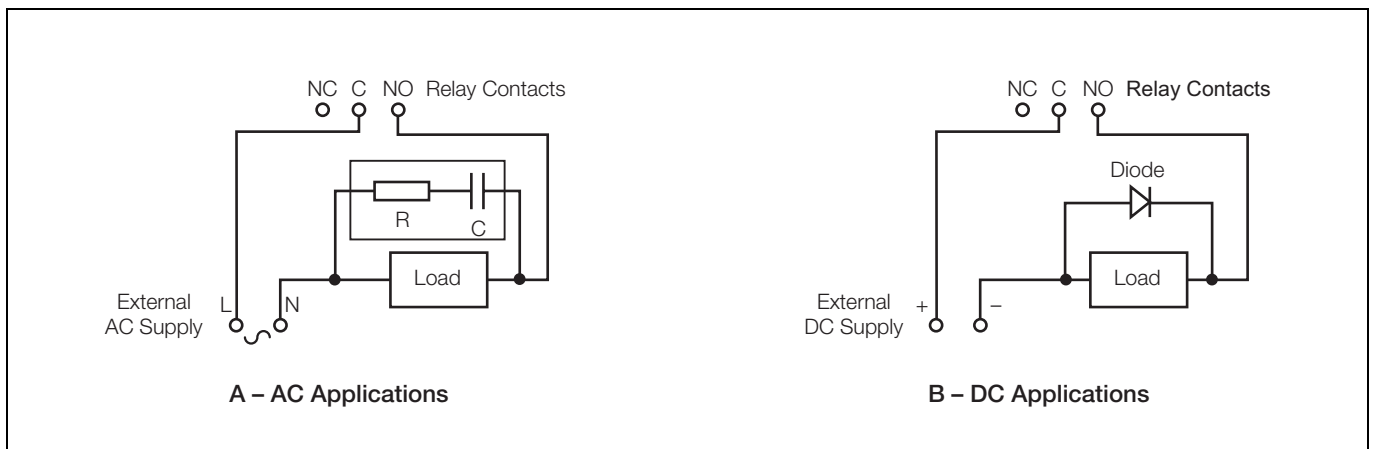

Fig. 3.3 Relay Contact Protection

3.2.2 System Wiring Schematic

The wiring of a single solenoid/sensor system from a user-supplied 24 V DC supply is shown in Fig. 3.4.

If the 9438 080 power supply unit is employed, refer to Appendix A for wiring details.

3.3 Wall-mounted Instrument Connections

Note. Refer to Fig. 3.1 for access to terminals.

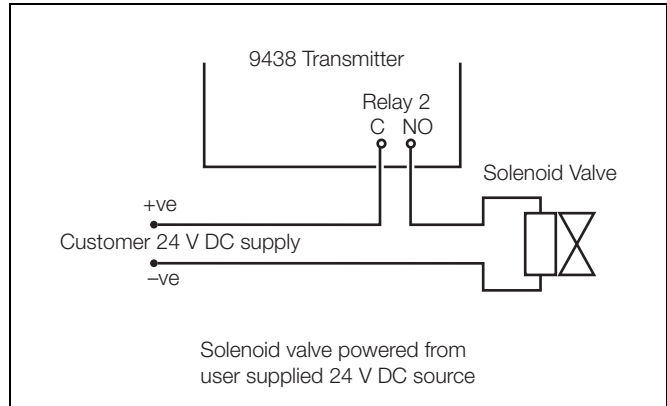

Fig. 3.4 Wiring Schematic
(see Appendix A for wiring using optional PSU)

Caution. Slacken terminal screws fully before making connections.

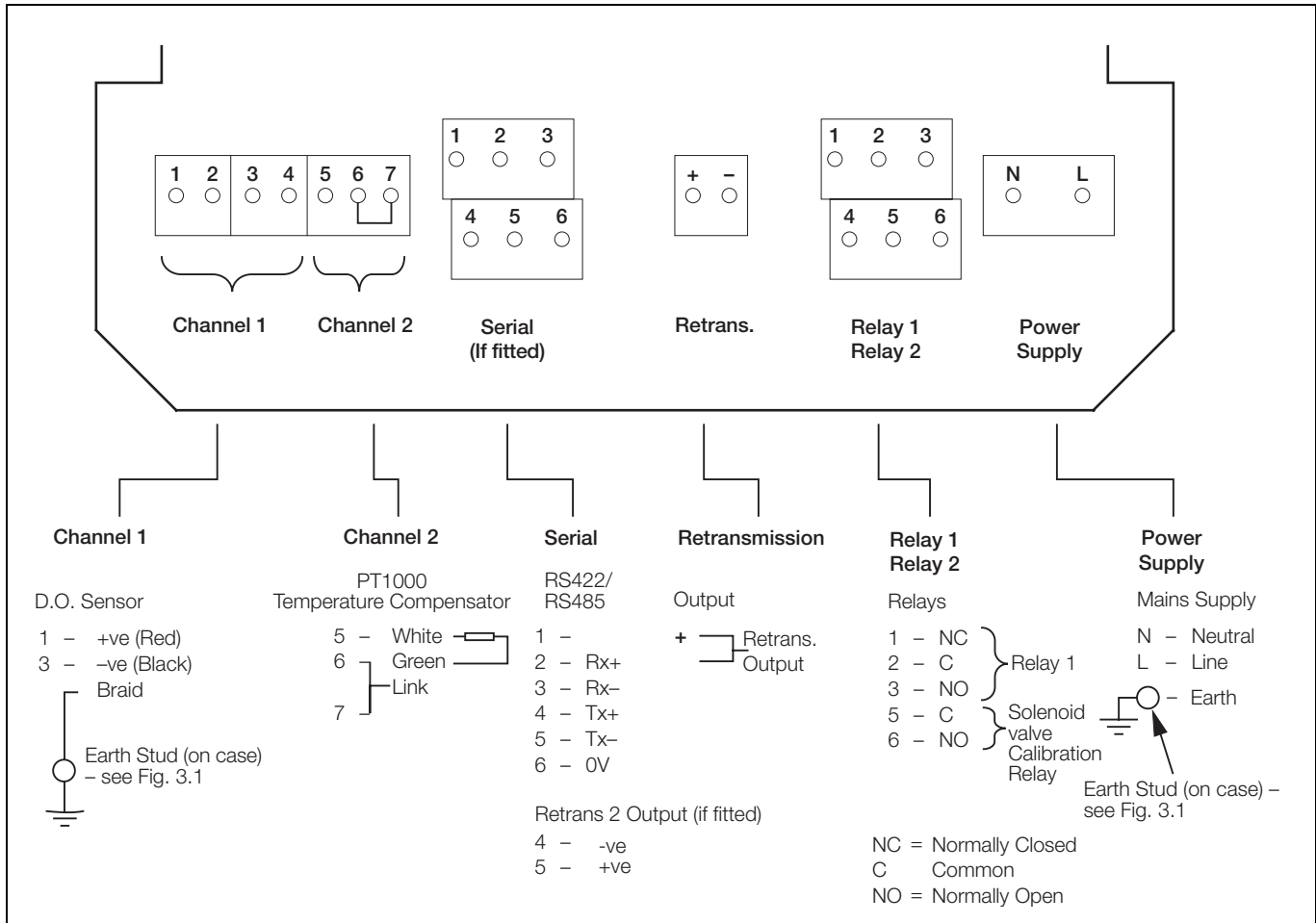

Fig. 3.5 Wall-mounted Instrument Connections

Warning. The power supply earth (ground) must be connected to ensure safety to personnel, reduction of the effects of RFI and correct operation of the power supply interference filter.

3.4 Panel-mounted Instrument Connections

Note. Refer to Fig. 3.2 for Access to Terminals.

Caution. Slacken terminal screws fully before making connections.

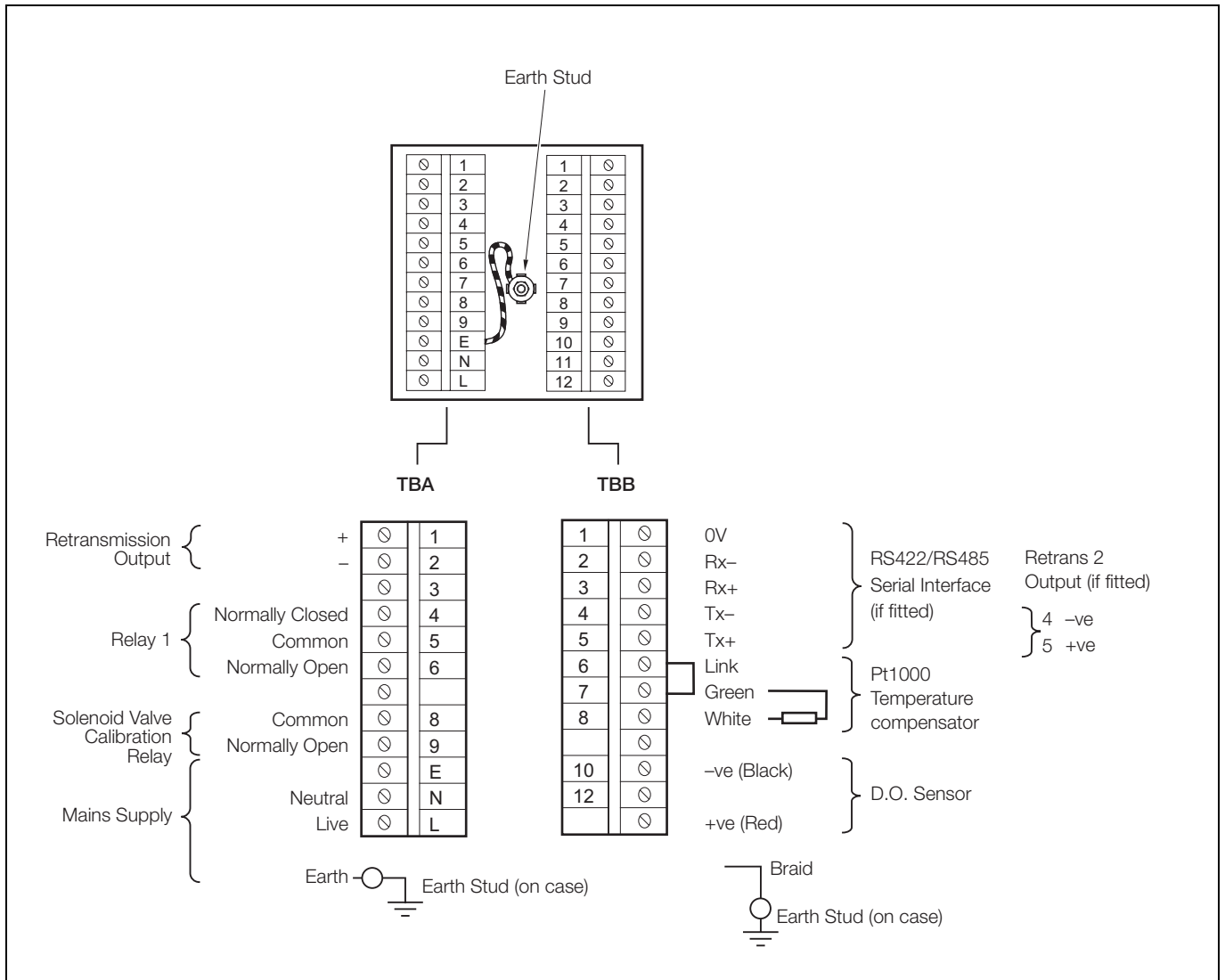

Fig. 3.6 Panel-mounted Instrument Connections

Warning. The power supply earth (ground) must be connected to ensure safety to personnel, reduction of the effects of RFI and correct operation of the power supply interference filter.

3.5 Selecting the Mains Voltage

3.5.1 Wall-mounted Instrument

Note. Some versions are fitted with a switch in place of links. The applied voltage should be as indicated on the switch, when positioned.

Note. Use a small, flatblade screwdriver to remove the screw caps from the case.

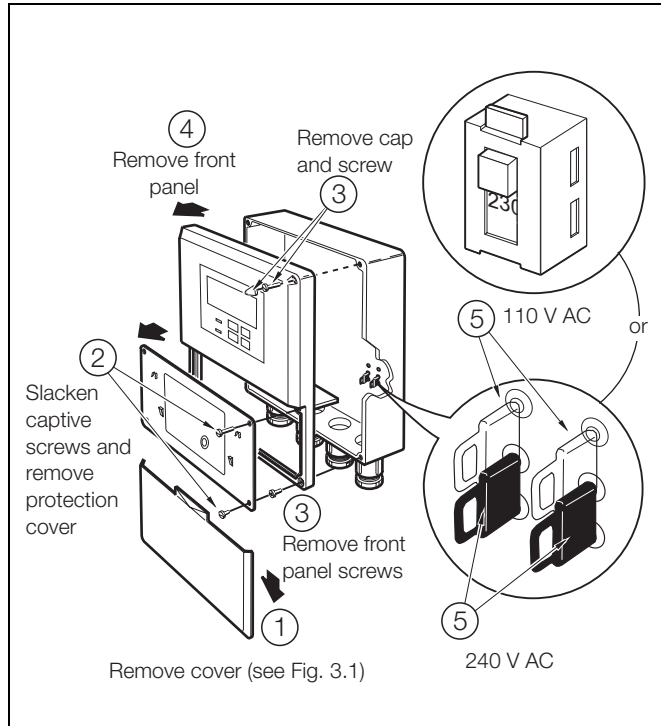

Fig. 3.7 Selecting the Mains Voltage – Wall-mounted Instrument

3.5.2 Panel-mounted Instrument

Note. Some versions are fitted with a switch in place of links. The applied voltage should be as indicated on the switch, when positioned.

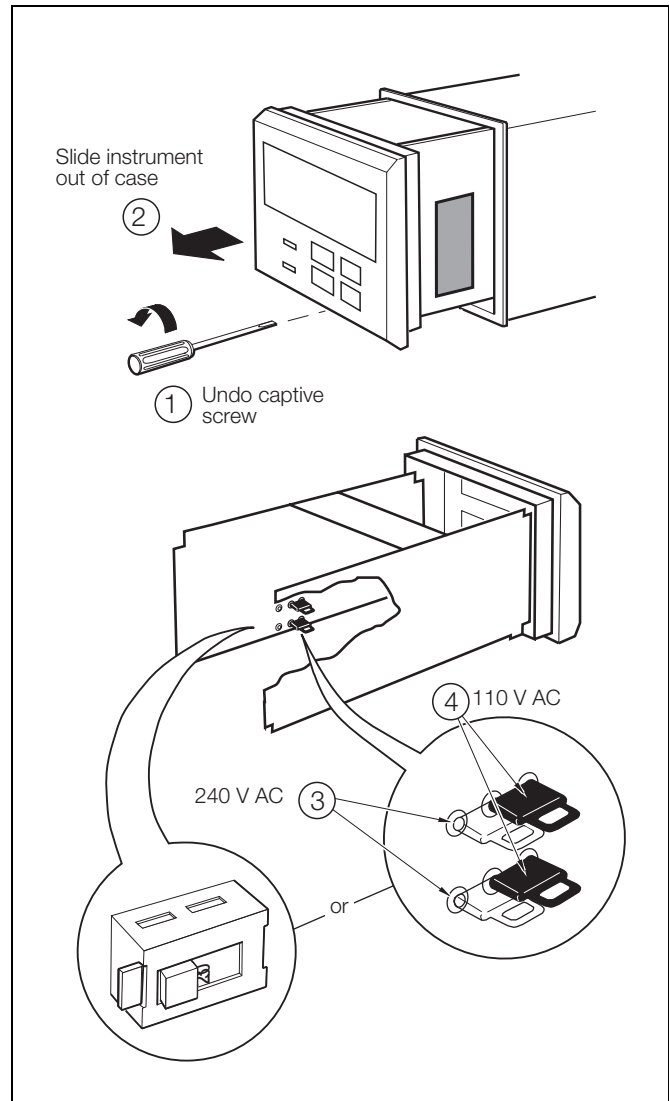

Fig. 3.8 Selecting the Mains Voltage – Panel-mounted Instrument

3.6 Flowcell Solenoid Valve Connections

Note.

- Use 2 core cable with 9438 080 PSU (ABB part number 0233 731).
- Use 3 core cable with customer supplied 24 V DC supply.

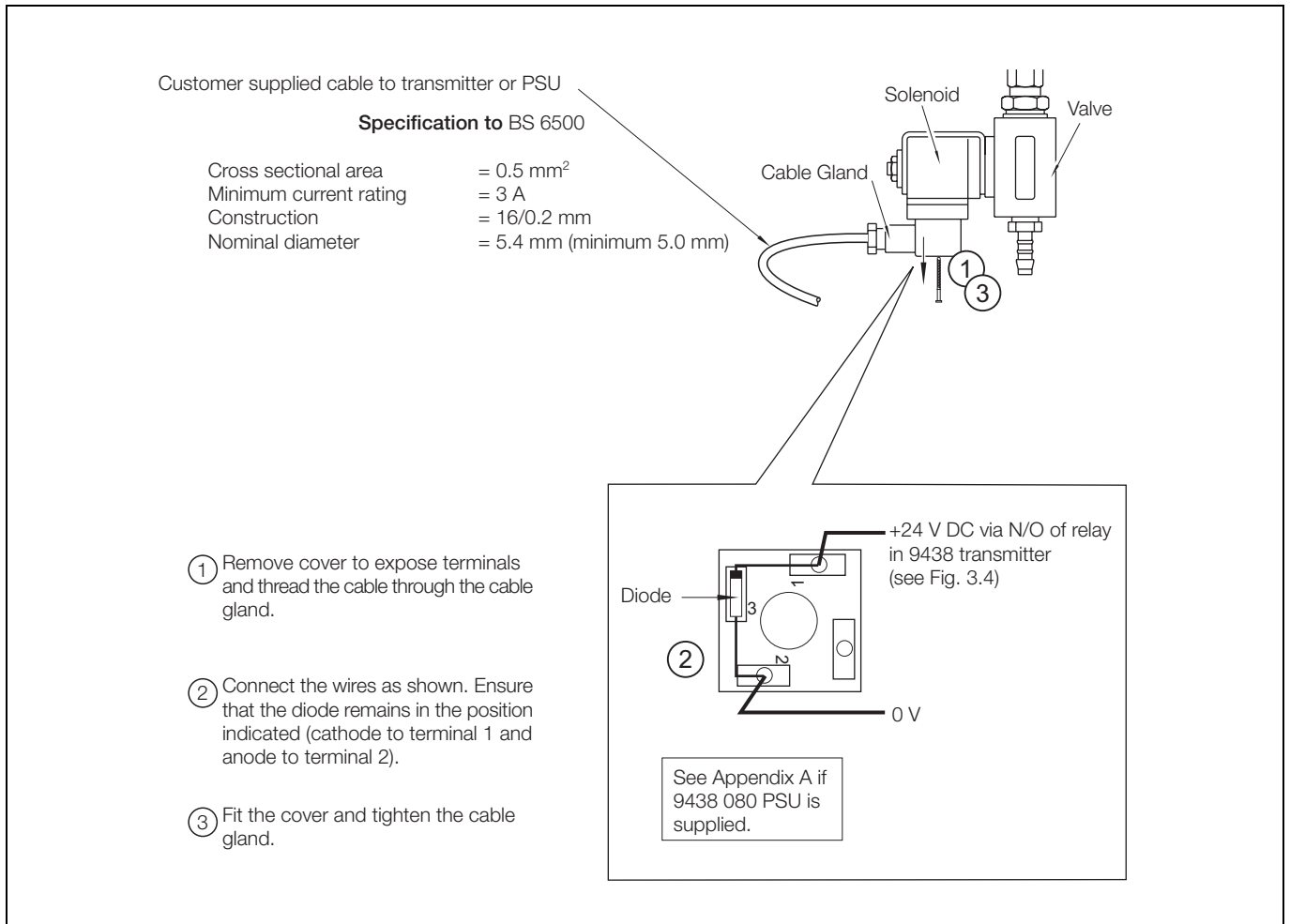

Fig. 3.9 Solenoid Connections

4 SETTING UP

4.1 Fitting the Dissolved Oxygen Sensor

Caution.

- Only install the oxygen sensor immediately prior to use, otherwise leave it stored in its protective container. The sensor has a limited shelf life and should NOT be stored longer than about 6 months. Store under cool conditions.
- Take special care to line up the two pins in the oxygen sensor with their respective sockets before making the connection and tightening.
- Take care not to damage the delicate membrane on the end of the oxygen sensor.
- Ensure that the mating surfaces (carrying the electrical connection) of the oxygen sensor and connector body are clean and completely dry.

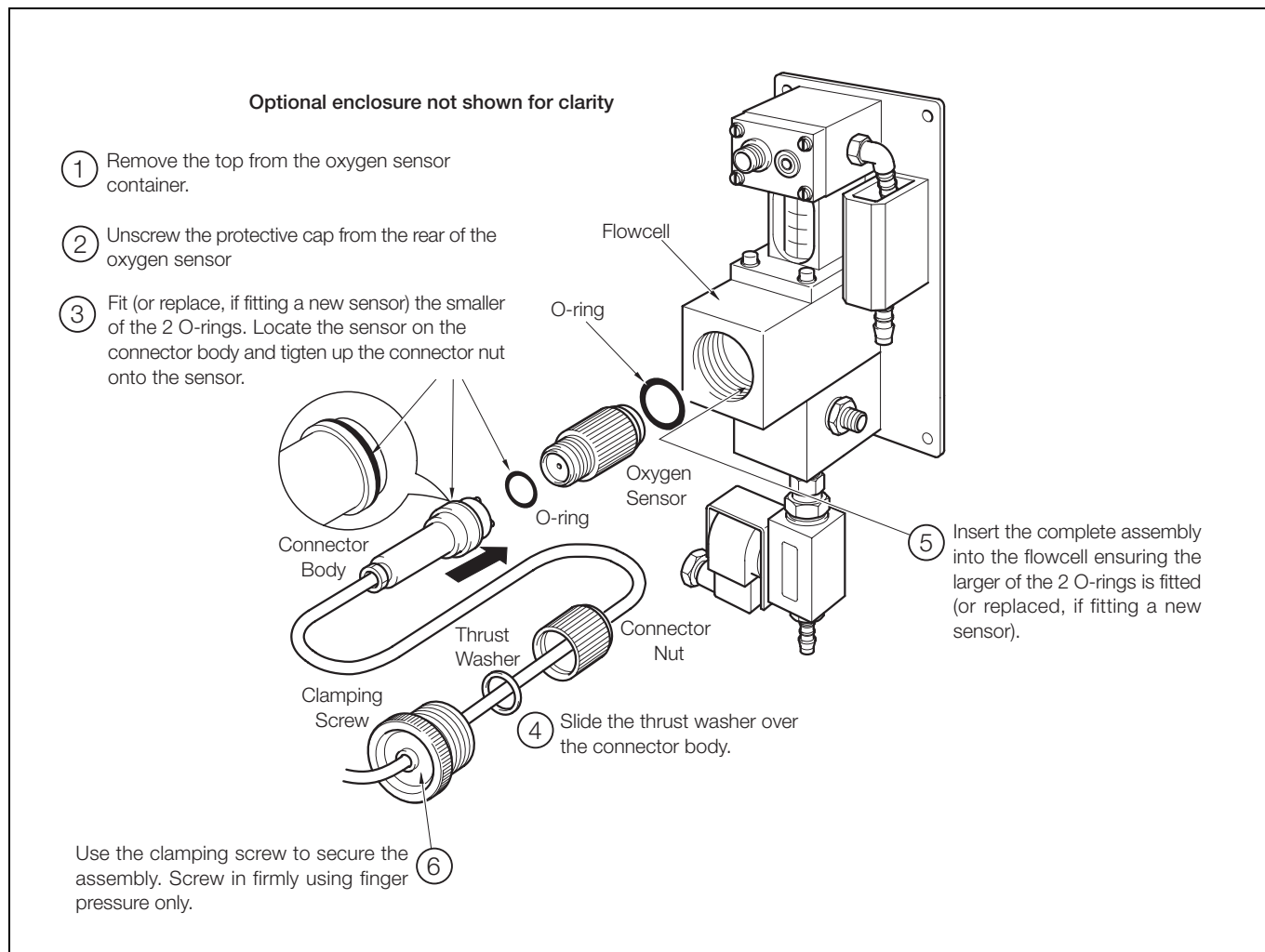

Fig. 4.1 Fitting the Dissolved Oxygen Sensor

Caution. Do not overtighten the clamping screw.

4.2 Connecting the Flowcell

Note.

- The plug is a latching type to prevent its accidental removal. To remove, hold the plug at its widest point and pull out.
- The plug is protected against spillage and corrosion by a sleeve which slides over it.

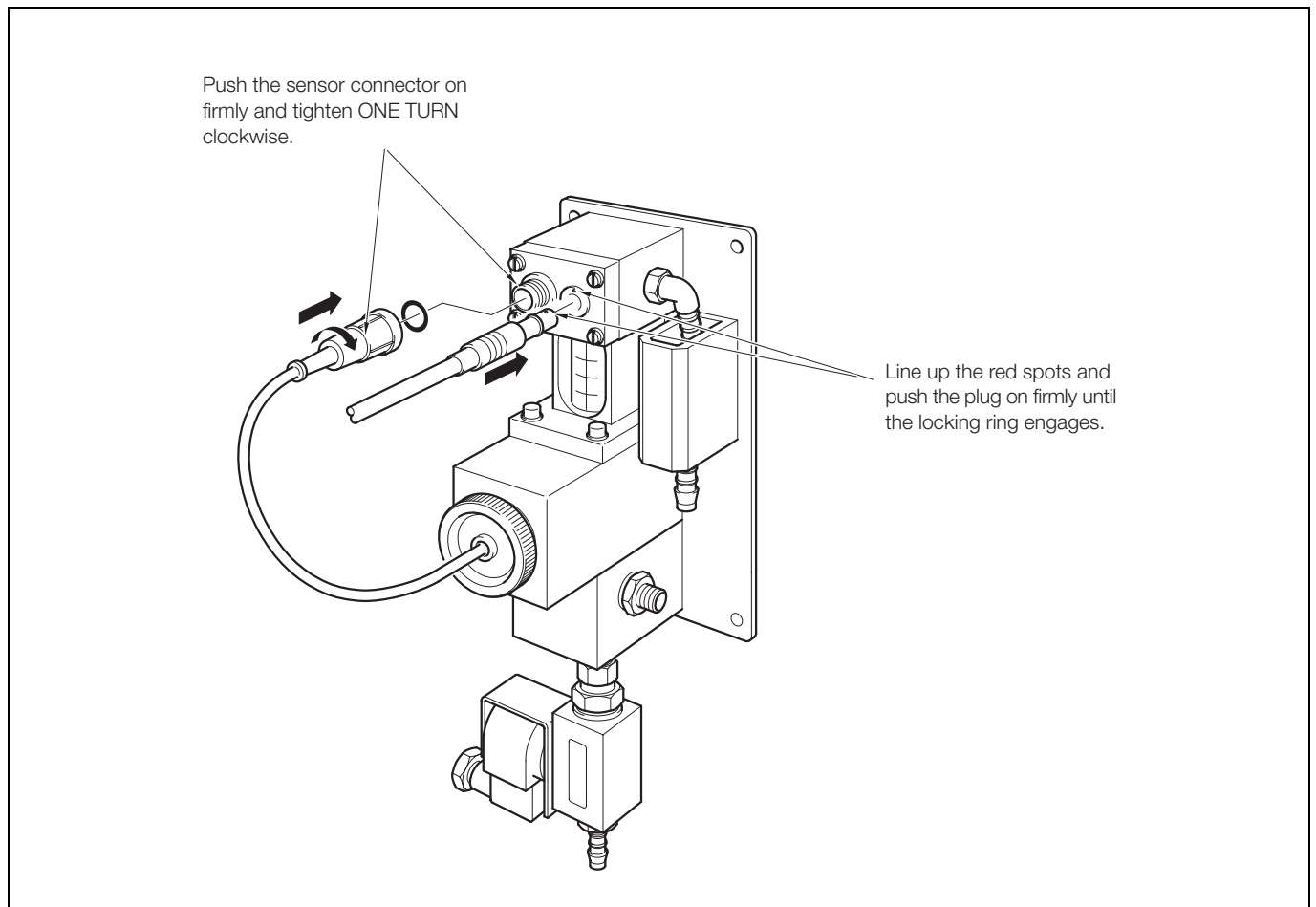

Fig. 4.2 Electrical Connections at the Flowcell

4.3 Checking Sample Flow

Check that the sample flows correctly in both normal operation and during a calibration or thermal overload. To simulate a calibration manually, open the valve – see section 6.2.1, page 18 **Operating Page**. Carefully remove the dissolved oxygen sensor and check that the flowcell is empty. If sample still flows, check that the installation complies with see section 2.3.3, page 5.

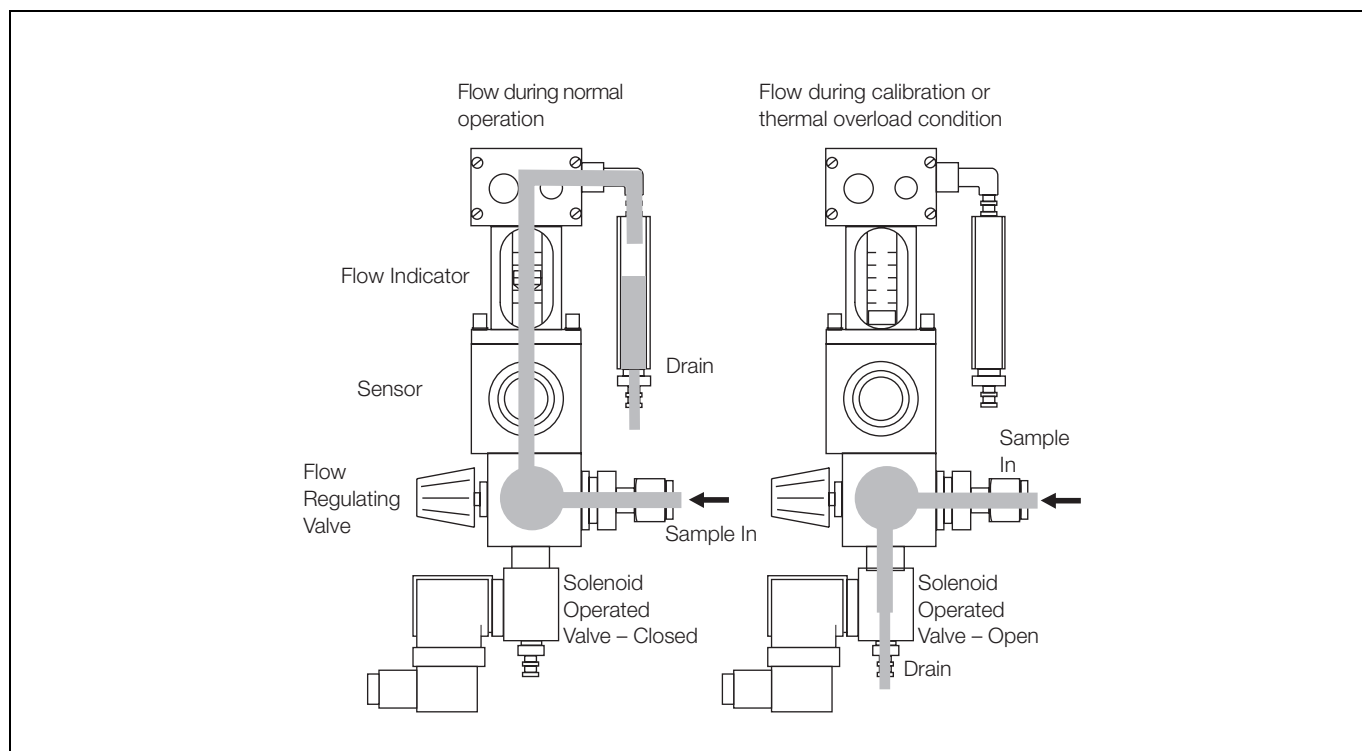

Fig. 4.3 Sample Flow Schematic

5 CONTROLS AND DISPLAYS

5.1 Displays

The display comprises a 5-digit, 7-segment digital upper display line and a 16-character dot-matrix lower display line. The upper display line shows numerical values of dissolved oxygen concentration, temperature, alarm set points or programmable parameters. The lower display line shows the associated units or programming information.

5.2 Switch Familiarization

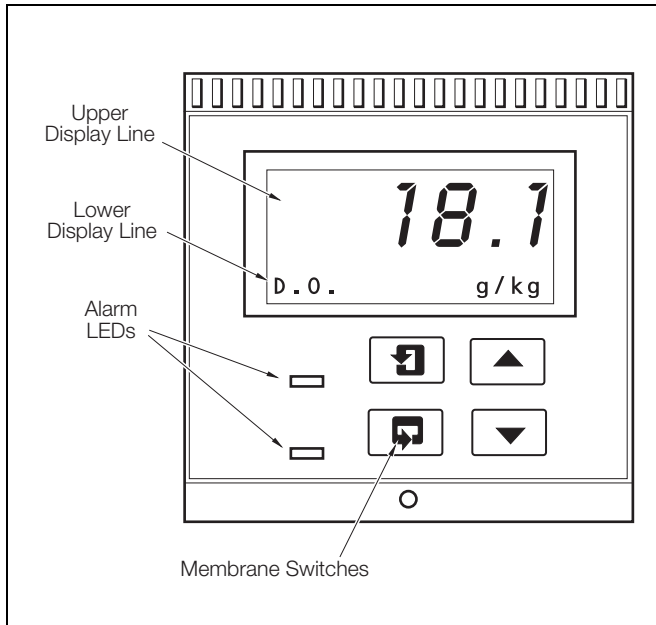

Fig. 5.1 Location of Controls and Displays

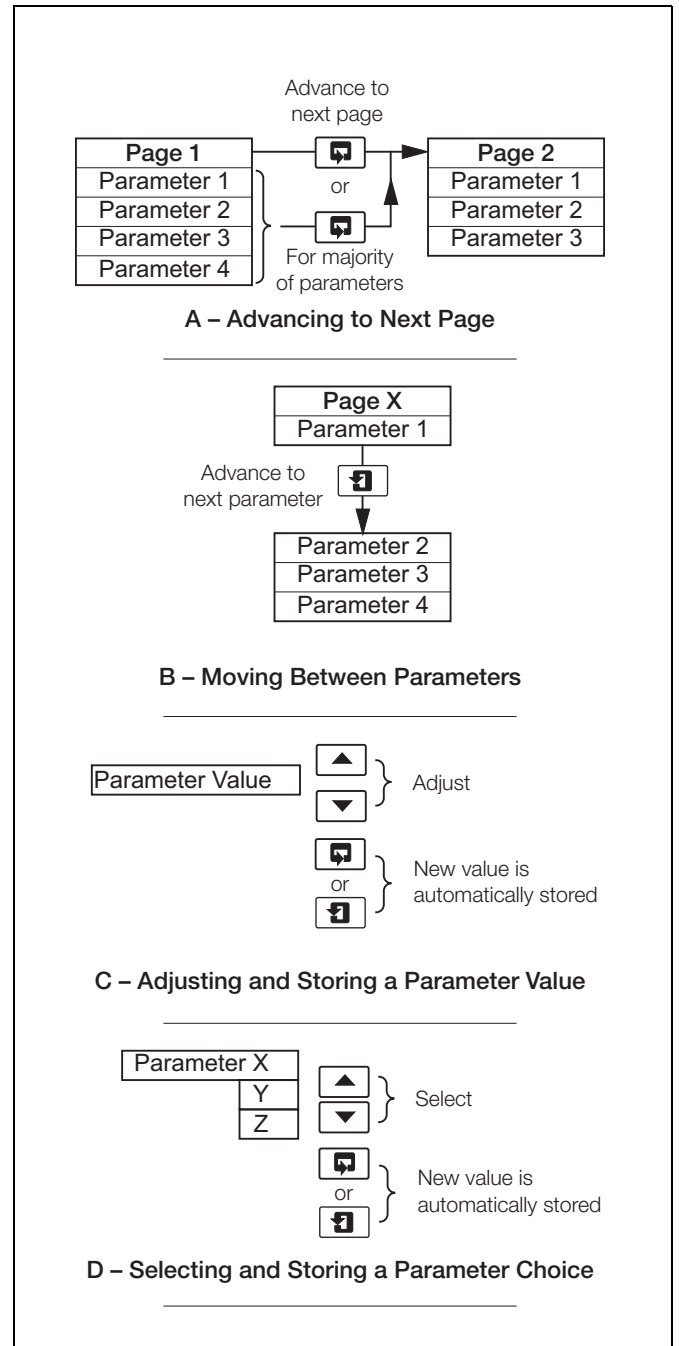

Fig. 5.2 Membrane Switch Functions

6 START UP AND OPERATION

Note. The values shown on the pages in this illustration are the factory default values.

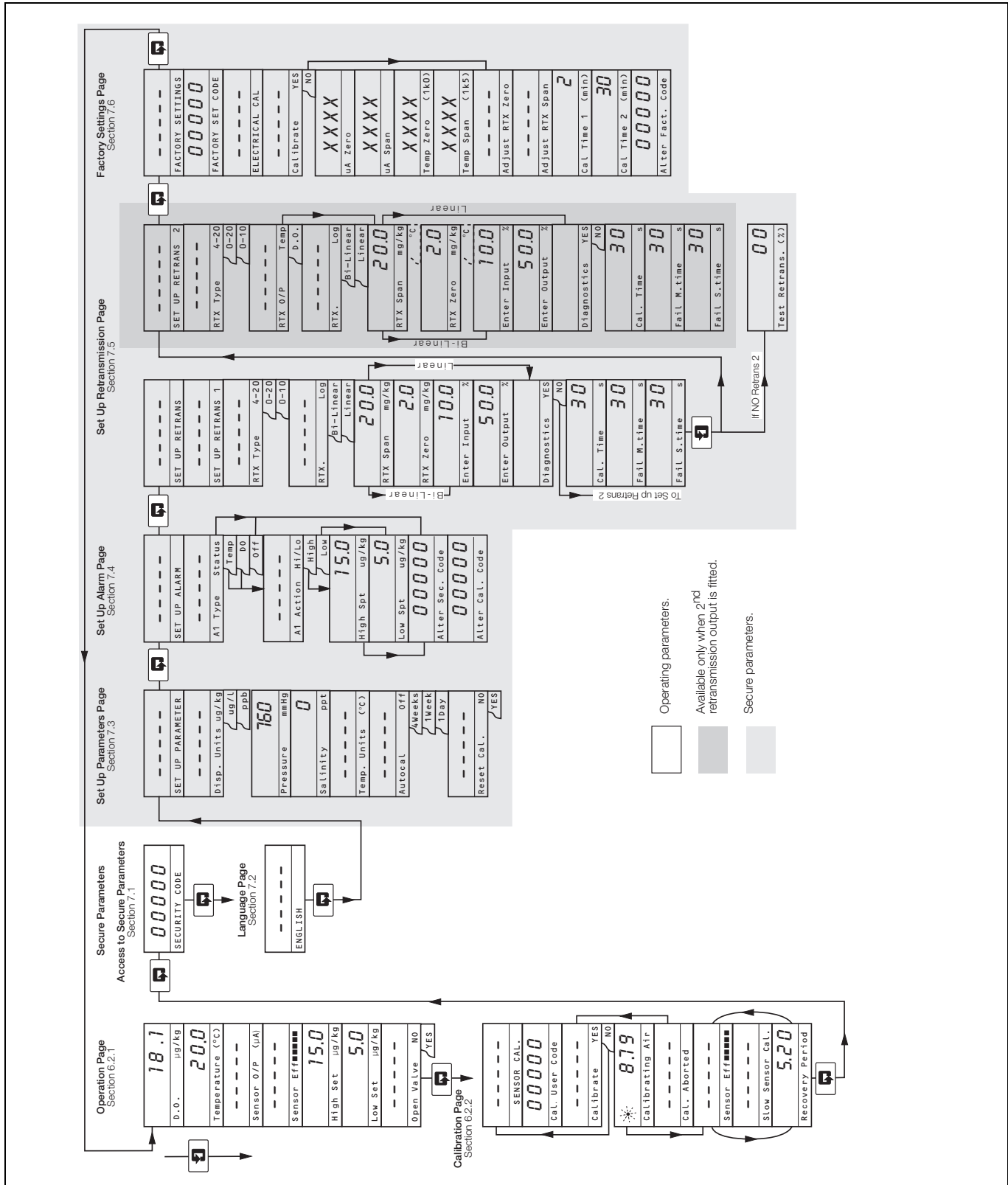

Fig. 6.1 Overall Programming Chart

6.1 Instrument Start-up

Ensure all electrical connections have been made and switch on the power supply. If the instrument is being commissioned for the first time, calibration and programming of parameters is required.

The overall operating and programming chart is shown in Fig. 6.1.

6.2 Operation – Dissolved Oxygen Measurement Mode

Operation in the Dissolved Oxygen measurement mode comprises an **Operating Page** and a **Calibration Page**. The **Operating Page** is a general use page in which parameters are viewed only and cannot be altered. To alter or program a parameter, refer to the programming pages in Section 7. The **Calibration Page** allows a calibration to be carried out. A 5-digit calibration code is used to prevent unauthorized access to the sensor calibration page. The value is preset at 00000 to allow access during commissioning, but should be altered to a unique value, known only to authorized operators, in the **Set Up Alarm page** – see section 7.2, page 20.

6.2.1 Operation Page

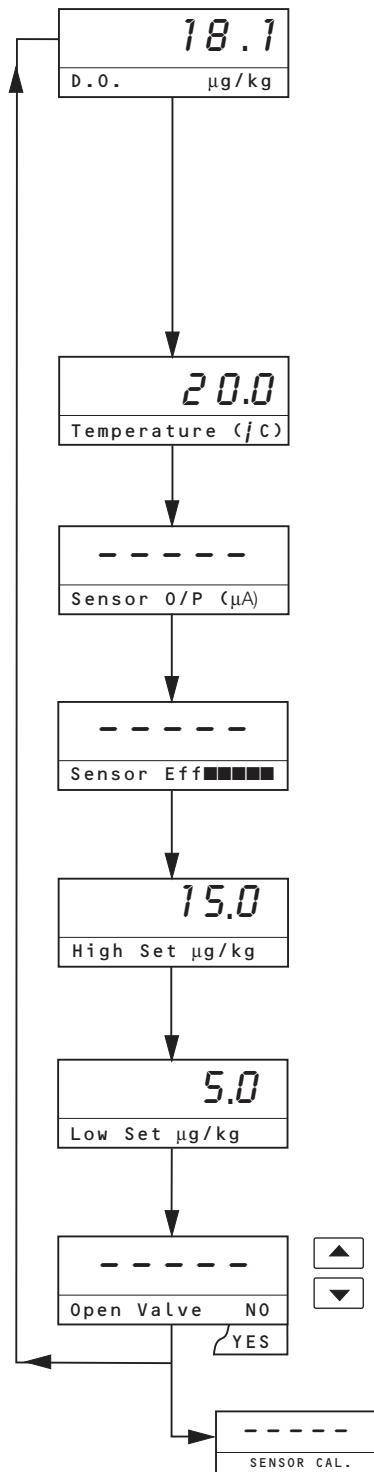

Measured Dissolved Oxygen

The measured dissolved oxygen is displayed in µg/l, mg/l, ppb, ppm, mg/kg or µg/kg.
Auto ranging:

- 0.0 to 99.9 µg kg⁻¹
- 100 to 999 µg kg⁻¹
- 1.00 to 9.99 mg kg⁻¹
- 10.0 to 20.0 mg kg⁻¹

Press to advance to next parameter or press to advance to **Calibration Page**, see section 6.2.2, page 19.

Sample Temperature

The sample temperature is displayed in either °C or °F – see section 7.1, page 20.

Sensor Output

Raw current signal (µA) generated by the sensor.

Sensor Efficiency

Bar graph indication of the sensor performance, based on last calibration – see section 6.2.2, page 19.

High Setpoint

The High alarm setpoint value is only visible if the alarm is programmed for either D.O. or Temperature and is set to High or High/Low.

Low Setpoint

The Low alarm setpoint value is only visible if the alarm is programmed for either D.O. or Temperature and is set to Low or High/Low.

Open Valve

Manually open the calibration valve to drain the flowcell prior to accessing the sensor. The reading displayed when the valve is open does not represent the dissolved oxygen content of air-saturated water at the prevailing ambient temperature.

Advance to **Calibration Page**, see section 6.2.2, page 19.

6.2.2 Calibration Page

Calibration involves standardizing the instrument and the sensor by exposing the sensor to air. During a calibration, retransmission and alarm outputs are automatically held to prevent inadvertent operation of ancillary equipment.

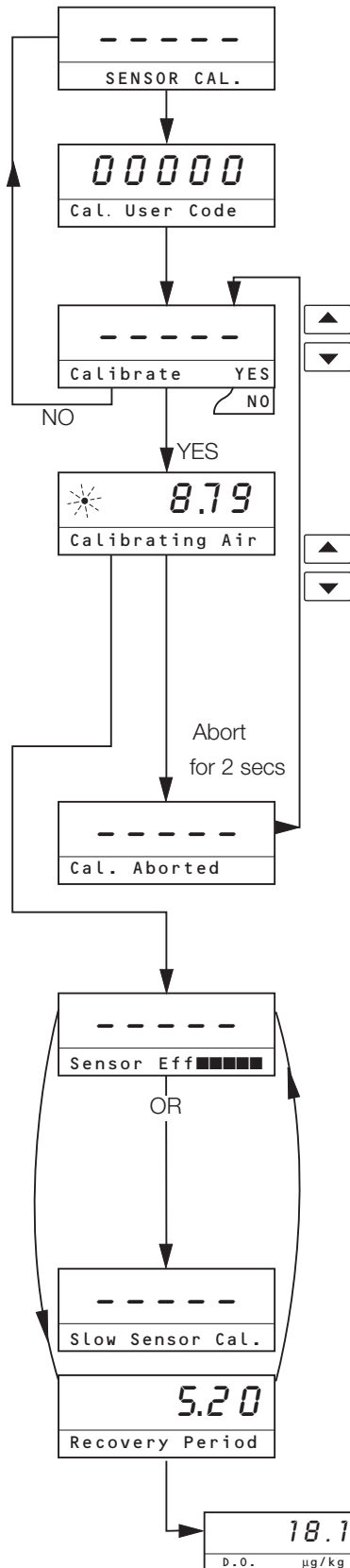

Press **[F1]** to advance to next parameter

or

Press **[F2]** to return to **Operation Page**, see section 6.1, page 17.

Calibration Access

Enter the required calibration code number, between 00000 and 19999. If an incorrect value is entered, access to calibration is prevented and **Calibration Page** is displayed.

Select YES to enable manual calibration and press **[F1]** to start the calibration sequence.

Calibrating in Air

The calibration valve opens exposing the sensor to air. A flashing dot indicates that a calibration is in progress and the displayed value is the sensor reading based on the LAST calibration. See timings below.

Wait Period Where the sensor is exposed to air before the stability of the sensor is checked. This is preset at 2 minutes (Cal Time 1).

Stability Period The readings are monitored for between 1 and 5 minutes until a stable response is achieved.

When stability has been achieved the calibration valve closes allowing sample to flow past the sensor

Abort Calibration

Pressing **[F1]** during **Calibrating in Air** aborts the calibration and the **Cal. Aborted** message is displayed for 2 seconds. The calibration valve closes allowing the sample to flow past the sensor again.

Note that the **A2 LED** continues to indicate that a calibration is in progress, and will do so for the duration of the programmed recovery period.

Sensor Efficiency

A five-bar display provides an indication of the sensor's performance.

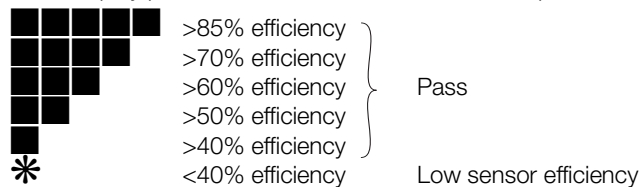

Slow Sensor Response

If the output from the sensor does not stabilize during the 1 to 5 minute stability period the calibration will not be accepted and **Slow Cal.** will be displayed.

Recovery Period

Shows the sample reading as the sensor recovers at the lower sample value. The Recovery Period is preset at 30 minutes (Cal Time 2).

The display automatically returns to the **Operating Page** at the end of this period.

7 PROGRAMMING AND ELECTRICAL CALIBRATION

7.1 Access to Secure Parameters

A 5-digit security code is used to prevent tampering with the secure parameters.

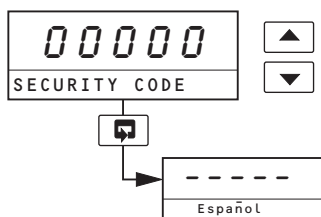

Security Code

Enter the required code number between 00000 and 19999 to gain access to the secure parameters. If an incorrect value is entered, access to subsequent programming pages is prevented and the display reverts to the **Operation Page**.

Advance to **Language Page**, see section 7.2, page 20.

7.2 Language Page

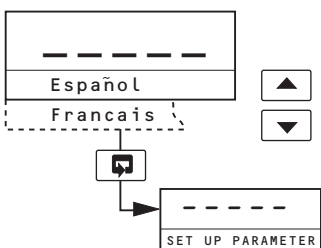

Language Page

Select the language to be displayed on all subsequent pages: Español, Français, Deutsch or English.

Advance to **Set Up Parameters Page**, see section 7.3, page 21.

7.3 Set Up Parameters Page

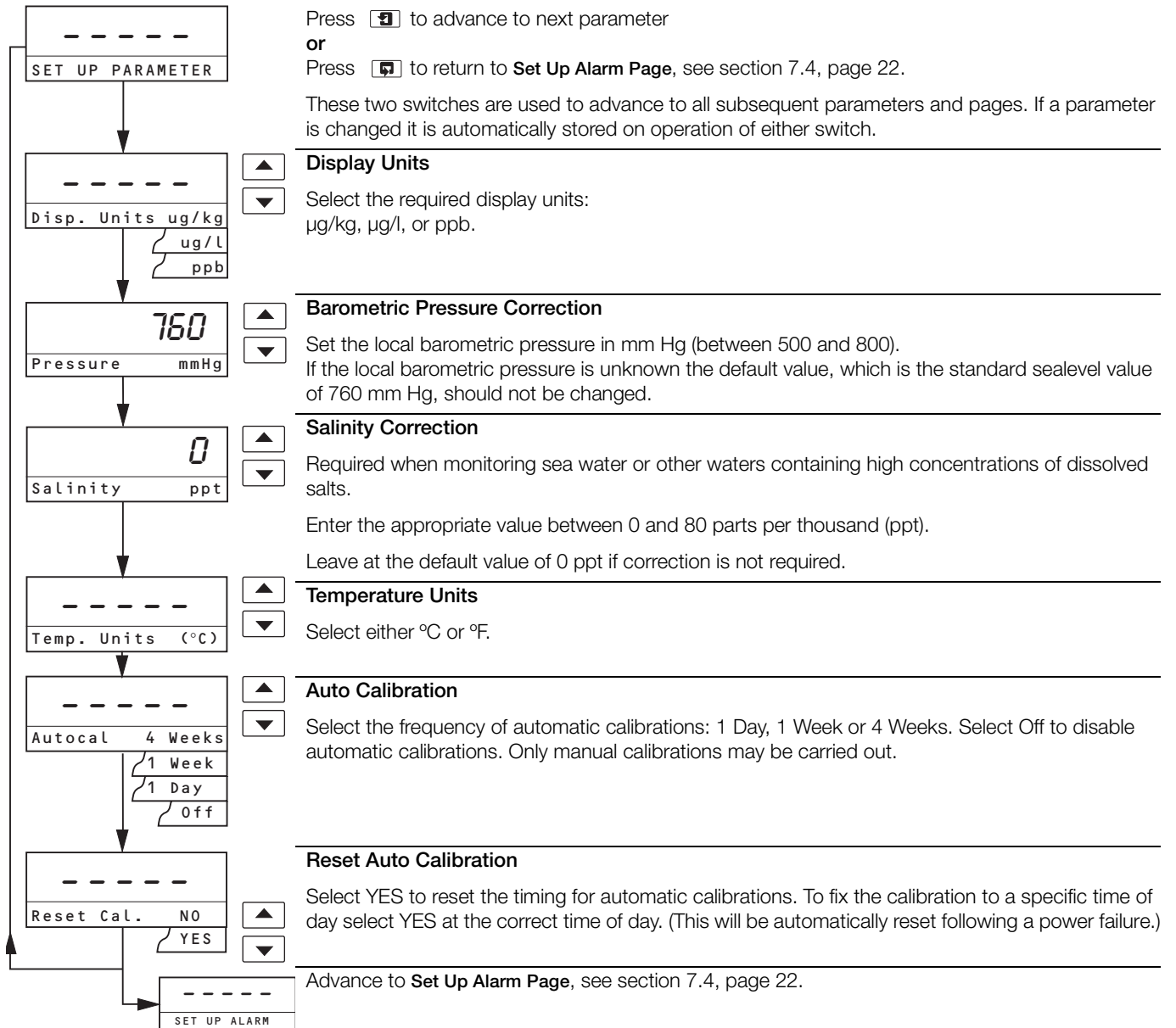

7.4 Set Up Alarm Page

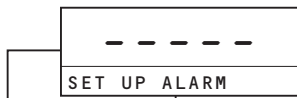

Press **[F1]** to advance to next parameter
or
Press **[F2]** to return to **Set Up Retrans Page**, see section 7.5, page 24.

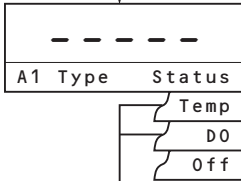

Alarm Type

Select the type of alarm required. For Status, Temp and DO alarm types, the alarm l.e.d. is off and the relay energized during normal conditions. In a fail condition, the l.e.d. is on and the relay de-energized.

- Status** The instrument alerts the operator to a power failure, a condition that causes any of the error messages listed in Table 9.1 to be displayed, or the status of a calibration.
Calibration Fail will cause the Relay and LED to pulse every second.
- Temp** The instrument alerts the operator if the temperature of the process fluid exceeds or drops below the set point value parameter, depending on the type of Alarm Action selected below.
- D.O.** The instrument alerts the operator if the Dissolved Oxygen value of the sample exceeds or drops below the set point value parameter, depending on the type of Alarm Action selected below.
- Off** If selected, no alarm is set and the alarm l.e.d. is off and the relay de-energized at all times.

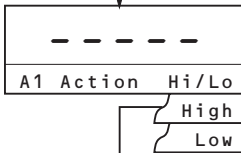

Alarm Action

For 'Fail-safe' alarm operation the relay's alarm state must be the same as the powerdown state, i.e. the relay is de-energized.

For **High** alarm operation the relay must be energized below the alarm set point.

For **Low** alarm operation the relay must be energized above the alarm set point.

The alarm LEDs are illuminated in the alarm condition.

| Alarm Action | LED Action for Input Above Set Point | LED Action for Input Below Set Point | Relay Action for Input Above Set Point | Relay Action for Input Below Set Point |
|--------------|--------------------------------------|--------------------------------------|--|--|
| High | ON | OFF | De-energized | Energized |
| Low | OFF | ON | Energized | De-energized |

Hi/Lo Alarm activates above the **High Set Point** or below the **Low Set Point**.

High Alarm activates above the **High Set Point**.

Low Alarm activates below the **Low Set Point**.

The set point band is defined as the actual value of the set point plus or minus the hysteresis value. The hysteresis value is $\pm 1\%$ of the **Alarm 1 Set Point**. Alarm action occurs if the input value is above or below the set point band. If the input moves within the set point band, the last alarm action is maintained.



Continued on next page...

...Continued from A1 Action

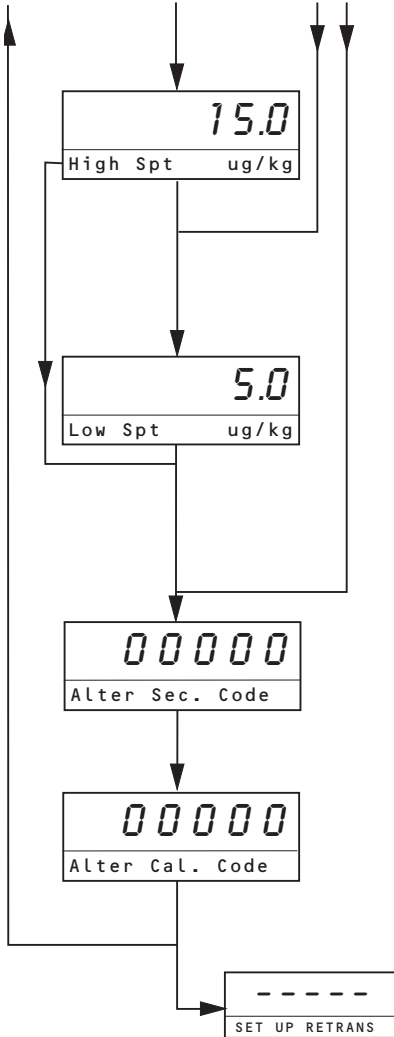

High Set Point

The **High** set point can be set to any value within the full measurement range, with the units automatically changing.

The set point value is subject to hysteresis as detailed above.

Set the alarm set point to the required value.

Displayed only if **Alarm Action** is set to **High** or **Hi/Lo**.

Low Set Point

The **Low** set point can be set to any value within the full measurement range, with the units automatically changing.

The set point value is subject to hysteresis as detailed above.

Set the alarm set point to the required value.

Displayed only if **Alarm Action** is set to **High** or **Hi/Lo**.

Alter Secure Parameters Security Code

Set the secure parameters security code to a value between 00000 and 19999.

IMPORTANT – YOU MUST MEMORIZE THE NEWLY SET SECURITY CODE. If it is forgotten contact the Company for advice.

Alter D.O. Sensor Calibration Security Code

Set the pH calibration security code to a value between 00000 and 19999.

IMPORTANT – YOU MUST MEMORIZE THE NEWLY SET SECURITY CODE. If it is forgotten contact the Company for advice.

Advance to **Set Up Retransmission Page**, see section 7.5, page 24.

7.5 Set Up Retransmission Page

In this section the actual values denoted by 'xxxxx' are unimportant and are used to determine display reading stability when carrying out the electrical calibration procedure.

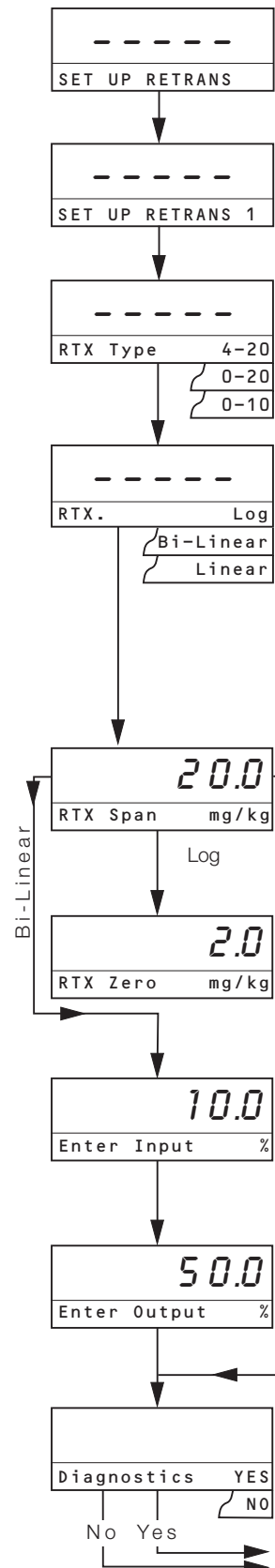

Press to advance to next parameter
 or
 Press to return to **Factory Settings Page**, see section 7.7, page 28.

Set Up Retransmission 1

Retransmission 1 Output Range
 The retransmission 1 output can be selected from three mA current ranges to ensure compatibility with the peripheral device connected. Select the current range required for retransmission 1 output.

Retransmission 1 Output Scale
 Select the retransmission output scale required.
 Log (logarithmic) – see Fig. 7.2.
 Bi-Linear – see Fig. 7.1.
 Linear

Note for Bi-linear and log scales. The accuracy specification of the instrument should always be given consideration when setting the scale limits to avoid impractical discrimination on the retransmission output.

Retransmission 1 Span

The span current output can be set to any value between:

| | |
|-----------|--|
| Linear | 20 $\mu\text{g kg}^{-1}$ and 20 mg kg^{-1} |
| Bi-Linear | 20 $\mu\text{g kg}^{-1}$ and 20 mg kg^{-1} |
| Log | 100 $\mu\text{g kg}^{-1}$ and 20 mg kg^{-1} |

Retransmission 1 Zero

The zero current output can be set to any value between 1.0 $\mu\text{g kg}^{-1}$ and 200 $\mu\text{g kg}^{-1}$. This is available only for logarithmic output.

Note. For linear output, the zero value is always 0 mg kg^{-1}

Enter Input %

Set the percentage of the display span at which the breakpoint occurs: 1.0 to 100% in 0.1% increments. This is point A on Fig. 7.1.

Enter Output %

Set the percentage output at which the breakpoint occurs: 0.0 to 100% in 0.1% steps. This is point B on Fig. 7.1.

Diagnostics

Select whether the current output diagnostics are required. See Appendix B.

Continued on next page...

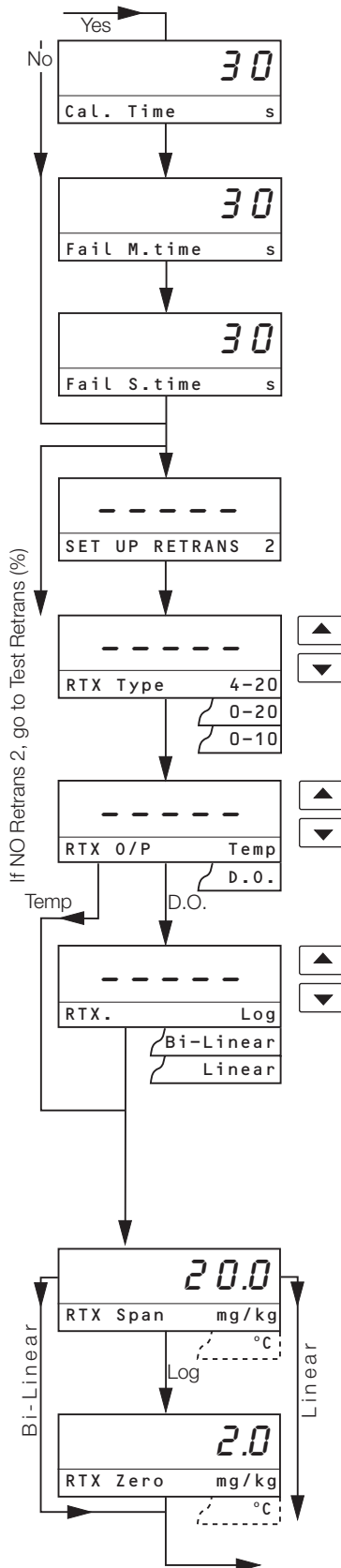

Calibration Pulse time

Set the frequency of the calibration pulse signal. Programmable frequency of 15, 30, 45 seconds, 1, 2, 3, 4, 5 minutes. See Appendix B.

Calibration Fail Mark Time

Set the mark time period for the current output to be driven hard upscale. Programmable period of 30 seconds, 1, 2, 3, 4, 5, ..., 10 minutes. See Appendix B.

Calibration Fail Space Time

Set the space time period for the current output to be driven to 0%. Programmable period of 30 seconds, 1, 2, 3, 4, 5, ..., 10 minutes. See Appendix B.

Set Up Retransmission 2 – see also Table 7.1.

Note. Available only on 9438 800 series instruments.

Retransmission 2 Output Range

The retransmission 2 output can be selected from three mA current ranges to ensure compatibility with the peripheral device connected. Select the current range required for retransmission 2 output.

Retransmission 2 Output Assignment

Select the Retransmission output required:
Temp – Temperature
D.O. – Dissolved Oxygen

Retransmission 2 Output Scale

Select the retransmission output scale required. Only available if D.O. selected.
Log (Logarithmic) – see Fig. 7.2.
Bi-Linear – see Fig. 7.1.
Linear

Note for Bi-linear and log scales. The accuracy specification of the instrument should always be given consideration when setting the scale limits to avoid impractical discrimination on the retransmission output.

Retransmission 2 Span

Set the span to the required value. See Table 7.1 for details.

Retransmission 2 Zero

Set the zero to the required value. See Table 7.1 for details.

Continued on next page...

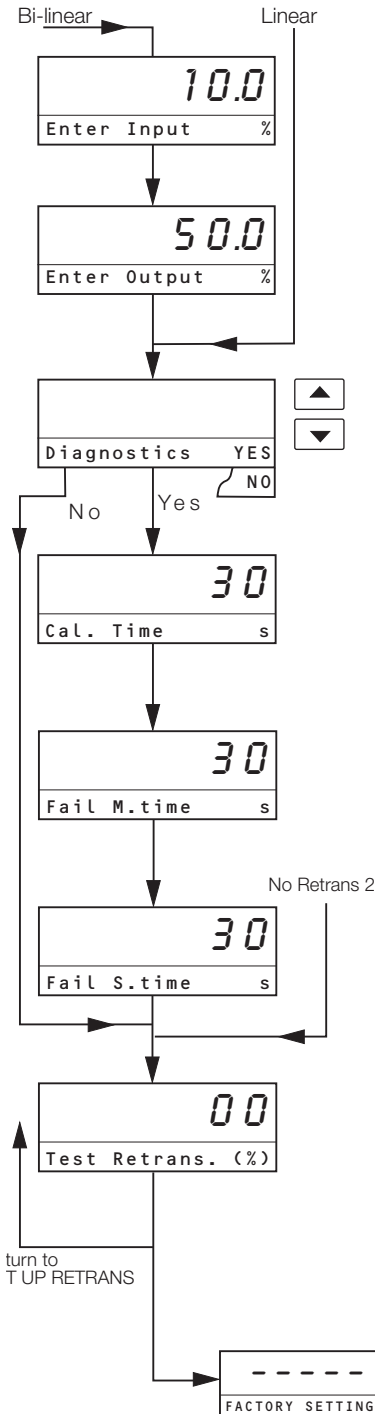

Enter Input %

Set the percentage of the display span at which the breakpoint occurs: 1.0 to 100% in 0.1% increments. This is point A on Fig. 7.1.

Enter Output %

Set the percentage output at which the breakpoint occurs: 0.0 to 100% in 0.1% steps. This is point B on Fig. 7.1.

Diagnostics

Select whether the current output diagnostics are required. See Appendix B.

Calibration Pulse Time

Set the frequency of the calibration pulse signal. Programmable frequency of 15, 30, 45 seconds, 1, 2, 3, 4, 5 minutes. See Appendix B.

Calibration Fail Mark Time

Set the mark time period for the current output to be driven hard upscale. Programmable period of 30 seconds, 1, 2, 3, 4, 5, ...,10 minutes. See Appendix B.

Calibration Fail Space Time

Set the space time period for the current output to be driven to 0%. Programmable period of 30 seconds, 1, 2, 3, 4, 5, ...,10 minutes. See Appendix B.

Test Retransmission Output

The instrument automatically transmits a test signal of 0, 25, 50, 75 or 100% of the retransmission range selected above. The % test signal selected is shown on the upper display.

Example – for a selected range of 0 to 20 mA and 50% retransmission test signal, 10 mA is transmitted.

Select the required retransmission test signal.

Advance to Factory Settings Page, see section 7.7, page 28.

| Retransmission 2 Output Assignment | Retransmission 2 Zero | Retransmission 2 Span |
|--|--|---|
| Dissolved Oxygen | Linear = 0 mg kg ⁻¹ Bi-Linear = 0 mg kg ⁻¹ Log = 1.0 µg kg ⁻¹ and 200 µg kg ⁻¹ | Linear = 20 µg kg ⁻¹ and 20 mg kg ⁻¹ Bi-Linear = 20 µg kg ⁻¹ and 20 mg kg ⁻¹ Log = 100 µg kg ⁻¹ and 20 mg kg ⁻¹ |
| Temperature (°C) (Subject to minimum range of 20°C) | 5 (minimum) | 55 (maximum) |
| Temperature (°F) (Subject to minimum range of 36°F) | 41 (minimum) | 131 (maximum) |

Table 7.1 Retransmission 2

7.6 Electrical Calibration

Note. The instrument is calibrated by the company prior to despatch and an electrical calibration should be carried out only if the accuracy of the instrument is suspect and suitably calibrated test equipment is available.

7.6.1 Equipment Required

1. Current source: 0 to +100 µA.
2. Decade resistance box (temperature input simulator): 0 to 1 k 5 Ω.
3. Digital milliammeter (current output measurement): 0 to 20 mA.

Note. Resistance boxes have an inherent residual resistance which may range from a few milliohms up to 1 ohm. This value must be taken into account when simulating input levels, as should the overall tolerance of the resistors within the boxes.

7.6.2 Preparation

1. Switch off the supply and disconnect the sensor, temperature compensator and current output from the electronics unit terminal block – see Fig. 3.5 or Fig. 3.6.
2. Connect the current source / resistance box to the appropriate terminals – see Table 7.2.
Connect the milliammeter to the retransmission output terminals – see Fig. 3.5 or Fig. 3.6.
3. Switch on the supply and allow ten minutes for the circuits to stabilize.
4. Select the **Factory Settings Page** and carry out the procedure in Section 7.7.

| Instrument Type | Terminal | | | | | | |
|-----------------|-------------------|----|-------------------|---|--------------|------------------------|--------------|
| | 1 | 2 | 3 | 4 | 5 | 6 | 7 |
| Wall Mounted | 1 | 2 | 3 | 4 | 5 | 6 | 7 |
| Panel Mounted | 12 | 11 | 10 | 9 | 8 | 7 | 6 |
| | +ve current input | | -ve current input | | PT1000 input | Link to terminal 7 (6) | PT1000 input |

Table 7.2 Transmitter Terminal Functions

7.7 Factory Settings Page

When carrying out the electrical calibration procedure, the actual values denoted by xxxxx are unimportant and are used only to determine display reading stability.

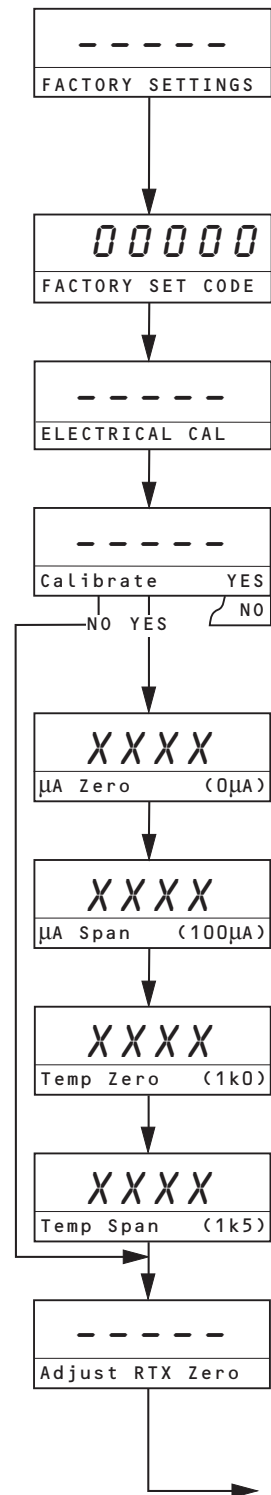

Press to advance to next parameter

or

Press to return to **Operating Page**, see section 6.2.1, page 18.

Parameters in these pages are factory set and should not normally require adjustment. They can be set up only if the necessary equipment is available.

Factory Settings Access Code

Enter the required code number. If an incorrect value is entered, access to subsequent parameters is prevented and the display reverts to the top of the page.

Select YES to access the electrical calibration sequence. Select NO to advance to **Cal Time 1**.

Caution. Do not select YES unless instrument calibration is required.

Microamp Zero

Set the current source to 0 μA and allow the instrument display to stabilize.

Microamp Span

Set the current source to +100 μA and allow the instrument display to stabilize.

Calibrate Temperature Zero

Set the temperature simulator resistance box to 1000 and allow the instrument display to stabilise.

Calibrate Temperature Span

Set the temperature simulator resistance box to 1500 and allow the instrument display to stabilise.

Adjust Retransmission Zero

Set the milliammeter reading to 4.00 mA.

Note. Retransmission signal span is calibrated using 20.00 mA. The correct value transmitted depends on the range selected in the **Set Up Outputs Page**.

Continued on next page...

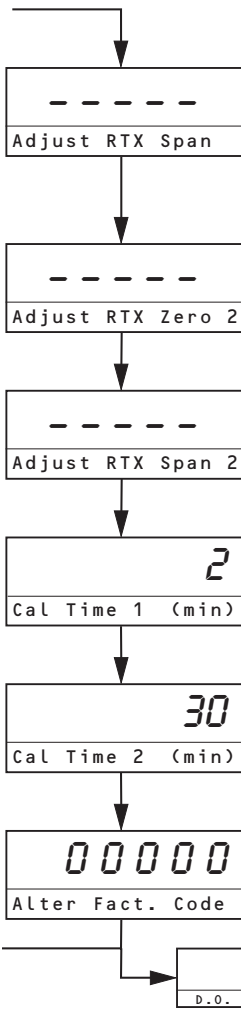

Adjust Retransmission Span

Set the milliammeter reading to 20.00 mA.

Note. Retransmission signal span is calibrated using 20.00 mA. The correct value transmitted depends on the range selected in the **Set Up Outputs Page**.

Adjust Retransmission Zero 2

See **Adjust Retransmission Zero**.

Adjust Retransmission Span 2

See **Adjust Retransmission Span**.

Calibration Time 1

Wait period before the stability of the sensor is checked during the calibration sequence. Programmable from 1 to 10 minutes (default = 2 minutes), see section 7.5, page 24.

Calibration Time 2

Recovery period where the sample is allowed to flow and the instrument settles on reading, before the instrument is brought back on-line (default = 30 minutes), see section 7.5, page 24.

Alter Factory Setting Security Code

Set the security code to a value between 00000 and 19999.

Return to **Operating Page**, see section 6.2.1, page 18.

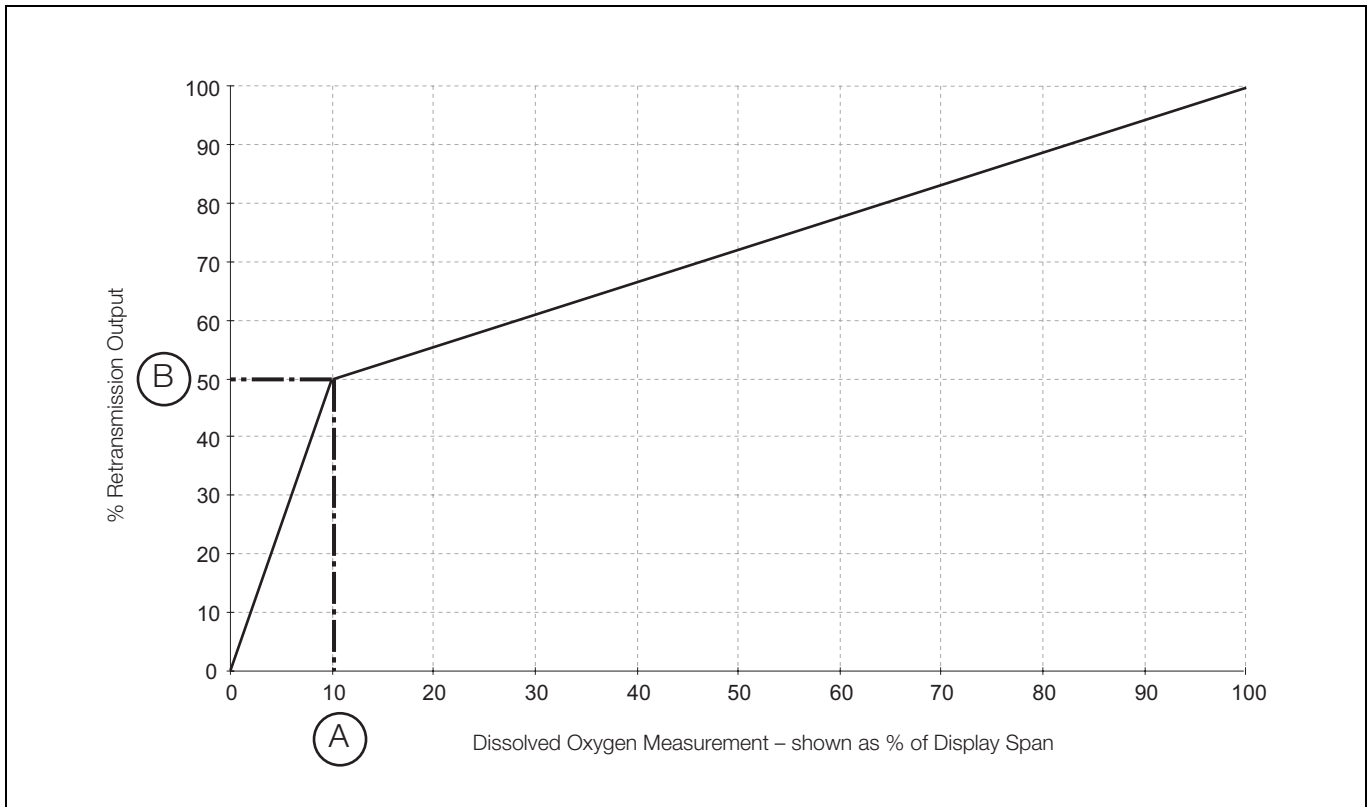

Fig. 7.1 Bi-Linear Scaling

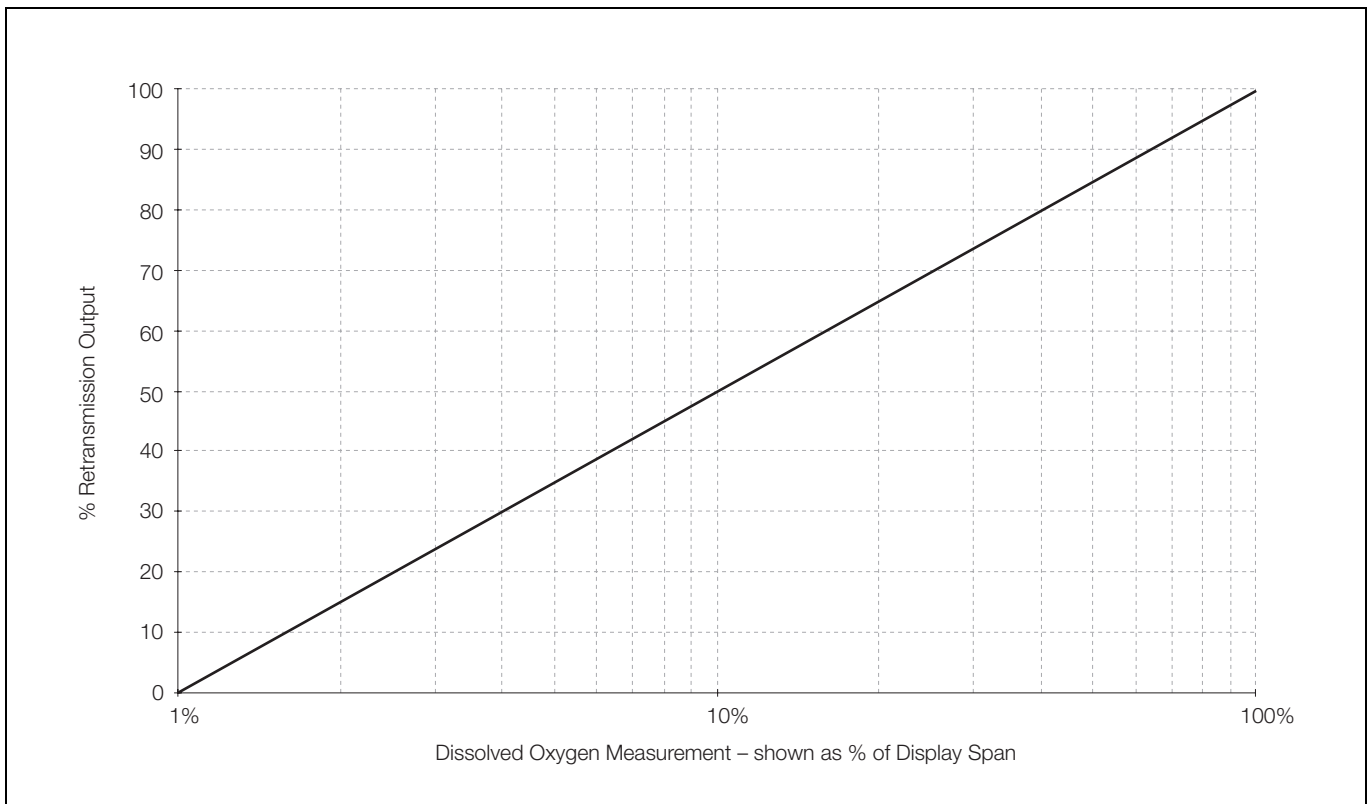

Fig. 7.2 Logarithmic Scaling (two decades example)

8 MAINTENANCE

8.1 Introduction

No routine maintenance is required for this instrument other than periodic calibration – see section 6.2.2, page 19. However, if following a calibration the sensor output shows one flashing bar, the sensor capsule has therefore become exhausted and needs replacing immediately.

If the output shows two bars, replace the sensor capsule in the near future.

Note. Storage.

DO:

- use sensors in date rotation to prevent them being stored longer than necessary.
- at all times, store sensors in a dry and cool environment.
- store sensors in a refrigerator to extend their life, but DO NOT allow them to freeze.

DO NOT:

- allow sensors to dry out, either in storage or in use.
- leave sensors in vehicles where they are likely to freeze or be exposed to high temperatures.
- leave sensors on-site without protection from direct sun or high temperatures.
- use the sensor if it's sealed environment has dried out.

A dirty membrane may also be the cause of the low sensor output. To clean the sensor proceed with the following.

Caution.

- Only install the oxygen sensor immediately prior to use, otherwise leave it stored in its protective container.
- Take special care to line up the two pins in the oxygen sensor with their respective sockets before making the connection and tightening.
- Take care not to damage the delicate membrane on the end of the oxygen sensor.
- Ensure that the mating surfaces (carrying the electrical connection) of the oxygen sensor and connector body are clean and **completely** dry.

8.2 Cleaning/Changing the Sensor

8.2.1 Cleaning

1. Drain the flowcell, by manually opening the solenoid valve – Select YES to 'Open Valve' on the main operating page of the transmitter – see section 6.2.1, page 18.
2. Unscrew the clamping screw and carefully remove the sensor assembly from the flowcell. Check that O-ring does not fall out.
3. Inspect the sensor. If the membrane is clean, refit the sensor as in 5) below.

If deposits are visible on the membrane, remove by gently wiping the membrane with a moist paper tissue; for oily or greasy deposits, the tissue may be moistened with a mild detergent or, if necessary with iso-propyl alcohol (propan-2-ol). After cleaning, dry the interior of the flowcell with a paper tissue or soft cloth, ensure that the O-ring is correctly positioned.

4. Insert the sensor assembly into the flowcell.
5. Use the clamp screw to secure the assembly. Screw in firmly using finger pressure only.

Caution. Do not overtighten the clamping screw.

6. Close the solenoid valve – Select NO to 'Open Valve' on the main operating page of the transmitter – see section 6.2.1, page 18.
7. Carry out a calibration – see section 6.2.2, page 19. If a low sensor efficiency is displayed, see section 9.2, page 34.

8.2.2 Changing the Sensor

1. Drain the flowcell, by manually opening the solenoid valve
– Select YES to 'Open Valve' on the main operating page of the transmitter, see section 6.2.1, page 18.
2. Unscrew the clamping screw and remove the sensor assembly from the flowcell.
3. Disconnect the sensor capsule and discard both the sensor and sealing washer.
4. Take out the O-ring from the flowcell; dry the interior of the flowcell with a tissue or soft cloth and insert the new O-ring supplied with the replacement capsule. Ensure that the O-ring is correctly located on the shoulder near the end of the cavity.
5. Remove the new sensor from its container, taking care not to damage the membrane. Unscrew the protective cap from the rear of the sensor.
6. Fit the new sealing washer (supplied) as shown in Fig. 4.1 and locate and secure the connector body on the sensor.
7. Insert the complete assembly into the flowcell.
8. Use the clamping screw to secure the assembly. Screw in firmly using finger pressure only.

Caution. Do not overtighten the clamping screw.

9. Close the solenoid valve – Select NO to 'Open Valve' on the main operating page of the transmitter, see section 6.2.1, page 18.
10. Carry out a calibration – see section 6.2.2, page 19. If a low sensor efficiency is displayed, see section 9.2, page 34.

9 SIMPLE FAULT FINDING

9.1 Diagnostic Messages

If erroneous or unexpected results are obtained the fault may be indicated by an error message. If Alarm A1 has been selected as a STATUS alarm, then the LED and relay operation can be seen in Table 9.1. The STATUS alarm operates as a FAILSAFE alarm (during an alarm condition the relay state is the same as the power-down state, i.e. de-energized).

| Diagnostic Message | STATUS Alarm A1 | | Possible Cause | Remedy |
|--------------------------|--------------------|--------------------------------------|---|--|
| | LED Action | Relay Action (Fail-safe) | | |
| Flashing Display | OFF | Energized | Reading is outside of the measuring range 0 to 20 mg Kg ⁻¹ . | See Sections 9.2 & 9.3. |
| LOW SENSOR EFF. | ON/OFF (1s period) | De-energized / energized (1s period) | Output from D.O. sensor during calibration less than 40 % of expected output. | See Section 9.2. |
| SLOW SENSOR CAL. | ON/OFF (1s period) | De-energized / energized (1s period) | Output from D.O. sensor during calibration not achieving required stability. | See Section 9.2. |
| Calibrating in Air | ON | De-energized | Displayed during calibration when sensor is exposed to air. | – |
| Recovery Period | ON | De-energized | Displayed after calibration whilst waiting for sensor to stabilize on sample. Duration of 30 minutes (Cal Time 2). | – |
| COLD (Solution too cold) | ON | De-energized | Sample temperature <5 °C. | If sample temperature is not <5 °C, check the temperature input of the transmitter – see section 9.3, page 34. If fault persists contact the Company. |
| HOT (Solution too hot) | ON | De-energized | Sample temperature >55 °C. This causes the calibration valve to open and drain the flowcell to prevent damage to the sensor. After 30 minutes the valve closes and the sample temperature is measured again. This process continues until the sample temperature is <55 °C. | If sample temperature is not >55 °C, check the temperature input of the transmitter – see section 9.3, page 34. If fault persists contact the Company. |
| FAULTY PT1000 | ON | De-energized | Temperature compensator/ associated connections are either open or short circuit. | Check that all signal connections are made. If fault persists, check for a response to a temperature input – see section 9.3, page 34. |
| INVALID INPUT | ON | De-energized | Input signal is outside of measuring range of the electronics. | Check that instrument responds to an input signal by carrying out an electrical calibration as described in Section 7.6. |
| NV MEMORY ERROR | ON | De-energized | Contents of non-volatile memory have not been read correctly during power up. | Switch off transmitter, wait 10 seconds and switch on again. If fault persists contact the Company. |

Table 9.1 Diagnostic Messages

9.2 Low Sensor Efficiency/Slow Sensor Cal. or No Response to D.O. Changes

1. Check that the sample drains fully from flowcell. If the sample does NOT drain fully check:
 - a. Operation of solenoid valve.
 - b. Sample inlet flow rate does not exceed 400 ml min⁻¹ maximum.
 - c. Sample fluid paths are free flowing and clear of partial blockages.
 - d. Solenoid valve drain tube is not kinked, blocked, excessively long, does no rise along its length.
 - e. Flow gauge is not blocked or dirty.
2. Replace the sensor (see section 8.2.2, page 32) as an initial check. It is also important that all program parameters have been set correctly and have not been altered inadvertently – see section 7, page 20.

If the fault persists:

3. Carry out an electrical calibration as detailed in Section 7.6 and check that the instrument responds correctly to the current input.
Failure to respond to the input usually indicates a fault with the transmitter, which must be returned to the Company for repair.
4. If the response in a) is correct, select the Operating Page and set the current source to a value which gives an on-scale D.O. reading on the transmitter. Make a note of the current source setting and the D.O. reading. Reconnect the sensor cable and connect the current source to the sensor end of the cable. Set the same current value on the source and check that the transmitter displays the noted reading in this configuration.

If check 1 is correct but check 2 fails, check the cable connections and condition. If the response for both checks is correct, fit a new sensor and calibrate it.

9.3 Checking the Temperature Input

Check that the instrument responds to a temperature input. Disconnect the PT1000 leads and connect a suitable resistance box directly to the transmitter inputs – see section 7.6, page 27. Check that the transmitter displays the correct values as set on the resistance box – see Table 9.2.

Incorrect readings usually indicate an electrical calibration problem. Recalibrate the instrument – see section 7.6, page 27.

9.4 High Sample Readings

If the sample reading is higher than expected, the most likely reason is air ingress into the main sample line.

Check and tighten ALL sample connections as it is possible to have an air leak into the sample without sample leaking.

| Temperature (°C) | Input Resistance (Ω) |
|------------------|----------------------|
| 0 | 1000.0 |
| 10 | 1039.0 |
| 20 | 1079.3 |
| 30 | 1116.7 |
| 40 | 1155.4 |
| 50 | 1194.0 |
| 60 | 1232.4 |
| 70 | 1270.7 |
| 80 | 1308.9 |
| 90 | 1347.0 |
| 100 | 1385.0 |
| 130.5 | 1500.0 |

Table 9.2 Temperature Readings for Resistance Inputs

10 Specification

System

Measuring ranges

Electrodes

Programmable within the ranges 0 to 20.0 µg/kg and 0 to 20 mg/kg

Scaling

µg/kg, mg/kg or ppb, ppm

Accuracy

±5 % of reading or ±1 µg/kg, whichever is the greater

Response time

90 % of a step change in 1 minute

Resolution

0.1 µg/kg

Stability

±5 % of reading or ±1 µg/kg per week, whichever is the greater

Not applicable when autocalibration is in operation

Temperature compensation

5 to 55 °C (41 to 131 °F) automatic using Pt1000 resistance thermometer

Salinity correction

Preset within the range 0 to 80 PPT

Barometric pressure correction

Preset within the range 500 to 800 mm Hg

Sample flow

100 to 400 ml/min

Sample pressure

Maximum 2 bar

Sample temperature

5 to 55 °C (41 to 131 °F)

Sensor ambient temperature

0 to 55 °C (32 to 131 °F)

Autocalibration frequency

1, 7 or 28 days

Environmental Data

Operating temperature limits

-20 to 55 °C (-4 to 131 °F)

Operating humidity limits

Up to 95 % RH non-condensing

Storage temperature limits

Liquid-handling panel -25 to 70 °C (-13 to 158 °F)

Sensor 0 to 55 °C (32 to 131 °F)

Transmitter -25 to 70 °C (-13 to 158 °F)

Solenoid valve power supply -25 to 70 °C (-13 to 158 °F)

Protection

Liquid handling panel

IP65

IP54 Liquid-handling panel enclosure

Transmitter

Panel-mount IP66/NEMA4X

Wall-mount IP66/NEMA4X front

Solenoid valve power supply IP65

Power requirements

System

Power consumption <21 VA

Transmitter

Power supply 100 to 130 V or 200 to 260 V, 50/60 Hz

Power consumption <10 VA

Insulation, mains to earth

2kV RMS

Solenoid valve

Power supply 90 to 132 V or 180 to 264 V, 47/63 Hz

Power consumption <11 VA

Mechanical Data

Mounting

Transmitter Wall or panel

Liquid-handling panel/enclosure Wall

Solenoid valve power supply Wall

Overall Dimensions

Liquid handling panel

With environmental enclosure

250 x 440 x 160 mm
(9.84 x 17.32 x 6.3 in)

Without unions and without environmental enclosure

100 approx. x 310 x 118 mm
(3.94 approx. x 12.2 x 4.65 in)

Transmitter

Wall-mount 160 x 214 x 68 mm
(6.29 x 8.43 x 2.68 in)

Panel-mount 96 x 96 x 191 mm
(3.78 x 3.78 x 7.52 in)

Panel cut-out 92 x 92 mm
(3.62 x 3.62 in)

Solenoid valve power supply 92 x 92 mm
(3.62 x 3.62 in)

Weights

Liquid handling panel

With sensor fitted and with environmental enclosure
3.9 kg (8.6 lb)

With sensor fitted, without environmental enclosure
1.3 kg (2.87 lb)

Transmitter

Wall-mount 2 kg (4.41 lb)

Panel-mount 1.5 kg (3.31 lb)

Solenoid valve power supply 0.7 kg (1.54 lb)

Sample connections

Compression fitting to accept either 6 mm OD tubing or 1/4 in OD tubing – to be specified when ordering

Transmitter

Transmitter Display

Measured value

5-digit x 7-segment back-lit LCD

Information

16-character, single line, dot matrix, back-lit LCD

Insulation, contacts to earth

2 kV RMS

Set Point and Relay

No. of set points

One

Set point adjustment

Programmable as a concentration or diagnostics alarm

Set point hysteresis

±1 % of FSD (fixed) Sensor 0 to 55 °C (32 to 131 °F)

Local set point annunciation

Red LED

No. of relays

Two – one permanently assigned to the calibration solenoid valve

Relay contacts

Single pole changeover

| | | |
|---------|----------|---------------|
| Rating: | 250 V AC | 250 V DC max. |
| | 3 A AC | 3 A DC max. |

| | | |
|----------|--------|---------------------------|
| Loading: | 750 VA | 30 W max. (non-inductive) |
| | 75 VA | 3 W max. (inductive) |

Retransmission

No. of retransmission signals

One, fully isolated current output

0 to 10, 0 to 20 or 4 to 20 mA programmable

Optional second current output

0 to 10, 0 to 20 or 4 to 20 mA programmable

Maximum load resistance

500 Ω (20 mA maximum)

Serial communication

RS422/RS485 (optional, with one current output signal)

Solenoid Valve PSU

Note. Cable from the PSU to the valve is not supplied by ABB

Typical cable specification

| | |
|---------------------|---------------------|
| 3-core round | 0.5 mm ² |
| Min. current rating | 3 A |
| Construction | 16/0.2 mm |
| Nom. diameter | 5.5 to 8.5 mm |

Voltage requirements

90 to 132 V AC or
180 to 264 V AC, 47 to 63 Hz

Power consumption

<60 VA max.

Output power

24 V @ 2.5 A, 60 W max. from all outputs

Holdup time

6 ms at full load 115/230 V AC

Line regulation

0.3 % over operating range

Load regulation

0.5 % from min. load to full load

11 SPARES

Normal, replacement spares are shown in Fig. 11.1. Strategic spares are listed below.

11.1 Strategic Spares

| Part No. | Description | Qty |
|----------|---------------------------------|-----|
| 9438 080 | 24V Power Supply Unit | 1 |
| 0234 037 | Solenoid Valve assembly | 1 |
| 0216 574 | Flow Gauge assembly | 1 |
| 0216 575 | Needle Valve Cartridge assembly | 1 |

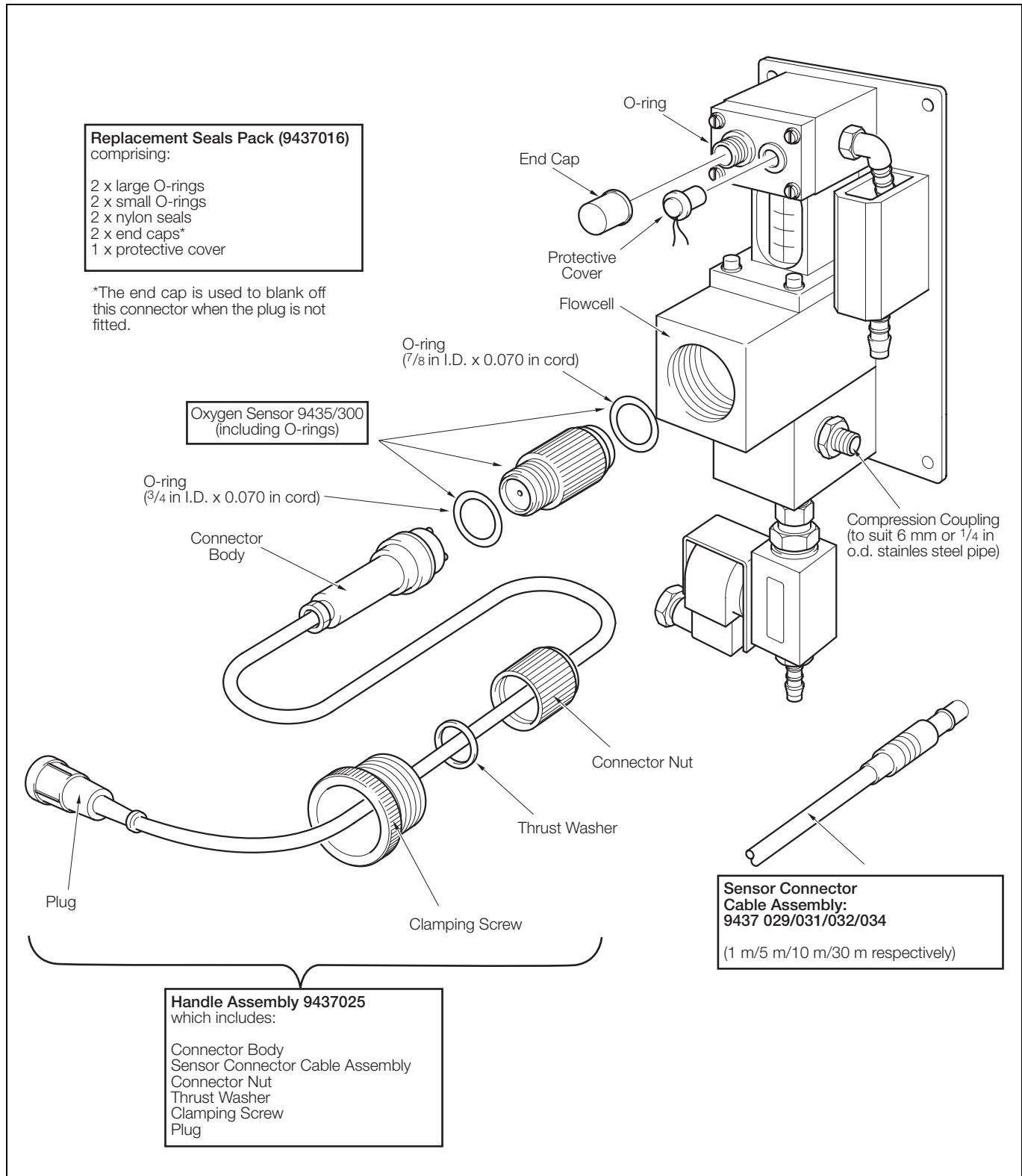

Fig. 11.1 Replacement Spares

Note. Ensure that the correct O-rings are fitted in the appropriate positions as shown.
Fit new O-rings when a new sensor is fitted.

Appendix A 9438 080 24 V DC POWER SUPPLY UNIT (OPTIONAL)

A.1 Description

The 24 V DC switch mode power supply unit is capable of powering up to four separate 9438 dissolved oxygen system solenoids. The 24 V is switched to the solenoid when required by the operation of the calibration relay in the main 9438 transmitter.

Fig. A.3 shows the connection details in the PSU.

Fig. A.4 shows the interconnection between the PSU and a single 9438 transmitter.

A.2 PSU Dimensions

Warning.

- Before making any connections, ensure that the power supply, any high voltage-operated control circuits and high common mode voltage are switched off.
- Although certain instruments are fitted with internal fuse protection, a suitably rated external protection device, e.g. fuse or miniature circuit breaker (m.c.b.), must also be fitted by the installer.

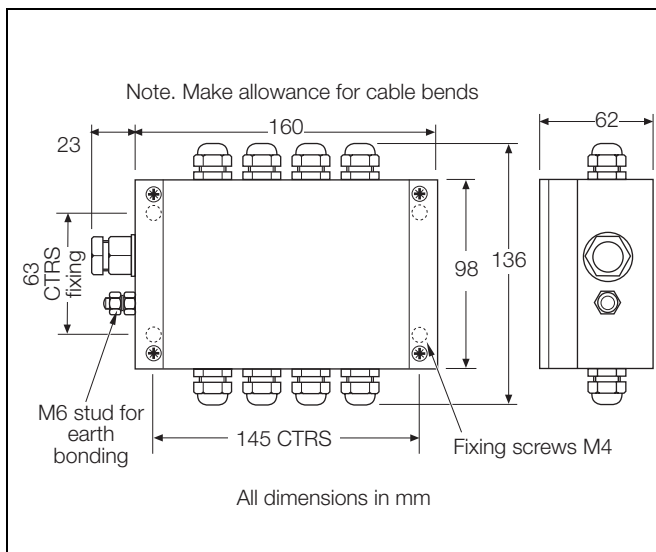

Fig. A.1 Power Supply Unit Dimensions

A.3 Accessing PSU Terminals

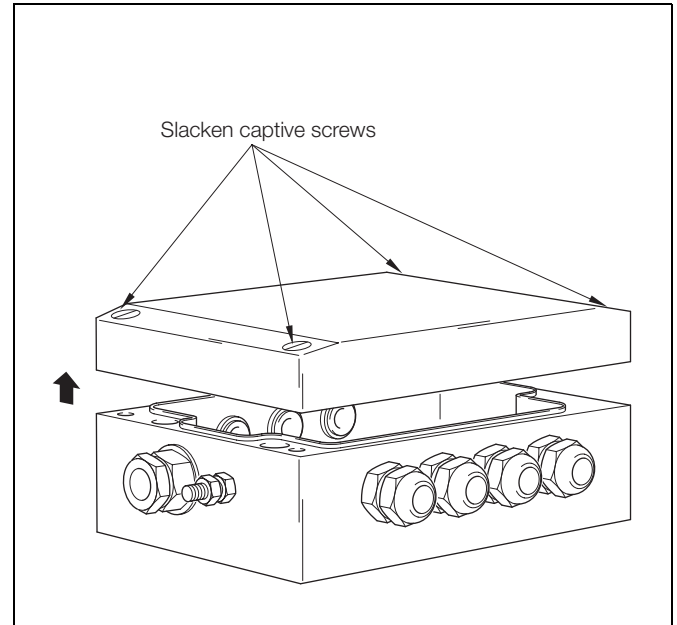

Fig. A.2 Access to PSU Terminals

A.4 PSU Connection

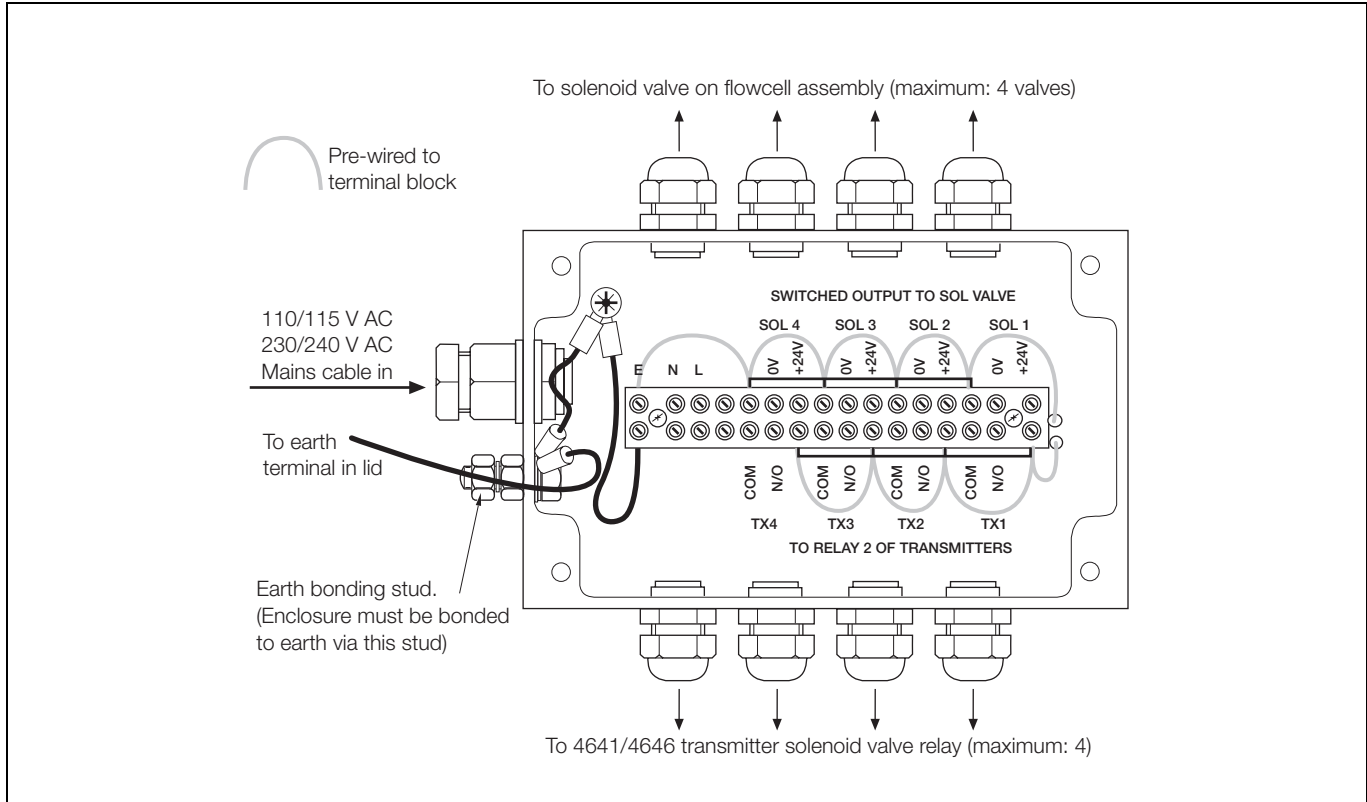

Fig. A.3 PSU Connection

A.5 Wiring Schematic

Note.

- PSU should be earth bonded.
- 0V is internally connected to earth.

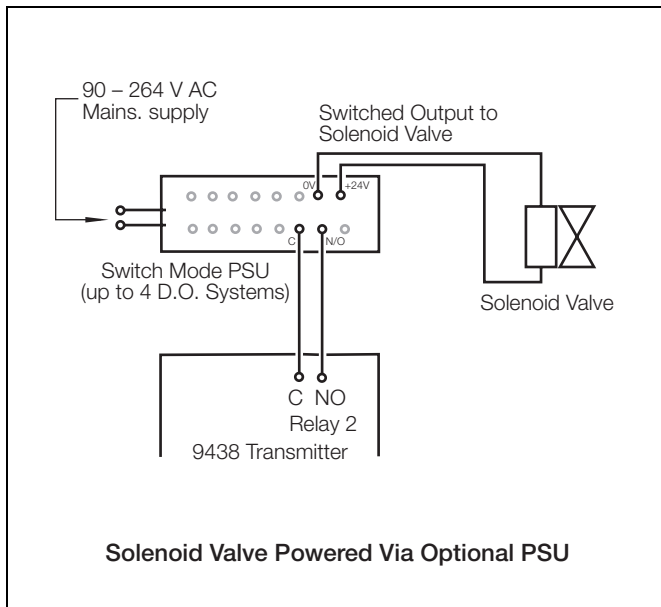

Fig. A.4 Wiring Schematic

A.6 Specification

| | |
|----------------------|--|
| Overall dimensions | 160 x 98 x 62 mm (6.3 x 3.86 x 2.44 in) |
| Output power | 24 V @ 2.5 A, 60 W maximum from all outputs |
| Holdup time | 6 ms at full load 115/230 V AC |
| Line regulation | 0.3% over operating range |
| Load regulation | 0.5% from minimum load to full load |
| Power supply | |
| Voltage requirements | 90 to 264 V AC, 47 to 63 Hz |

Appendix B CALIBRATION DIAGNOSTICS

The transmitter can be configured to enable the current output signal to indicate certain calibration diagnostic information. If the option for diagnostics is selected within the Set Up Retransmission scrolls, then the current output will indicate when a calibration is taking place, and also will indicate if the sensor is giving Low Sensor Efficiency.

B.1 During Calibration

The current output value will be maintained during a calibration, but the output will pulse from the maintained value to 0%, depending upon a programmable Cal Pulse period.

The Calibration Pulse period can be programmed 15, 30, 45 seconds, 1, 2, 3, 4, 5 minutes.

This will continue for the full duration of the calibration, exposing the sensor to air, and the recovery period. At the end of the recovery period, if the response is good, the instrument will go back on line and the current output will become live.

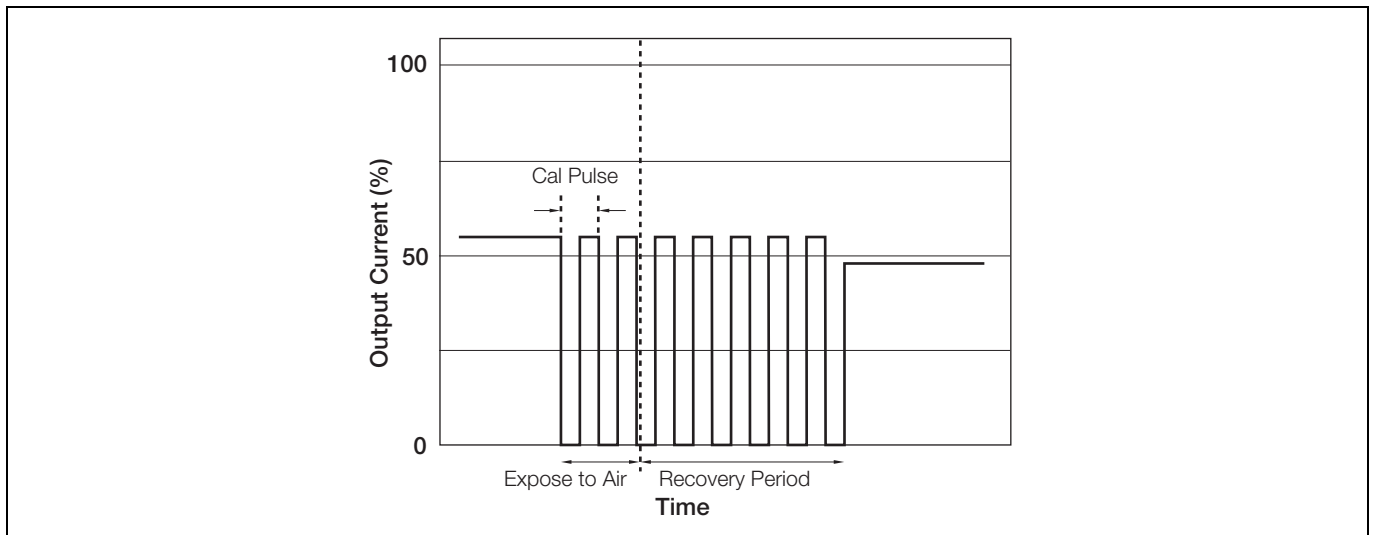

Fig. B.1 During Calibration

B.2 Low Sensor Efficiency

If the output from a sensor is found to be below a predetermined level during a calibration (i.e. Low Sensor Efficiency) the calibration will not be accepted. The current output immediately goes above the full scale value, and will continue to pulse on a programmable Mark/Space basis.

The time for the Mark and Space periods can be programmed separately to 30 seconds, 1, 2, 3.....10 minutes.

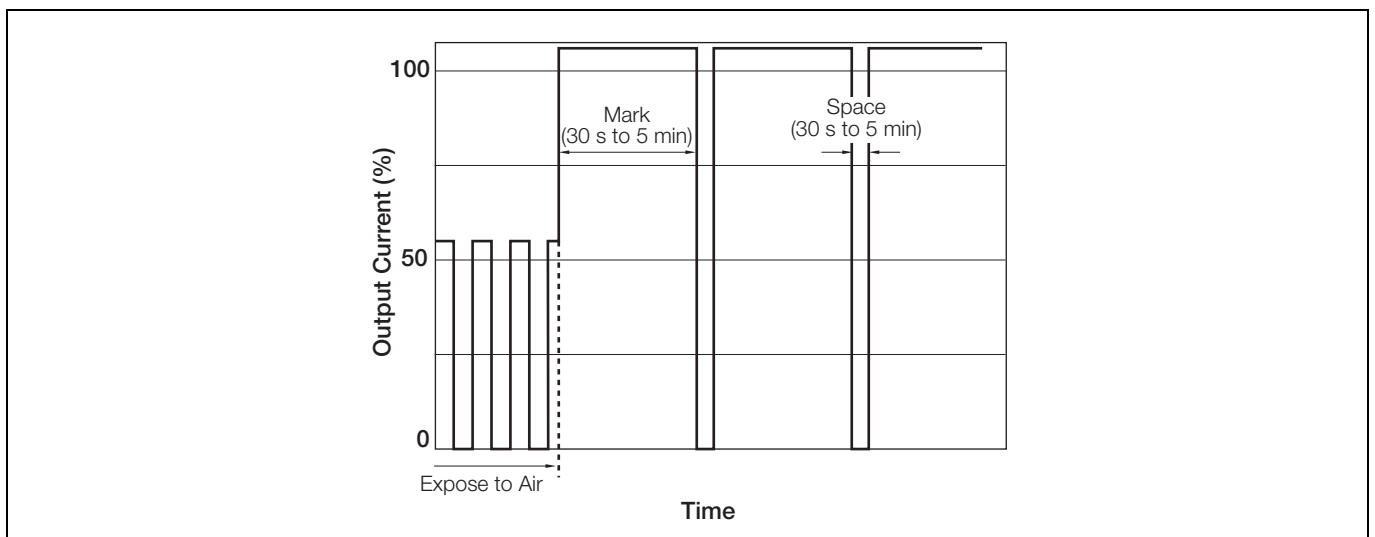

Fig. B.2 Low Sensor Efficiency

Notes

PRODUCTS & CUSTOMER SUPPORT

Products

Automation Systems

- for the following industries:
 - Chemical & Pharmaceutical
 - Food & Beverage
 - Manufacturing
 - Metals and Minerals
 - Oil, Gas & Petrochemical
 - Pulp and Paper

Drives and Motors

- AC and DC Drives, AC and DC Machines, AC Motors to 1kV
- Drive Systems
- Force Measurement
- Servo Drives

Controllers & Recorders

- Single and Multi-loop Controllers
- Circular Chart and Strip Chart Recorders
- Paperless Recorders
- Process Indicators

Flexible Automation

- Industrial Robots and Robot Systems

Flow Measurement

- Electromagnetic Flowmeters
- Mass Flowmeters
- Turbine Flowmeters
- Wedge Flow Elements

Marine Systems & Turbochargers

- Electrical Systems
- Marine Equipment
- Offshore Retrofit and Refurbishment

Process Analytics

- Process Gas Analysis
- Systems Integration

Transmitters

- Pressure
- Temperature
- Level
- Interface Modules

Valves, Actuators and Positioners

- Control Valves
- Actuators
- Positioners

Water, Gas & Industrial Analytics Instrumentation

- pH, Conductivity and Dissolved Oxygen Transmitters and Sensors
- Ammonia, Nitrate, Phosphate, Silica, Sodium, Chloride, Fluoride, Dissolved Oxygen and Hydrazine Analyzers
- Zirconia Oxygen Analyzers, Katharometers, Hydrogen Purity and Purge-gas Monitors, Thermal Conductivity

Customer Support

We provide a comprehensive after sales service via a Worldwide Service Organization. Contact one of the following offices for details on your nearest Service and Repair Centre.

UK

ABB Limited
Tel: +44 (0)1453 826661
Fax: +44 (0)1453 829671

United States of America

ABB Inc.
Tel: +1 775 850 4800
Fax: +1 775 850 4808

Client Warranty

Prior to installation, the equipment referred to in this manual must be stored in a clean, dry environment, in accordance with the Company's published specification.

Periodic checks must be made on the equipment's condition. In the event of a failure under warranty, the following documentation must be provided as substantiation:

1. A listing evidencing process operation and alarm logs at time of failure.
2. Copies of all storage, installation, operating and maintenance records relating to the alleged faulty unit.

ABB has Sales & Customer Support expertise
in over 100 countries worldwide

www.abb.com

The Company's policy is one of continuous product
improvement and the right is reserved to modify the
information contained herein without notice.

Printed in UK (03.10)

© ABB 2010



ABB Limited
Oldends Lane, Stonehouse
Gloucestershire
GL10 3TA
UK
Tel: +44 (0)1453 826661
Fax: +44 (0)1453 829671

ABB Inc.
125 E. County Line Road
Warminster
PA 18974
USA
Tel:+1 215 674 6000
Fax:+1 215 674 7183