

AX410, AX411, AX413, AX416, AX418,
AX450, AX455 & AX456

Single and dual input analyzers for low level conductivity



The Company

We are an established world force in the design and manufacture of measurement products for industrial process control, flow measurement, gas and liquid analysis and environmental applications.

As a part of ABB, a world leader in process automation technology, we offer customers application expertise, service and support worldwide.

We are committed to teamwork, high quality manufacturing, advanced technology and unrivalled service and support.

The quality, accuracy and performance of the Company's products result from over 100 years experience, combined with a continuous program of innovative design and development to incorporate the latest technology.

EN ISO 9001:2000



Cert. No. Q 05907

EN 29001 (ISO 9001)



Lenno, Italy – Cert. No. 9/90A

Stonehouse, U.K.



Electrical Safety

This equipment complies with the requirements of CEI/IEC 61010-1:2001-2 'Safety Requirements for Electrical Equipment for Measurement, Control and Laboratory Use'. If the equipment is used in a manner NOT specified by the Company, the protection provided by the equipment may be impaired.

Symbols

One or more of the following symbols may appear on the equipment labelling:

	Warning – Refer to the manual for instructions
	Caution – Risk of electric shock
	Protective earth (ground) terminal
	Earth (ground) terminal

	Direct current supply only
	Alternating current supply only
	Both direct and alternating current supply
	The equipment is protected through double insulation

Information in this manual is intended only to assist our customers in the efficient operation of our equipment. Use of this manual for any other purpose is specifically prohibited and its contents are not to be reproduced in full or part without prior approval of the Technical Publications Department.

Health and Safety

To ensure that our products are safe and without risk to health, the following points must be noted:

1. The relevant sections of these instructions must be read carefully before proceeding.
2. Warning labels on containers and packages must be observed.
3. Installation, operation, maintenance and servicing must only be carried out by suitably trained personnel and in accordance with the information given.
4. Normal safety precautions must be taken to avoid the possibility of an accident occurring when operating in conditions of high pressure and/or temperature.
5. Chemicals must be stored away from heat, protected from temperature extremes and powders kept dry. Normal safe handling procedures must be used.
6. When disposing of chemicals ensure that no two chemicals are mixed.

Safety advice concerning the use of the equipment described in this manual or any relevant hazard data sheets (where applicable) may be obtained from the Company address on the back cover, together with servicing and spares information.

Contents

1	Introduction	2	6	Installation	50
1.1	System Description	2	6.1	Siting Requirements	50
1.2	PID Control – AX410 and AX450 Analyzers Only	2	6.2	Mounting	51
1.3	AX400 Series Analyzer Options	2	6.2.1	Wall-/Pipe-mount Analyzers	51
			6.2.2	Panel-mount Analyzers	52
2	Operation	3	6.3	Connections, General	53
2.1	Powering Up the Analyzer	3	6.3.1	Relay Contact Protection and Interference Suppression	54
2.2	Displays and Controls	3	6.3.2	Cable Entry Knockouts, Wall-/Pipe-mount Analyzer	55
2.2.1	Membrane Key Functions	3	6.4	Wall-/Pipe-mount Analyzer Connections	56
2.3	Operating Page	6	6.4.1	Access to Terminals	56
2.3.1	Single Input Conductivity	6	6.4.2	Connections	57
2.3.2	Dual Input Conductivity	6	6.5	Panel-mount Analyzer Connections	58
			6.5.1	Access to Terminals	58
			6.5.2	Connections	59
3	Operator Views	9	6.6	ABB Conductivity Sensor Systems Connections	60
3.1	View Set Points	9			
3.2	View Outputs	10	7	Calibration	61
3.3	View Hardware	11	7.1	Equipment Required	61
3.4	View Software	12	7.2	Preparation	61
3.5	View Logbook	13	7.3	Factory Settings	62
3.6	View Clock	16			
4	Setup	17	8	Simple Fault Finding	68
4.1	Sensor Calibration	17	8.1	Error Messages	68
			8.2	No Response to Conductivity Changes	68
			8.3	Checking the Temperature Input	69
5	Programming	19	9	Specification	70
5.1	Security Code	19			
5.2	Configure Display	20	Appendix A – Calculations	73	
5.3	Configure Sensors	21	A.1	Automatic Temperature Compensation	73
5.4	Configure Alarms	30	A.1.1	Calculation of Temperature Coefficient	74
5.5	Configure Outputs	34	A.2	Relationship Between Conductivity and Total Dissolved Solids (TDS) Measurement	74
5.6	Output Functions	39	A.3	Inferred pH Derived from Differential Conductivity	75
5.6.1	Bi-Linear Output	39	A.3.1	Monitoring on Steam-Raising Plant	75
5.6.2	Logarithmic Output (2-decade)	39	A.3.2	Monitoring on AVT Systems	76
5.6.3	Logarithmic Output (3-decade)	40	A.3.3	Monitoring on AVT Systems with Impurities	76
5.7	Configure Clock	41	A.3.4	Monitoring on Solid Alkaline Treated Systems	77
5.8	Configure Control	42			
5.8.1	Configure Single PID Controller	43	Appendix B – PID Control	78	
5.8.2	Configure Power Failure Recovery Mode	46	B.1	Single PID Controller	78
5.9	Configure Security	47	B.1.1	Reverse Acting Single PID Control	78
5.10	Configure Logbook	47	B.1.2	Direct Acting Single PID Control	79
5.11	Test Outputs and Maintenance	48	B.2	Output Assignment	79
			B.3	Setting Up Three Term (PID) Control Parameters	80
			B.4	Manual Tuning	80

1 Introduction

1.1 System Description

The AX410 single input and AX411 dual input conductivity analyzers have been designed for continuous monitoring and control of low level conductivity.

The AX450 single input and AX455 dual input conductivity analyzers have been designed to meet United States Pharmacopoeia (USP 645) requirements for continuous monitoring and control of low level conductivity.

They are available in wall-/pipe-mount or panel-mount versions and can be used with either one or two sensors, each with a temperature input channel. When used with two sensors, readings can be compared to produce a range of extrapolated values.

When making temperature compensated measurements, the sample temperature is sensed by a resistance thermometer (Pt100 or Pt1000) mounted in the measuring cell.

Analyzer operation and programming are performed using five tactile membrane keys on the front panel. Programmed functions are protected from unauthorized alteration by a five-digit security code.

1.2 PID Control – AX410 and AX450 Analyzers Only

The AX410 and AX450 single input conductivity analyzers incorporate Proportional Integral Derivative (PID) control as standard. For a full description of PID control, see Appendix B, page 78.

1.3 AX400 Series Analyzer Options

Table 1.1 shows the range of configurations that are possible for the AX400 Series analyzers. The analyzer detects the type of input board fitted for each input automatically and displays only the operating and programming frames applicable to that input board type. If no input board is fitted for a second input (Sensor B), Sensor B frames are not displayed.

Model	Analyzer Description	Sensor A	Sensor B
AX410	Single Input 2-Electrode Conductivity (0 to 10,000 $\mu\text{S}/\text{cm}$)	2-Electrode Conductivity	Not Applicable
AX411	Dual Input 2-Electrode Conductivity (0 to 10,000 $\mu\text{S}/\text{cm}$)	2-Electrode Conductivity	2-Electrode Conductivity
AX413	Dual Input 2-Electrode Conductivity and 4-Electrode Conductivity	2-Electrode Conductivity	4-Electrode Conductivity
AX416	Dual Input 2-Electrode Conductivity and pH/Redox(ORP)	2-Electrode Conductivity	pH/Redox(ORP)
AX418	Dual Input 2-Electrode Conductivity and Dissolved Oxygen	2-Electrode Conductivity	Dissolved Oxygen
AX430	Single Input 4-Electrode Conductivity (0 to 2,000 mS/cm)	4-Electrode Conductivity	Not Applicable
AX433	Dual Input 4-Electrode Conductivity (0 to 2,000 mS/cm)	4-Electrode Conductivity	4-Electrode Conductivity
AX436	Dual Input 4-Electrode Conductivity and pH/Redox(ORP)	4-Electrode Conductivity	pH/Redox(ORP)
AX438	Dual Input 4-Electrode Conductivity and Dissolved Oxygen	4-Electrode Conductivity	Dissolved Oxygen
AX450	Single Input 2-Electrode Conductivity (USP)	2-Electrode Conductivity	Not Applicable
AX455	Dual Input 2-Electrode Conductivity (USP)	2-Electrode Conductivity	2-Electrode Conductivity
AX456	Dual Input 2-Electrode Conductivity (USP) and pH/Redox(ORP)	2-Electrode Conductivity	pH/Redox(ORP)
AX460	Single Input pH/Redox(ORP)	pH/Redox(ORP)	Not Applicable
AX466	Dual Input pH/Redox(ORP)	pH/Redox(ORP)	pH/Redox(ORP)
AX468	Dual Input pH/Redox(ORP) and Dissolved Oxygen	pH/Redox(ORP)	Dissolved Oxygen
AX480	Single Input Dissolved Oxygen	Dissolved Oxygen	Not Applicable
AX488	Dual Input Dissolved Oxygen	Dissolved Oxygen	Dissolved Oxygen

Table 1.1 AX400 Series Analyzer Options

2 Operation

2.1 Powering Up the Analyzer

Warning. Ensure all connections are made correctly, especially to the earth stud – see Section 6.3, page 53.

1. Ensure the input sensors are connected correctly.
2. Switch on the power supply to the analyzer. A start-up screen is displayed while internal checks are performed, then the conductivity measurement readings screen (Operating Page) is displayed as conductivity measuring operation starts.

2.2 Displays and Controls

The display comprises two rows of 4½ digit, 7-segment digital displays, which show the actual values of the measured parameters and alarm set points, and a 6-character dot matrix display showing the associated units. The lower display line is a 16-character dot matrix display showing the programming information.

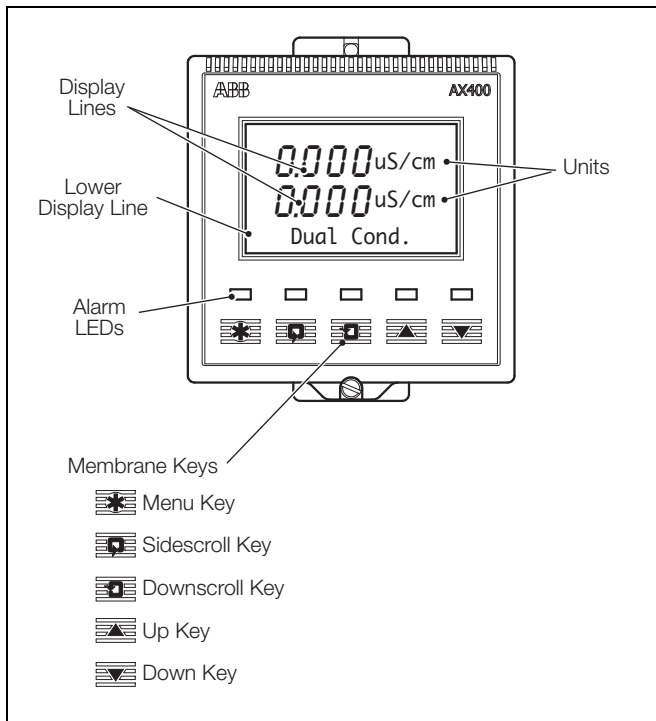

Fig. 2.1 Location of Controls and Displays

2.2.1 Membrane Key Functions – Fig. 2.2

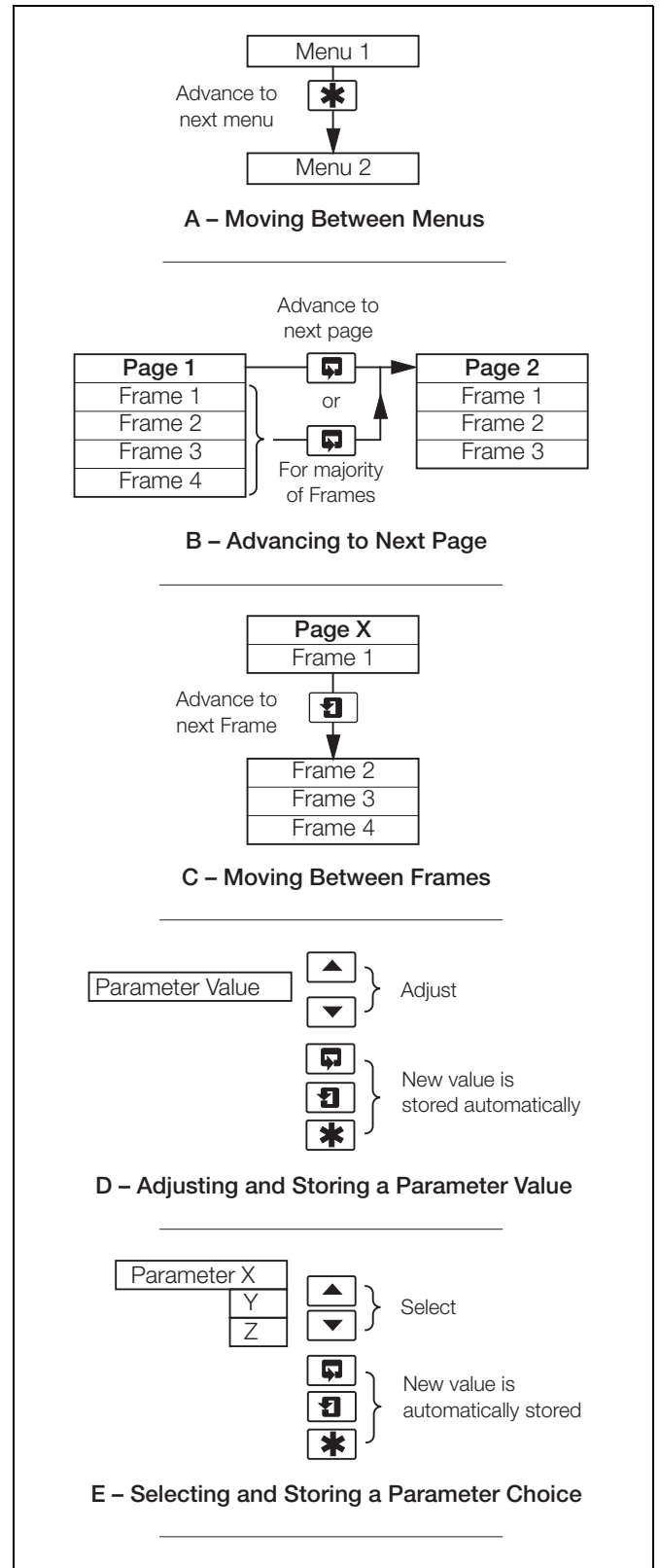

Fig. 2.2 Membrane Key Functions

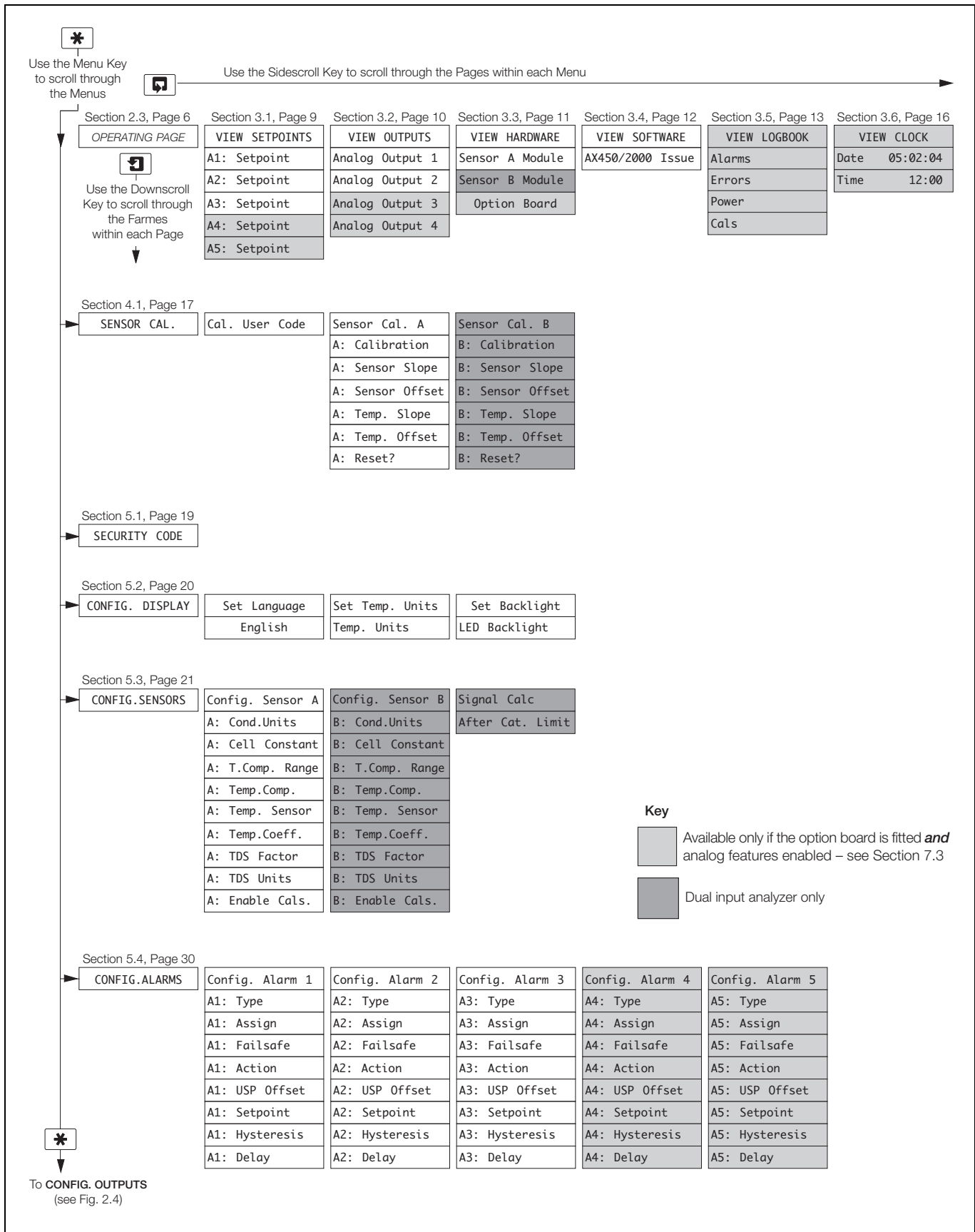

Fig. 2.3 Overall Programming Chart

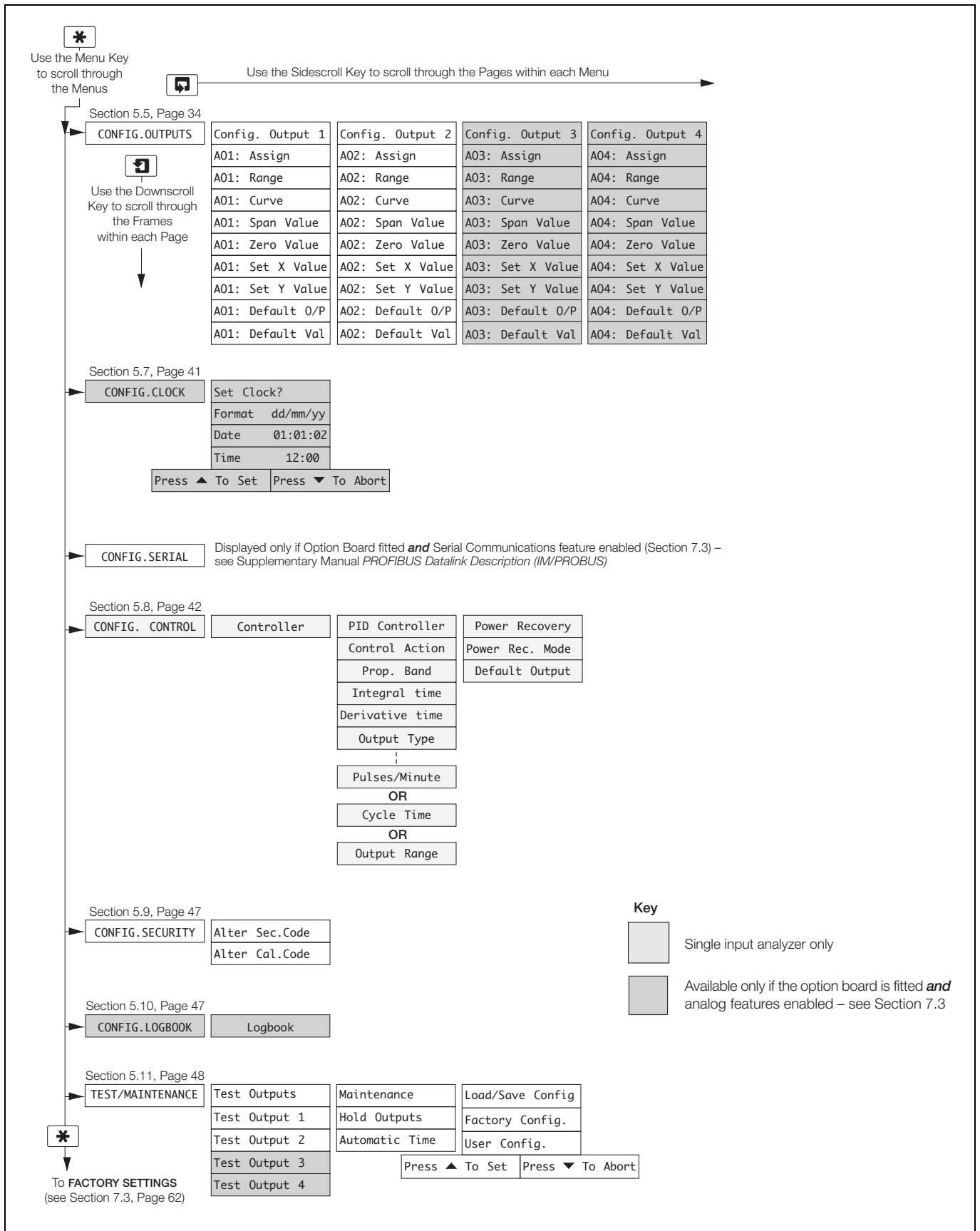
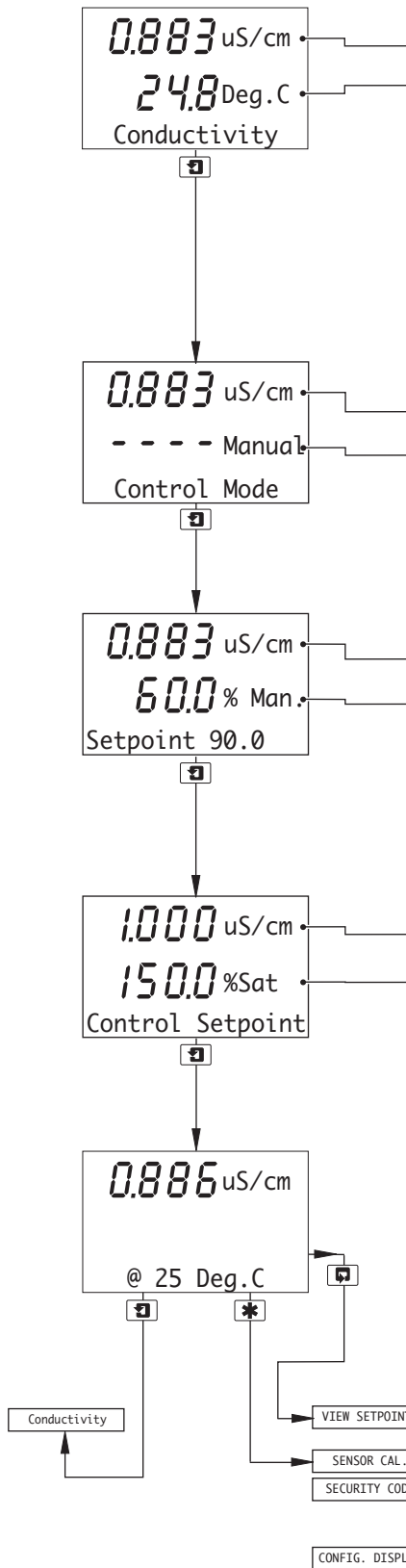

Fig. 2.4 Overall Programming Chart (Continued)

2.3 Operating Page

2.3.1 Single Input Conductivity



Measured Values

Conductivity.

Temperature.

Notes.

- The displayed conductivity and temperature readings are the actual measured values of the sample.
- AX450 analyzers only – if **A: Cond.Units** is set to **USP645** (Section 5.3), the displayed conductivity reading is the uncompensated conductivity value of the sample, i.e. its value at the displayed temperature.

Control Mode

Conductivity value.

Control mode.

Use the ▲ and ▼ keys to switch between manual (**Manual**) and automatic (**Auto**) control.

Note. Displayed only if **Controller** is set to **PID** – see Section 5.7, page 41.

Control Output

Conductivity value.

Control output (%), manual (**Man**) or automatic (**Auto**).

When **Control Mode** is set to **Manual** (see above), use the ▲ and ▼ keys to adjust the control output between 0 and 100%.

Note. Displayed only if **Controller** is set to **PID** – see Section 5.7, page 41.

Control Set Point

Conductivity value.

Control set point.

Use the ▲ and ▼ keys to adjust the control set point between 0 and 250% conductivity.

Note. Displayed only if **Controller** is set to **PID** – see Section 5.7, page 41

Temperature Compensated Conductivity Value – AX450 Analyzers Only

Notes.

- This frame is displayed only if **A: Cond.Units** is set to **USP645** – see Section 5.3, page 21.
- The displayed reading is the temperature compensated conductivity value i.e. the value it would be at a sample temperature of 25°C (77°F).

VIEW SETPOINTS See Section 3.1, page 9.

SENSOR CAL. **Enable Cals.** set to **Yes** (Section 5.3) – see Section 4.1, page 17.

SECURITY CODE **Enable Cals.** set to **No** (Section 5.3) **and Alter Sec. Code** not set to zero (Section 5.9) – see Section 5.1, page 19.

CONFIG. DISPLAY **Enable Cals.** set to **No** (Section 5.3) **and Alter Sec. Code** set to zero (Section 5.9) – see Section 5.2, page 20.

2.3.2 Dual Input Conductivity

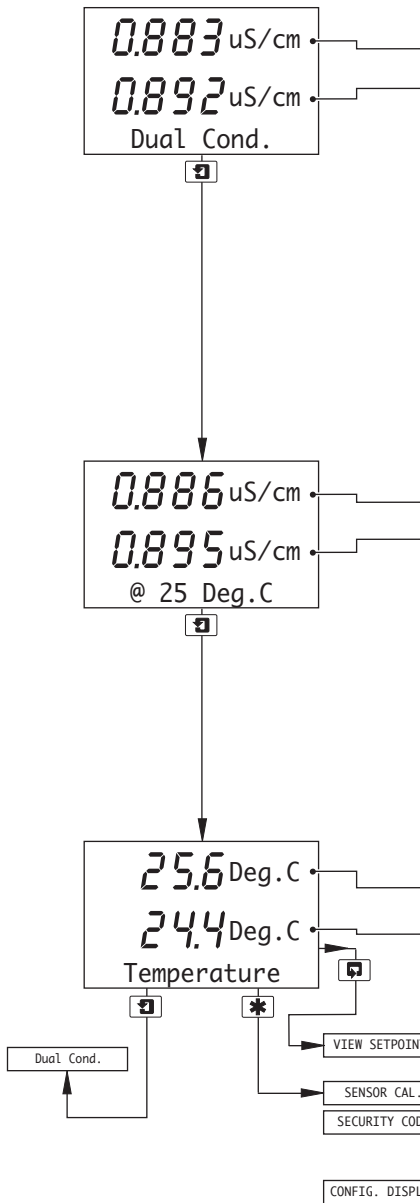

Measured Conductivity

Sensor A.
 Sensor B.

Notes.

- **Dual Cond.** is displayed only if **Signal Calc.** is set to **No Calculation** – see Section 5.3, page 21. See below for an explanation of calculations.
- The displayed conductivity readings are the actual values of the sample.
- AX455 analyzers only – If **Cond.Units** for a sensor is set to **USP645** (Section 5.3), the displayed conductivity reading for that sensor is the uncompensated conductivity value of the sample, i.e. its value at its measured temperature (see below).

Temperature Compensated Conductivity – AX455 Analyzers Only

Sensor A.
 Sensor B.

Notes.

- This frame is displayed only if **Cond.Units** for either or both sensors is set to **USP645** – see Section 5.3, page 21.
- If **Cond.Units** for a sensor is set to **USP645** (Section 5.3), the displayed conductivity reading for that sensor is the temperature compensated value, i.e. the value it would be at a sample temperature of 25°C (77°F).

Measured Temperature

Sensor A.
 Sensor B.

Note. The displayed temperature readings are the actual values of the sample.

See Section 3.1, page 9.

Enable Cals. set to **Yes** (Section 5.3) – see Section 4.1, page 17.

Enable Cals. set to **No** (Section 5.3) **and Alter Sec. Code** not set to zero (Section 5.9) – see Section 5.1, page 19.

Enable Cals. set to **No** (Section 5.3) **and Alter Sec. Code** set to zero (Section 5.9) – see Section 5.2, page 20.

Calculations

A range of computed dual conductivity readings can be displayed, each showing the result of a calculation performed by the analyzer. In each case, the type of calculation is shown on the lower display line, followed by the result of the calculation.

Calculations performed are:

$$\text{Difference} = A - B$$

$$\% \text{ Rejection} = (1 - B/A) \times 100$$

$$\% \text{ Passage} = B/A \times 100$$

$$\text{Ratio} = A/B$$

$$\text{Inferred pH} = \text{Uses an algorithm to calculate the pH value of the solution, inferred from its conductivity, in the range 7.00 to 11.00 pH. See Appendix A.3 on page 75 for further information on inferred pH.}$$

Note. If the analyzer is used with a cation resin column, Sensor A must be installed before the column and Sensor B after the column for the calculations, especially inferred pH, to be correct.

3 Operator Views

3.1 View Set Points

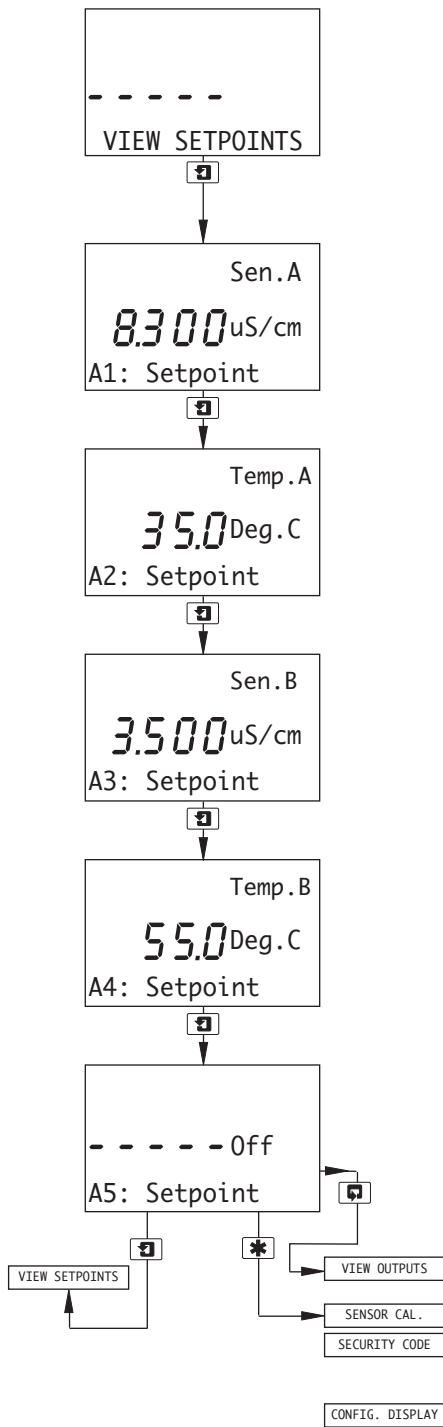

View Set Points

This page shows alarm set points. The value of each of the set points is shown, together with the name of the parameter it's assigned to.

Alarm assignments, set point values and relay/LED actions are programmable – see Section 5.4, page 30. Those shown in the following frames are examples only.

Sensor A (Conductivity), Alarm 1 Set Point

Sen. A
 8.300 uS/cm
 A1: Setpoint

Sensor A (Temperature), Alarm 2 Set Point

Temp. A
 35.0 Deg. C
 A2: Setpoint

Sensor B (Conductivity), Alarm 3 Set Point – Dual input analyzers only

Sen. B
 3.500 uS/cm
 A3: Setpoint

Sensor B (Temperature), Alarm 4 Set Point – Dual input analyzers only

Temp. B
 55.0 Deg. C
 A4: Setpoint

Note. Alarm 4 available only if option board fitted *and* analog features enabled – see Section 7.3, page 62.

Alarm 5 Set Point

--- Off
 A5: Setpoint

Note. Alarm 5 available only if option board fitted *and* analog features enabled – see Section 7.3, page 62.

See Section 3.2, page 10.

Enable Cals. set to **Yes** (Section 5.3) – see Section 4.1, page 17.

Enable Cals. set to **No** (Section 5.3) *and* **Alter Sec. Code** not set to zero (Section 5.9) – see Section 5.1, page 19.

Enable Cals. set to **No** (Section 5.3) *and* **Alter Sec. Code** set to zero (Section 5.9) – see Section 5.2, page 20.

3.2 View Outputs

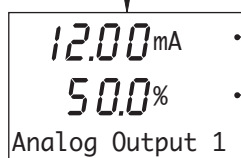
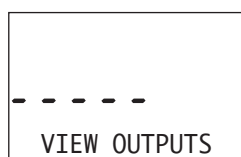

Theoretical Analog Output

There are up to four analog outputs, each showing information for one sensor.

Note. Analog outputs 3 and 4 available only if option board fitted and analog features enabled – see Section 7.3, page 62.

Live current output value being retransmitted.

Current output shown as a percentage of full scale for the output range set in **CONFIG. OUPUTS** – see Section 5.5, page 34.

VIEW HARDWARE

See Section 3.3, page 11.

SENSOR CAL.

Enable Cals. set to **Yes** (Section 5.3) – see Section 4.1, page 17.

SECURITY CODE

Enable Cals. set to **No** (Section 5.3) **and Alter Sec. Code** not set to zero (Section 5.9) – see Section 5.1, page 19.

CONFIG. DISPLAY

Enable Cals. set to **No** (Section 5.3) **and Alter Sec. Code** set to zero (Section 5.9) – see Section 5.2, page 20.

Analog Output 2

Advance to analog output 2 (and outputs 3 and 4 if option board fitted **and** analog features enabled – see Section 7.3, page 62).

3.3 View Hardware

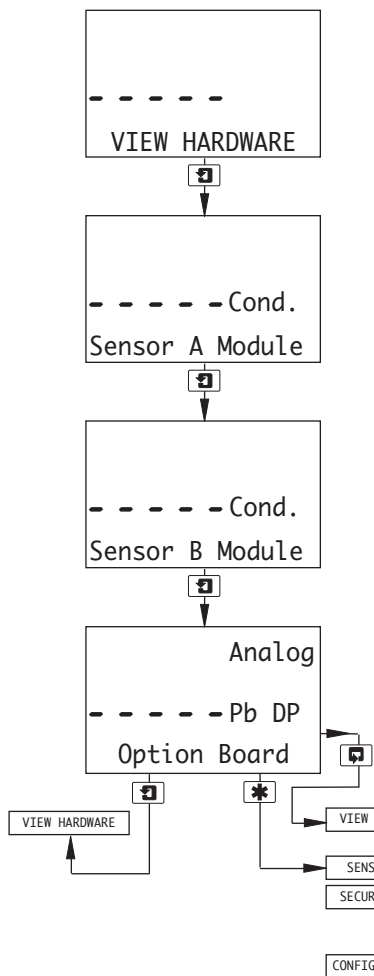

Sensor A Module

Shows the type of input board fitted to the analyzer for the Sensor A input.
 Cond. – 2-Electrode Conductivity

Sensor B Module – Dual input analyzers only

Shows the type of input board fitted to the analyzer for the Sensor B input.

Option Board

Note. Displayed only if the option board is fitted.

Displays the optional features enabled in the **Factory Settings** page – see Section 7.3, page 62.

VIEW SOFTWARE See Section 3.4, page 12.

SENSOR CAL. **Enable Cals.** set to **Yes** (Section 5.3) – see Section 4.1, page 17.

SECURITY CODE **Enable Cals.** set to **No** (Section 5.3) **and Alter Sec. Code** not set to zero (Section 5.9) – see Section 5.1, page 19.

CONFIG. DISPLAY **Enable Cals.** set to **No** (Section 5.3) **and Alter Sec. Code** set to zero (Section 5.9) – see Section 5.2, page 20.

3.4 View Software

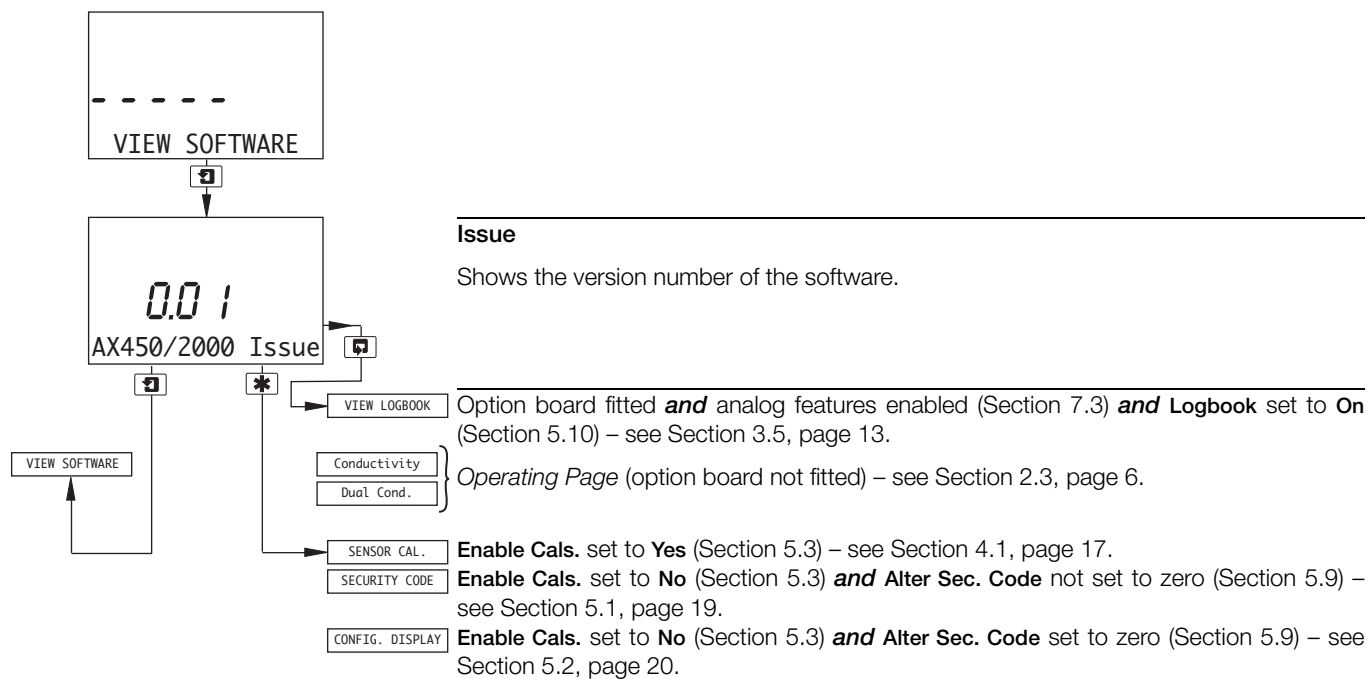

3.5 View Logbook

Note. The View Logbook function is available only if the option board is fitted **and** analog features enabled (Section 7.3) **and** Logbook is set to On (Section 5.10).

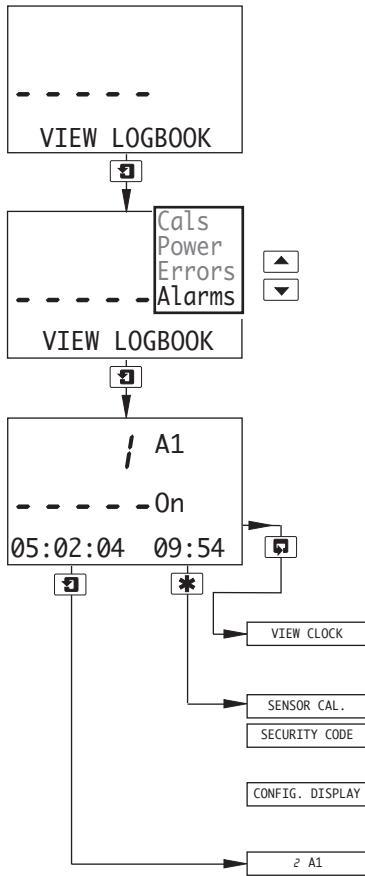

The logbook stores data entries for alarm events, sensor errors, power failures and sensor calibrations.

View Logbook

Use the ▲ and ▼ keys to access the **Alarms** logbook.

Note. If no entries are stored in the **Alarms** logbook, the display shows **No More Entries**.

Alarms

The Alarms logbook contains up to 10 entries (entry 1 is the most recent), each comprising an alarm number, alarm state (On or Off), and the date/time of the occurrence.

Option board fitted **and** analog features enabled (Section 7.3) – see Section 3.6, page 16.

Enable Cals. set to **Yes** (Section 5.3) – see Section 4.1, page 17.

Enable Cals. set to **No** (Section 5.3) **and** **Alter Sec. Code** not set to zero (Section 5.9) – see Section 5.1, page 19.

Enable Cals. set to **No** (Section 5.3) **and** **Alter Sec. Code** set to zero (Section 5.9) – see Section 5.2, page 20.

Advance to entries 2 to 10.

Note. If no more entries are stored, the display shows **No More Entries**.

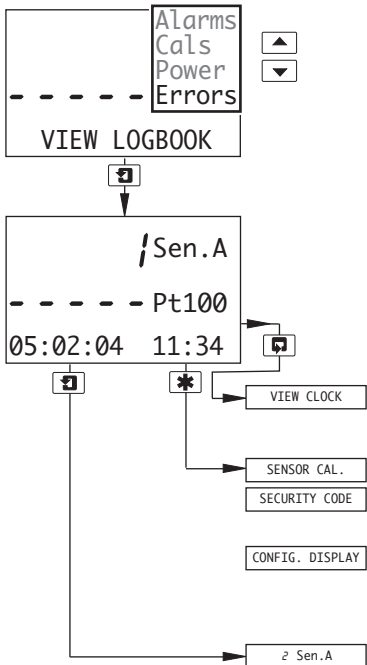

View Logbook

Use the ▲ and ▼ keys to access the **Errors** logbook.

Note. If no entries are stored in the **Errors** logbook, the display shows **No More Entries**.

Errors

The **Errors** logbook contains up to 5 entries (entry 1 is the most recent), each comprising the sensor letter, error number and the date/time of the occurrence.

Option board fitted **and** analog features enabled (Section 7.3) – see Section 3.6, page 16.

Enable Cals. set to **Yes** (Section 5.3) – see Section 4.1, page 17.

Enable Cals. set to **No** (Section 5.3) **and Alter Sec. Code** not set to zero (Section 5.9) – see Section 5.1, page 19.

Enable Cals. set to **No** (Section 5.3) **and Alter Sec. Code** set to zero (Section 5.9) – see Section 5.2, page 20.

Advance to entries 2 to 5.

Note. If no more entries are stored, the display shows **No More Entries**.

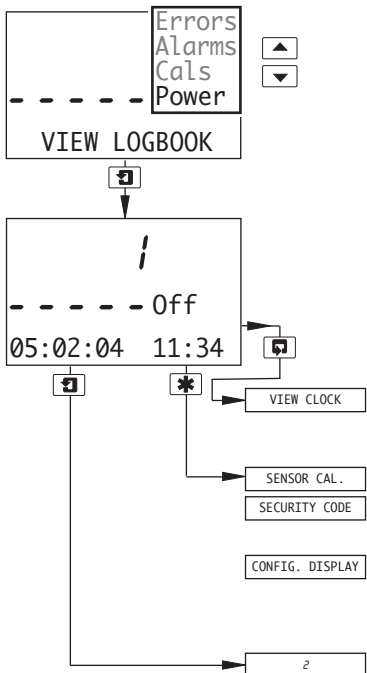

View Logbook

Use the ▲ and ▼ keys to access the **Power** logbook.

Note. If no entries are stored in the **Power** logbook, the display shows **No More Entries**.

Power

The **Power** logbook contains up to 2 entries (entry 1 is the most recent), each comprising the power state (On or Off) and the date/time of the occurrence.

Option board fitted **and** analog features enabled (Section 7.3) – see Section 3.6, page 16.

Enable Cals. set to **Yes** (Section 5.3) – see Section 4.1, page 17.

Enable Cals. set to **No** (Section 5.3) **and Alter Sec. Code** not set to zero (Section 5.9) – see Section 5.1, page 19.

Enable Cals. set to **No** (Section 5.3) **and Alter Sec. Code** set to zero (Section 5.9) – see Section 5.2, page 20.

Advance to entry 2.

Note. If no more entries are stored, the display shows **No More Entries**.

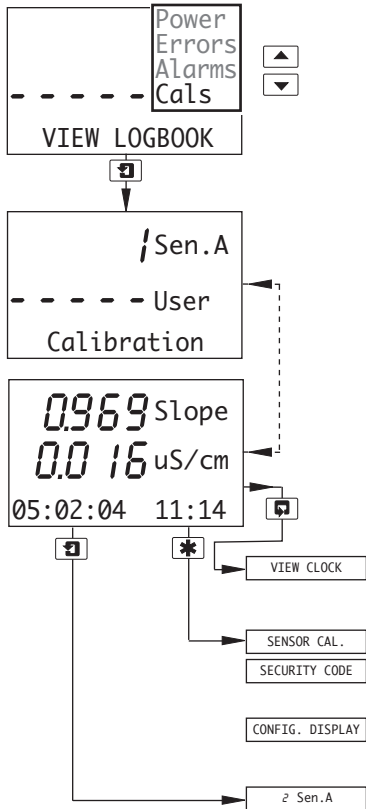

View Logbook

Use the ▲ and ▼ keys to access the **Cals** logbook.

Note. If no entries are stored in the **Cals** logbook, the display shows **No More Entries**.

Calibration

The **Cals** logbook contains up to 5 entries (entry 1 is the most recent), each comprising 2 frames. Frame 1 contains the entry number and sensor letter and shows User to indicate a user performed calibration.

Frame 2 contains either the sensor % slope and sensor offset values (for a conductivity calibration), or the temperature % slope and temperature offset values (for a temperature calibration), together with the date/time of the calibration.

Note. If no more entries are stored, the display shows **No More Entries**.

Option board fitted **and** analog features enabled (Section 7.3) – see Section 3.6, page 16.

Enable Cals. set to **Yes** (Section 5.3) – see Section 4.1, page 17.

Enable Cals. set to **No** (Section 5.3) **and Alter Sec. Code** not set to zero (Section 5.9) – see Section 5.1, page 19.

Enable Cals. set to **No** (Section 5.3) **and Alter Sec. Code** set to zero (Section 5.9) – see Section 5.2, page 20.

Advance to entries 2 to 5.

Note. If no more entries are stored, the display shows **No More Entries**.

3.6 View Clock

Note. The View Clock function is available only if the option board is fitted **and** analog features enabled – see Section 7.3, page 62.

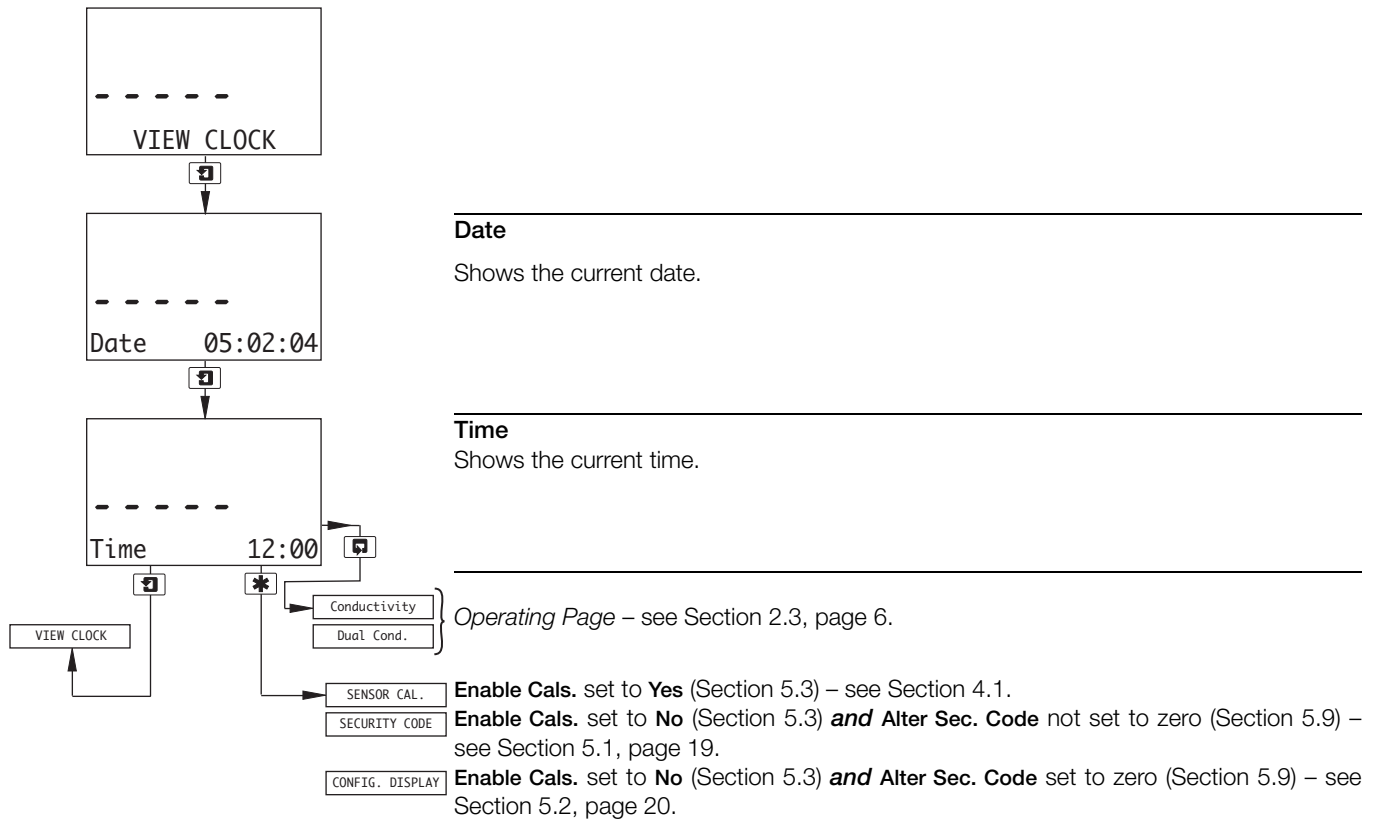

4 Setup

4.1 Sensor Calibration

Note.

- Sensor calibration is not usually required as the cell constant 'K' assigned to a cell is sufficiently accurate for most applications.
- TB2 cells are equipped with 2-wire temperature compensators therefore temperature errors can be expected in applications where the length of the connecting cable exceeds 10m. Carry out an in-situ temperature calibration to remove these errors.

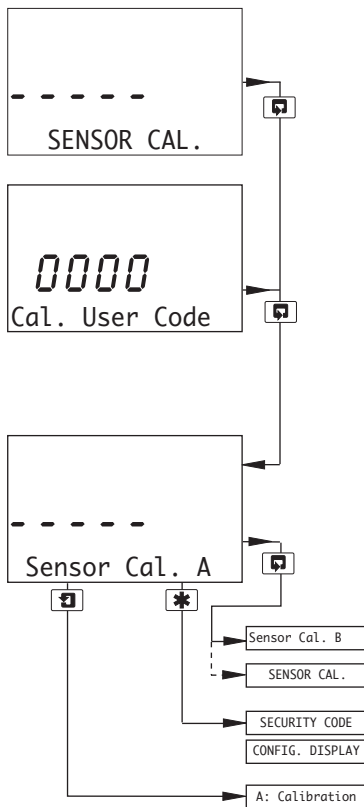

Sensor Calibration

Note. Applicable only if **Enable Cals.** is set to **Yes** – see Section 5.3, page 21.

Sensor Calibration Security Code

Note. This frame is displayed only if **Alter Cal. Code** is not set to zero – see Section 5.9, page 47.

Enter the required code number (between 0000 and 19999) to gain access to the sensor calibration pages. If an incorrect value is entered, access to the calibration pages is prevented and the display reverts to the **SENSOR CAL.** frame.

Calibrate Sensor A

Sensor B calibration (dual input analyzers only) is identical to Sensor A calibration.

Single input analyzers only – return to main menu.

Alter Sec. Code not set to zero (Section 5.9) – see Section 5.1, page 19.

Alter Sec. Code set to zero (Section 5.9) – see Section 5.2, page 20.

Continued below.

Edit or Reset Calibration

Select **Edit** to manually adjust the Slope and Offset values of the process and temperature sensors.

Select **Reset** to reset the sensor calibration data to the standard default settings:

Sensor and Temperature Slope = 1.000

Sensor and Temperature Offset = 0.0

Edit selected – continued on next page.

Reset selected – continued on next page.

A: Calibration
 set to Edit

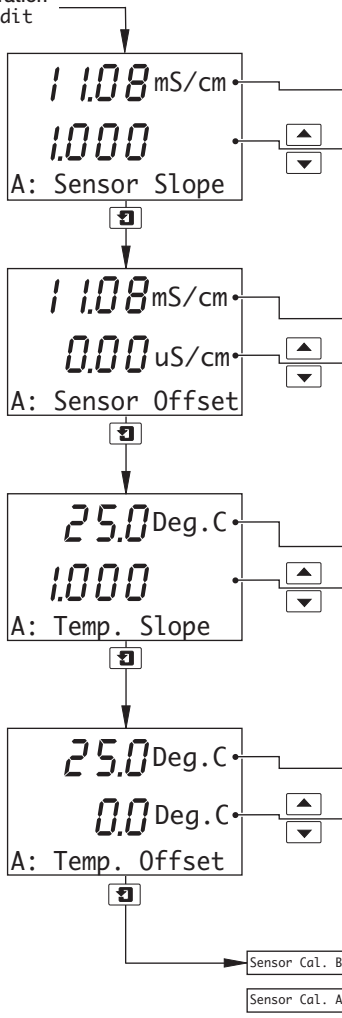

Sensor Slope

Measured conductivity value.

Sensor slope value.

Use the and keys to adjust the sensor slope value within the range 0.200 to 5.000 until the measured conductivity value is correct.

Sensor Offset

Measured conductivity value.

Sensor offset value.

Use the and keys to adjust the sensor offset value within the range -20.00 to 20.00 until the measured conductivity value is correct.

Temperature Slope

Measured temperature value.

Temperature slope value.

Use the and keys to adjust the temperature slope value within the range 0.200 to 1.500 until the measured temperature value is correct.

Temperature Offset

Measured temperature value.

Temperature offset value.

Use the and keys to adjust the temperature offset value within the range -40.0 to 40.0°C (-40.0 to 104.0°F) until the measured temperature value is correct.

Sensor B calibration (dual input analyzers only) is identical to Sensor A calibration.

Sensor Cal. A Single input analyzers only – return to top of page.

A: Calibration
 set to Reset

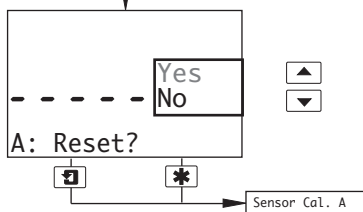

Reset Calibration

Select **Yes** and press to reset the calibration data.

Select **No** and press to abort.

Return to top of page.

5 Programming

5.1 Security Code

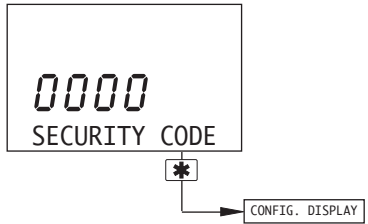

Note. This frame is displayed only if **Alter Sec. Code** is not set to zero – see Section 5.9, page 47.

Enter the required code number (between 0000 and 19999) to gain access to the configuration pages. If an incorrect value is entered, access to the configuration pages is prevented and the display reverts to the Operating Page – see Section 2.3, page 6.

See Section 5.2, page 20.

5.2 Configure Display

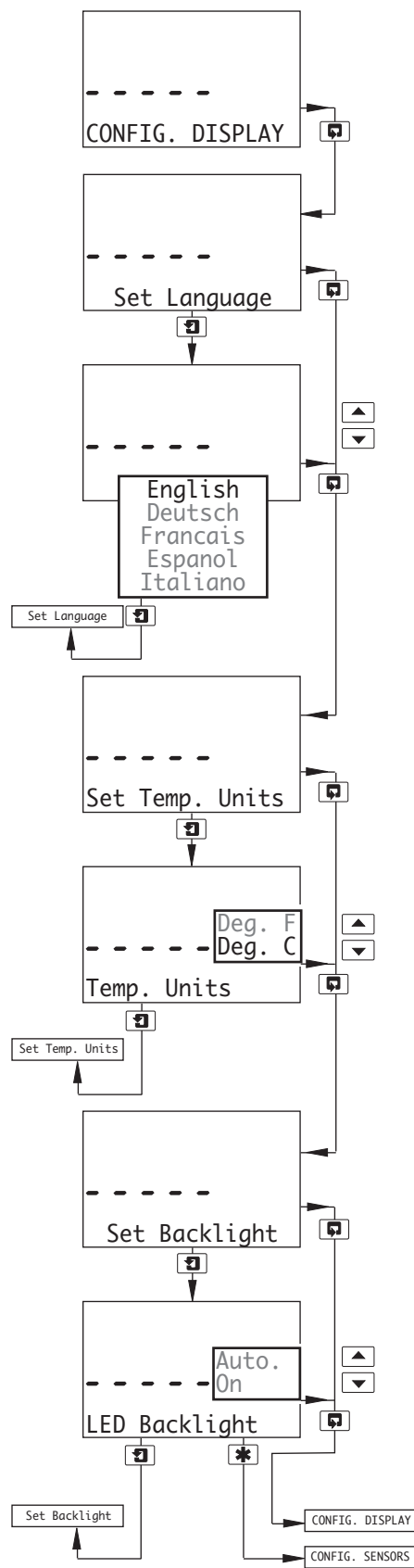

Set Language

Sets the language to be used on all displays.

Language

Use the ▲ and ▼ keys to select the required language.

Set Temperature Units

Temperature Units

Use the ▲ and ▼ keys to select the sample temperature display units.

Set Up Display Backlight

Backlight

Use the ▲ and ▼ keys to select the required backlight option:

- Auto.** – Backlight comes on at each button press and switches off one minute after the last button press.
- On** – Backlight is always on.

CONFIG. DISPLAY Return to main menu.

CONFIG. SENSORS See Section 5.3, page 21.

5.3 Configure Sensors

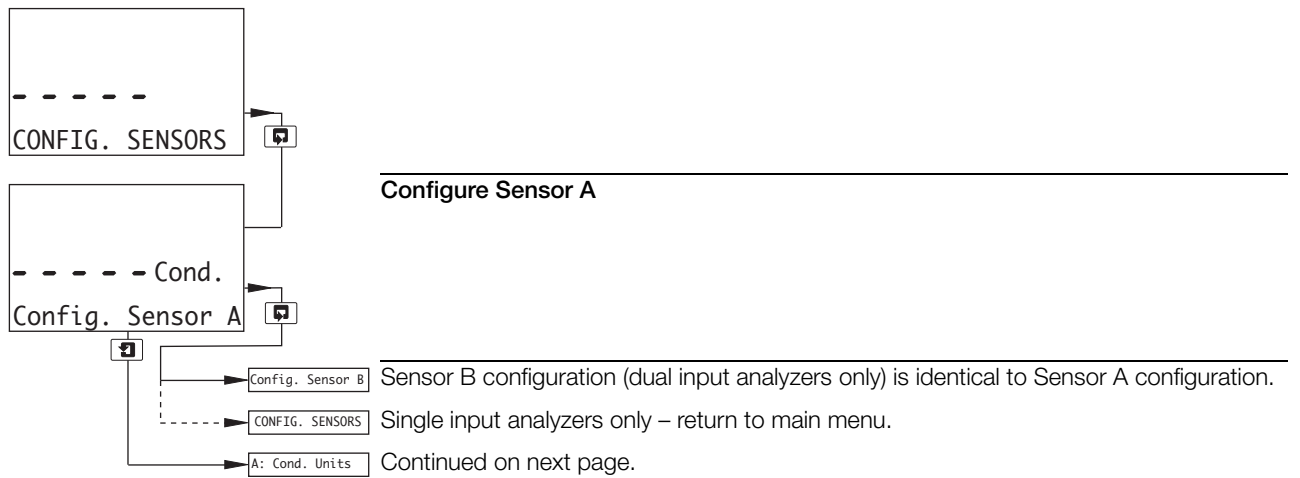

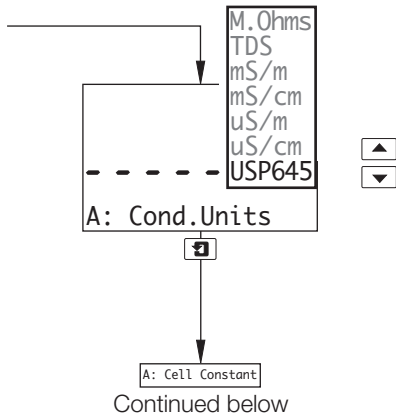

Conductivity Units

Units can be programmed to suit the range and application. Select the required units, ensuring the range does not exceed the display limit of 10,000 $\mu\text{S cm}^{-1}$:

- M. Ohms – Megohms-cm
 - TDS – Total Dissolved Solids (see Table 5.1)
 - mS/m – MilliSiemens m^{-1} ($0.1\mu\text{S cm}^{-1}$)
 - mS/cm – MilliSiemens cm^{-1} ($1000\mu\text{S cm}^{-1}$)
 - uS/m – MicroSiemens m^{-1} ($100\mu\text{S cm}^{-1}$)
 - uS/cm – MicroSiemens cm^{-1}
 - USP645 – MicroSiemens cm^{-1}
- } (see Table 5.2)

Note. USP645 available only on AX450 and AX455 analyzers.

Conductivity Cell Constant (K)	Conductivity Measuring Range ($\mu\text{S cm}^{-1}$)	Effective TDS Range (ppm, mg/kg and mg/l)				
		TDS Factor (examples)				
		0.40	0.50	0.60	0.70	0.80
0.1	0 to 1,000	0 to 400	0 to 500	0 to 600	0 to 700	0 to 800
1.0	0 to 10,000	0 to 4,000	0 to 5,000	0 to 6,000	0 to 7,000	0 to 8,000

Table 5.1 Range Limits for Different Cell Constants (K)

Conductivity Cell Constant (K)	Conductivity Measuring Range
0.01	0 to 100.0 $\mu\text{S cm}^{-1}$ 0 to 10,000 $\mu\text{S m}^{-1}$
0.05	0 to 500.0 $\mu\text{S cm}^{-1}$ 0 to 10,000 $\mu\text{S m}^{-1}$
0.10	0 to 1,000 $\mu\text{S cm}^{-1}$ 0 to 10,000 $\mu\text{S m}^{-1}$ 0 to 100.0 mS m^{-1}
1.00	0 to 10,000 $\mu\text{S cm}^{-1}$ 0 to 10,000 $\mu\text{S m}^{-1}$ 0 to 10 mS cm^{-1} 0 to 1,000 mS m^{-1}

Table 5.2 Conductivity Range Limits for Different Cell Constants (K)

Cell Constant

Enter the cell constant for the type of measuring cell used – see the relevant cell manual.

Note. If A: Cond Units is set to USP645 (AX450 and AX455 analyzers only), the maximum cell constant is 0.10.

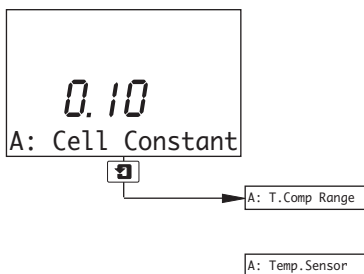

AX410 and AX411 analyzers or A: Cond Units not set to USP645 (AX450 and AX455 analyzers only) – continued on next page.

A: Cond Units set to USP645 (AX450 and AX455 analyzers only) – continued on page 26.

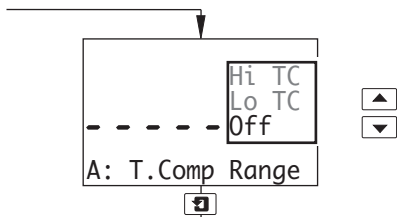

Temperature Compensation Range

Select a temperature compensation range to suit the sample temperature:

Off – Raw conductivity measurement without temperature compensation.

Examples

■ Water for injection (WFI) for US Pharmacopoeia (USP) applications.

■ Purified water for USP applications.

Lo TC – Temperature compensation for sample temperatures in the range 0 to 100°C (0 to 212°F). This setting is suitable for the majority of applications.

Hi TC – Temperature compensation for sample temperatures in the range 0 to 200°C (0 to 392°F). This setting is used only for special high temperature applications.

- Lo TC → A: Temp.Comp Continued on next page.
- Hi TC → A: Temp.Comp Continued on page 25.
- Off → A: Temp.Sensor Continued on page 26.

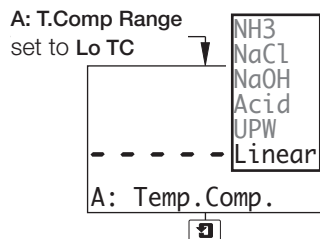

Low Range Temperature Compensation

Select the type of low range (0 to 100°C [32 to 212°F]) temperature compensation required:

Linear – Linear temperature compensation based on a manually entered temperature coefficient (see Appendix A.1, page 73) – see **Temp.Coeff.** frame on page 26.

Example

- Non-standard applications.

UPW* – Temperature compensation based on the temperature coefficient of pure water. Source data is based on International Standard IEC 60746-3.

Also enables manual entry of a temperature coefficient (see **Temp.Coeff.** frame on page 26) for applications where pure water contains an unknown impurity; in which case the temperature coefficient must be calculated – see Appendix A.1.1, page 74.

Acid** – Temperature compensation based on the temperature coefficient of pure water containing trace acids.

Examples

- Cation exchanger in-bed and outlet applications.
- Degassed cation/conductivity applications.

NaOH*** – Temperature compensation based on the temperature coefficient of pure water containing trace caustic.

Example

- Inferred pH in caustic-dosed waters applications.

NaCl* – Temperature compensation based on the temperature coefficient of pure water containing trace salts.

Examples

- General monitoring applications.
- Mixed-bed exchanger applications.
- Final polisher effluent applications.
- Cation exchanger inlet applications.
- Anion exchanger in-bed and outlet applications.
- Reverse osmosis applications.

NH3** – Temperature compensation based on the temperature coefficient of pure water containing trace ammonia.

Examples

- Ammonia-treated make-up and boiler feed water applications.
- Condenser sampling applications.
- Hot well sampling applications.
- Before-cation column applications.
- Inferred pH in ammonia-dosed waters applications.

* Applicable only on conductivities up to 10µS cm⁻¹

** Applicable only on conductivities up to 25µS cm⁻¹

*** Applicable only on conductivities up to 100µS cm⁻¹

A: Temp.Sensor

Continued on page 26.

A: T.Comp Range
set to Hi TC

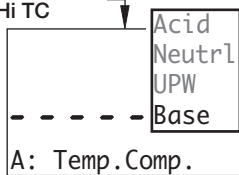

High Range Temperature Compensation

Select the type of high range (0 to 200°C [32 to 392°F]) temperature compensation required:

- Base*** – Temperature compensation based on the temperature coefficient of pure water containing trace alkalis.
- UPW*** – Temperature compensation based on the temperature coefficient of pure water. Source data is based on International Standard IEC 60746-3.
Also enables manual entry of a temperature coefficient (see **Temp.Coeff.** frame on page 26) for applications where pure water contains an unknown impurity; in which case the temperature coefficient must be calculated – see Appendix A.1.1, page 74.
- NeutrL*** – Temperature compensation based on the temperature coefficient of pure water containing trace neutral salts.
- Acid*** – Temperature compensation based on the temperature coefficient of pure water containing trace acids.

Examples

- Cation exchanger in-bed and outlet applications.
- Degassed cation/conductivity applications.

* Applicable only on conductivities up to 10µS cm⁻¹

A: Temp.Sensor

Continued on next page.

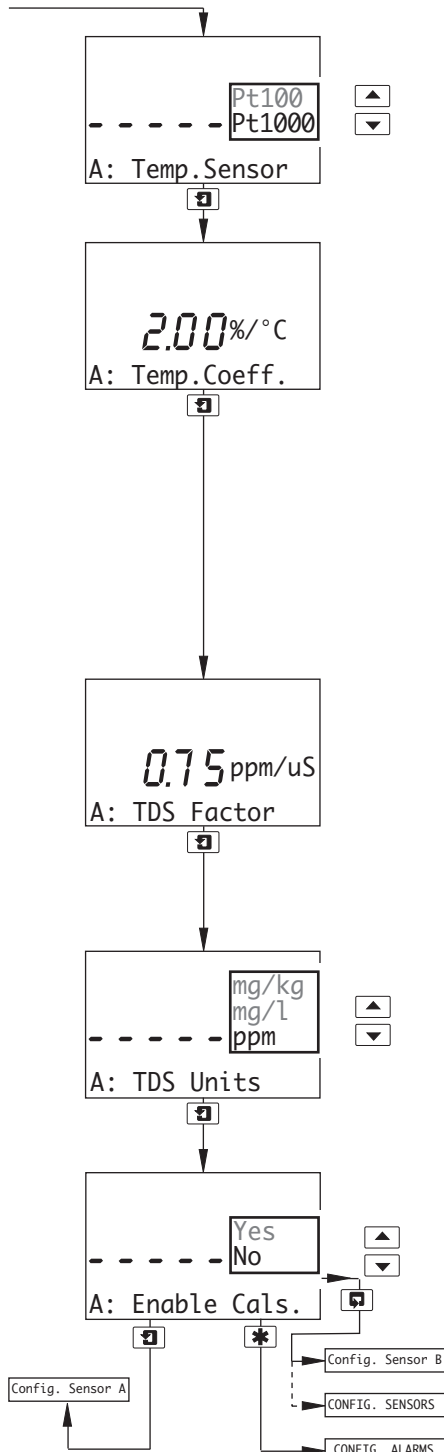

Temperature Sensor

Select the type of temperature sensor used, Pt100 or Pt1000.

Temperature Coefficient

Notes.

- Displayed only if **T.Comp Range** is set to **Lo TC** and **Temp.Comp.** is set to **Linear** or **UPW** or **T.Comp Range** is set to **Hi TC** and **Temp.Comp.** is set to **UPW** – see pages 23 to 25.
- If **A: Cond Units** is set to **USP645** (AX450 and AX455 analyzers only – see page 22), the temperature coefficient is fixed automatically at 2.00%/°C.

Enter the temperature coefficient ($\alpha \times 100$) of the solution (0.01 to 5.0%/°C). If unknown, the temperature coefficient (α) of the solution must be calculated – see Appendix A.1.1, page 74.

If the value has not yet been calculated, set it to 2%/°C provisionally.

TDS Factor

Note. Displayed only if **A: Cond.Units** is set to TDS – see page 22.

The TDS factor must be programmed to suit the particular application – see Appendix A.2, page 74.

Enter the required TDS factor between 0.4 and 0.8.

For salinity applications, set the TDS factor to 0.6.

TDS Units

Note. Displayed only if **A: Cond.Units** is set to TDS – see page 22.

Select the TDS units (ppm, mg/l or mg/kg).

Enable Calibration

Select **Yes** to enable sensor calibration – see Section 4.1, page 17.

If **No** is selected the calibration menu, pages and frames for the relevant sensor are not displayed.

Config. Sensor B Sensor B configuration (dual input analyzers only) is identical to Sensor A configuration.

CONFIG. SENSORS Single input analyzers only – return to main menu.

CONFIG. ALARMS See Section 5.4.

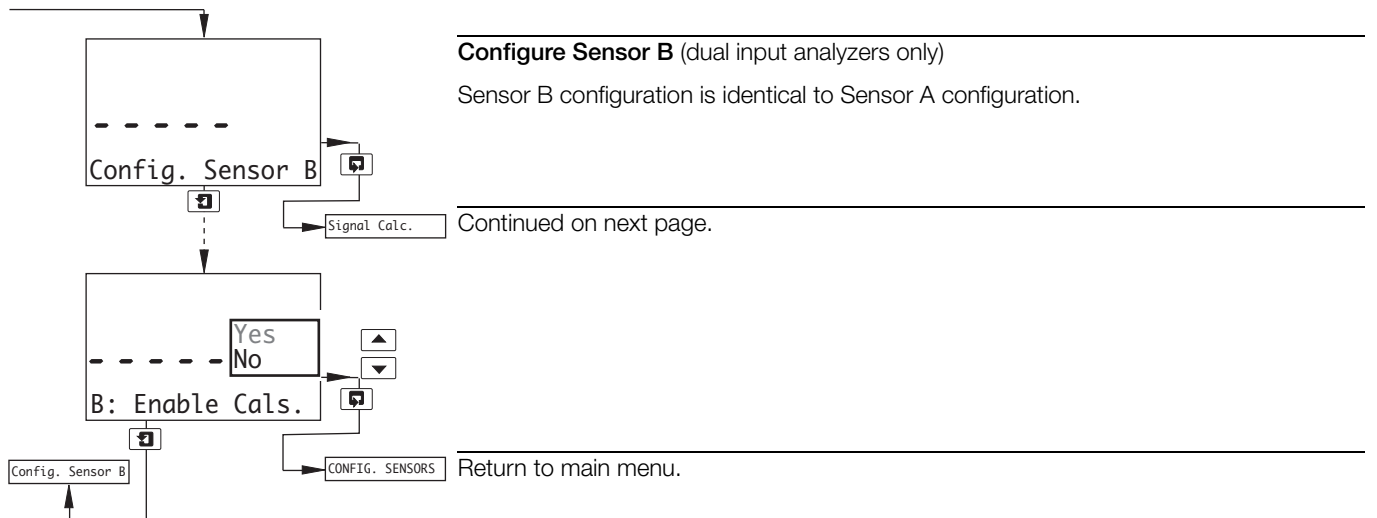

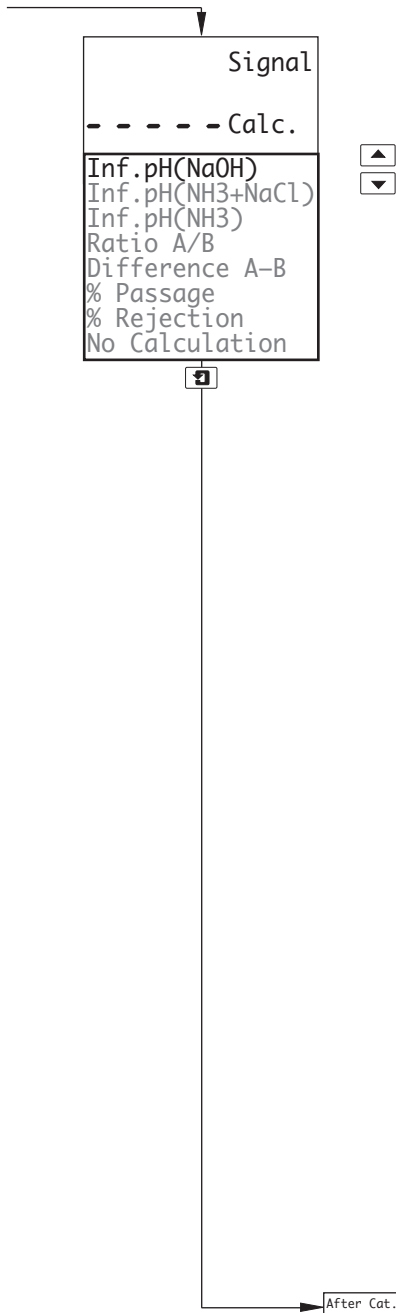

Signal Calculation (dual input analyzers only)

Notes.

- If the units selected for **A: Cond Units** and **B: Cond Units** are not identical (page 22), no calculations are performed and **No Calculation** and **Dissimilar Units** are displayed alternately on the lower display line.
- For correct inferred pH calculation, Sensor A **must** be installed **before** the cation column and Sensor B **after**.
- Refer to Appendix A.3 for further information on inferred pH.

Calculations are performed using the inputs from both sensors. Select the required calculation from the following options:

Inf. pH(NaOH) – Calculates a pH value in the range 7.00 to 11.00 pH based on the type of chemical dosing and the conductivity readings.

Note. **Inf.pH(NaOH)** is available only if:

A: Cond Units and B: Cond Units are set to **uS/cm** (page 22)

and

A: T.Comp Range and B: T.Comp Range are set to **Lo TC** (page 23)

and

A: Temp. Comp. is set to **NaOH and B: Temp. Comp** is set to **Acid** (pages 24 and 25).

Inf. pH(NH3+NaCl) – } Calculates a pH value in the range 7.00 to 10.00 pH based
Inf. pH(NH3) – } on the type of chemical dosing and the conductivity readings.

Note. **Inf.pH(NH3+NaCl)** and **Inf.pH(NH3)** are available only if:

A: Cond Units and B: Cond Units are set to **uS/cm** (page 22)

and

A: T.Comp Range and B: T.Comp Range are set to **Lo TC** (page 23)

and

A: Temp. Comp. is set to **NH3 and B: Temp. Comp** is set to **Acid** (pages 24 and 25).

Ratio A/B – Calculates the ratio of the two conductivity inputs.

Difference A-B – Calculates the difference between the two conductivity inputs.

% Passage – Calculates the amount of conductivity as a percentage that passes through the cation exchange unit.

% Rejection – Calculates the amount of conductivity as a percentage that is absorbed in the cation exchange unit.

No Calculation – No calculation is performed and the conductivity readings are displayed directly.

After Cat. Limit Continued on next page.

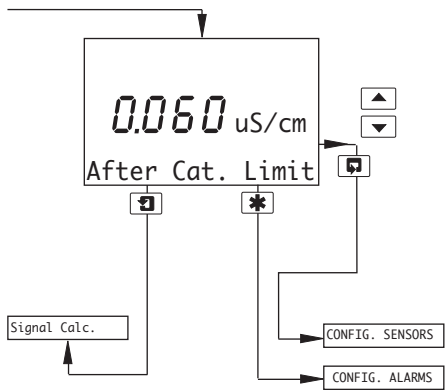

After-cation Limit

Note. Displayed only if **Signal Calc.** is set to **Inf.pH(NH3)**, **Inf.pH(NH3+NaCl)** or **Inf.pH(NaOH)**.

Set the required after-cation conductivity limit, between:

- 0.060 and 10.00 $\mu\text{S cm}^{-1}$ – **Signal Calc.** set to **Inf.pH(NH3)**
- 0.060 and 25.00 $\mu\text{S cm}^{-1}$ – **Signal Calc.** set to **Inf.pH(NH3+NaCl)**
- 1.000 and 100.0 $\mu\text{S cm}^{-1}$ – **Signal Calc.** set to **Inf.pH(NaOH)**

Return to main menu.

See Section 5.4.

5.4 Configure Alarms

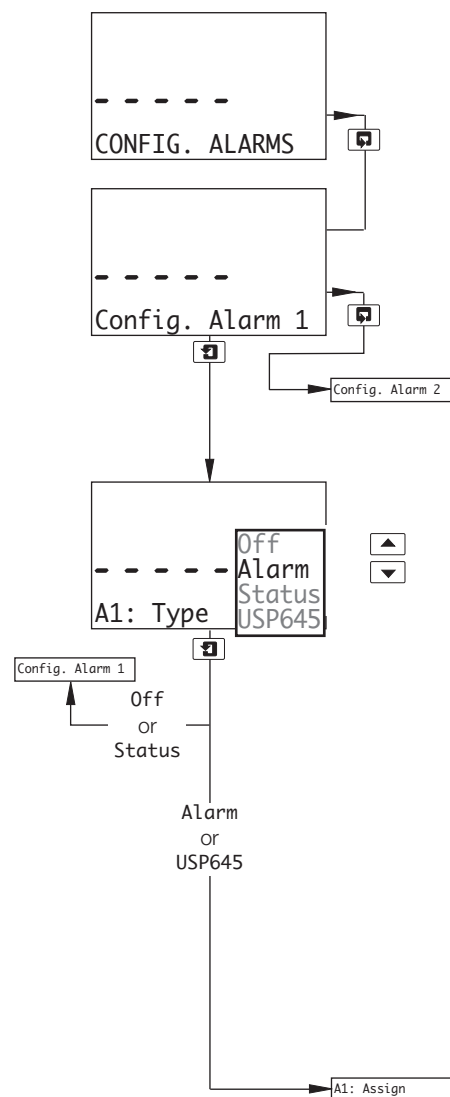

Configure Alarm 1

Alarm 2 and 3 configuration (and Alarms 4 and 5 if option board fitted **and** analog features enabled – see Section 7.3, page 62) is identical to Alarm 1.

Alarm 1 Type

Select the type of alarm required:

- Off** – The alarm is disabled, the alarm LED is off and the relay is de-energized at all times.
- Alarm** – The analyzer is configured using the Assign parameter (see next page) to generate an alarm in response to a specified sensor reading.
- Status** – An alarm is generated if either a power failure or a condition occurs that causes any of the error messages in Table 8.1 (page 68) to be displayed.
- USP645** – The alarm set point is set automatically to the value in Table 5.3 that corresponds with the sample temperature and changes automatically with changes in sample temperature. If the sample temperature is between the values given in the table, the alarm set point is set to the value corresponding to the nearest lower temperature, e.g. if the sample temperature is 29°C (84.2°F), the alarm set point is set automatically to 1.3µS cm⁻¹.

Note. The **USP645** alarm type is available only on AX450 and AX455 analyzers and only if **A: Cond.Units** is set to **USP645** – see Section 5.3, page 21.

Continued on next page.

Sample Temperature		USP645 Alarm Set Point Value (µS cm ⁻¹)
(°C)	(°F)	
0	32	0.6
5	41	0.8
10	50	0.9
15	59	1.0
20	68	1.1
25	77	1.3
30	86	1.4

Sample Temperature		USP645 Alarm Set Point Value (µS cm ⁻¹)
(°C)	(°F)	
35	95	1.5
40	104	1.7
45	113	1.8
50	122	1.9
55	131	2.1
60	140	2.2
65	149	2.4

Sample Temperature		USP645 Alarm Set Point Value (µS cm ⁻¹)
(°C)	(°F)	
70	158	2.5
75	167	2.7
80	176	2.7
85	185	2.7
90	194	2.7
95	203	2.9
100	212	3.1

Table 5.3 USP645 Alarm Set Point Values

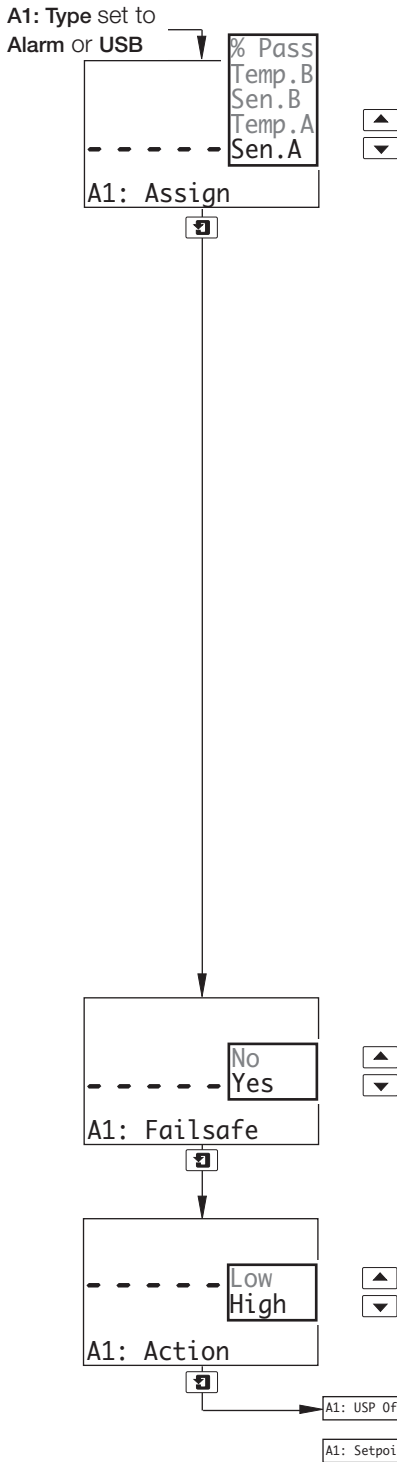

Alarm 1 Assign

Select the alarm assignment required:

- Sen. A** – The analyzer activates an alarm if the conductivity of the process fluid measured by the selected sensor exceeds or drops below the value set in the **Alarm 1 Set Point** parameter (see next page), depending on the type of **Alarm 1 Action** selected – see below.
- Temp. A** – The analyzer activates an alarm if the temperature of the process fluid measured by the selected sensor exceeds or drops below the value set in the **Alarm 1 Set Point** parameter (see next page), depending on the type of **Alarm 1 Action** selected – see below.

Notes.

- If **A1: Type** is set to **USP645**, the alarm is assignable only to **Sen.A** (and **B1: Type/Sen.B**, if dual input analyzer).
- The **Sen.B** and **Temp.B** alarm assignment types are applicable only to dual input analyzers.
- If **Signal Calc.** (dual input analyzers only) is set to any parameter other than **No Calculation** (page 28), the selected parameter is displayed:
 - % – **Signal Calc.** set to **% Passage**
 - Pass – **Signal Calc.** set to **% Rejection**
 - % Rej – **Signal Calc.** set to **Difference A – B**
 - A – B – **Signal Calc.** set to **Ratio A/B**
 - A/B – **Signal Calc.** set to **Inf.pH(NH3), Inf.pH(NH3+NaCl) or Inf.pH(NaOH)** (see Appendix A.3, page 75 for further information on inferred pH)

The analyzer activates an alarm if the value of the calculation exceeds or drops below the value set in **Alarm 1 Set Point** (see next page), depending on the type of **Alarm 1 Action** selected – see below.

Alarm 1 Failsafe

If failsafe action is required select **Yes**, otherwise select **No**.

See also Fig. 5.1 to Fig. 5.5 (page 33).

Alarm 1 Action

Select the alarm action required, **High** or **Low**.

See also Fig. 5.1 to Fig. 5.5 (page 33).

A1: Type set to **USP645** (AX450 and AX455 analyzers only) – continued on next page.

AX410 and AX411 analyzers or **A1: Type** not set to **USP645** (AX450 and AX455 analyzers only) – continued on next page.

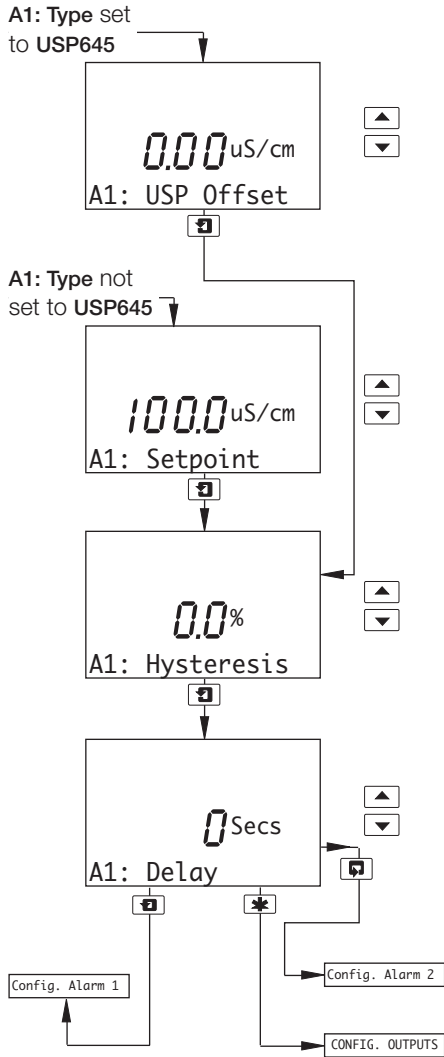

USP Offset

Enables the USP645 alarm set point value to be adjusted for increased process protection, i.e. the USP alarm set point value in Table 5.3 is offset by the amount entered (table value – offset value) to enable the alarm to be triggered early.

Note. The **USP Offset** parameter is available only on AX450 and AX455 analyzers and only if **A: Cond.Units** is set to **USP645** (Section 5.3) and **A1: Type** is set to **USP645**.

Alarm 1 Set Point

Set the alarm set point to a value within the input range being displayed – see Table 5.2 (page 22).

Alarm 1 Hysteresis

A differential set point can be defined between 0 and 5% of the alarm set point value. Set the required hysteresis in 0.1% increments.

See also Fig. 5.1 to Fig. 5.5 (page 33).

Alarm 1 Delay

If an alarm condition occurs, activation of the relays and LEDs can be delayed for a specified time period. If the alarm clears within the period, the alarm is not activated.

Set the required delay, in the range 0 to 60 seconds in 1 second increments. See also Fig. 5.1 to Fig. 5.5 (page 33).

Alarms 2 and 3 configuration (and Alarms 4 and 5 if option board fitted **and** analog features enabled – see Section 7.3, page 62) is identical to Alarm 1.

See Section 5.5.

Note. The following examples illustrate **High Alarm Actions**, i.e. the alarm is activated when the process variable exceeds the defined set point. **Low Alarm Actions** are the same, except the alarm is activated when the process variable drops below the defined set point.

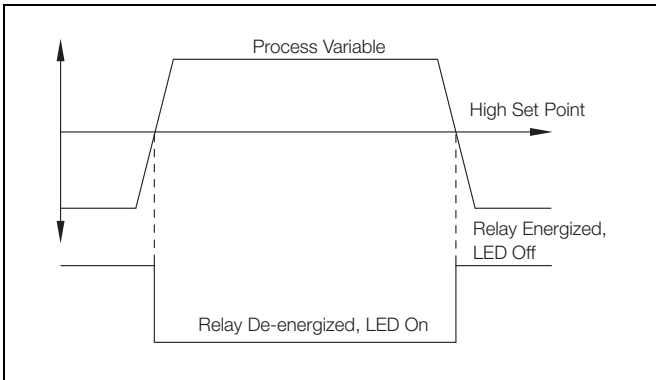

Fig. 5.1 High Failsafe Alarm without Hysteresis and Delay

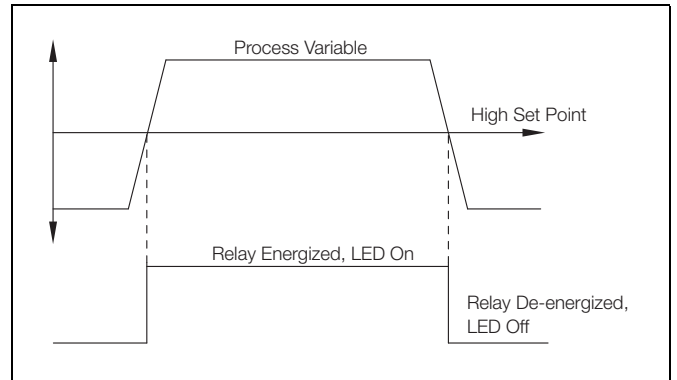

Fig. 5.4 High Non-Failsafe Alarm without Delay and Hysteresis

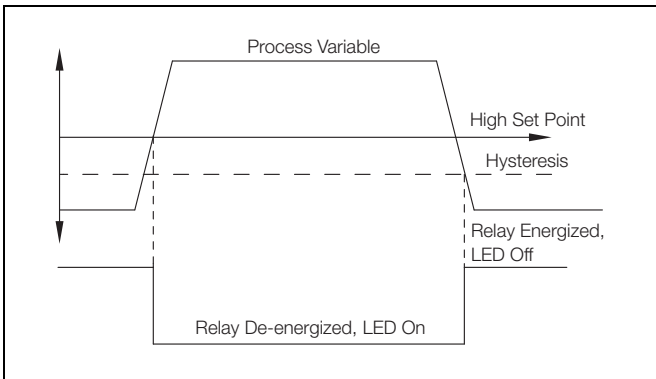

Fig. 5.2 High Failsafe Alarm with Hysteresis but no Delay

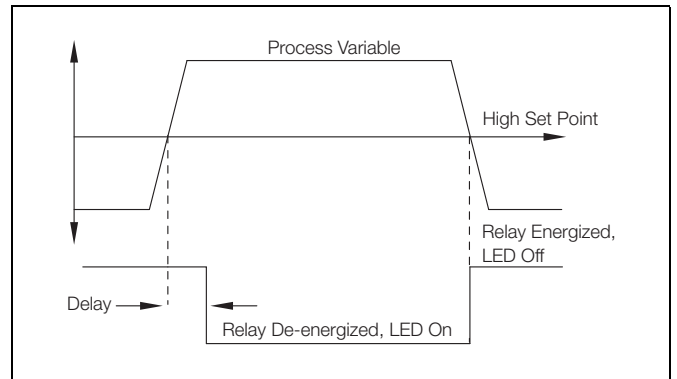

Fig. 5.5 High Failsafe Alarm with Delay but no Hysteresis

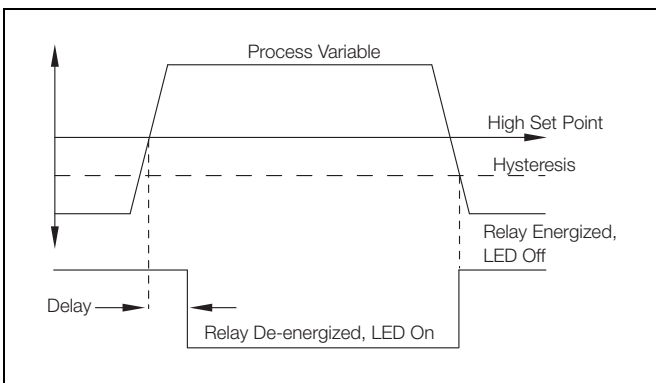
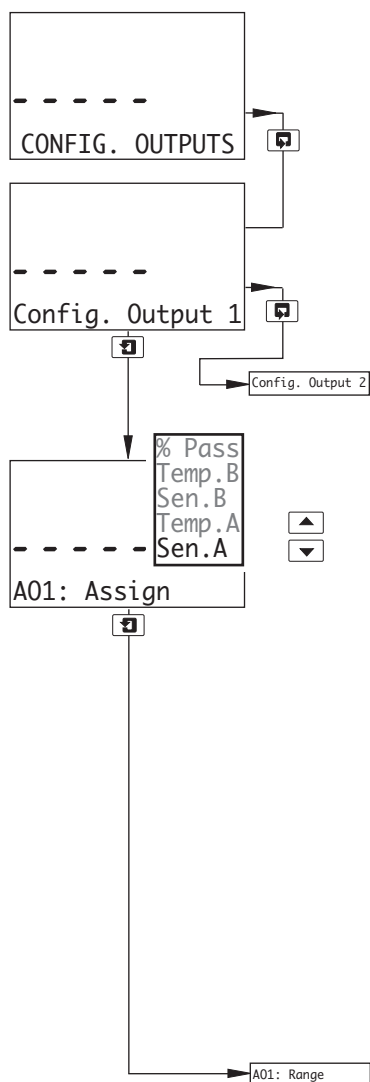

Fig. 5.3 High Failsafe Alarm with Hysteresis and Delay

5.5 Configure Outputs



Configure Output 1

Output 2 configuration (and Outputs 3 and 4 if option board fitted **and** analog features enabled – see Section 7.3, page 62) is identical to Output 1 configuration.

Assign

Select the sensor and analog output required:

- | | | |
|--------|---|---|
| Sen.A | } | – Conductivity for the selected sensor. |
| Sen.B | | |
| Temp.A | } | – Temperature for the selected sensor. |
| Temp.B | | |

Notes.

- **Sen.B** and **Temp.B** are applicable only to dual input analyzers.
- If **Signal Calc.** (dual input analyzers only) is set to any parameter other than **No Calculation** (page 28), the selected parameter is displayed:

- | | | |
|--------|---|--|
| % Pass | – | Signal Calc. set to % Passage |
| % Rej | – | Signal Calc. set to % Rejection |
| A – B | – | Signal Calc. set to Difference A – B |
| A/B | – | Signal Calc. set to Ratio A/B |
| pH | – | Signal Calc. set to Inf.pH(NH3), Inf.pH(NH3+NaCl) or Inf.pH(NaOH)
(see Appendix A.3 for further information on inferred pH) |

Continued on next page.

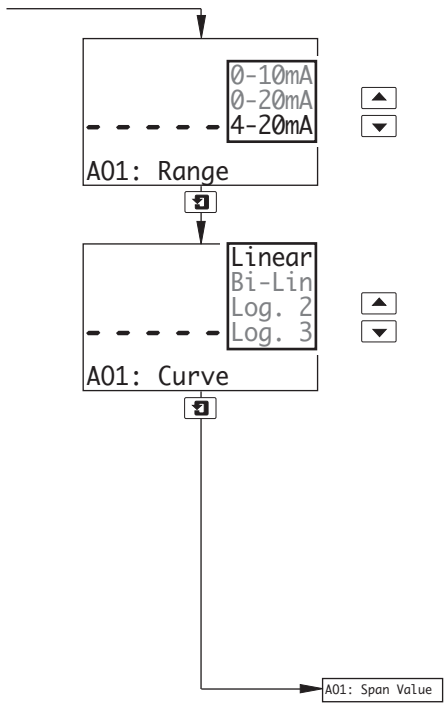

Range

Set the analog output current range for the selected output.

Curve

Select the analog output scale required.

- Linear** – Straight line between zero and span
- Bi-Lin** – Bi-linear – see Fig. 5.6 on page 39
- Log. 2** – Logarithmic, 2-decades – see Fig. 5.7 on page 39
- Log. 3** – Logarithmic, 3-decades – see Fig. 5.8 on page 40

Note. The curve is fixed to **Linear** if:

- a) the analog output is assigned to temperature
- or**
- b) the analog output is assigned to Sensor A or Sensor B (dual input analyzers only) **and Cond.Units** is set to **M.Ohms** (Section 5.3).

Continued on next page.

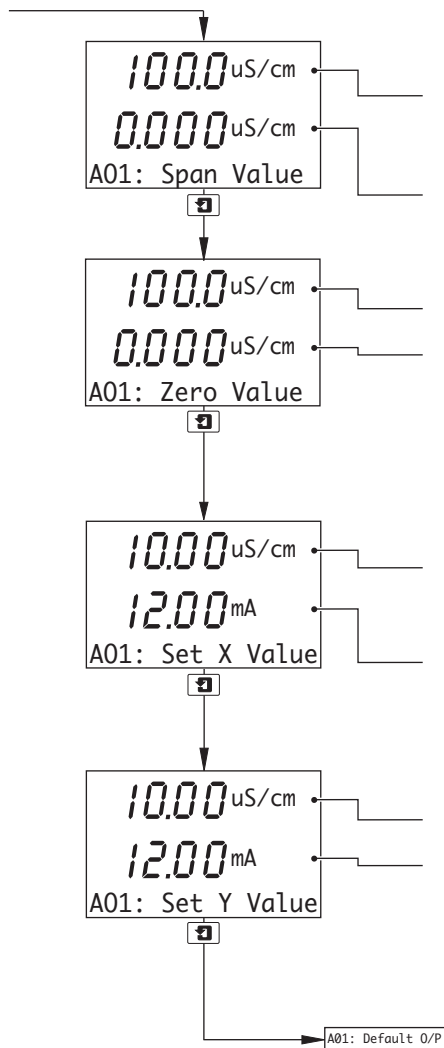

Span Value

uS/cm and **Adjust** are shown alternately on the upper display line. Use the ▲ and ▼ keys to adjust the displayed reading to the required span value. This is Point A in Fig. 5.6.

Zero value.

Zero Value

Span value.

uS/cm and **Adjust** are shown alternately on the center display line. Use the ▲ and ▼ keys to adjust the displayed reading to the required zero value. This is Point D in Fig. 5.6.

Note. Applicable only if the **Curve** parameter is set to **Linear** or **Bi-Lin** – see previous page. When set to **Log. 2** and **Log. 3**, the zero value is set automatically.

Set Breakpoint X Value

uS/cm and **Adjust** are shown alternately on the upper display line. Use the ▲ and ▼ keys to adjust the displayed reading to the required breakpoint conductivity value. This is Point B in Fig. 5.6.

Current value at which the breakpoint occurs.

Note. Applicable only if the **Curve** parameter is set to **Bi-Lin** – see previous page.

Set Breakpoint Y Value

Conductivity value at which the breakpoint occurs.

mA and **Adjust** are shown alternately on the center display line. Use the ▲ and ▼ keys to adjust the displayed reading to the required breakpoint current value. This is Point C in Fig. 5.6.

Note. Applicable only if the **Curve** parameter is set to **Bi-Lin** – see previous page.

Continued on next page.

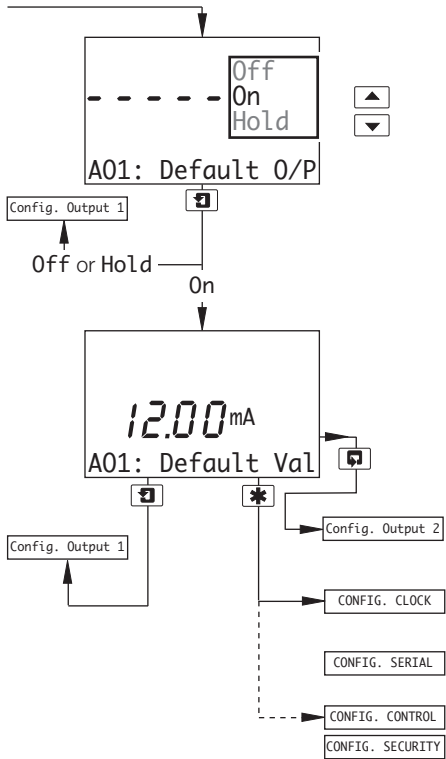

Default Output

Select the system reaction to failure:

- Off** – Ignore failure and continue operation.
- On** – Stop on failure. This drives the analog output to the level set in the **Default Val** frame below.
- Hold** – Hold the analog output at the value prior to the failure.

Default Value

The level to which the analog output is driven if a failure occurs.

Set the value between 0.00 and 22.00mA.

Output 2 configuration (and Outputs 3 and 4 if option board fitted **and** analog features enabled – see Section 7.3, page 62) is identical to Output 1 configuration.

Option board fitted **and** analog features enabled (Section 7.3) – see Section 5.7, page 41.

Option board fitted **and** Serial Communications feature enabled (Section 7.3) – see Supplementary Manual *Profibus® Datalink Description (IM/AX4/PBS)*.

Single input analyzer **and** option board not fitted – see Section 5.8, page 42.

Dual input analyzer **and** option board not fitted – see Section 5.9, page 47.

		Maximum Effective TDS Range (ppm, mg/kg and mg/l)				
Conductivity Cell Constant (K)	Maximum Conductivity Range ($\mu\text{S cm}^{-1}$)	TDS Factor (examples)				
		0.40	0.50	0.60	0.70	0.80
0.1	0 to 1,000	0 to 400	0 to 500	0 to 600	0 to 700	0 to 800
1.0	0 to 10,000	0 to 4,000	0 to 5,000	0 to 6,000	0 to 7,000	0 to 8,000

Table 5.4 Analog Outputs – TDS Ranges

Conductivity Cell Constant (K)	Minimum Conductivity Range	Maximum Conductivity Range
0.01	0 to $0.1\mu\text{S cm}^{-1}$ 0 to $10.00\mu\text{S m}^{-1}$	0 to $100.0\mu\text{S cm}^{-1}$ 0 to $10,000\mu\text{S m}^{-1}$
0.05	0 to $0.5\mu\text{S cm}^{-1}$ 0 to $50.00\mu\text{S m}^{-1}$	0 to $500.0\mu\text{S cm}^{-1}$ 0 to $10,000\mu\text{S m}^{-1}$
0.10	0 to $1\mu\text{S cm}^{-1}$ 0 to $100\mu\text{S m}^{-1}$ 0 to 0.1mS m^{-1}	0 to $1,000\mu\text{S cm}^{-1}$ 0 to $10,000\mu\text{S m}^{-1}$ 0 to 100.0mS m^{-1}
1.00	0 to $10\mu\text{S cm}^{-1}$ 0 to $1,000\mu\text{S m}^{-1}$ 0 to 0.01mS cm^{-1} 0 to 1mS m^{-1}	0 to $10,000\mu\text{S cm}^{-1}$ 0 to $10,000\mu\text{S m}^{-1}$ 0 to 10mS cm^{-1} 0 to $1,000\text{mS m}^{-1}$

Table 5.5 Analog Outputs – Conductivity Ranges

Analog Output Assignment	Analog Output Span
Temperature ($^{\circ}\text{C}$)	150 (maximum), -10 (minimum) – subject to minimum range of 20°C
Temperature ($^{\circ}\text{F}$)	302 (maximum), 14 (minimum) – subject to minimum range of 36°F

Table 5.6 Analog Outputs – Temperature Ranges

5.6 Output Functions

5.6.1 Bi-Linear Output – Fig. 5.6

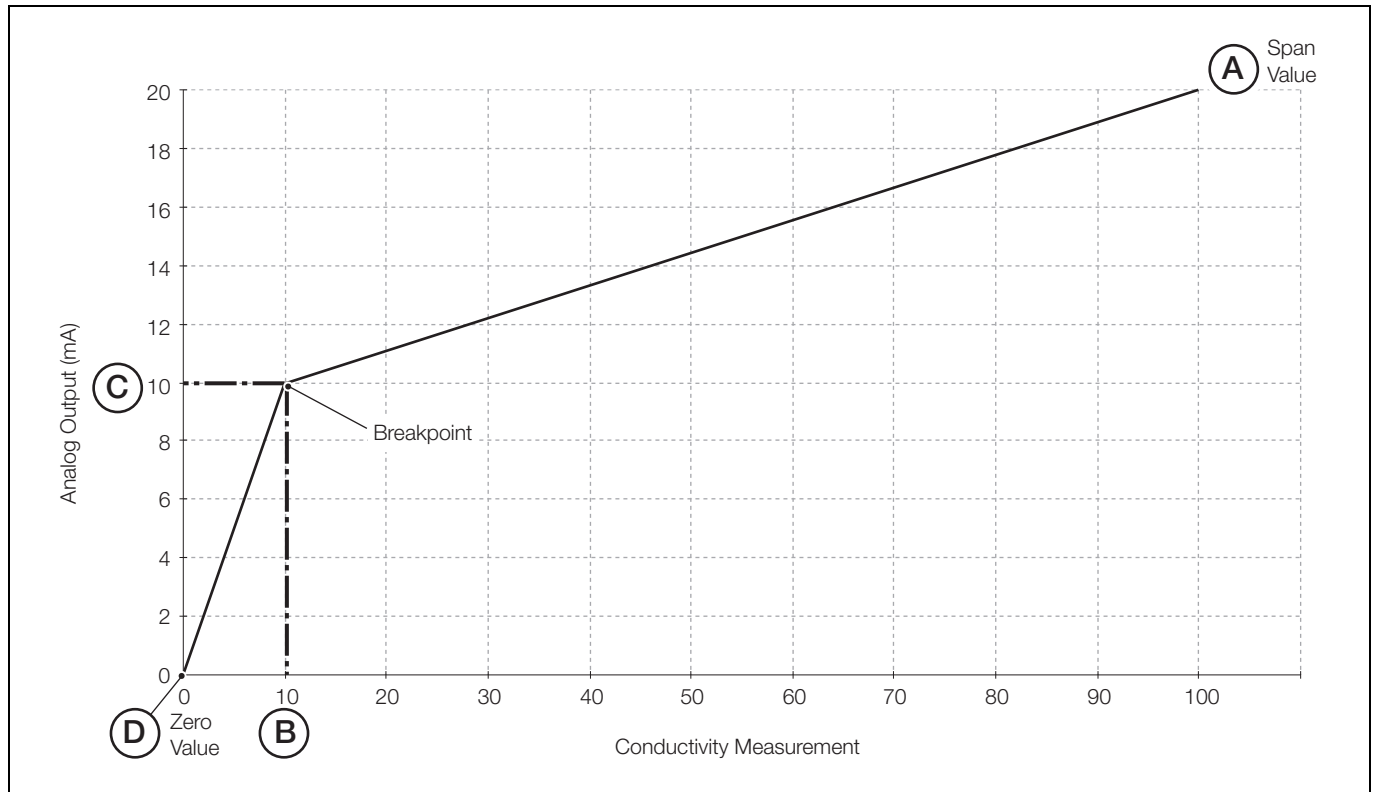

Fig. 5.6 Bi-Linear Output

5.6.2 Logarithmic Output (2-decade) – Fig. 5.7

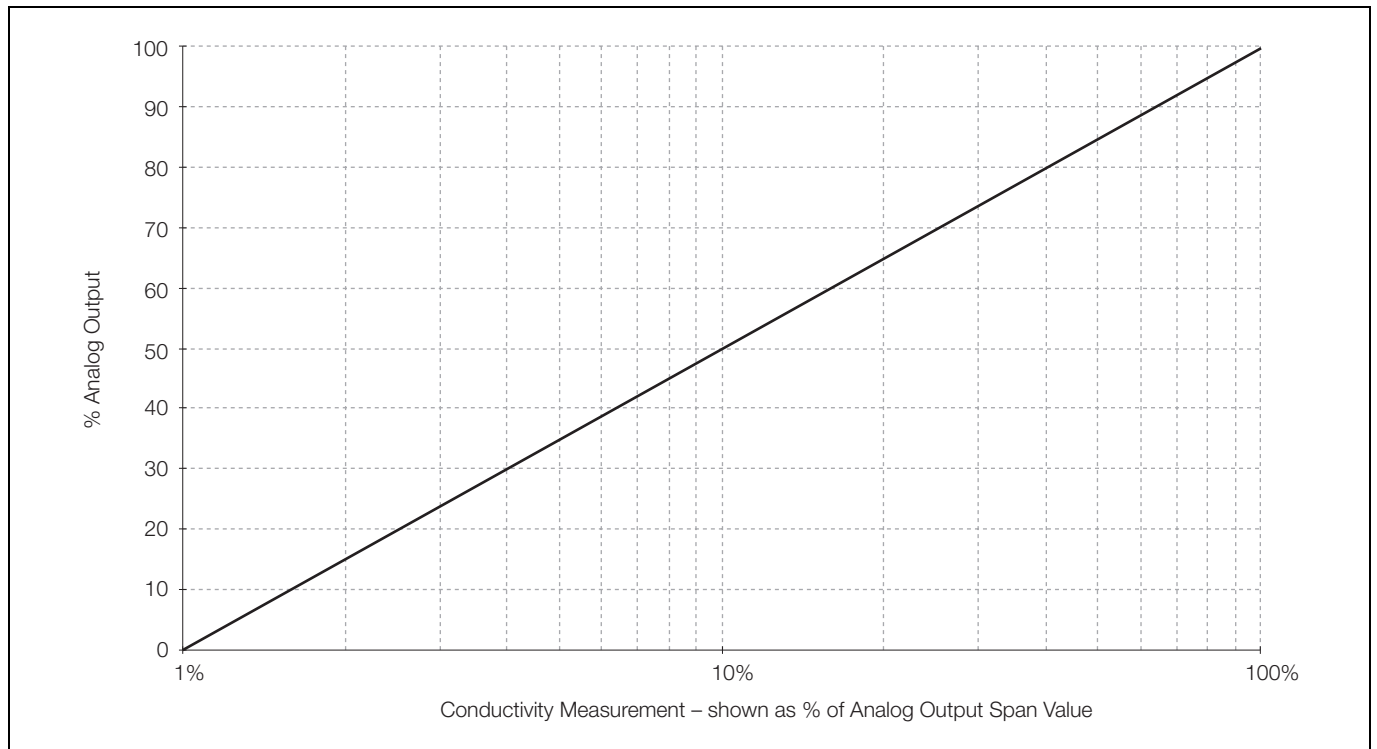

Fig. 5.7 Logarithmic Output (2-Decade)

5.6.3 Logarithmic Output (3-decade) – Fig. 5.8

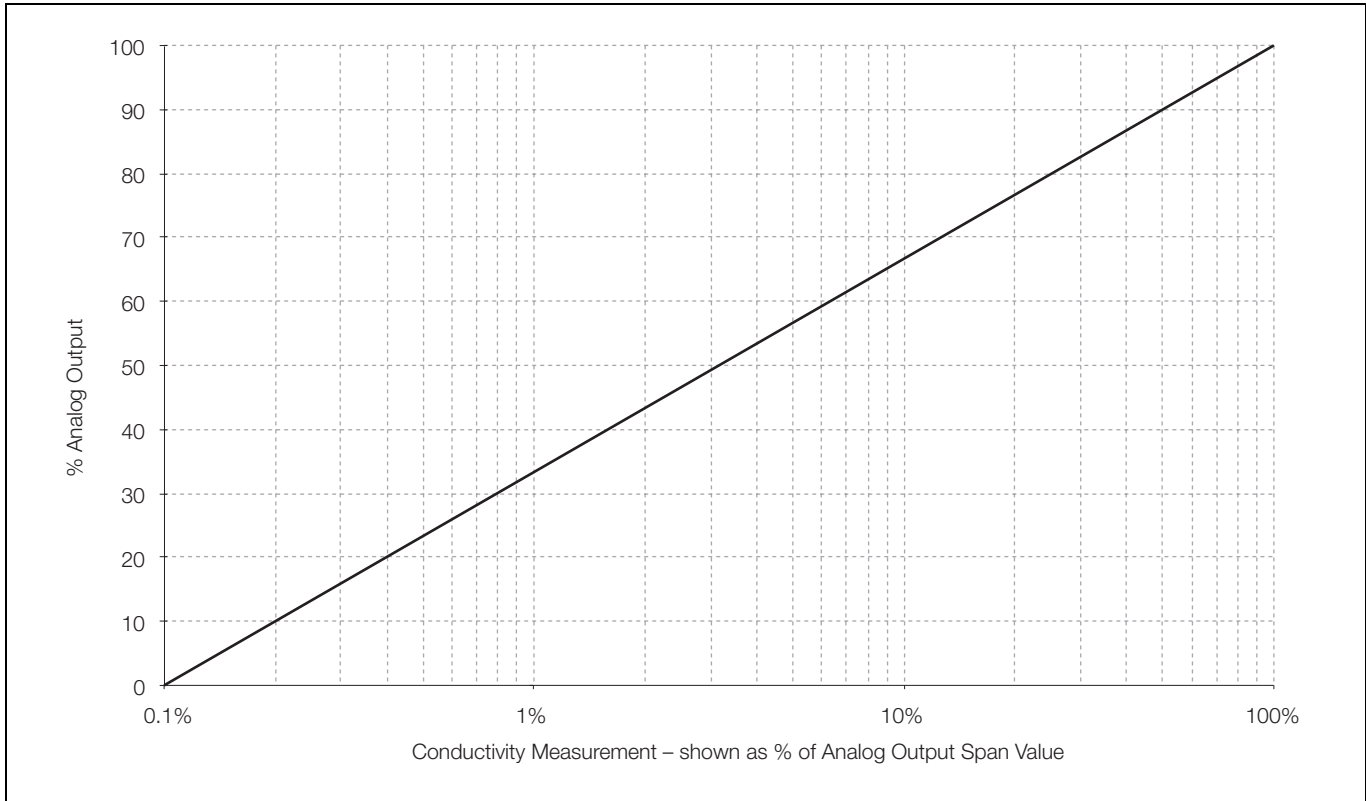
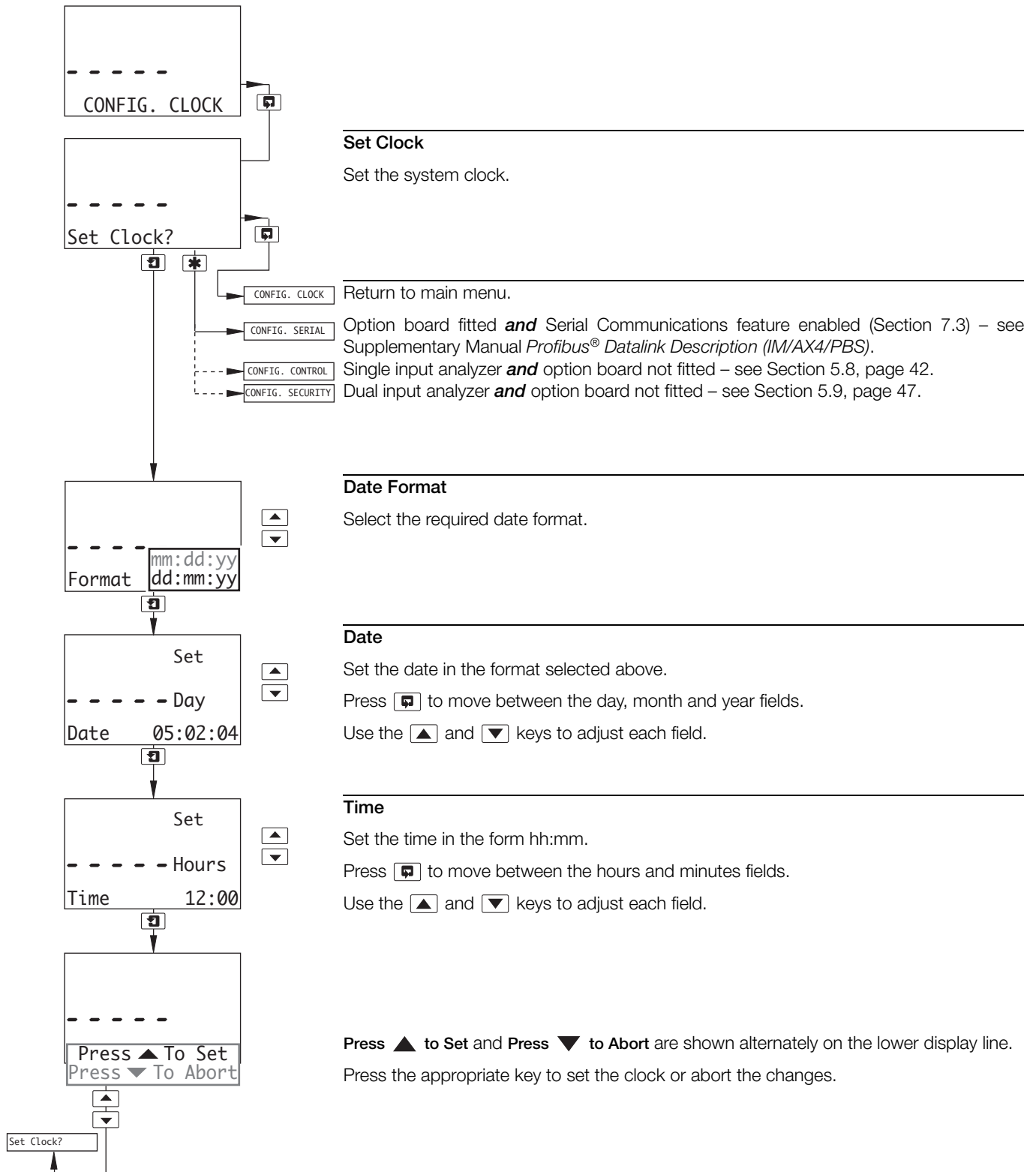

Fig. 5.8 Logarithmic Output (3-Decade)

5.7 Configure Clock

Note. The Configure Clock function is available only if the option board is fitted and analog features enabled – see Section 7.3, page 62.



5.8 Configure Control

Note.

- PID control is applicable only to single input analyzers.
- Before configuring the PID controller, refer to see Appendix B, page 78 for further information.

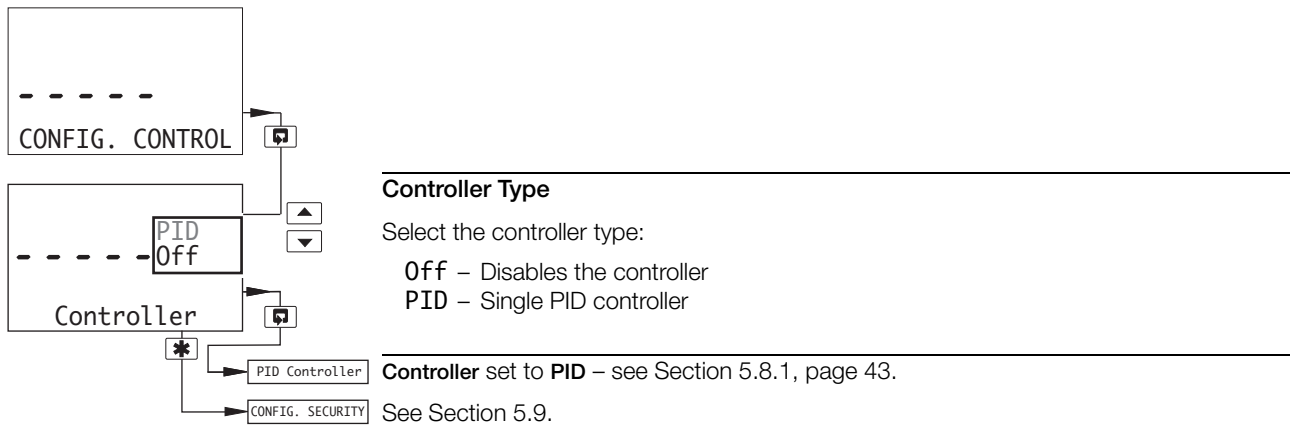

5.8.1 Configure Single PID Controller

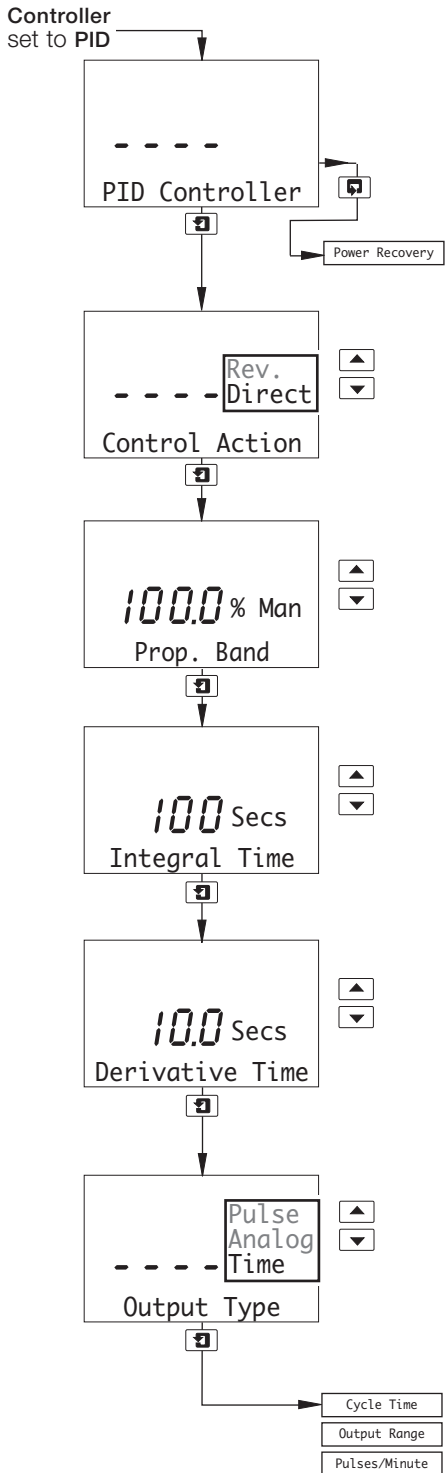

See Section 5.8.2.

Control Action

Set the required control action:

- Rev. – Reverse acting – see Appendix B, page 78, Fig. B.2.
- Direct – Direct acting – see Appendix B, page 78, Fig. B.3.

Proportional Band

Set the required proportional band, between 0.0 and 999.9% in 0.1% increments.

Integral Action Time

Set the integral action time, between 1 and 7200 seconds in 1 second increments.
 Set to **OFF** to disable integral action time.

Derivative Action Time

Set the derivative action time, between 0.1 and 999.9 seconds in 0.1 second increments.
 Set to **OFF** to disable derivative action time.

Output Type

Set the required output type:

- Time – Time proportioning (relay 1)
- Analog – Analog output (analog output 1)
- Pulse – Pulse frequency (relay 1)

Output Type set to Time – continued on next page.

Output Type set to Analog – continued on next page.

Output Type set to Pulse – continued on page 45.

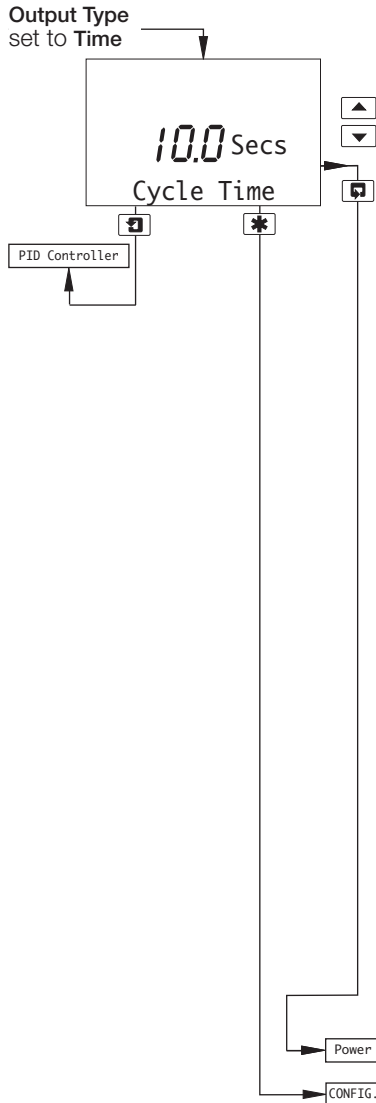

Time Proportioning Output

The Time Proportioning Output is interrelated to the retention time of the vessel and the flow of the chemical reagent and is adjusted experimentally to ensure that the chemical reagent is adequate to control the dosing under maximum loading. It is recommended that the Time Proportioning Output is adjusted in Manual Mode set to 100% valve output before setting up the PID parameters.

The time proportioning output value is calculated using the following equation:

$$\text{on time} = \frac{\text{control output} \times \text{cycle time}}{100}$$

Set the cycle time, between 1.0 and 300.0 seconds in 0.1 second increments – see Appendix B, page 78, Fig. B.4 Mode C.

Note. Changes to the cycle time do not take effect until the start of a new cycle.

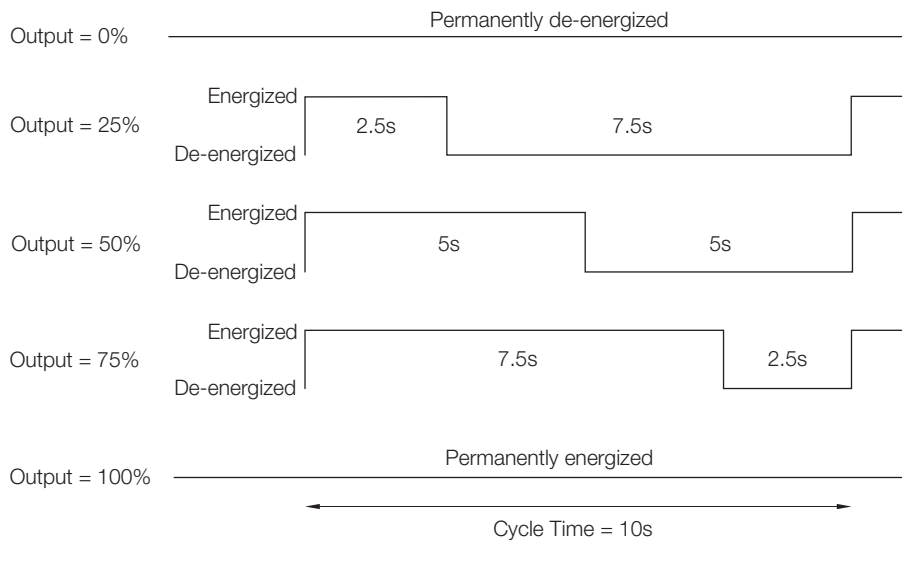

See Section 5.8.2.

See Section 5.9.

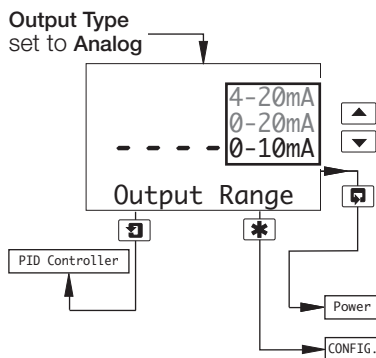

Analog Output

Set the analog current output range.

See Section 5.8.2.

See Section 5.9.

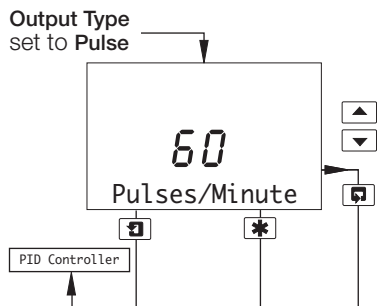

Pulse Frequency Output

The pulse frequency output is the number of relay pulses per minute required for 100% control output. The Pulse Frequency Output is interrelated to the chemical reagent strength and the solution flow rate. The chemical reagent flowrate and pulse frequency is adjusted experimentally to ensure that the chemical reagent is adequate to control the dosing under maximum loading. Adjust the Pulse Frequency Output in Manual Mode and set to 100% valve output before setting up the PID parameters.

For example, if the observed value on the display is 6 and the control point is 5 then the frequency needs to be increased.

The actual number of pulses per minute is calculated using the following equation:

$$\text{Actual pulses per minute} = \frac{\% \text{ control output} \times \text{pulse frequency output}}{100}$$

Set the pulse frequency between 1 and 120 pulses per minute in 1 pulse per minute increments.

Control Output	Pulse Frequency Output/Minute			
	1	10	50	120
0	0	0	0	0
25	0.25	2.5	12.5	30
50	0.50	5.0	25	60
75	0.75	7.5	37.5	90
100	1.00	10.0	50	120

Note. If the pulse frequency of 120 is reached then concentration of the reagent needs to be increased.

Note. Changes to the pulse frequency do not take effect until the start of a new cycle.

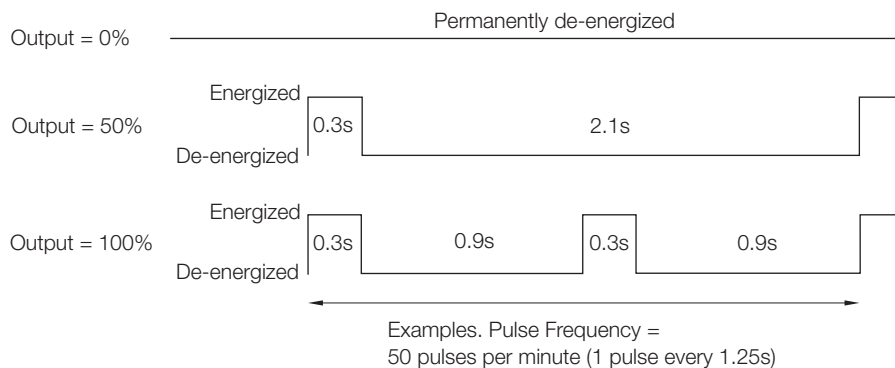

Power Recovery See Section 5.8.2.

CONFIG. SECURITY See Section 5.9.

5.8.2 Configure Power Failure Recovery Mode

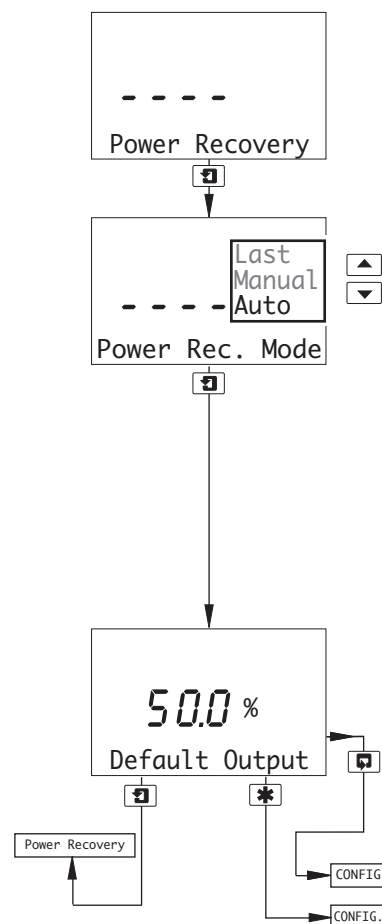

Power Failure Recovery Mode

When power to the analyzer is restored, **Control Mode** (Section 2.3) is set automatically according to the Power Failure Recovery Mode selected in this frame.

Select the required mode:

- Auto** – **Control Mode** is set to **Auto** irrespective of its setting prior to the power failure.
- Manual** – **Control Mode** is set to **Manual** irrespective of its setting prior to the power failure. **Control Output** (Section 2.3) is set to the level set in the **Default Output** frame below.
- Last** – **Control Mode** and **Control Output** are set to the same state as that set prior to the power failure.

Default Output

Set the default output required after Power Failure Recovery, between 0 and 100% in 0.1% increments.

Note. A setting of 0% represents no output.

Return to main menu.

See Section 5.9.

5.9 Configure Security

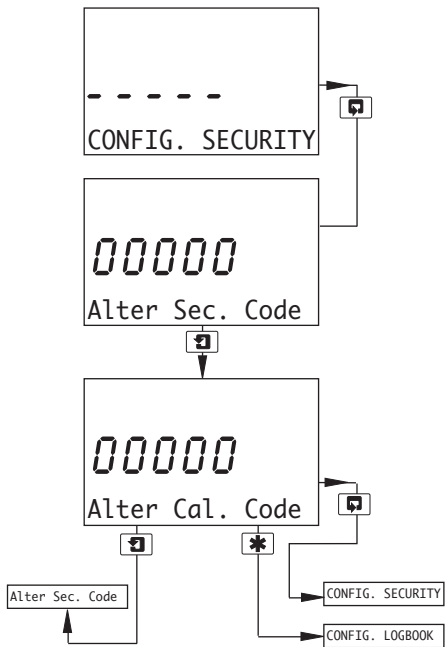

Alter Security Code

Set the security code to a value between 0000 and 19999.

Alter Calibration Code

Set the sensor calibration access code to a value between 0000 and 19999.

Return to main menu.

Option board fitted **and** analog features enabled (Section 7.3) – see Section 5.10, page 47.

5.10 Configure Logbook

Note. The Configure Logbook function is available only if the option board is fitted **and** analog features enabled – see Section 7.3, page 62.

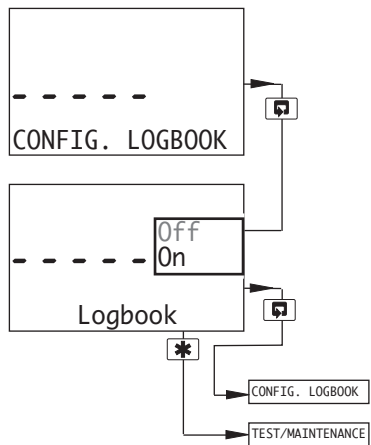

Configure Logbook

Use the ▲ and ▼ keys to set the logbook **On** or **Off**.
 If **Off** is selected, all data entries in the logbook are cleared.

Return to main menu.

See Section 5.11.

5.11 Test Outputs and Maintenance

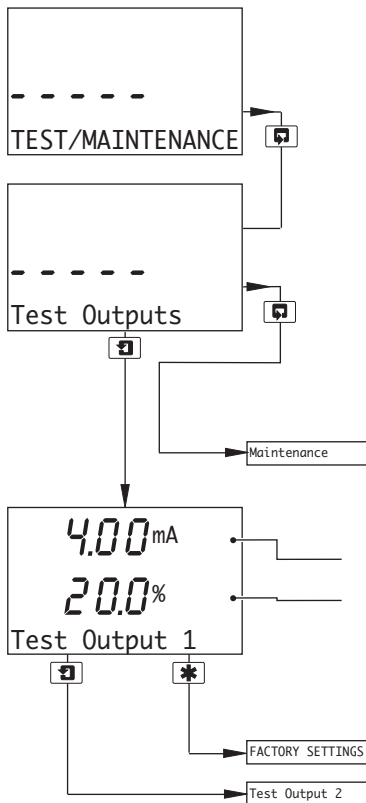

Test Outputs

Displays the output test details for the analog outputs.

Note. Outputs 3 and 4 are available only if the option board is fitted **and** analog features enabled – see Section 7.3, page 62.

Test Output 1 frame only is shown; the format of frames for the remaining outputs is identical.

See below.

Test Output 1

The theoretical output current value.

Output current as a percentage of the full range current.

Use the ▲ and ▼ keys to adjust the displayed theoretical output current value to give the output required.

See Section 7.3.

Test remaining outputs.

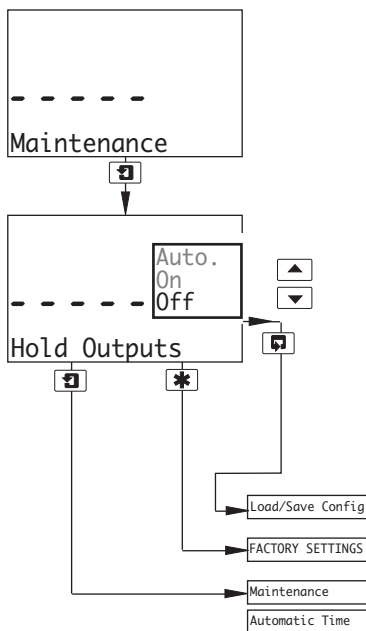

Maintenance

Hold Outputs

Enables the relay action and analog outputs to be maintained.

Auto. – Changes in relay action and analog outputs are disabled during sensor calibration.

On – Changes in relay action and analog outputs are disabled.

Off – Changes in relay action and analog outputs are enabled.

Note. The LEDs flash while the analyzer is in 'Hold' mode.

Continued on next page.

See Section 7.3.

Hold Outputs set to **Off** or **On** – return to main menu.

Hold Outputs set to **Auto.** – continued on next page.

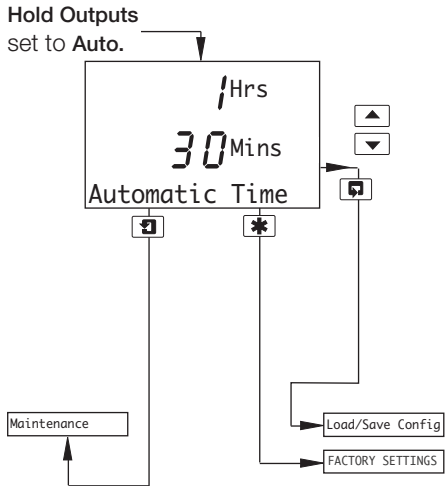

Automatic Time

If required, set a time period between 1 and 6 hours, in 30 minute increments, for which the outputs are held when **Hold Outputs** is set to **Auto**.

At the default setting of **None**, changes in relay action and analog outputs are disabled during sensor calibration and enabled automatically at the end of the procedure.

If a time is set, changes in relay action and analog outputs are disabled during sensor calibration, but if the calibration is not completed within the set time, the calibration is aborted, the display returns to the Operating Page and **CAL. ABORTED** is displayed.

Continued below.

See Section 7.3.

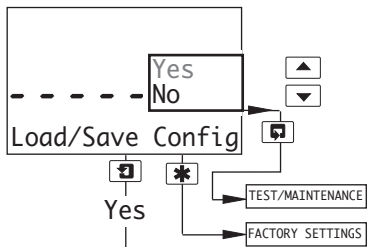

Load/Save Configuration

Select whether a configuration is to be loaded or saved.

Note. If **No** is selected, pressing the **F1** key has no effect.

Return to main menu.

See Section 7.3.

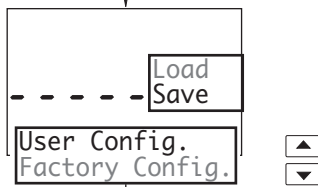

Load User/Factory Configuration

Note. Applicable only if **Load/Save Config** is set to **Yes**.

Factory Config. – resets all the parameters in the **Configuration Pages** to the Company Standard.

Save User Config. – saves the current configuration into memory.

Load User Config. – reads the saved user configuration into memory.

User Config. and **Factory Config.** are displayed alternately if a User Configuration has been saved previously. Use the **▲** and **▼** keys to make the required selection.

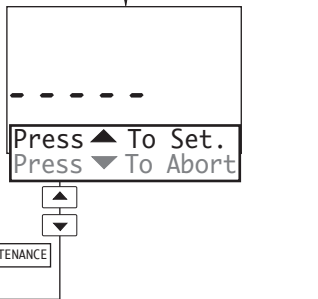

Press ▲ to Set and **Press ▼ to Abort** are displayed alternately on the lower display line.

Press the appropriate key to load/save the configuration or abort the changes.

6 Installation

6.1 Siting Requirements

Note.

- Mount in a location free from excessive vibration, and where the temperature and humidity specification will not be exceeded.
- Mount away from harmful vapors and/or dripping fluids and ensure that it is suitably protected from direct sunlight, rain, snow and hail.
- Where possible, mount the analyzer at eye level to allow an unrestricted view of the front panel displays and controls.

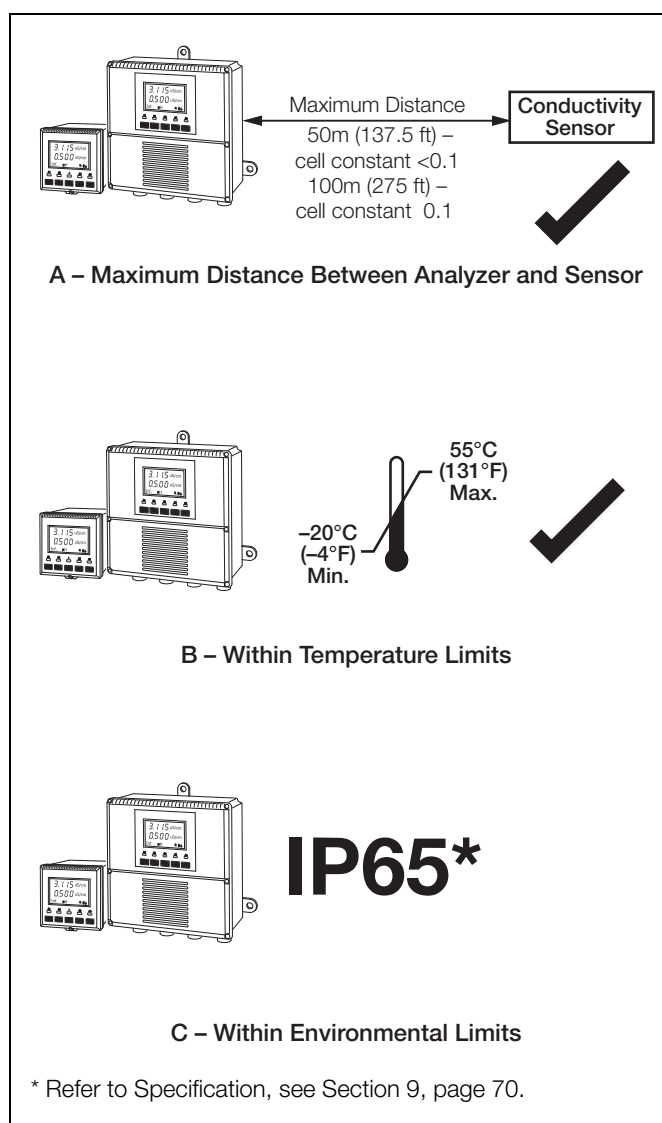

Fig. 6.1 Siting Requirements

6.2 Mounting

6.2.1 Wall-/Pipe-mount Analyzers – Figs. 6.2 and 6.3

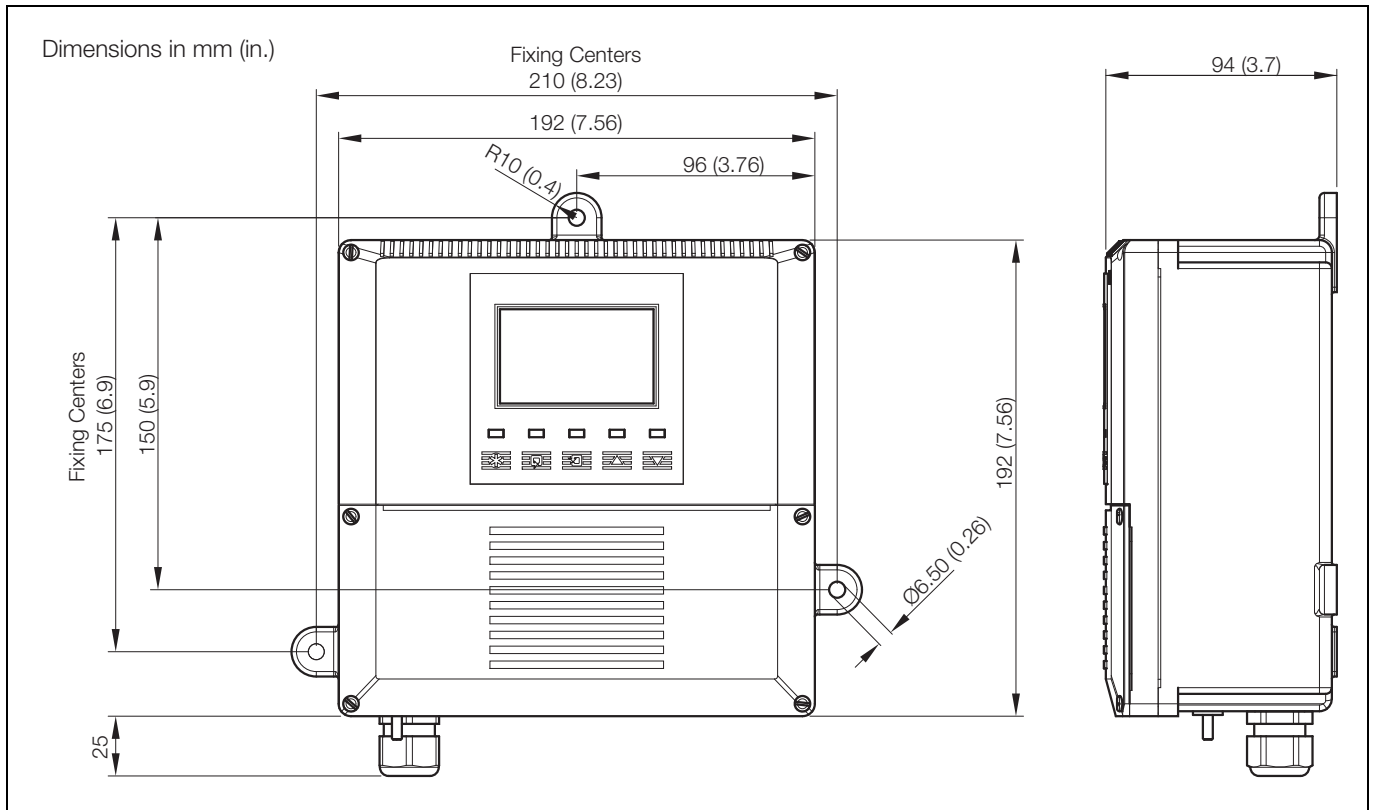

Fig. 6.2 Overall Dimensions

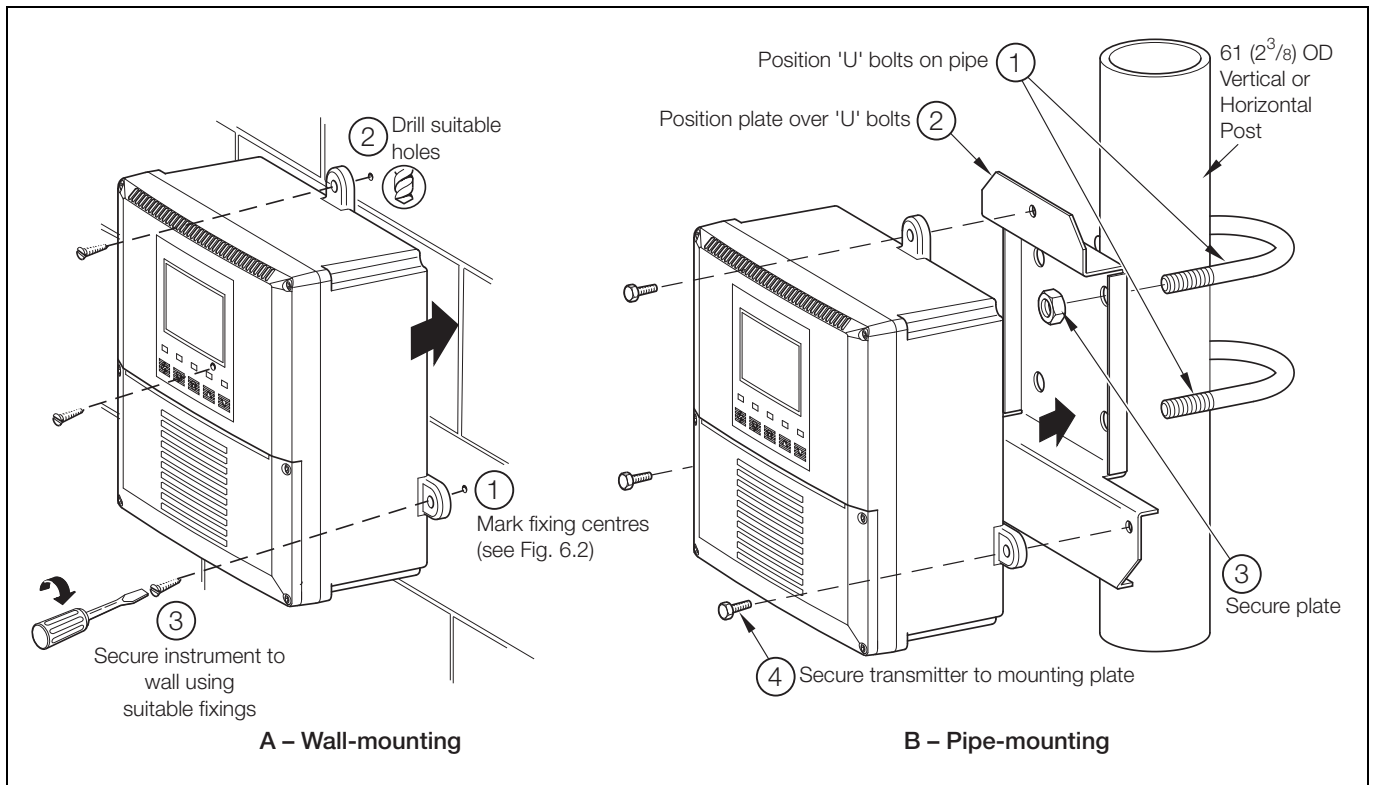

Fig. 6.3 Wall-/Pipe-mounting

6.2.2 Panel-mount Analyzers – Figs. 6.4 and 6.5

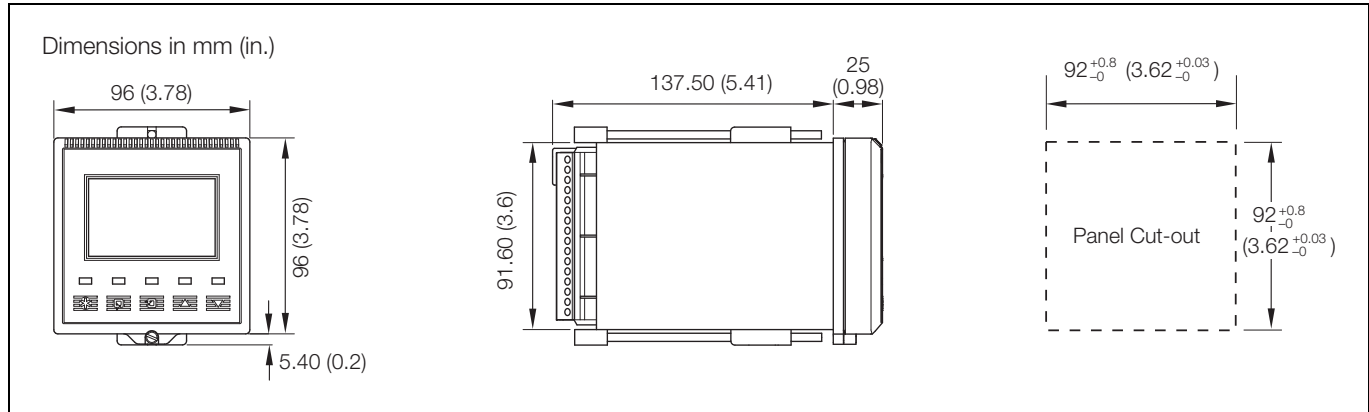

Fig. 6.4 Overall Dimensions

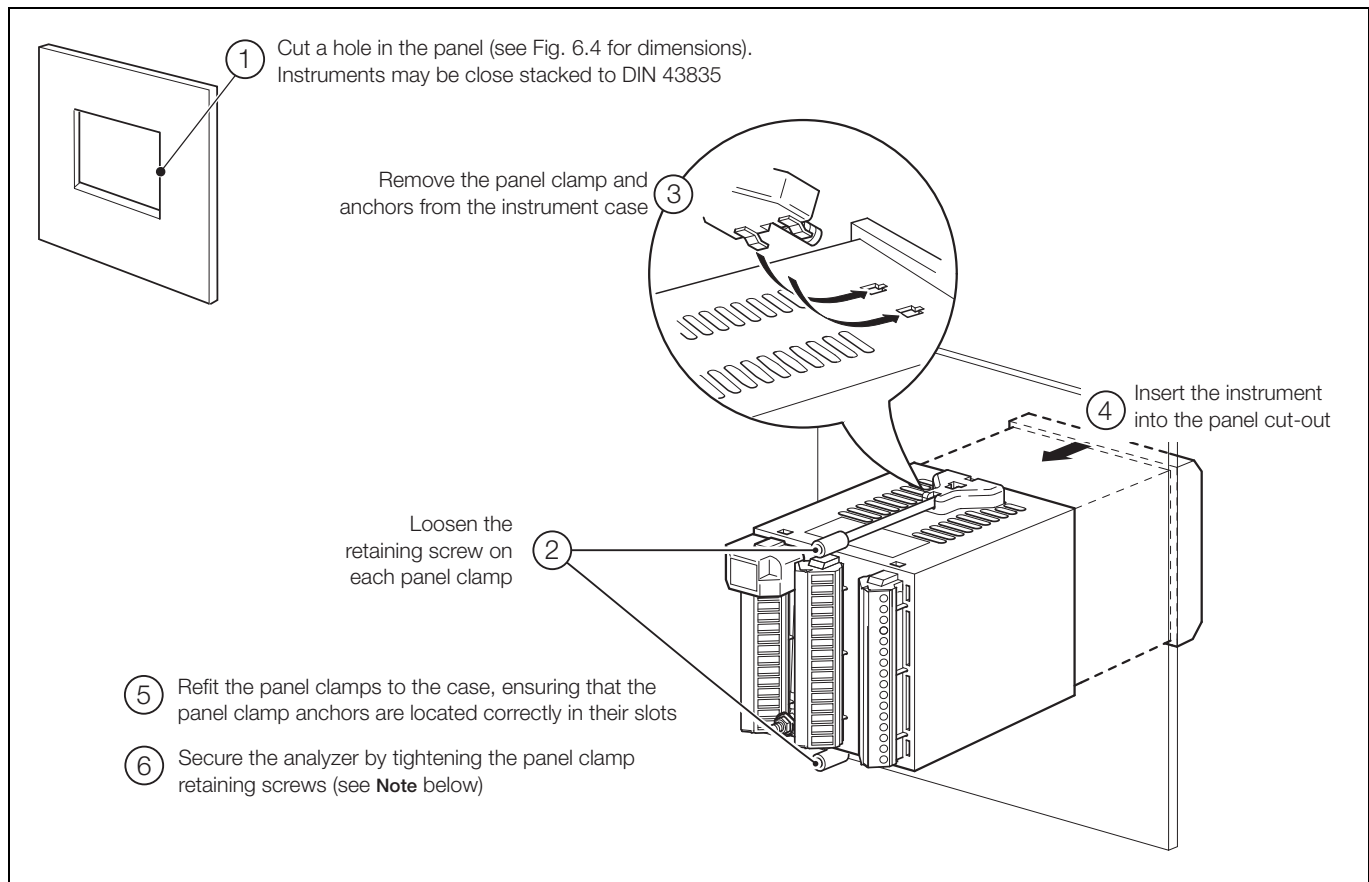

Fig. 6.5 Panel-mounting

Note. The clamp must fit flat on the analyzer casing. The clamp uses a torque limiter, so it is not possible to over-tighten the securing screws.

6.3 Connections, General

Warning.

- The instrument is not fitted with a switch therefore a disconnecting device such as a switch or circuit breaker conforming to local safety standards must be fitted to the final installation. It must be fitted in close proximity to the instrument within easy reach of the operator and must be marked clearly as the disconnection device for the instrument.
- Remove all power from supply, relay and any powered control circuits and high common mode voltages before accessing or making any connections.
- The power supply earth (ground) **must** be connected to reduce the effects of RFI interference and ensure the correct operation of the power supply interference filter.
- The power supply earth (ground) **must** be connected to the earth (ground) stud on the analyzer case – see Fig. 6.8 (wall-/pipe-mount analyzers) or Fig. 6.10 (panel-mount analyzers).
- Use cable appropriate for the load currents. The terminals accept cables from 20 to 14 AWG (0.5 to 2.5mm²) UL Category AVLV2.
- The instrument conforms to Mains Power Input Insulation Category III. All other inputs and outputs conform to Category II.
- All connections to secondary circuits must have basic insulation.
- After installation, there must be no access to live parts, e.g. terminals.
- Terminals for external circuits are for use only with equipment with no accessible live parts.
- The relay contacts are voltage-free and must be appropriately connected in series with the power supply and the alarm/control device which they are to actuate. Ensure that the contact rating is not exceeded. Refer also to Section 6.3.1 for relay contact protection details when the relays are to be used for switching loads.
- Do not exceed the maximum load specification for the selected analog output range.
The analog output is isolated, therefore the –ve terminal must be connected to earth (ground) if connecting to the isolated input of another device.
- If the instrument is used in a manner not specified by the Company, the protection provided by the equipment may be impaired.
- All equipment connected to the instrument's terminals must comply with local safety standards (IEC 60950, EN61010-1).

USA and Canada Only

- The supplied cable glands are provided for the connection of signal input and ethernet communication wiring ONLY.
- The supplied cable glands and use of cable / flexible cord for connection of the mains power source to the mains input and relay contact output terminals is not permitted in the USA or Canada.
- For connection to mains (mains input and relay contact outputs), use only suitably rated field wiring insulated copper conductors rated min. 300 V, 14 AWG, 90C. Route wires through suitably rated flexible conduits and fittings.

Note.

- An earthing (grounding) – stud terminal is fitted to the analyzer case for bus-bar earth (ground) connection – see Fig. 6.8 (wall-/pipe-mount analyzers) or Fig. 6.10 (panel-mount analyzers).
- Always route signal output/sensor cell cable leads and mains-carrying/relay cables separately, ideally in earthed (grounded) metal conduit. Use twisted pair output leads or screened cable with the screen connected to the case earth (ground) stud.
Ensure that the cables enter the analyzer through the glands nearest the appropriate screw terminals and are short and direct. Do not tuck excess cable into the terminal compartment.
- Ensure that the IP65 rating is not compromised when using cable glands, conduit fittings and blanking plugs/bungs (M20 holes). The M20 glands accept cable of between 5 and 9mm (0.2 and 0.35 in.) diameter.

6.3.1 Relay Contact Protection and Interference Suppression – Fig. 6.6

If the relays are used to switch loads on and off, the relay contacts can become eroded due to arcing. Arcing also generates radio frequency interference (RFI) which can result in analyzer malfunctions and incorrect readings. To minimize the effects of RFI, arc suppression components are required; resistor/capacitor networks for AC applications or diodes for DC applications. These components must be connected across the load – see Fig. 6.6.

For AC applications the value of the resistor/capacitor network depends on the load current and inductance that is switched. Initially, fit a 100R/0.022 μ F RC suppressor unit (part no. B9303) as shown in Fig. 6.6A. If the analyzer malfunctions (locks up, display goes blank, resets etc.) the value of the RC network is too low for suppression and an alternative value must be used. If the correct value cannot be obtained, contact the manufacturer of the switched device for details on the RC unit required.

For DC applications fit a diode as shown in Fig. 6.6B. For general applications use an IN5406 type (600V peak inverse voltage at 3A).

Note. For reliable switching the minimum voltage must be greater than 12V and the minimum current greater than 100mA.

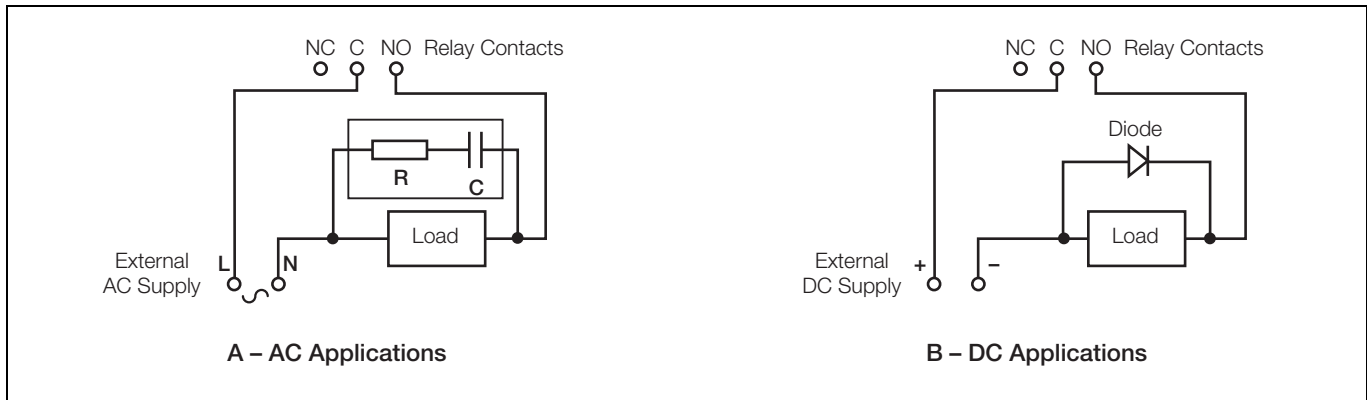

Fig. 6.6 Relay Contact Protection

6.3.2 Cable Entry Knockouts, Wall-/Pipe-mount Analyzer – Fig. 6.7

The analyzer is supplied with 7 cable glands, one fitted and six to be fitted, as required, by the user – see Fig. 6.7.

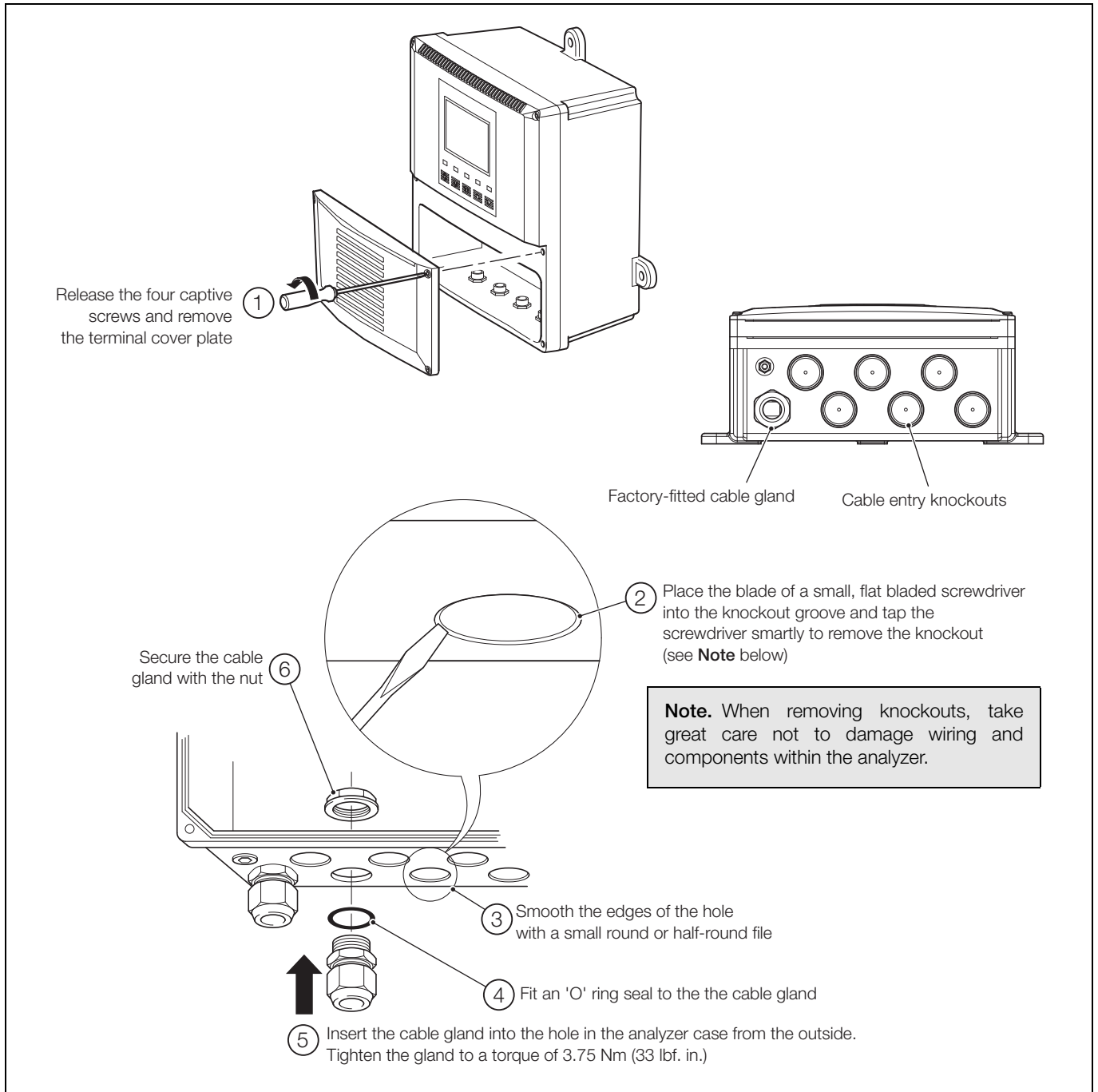

Fig. 6.7 Cable Entry Knockouts, Wall-/Pipe-mount Analyzer

Note. The cable glands must be tightened to a torque of 3.75 Nm (33 lbf. in.)

6.4 Wall-/Pipe-mount Analyzer Connections

6.4.1 Access to Terminals – Fig. 6.8

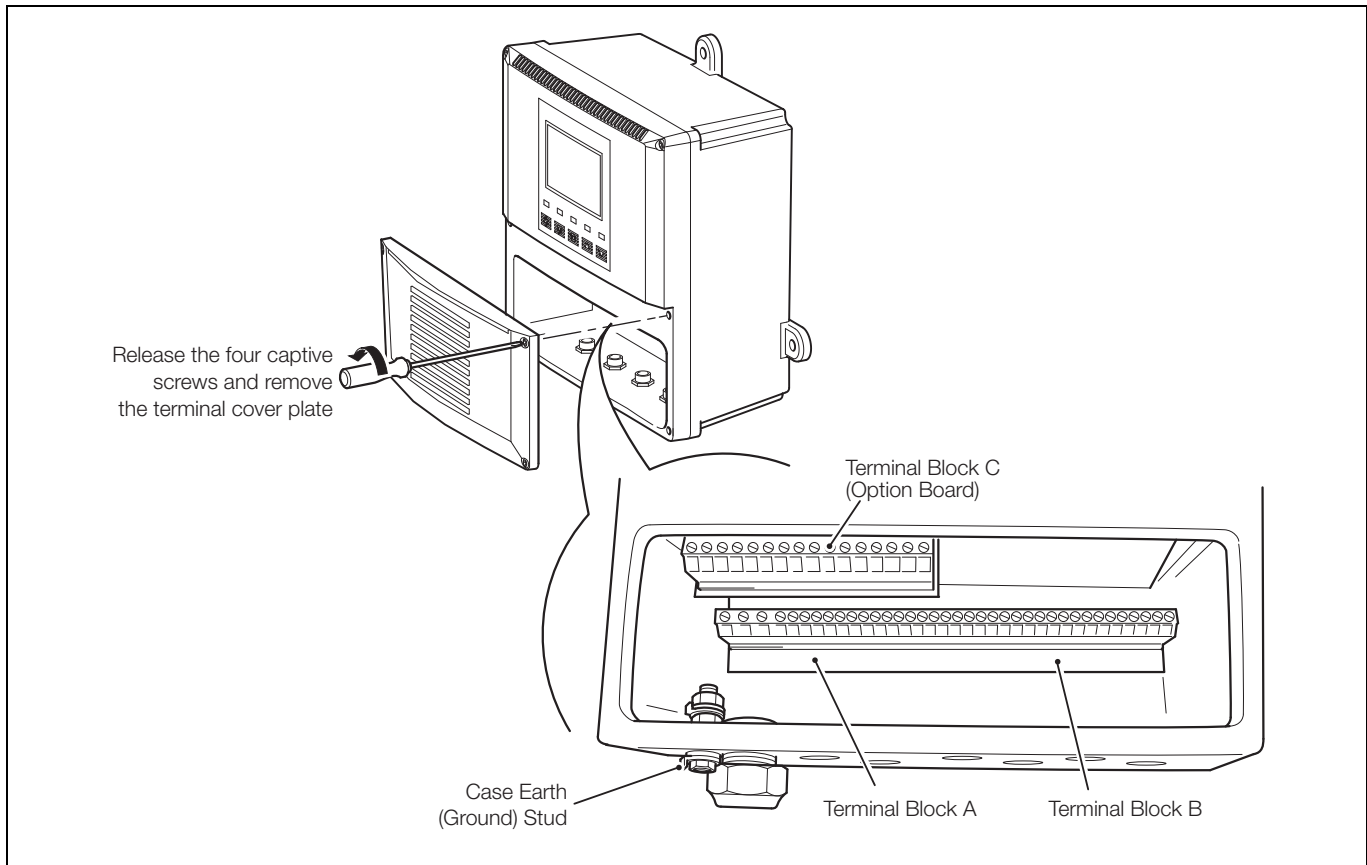

Fig. 6.8 Access to Terminals, Wall-/Pipe-mount Analyzer

Note. When refitting the terminal cover plate, tighten the captive screws to a torque of 0.40 Nm (3.5 lbf. in.)

6.4.2 Connections – Fig. 6.9

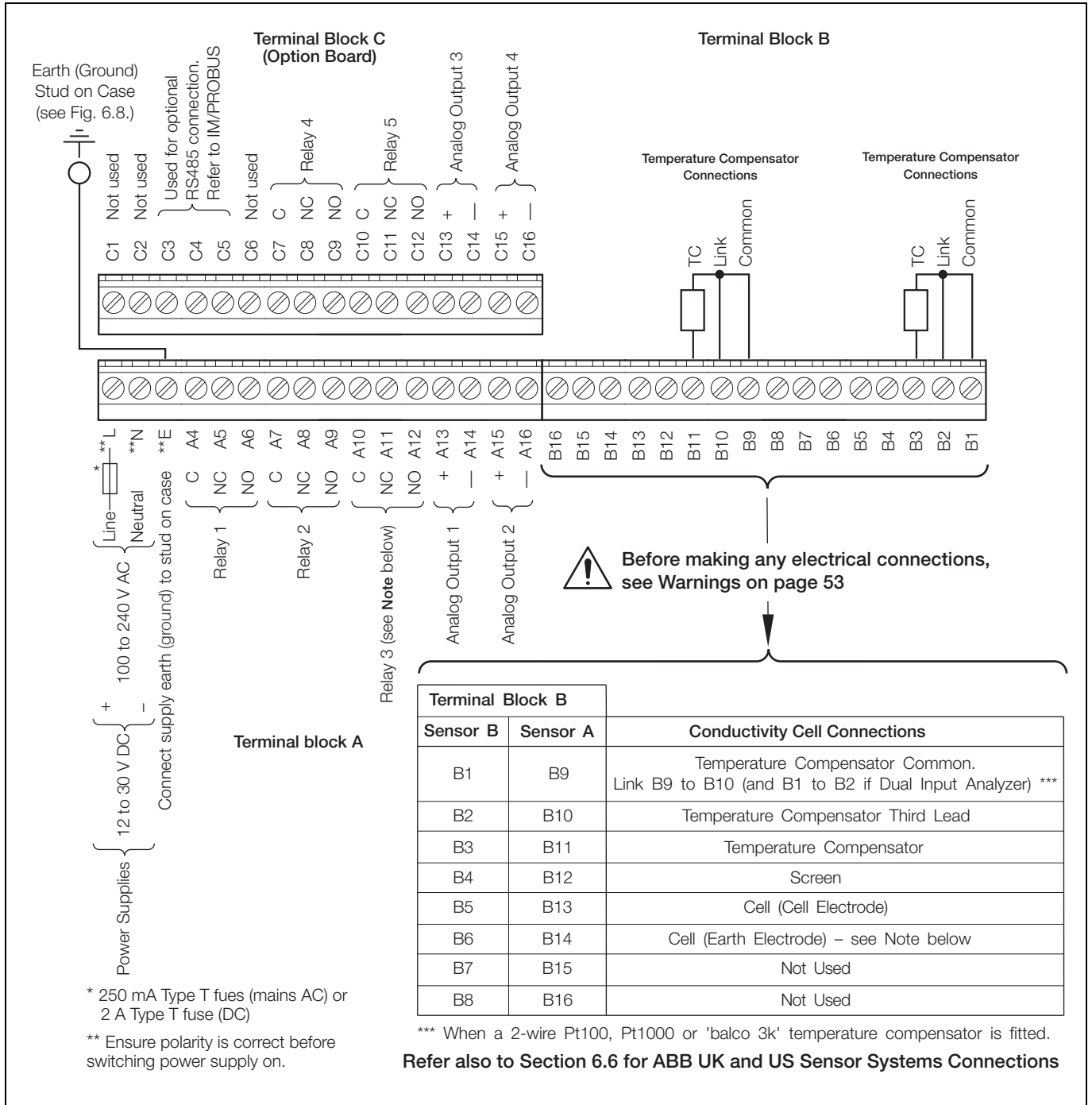

Fig. 6.9 Connections, Wall-/Pipe-mount Analyzer

Note.

- When connecting non-metal conductivity cells or metal conductivity cells that are isolated from earth (ground), e.g. mounted in plastic pipework, link Terminal B14 (and Terminal B6 if dual input analyzer) to the earth (ground) stud on the analyzer case – see Fig. 6.8.
- When connecting earthed (grounded) metal conductivity cells, ensure that the cell earth (ground) and the analyzer earth (ground) stud are at the same potential.
- Tighten the terminal screws to a torque of 0.60 Nm (5.3 lbf. in.).

6.5 Panel-mount Analyzer Connections

6.5.1 Access to Terminals – Fig. 6.10

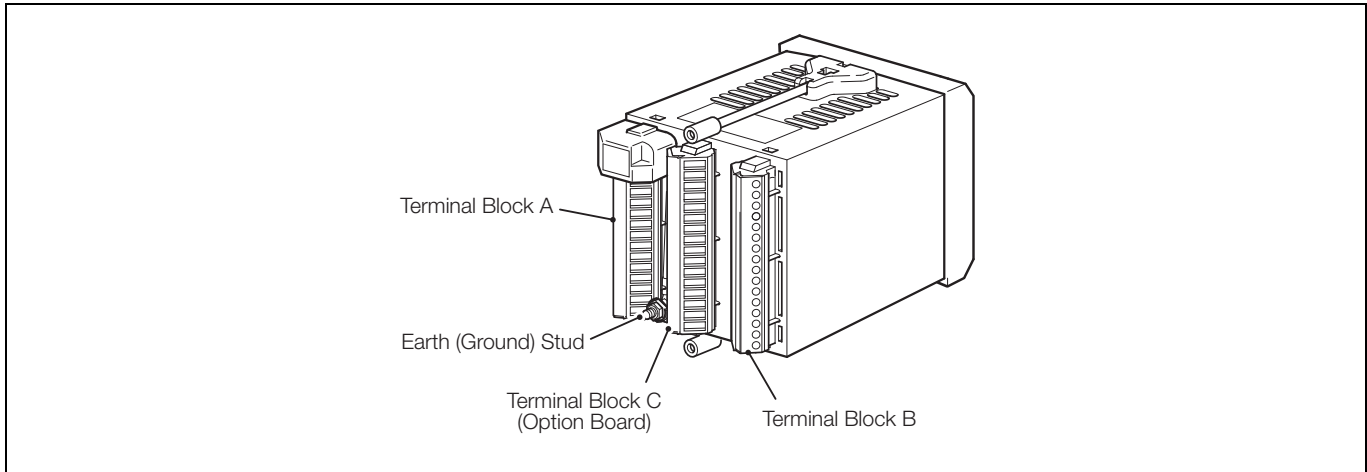

Fig. 6.10 Access to Terminals, Panel-mount Analyzers

6.5.2 Connections – Fig. 6.11

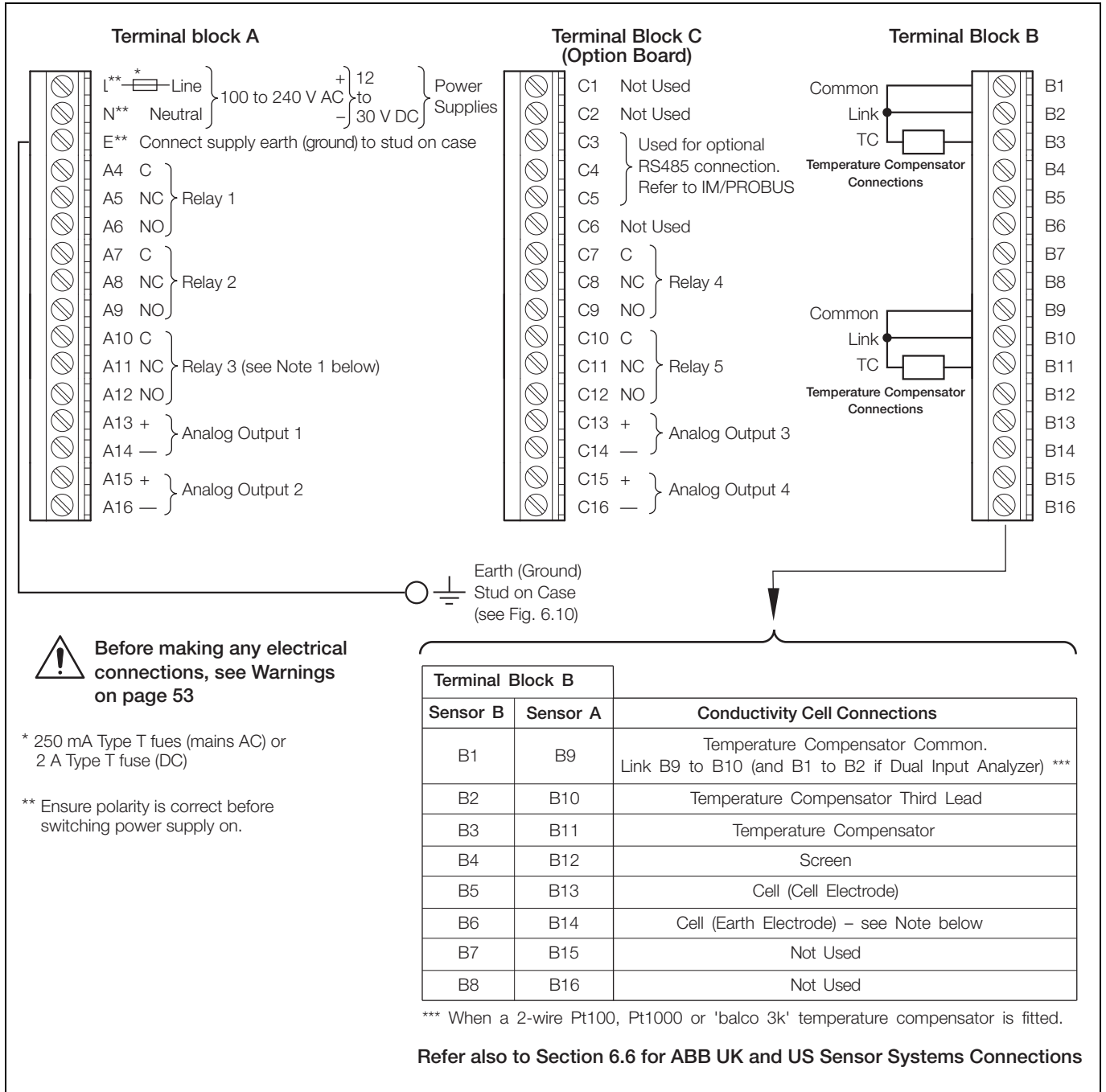

Fig. 6.11 Connections, Panel-mount Analyzers

Note.

- When connecting non-metal conductivity cells or metal conductivity cells that are isolated from earth (ground), e.g. mounted in plastic pipework, link Terminal B14 (and Terminal B6 if dual input analyzer) to the earth (ground) stud on the analyzer case – see Fig. 6.10.
- When connecting earthed (grounded) metal conductivity cells, ensure that the cell earth (ground) and the analyzer earth (ground) stud are at the same potential.
- Tighten the terminal screws to a torque of 0.60 Nm (5.3 lbf. in.).

6.6 ABB Conductivity Sensor Systems Connections – Tables 6.1 to 6.3

Terminal Block B		Cable Colors		
Sensor B	Sensor A	Cable 0233-820	Cable 0233-811 (Conductivity Cell)	Cable 0233-819 (Temperature Compensator)
B1	B9	Green/Yellow	–	Green/Yellow
B2	B10	Blue	–	Blue
B3	B11	Brown	–	Brown
B4	B12	Two Screens	Braid/Screen	–
B5	B13	Red	White	–
B6	B14	Black	Black	–
B7	B15	Not Used	Not Used	Not Used
B8	B16	Not Used	Not Used	Not Used

Table 6.1 Conductivity Cell Connections – Cable Detached, Models 2045 and 2077 (and Models 2078 and 2085 with Plug and Socket)

Terminal Block B		Cable Colors
Sensor B	Sensor A	
B1	B9	Green
B2	B10	Link B2 to B1 (and Link B10 to B9 if Dual Input Analyzer)
B3	B11	Yellow
B4	B12	–
B5	B13	Red
B6	B14	Blue
B7	B15	Not Used
B8	B16	Not Used

Table 6.2 Conductivity Cell Connections – Cable Attached, Models 2025, 2078 and 2077

Terminal Block B		Cable Colors
Sensor B	Sensor A	
B1	B9	Blue
B2	B10	Link B2 to B1 (and Link B10 to B9 if Dual Input Analyzer)
B3	B11	Yellow
B4	B12	Dark Green
B5	B13	Green
B6	B14	Black
B7	B15	Not Used
B8	B16	Not Used

Table 6.3 Conductivity Cell Connections – TB2 Series

7 Calibration

Note.

- The analyzer is calibrated by the Company prior to dispatch and the Factory Settings pages are protected by an access code.
- Routine recalibration is not necessary – high stability components are used in the analyzer's input circuitry and, once calibrated, the Analog-to-Digital converter chip self-compensates for zero and span drift. It is therefore unlikely that the calibration will change over time.
- Do Not attempt recalibration without first contacting ABB.
- Do Not attempt recalibration unless the input board has been replaced or the Factory Calibration tampered with.
- Prior to attempting recalibration, test the analyzer's accuracy using suitably calibrated test equipment – see Section 7.1, page 61 and see Section 7.2, page 61.

7.1 Equipment Required

1. Decade resistance box (conductivity cell input simulator): 0 to 10k Ω (in increments of 0.1 Ω), accuracy $\pm 0.1\%$.
2. Decade resistance box (Pt100/Pt1000 temperature input simulator): 0 to 1k Ω (in increments of 0.01 Ω), accuracy $\pm 0.1\%$.
3. Digital milliammeter (current output measurement): 0 to 20mA.

Note. Resistance boxes have an inherent residual resistance that may range from a few m Ω up to 1 Ω . This value must be taken into account when simulating input levels, as should the overall tolerance of the resistors within the boxes.

7.2 Preparation

1. Switch off the supply and disconnect the conductivity cell(s), temperature compensator(s) and current output(s) from the analyzer's terminal blocks.

Sensor A – Fig. 7.1:

- a. Link terminals B9 and B10.
- b. Connect one terminal of the 0 to 10k Ω decade resistance box to B13 and the other terminal to B14 to simulate the conductivity cell. Connect the decade resistance box earth to B12.
- c. Connect one terminal of the 0 to 1k Ω decade resistance box to B9 and the other terminal to B11 to simulate the Pt100/Pt1000.

Sensor B (dual input analyzers only) – Fig. 7.1:

- a. Link terminals B1 and B2.
 - b. Connect one terminal of the 0 to 10k Ω decade resistance box to B5 and the other terminal to B6 to simulate the conductivity cell. Connect the decade box resistance earth to B4.
 - c. Connect one terminal of the 0 to 1k Ω decade resistance box to B1 and the other terminal to B3 to simulate the Pt100/Pt1000.
3. Connect the milliammeter to the analog output terminals.
 4. Switch on the supply and allow ten minutes for the circuits to stabilize.
 5. Select the **FACTORY SETTINGS** page and carry out Section 7.3.

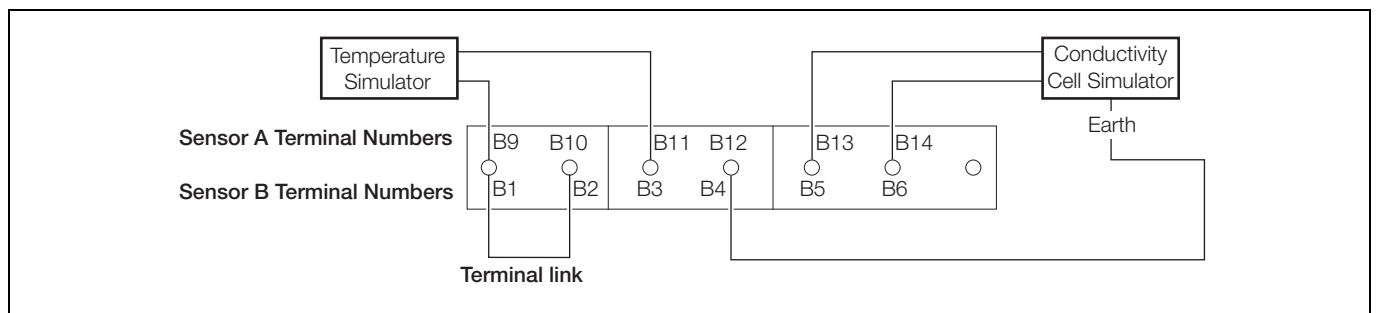

Fig. 7.1 Analyzer Terminal Links and Decade Resistance Box Connections

7.3 Factory Settings

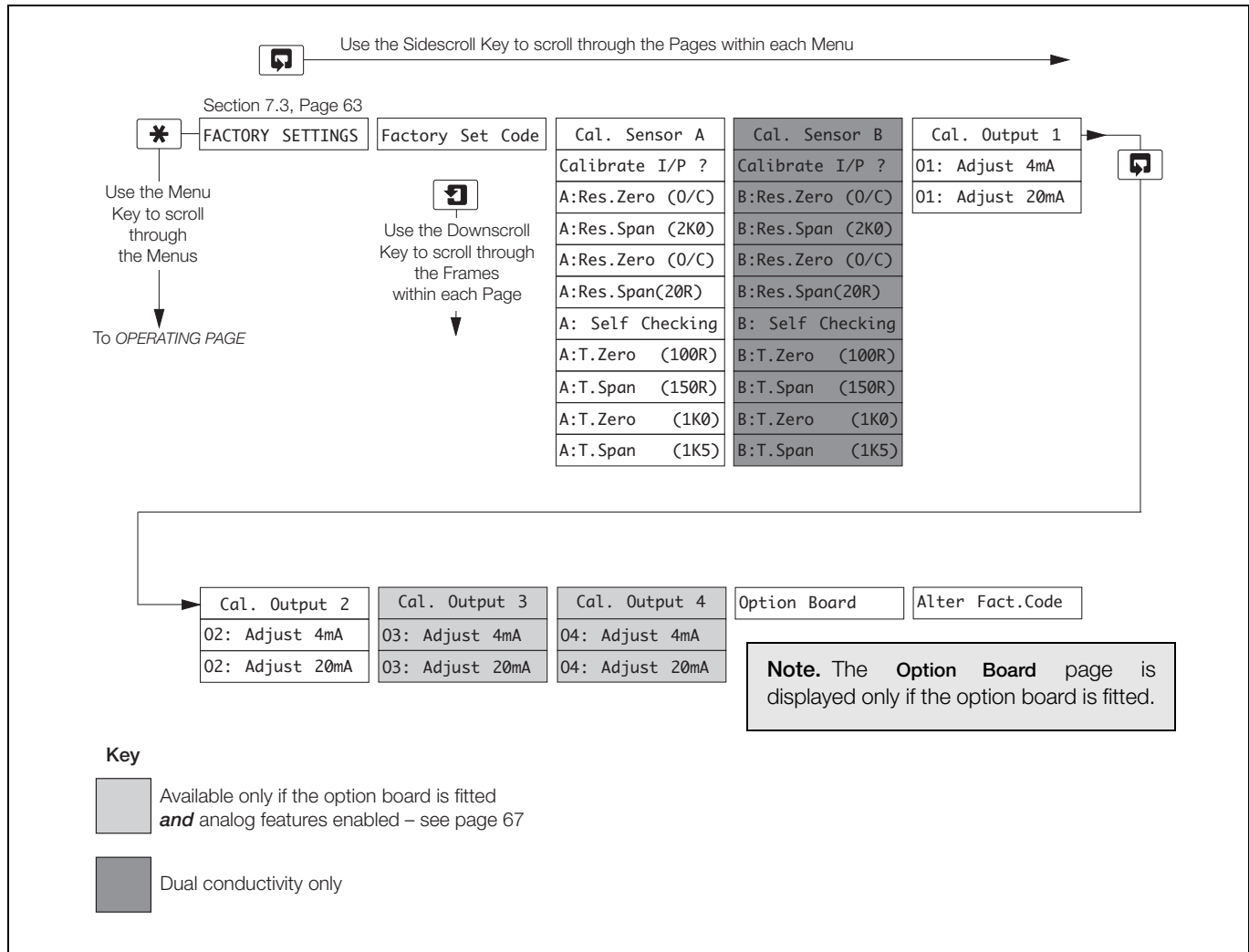
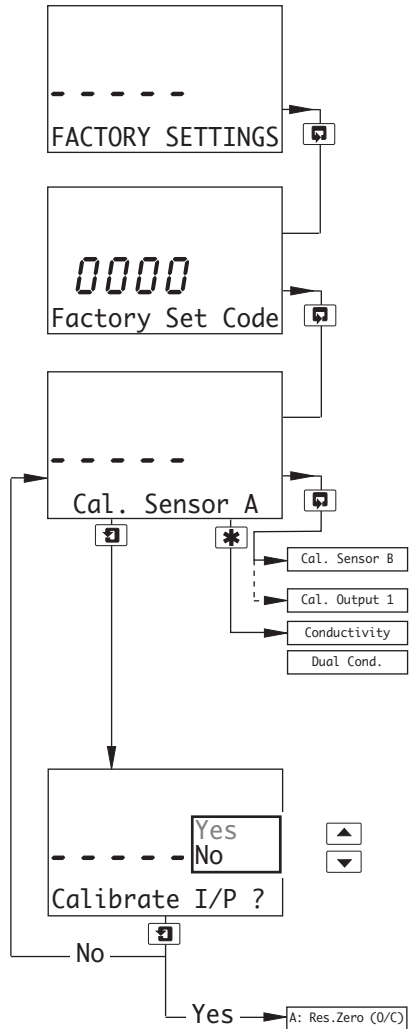

Fig. 7.2 Overall Factory Settings Chart



Factory Settings Access Code

Enter the required code number (between 0000 and 19999) to gain access to the factory settings. If an incorrect value is entered, access to subsequent frames is prevented and the display reverts to the top of the page.

Calibrate Sensor A

Note. The values in the display lines for sensor calibration are shown only as examples – the actual values obtained will differ.

Sensor B calibration (dual input analyzers only) is identical to Sensor A calibration.

Single input analyzers only – see page 66.

} *Operating Page* – see Section 2.3, page 6.

Calibrate Input for Sensor A ?

If calibration is required select **Yes** otherwise select **No**.

Note. To abort calibration, press the **F** key again at any time before calibration is complete – see next page.

Continued on next page.

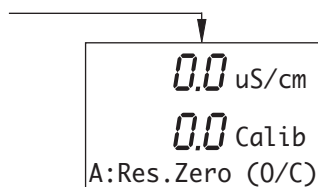

Resistance Zero (Open Circuit)

Open circuit the cell simulator.

The display advances automatically to the next step once a stable and valid value is recorded.

Note. The upper 7-segment display shows the measured conductivity. Once the signal is within range the lower 7-segment display shows the same value and **Calib** is displayed to indicate that calibration is in progress.

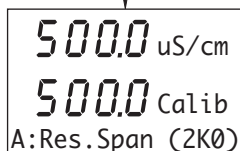

Resistance Span (2k0)

Set the cell simulator to 2kΩ.

The display advances automatically to the next step once a stable and valid value is recorded.

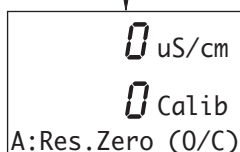

Resistance Zero (Open Circuit)

Open circuit the cell simulator.

The display advances automatically to the next step once a stable and valid value is recorded.



Continued on next page.

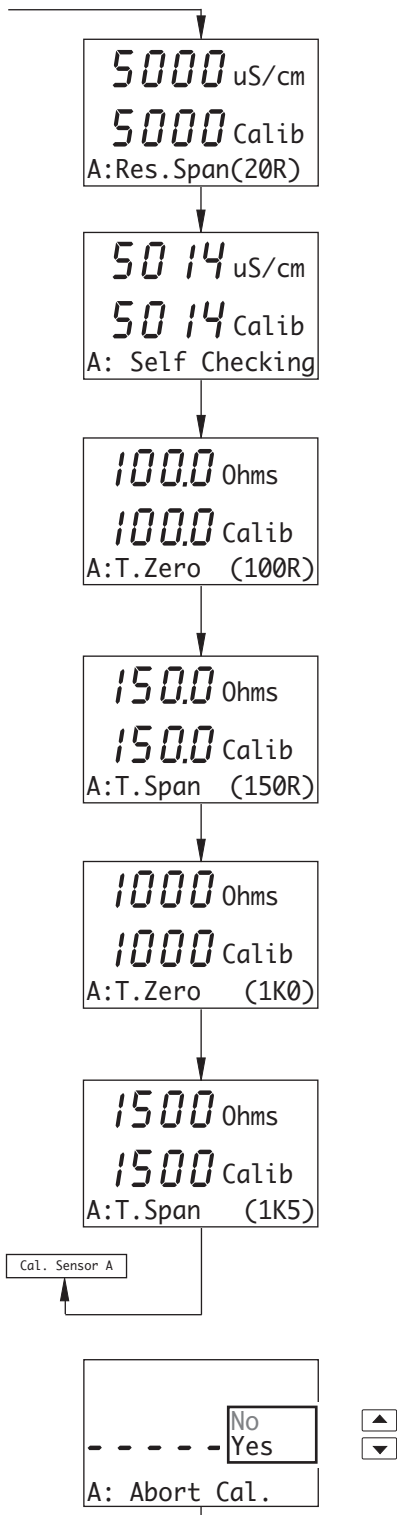

Resistance Span (20R)

Set the cell simulator to 20Ω.

The display advances automatically to the next step once a stable and valid value is recorded.

Self Checking

The analyzer calibrates the internal reference resistance automatically to compensate for changes in ambient temperatures.

The display advances automatically to the next step once a stable and valid value is recorded.

Temperature Zero (100R)

Set the temperature simulator to 100Ω.

The display advances automatically to the next step once a stable and valid value is recorded.

Temperature Span (150R)

Set the temperature simulator to 150Ω.

The display advances automatically to the next step once a stable and valid value is recorded.

Temperature Zero (1k0)

Set the temperature simulator to 1kΩ.

The display advances automatically to the next step once a stable and valid value is recorded.

Temperature Span (1k5)

Set the temperature simulator to 1.5kΩ.

The display returns automatically to **Cal. Sensor A** once a stable and valid value is recorded.

Abort Calibration

Select **Yes** or **No**

Yes selected:

- before completion of **A: Self Checking** frame – calibration advances to **A:T.Zero (100R)** and continues.
- after completion of **A: Self Checking** frame – the display returns to the **Calibrate Sensor A** page.

No selected – calibration continues from the point at which the **[F1]** key was pressed.

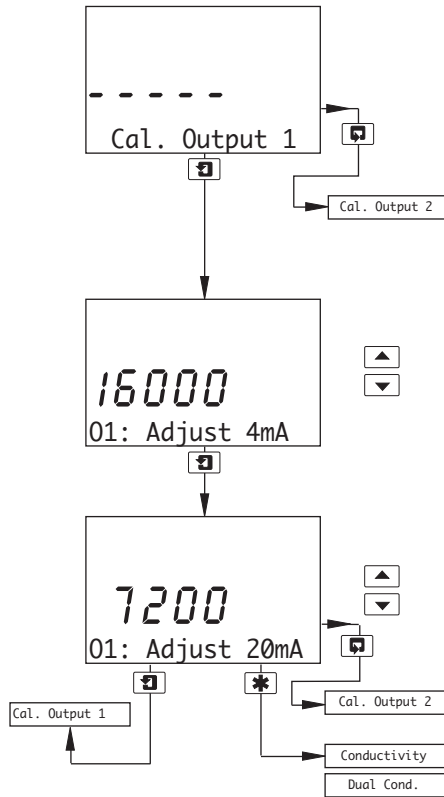

Calibrate Output 1

Note. When adjusting the 4 and 20mA output values, the display reading is unimportant and is used only to indicate that the output is changing when the ▲ and ▼ keys are pressed.

See below.

Adjust 4mA

Use the ▲ and ▼ keys to set the milliammeter reading to 4mA.

Note. The analog output range selected in **Configure Outputs** (Section 5.5) does not affect the reading.

Adjust 20mA

Use the ▲ and ▼ keys to set the milliammeter reading to 20mA.

Note. The analog output range selected in **Configure Outputs** (Section 5.5) does not affect the reading.

See below.

} *Operating Page* – see Section 2.3, page 6.

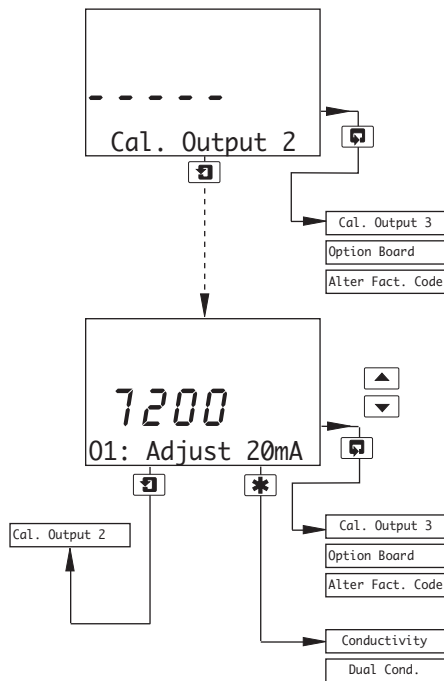

Calibrate Output 2

Note. Output 2 calibration is identical to Output 1 calibration.

Option board fitted **and** analog features enabled – continued on next page.

Option board fitted, additional features disabled – continued on next page.

Option board not fitted – continued on next page.

Option board fitted **and** analog features enabled – continued on next page.

Option board fitted, additional features disabled – continued on next page.

Option board not fitted – continued on next page.

} *Operating Page* – see Section 2.3, page 6.

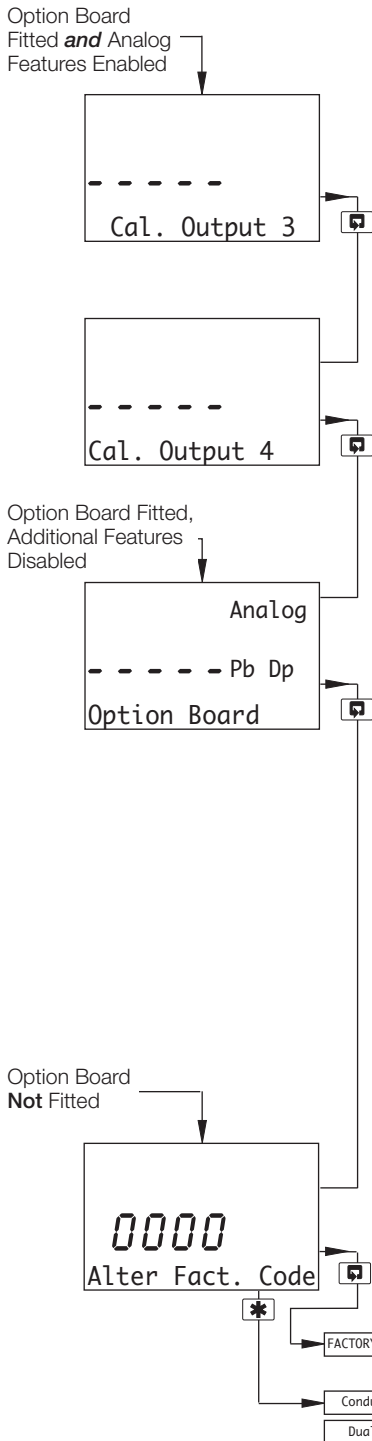

Calibrate Output 3

Notes.

- Output 3 (and Output 4) calibration is applicable only if the option board is fitted **and** analog features enabled – see below.
- Output 3 calibration is identical to Output 2 calibration.

Calibrate Output 4

Note. Output 4 calibration is identical to Output 3 calibration.

Configure Option Board

Notes.

- This parameter is displayed only if an option board is fitted.
- The software detects if an option board is fitted but cannot detect the additional features available.
- If an option board is fitted, the correct selection must be made below to enable use of the available features. If an incorrect selection is made, the software menus and frames associated with that option are displayed in the Operating and Configuration pages but the features do not work.

Use the ▲ and ▼ keys to enable the features for the type of option board(s) fitted:

- Analog** – Analog features enabled (comprising two additional analog outputs, two additional alarm relays, clock and logbook facility).
- Pb Dp** – Profibus-DP digital communications features enabled.
- Analog + Pb Dp** – Both analog and Profibus-DP features enabled.

Alter Factory Code

Set the factory settings access code to a value between 0000 and 19999.

FACTORY SETTINGS Return to main menu.

Conductivity
 Dual Cond. } *Operating Page* – see Section 2.3, page 6.

8 Simple Fault Finding

8.1 Error Messages

If erroneous or unexpected results are obtained the fault may be indicated by an error message – see Table 8.1. However, some faults may cause problems with analyzer calibration or give discrepancies when compared with independent laboratory measurements.

Error Message	Possible Cause
A: FAULTY Pt100 A: FAULTY Pt1000	Temperature compensator/associated connections for Sensor A are either open circuit or short circuit.
B: FAULTY Pt100 B: FAULTY Pt1000	Temperature compensator/associated connections for Sensor B are either open circuit or short circuit.
BELOW COMP RANGE	If Temp. Comp. is set to NH3 (see Section 5.3, page 21), the indicated conductivity value flashes if the measured conductivity of the sample falls below the accurate temperature compensation range. If accurate readings are required below this value, set Temp. Comp. to UPW .
BEFORE CAT. HIGH	The pre-set conductivity value before the cation resin column has been exceeded – see Appendix A.3, page 75.
BEFORE CAT. LOW	The conductivity value before the cation resin column has fallen below the acceptable value for reliable readings when inferred pH is selected – see Appendix A.3, page 75.
AFTER CAT. HIGH	The conductivity value after the cation resin column has exceeded the programmed limit – see Appendix A.3, page 75.
Infr. pH invalid	The calculated (inferred) pH is either: outside the range 7.00 to 10.00pH if NH3 temperature compensation (for a NH3 dosed sample) is selected (see Section 5.3, page 21) or outside the range 7.00 to 11.00pH if NaOH temperature compensation (for a NaOH dosed sample) is selected (see Section 5.3, page 21) Note. In the latter case, the calculation becomes invalid if the after-cation conductivity value, multiplied by 3, is greater than the before-cation value.

Table 8.1 Error Messages

8.2 No Response to Conductivity Changes

The majority of problems are associated with the conductivity cell which must be cleaned as an initial check. It is also important that all program parameters have been set correctly and have not been altered inadvertently – see Section 5, page 19.

If the above checks do not resolve the fault:

1. Check the analyzer responds to a resistance input. Disconnect the conductivity cell cable and connect a suitable resistance box directly to the analyzer input – see Section 7.2, page 61. Select the CONFIG. SENSORS page and set Temp.Comp. to None – see Section 5.3, page 21. Check the analyzer displays the correct values as set on the resistance box – see Table 8.2 or use the expression:

$$R = \frac{K \times 10^6}{G}$$

Where: R = resistance
 K = cell constant
 G = conductivity

Conductivity µS cm ⁻¹ (G)	Cell Constant (K)		
	0.05	0.1	1.0
	Resistance (R)		
0.055	909.091kΩ	–	–
0.1	500kΩ	1MΩ	–
0.5	100kΩ	200kΩ	–
1	50kΩ	100kΩ	1MΩ
5	10kΩ	20kΩ	200kΩ
10	5kΩ	10kΩ	100kΩ
50	1kΩ	2kΩ	20kΩ
100	500Ω	1kΩ	10kΩ
500	100Ω	200Ω	2kΩ
1000	–	100Ω	1kΩ
5,000	–	–	200Ω
10,000	–	–	100Ω

Table 8.2 Conductivity Readings for Resistance Inputs

Failure to respond to the input indicates a fault with the analyzer which must be returned to the Company for repair. A response, but with incorrect readings, usually indicates an electrical calibration problem. Re-calibrate the analyzer as detailed in Section 7.3.

2. If the response in a) is correct, reconnect the conductivity cell cable and connect the resistance box to the cell end. Check the analyzer displays the correct values as set on the resistance box in this configuration.

If the analyzer passes check a) but fails check b), check the cable connections and condition. If the response for both checks is correct, replace the conductivity cell.

8.3 Checking the Temperature Input

Check the analyzer responds to a temperature input. Disconnect the Pt100/Pt1000 leads and connect a suitable resistance box directly to the analyzer inputs – see Section 7.2, page 61. Check the analyzer displays the correct values as set on the resistance box – see Table 8.3.

Temperature		Input Resistance (Ω)	
°C	°F	Pt100	Pt1000
0	32	100.00	1000.0
10	50	103.90	1039.0
20	68	107.79	1077.9
25	77	109.73	1097.3
30	86	111.67	1116.7
40	104	115.54	1155.4
50	122	119.40	1194.0
60	140	123.24	1232.4
70	158	127.07	1270.7
80	176	130.89	1308.9
90	194	134.70	1347.0
100	212	138.50	1385.0
130.5	267	150.00	1500.0

Table 8.3 Temperature Readings for Resistance Inputs

Incorrect readings usually indicate an electrical calibration problem. Re-calibrate the analyzer as detailed in Section 7.3.

9 Specification

Conductivity – AX41x and AX45x

Range

Programmable 0 to 0.5 to 0 to 10,000 $\mu\text{S cm}^{-1}$
(with various cell constants)

Minimum span

10 x cell constant

Maximum span

10,000 x cell constant

Units of measure

$\mu\text{S cm}^{-1}$, $\mu\text{S m}^{-1}$, mS cm^{-1} , mS m^{-1} , $\text{M}\Omega\text{-cm}$ and TDS

Accuracy

Better than $\pm 0.01\%$ of span (0 to 100 $\mu\text{S cm}^{-1}$)

Better than $\pm 1\%$ of reading (10,000 $\mu\text{S cm}^{-1}$)

Operating temperature range

-10 to 200°C (14 to 392°F)

Temperature compensation

-10 to 200°C (14 to 392°F)

Temperature coefficient

Programmable 0 to 5%/°C and fixed temperature compensation curves (programmable) for acids, neutral salts and ammonia

Temperature sensor

Programmable Pt100 or Pt1000

Reference Temperature

25°C (77°F)

Calculated variables – AX411

Ratio	0 to 19,999
Difference	0 to 10,000 $\mu\text{S cm}^{-1}$
Percent passage or rejection	0 to 100.0%
Total dissolved solids	0 to 8,000 ppm
Inferred pH	7.0 to 10.0pH (NH ₃ -dosed systems) 7.0 to 11.0pH (NaOH-dosed systems)*

* pH calculation according to the appendix in the VGB directive 450L, 1988.

pH /Redox (ORP) – AX416

Inputs

pH or mV input and solution earth

Temperature sensor Pt100, Pt1000 or Balco 3k

Enables connection to glass or enamel pH and reference sensors and Redox (ORP) sensors

Input resistance

Glass $> 1 \times 10^{13}\Omega$

Reference $1 \times 10^{13}\Omega$

Range

-2 to 16pH or -1200 to +1200mV

Minimum span

Any 2pH span or 100mV

Resolution

0.01pH

Accuracy

0.01pH

Temperature compensation modes

Automatic or manual Nernstian compensation

Range -10 to 200°C (14 to 392°F)

Process solution compensation with configurable coefficient

Range -10 to 200°C (14 to 392°F)

adjustable -0.05 to +0.02%/°C (-0.02 to +0.009%/°F)

Temperature sensor

Programmable Pt100, Pt1000 or Balco 3k Ω

Calibration Ranges

Check value (zero point)

0 to 14pH

Slope

Between 40 and 105% (low limit user configurable)

Electrode Calibration Modes

Calibration with auto-stability checking

Automatic 1 or 2 point calibration selectable from:

ABB

DIN

Merck

NIST

US Tech

2 x User-defined buffer tables for manual entry,

2-point calibration or one-point process calibration

Display

Type

Dual 5-digit, 7-segment backlit LCD

Information

16-character, single line dot-matrix

Energy-saving function

Backlit LCD configurable as ON or Auto-Off after 60s

Logbook*

Electronic record of major process events and calibration data

Real-time clock*

Records time for logbook and auto-manual functions

*Available if option board is fitted.

Relay Outputs – On/Off

Number of relays

Three supplied as standard or five with option board fitted

Number of set points

Three supplied as standard or five with option board fitted

Set point adjustment

Configurable as normal or failsafe high/low or diagnostic alert

Hysteresis of reading

Programmable 0 to 5% in 0.1% increments

Delay

Programmable 0 to 60s in 1s intervals

Relay contacts

Single-pole changeover

Rating 5A, 115/230V AC, 5A DC

Insulation

2kV RMS contacts to earth/ground

Analog Outputs

Number of current outputs (fully isolated)

Two supplied as standard or four with option board fitted

Output range

0 to 10mA, 0 to 20mA or 4 to 20mA

Analog output programmable to any value between 0 and 22mA to indicate system failure

Accuracy

$\pm 0.25\%$ FSD, $\pm 0.5\%$ of reading (whichever is the greater)

Resolution

0.1% at 10mA 0.05% at 20mA

Maximum load resistance

750 Ω at 20mA

Configuration

Can be assigned to either measured variable or either sample temperature

Digital Communications

Communications

Profibus DP (with option board fitted)

Control Function – AX410 Only

Controller Type

P, PI, PID (configurable)

Control Outputs

Analog

Current output control (0 to 100%)

Time proportioning cycle time

1.0 to 300.0s, programmable in increments of 0.1s

Pulse frequency

1 to 120 pulses per minute, programmable in increments of 1 pulse per minute

Controller action

Direct or reverse

Proportional band

0.1 to 999.9%, programmable in increments of 0.1%

Integral action time (Integral reset)

1 to 7200s, programmable in increments of 1s (0 = Off)

Derivative

0.1 to 999.9s in increments of 0.1s – only available for single set point control

Auto/Manual

User-programmable

Access to Functions

Direct keypad access

Measurement, maintenance, configuration, diagnostics or service functions

Performed without external equipment or internal jumpers

Sensor Cleaning Function – AX416 Only

Configurable cleaning action relay contact

Continuous

Pulse in 1s on and off times

Frequency

5 minutes to 24 hours, programmable in 15 minute increments up to 1 hour then in 1 hour increments for 1 to 24 hours

Duration

15s to 10 minutes, programmable in 15s increments up to 1 minute then in 1 minute increments up to 10 minutes

Recovery period

30s to 5 minutes, programmable in 30s increments

Mechanical Data

Wall-/Pipe-mount versions

IP65 (not evaluated under UL certification)

Dimensions 192mm high x 230mm wide x 94mm deep
(7.56 in. high x 9.06 in. wide x 3.7 in. deep)

Weight 1kg (2.2 lb)

Panel-mount versions

IP65 (front only)

Dimensions 96mm x 96mm x 162mm deep
(3.78 in. x 3.78 in. x 6.38 in. deep)

Weight 0.6kg (1.32 lb)

Cable Entry Types

Standard 5 or 7 x M20 cable glands

North American 7 x knockouts suitable for 1/2 in. Hubble gland

Power Supply

Voltage requirements

100 to 240 V AC 50/60 Hz
(90 V Min. to 264 V Max. AC)

12 to 30 V DC

Power consumption

10 W

Insulation

Mains to earth (line to ground) 2kV RMS

Environmental Data

Operating temperature limits

-20 to 55°C (-4 to 131°F)

Storage temperature limits

-25 to 75°C (-13 to 167°F)

Operating humidity limits

Up to 95%RH non condensing

EMC

Emissions and immunity

Meets requirements of:

EN61326 (for an industrial environment)

EN50081-2

EN50082-2

Approvals, Certification and Safety

Safety approval

UL

CE Mark

Covers EMC & LV Directives (including latest version EN 61010)

General safety

EN61010-1

Overvoltage Class II on inputs and outputs

Pollution category 2

Languages

Languages configurable:

English

French

German

Italian

Spanish

DS/AX4CO-EN Rev. M

Appendix A – Calculations

A.1 Automatic Temperature Compensation

The conductivities of electrolytic solutions are influenced considerably by temperature variations. Thus, when significant temperature fluctuations occur, it is general practice to correct automatically the measured, prevailing conductivity to the value that would apply if the solution temperature were 25°C, the internationally accepted standard.

Most commonplace, weak aqueous solutions have temperature coefficients of conductance of the order of 2% per °C (i.e. the conductivities of the solutions increase progressively by 2% per °C rise in temperature); at higher concentrations the coefficient tends to become less.

At low conductivity levels, approaching that of ultra-pure water, dissociation of the H₂O molecule takes place and it separates into the ions H⁺ and OH⁻. Since conduction occurs only in the presence of ions, there is a theoretical conductivity level for ultra-pure water which can be calculated mathematically. In practice, correlation between the calculated and actual measured conductivity of ultra-pure water is very good.

Fig. A.1 shows the relationship between the theoretical conductivity for ultra-pure water and that of high purity water (ultra-pure water with a slight impurity), when plotted against temperature. The figure also illustrates how a small temperature variation considerably changes the conductivity. Subsequently, it is essential that this temperature effect is eliminated at conductivities approaching that of ultra-pure water, in order to ascertain whether a conductivity variation is due to a change in impurity level or in temperature.

For conductivity levels above 1µS cm⁻¹, the generally accepted expression relating conductivity and temperature is:

$$G_t = G_{25} [1 + \alpha (t - 25)]$$

- Where: G_t = conductivity at temperature t°C
 G_{25} = conductivity at the standard temperature (25°C)
 α = impurity temperature coefficient
 α = temperature coefficient per °C

At conductivities between 1µS cm⁻¹ and 1,000µS cm⁻¹, α lies generally between 0.015/°C and 0.025/°C. When making temperature compensated measurements, a conductivity analyzer must carry out the following computation to obtain G_{25} :

$$G_{25} = \frac{G_t}{[1 + \alpha (t - 25)]}$$

However, for ultra-pure water conductivity measurement, this form of temperature compensation alone is unacceptable since considerable errors exist at temperatures other than 25°C.

At high purity water conductivity levels, the conductivity/temperature relationship is made up of two components: the first component, due to the impurities present, generally has a temperature coefficient of approximately 0.02/°C; and the second, which arises from the effect of the H⁺ and OH⁻ ions, becomes predominant as the ultra-pure water level is approached.

Consequently, to achieve full automatic temperature compensation, the above two components must be compensated for separately according to the following expression:

$$G_{25} = \frac{G_t - G_{upw}}{[1 + \alpha (t - 25)]} + 0.055$$

- Where: G_t = conductivity at temperature t°C
 G_{upw} = ultra-pure water conductivity at temperature t°C
 α = impurity temperature coefficient
 0.055 = conductivity in µS cm⁻¹ of ultra-pure water at 25°C

The expression is simplified as follows:

$$G_{25} = \frac{G_{imp}}{[1 + \alpha (t - 25)]} + 0.055$$

- Where: G_{imp} = impurity conductivity at temperature t°C

The conductivity analyzer utilizes the computational ability of a microprocessor to achieve ultra-pure water temperature compensation using only a single platinum resistance thermometer and mathematically calculating the temperature compensation required to give the correct conductivity at the reference temperature.

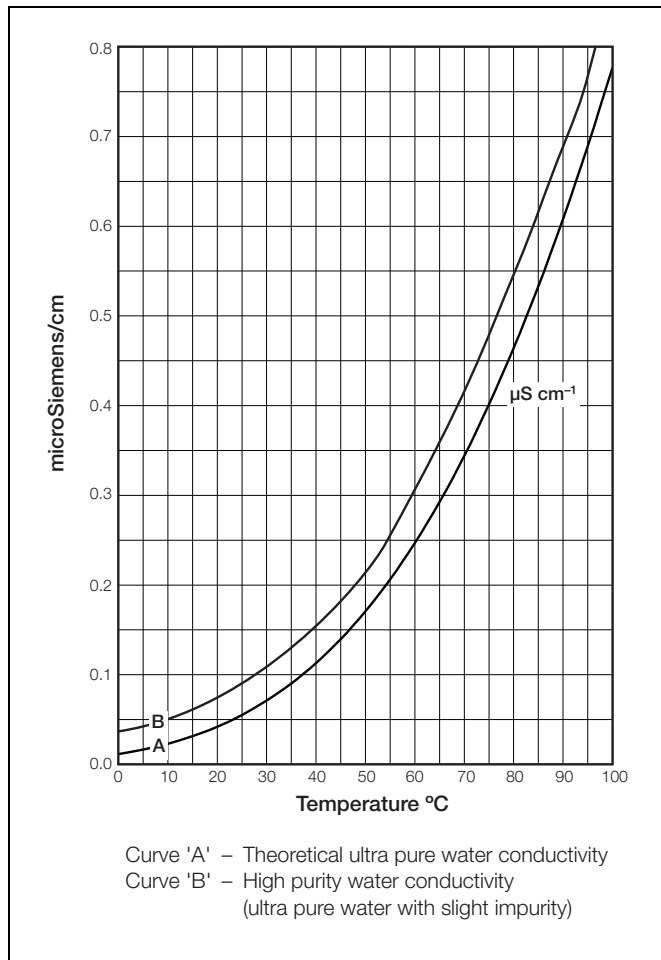

Fig. A.1 Ultra-pure Water Temperature Compensation

A.1.1 Calculation of Temperature Coefficient

The temperature coefficient of a solution can be obtained experimentally by taking non-temperature compensated conductivity measurements at two temperatures and applying the following expression:

$$\alpha = \frac{G_{t2} - G_{t1}}{G_{t1} (t_2 - 25) - G_{t2} (t_1 - 25)}$$

Where: G_{t2} = conductivity measurement at a temperature of $t_2^{\circ}\text{C}$

G_{t1} = conductivity measurement at a temperature of $t_1^{\circ}\text{C}$

One of these measurements could be made at the ambient temperature and the other obtained by heating the sample.

Temperature coefficient (%/°C) = $\alpha \times 100$.

For ultra pure water applications the temperature compensation equation becomes,

$$\alpha = \frac{G_{imp1} - G_{imp2}}{[G_{imp2} (t_1 - 25) - G_{imp1} (t_2 - 25)]}$$

Where: $G_{imp1} = G_{t1} - G_{upw1}$

$G_{imp2} = G_{t2} - G_{upw2}$

A.2 Relationship Between Conductivity and Total Dissolved Solids (TDS) Measurement

The TDS factor (i.e. the relationship between conductivity [$\mu\text{S cm}^{-1}$] and TDS in p.p.m.) is totally dependent on the properties of the solution being measured.

In simple solutions where only one electrolyte is present, the conductivity/TDS ratio can be ascertained easily, e.g. 0.5 in the case of sodium chloride. However, in complex solutions where more than one electrolyte is present, the ratio is not calculated easily and can be reliably determined only by laboratory testing, e.g. precipitation and weighing. The ratio in these cases varies between approximately 0.4 and 0.8, depending on the chemical constituents, (e.g. the ratio for sea water is about 0.6) and is constant only when the chemical ratios remain constant throughout a particular process.

In cases where the TDS factor cannot be determined easily, refer to the supplier of the particular chemical treatment being used.

A.3 Inferred pH Derived from Differential Conductivity

A.3.1 Monitoring on Steam-Raising Plant

For many years, it has been standard practice in power plants to use inferred pH, calculated from before- and after-cation conductivity measurements, to confirm values obtained by direct laboratory or on-line pH measurement.

According to EPRI, IEC and VGB Guidelines, feedwater and boiler water quality can be assessed by measuring the conductivity of samples before and after a cation ion-exchange resin column. Depending on the type of plant and chemical treatment applied, differential conductivity can also give an indication of the pH of the sample.

Both before and after measurements can be made on one dual input conductivity analyzer.

The choice of inferred pH calculation depends on controlled chemical conditions, i.e. whether or not the system is an NH_3 , NH_3+NaCl or NaOH dosed system.

Note.

- If the analyzer is used with a cation resin column, Sensor A must be installed before the column and Sensor B after the column for the correct calculation of inferred pH.
- Both conductivity inputs must be configured as $\mu\text{S cm}^{-1}$ in order to calculate inferred pH.

Warning.

The calculation of inferred pH relies on the strict control of chemical conditions within the NH_3 , NH_3+NaCl or NaOH dosed sample. Contamination with chemical substances other than those with which the sample is dosed introduces significant errors in the inferred pH calculated value and, in the worse case, invalidates the calculation completely. Carbon dioxide in particular has a very adverse affect. Sources of CO_2 contamination include:

- Boiler start-up. CO_2 can be present in the sample for several hours or even days immediately after boiler start-up.

Note. This also applies to 'two shifting' or 'cycling' boilers, i.e. boilers whose full output is required only during peak demand periods.

- Organic compound contamination. Decomposing organic compounds are a source of CO_2 contamination. Organic compound contamination may be caused by break-through from the water treatment plant or from condenser leaks. Formates are also formed when organic compounds decompose; these further increase errors in inferred pH calculation.
- Carbon compound contamination. The use of carbon compound chemical treatments such as carbohydrazide (used as an oxygen scavenger) can contaminate the sample with CO_2 .

Independent pH readings are necessary to confirm that the correct chemical conditions prevail for the accurate calculation of inferred pH.

A.3.2 Monitoring on AVT Systems

For low conductivity feedwater applications, all volatile chemical treatment (AVT) is often applied.

Where cation resin columns are used to remove the effects on the conductivity measurement of volatile ammonia and hydrazine chemical treatment, it is common practice to measure both before- and after-cation conductivity. The sensitivity of the conductivity measurement to chemical treatments is increased by passing the sample through the cation column.

If it is known that a sample contains only one impurity (e.g. ammonia), the conductivity measurement now becomes an indication of the concentration of that impurity and it is then possible to calculate the pH of the sample from the concentration data. The result is referred to as 'inferred pH'.

The maximum after-cation conductivity value is programmable between 0.060 and 10.00 $\mu\text{S cm}^{-1}$ dependent on local conditions. After-cation values above this level generate an **AFTER CAT. HIGH** error message and before-cation values above 25.00 $\mu\text{S cm}^{-1}$ generate a **BEFORE CAT. HIGH** error message. The inferred pH range is 7 to 10pH; values above 10pH generate an **Infr. pH invalid** error message. Refer to Section 8 for description of error messages.

The inferred pH feature can be used on AVT systems only in the following circumstances:

1. On steam raising plant.
2. For boiler chemical treatment such as ammonia and/or hydrazine. In this instance, **A: Temp. Comp.** must be set to **NH3** and **B: Temp. Comp.** must be set to **ACID** – see Section 5.3.
3. Where the after-cation conductivity value is insignificant compared to the before-cation value.

Note. Inferred pH measurement on AVT systems is inappropriate to chemical treatments such as sodium phosphate, sodium hydroxide and morpholine.

A.3.3 Monitoring on AVT Systems with Impurities

Differential conductivity can also give an indication of sample pH on AVT systems where there are low concentrations of ionic impurities present in addition to the volatile alkaline agent (e.g. sodium chloride + ammonia). In this case, the exchange of ammonium and sodium ions within the cation column releases water and hydrochloric acid. The sodium chloride impurity produces a conductivity after the column that is higher than the conductivity before. The dual input analyzer, when used to monitor before- and after-cation conductivities, compensates for this increase and calculates the inferred pH of the incoming sample. The user-configurable, after-cation conductivity alarm can be used to detect unacceptably high levels of impurities in the sample and inform the user of the validity of the inferred pH value.

The calculated inferred pH is proportional to:

$$BC - (AC - 0.055)/R$$

Where: BC = the before column reading

AC = the after column reading

0.055 = the conductivity of pure water at 25°C in $\mu\text{S cm}^{-1}$

R = a ratio factor depending on the BC and AC readings

The maximum after-cation conductivity value is programmable between 0.060 and 25.00 $\mu\text{S cm}^{-1}$ dependent on local conditions. After-cation values above this level generate an **AFTER CAT. HIGH** error message and before-cation values above 25.00 $\mu\text{S cm}^{-1}$ generate a **BEFORE CAT. HIGH** error message. The inferred pH range is 7 to 10pH; values above 10pH generate an **Infr. pH invalid** error message. Refer to Section 8 for description of error messages.

The inferred pH feature can be used on AVT systems with impurities only in the following circumstances:

1. On steam raising plant.
2. For boiler chemical treatment such as ammonia and/or hydrazine. In this instance, **A: Temp. Comp.** must be set to **NH3** and **B: Temp. Comp.** must be set to **ACID** – see Section 5.3.
3. Where the after-cation conductivity value is less than 25.00 $\mu\text{S cm}^{-1}$.

Note. Inferred pH measurement on AVT systems with impurities is inappropriate to chemical treatments such as sodium phosphate, sodium hydroxide and morpholine.

A.3.4 Monitoring on Solid Alkaline Treated Systems

Generally, boiler waters treated with solid alkaline chemicals, for example, sodium hydroxide, have relatively high conductivities. The dual input conductivity analyzer, in conjunction with a cation resin column, can be used to indicate sample pH. If the sample also contains salts (e.g. sodium chloride), the after-cation conductivity reading reflects the acid conductivity released by the salts; the reading is typically three times higher than normal owing to the acid. Hence to derive the concentration and pH of the alkaline agent, one third of the after-cation conductivity increase must be subtracted from the before-column reading. In addition, a factor must be applied for the molar conductivity change of the alkaline agent. The analyzer software applies the following equation:

$$\text{Inferred pH} = 11 + \frac{\log(\text{BC} - \frac{1}{3}\text{AC})}{F}$$

Where: BC = the before column reading

AC = the after column reading

F = molar conductivity change for the
alkaline agent (243 $\mu\text{S cm}^{-1}$ per mmol/l
for sodium hydroxide*)

The maximum after-cation conductivity value is programmable between 1.00 and 100.0 $\mu\text{S cm}^{-1}$ dependent on local conditions. After-cation values above this level generate an **AFTER CAT. HIGH** error message and before-cation values above 100.0 $\mu\text{S cm}^{-1}$ generate a **BEFORE CAT. HIGH** error message. The inferred pH range is 7 to 11pH; values above 11pH generate an **Infr. pH invalid** error message. Refer to Section 8 for description of error messages.

The inferred pH feature can be used on solid alkali treated systems only in the following circumstances:

1. On steam raising plant.
2. For boiler chemical treatment such as sodium hydroxide. In this instance, **A: Temp. Comp.** must be set to **NaOH** and **B: Temp. Comp.** must be set to **ACID** – see Section 5.3, page 21.
3. Where the after-cation conductivity value is less than 100.0 $\mu\text{S cm}^{-1}$.

Note. Inferred pH measurement on solid alkaline treated systems is inappropriate to samples containing sodium phosphate, ammonia or morpholine.

* Refer to Appendix to VGB Guideline VGB-R 450 L.

Appendix B – PID Control

B.1 Single PID Controller – Fig. B.1

The single PID controller is a basic feedback control system using three-term PID control with a local set point.

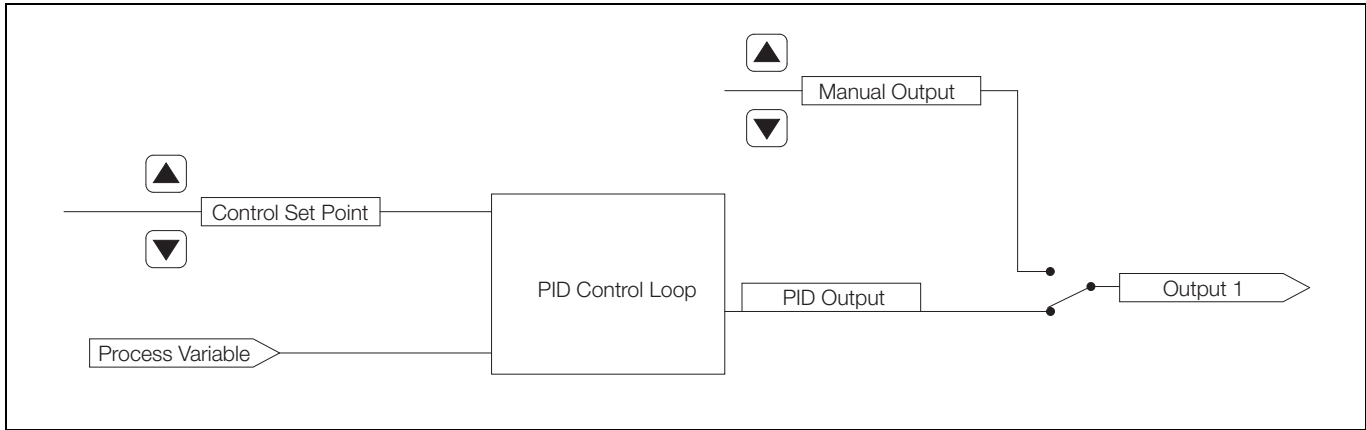

Fig. B.1 Single PID Controller

B.1.1 Reverse Acting Single PID Control – Fig. B.2

Reverse acting control is used when the process conductivity is less than the required output conductivity.

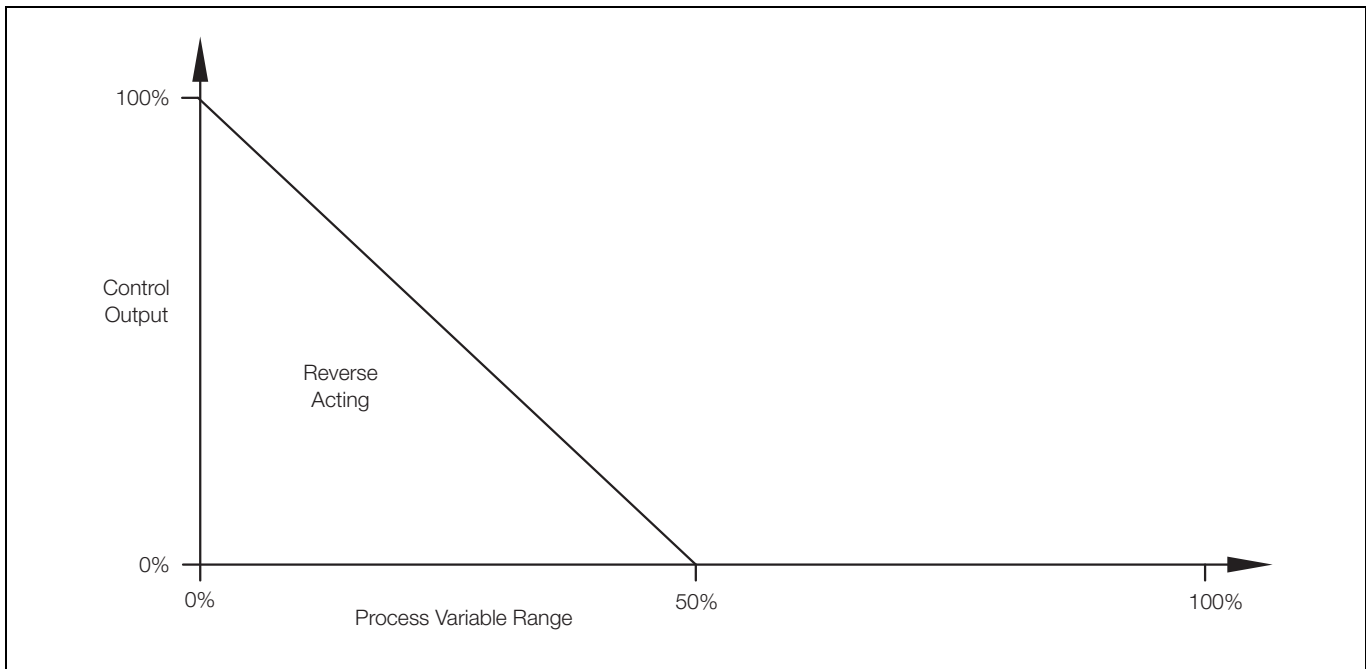

Fig. B.2 Reverse Acting Single PID Control

B.1.2 Direct Acting Single PID Control – Fig. B.3

Direct acting control is used when the process conductivity is greater than the required output conductivity.

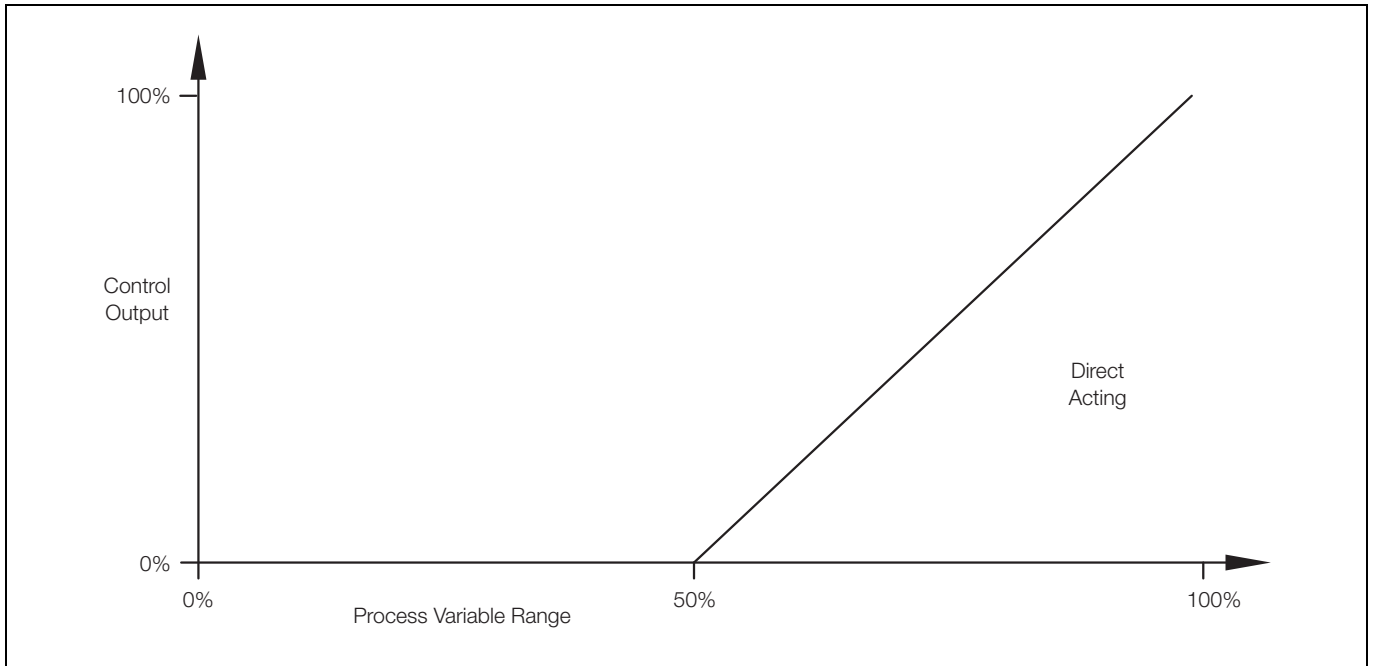

Fig. B.3 Direct Acting Single PID Control

B.2 Output Assignment

The output signal is assignable to either relay 1 (Time or Pulse output type) or analog output 1 (Analog output type).

B.3 Setting Up Three Term (PID) Control Parameters

To enable a process to be controlled satisfactorily, the following conditions must apply:

1. The process must be capable of reaching a natural balance with a steady load.
2. It must be possible to introduce small changes into the system without destroying either the process or the product.

The **Proportional Band** determines the gain of the system. (the gain is the reciprocal of the proportional band setting, e.g. a setting of 20% is equivalent to a gain of 5). If the proportional band is too narrow, the control loop may become unstable and cause the system to oscillate. With proportional band control only, the system normally stabilizes eventually but at a value which is offset from the set point.

The addition of **Integral Action Time** removes the offset but, if set too short, can cause the system to go into oscillation. The introduction of **Derivative Action Time** reduces the time required by the process to stabilize.

B.4 Manual Tuning

Before starting up a new process or changing an existing one:

1. Select the **Config. Control** page and ensure that **Controller** is set to **PID** – see Section 5.8, page 42.
2. Select the **PID Controller** page and set the following:

Proportional Band - 100%
Integral Time - 0 (off) - see Section 5.8.1
Derivative Time - 0 (off)

Note.

- If the system goes into oscillation with increasing amplitude (Fig. B.4 Mode B), reset the proportional band to 200%. If oscillation continues as in Mode B, increase the proportional band further until the system ceases to oscillate.
- If the system oscillates as in Fig. B.4 Mode A, or does not oscillate, refer to step 3).

3. Reduce the **Proportional Band** by 20% increments and observe the response. Continue until the process cycles continuously without reaching a stable condition (i.e. a sustained oscillation with constant amplitude as shown in Mode C). This is the critical point.
4. Note the cycle time 't' (Fig. B.4 Mode C) and the **Proportional Band** (critical value) setting.
5. Set **Proportional Band** to:
 - 1.6 times the critical value (for P+D or P+I+D control)
 - 2.2 times the critical value (for P+I control)
 - 2.0 times the critical value (for P only control)

6. Set **Integral Time** to:

$$\frac{t}{2} \text{ (for P+I+D control)}$$

$$\frac{t}{1.2} \text{ (for P+D control)}$$

7. Set **Derivative Time** to:

$$\frac{t}{8} \text{ (for P+I+D control)}$$

$$\frac{t}{12} \text{ (for P+D control)}$$

The analyzer is now ready for fine tuning by small adjustments to the P, I and D terms, after the introduction of a small disturbance of the set point.

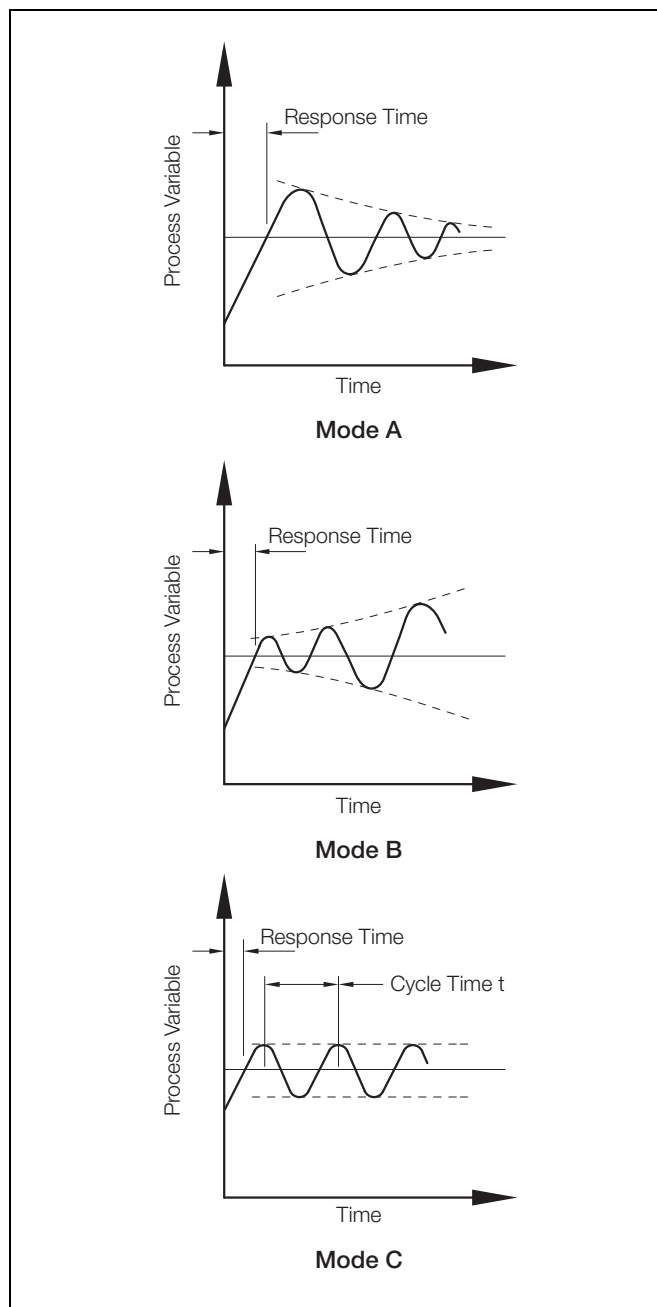

Fig. B.4 Control Conditions

Products and customer support

Automation Systems

For the following industries:

- Chemical & Pharmaceutical
- Food & Beverage
- Manufacturing
- Metals and Minerals
- Oil, Gas & Petrochemical
- Pulp and Paper

Drives and Motors

- AC and DC Drives, AC and DC Machines, AC Motors to 1kV
- Drive Systems
- Force Measurement
- Servo Drives

Controllers & Recorders

- Single and Multi-loop Controllers
- Circular Chart and Strip Chart Recorders
- Paperless Recorders
- Process Indicators

Flexible Automation

- Industrial Robots and Robot Systems

Flow Measurement

- Electromagnetic Flowmeters
- Mass Flowmeters
- Turbine Flowmeters
- Wedge Flow Elements

Marine Systems & Turbochargers

- Electrical Systems
- Marine Equipment
- Offshore Retrofit and Refurbishment

Process Analytics

- Process Gas Analysis
- Systems Integration

Transmitters

- Pressure
- Temperature
- Level
- Interface Modules

Valves, Actuators and Positioners

- Control Valves
- Actuators
- Positioners

Water, Gas & Industrial Analytics Instrumentation

- pH, Conductivity and Dissolved Oxygen Transmitters and Sensors
- Ammonia, Nitrate, Phosphate, Silica, Sodium, Chloride, Fluoride, Dissolved Oxygen and Hydrazine Analyzers
- Zirconia Oxygen Analyzers, Katharometers, Hydrogen Purity and Purge-gas Monitors, Thermal Conductivity

Customer support

We provide a comprehensive after sales service via a Worldwide Service Organization. Contact one of the following offices for details on your nearest Service and Repair Centre.

UK

ABB Limited
Tel: +44 (0)1453 826661
Fax: +44 (0)1453 829671

USA

ABB Inc.
Tel: +1 215 674 6000
Fax: +1 215 674 7183

Client Warranty

Prior to installation, the equipment referred to in this manual must be stored in a clean, dry environment, in accordance with the Company's published specification. Periodic checks must be made on the equipment's condition. In the event of a failure under warranty, the following documentation must be provided as substantiation:

- A listing evidencing process operation and alarm logs at time of failure.
- Copies of all storage, installation, operating and maintenance records relating to the alleged faulty unit.

Contact us

ABB Limited

Process Automation

Oldends Lane
Stonehouse
Gloucestershire GL10 3TA
UK

Tel: +44 1453 826 661

Fax: +44 1453 829 671

ABB Inc.

Process Automation

125 E. County Line Road
Warminster
PA 18974
USA

Tel: +1 215 674 6000

Fax: +1 215 674 7183

www.abb.com

Note

We reserve the right to make technical changes or modify the contents of this document without prior notice. With regard to purchase orders, the agreed particulars shall prevail. ABB does not accept any responsibility whatsoever for potential errors or possible lack of information in this document.

We reserve all rights in this document and in the subject matter and illustrations contained therein. Any reproduction, disclosure to third parties or utilization of its contents in whole or in parts – is forbidden without prior written consent of ABB.

Copyright© 2011 ABB

All rights reserved