

ZGP2 Series High Temperature Zirconia Oxygen Probe

Superior technology and quality from the world leader in oxygen measurement



Dependable

- measurement of O₂ in a wide variety of processes
- virtually instantaneous response
- resistance to sulphurous reducing atmospheres

Versatile

- 600 to 1250 mm (2 to 4 ft) lengths
- choice of protective sheath materials
- integral thermocouple for automatic temperature compensation

Low cost-of-ownership

- in situ measurement
- no sampling system required
- test gas port for in situ probe verification

Introduction

The ZGP2 Zirconia Oxygen Probe is designed to measure oxygen in oxidizing, and some reducing, furnace atmospheres. When used in conjunction with an appropriate electronics unit the probe output voltage may be converted to a signal related either to oxygen concentration (%O₂, ppm O₂) or oxidizing potential (kilocalories or millivolts) terms.

Concentration terms are usually applicable to measurements in oxidizing atmospheres and potential terms are used for reducing atmospheres.

The probe provides a true measurement of the atmospheric conditions in situ and permits continuous and accurate measurement over a wide temperature range, without the frequent maintenance associated with external sampling systems. It also eliminates 'equilibrium shift' that is common to systems in which gas samples are cooled before measurement, and has a fast response to changes in atmosphere enabling rapid corrective action to be taken when necessary. o-use, low-maintenance system for dissolved oxygen measurement.

Applications

- Annealing furnace atmosphere monitoring
- Sintering of metals
- Reheat furnaces
- Ferrite sintering
- Whiteheart malleablizing
- Combustion measurement and control in soaking pits
- Process heaters
- Fluid bed boilers
- High temperature incinerators
- Other combustion processes where the flue gas temperature is in excess of 600 °C (1112 °F)

Overall Dimensions

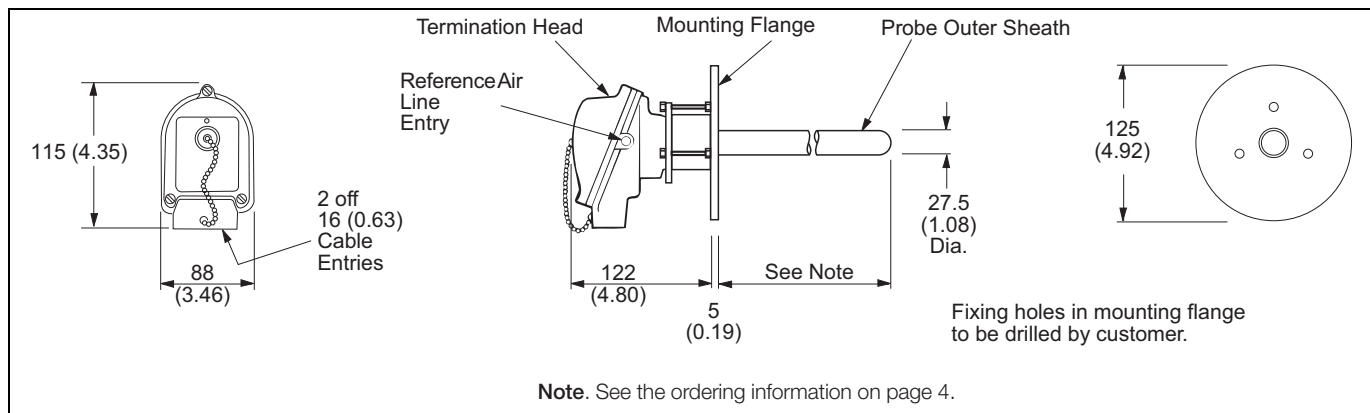

Principle of Operation

The probe comprises a ceramic detector cell housed in a protective sheath. A thermocouple is fitted within the probe to enable the process temperature to be monitored and provide automatic temperature compensation. A connector head (protected to IP56) enables connection of the cell output, thermocouple and reference air connections.

The sheath material can be:

Aluminous porcelain

for oxidizing atmospheres at temperatures up to 1250 °C (2284 °F) where limited amounts of corrosive chemicals are present

Recrystallized alumina

for reducing/oxidizing atmospheres at temperatures up to 1400 °C (2552 °F) and where corrosive chemicals are present

Incoloy 800

for reducing/oxidizing atmospheres at temperatures up to 850 °C (1562 °F) when mounted horizontally and up to 1000 °C (1832 °F) when mounted vertically.

A calibration gas inlet port is provided to enable the probe to be checked using test gas mixtures without removing it from the process.

Reference air (500 to 1000 ml/min [1 to 2 ft³/hr]) is required for accurate operation and can be supplied from an ABB mains-powered pump unit or a flow-regulator unit.

ZFG2 Series
High Temperature Zirconia Oxygen Probe

Specification

Temperature range

600 to 1250 °C (1112 to 2282 °F) continuous
1400 °C (2552 °F) max.

Measuring range

Refer to 'Operating Limits' diagram (below). The lower limit of operation, determined by the onset of electronic conduction in the solid electrolyte, is dependent on temperature.

The following limits are given as a guide for 1 % electronic conduction but, in practice, it may be possible to measure at even lower oxygen potential levels without introducing significant errors.

Temperature Concentration		Minimum O ₂ Output	Minimum O ₂ Potential		
°C	°F	Kcals	bar	psi	mV
600	1112	-145	10 ⁻³⁶	145 ⁻³⁶	1532
900	1652	-132	10 ⁻²⁵	145 ⁻²⁵	1391
1200	2192	-117	10 ⁻¹⁷	145 ⁻¹⁷	1228

Response rate

<42 s to 63 % of final value, <47 s to 90 % of final value

Reference air

Clean oil-free air
Flow rate 500 to 1000 ml/minute (1 to 2 ft³/hr)

Construction

- Solid electrolyte stabilized zirconia oxide
- Protective sheath aluminous porcelain
- Incoloy 800
- recrystallized alumina

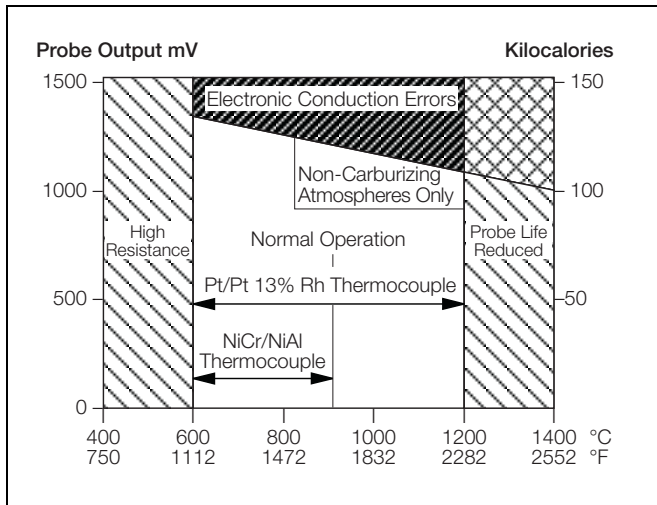

Operating Limits

Mounting

Vertical or horizontal 42 mm (1.65 in) minimum hole diameter

Connecting cable

- 2-core copper, overall screened for probe output
- 2-core compensating cable to suit thermocouple fitted

Thermocouple

Pt/Pt 13 % Rh – EN 60584.1 Pt2 type R	600 to 1250 °C (1112 to 2282 °F)
NiCr/NiAl – Pt4 EN 60584.1 Pt4 type K	600 to 900 °C (1112 to 1652 °F)

Weight

- 2.5 kg (5.5 lb) nett (600 mm [22 in] probe)
- 2.8 kg (6.2 lb) nett (1000 mm [37.5 in] probe)

Ordering Information

ZGP2 Series High Temperature Zirconia Oxygen Probe	ZGP2/	X	X	X	X	X
Nominal Insertion Length mm (in)						
600 (23.6)		1				
1000 (39.4)		2				
700 (27.6)		3				
800 (31.5)		4				
900 (35.5)		5				
1250 (49.2)		6				
Special		9				
Thermocouple						
Pt/Pt 13% Rh EN 60584.1 Pt2 Type R			1			
NiCr/NiAl EN 60584 Pt4 Type K			2			
Pt/Pt 10% RH EN 60584.1 Pt 1 Type S			3			
Special			9			
Sheath						
Aluminous porcelain (Standard)				1		
Incoloy 800				2		
Recrystallized alumina				3		
Special				9		
Mounting						
Standard						1
1 in NPT						2
Special						9
Termination Head						
Twin-gland type C95						1

Contact us

ABB Limited

Process Automation

Oldends Lane
Stonehouse
Gloucestershire GL10 3TA
UK

Tel: +44 1453 826 661

Fax: +44 1453 829 671

ABB Inc.

Process Automation

125 E. County Line Road
Warminster
PA 18974
USA

Tel: +1 215 674 6000

Fax: +1 215 674 7183

www.abb.com

Note

We reserve the right to make technical changes or modify the contents of this document without prior notice. With regard to purchase orders, the agreed particulars shall prevail. ABB does not accept any responsibility whatsoever for potential errors or possible lack of information in this document.

We reserve all rights in this document and in the subject matter and illustrations contained therein. Any reproduction, disclosure to third parties or utilization of its contents in whole or in parts – is forbidden without prior written consent of ABB.

Copyright© 2010 ABB
All rights reserved

3KXA611802R1001