

9408 Series Dissolved Oxygen Systems

Dissolved oxygen systems
designed for reliable operation
with minimal operating costs



Reduced sensor fouling design

- minimizes operational costs

Low maintenance, long-life sensor

- easy to maintain

Complete systems and kit versions available

- satisfies a wide range of applications

On-line water wash option

- extends duration between maintenance reducing operational costs

Stainless steel mounting brackets

- eliminates corrosion problems

General

Reliable monitoring of dissolved oxygen levels in sewage treatment works is often hampered by fouling of the sensor with rags, or other large solids, present in the sample under test. These materials tend to become attached to the sensor and sensor holder giving rise to incorrect readings.

This problem is avoided by using the Model 9408 Floating Ball Dissolved Oxygen System, which comprises a flat-ended sensor mounted into a relatively large diameter spherical flotation collar. This form of construction presents to the sample a surface on which it is difficult for rags and other large solids to lodge. For more demanding applications, on-line cleaning is available using the water wash option.

The Floating Ball has been designed to operate in conjunction with the ABB Models 4640 and 4645 Dissolved Oxygen Transmitters and provides an easy-to-use, low-maintenance system for dissolved oxygen measurement.

9408-700 Floating Ball System

The system utilizes a sensor assembly which includes an 8012-170 sensor capsule. This assembly is mounted into a support tube which also houses a temperature sensor for automatic temperature compensation. The support tube, in turn, fits onto a 3 m (9.75 ft) long pivoted boom via which the system is attached to the guard rail around the aeration tank.

The support bracket is manufactured from stainless steel to ensure maximum life.

The spherical flotation collar is secured around the support tube to provide buoyancy, allowing the sensor to be maintained a few centimetres below the surface of the sample.

9408-750 and 9408-760 Floating Ball Systems

The floating ball system is supplied in kit form, without the support arm, to reduce carriage costs and minimize handling difficulties when onward transportation to site is involved. A tube of solvent cement is provided with the kit to complete the simple construction of the system.

Kits are available in both metric and imperial sizes to suit local requirements and can be supplied with the Swivel-bracket option.

9408-710, -720 and -730 Dip Systems

The 9408 Dip Systems are of rugged construction and are intended for use in aeration tanks and open channels. Incorporated within the system is a 3-wire Pt100 temperature probe together with an oxygen sensor body. The system is supplied fully assembled and requires only the 8012-170 oxygen capsule to be fitted to make the system operational.

The system has been designed with ease of maintenance being a major consideration. Periodic replacement of the disposable oxygen capsule being the only routine maintenance apart from calibration checks.

The systems are provided with wall-mounting brackets.

9408-600 Submersible System

To enable monitoring where there is a high rise and fall of the sample, e.g. 3 m (9.75 ft) and greater, or where access is difficult, a submersible version 9408-600 is available. It is supplied with 10 m (32.5 ft) of cable as standard.

Provision is made for a support chain to be attached to determine the level of immersion and to protect the signal cable from excessive strain.

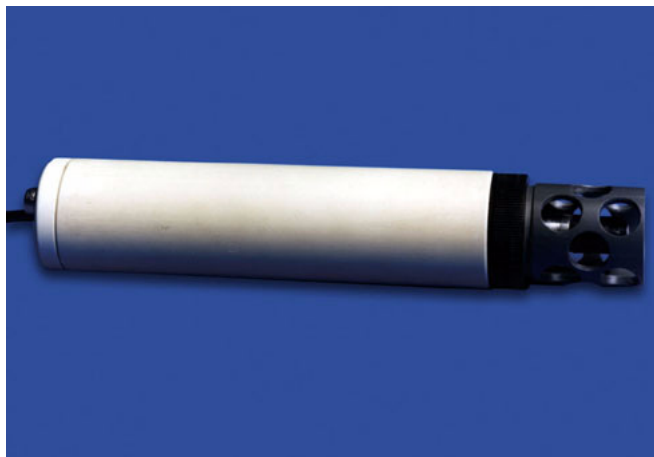

Submersible Probe

Swivel Bracket Option

To make routine maintenance even easier and more convenient, there is an option to order the floating ball system with a swivel bracket. This enables the system to be rotated horizontally for cleaning purposes without the need to remove it completely.



Swivel-bracket – Optional Extra

The Sensor Model 8012/170

To make routine maintenance even easier and more convenient, there is an option to order the floating ball system with a swivel bracket. This enables the system to be rotated horizontally for cleaning purposes without the need to remove it completely.



Model 8012/1170 Oxygen Sensors

Calibration

All that is essential to calibrate the system is a full-scale calibration, carried out in air or in air-saturated water. Zero calibration of the sensor is not essential but can be carried out in a 5 % solution of sodium sulphite.

Maintenance

Maintenance is limited to periodic cleaning and calibration, no refurbishment of the sensor being necessary. A replacement sensor capsule can be easily fitted when required. Sensor life varies depending upon the application but is typically 9 to 12 months.

Water Wash

On applications where maintenance demands are high, or where performance is critical, ABB offer on-line water wash feature. Field trials have demonstrated extended life and significantly reduced maintenance levels.

Specification

Floating Ball System

Sensor type

8012-170 sensor capsule

Response

Typically 20 s for 90 % of a step-change of oxygen concentration at 20 °C (68 °F)

Temperature compensation

Automatic correction by means of an integral Pt100 resistance thermometer

Operating temperature

0 to 40 °C (32 to 104 °C)

Operating pressure

Atmosphere

Minimum liquid velocity

30 cm/s (11.8 in/s)

Accuracy

±0.2 mg/l or ±2 % saturation within ±10 °C (50 °F) of the calibration temperature in the range 0 to 35 °C (32 to 95 °F)

Materials of construction

Support arm (for 9408-750 kit)

ABS plastic o.d. 50 mm Wall thickness 3.3 mm (0.13 in)

Pressure rating 10 bar

Support arm (for 9408-760 kit)

ABS plastic OD 48.3 mm (1.9 in). Wall thickness 4.5 mm (0.18 in)

Pressure rating 10 bar

Flotation collar - polypropylene

Mounting bracket - stainless steel

Mounting

Pipe-mounting (50 mm [1.97 in] OD)

Connection cable

10 m (32.5 ft) fitted as standard

Part no. 0233-828. Maximum distance 100 m (325 ft) via junction box (customer supply)

Optional Swivel-bracket accessory

Part no. 9408-135 for use with 9408-750 and 9408-752

Part no. 9408-136 for use with 9408-760 and 9408-762

Ordering Information

9408-700	Floating Ball system complete with support arm, mounting brackets and all other accessories or
9408-750	Floating Ball kit (metric) comprising a complete 9408-700 system without the 3 m support arm (which is available from local stockists) Included within the kit is a tube of suitable solvent cement which is used to secure the 3 m support arm or
9408-752	As 9408-750 above but without water-wash or
9408-760	Floating Ball kit (imperial) comprising a complete 9408-700 system without the 10ft support arm (which is available from local stockists) Included within the kit is a tube of suitable solvent cement which is used to secure the 10ft support arm
9408-762	As 9408-760 above but without water-wash

Connection Cable

10 m (32.5 ft) fitted as standard

Part no. 0233-828. Maximum distance 100 m (325 ft) via junction box (customer supply)

Instruments

All 9408 systems are compatible with the 4640 and 4645 dissolved oxygen transmitters (see Data sheet SS/4640)

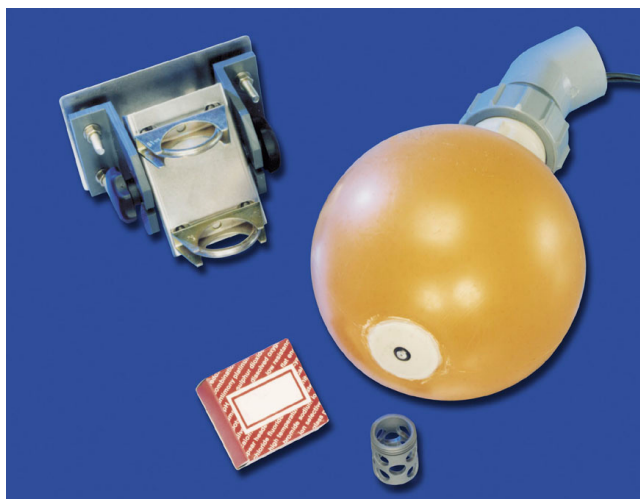

9408 Floating Ball Kit – Swivel-bracket Not Included

Overall Dimensions – Floating Ball System

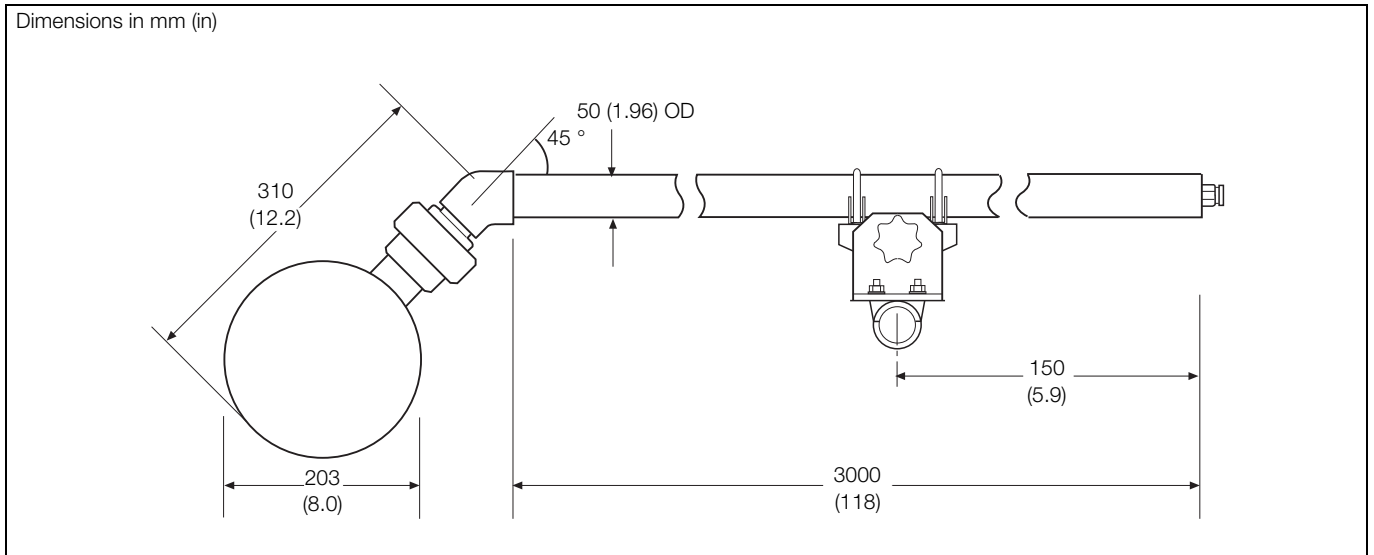

Specification

Dip and Submersible Systems

Sensor type

8012-170 sensor capsule

Response

Typically 20 s for 90 % of a step-change of oxygen concentration at 20 °C (68 °F)

Temperature compensation

Automatic correction by means of an integral Pt100 resistance thermometer

Operating temperature

0 to 40 °C (32 to 104 °F)

Operating pressure

Atmospheric

Minimum liquid velocity

30 cm/s (11.8 in/s)

Accuracy

±0.2 mg/l or ±2 % saturation within ±10 °C (50 °F) of the calibration temperature in the range 0 to 35 °C (32 to 95 °F)

Materials of construction

Polypropylene

Mounting

Wall-mounting bracket

Connection cable

10 m (32.5 ft) fitted as standard

Maximum distance 100 m (325 ft) via junction box (customer supply)

Ordering Information

Dip Systems

9408-710	1 m (3.25 ft) system complete
9408-720	2 m (6.50 ft) system complete
9408-730	3 m (9.75 ft) system complete
Cable	10 m (32.5 ft) fitted as standard
Part no. 0233-828. Maximum distance 100 m (325 ft) via junction box (customer supply)	

Dip Systems with Water-wash

9408-712	1 m (3.25 ft) system complete with Water-wash
9408-722	2 m (6.50 ft) system complete with Water-wash
9408-732	3 m (9.75 ft) system complete with Water-wash
Cable	10 m (32.5 ft) fitted as standard
Part no. 0233-828. Maximum distance 100 m (325 ft) via junction box (customer supply)	

Dip System Kits

9408-770	Dip kit metric version non-Water-wash
9408-771	Dip kit imperial version non-Water-wash
9408-772	Dip kit metric version complete with Water-wash
9408-773	Dip kit imperial version complete with Water-wash

Submersible

9408-600	Submersible system complete with 10 m (32.5 ft) of connection cable
Part no. 0233-828. Maximum distance 100 m (325 ft) via junction box (customer supply)	

Submersible with Water-wash

9408-602	Submersible system complete with 10 m (32.5 ft) of connection cable
Part no. 0233-828. Maximum distance 100 m (325 ft) via junction box (customer supply)	

Overall Dimensions – Dip System

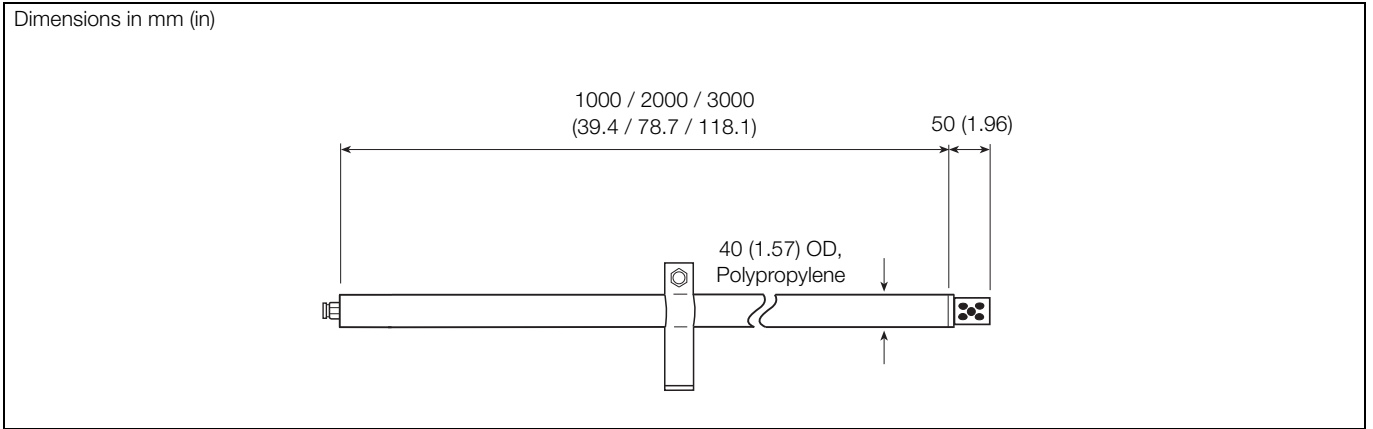

Contact us

ABB Limited

Process Automation

Oldends Lane
Stonehouse
Gloucestershire GL10 3TA
UK

Tel: +44 1453 826 661

Fax: +44 1453 829 671

ABB Inc.

Process Automation

125 E. County Line Road
Warminster
PA 18974
USA

Tel: +1 215 674 6000

Fax: +1 215 674 7183

www.abb.com

Note

We reserve the right to make technical changes or modify the contents of this document without prior notice. With regard to purchase orders, the agreed particulars shall prevail. ABB does not accept any responsibility whatsoever for potential errors or possible lack of information in this document.

We reserve all rights in this document and in the subject matter and illustrations contained therein. Any reproduction, disclosure to third parties or utilization of its contents in whole or in parts – is forbidden without prior written consent of ABB.

Copyright© 2011 ABB

All rights reserved

3KXA494001R1001