



ABB

The Company

We are an established world force in the design and manufacture of instrumentation for industrial process control, flow measurement, gas and liquid analysis and environmental applications.

As a part of ABB, a world leader in process automation technology, we offer customers application expertise, service and support worldwide.

We are committed to teamwork, high quality manufacturing, advanced technology and unrivalled service and support.

The quality, accuracy and performance of the Company's products result from over 100 years experience, combined with a continuous program of innovative design and development to incorporate the latest technology.

The UKAS Calibration Laboratory No. 0255 is just one of the ten flow calibration plants operated by the Company and is indicative of our dedication to quality and accuracy.

EN ISO 9001:2000



Cert. No. Q 05907

EN 29001 (ISO 9001)



Lenno, Italy – Cert. No. 9/90A

Stonehouse, U.K.



Electrical Safety

This equipment complies with the requirements of CEI/IEC 61010-1:2001-2 'Safety Requirements for Electrical Equipment for Measurement, Control and Laboratory Use'. If the equipment is used in a manner NOT specified by the Company, the protection provided by the equipment may be impaired.

Symbols

One or more of the following symbols may appear on the equipment labelling:

	Warning – Refer to the manual for instructions		Direct current supply only
	Caution – Risk of electric shock		Alternating current supply only
	Protective earth (ground) terminal		Both direct and alternating current supply
	Earth (ground) terminal		The equipment is protected through double insulation

Information in this manual is intended only to assist our customers in the efficient operation of our equipment. Use of this manual for any other purpose is specifically prohibited and its contents are not to be reproduced in full or part without prior approval of the Technical Publications Department.

Health and Safety

To ensure that our products are safe and without risk to health, the following points must be noted:

1. The relevant sections of these instructions must be read carefully before proceeding.
2. Warning labels on containers and packages must be observed.
3. Installation, operation, maintenance and servicing must only be carried out by suitably trained personnel and in accordance with the information given.
4. Normal safety precautions must be taken to avoid the possibility of an accident occurring when operating in conditions of high pressure and/or temperature.
5. Chemicals must be stored away from heat, protected from temperature extremes and powders kept dry. Normal safe handling procedures must be used.
6. When disposing of chemicals ensure that no two chemicals are mixed.

Safety advice concerning the use of the equipment described in this manual or any relevant hazard data sheets (where applicable) may be obtained from the Company address on the back cover, together with servicing and spares information.

Contents

1 INTRODUCTION	2	6 ROUTINE MAINTENANCE	16
1.1 Schematic Diagrams	2	6.1 'O' Ring Seals	16
2 PREPARATION	3	6.2 Cleaning	16
2.1 Checking the Code Number	3	6.3 Checking the Electrolyte Level	16
2.2 Identifying the Electrode Type	4	6.4 Replacing Electrodes	16
2.3 Checking the Cable Specification	6	6.4.1 Measuring Electrodes	16
2.4 Cleaning Options	6	6.4.2 Reference Electrodes	16
3 MECHANICAL INSTALLATION	6	6.5 Recommended Maintenance of the Company's pH Systems	17
3.1 Siting	6	6.6 Fault Finding	17
3.1.1 Operating Limits	6	6.7 Loss of Sample	17
3.1.2 Operating Pressure & Temperature	7	7 SPARES	18
3.2 Installing the System	8	7.1 Models 7651, 7652	18
3.2.1 Models 7651, 7652, 7660 and 7661	8	7.2 Models 7654, 7655, 7656	18
3.2.2 Model 7652	8	7.3 Model 7660 (stainless steel)	18
3.2.3 Models 7654, 7655, 7656, 7664 and 7665 ...	8	7.4 Reservoir Spares	18
3.3 Fitting Electrodes	9	Notes	19
3.3.1 Removing the Sensor Holder	9		
3.3.2 Fitting the Reference Electrode	10		
3.3.3 Fitting the Measuring Electrode, and the Tem- perature Compensator 1750-000 (if required) .	11		
3.3.4 Completion Tasks	11		
3.4 Fitting the Reservoir - Models 7651, 7652, 7660 and 7661	11		
4 ELECTRICAL INSTALLATION	14		
4.1 Connection to AX, 4500 and 4600 Series Transmitters 14			
4.2 Connection to Hazardous Area Systems	14		
4.3 Cable Termination	15		
5 CALIBRATING THE SYSTEM	15		
5.1 General Calibration of Electrodes	15		
5.2 Calibration of Electrodes used in High Purity Water Ap- plications	15		
5.2.1 Monthly Calibration	15		
5.2.2 3-Monthly Calibration	15		

1 INTRODUCTION

This manual describes how to install and operate 7600 Series industrial electrode systems. These systems are suitable for use with a variety of measuring electrodes and pH meters operating over a wide range of pressures and temperatures.

This manual describes:

- **Model 7651** - polypropylene with optional pipe and flange fittings.
- **Model 7660** - stainless steel, in-line flow system.
- **Model 7661** - PVDF, 1 inch flow system.
- **Model 7652** - polypropylene, 2 inch in-line system with 2 inch BS10 Table E flange fittings.
- **Model 7654** - polypropylene, 1 metre (nominal) dip system.
- **Model 7664** - PVDF, 1 metre (nominal) dip system.
- **Model 7655** - polypropylene, 2 metre (nominal) dip system.
- **Model 7665** - PVDF, 2 metre (nominal) dip system.
- **Model 7656** - polypropylene, 3 metre (nominal) dip system.

Dip systems are for use in tanks, channels, etc.

All the above models are compatible with the AX, 4500 and 4600 Series pH transmitters. They may also be used with other instruments such as 9140, 9170 and 9180 Series, but care must be taken when connecting the temperature compensator - see section 4.1, page 14 for further details.

An alternative range of systems is available for use in hazardous areas using approved intrinsically safe transmitters - see section 4.2, page 14.

1.1 Schematic Diagrams

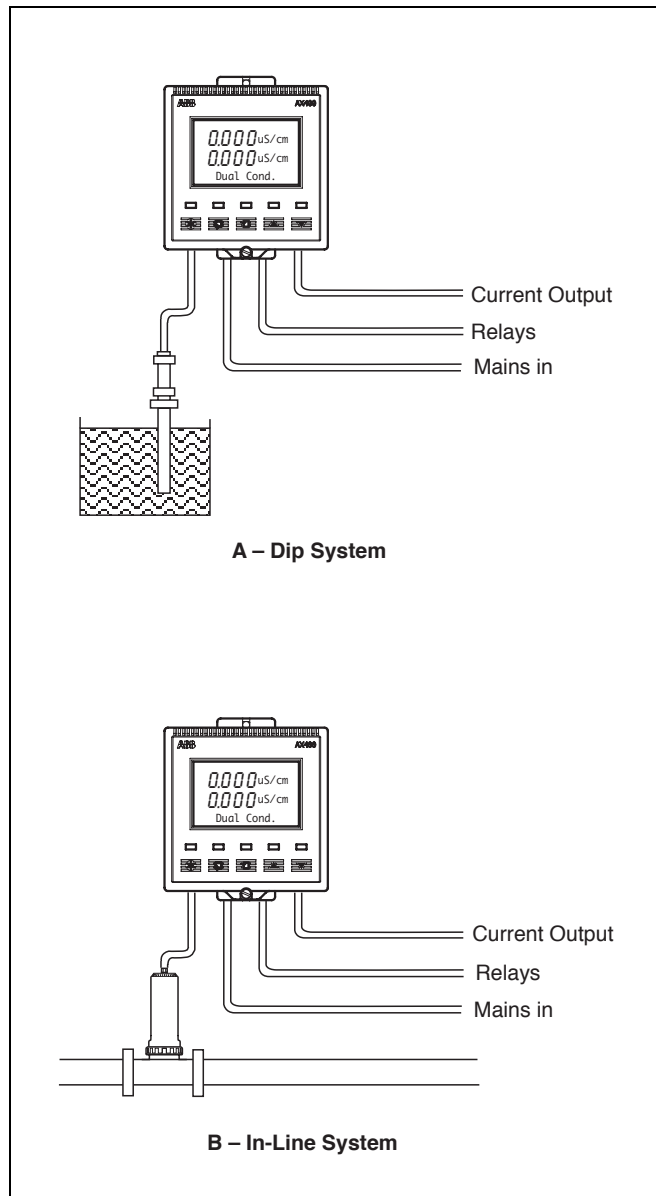

Fig. 1.1 Schematic Diagrams

2 PREPARATION

2.1 Checking the Code Number

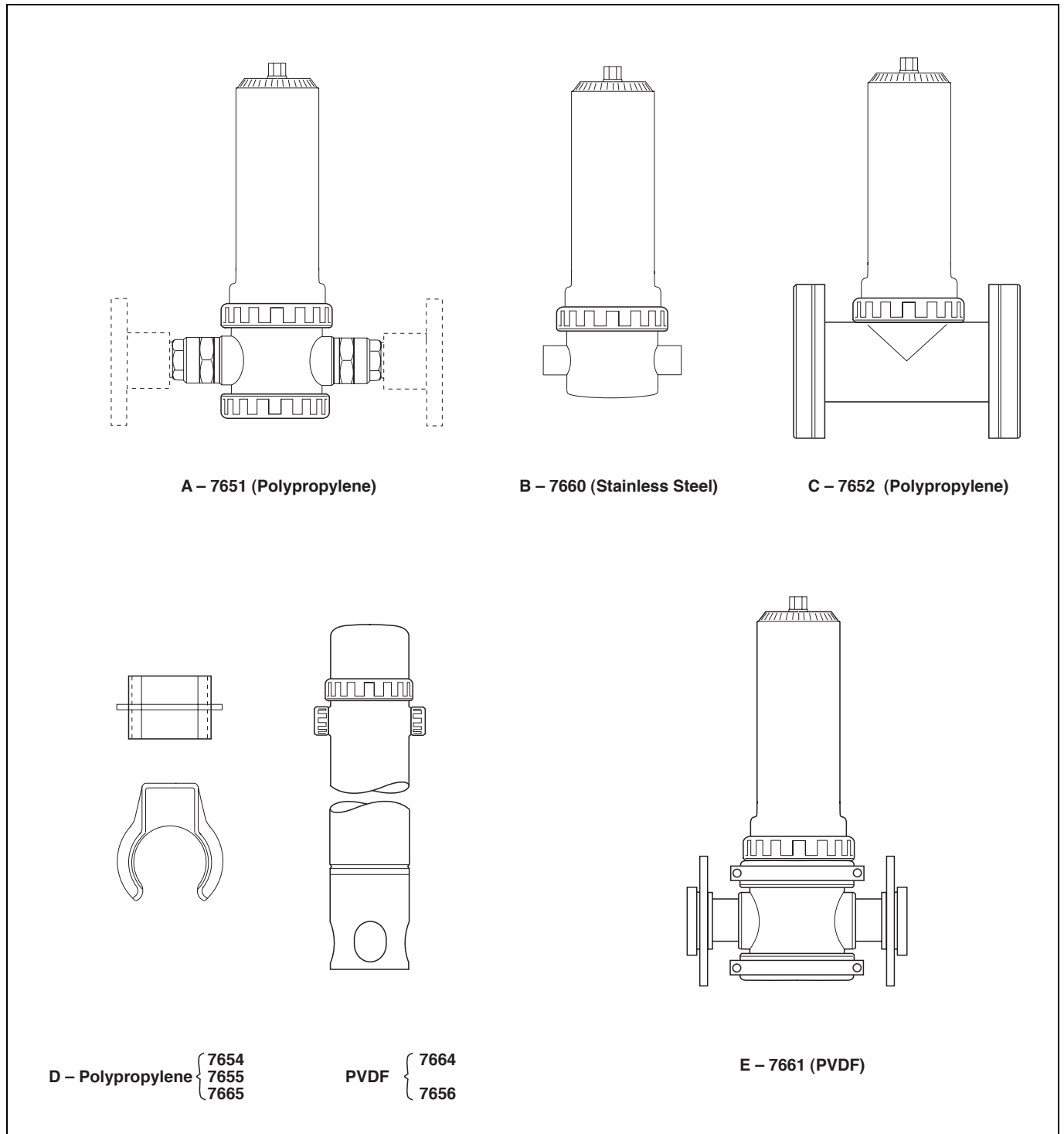

Fig. 2.1 System Types

2.2 Identifying the Electrode Type

A pH system is only as accurate as the electrodes used to make the measurement. To satisfy a wide range of applications, and to meet the demands of modern processes, the Company has produced a range of electrodes to satisfy most requirements.

Reference Electrode (1730-000) fitted to all systems - used in a sealed electrolyte or reservoir fed system, e.g. for applications where the conductivity of the water is less than $30 \mu\text{S cm}^{-1}$.

General Purpose Electrode (1720-000) - suitable for most industrial applications. Operates from 0 to 14 pH, 0 to 100°C (32 to 212°F) and must be used when the mechanical wiper is fitted.

Low Resistance Electrode (1722-000) - low resistance membrane electrode for low temperature. For use in the water industry where the sample temperature drops below 10°C (50°F). Operates from 0 to 10 pH, 0 to 70°C (32 to 158°F).

Note. For conductivities less than $30 \mu\text{S cm}^{-1}$ a stainless steel system is recommended.

Cone Shaped Electrode (1721-000) - heavy duty electrode designed specifically for ultrasonic cleaning. Operates from 0 to 14 pH, 0 to 100°C (32 to 212°F).

Low Temperature Cone Electrode (1723-000) - designed for use with ultrasonic cleaner and especially where the sample is at low conductivity/low temperature. Operates from 0 to 10 pH, 0 to 70°C (32 to 158°F).

Platinum Electrode for Redox (ORP), (1740-000) - platinum electrode enables Redox (ORP) measurements to be made using any of the electrode systems.

Antimony pH Electrode (1741-000) - designed to work in applications when hydrofluoric acid is present.

Temperature Compensator (1750-000) - three-wire PT100 temperature compensator required to ensure high accuracy. It is compatible with older generations of Company instruments as well as the current models.

Note. All of these electrodes are compatible with the AX, 4500 and 4600 Series, 9140, 9170 and 9180 Series transmitters.

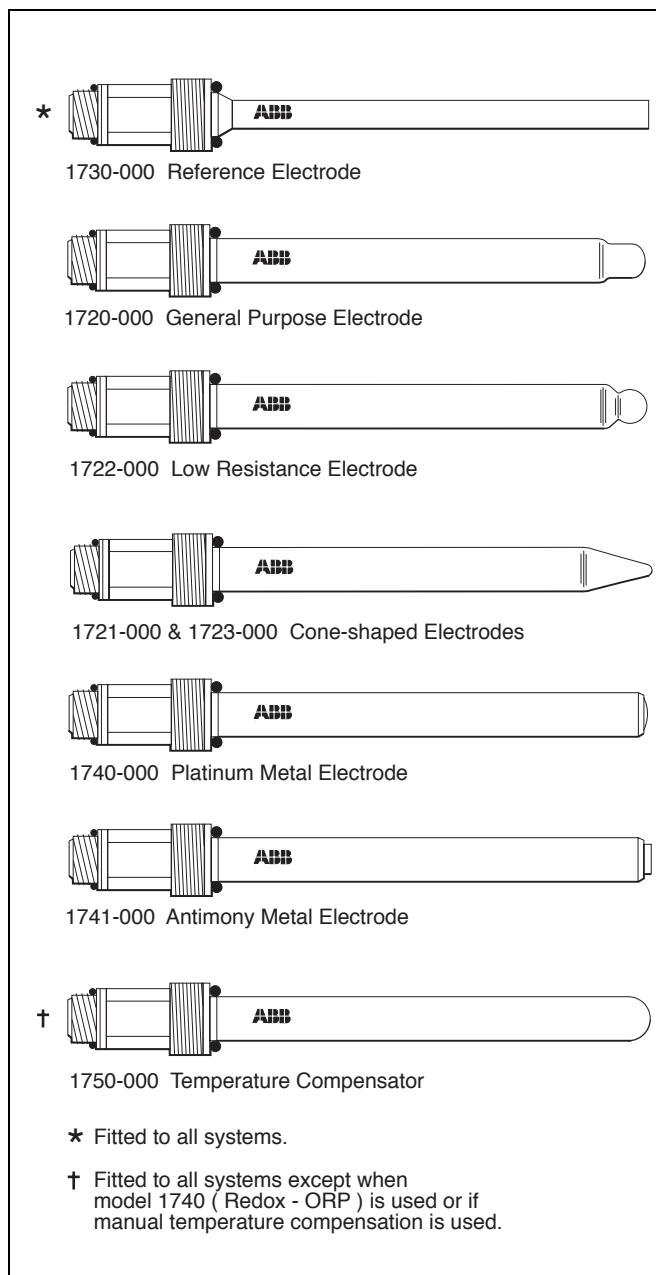

Fig. 2.2 Electrode Models

7600 Series pH/Redox Electrode System		76	XX	/	0	X	X		
System Type and Material Note. For 1 metre and 2 metre dip systems using mechanical or ultrasonic cleaning, please refer to separate specification sheet. Note. For ultrasonic and mechanical cleaning in Dip systems, refer to the appropriate manual for electrode details.	Polypropylene Systems Flow system with 1/2 in and 1 in process connections Flow system with 2 in BS10 Table E flange connections Dip system - 1 m (39 in) Dip system - 2 m (78 in) Dip system - 3 m (118 in)	51							
	52								
	54								
	55								
	56								
	Stainless Steel System Flow system with 3/8 in NPT process connections	60							
	PVDF Systems Flow system with 1/2 in and 1 in process connections Dip system - 1 m (39 in) Dip system - 2 m (78 in)	61							
	64								
	65								
	Connection Cable Length and Type Note. For Intrinsically Safe systems a maximum cable length of 5 metres is permitted.	With Automatic Temperature Compensation No cable 3 m (10 ft) length 5 m (16 ft) length 10 m (33 ft) length 20 m (66 ft) length Special length						0 1 2 3 4 S	
For Redox (ORP) No cable 3 m (10 ft) length 5 m (16 ft) length 10 m (33 ft) length 20 m (66 ft) length Special length							0 5 6 7 8 M		
Sensor Types Note. For PVDF systems, only options 1, 5 and 7 are available.		No sensor						0	
		1720-000 all purpose glass electrode						1	
		1730-000 standard reference electrode							
		1750-000 PT100 temperature compensator Recommended for industrial process/waste water							
		1722-000 low resistance glass electrode *1730-000 standard reference electrode 1750-000 PT100 temperature compensator Recommended for potable waters							2
		1721-000 cone shaped glass electrode 1730-000 standard reference electrode 1750-000 PT100 temperature compensator To be used with ultrasonic cleaner for industrial applications							3
		1723-000 low resistance cone shaped glass electrode *1730-000 standard reference electrode 1750-000 PT100 temperature compensator Recommended for potable waters where ultrasonic cleaning is necessary							4
1740-000 Platinum electrode (Redox/ORP) 1730-000 standard reference electrode For Redox/ORP applications								5	
1741-000 Antimony electrode (pH) 1730-000 standard reference electrode Recommended for pH applications where Hydrofluoric Acid is present in the sample							6		
1724-000 high temperature glass electrode 1730-000 standard reference electrode 1750-000 PT100 temperature compensator For high temperature applications							7		

Table 2.1 Electrode Data

2.3 Checking the Cable Specification

Check that cable length and termination is correct for the types of electrode system being used - see Table 2.1 and Fig. 2.3.

2.4 Cleaning Options

The following methods of cleaning are available:

- Flow powered
- Ultrasonic
- Mechanical wiping

For assembly instructions refer to the appropriate instruction manual (part no. IM/7600-CLN).

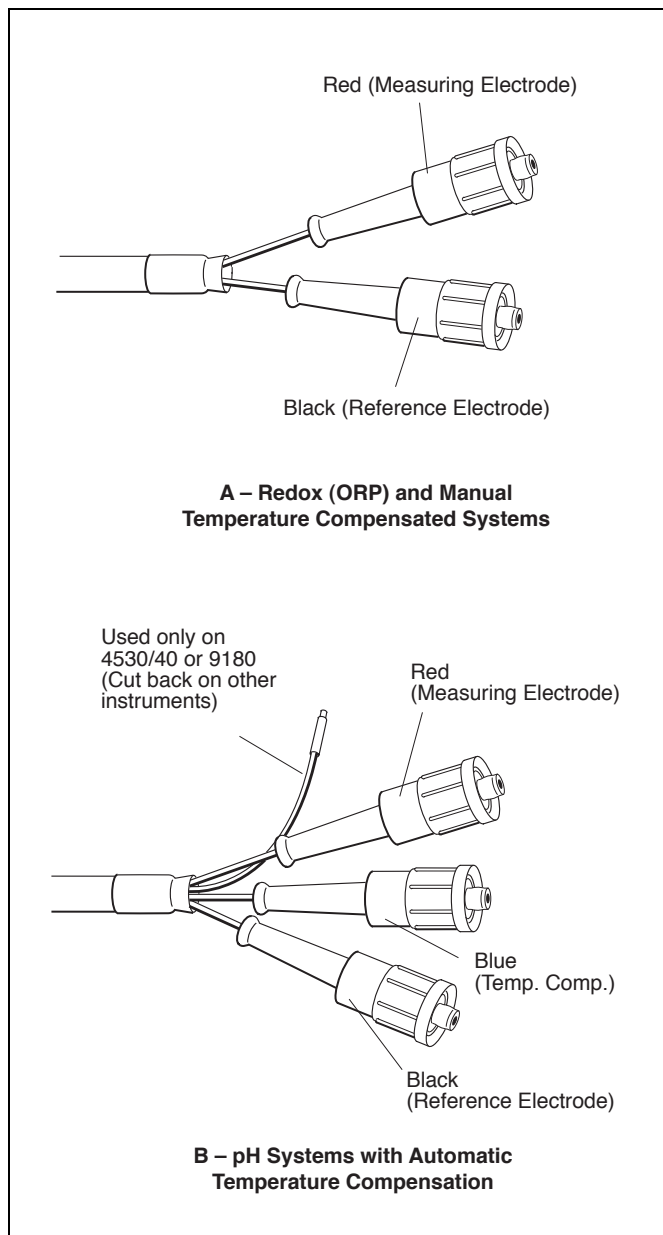

Fig. 2.3 Cable Termination - Electrode Connections

3 MECHANICAL INSTALLATION

Caution.

Ensure that the system cable is fed through the electrode system cover (or dip tube) before the cable is installed. To avoid the risk of damp or corrosive air damaging the cable plugs, connect to the electrodes as soon as possible.

It is essential that fitted electrodes remain wet. If there is loss of sample the fitted electrodes remain serviceable while there is sample in the flowcell. This may last for about a week depending on prevailing climatic conditions. If it appears that electrodes are drying out, periodically check and top up the flowcell reservoir with clean water or buffer solution.

3.1 Siting

3.1.1 Operating Limits

Model 7651 (Flow Type) see Fig. 3.1A for details

pH range:	0 to 14
Operating temperature range:	0 to 100°C (32 to 212°F)
Maximum operating temperature:	100°C at 2.1bar (212°F at 30psi)
Maximum operating pressure at 25°C (77°F):	10.6bar (150psi)

Model 7652 (In-line Type) see Fig. 3.1B for details

pH range:	0 to 14
Operating temperature range:	0 to 70°C (32 to 158°F)
Maximum operating temperature:	70°C (158°F), with no pressure
Maximum operating pressure at 25°C (77°F):	2.6bar (37psi)

Model 7654/5/6 (Dip Type)

pH range:	0 to 14
Operating temperature range:	0 to 80°C (32 to 176°F)
Maximum operating temperature:	80°C at 2.8bar (176°F at 40psi)
Maximum operating pressure at 25°C (77°F):	2.8bar (40psi)

Model 7660 (Flow Type)

pH range: 0 to 14
 Operating temperature range: 100°C at 2.1bar (212°F at 30psi)
 Maximum operating temperature: 0.3bar (5psi)
 Maximum operating pressure at 25°C (77°F): 10.6bar (150psi)

Model 7661 (Flow Type) see Fig. 3.1C for details

pH range: 0 to 14 (0 to 11 at elevated temperatures)
 Operating temperature range: 0 to 110°C (32 to 230°F)
 Maximum operating temperature: 110°C at 1.7bar (230°F at 25psi)
 Maximum operating pressure at 25°C (77°F): 6.6bar (95psi)

Model 7664/5 (Dip Type)

pH range: 0 to 14
 Operating temperature range: 0 to 110°C (32 to 230°F)
 Maximum operating temperature: 110°C (230°F)

3.1.2 Operating Pressure & Temperature

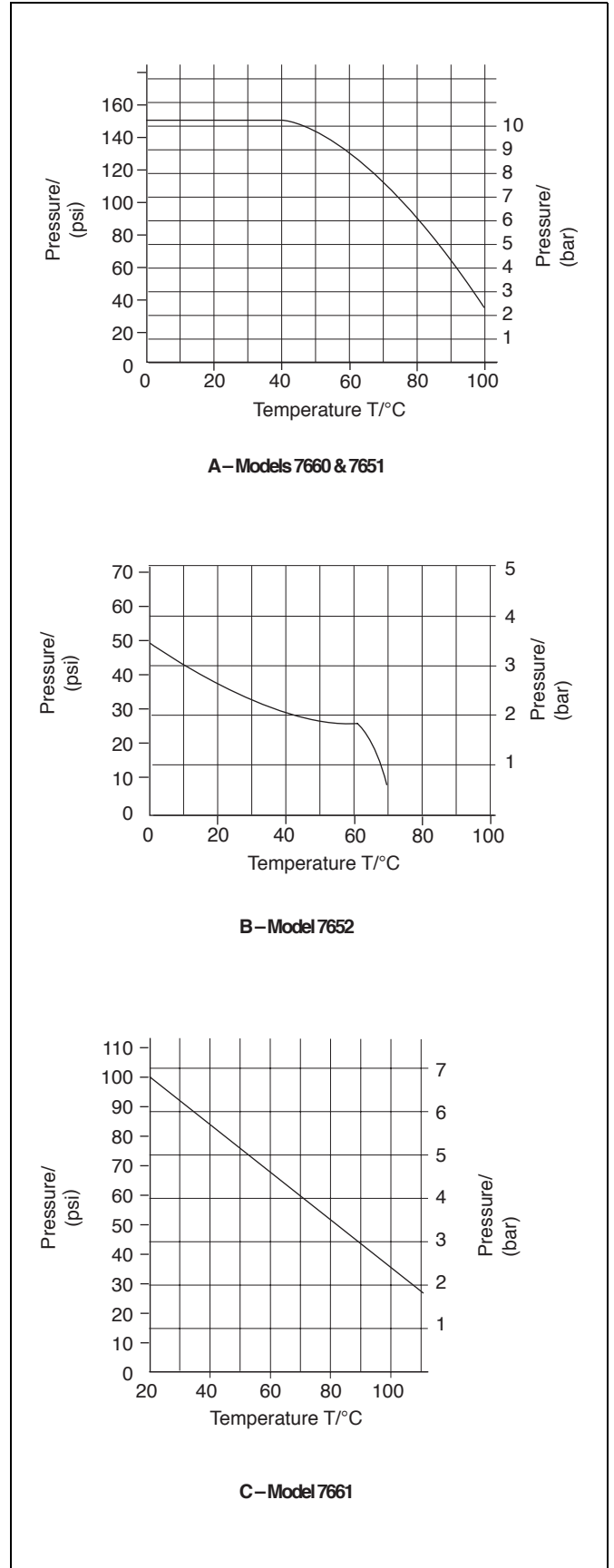

Fig. 3.1 Operating Temperatures and Pressures

3.2 Installing the System

3.2.1 Models 7651, 7652, 7660 and 7661

These may be mounted in any convenient position for the pipe connections, using flexible or rigid piping. Allow sufficient space above the system to enable the top cap to be unscrewed and removed and for the entire electrode holder unit to be removed from the flowcell for calibration.

The flowcell on Models 7651, 7660 and 7661 is provided with two threaded fixing holes to support the electrode system from a convenient vertical surface - see Fig. 3.2 and Fig. 3.5. Also, a plastic-coated bracket (7600 960) is supplied to enable the system to be mounted on a wall (when it is not possible to fit bolts from the back of the system). This bracket has an overall dimension of 164 x 60mm (6 1/2 x 2 3/8 in) diameter on fixing centres 140 x 40mm (5 1/2 x 1 9/16 in), symmetrically spaced, or with two bolts 12mm (1/2 in) diameter on fixing centres 140mm (5 1/2 in) apart.

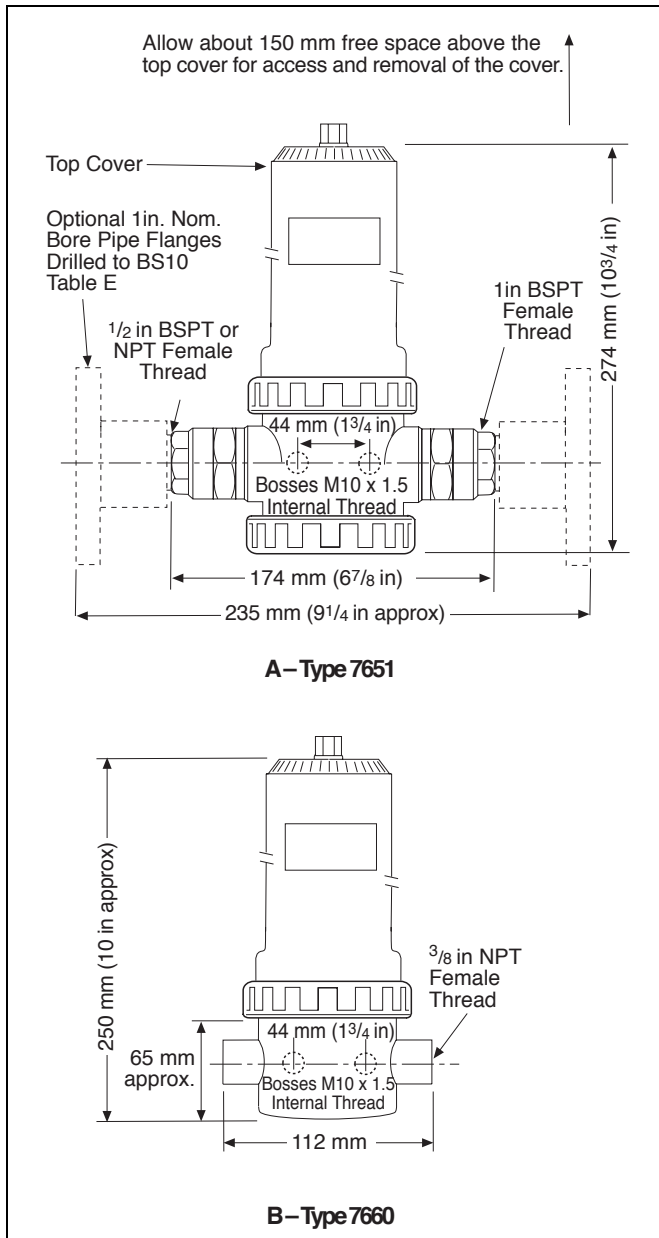

Fig. 3.2 Mounting, Types 7651 and 7660

3.2.2 Model 7652

This is installed and held in position by the 2 in BS10 Table E fixing flange only.

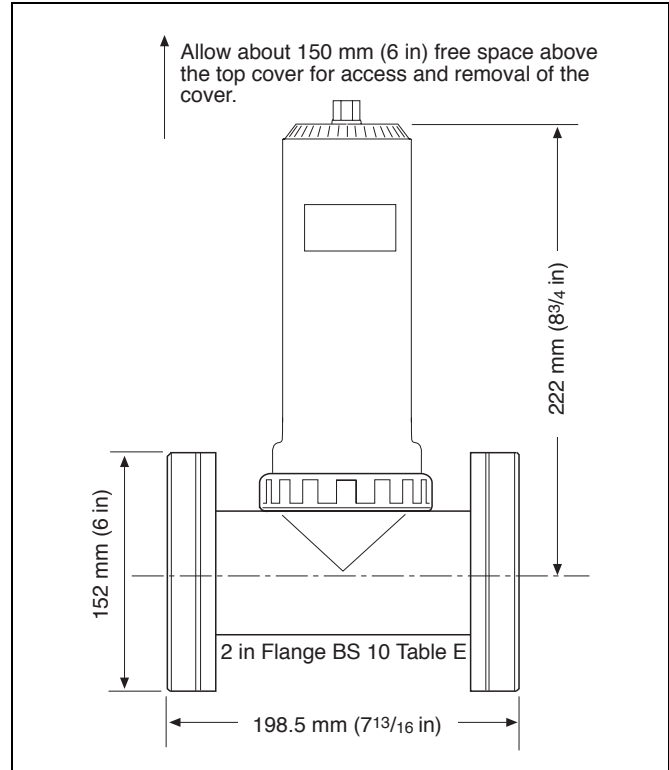

Fig. 3.3 Mounting, Type 7652

3.2.3 Models 7654, 7655, 7656, 7664 and 7665

These are dip systems installed in any convenient position over the open tank or channel.

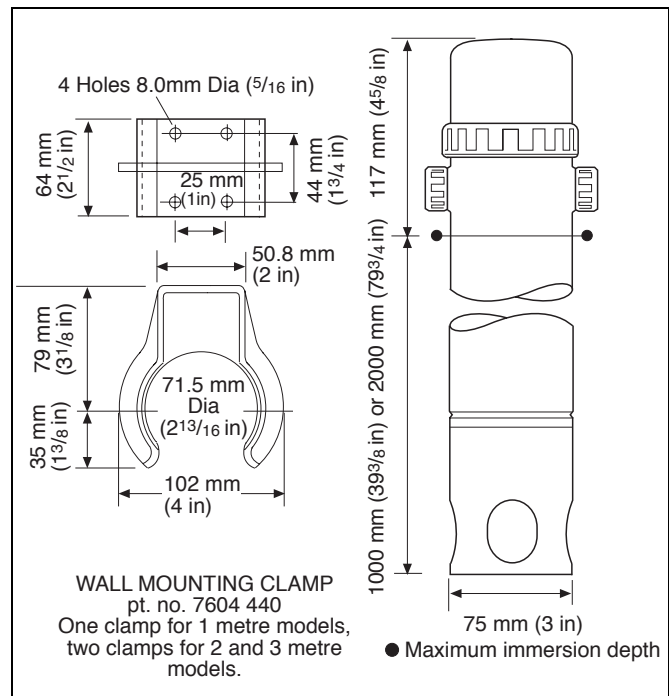

Fig. 3.4 Mounting, Types 7654, 7655, 7656, 7664 and 7665

Adjustable flanges to various standard drilling configurations are also available to mount dip models close to a closed tank wall.

Note. Flanges available are very diverse. Please consult the sales office for details.

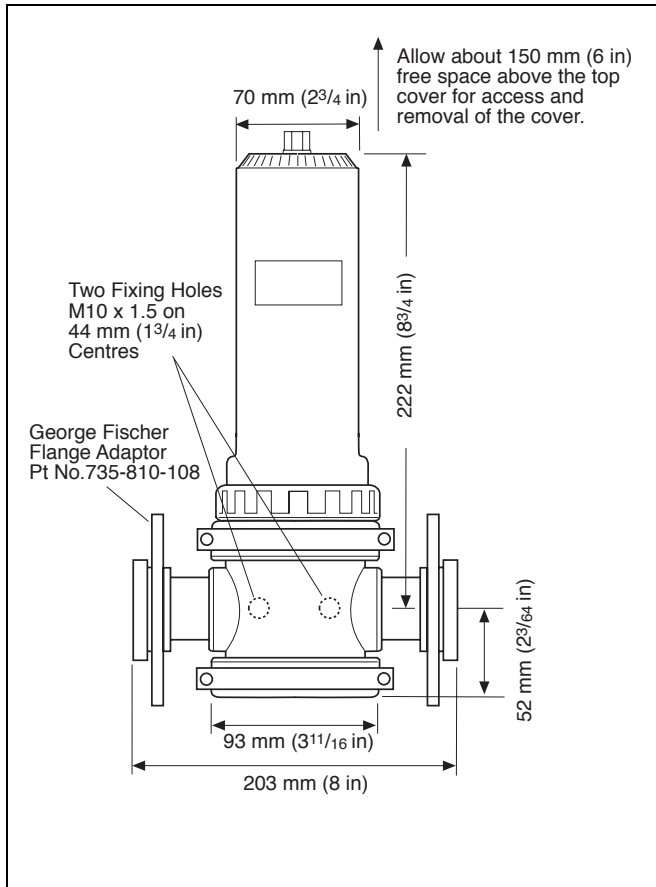

Fig. 3.5 Mounting, Type 7661

3.3 Fitting Electrodes

Note. Ensure that the system cable is fed through the electrode system cover or dip tube, as applicable, before the cable is connected.

Secure the cable in its permanent position, ensuring sufficient free cable at both ends for connection to the electrodes and to the meter.

Caution. To avoid the risk of damp or corrosive air damaging the cable plugs, connect to the electrodes as soon as possible.

3.3.1 Removing the Sensor Holder

Note. Reservoir-fed systems: only follow instructions with respect to Flow/In-Line systems, see section 3.4, page 11 to fit the reservoir assembly.

See Fig. 3.6 for models 7651, 7652, 7660 and 7661, or Fig. 3.7 models 7654, 7655, 7656, 7664 and 7665, to access the sensor holder.

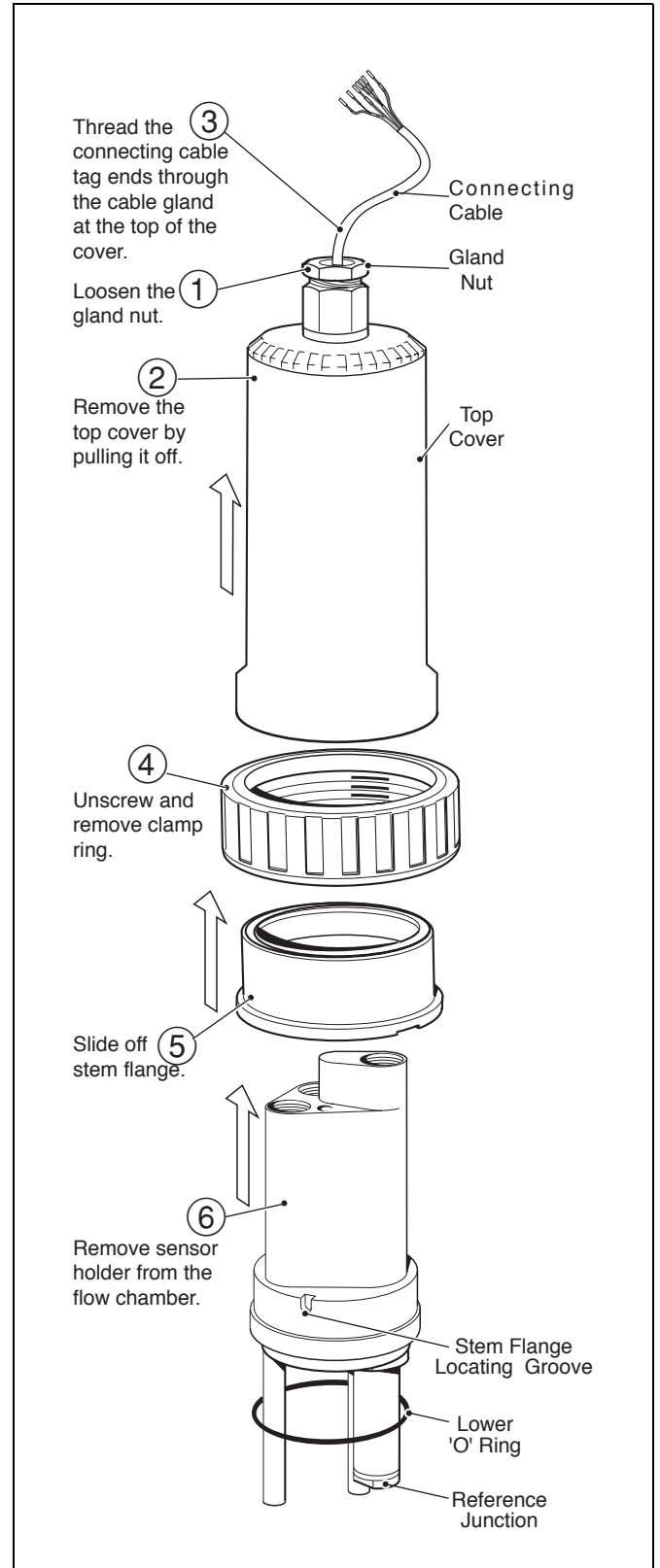

Fig. 3.6 Access to Sensor Holder for Flow and In-line Systems - Models 7651, 7652, 7660 and 7661

Note. If using a cleaning option refer to the appropriate manual (IM/7600-CLN) as the sensor holder and reference electrode are different.

3.3.2 Fitting the Reference Electrode

1. Remove the reference electrode 1730-000 from its box; the box should also contain a bottle of KCl solution (slurry).

Caution. Wear eye protection when filling the reference electrode with KCl solution (slurry). Refer to the appropriate Material Safety Data Sheet for more information.

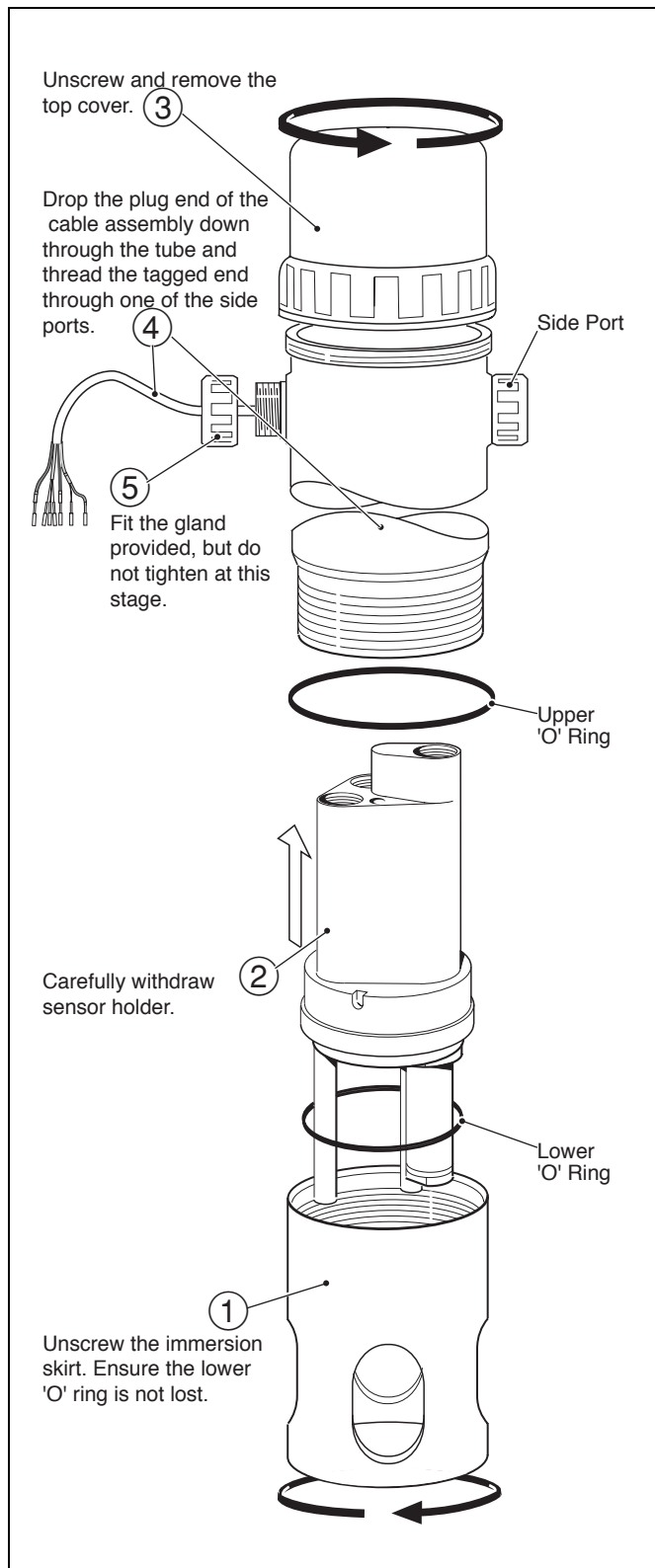

2. Shake the bottle of KCl solution well to ensure it is mixed thoroughly so that the solids are freely dispersed in the solution.
3. Slowly fill the reference chamber with solution through the filling hole (see Fig. 3.8a). Fill in small quantities and shake the bottle frequently to keep the KCl in suspension (the contents of one bottle should fill the reference chamber and allow for displacement when the reference electrode is fitted).
4. Wipe dry the area around the filling hole.
5. Fit the reference electrode **IMMEDIATELY** ensuring that the 'O' ring is fitted over the electrode - see Fig. 3.9.

Note. To ensure correct fitting of the electrode, it may be necessary to clear a path through the slurry in the chamber. Do this using the reference electrode gently in an up-and-down motion to clear a path.

6. When a path has been cleared, position the electrode and screw down firmly to ensure a good seal.
7. Shake the sensor holder to ensure that the KCl slurry reaches the bottom of the chamber.
8. Invert the sensor holder and remove the reference junction (Fig. 3.8). Check the level of the slurry; top up if necessary. Refit reference junction.

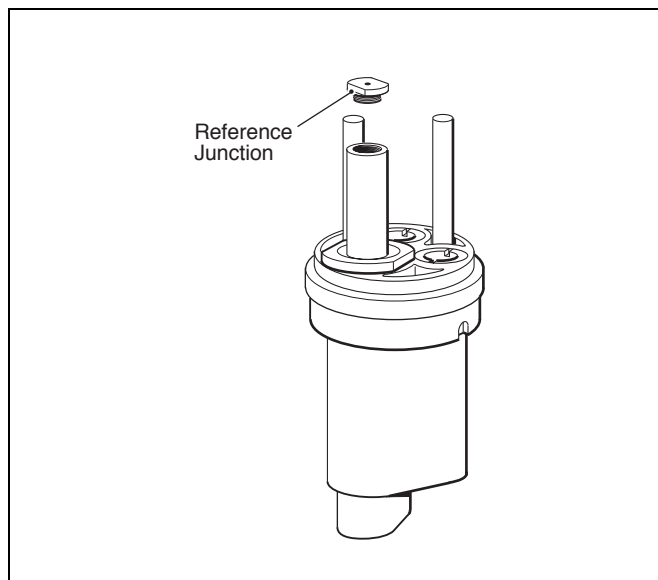

Fig. 3.8 Sealed Types (Electrodes and Temperature Compensator Omitted for Clarity)

Fig. 3.7 Access to Sensor Holder for Dip Systems - Models 7654, 7655, 7656, 7664 & 7665

There are two reference junctions available:

- 1360 180 Small Reference Junction: supplied with all sealed reference electrodes. The junction is suitable for use in general applications where the loss of KCl is minimised and where the pressure can reach 10bar (145 psi).
- 1360 190 Large Reference Junction: supplied with reservoir-fed reference systems to give a reproducible KCl flow rate. The junction can be used on sealed reference system on low conductivity applications to reduce instability problems or on sample where high level of solids that cause rapid blockage of the small junction. The large junction must be used only on flow systems or dip systems operating at atmospheric pressure.

3.3.3 Fitting the Measuring Electrode, and the Temperature Compensator 1750-000 (if required)

Note. If a temperature compensator is not fitted, ensure the blanking plug (Fig. 3.10) is fitted (Redox).

1. Remove the temperature compensator (1750-000) and the measuring electrode from their packaging. If the measuring electrode is a glass electrode, carefully remove and discard protective teat.
2. Fit the electrodes as shown in Fig. 3.9.

3.3.4 Completion Tasks

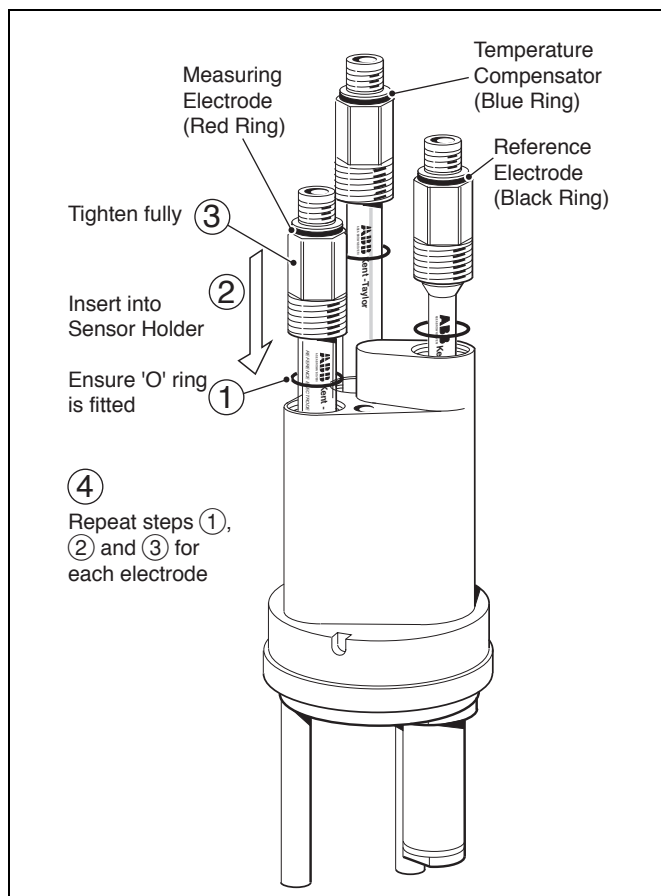

Fig. 3.9 Fitting the Electrodes into the Sensor Holder

Reassemble in the reverse order to that shown in the steps in Fig. 3.6 or Fig. 3.7. Before fitting the Top Cover, however, connect the colour coded electrode cables to the appropriate electrodes - see Fig. 3.11.

Finally, tighten the gland nut to secure the connecting cable.

3.4 Fitting the Reservoir - Models 7651, 7652, 7660 and 7661

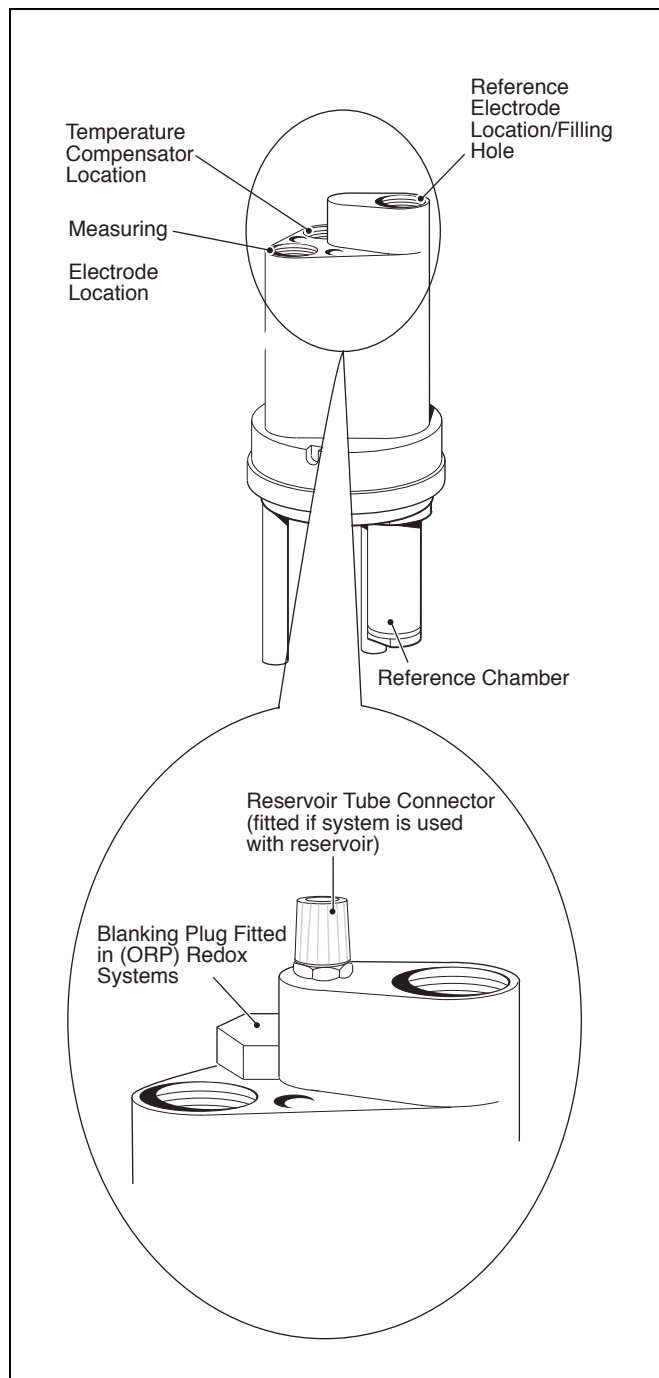

Fig. 3.10 Location of Blanking Plug and Reservoir Tube Connector

Caution. It is vital that the terminations are kept dry at all times.

Note. When fitting or removing the electrode connectors, hold the top section of the connector firmly while rotating the bottom section.

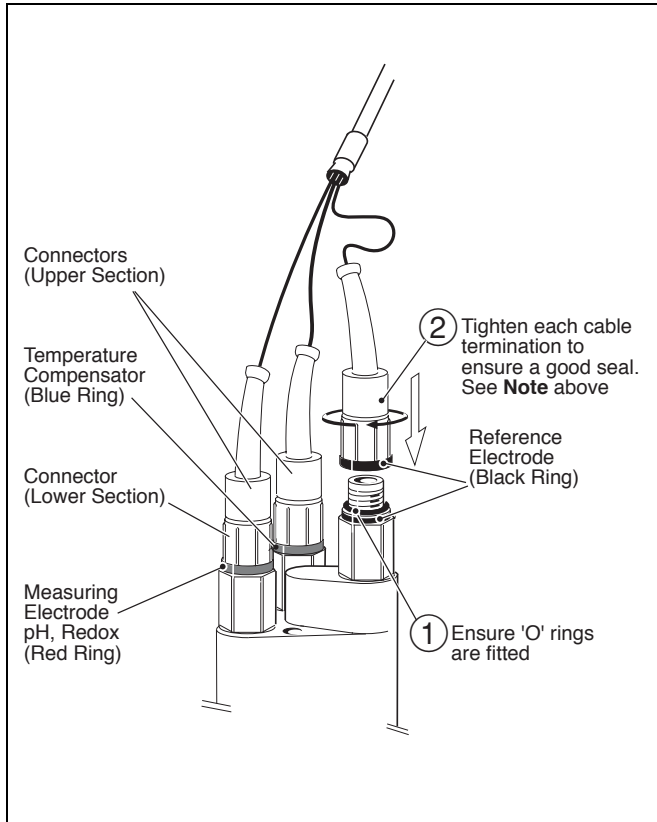

Fig. 3.11 Fitting the Electrode Connectors

The reservoir comes partially assembled as shown in Fig. 3.12a.

Complete the assembly and fill the reservoir as shown in Fig. 3.12b and Fig. 3.12c respectively.

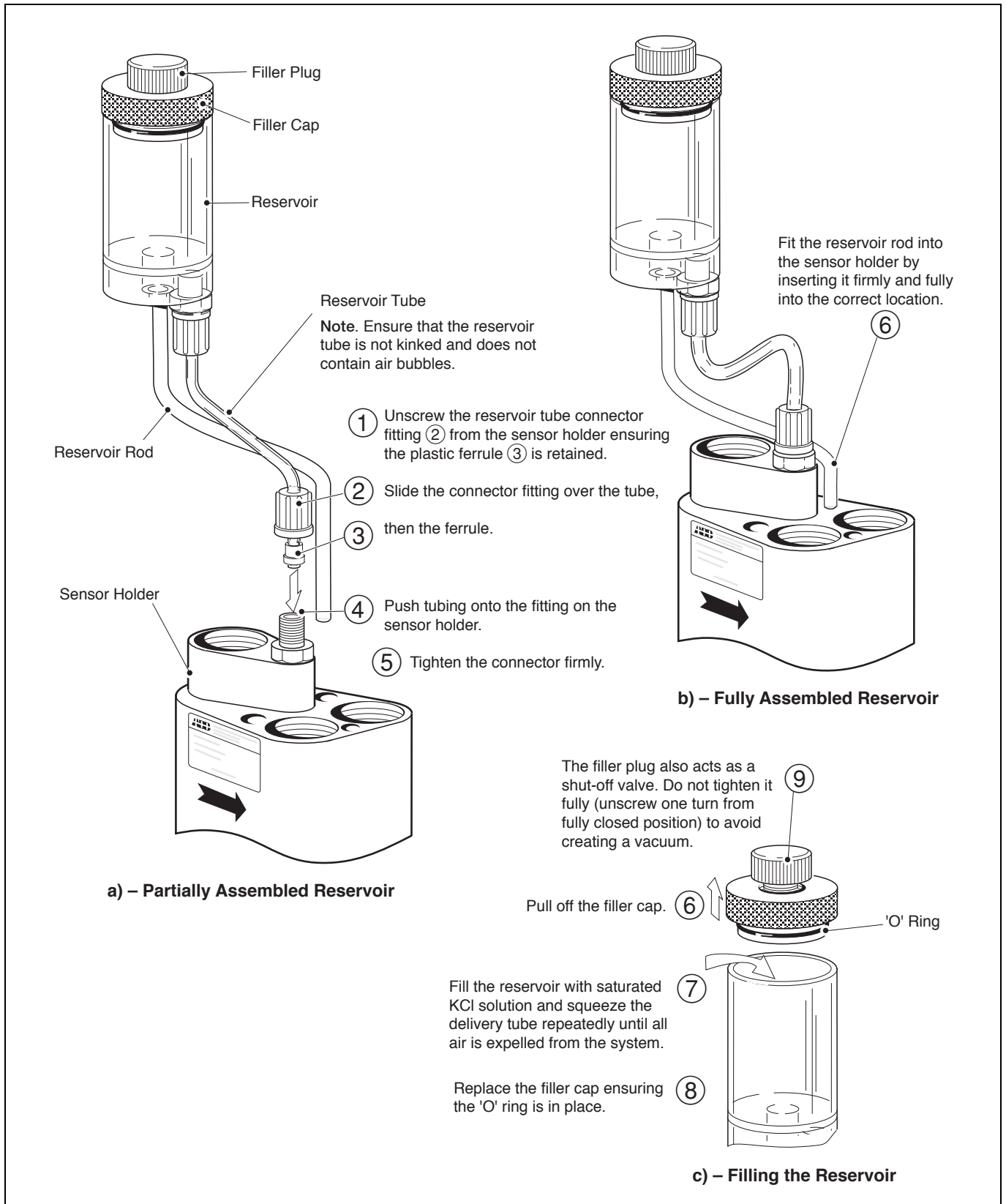
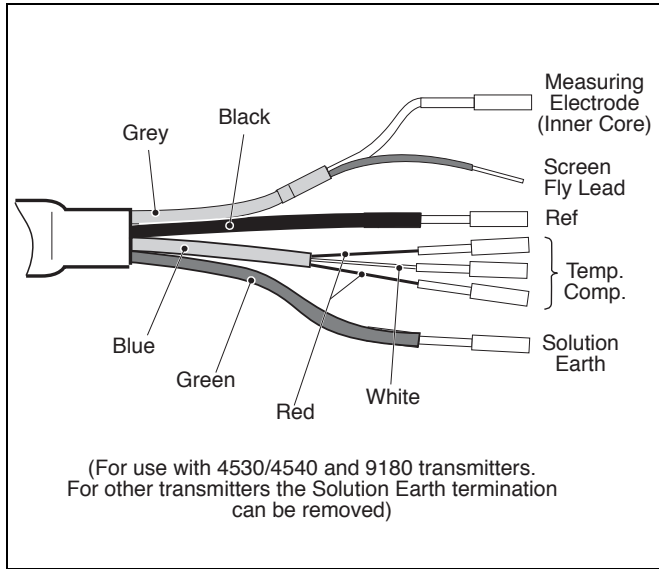

Fig. 3.12 Fitting and Filling the Reservoir (Electrodes and Temperature Compensator Omitted for Clarity)

4 ELECTRICAL INSTALLATION

4.1 Connection to AX, 4500 and 4600 Series Transmitters

System cable connections to the pH meter are shown in Fig. 4.1. For AX and 4600 series transmitters refer to the pH meter instruction manual. For 4500 Series transmitters refer to the list of equivalent connections shown in Table 4.1.



System Cable	4530	4535	4540	4545
Measuring Electrode (inner of coax)	24	24	22	22
Reference (black)	26	26	24	24
Temp. Comp. (red)	1	1	29	29
Temp. Comp. (white)	2	2	30	30
Temp. Comp. (red)	3	3	31	31
Solution Earth (earth)	25	N/A	23	N/A

Table 4.1 Series 4500 Connection Equivalents

Fig. 4.1 System Connections

4.2 Connection to Hazardous Area Systems

Connect the electrode terminals to the junction box supplied - see Fig. 4.2.

Note. Connect together the two red leads from the temperature compensator. Follow the instructions in the intrinsically safe pH measuring system manual for the remainder of the electrical installation.

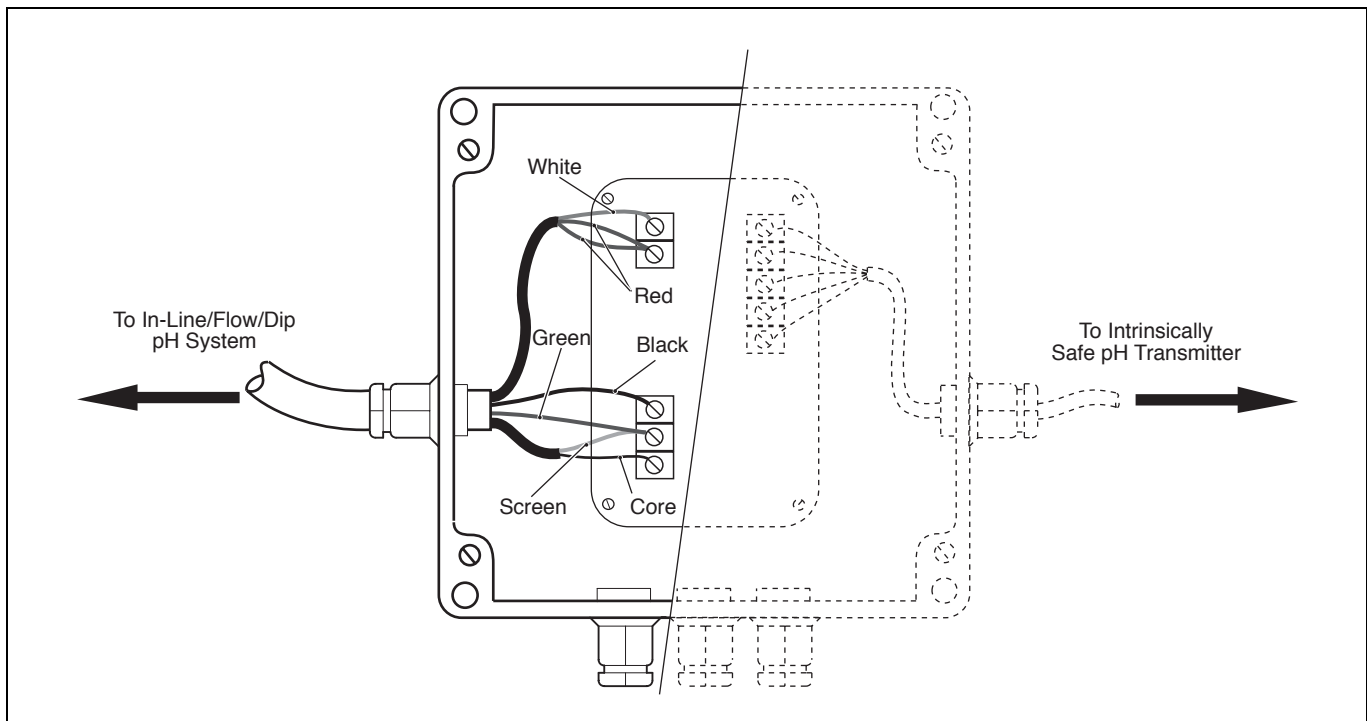

Fig. 4.2 Junction Box Electrode Connections

4.3 Cable Termination

If the provided standard length cable requires shortening, the recommended preparation is as shown in Fig. 4.3.

Strip back the overall cable sheath to measurements as shown and fit suitable sleeves and solder tags to the leads, for connection to the transmitter.

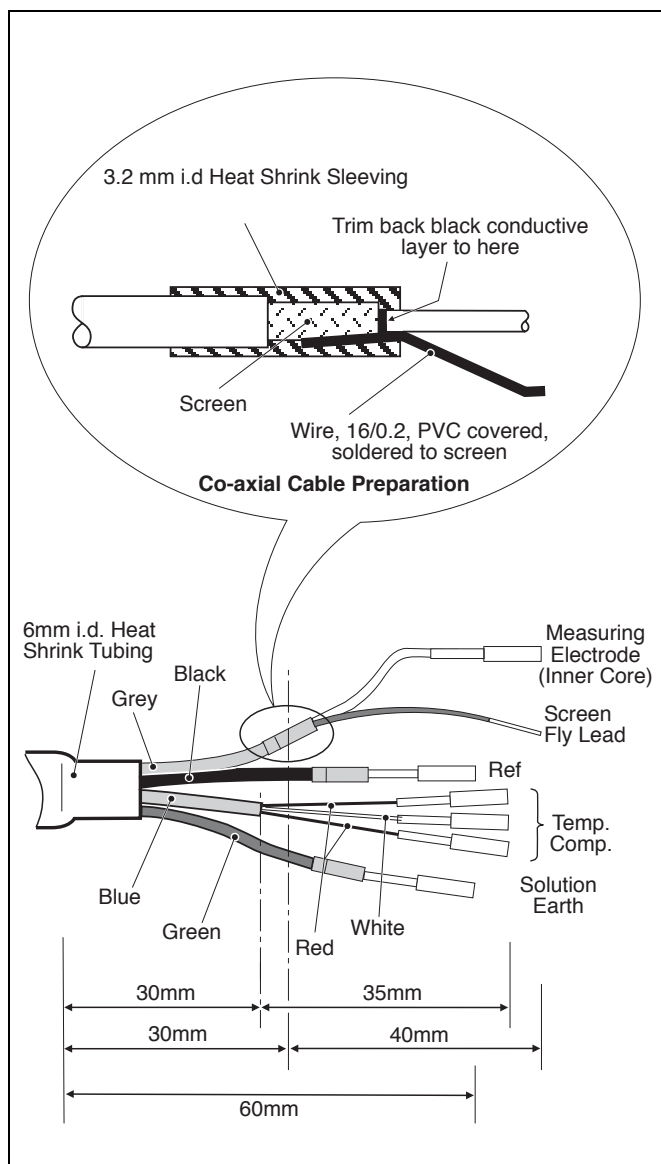

Fig. 4.3 Cable Termination

5 CALIBRATING THE SYSTEM

5.1 General Calibration of Electrodes

When the electrode system has been connected correctly and all electrical connections made to the associated pH transmitter, the system is ready for calibration by immersing the electrodes (using suitably sized beakers) in either:

- A calibration solution (buffer) of known pH value for a single-point calibration.
- or
- Two separate calibration solutions of known pH values for a two point calibration. For electrode systems in use:

1. Remove the electrode from the process or sample.
2. Wash the visible electrode surface with demineralised water.

Refer to the instruction manual for the pH transmitter for full details of the calibration procedure.

Note. Do not use 10pH buffer solutions with Low Resistance Glass pH Electrodes as this results in an error in the slope calculation. These solutions contain a high level of sodium that affects the output of the electrode, due to sodium response interference at high pH values.

5.2 Calibration of Electrodes used in High Purity Water Applications

5.2.1 Monthly Calibration

1. Rinse the electrodes thoroughly with high purity water.
2. Carry out a single-point calibration using a 5-fold diluted 9 or 10pH buffer solution, to adjust for small changes in the Check Reading. If necessary, leave the electrodes in the solution to fully equilibrate at the buffer solution temperature.

Note. These solutions are contaminated easily so they must be freshly prepared from the original solution, used only once and keep solution in a closed container.

5.2.2 3-Monthly Calibration

1. Rinse the electrodes thoroughly with high purity water.
2. Carry out a two-point calibration using normal strength buffer solutions. If necessary, leave the electrodes in the solution to fully equilibrate at the buffer solution temperature.
3. Carry out a single-point calibration as described in the monthly calibration procedure.

6 ROUTINE MAINTENANCE

6.1 'O' Ring Seals

Whenever the electrode system is opened at any point, all 'O' rings (especially the lower sensor holder 'O' ring), seals, washers, etc. should be checked for damage, wear and flexibility, and unserviceable rings must be replaced. Serviceability very much depends on the particular application, but regular checking soon determines an average ring life.

A spare set of 'O' rings is supplied with each system, and replacement 'O' rings, etc. are available in a Service Pack - see section 7, page 18.

6.2 Cleaning

When the performance of the electrodes begins to deteriorate, cleaning may help to restore their original condition. If the cleaning actions described in this section do not eliminate the deterioration, either the glass (or redox) electrode, or the sealed reference electrode or both should be replaced - see section 6.4, page 16.

If the system is fitted with a mechanical or ultrasonic electrode cleaning device, refer to the instruction manual IM/7600-CLN for details of cleaning procedures.

During cleaning, avoid rough handling of the pH glass electrode membrane. Wiping with a soft cloth or tissue soaked in an appropriate solvent to remove the deposit, or washing with a strong jet of water are preferred methods - this can be carried out by removing the electrode holder unit from the process fitting; it should be unnecessary to remove the electrodes from the sensor holder. However, where the following cleaning operation requires an extended period it is advisable to replace the electrode during cleaning with a new one so that there is a minimum interruption to the on-line process measurement.

Warning. Hydrochloric acid is corrosive. Wear appropriate protective clothing. Refer to the appropriate Material Safety Data Sheet for more information.

1. For general sludge and loosely adhering matter wipe the glass membrane with cotton wool soaked in 1.0M hydrochloric acid (or a buffer solution) and then wash in water. Now calibrate the pH meter.
2. For greasy organic deposits, wipe the glass membrane with cotton wool soaked in a detergent and rinse thoroughly. If a sluggish response to pH changes still occurs soak the electrode for a few hours in 0.1M hydrochloric acid (or a buffer solution) and then wash in water.
3. For heavy non-greasy deposits, e.g. rust, dip the electrode briefly in concentrated hydrochloric acid to remove the deposit and wash thoroughly. Soak the electrode for a few hours in 0.1M hydrochloric acid (or a buffer solution) and then wash in water. Very heavy deposits formed during effluent neutralisation are often best removed by using a 1 : 1 mixture of concentrated hydrochloric acid and water. Pepsin digested in hydrochloric acid may also be used for protein removal.
4. The Reference Junction of the reference electrode may be cleaned by washing in water and wiping with a clean cloth.

5. Redox electrodes may be cleaned by any of the previously described methods; they may also be cathodically cleaned as follows:

Warning. Sulphuric acid is corrosive. Wear appropriate protective clothing. Refer to the appropriate Material Safety Data Sheet for more information.

Degrease the electrode, e.g. with a detergent. Connect the redox electrode cable to the negative pole of a 6V battery or power supply. Connect a piece of platinum wire to the positive pole of the battery or power supply, and dip both electrodes into a beaker containing 2 to 5% sulphuric acid solution. Continue electrolysis for approximately 10 minutes. If after this period the bubbles rising from the redox electrode are not small and evenly distributed on the immersed parts of the electrode, repeat the electrolysis.

6.3 Checking the Electrolyte Level

Periodically check the level of electrolyte (about every three months).

For sealed units remove the electrode holder from the system. Refer to Fig. 3.8a. Invert the holder and remove the reference junction. View the electrolyte level through the plug hole and top up if necessary.

6.4 Replacing Electrodes

6.4.1 Measuring Electrodes

If the pH or redox electrode is no longer serviceable (see section 6.5, page 17) fit a new electrode. The procedure is as follows:

1. For a flow system isolate the system to enable safe access to the sensors. In the case of a dip system, remove it from its installed position in the fixing clamp(s).
2. Remove the electrode holder unit from the process fitting (the protective skirt on a dip system), and take out the sensor holder from the bottom end of the electrode holder unit.
3. Replace the electrode with a new one following the steps outlined in Section 3.3.3.
4. Calibrate the pH meter or electrode system as outlined in the pH meter instruction manual.
5. Install the electrode holder unit.

6.4.2 Reference Electrodes

If the reference electrode system is no longer serviceable (see section 6.5, page 17), a new one must be fitted. The procedure for replacing the reference electrode is similar to that for the measuring electrode, as follows:

1. For a flow system isolate the system to enable safe access to the sensors. In the case of a dip system, remove it from its installed position in the fixing clamp(s).
2. Remove the electrode holder unit from the process fitting, and take out the sensor holder from the bottom end of the electrode holder unit.
3. Replace the reference electrode with an appropriate new one, following the steps outlined in Section 3.3.2.

4. Calibrate the complete system as described in the pH meter instruction manual.
5. Install the electrode holder unit.

6.5 Recommended Maintenance of the Company's pH Systems

The following information provides a recommended maintenance procedure and general information for the investigation of problems that may be encountered.

1. Electrode systems used on dirty water applications should be cleaned frequently, perhaps once a week. The cleaner applications may not require cleaning more than once every one or two months.
2. Following the cleaning process calibrate in buffer solutions as often as considered necessary to maintain the required system accuracy. The SLOPE value and CHECK reading of the electrode pair, indicated by the transmitter, is then assessed.
 - a. The SLOPE value is an indication of the glass electrode response to a given change in pH. This is calculated by the AX400, 4500 and 4600 Series pH transmitters and can be displayed.

A glass electrode with a SLOPE value of 95% and above should be considered as functioning well. 92% to 94% is borderline depending on the importance of the application. Less than 92% should be considered as suspect, indicating it requires cleaning, as indicated above, reactivated (i.e. immersed in 0.1M HCl for a few hours), or needs replacing.

- b. The CHECK reading is an indication of the electrical zero of the electrode pair, so it should be checked following a calibration. This can easily be displayed again on the AX400, 4500 and 4600 Series transmitters. The nominal value of the CHECK reading is 7pH, indicating the 0mV equivalent to 7pH. The CHECK reading should be in the range 6 to 8ppH but more importantly should be constant between calibrations and over a period. Any sudden change indicates that the potential of the reference electrode has changed and should be given attention - see 3) following.

Note. SLOPE value and CHECK readings can be affected by low insulation on the electrode terminations. Always check for any evidence of moisture in the electrode terminations.

3. The sealed double junction reference arrangement used on this pH system requires regular maintenance. The frequency of this maintenance depends greatly on the application. Failure to carry out this maintenance changes its mV potential, i.e. CHECK reading, causing drift, open circuit or permanent damage to the reference electrode itself.

Replace the reference junction frequently - every two or three months on 'dirty' applications and low conductivity waters, six months on 'cleaner' applications, or whenever the ceramic becomes discoloured.

The internal potassium chloride slurry in the reference electrode is constantly being depleted in use and is potentially being contaminated by the sample. Whenever the reference junction is replaced (see Fig. 3.8) check the internal filling. Refill the junction if there is evidence of contamination, depletion of the solid KCl, or drying out. This involves draining the contents of the electrode, rinsing, and refilling with fresh KCl slurry.

This procedure ensures that the reference electrode lasts for several years.

There are two reference junctions available:

- 1360 180 Small Reference Junction: supplied with all sealed reference electrodes. The junction is suitable for use in general applications where the loss of KCl is minimised and where the pressure can reach 10bar (145 psi).
- 1360 190 Large Reference Junction: supplied with reservoir-fed reference systems to give a reproducible KCl flow rate. The junction can be used on sealed reference system on low conductivity applications to reduce instability problems or on sample where high level of solids that cause rapid blockage of the small junction. The large junction must be used only on flow systems or dip systems operating at atmospheric pressure.

4. To prevent water leaks and moisture ingress at the termination, the seals must be in good condition. It is recommended that all 'O' rings and cable seals should be replaced every 12 months. The 'O' ring, which is fitted around each electrode, are supplied with replacement electrodes, so it must be replaced at the same time.

6.6 Fault Finding

The most obvious faults are electrode problems. If a successful calibration in buffer solutions is not possible, the most likely cause is the electrodes. However, the best approach is to use a pH simulator such as the Model 2410. This enables simulated pH values to be injected via the detachable cable connectors and checks the integrity of both cable and transmitter.

If satisfactory results are obtained, including the impedance checks, then the fault is either the measuring electrode or the reference electrode - see section 6.4, page 16.

6.7 Loss of Sample

The electrodes must not be allowed to dry out after commissioning the system. If, after commissioning, there is a loss of sample for more than several hours, the electrodes must either be kept wet manually or removed and stored correctly. Drying periods are dependant on ambient conditions.

Caution. Failure to keep the electrodes wet results in a shortened working life of the electrodes.

7 SPARES

7.1 Models 7651, 7652

Top Cover	7650065	(sealed Reference Electrode)
Top Cover	7650064	(reservoir Fed)
Clamp Ring	7600640	
Stem Flange	7600590	
Service Pack	7650040	
Small Reference Junction*	1360180	
Large Reference Junction*	1360190	
Electrode Holder Assembly	7650050	(sealed Reference Electrode)
Filling Soln. 3-Pack	7650039	(saturated KCl)

7.2 Models 7654, 7655, 7656

Electrode Holder Assembly	7650050	(sealed Reference Electrode)
Electrode Holder Assembly	7650056	(for use with mechanical and ultrasonic cleaners)
Service Pack	7650040	
Small Reference Junction*	1360180	
Large Reference Junction*	1360190	
Skirt	7603410	
Filling Soln. 3-Pack	7650039	(saturated KCl)

7.3 Model 7660 (stainless steel)

Top Cover	7650064	
Electrode Holder Assembly	7650051	(reservoir Fed)
Large Reference junction	1360190	
Service Pack	7660040	
Clamp Ring	7600640	
Stem Flange	7600590	
Filling solution 3-Pack	7650039	(saturated KCl)

7.4 Reservoir Spares

Reservoir	7650030	
Tube Connector	0216451	
Large Reference Junction*	1360190	

* There are two reference junctions available:

- 1360 180 Small Reference Junction: supplied with all sealed reference electrodes. The junction is suitable for use in general applications where the loss of KCl is minimised and where the pressure can reach 10bar (145 psi).
- 1360 190 Large Reference Junction: supplied with reservoir-fed reference systems to give a reproducible KCl flow rate. The junction can be used on sealed reference system on low conductivity applications to reduce instability problems or on sample where high level of solids that cause rapid blockage of the small junction. The large junction must be used only on flow systems or dip systems operating at atmospheric pressure.

Notes

PRODUCTS & CUSTOMER SUPPORT

Products

Automation Systems

- for the following industries:
 - Chemical & Pharmaceutical
 - Food & Beverage
 - Manufacturing
 - Metals and Minerals
 - Oil, Gas & Petrochemical
 - Pulp and Paper

Drives and Motors

- AC and DC Drives, AC and DC Machines, AC Motors to 1kV
- Drive Systems
- Force Measurement
- Servo Drives

Controllers & Recorders

- Single and Multi-loop Controllers
- Circular Chart and Strip Chart Recorders
- Paperless Recorders
- Process Indicators

Flexible Automation

- Industrial Robots and Robot Systems

Flow Measurement

- Electromagnetic Flowmeters
- Mass Flowmeters
- Turbine Flowmeters
- Wedge Flow Elements

Marine Systems & Turbochargers

- Electrical Systems
- Marine Equipment
- Offshore Retrofit and Refurbishment

Process Analytics

- Process Gas Analysis
- Systems Integration

Transmitters

- Pressure
- Temperature
- Level
- Interface Modules

Valves, Actuators and Positioners

- Control Valves
- Actuators
- Positioners

Water, Gas & Industrial Analytics Instrumentation

- pH, Conductivity and Dissolved Oxygen Transmitters and Sensors
- Ammonia, Nitrate, Phosphate, Silica, Sodium, Chloride, Fluoride, Dissolved Oxygen and Hydrazine Analyzers
- Zirconia Oxygen Analyzers, Katharometers, Hydrogen Purity and Purge-gas Monitors, Thermal Conductivity

Customer Support

We provide a comprehensive after sales service via a Worldwide Service Organization. Contact one of the following offices for details on your nearest Service and Repair Centre.

United Kingdom

ABB Limited
Tel: +44 (0)1453 826661
Fax: +44 (0)1453 829671

United States of America

ABB Inc.
Tel: +1 775 850 4800
Fax: +1 775 850 4808

Client Warranty

Prior to installation, the equipment referred to in this manual must be stored in a clean, dry environment, in accordance with the Company's published specification.

Periodic checks must be made on the equipment's condition. In the event of a failure under warranty, the following documentation must be provided as substantiation:

1. A listing evidencing process operation and alarm logs at time of failure.
2. Copies of all storage, installation, operating and maintenance records relating to the alleged faulty unit.

ABB has Sales & Customer Support expertise
in over 100 countries worldwide

www.abb.com

The Company's policy is one of continuous product
improvement and the right is reserved to modify the
information contained herein without notice.

Printed in UK (01.07)

© ABB 2007



ABB Limited
Oldends Lane, Stonehouse
Gloucestershire
GL10 3TA
UK
Tel: +44 (0)1453 826661
Fax: +44 (0)1453 829671

ABB Inc.
Analytical Instruments
9716 S. Virginia St., Ste. E
Reno, Nevada 89521
USA
Tel:+1 775 850 4800
Fax:+1 775 850 4808