

AW400 Residual chlorine monitor

For the measurement of Free and Total Residual Chlorine, Chlorine Dioxide or Ozone in water



Total and Free Residual Chlorine Measurement

- add potassium iodide to reagent to convert free chlorine measurement to total chlorine

Reagentless Operation

- reduced operating costs with reagentless operation at a pH of 7.5 or less

Multiple Sensor Input Capability

- reduced installation costs for multiple point monitoring operations

Self Cleaning Sensor Assembly

- prolongs sensor life and maintains accuracy

Fast Response Time

- instant response to changes of residual chlorine, unlike batch/DPD methods

Pressure Regulated Sample Flow

- no additional plumbing required to ensure optimum sample delivery rate and pressure

Introduction

Residual chlorine is one of the most important measurements for the effective monitoring of cooling, potable and industrial water treatment processes. ABB's new AW400 Residual Chlorine Monitoring System incorporates the features our customers need to monitor and control residual chlorine levels accurately and affordably. The design enables users to either connect up to three residual chlorine monitoring sensors to the system or to combine pH, ORP and residual chlorine sensors; thus reducing the cost of each measurement considerably.

Low cost of purchase is only part of the answer to providing value to our customers; low cost of ownership is also required. For the majority of waters with pH lower than 7.5, ABB's residual chlorine monitors can measure free chlorine, chlorine dioxide and ozone without the need for expensive reagents and the manpower needed to maintain those reagents. For residual total chlorine, reagents of Acetic Acid and Potassium Iodide are added with a simple-to-maintain peristaltic pump. This keeps costs low and provides up to 60 days un-supervised operation. The AW400 employs a unique 'Vortex Cleaning' system to clean the electrodes. Unlike many sensors on the market that require problematic electric motors to mix the reagents and sample, as well as keep the electrodes clean, the AW400's Vortex Cleaning System induces a spiral flow of fine corundum sand through the cell to scour the electrodes, thus eliminating the need for electric motors. The AW400 is an easy-to-use device; process connections are simple and the user menus are easy to follow for fast setup.

The AW400 is compatible with ABB's 17XX pH and ORP sensors and can be equipped with PID control for feed-forward dosing applications.

When it comes to meeting our customer's demands for accurate, affordable residual chlorine measurement, ABB's AW400 exceeds expectations.



Measurement Principle

The sensor is an amperometric cell comprising two concentric electrodes; an inner, spiral, gold measuring electrode and an outer copper cylinder – the 'counter-electrode'. Sample water flows into the electrode chamber through nozzles located in the measuring cell. The cell also contains a small amount of a special corundum sand that is circulated by the water and acts as an abrasive on the electrodes, keeping them at peak sensitivity. The AW400 measuring cell is polarized because of the normal potential of these two different metal electrodes in water. When oxidizing substances such as chlorine, chlorine dioxide, ozone or their derivatives are present in the sample between the electrodes, the measuring (gold) electrode is depolarized and the counter electrode (copper electrode) dissolves as Cu^{++} . This electron flow generates a signal (current), that is proportional to the oxidizing agent concentration in the sample. The signal is compensated for temperature variations via software in the AW400 transmitter through a PT100 thermistor.

Applications

Here are just a few of the common residual chlorine level monitoring applications for which the AW400 is ideally suited:

- drinking water
- cooling water for power stations and industrial facilities
- fruit and vegetable disinfection baths
- tertiary treated waste water
- swimming pools and spas

The choice is yours, you choose the disinfectant... we'll measure it! Regardless of the disinfectant used at your site, Chlorine, Chlorine Dioxide, Bromine or Ozone, the ABB AW400 is ready for use; simply select the disinfectant from the user-menu on the monitor.

Non-recommended applications

Meat and poultry 'red water' disinfection baths, saltwater waste waters with high oil/fat contents and processes with fibrous sediment that could plug the water flow through the system are all applications where the use of the AW400 is not recommended.

Specification

Measurement Range

Chlorine, Chlorine Dioxide,
Ozone 0 to 20 ppm (mg/l)

Measurement Mode

Measurement technology Amperometric cell
Measurement interval Continuous

Measurement Performance

Accuracy Unbuffered: 2% or ± 0.01 10ppb, whichever is the greater at pH <7.5
Buffered: 2% or ± 10 ppb, whichever is the greater at <pH 10

Sensitivity 0.001 ppm

Minimum Detection Limit 0.005 ppm

Drift Zero drift: $\pm 1\%$ over 30 days Max.
Span drift: -5% over 30 days Max.

Response Time 90% in less than 90 seconds

Interferences Samples containing high concentrations of metal ions or other strong oxidants may affect analyzer operation

Environmental Data

Ambient Operating Temperature -10°C to $+50^{\circ}\text{C}$

Ambient Operating Humidity 80% RH at 31°C , with linear decrease down to 50% RH at 40°C

Sample Temperature Compensated between 2 and 50°C (36°F and 122°F).

Sample Inlet Pressure 0.2 to 4.0 bar (3 to 60 psi).
For pressures over 4 bar (60 psi) install a pressure reducing valve.
Recommended operating pressure is 2 bar (30 psi)

Sample Outlet Pressure Pressureless

Sample Flow Continuous, 60 - 75 l/hr

Sample pH Value 4 to 7.5 (Buffer feed assembly available for pH greater than 7.5). No correction is needed when measuring chlorine dioxide and ozone.

Maintenance

Maintenance Interval Recommended annual replacement of O-rings and electrodes

Calibration single or two-point manual calibration
Comparison of lab method with process sample or de-chlorinated

Cell Construction Material

Electrodes Gold / Copper

Electrode chamber plexiglas

Differential pressure regulator PVC

Mechanical Data

Ingress Protection

Transmitter IP65

Measurement Cell IP64

Sample connections

Inlet/Outlet: $3/8"$ OD polyethylene or flexible PVC tubing

Electrical

Mains voltage 115 Vac, $\pm 10\%$, 50/60 Hz
230 Vac, $\pm 10\%$, 50/60 Hz

Maximum Consumption 20 VA

Certifications

CE

Installation Guidelines

The AW400 performs best when installed following these simple guidelines:

1. Do not allow the cell to be exposed to direct sunlight.
2. Use a sampling point that is significant for the process control.
3. Allow sufficient access for maintenance operations.
4. Install in an area that is completely free of vibration.
5. Install in an area that is as far as possible from rotating or electrical commutation devices.
6. Ensure air bubbles in the sample are kept to a minimum. Frequent and large air bubbles will make the reading unstable.
7. Ensure calibration is performed on the complete system i.e. the monitor and measuring cell(s).
8. Use polyethylene or PVC tubing for delivery of the water sample.
9. Do not shorten the soft overflow tube and ensure it can drain freely without back pressure.

Note. It is advisable that sample drain into a non-metallic pipe due to the corrosive nature of chlorinated, ozonated and bromated waters.

Dimensions

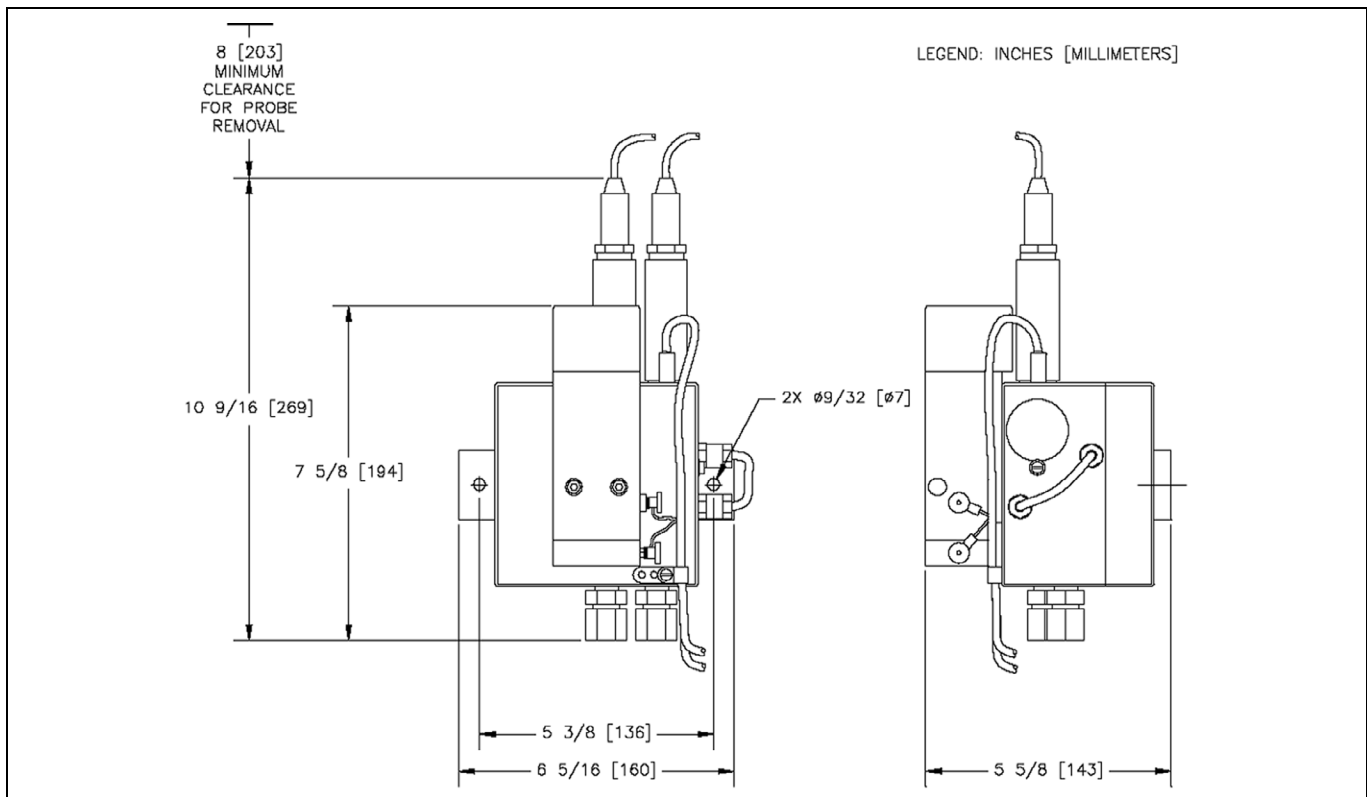

Mounting Dimensions – AW400 Cell

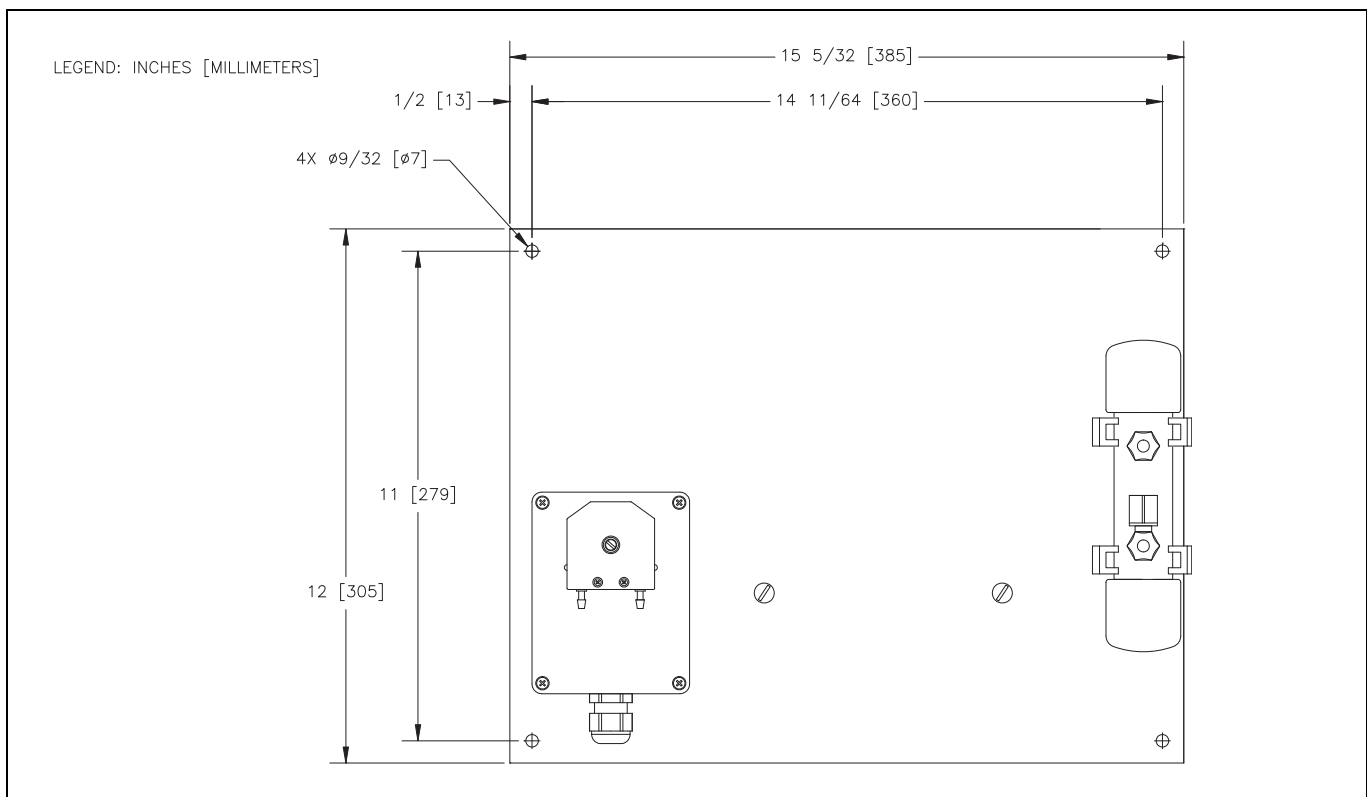

Mounting Dimensions – Reagent Feed Pump

AW400
Residual Chlorine Monitor

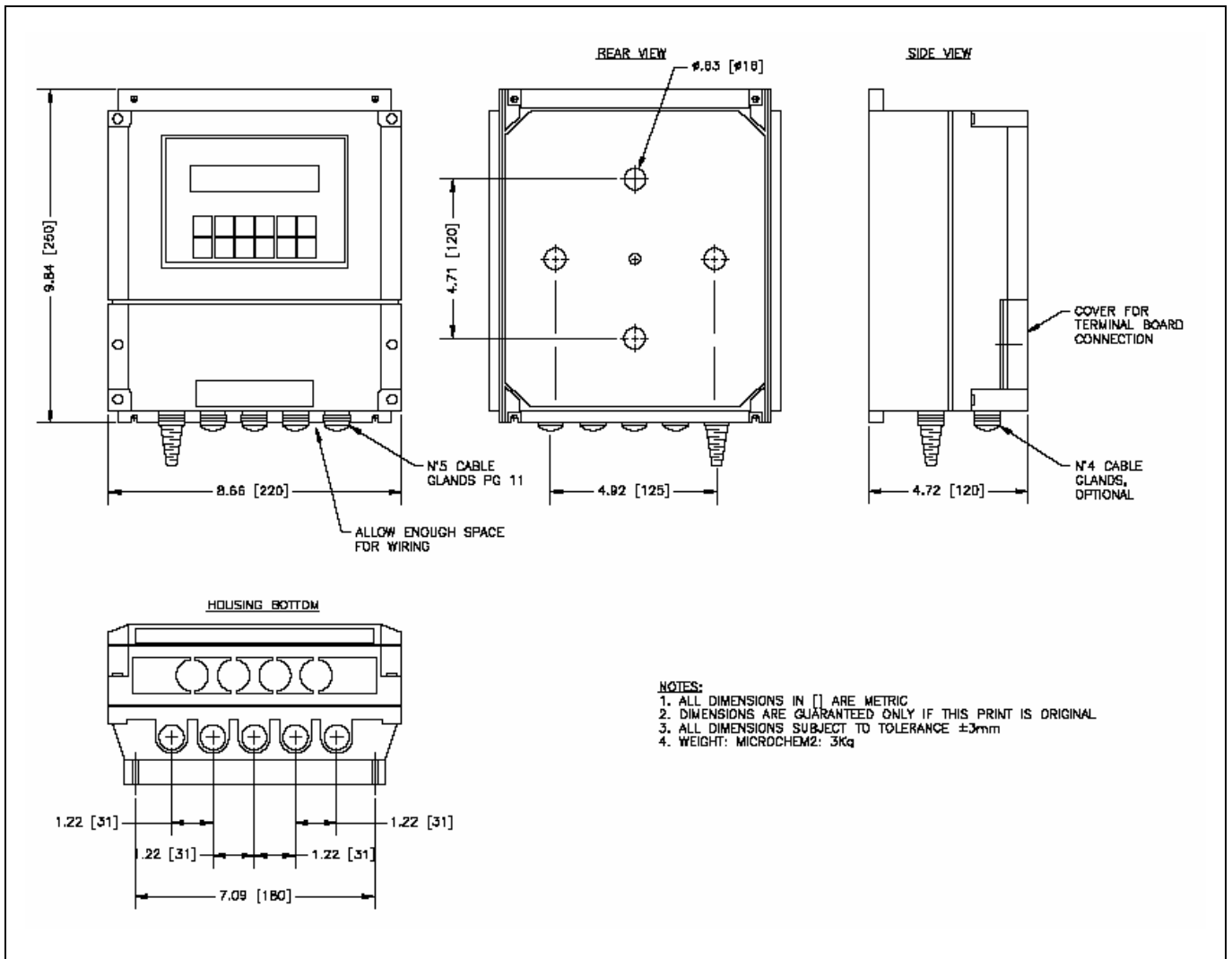

Mounting Dimensions – Transmitter

AW400
Residual chlorine monitor

Ordering Information

Residual Chlorine Monitor	AW4	XX/	X	X	X	X
Transmitter Type						
Transmitter		01				
Transmitter with PID Control (Channel 1 only)		02				
Sensor Type Channel 1						
Chlorine Cell			1			
Sensor Type Channel 2						
No second input channel				0		
Chlorine Cell				1		
pH				6		
ORP				7		
Additional 4-20mA input/output (re-transmission or flow input)				8		
Sensor Type Channel 3						
No third input channel					0	
Chlorine Cell					1	
pH					6	
ORP					7	
Transmitter Voltage						
115V AC 50/60 Hz						1
230V AC 50/60 Hz						2

Accessories

Residual Chlorine Reagent Feeder Assemblies*

Reagent Feeder Assembly (Free Chlorine 115V AC) AW401 011

Reagent Feeder Assembly (Free Chlorine 230V AC) AW401 012

Reagent Feeder Assembly (Total Chlorine 115V AC) AW401 013

Reagent Feeder Assembly (Total Chlorine 230V AC) AW401 014

*Comes complete with tubing and reagent bottles

Benefits Summary

- **Total and Free Residual Chlorine Measurement**
 - add potassium iodide to reagent to convert free chlorine measurement to total chlorine
- **Reagentless Operation**
 - reduced operating costs with reagentless operation at a pH of 7.5 or less
- **Multiple Sensor Input Capability**
 - reduced installation costs for multiple point monitoring operations
- **Self Cleaning Sensor Assembly**
 - prolongs sensor life and maintains accuracy
- **Fast Response Time**
 - instant response to changes of residual chlorine, unlike batch/DPD methods
- **Pressure Regulated Sample Flow**
 - no additional plumbing required to ensure optimum sample delivery rate and pressure
- **PID Control Available**
 - no costly separate controllers needed
- **Field Changeable Configuration**
 - easily reconfigured in the field from a single input device to a two or three input device
- **Minimal Sample Consumption**
 - less than 1 liter (0.22 galls) per minute flow rate required for accurate operation
- **Automatic Temperature Compensation**
 - ensures accuracy and repeatability

Contact us

ABB Limited

Process Automation

Oldends Lane
Stonehouse
Gloucestershire GL10 3TA
UK

Tel: +44 1453 826 661

Fax: +44 1453 829 671

ABB Inc.

Process Automation

125 E. County Line Road
Warminster
PA 18974
USA

Tel: +1 215 674 6000

Fax: +1 215 674 7183

www.abb.com

Note

We reserve the right to make technical changes or modify the contents of this document without prior notice. With regard to purchase orders, the agreed particulars shall prevail. ABB does not accept any responsibility whatsoever for potential errors or possible lack of information in this document.

We reserve all rights in this document and in the subject matter and illustrations contained therein. Any reproduction, disclosure to third parties or utilization of its contents in whole or in parts – is forbidden without prior written consent of ABB.

Copyright© 2010 ABB

All rights reserved

3KXA843401R1001

DS/AW400-EN Rev. D 12.2010