



ABB

The Company

We are an established world force in the design and manufacture of instrumentation for industrial process control, flow measurement, gas and liquid analysis and environmental applications.

As a part of ABB, a world leader in process automation technology, we offer customers application expertise, service and support worldwide.

We are committed to teamwork, high quality manufacturing, advanced technology and unrivalled service and support.

The quality, accuracy and performance of the Company's products result from over 100 years experience, combined with a continuous program of innovative design and development to incorporate the latest technology.

The UKAS Calibration Laboratory No. 0255 is just one of the ten flow calibration plants operated by the Company and is indicative of our dedication to quality and accuracy.

EN ISO 9001:2000



Cert. No. Q 05907

EN 29001 (ISO 9001)



Lenno, Italy – Cert. No. 9/90A

Stonehouse, U.K.



0255

Electrical Safety

This equipment complies with the requirements of CEI/IEC 61010-1:2001-2 "Safety requirements for electrical equipment for measurement, control, and laboratory use". If the equipment is used in a manner NOT specified by the Company, the protection provided by the equipment may be impaired.

Symbols

One or more of the following symbols may appear on the equipment labelling:

	Warning – Refer to the manual for instructions
	Caution – Risk of electric shock
	Protective earth (ground) terminal
	Earth (ground) terminal

	Direct current supply only
	Alternating current supply only
	Both direct and alternating current supply
	The equipment is protected through double insulation

Information in this manual is intended only to assist our customers in the efficient operation of our equipment. Use of this manual for any other purpose is specifically prohibited and its contents are not to be reproduced in full or part without prior approval of the Technical Publications Department.

Health and Safety

To ensure that our products are safe and without risk to health, the following points must be noted:

1. The relevant sections of these instructions must be read carefully before proceeding.
2. Warning labels on containers and packages must be observed.
3. Installation, operation, maintenance and servicing must only be carried out by suitably trained personnel and in accordance with the information given.
4. Normal safety precautions must be taken to avoid the possibility of an accident occurring when operating in conditions of high pressure and/or temperature.
5. Chemicals must be stored away from heat, protected from temperature extremes and powders kept dry. Normal safe handling procedures must be used.
6. When disposing of chemicals ensure that no two chemicals are mixed.

Safety advice concerning the use of the equipment described in this manual or any relevant hazard data sheets (where applicable) may be obtained from the Company address on the back cover, together with servicing and spares information.

CONTENTS

Section	Page	Section	Page
1 INTRODUCTION	2	6 START UP AND OPERATION	15
2 MECHANICAL INSTALLATION	3	6.1 Instrument Start-up	15
2.1 Siting Requirements	3	6.2 Operation – Dissolved Oxygen Measurement Mode	16
2.1.1 Instruments	3	6.2.1 Operation Page	16
2.1.2 Dissolved Oxygen Flowcell	3	6.2.2 Calibration Page	17
2.2 Mounting the Instrument	4	7 PROGRAMMING AND ELECTRICAL CALIBRATION	18
2.2.1 Wall-mounted Instrument	4	7.1 Access to Secure Parameters	18
2.2.2 Panel-mounted Instrument	4	7.2 Select Language Page	18
2.3 Installing the Dissolved Oxygen Flowcell	6	7.3 Set Up Parameters Page	19
2.3.1 Flowcell Dimensions	6	7.4 Set Up Outputs Page	20
2.3.2 System Design Options	6	7.5 Electrical Calibration	22
2.3.3 Connecting the Sample Lines	6	7.5.1 Equipment Required	22
3 ELECTRICAL CONNECTIONS	7	7.6 Preparation	22
3.1 Access to Terminals	7	7.7 Electrical Calibration Page	23
3.1.1 Wall-mounted Instruments	7	8 SIMPLE FAULT FINDING	24
3.1.2 Panel-mounted Instruments	7	8.1 Maintenance	24
3.2 Connections, General	8	8.1.1 Cleaning/Changing the Sensor	24
3.2.1 Relay Contact Protection and Interference Suppression	8	8.2 Error Messages	25
3.3 Wall-mounted Instrument Connections	9	8.3 Low Sensor Output or no Response to D.O. Changes	25
3.4 Panel-mounted Instrument Connections	10	9 SPECIFICATION	26
3.5 Selecting the Mains Voltage	11	10 SPARES	28
3.5.1 Wall-mounted Instrument	11		
3.5.2 Panel-mounted Instrument	11		
4 SETTING UP	12		
4.1 Fitting the Dissolved Oxygen Sensor	12		
4.2 Connecting the Flowcell	13		
5 CONTROLS AND DISPLAYS	14		
5.1 Displays	14		
5.2 Switch Familiarization	14		

1 INTRODUCTION

This manual describes how to install and operate the 9437 Low Level Dissolved Oxygen Monitoring system. Fig. 1.1 shows a schematic of the system.

The Dissolved Oxygen (D.O.) transmitters and associated flowcell have been designed for continuous monitoring and control of power station boiler feed water/steam condensate.

The 4641 transmitter is a wall-mounted instrument and the 4646 model is a panel-mounted, 1/4 DIN-sized instrument. Both instruments have a single programmable D.O. input channel, and a single temperature input channel. The sample temperature is sensed by a Pt1000 resistance thermometer incorporated in the flowcell.

Instrument operation and programming is via four tactile membrane switches located on the front panel. Programmed functions are protected from unauthorized alteration by a five-digit security code.

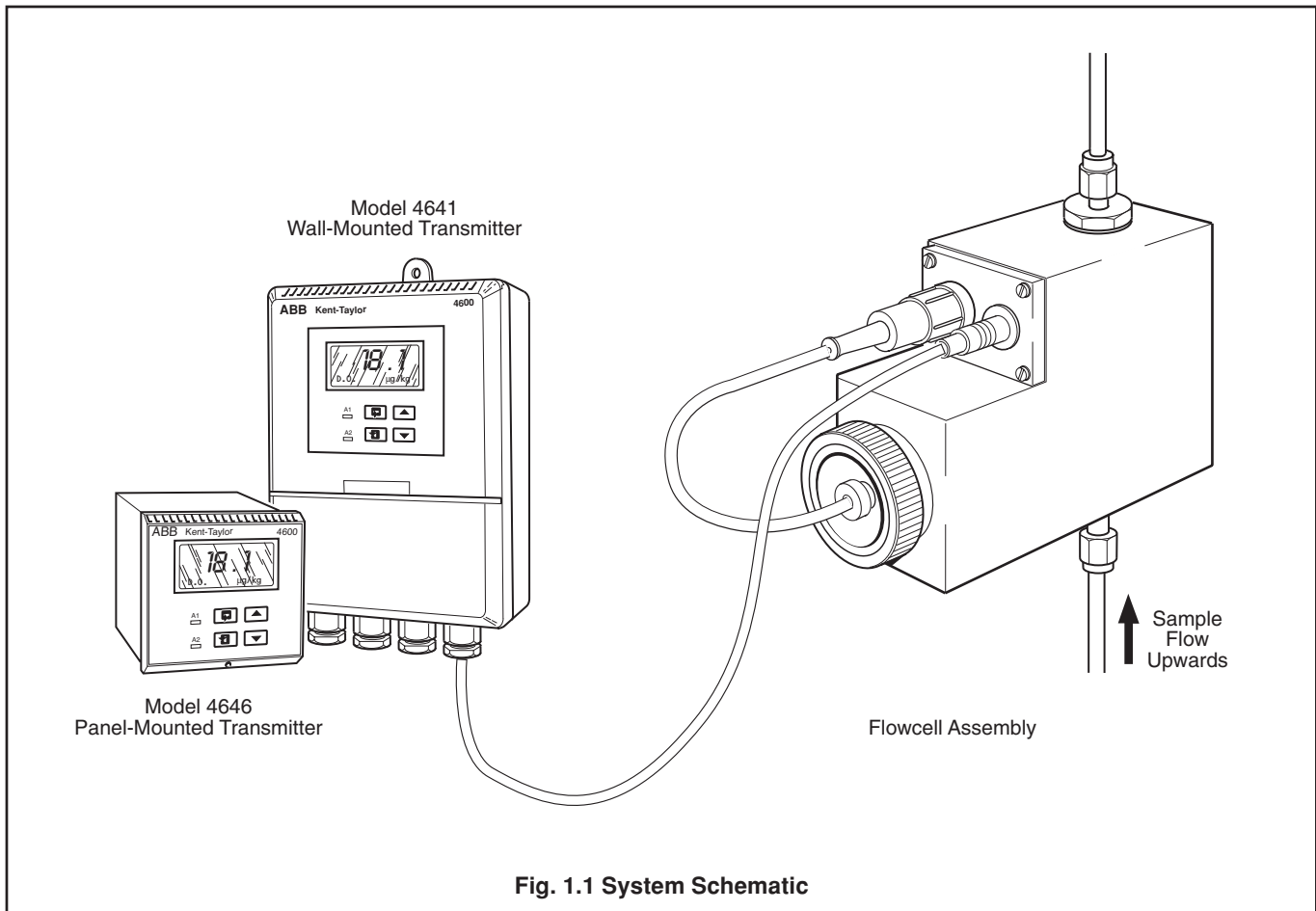

2.1 Siting Requirements

2.1.1 Instruments – Fig. 2.1

Caution.

- Mount instruments in a location free from excessive vibration.
- Mount away from harmful vapors and/or dripping fluids.

Information. It is preferable to mount the transmitter at eye level thus allowing an unrestricted view of the front panel displays and controls

2.1.2 Dissolved Oxygen Flowcell – Fig 2.8

Allow sufficient clearance (200 mm all around) for easy removal of the flowcell assembly for maintenance if required – see Section 2.3.1 for overall dimensions of units.

Note. To eliminate the risk of bubbles accumulating at the sensor, and hence giving erroneous readings, the flowcell assembly must be mounted vertically as shown in Fig. 2.8.

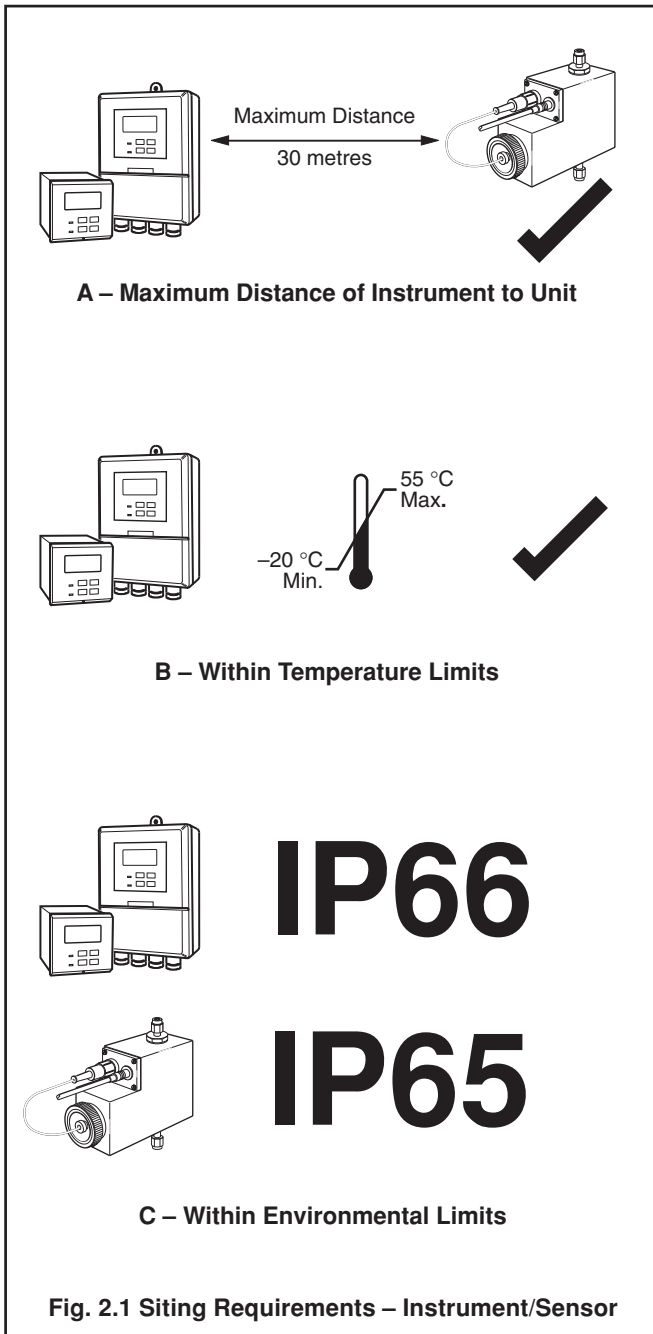
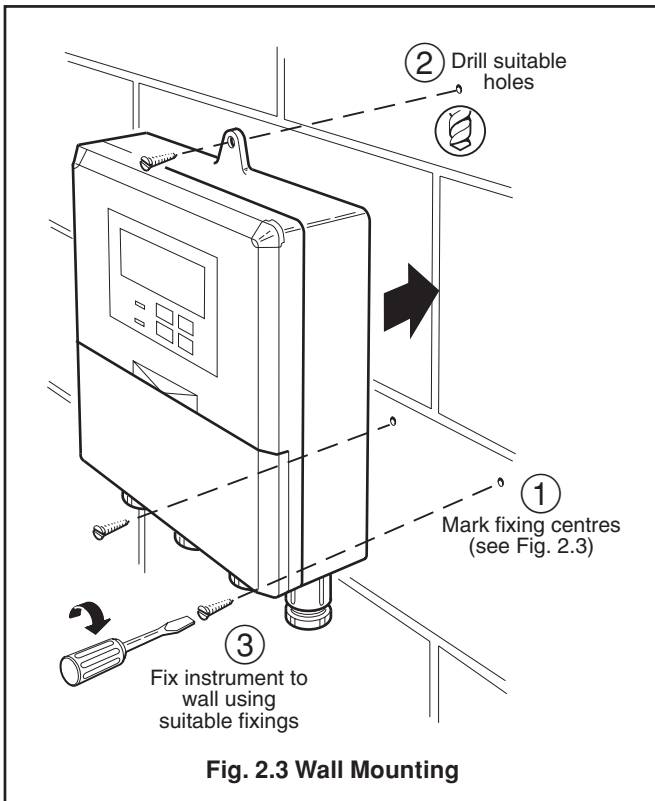
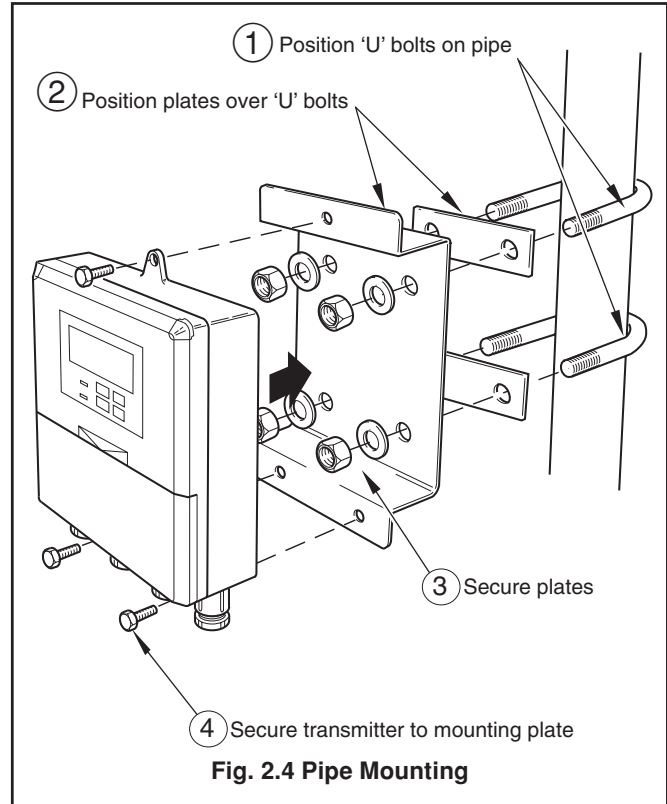
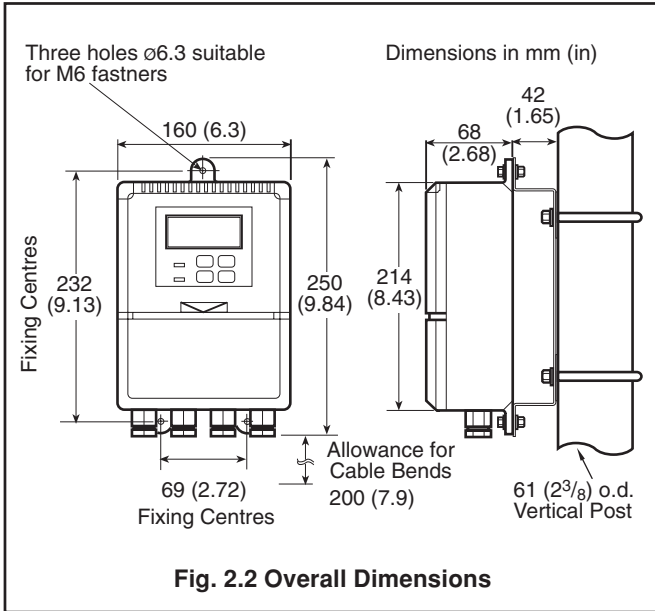

Fig. 2.1 Siting Requirements – Instrument/Sensor

...2 MECHANICAL INSTALLATION

2.2 Mounting the Instrument

2.2.1 Wall-mounted Instrument – Figs. 2.2, 2.3 and 2.4



2.2.2 Panel-mounted Instrument – Figs. 2.5 and 2.6

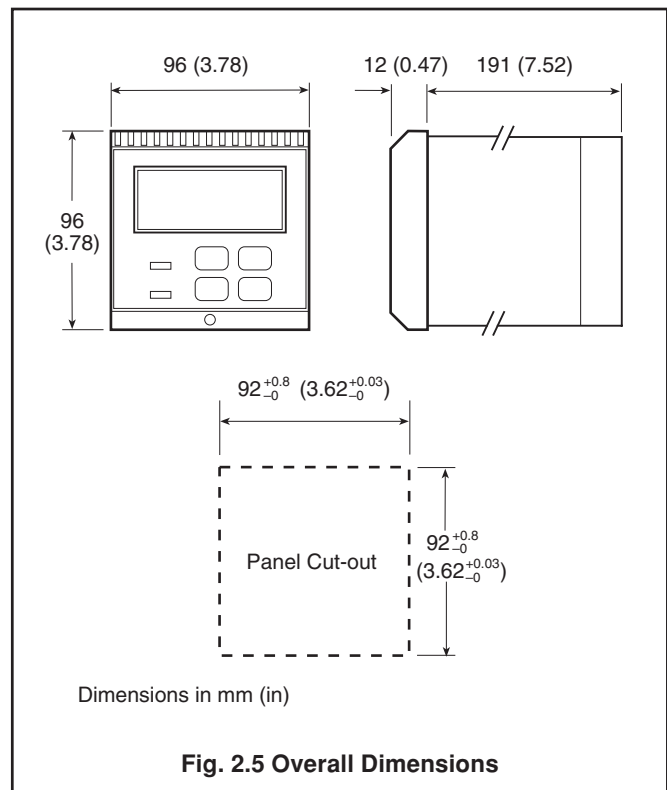

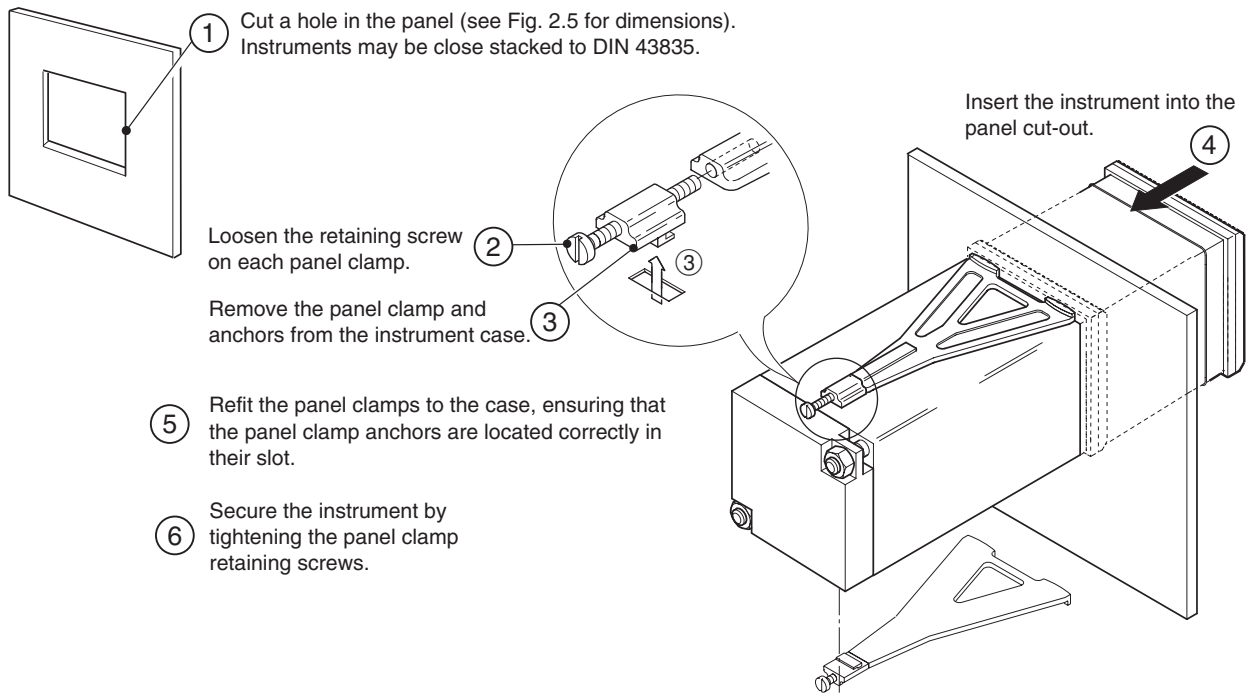

Fig. 2.6 Panel Mounting

...2 MECHANICAL INSTALLATION

2.3 Installing the Dissolved Oxygen Flowcell

2.3.1 Flowcell Dimensions (without couplings fitted)

Dimension	Value in mm (in.)
Height	97.0 (3.82)
Width	80.0 (3.15)
Depth	108.6 (4.28)

**Table 2.1 Flowcell Dimensions
(without couplings fitted)**

2.3.2 System Design Options – Fig. 2.7

Fig. 2.7A shows a simple system with a sample line isolation valve (V1) and a flowmeter installed. The dissolved oxygen sensor is removed from the flowcell for calibration in air – see Section 6.2.2.

The alternative, and recommended, system is shown in Fig. 2.7B. Here the dissolved oxygen sensor remains in the flowcell during calibration in air. An extra valve (V2) is fitted to drain the sample from the flowcell prior to calibration.

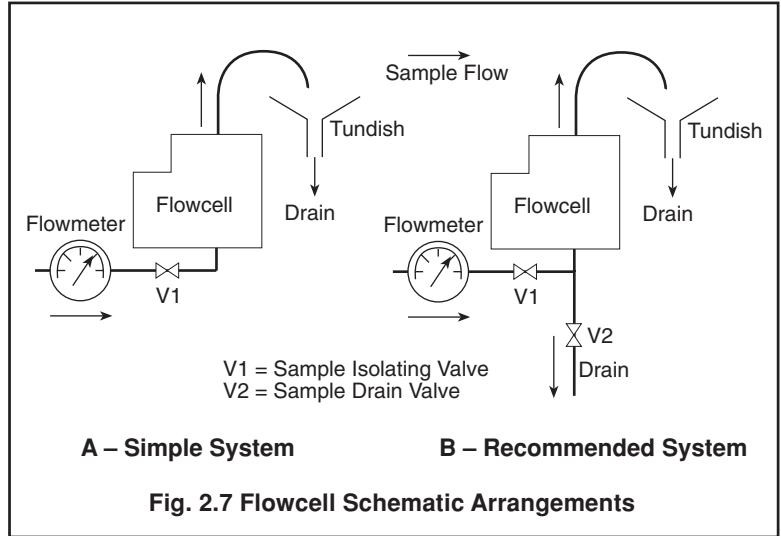

Fig. 2.7 Flowcell Schematic Arrangements

Note.

- The sample flowrate must be between 100 and 500 ml/min.
- The Company recommends that stainless steel tubing is used.

2.3.3 Connecting the Sample Lines – Fig. 2.8

Mount the flowcell vertically as shown in Fig. 2.8A. Connect the sample inlet and outlet tubes as shown in Fig. 2.8B.

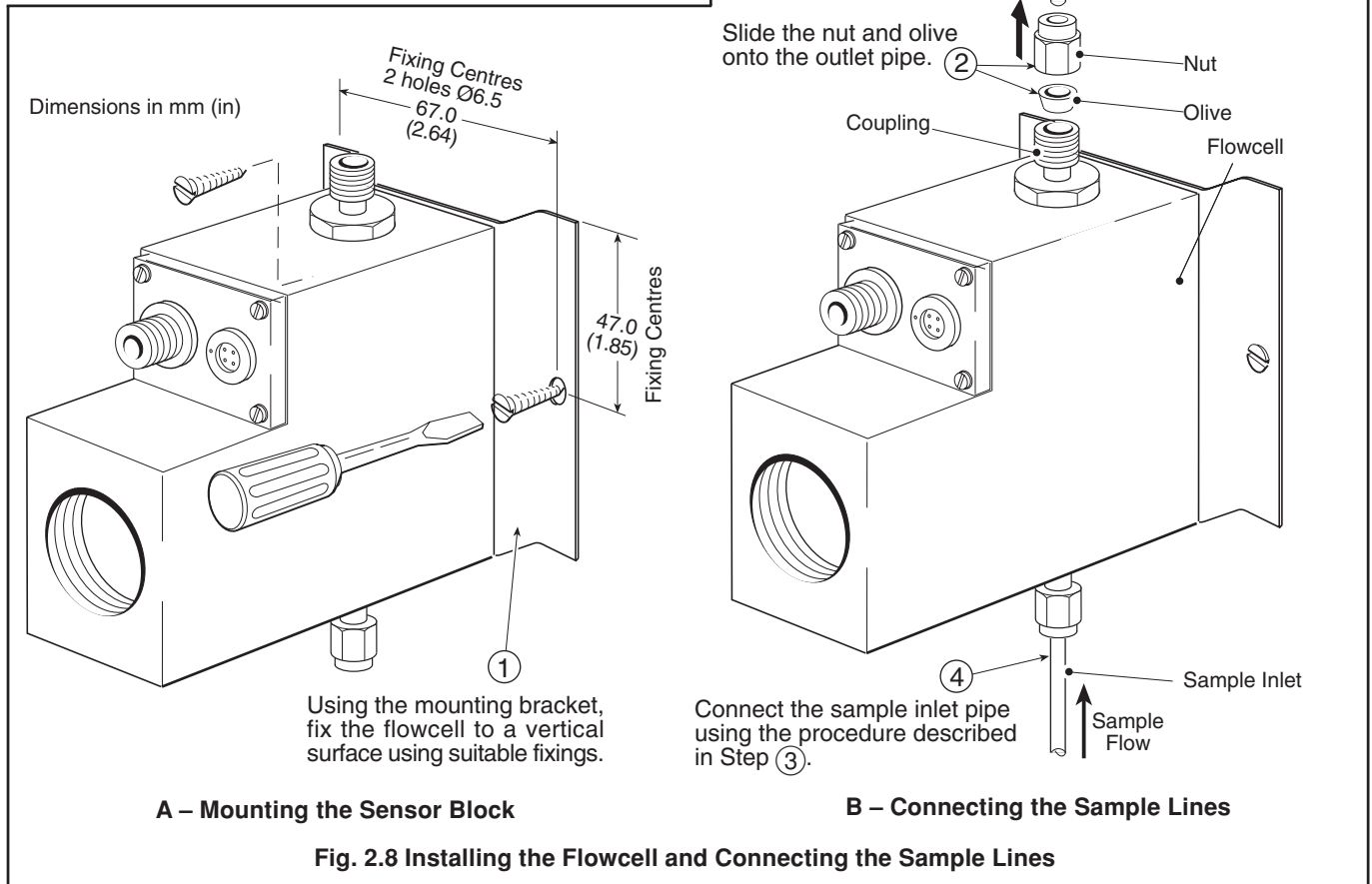

Fig. 2.8 Installing the Flowcell and Connecting the Sample Lines

Warning.

- Before making any connections, ensure that the power supply, any high voltage-operated control circuits and high common mode voltage are switched off.
- Although certain instruments are fitted with internal fuse protection, a suitably rated external protection device, e.g. fuse or miniature circuit breaker (m.c.b.), must also be fitted by the installer.

3.1 Access to Terminals

3.1.1 Wall-mounted Instruments – Fig. 3.1

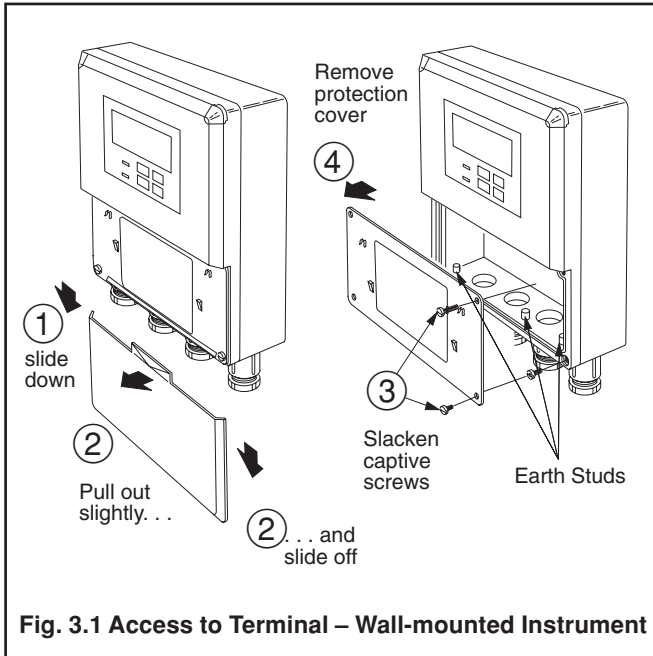

3.1.2 Panel-mounted Instruments – Fig. 3.2

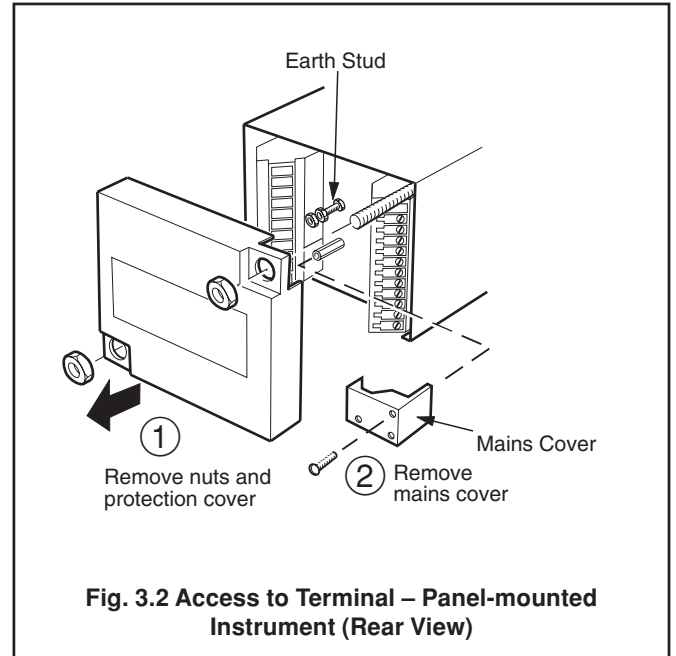

...3 ELECTRICAL CONNECTIONS

3.2 Connections, General

Information.

- **Earthing (grounding)** – stud terminals are fitted to the transmitter case for bus-bar earth (ground) connection – see Fig. 3.1 or 3.2.
- **Cable lengths** – The cable length between the flowcell and the electronics unit is provided as ordered, and suitably terminated at both ends.
- **Cable routing** – always route the signal cable and mains-carrying/relay cables separately, ideally in earthed metal conduit.

Ensure that the cables enter the transmitter through the glands nearest the appropriate screw terminals and are short and direct. Do not tuck excess cable into the terminal compartment.
- **Cable glands & conduit fittings** – ensure a moisture-tight fit when using cable glands, conduit fittings and blanking plugs/bungs (M20 holes). The M16 glands ready-fitted to wall-mounted instruments accept cable of between 4 and 7 mm diameter.
- **Relays** – the relay contacts are voltage-free and must be appropriately connected in series with the power supply and the alarm/control device which they are to actuate. Ensure that the contact rating is not exceeded. Refer also to Section 3.2.1 for relay contact protection details when the relays are to be used for switching loads.
- **Retransmission output** – Do not exceed the maximum load specification for the selected current retransmission range – see Section 8.

Since the retransmission output is isolated the –ve terminal **must** be connected to earth (ground) if connecting to the isolated input of another device.

3.2.1 Relay Contact Protection and Interference Suppression – Fig. 3.3

If the relays are used to switch loads on and off, the relay contacts can become eroded due to arcing. Arcing also generates radio frequency interference (RFI) which can result in instrument malfunction and incorrect readings. To minimize the effects of RFI, arc suppression components are required; resistor/capacitor networks for a.c. applications or diodes for d.c. applications. These components can be connected either across the load or directly across the relay contacts. On 4600 Series instruments the RFI components must be fitted to the relay terminal block along with the supply and load wires – see Fig. 3.3.

For **a.c. applications** the value of the resistor/capacitor network depends on the load current and inductance that is switched. Initially, fit a 100R/0.022 μ F RC suppressor unit (part no. B9303) as shown in Fig. 3.3A. If the instrument malfunctions (incorrect readings) or resets (display shows 88888) the value of the RC network is too low for suppression – an alternative value must be used. If the correct value cannot be obtained, contact the manufacturer of the switched device for details on the RC unit required.

For **d.c. applications** fit a diode as shown in Fig. 3.3B. For general applications use an IN5406 type (600 V peak inverse voltage at 3 A – part no. B7363)

Note. For reliable switching the minimum voltage must be greater than 12 V and the minimum current greater than 100 mA.

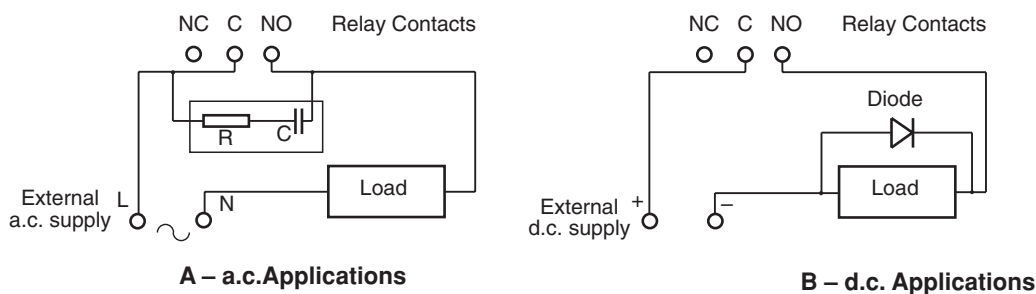

Fig. 3.3 Relay Contact Protection

3.3 Wall-mounted Instrument Connections – Fig. 3.4

Note. Refer to Fig. 3.1 for Access to Terminals.

Caution. Slacken terminal screws fully before making connections.

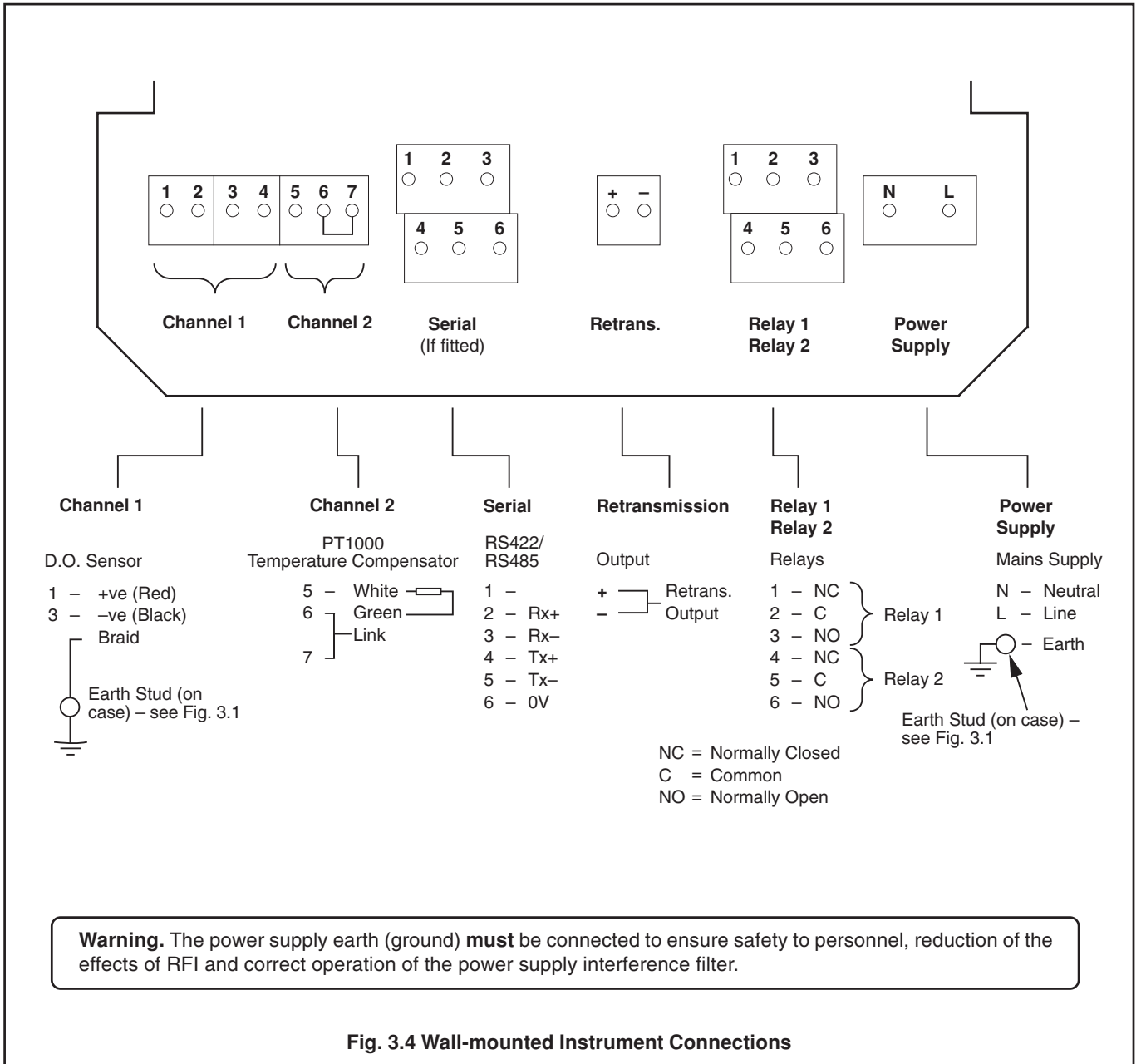

Fig. 3.4 Wall-mounted Instrument Connections

...3 ELECTRICAL CONNECTIONS

3.4 Panel-mounted Instrument Connections – Fig. 3.5

Note. Refer to Fig. 3.2 for Access to Terminals.

Caution. Slacken terminal screws fully before making connections.

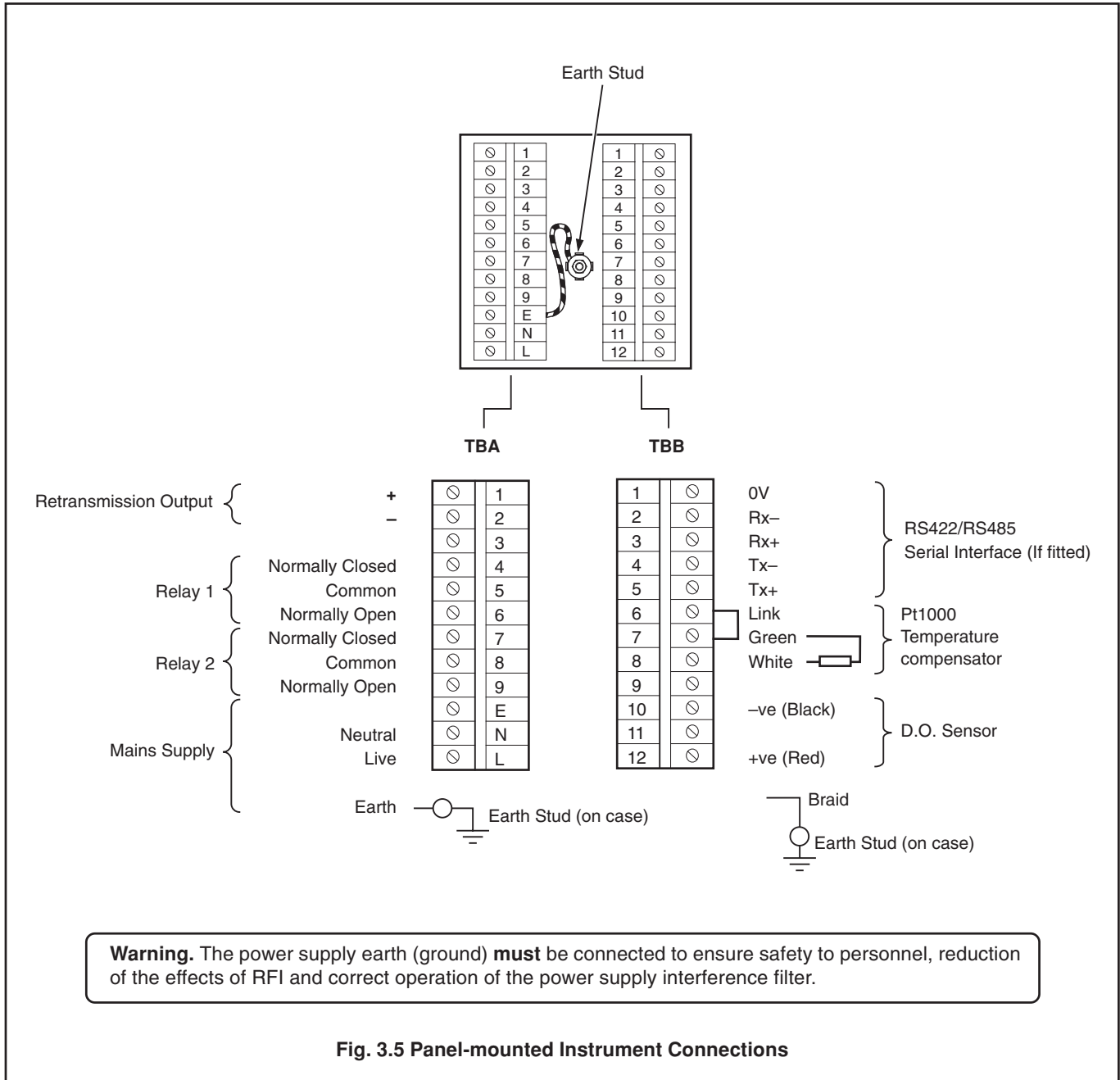
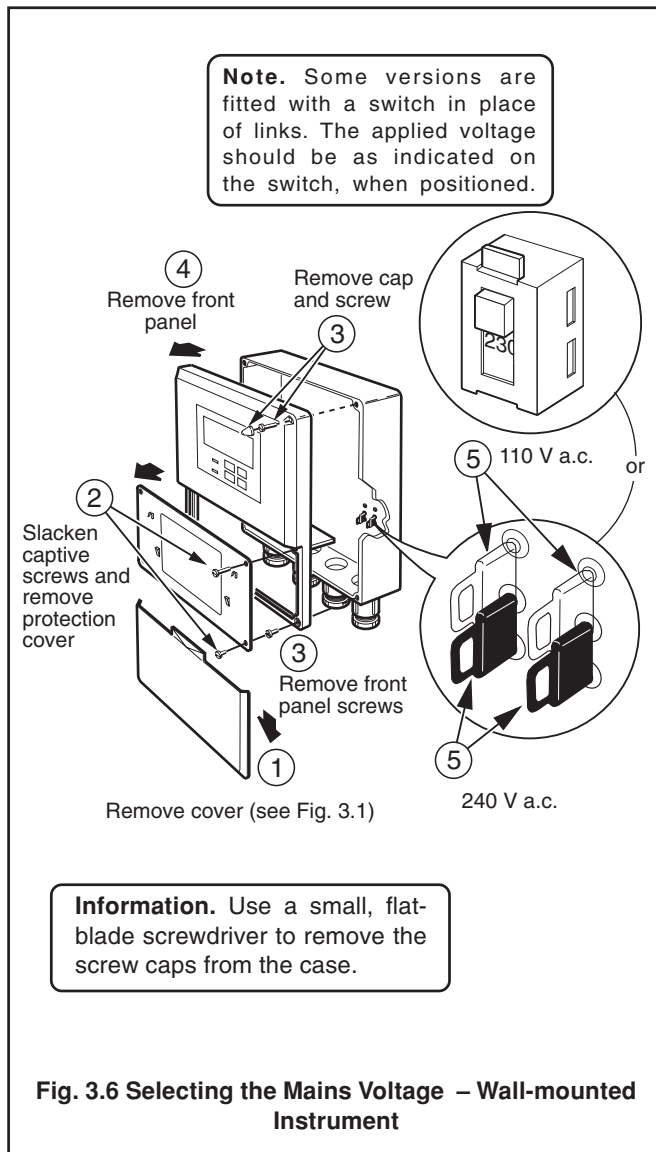

Fig. 3.5 Panel-mounted Instrument Connections

3.5 Selecting the Mains Voltage

3.5.1 Wall-mounted Instrument



3.5.2 Panel-mounted Instrument

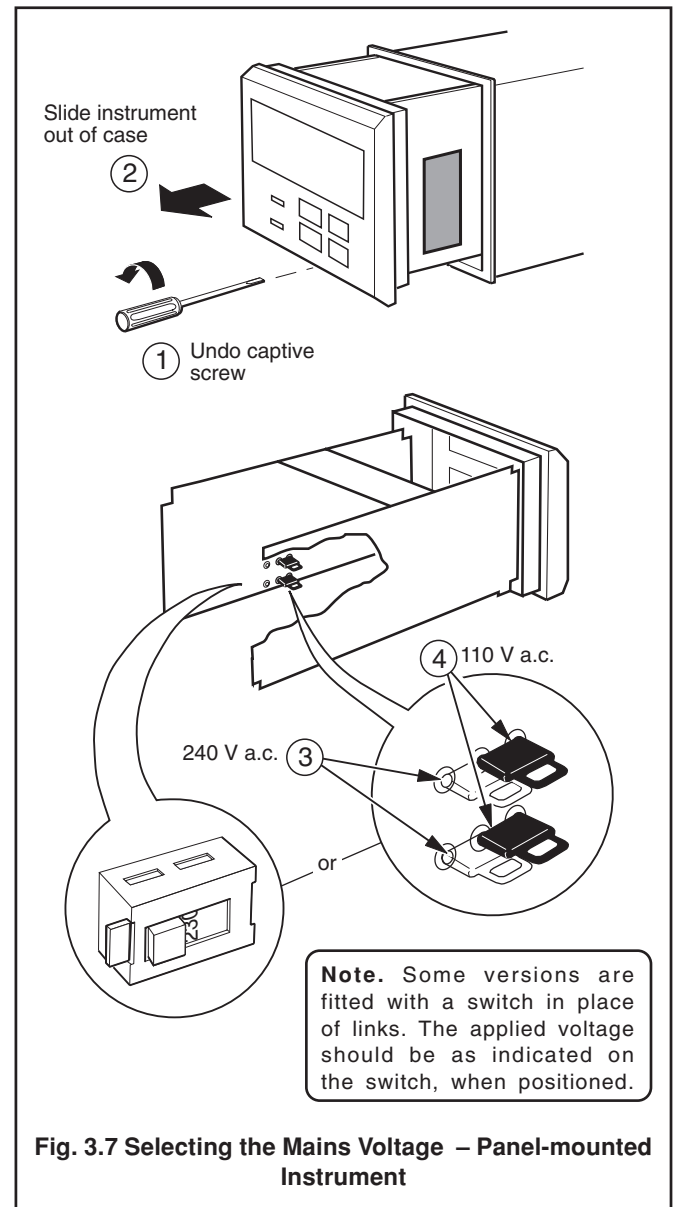

4 SETTING UP

4.1 Fitting the Dissolved Oxygen Sensor – Fig. 4.1

Caution.

- Only install the oxygen sensor immediately prior to use, otherwise leave it stored in its protective container.
- Take special care to line up the two pins in the oxygen sensor with their respective sockets before making the connection and tightening.
- Take care not to damage the delicate membrane on the end of the oxygen sensor.
- Ensure that the mating surfaces (carrying the electrical connection) of the oxygen sensor and connector body are clean and **completely** dry.

- ① Remove the top from the oxygen sensor container.
- ② Unscrew the protective cap from the rear of the oxygen sensor.
- ③ Fit (or replace, if fitting a new sensor) the smaller of the 2 O-rings. Locate the sensor on the connector body and tighten up the connector nut onto the sensor.

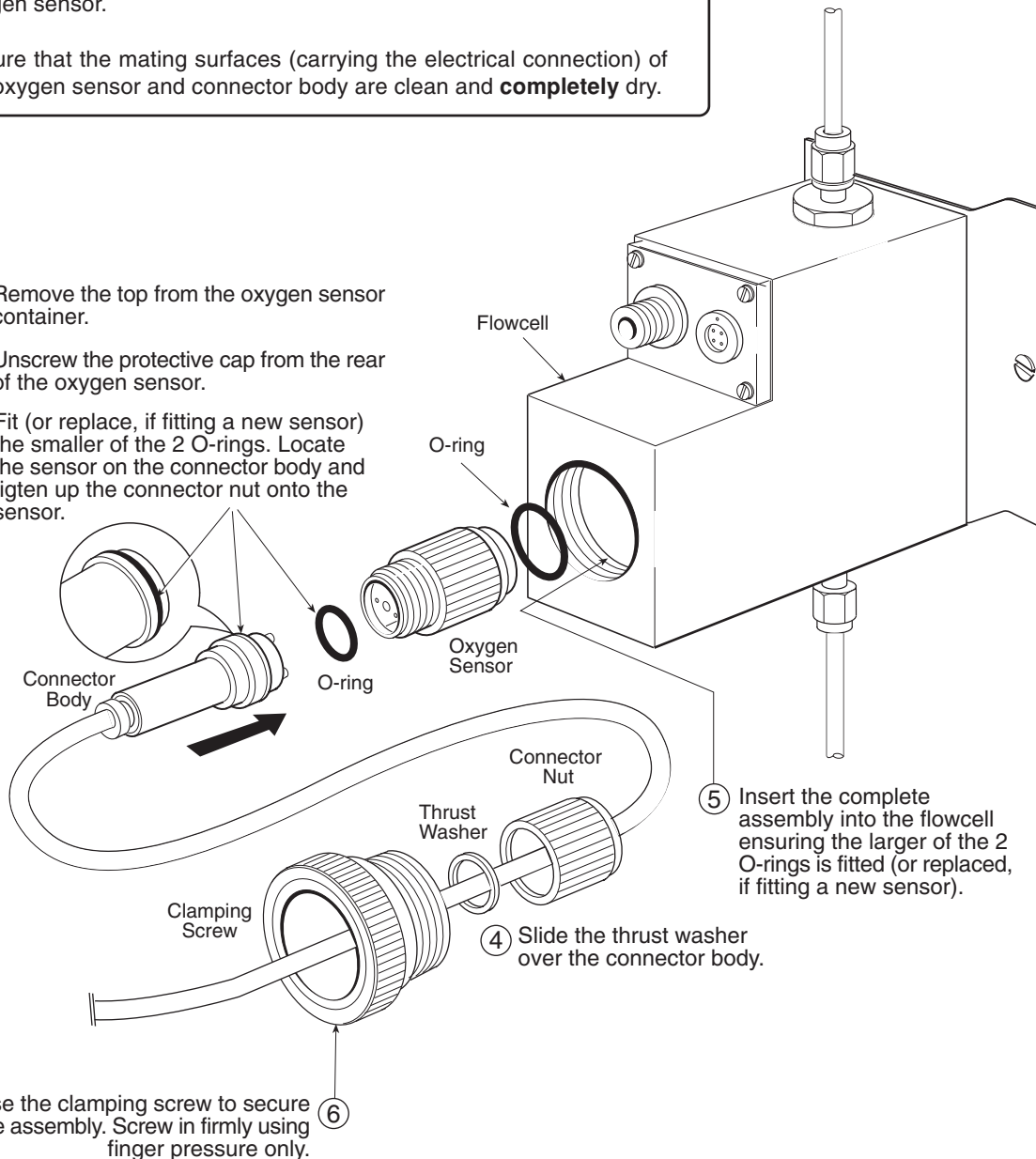

Caution. Do not overtighten the clamping screw.

Fig. 4.1 Fitting the Dissolved Oxygen Sensor

4.2 Connecting the Flowcell – Fig. 4.2

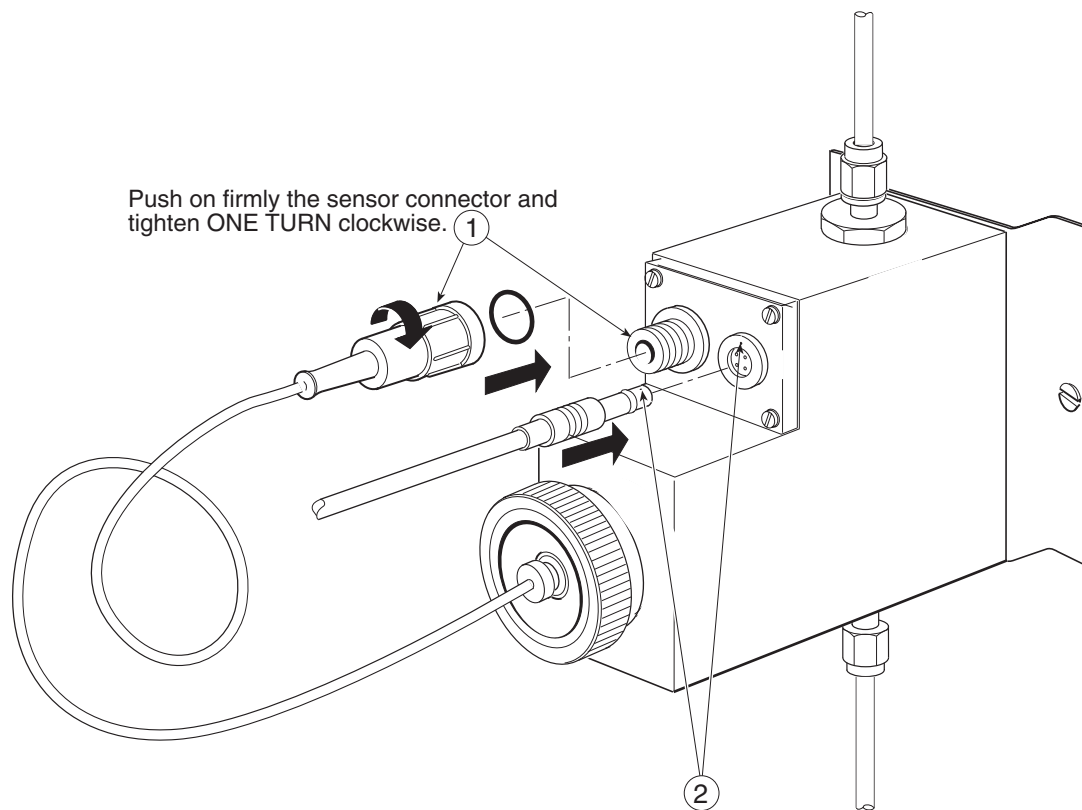

Line up the red spots and push on firmly the plug until the locking ring engages.

Note.

- The plug is a latching type to prevent it's accidental removal. To remove, pull out holding the plug at its widest point.
- The plug is protected against spillage and corrosion by a sleeve which slides over it

Fig. 4.2 Electrical Connections at the Flowcell

5 CONTROLS AND DISPLAYS

5.1 Displays – Fig. 5.1

The display comprises a 5-digit, 7-segment digital upper display line and a 16-character dot-matrix lower display line. The upper display line shows numerical values of dissolved oxygen concentration, temperature, alarm set points or programmable parameters. The lower display line shows the associated units or programming information.

5.2 Switch Familiarization

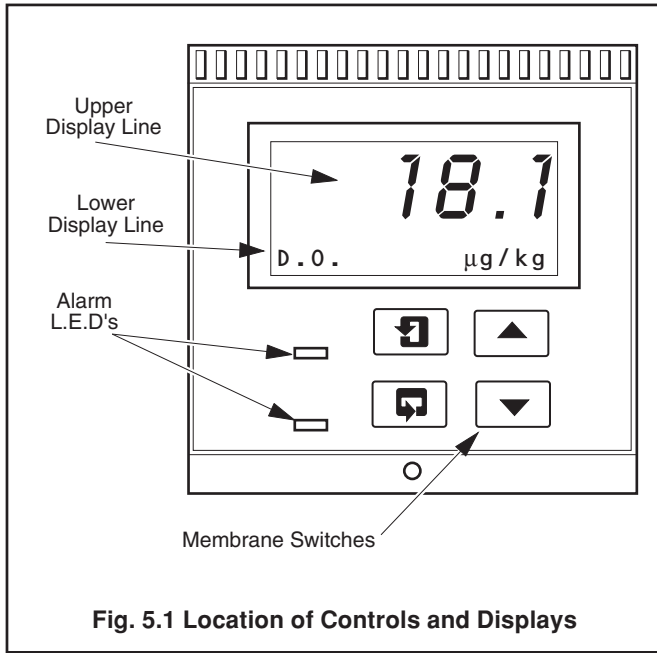

Fig. 5.1 Location of Controls and Displays

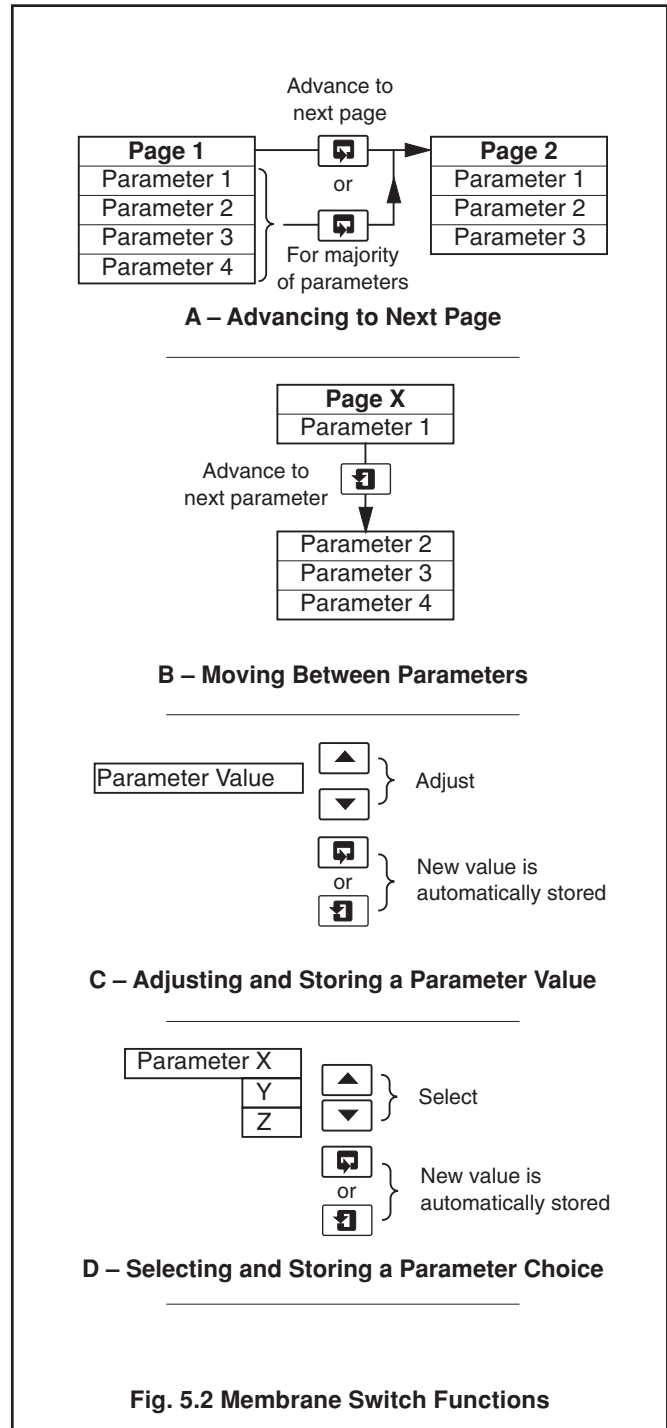
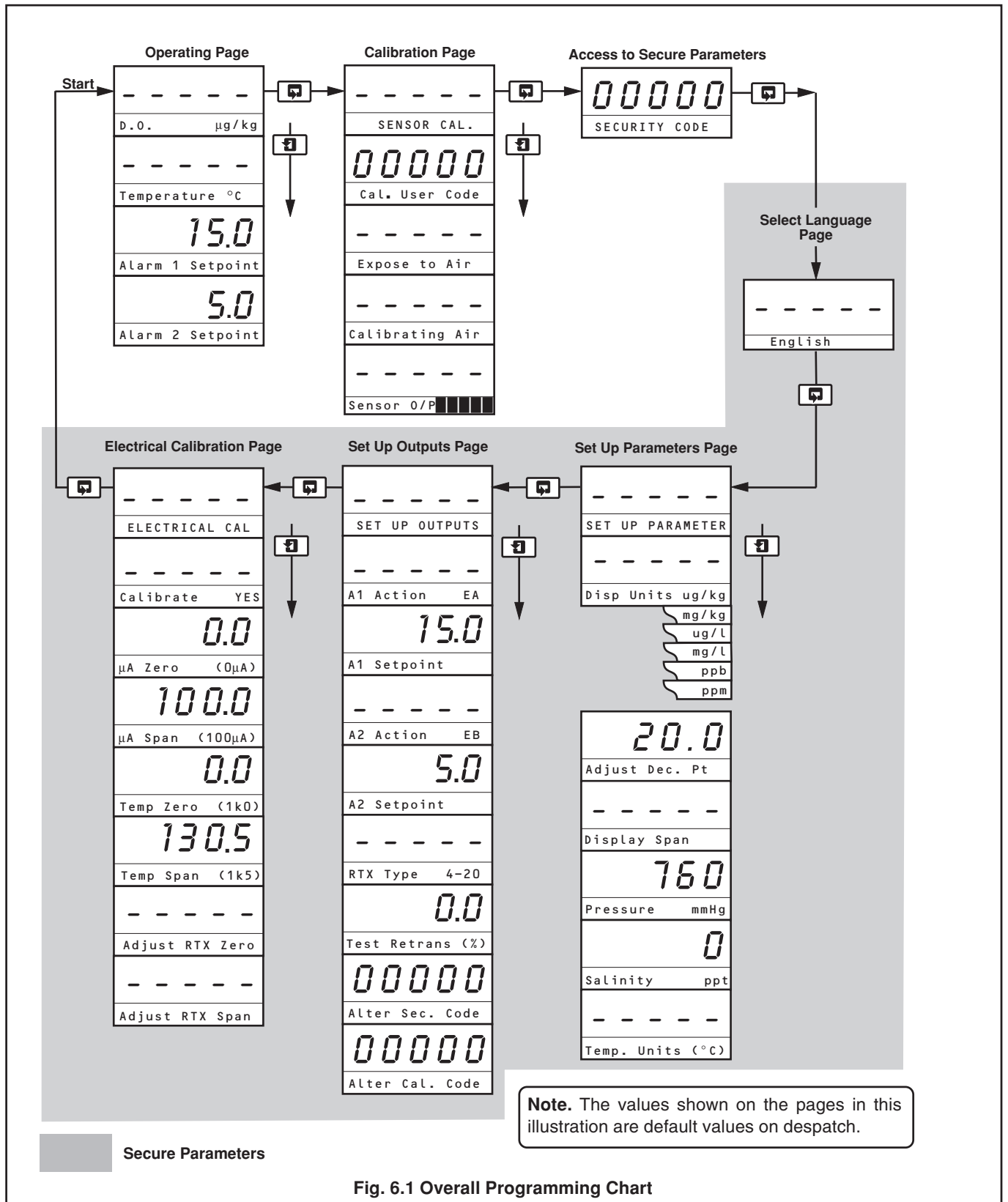

Fig. 5.2 Membrane Switch Functions

6.1 Instrument Start-up – Fig. 6.1

Ensure all electrical connections have been made and switch on the power supply. If the instrument is being commissioned for the first time, calibration and programming of parameters is required.

The overall operating and programming chart is shown in Fig. 6.1.



...6 START UP AND OPERATION

6.2 Operation – Dissolved Oxygen Measurement Mode

Operation in the Dissolved Oxygen measurement mode comprises an **Operating Page** and a **Calibration Page**. The **Operating Page** is a general use page in which parameters are viewed only and cannot be altered. To alter or program a parameter, refer to the programming pages in Section 7. The **Calibration Page** allows a calibration to be carried out. A 5-digit calibration code is used to prevent unauthorized access to the sensor calibration page. The value is preset at 00000 to allow access during commissioning, but should be altered to a unique value, known only to authorized operators, in the **Set Up Outputs page** – see Section 7.4

6.2.1 Operation Page

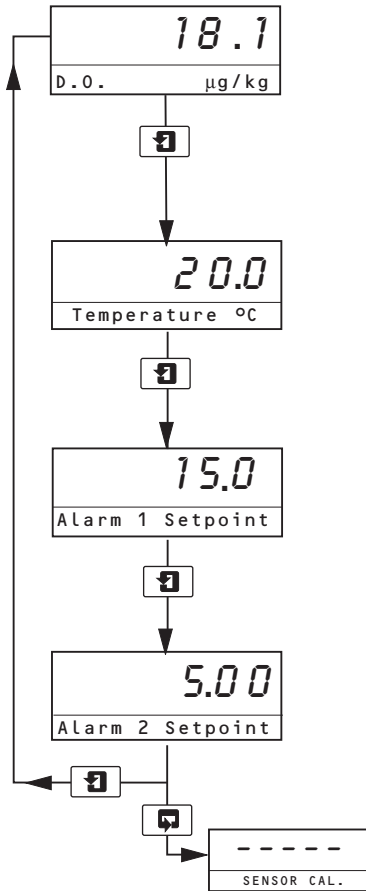

Measured Dissolved Oxygen

The measured dissolved oxygen is displayed in either mg/kg or μg/kg.

 – press to advance to next parameter

or

 – press to advance to **Calibration Page**, Section 6.2.2.

Sample Temperature

The sample temperature is displayed in either °C or °F – see Section 7.3

Alarm 1 Set Point

The set point value and relay/l.e.d. action are programmable – see Section 7.4, **Set Up Outputs Page**.

Alarm 2 Set Point

The set point value and relay/l.e.d. action are programmable – see Section 7.4, **Set Up Outputs Page**.

Advance to **Calibration Page** – see Section 6.2.2.

6.2.2 Calibration Page

Calibration involves standardizing the instrument and the sensor by exposing the sensor to air. During a calibration, retransmission and alarm outputs are automatically held to prevent inadvertent operation of ancillary equipment.

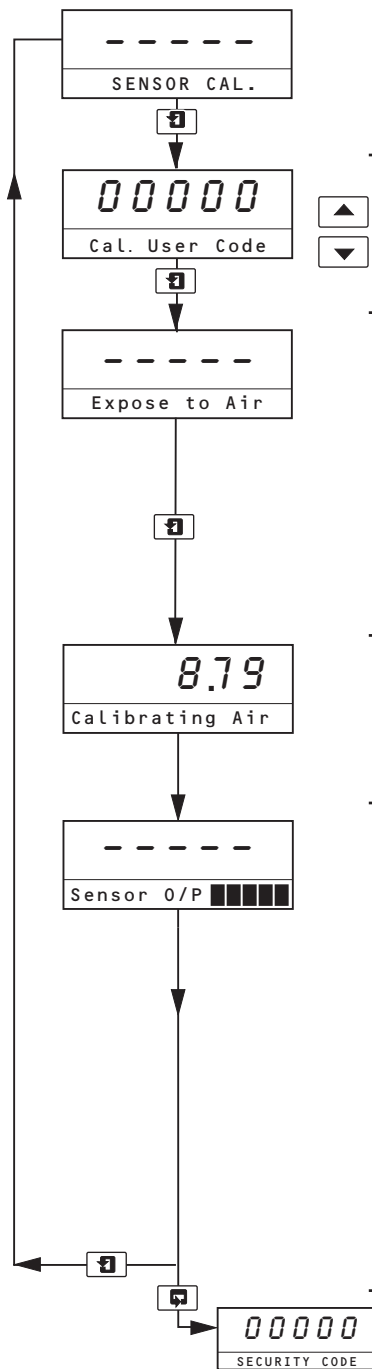

– press to advance to next parameter

or

– press to Advance to **Access to Secure Parameters Page**, Section 7.1

Calibration Access

Enter the required calibration code number, between 00000 and 19999. If an incorrect value is entered, access to calibration is prevented and **Calibration Page** is displayed.

Expose the sensor to air, **before depressing the button**, using the following procedure:

- 1) shut off the sample flow – see Fig. 2.7A,
- 2) remove the sensor from the flowcell – see Section 4.1),
- 3) carefully dry the sensor with a soft tissue, and
- 4) expose the sensor to air;

or

by using suitably installed valves (see Fig. 2.7B) isolate the flowcell and drain out the water; first open valve V2, then close valve V1.

Calibrating Air

Displayed for three to five minutes, allowing the sensor response to become stable. During this period the oxygen value displayed is calculated using the data from the previous calibration. If the sensor output is satisfactorily large and stable then **Calibration Pass** is displayed and the new, corrected oxygen concentration is displayed on return to the **Operating Page**.

Sensor Output

Provides an indication of the sensor performance in the form of a 5 bar display. When 5 bars are displayed, the sensor has maximum life remaining.

When 2 bars are displayed and flashing, the sensor is exhausted.

A replacement sensor should be ordered when three bars are displayed.

If a calibration is carried out and 2 flashing bars are displayed, the calibration is ignored and the values obtained from the previous calibration are used.

Return the system to normal by either a):

- 1) Dry the interior of the flowcell with an absorbent tissue, and replace the oxygen sensor – see Section 4.1.

- 2) Start the sample water flow – see Fig. 2.7.

or b):

Start the sample water flow by opening valve V1, then closing valve V2 – see Fig. 2.7B

Advance to **Access to Secure Parameters Page**, Section 7.1

Caution. Take care that the membrane at the end of the sensor does not come into contact with any hard or sharp objects.

Note.

- The air should be saturated with water vapour. This can be conveniently achieved by suspending the sensor inside a bottle containing a few drops of water.
- Errors in the calibration procedure, e.g. water droplets on the sensor membrane, can cause Calibration Fail to be displayed.

7 PROGRAMMING AND ELECTRICAL CALIBRATION

7.1 Access to Secure Parameters

A 5-digit security code is used to gain access to the secure parameters.

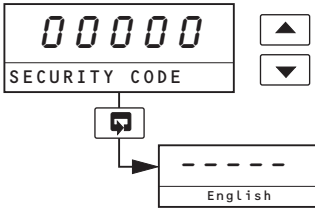

Security Code

Enter the required code number, between 00000 and 19999, to gain access to the secure parameters. If an incorrect value is entered, access to subsequent programming pages is prevented and **Operating Page** is displayed.

Advance to **Select Language Page**, Section 7.2.

7.2 Select Language Page

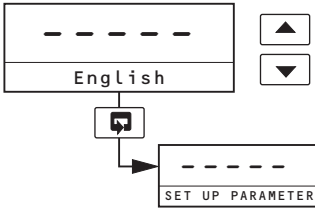

Use the buttons to select the required language (English, French, German or Spanish).

Advance to **Set Up Parameters Page**, Section 7.3.

7.3 Set Up Parameters Page

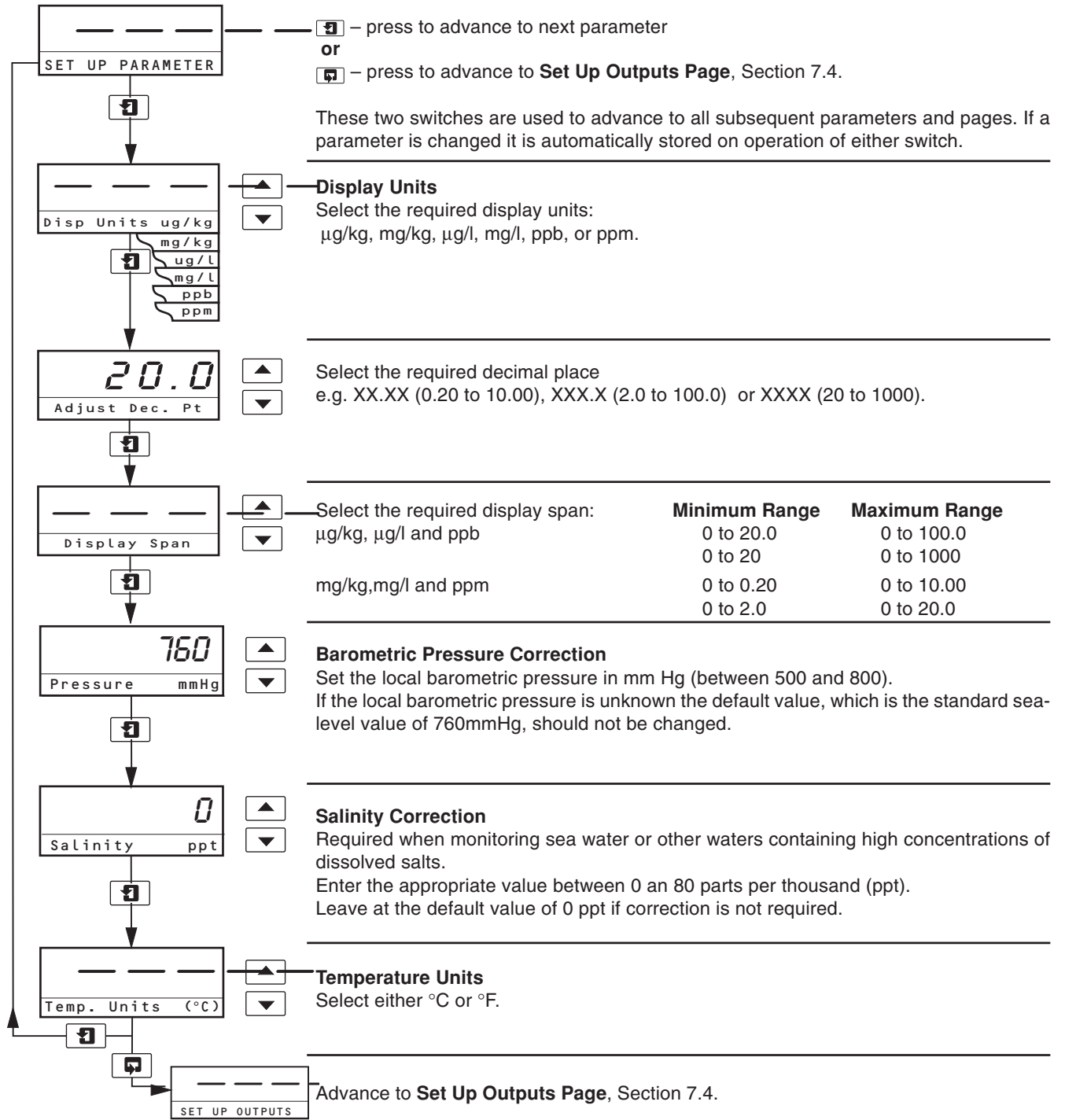

7.4 Set Up Outputs Page

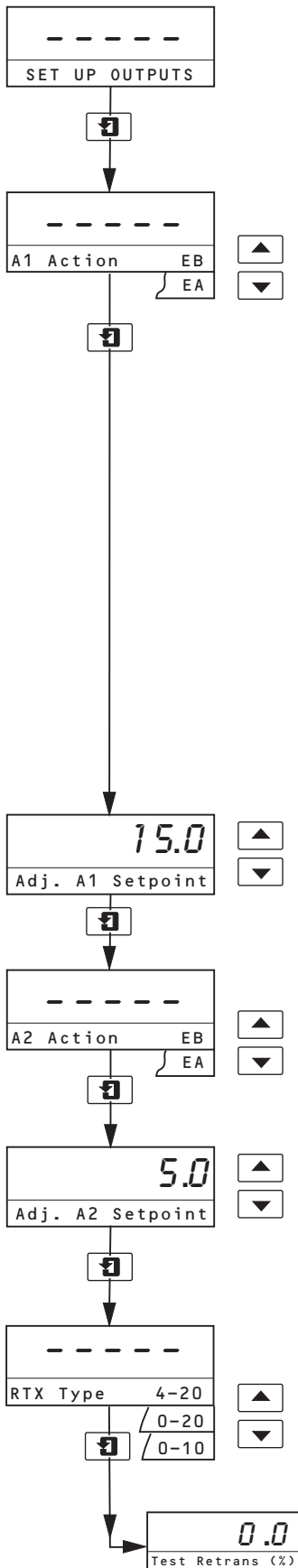

- press to advance to next parameter
or
- press to advance to **Electrical Calibration Page**, Section 7.7.

These two switches are used to advance to all subsequent parameters and pages. If a parameter is changed it is automatically stored on operation of either switch.

Alarm 1 Action

For **'Fail-safe'** alarm operation the relay's alarm state must be the same as the power-down state, i.e. the relay is de-energised.

For **high alarm** operation the relay must be **Energised Below** the alarm set point (EB). For **low alarm** operation the relay must be **Energised Above** the alarm set point (EA).

The alarm l.e.d.s are illuminated in the alarm condition.

Select the required alarm 1 action from the following table:

Alarm Action	L.E.D. Action for Input Above Set Point	L.E.D. Action for Input Below Set Point	Relay Action for Input Above Set Point	Relay Action for Input Below Set Point
EB	ON	OFF	De-energised	Energised
EA	OFF	ON	Energised	De-energised

The set point band is defined as the actual value of the set point plus or minus the hysteresis value. The hysteresis value is $\pm 1\%$ of the full span value displayed in the **Set Up Parameter Page** – see Section 7.3. Alarm action occurs if the input value is above or below the set point band. If the input moves within the set point band the last alarm action is maintained.

Alarm 1 Set Point

The alarm 1 set point can be set to any value within the input range being displayed. The set point value is subject to hysteresis as detailed above.

Set the alarm set point to the required value.

Alarm 2 Action

Repeat as for **Alarm 1 Action** above.

Alarm 2 Set Point

Repeat as for **Alarm 1 Set Point** above

Retransmission Output Assignment

Select current output (mA).

Continued on next page.

...7.4 Set Up Outputs Page

Continued from previous page.

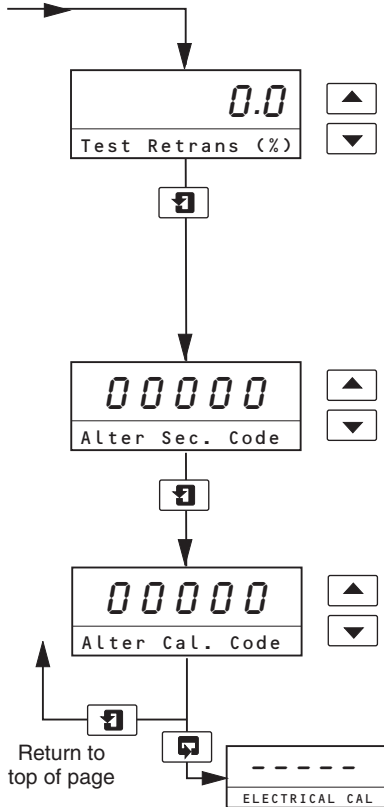

Test Retransmission Output

The instrument automatically transmits a test signal of 0, 25, 50, 75 or 100% of the retransmission range selected above. The % test signal selected is shown on the upper display.

Example – for a selected range of 0 to 20 mA and 50% retransmission test signal, 10 mA is transmitted.

Select the required retransmission test signal.

Alter Security Code

Set the security code to a value between 00000 and 19999.

IMPORTANT – YOU MUST MEMORIZE THE NEWLY SET SECURITY CODE. If it is forgotten contact the Company for advice.

Alter D.O. Calibration Code

Set the security code to a value between 00000 and 19999.

IMPORTANT – YOU MUST MEMORIZE THE NEWLY SET SECURITY CODE. If it is forgotten contact the Company for advice.

Advance to **Electrical Calibration Page**, Section 7.7.

...7 PROGRAMMING AND ELECTRICAL CALIBRATION

7.5 Electrical Calibration

Note. The instrument is calibrated by the company prior to despatch and an electrical calibration should only be carried out if the accuracy of the instrument is suspect.

7.5.1 Equipment Required

- a) Current source: 0 to +100 μ A.
- b) Decade resistance box (temperature input simulator): 0 to 1k5 Ω .
- c) Digital milliammeter (current output measurement): 0 to 20 mA.

Note. Resistance boxes have an inherent residual resistance which may range from a few milliohms up to 1 ohm. This value must be taken into account when simulating input levels, as should the overall tolerance of the resistors within the boxes.

7.6 Preparation

- a) Switch off the supply and disconnect the sensor, temperature compensator and current output from the electronics unit terminal block – see Fig. 3.4 or Fig. 3.5.
 - b) Wall Mounted Instruments
 - 1) Connect the microamp source '+' and '-' to terminals 1 and 3 respectively.
 - 2) Connect the decade box between terminals 5 and 6, with terminals 6 and 7 linked.
 - 3) Connect the milliammeter to the retransmission output terminals.
 - 4) Ensure that the earth of the current source and decade box are connected to the instrument earth stud.
- Panel Mounted Instruments
- 1) Connect the microamp source '+' and '-' to terminals 12 and 10 respectively.
 - 2) Connect the decade box between terminals 7 and 8, with terminals 6 and 7 linked.
 - 3) Connect the milliammeter to the retransmission output terminals.
 - 4) Ensure that the earth of the current source and decade box are connected to the instrument earth stud.
- c) After either of the sections in b) above, switch on the supply and allow ten minutes for the circuits to stabilize.
 - d) Select the **Electrical Calibration Page** and proceed as in Section 7.7, following.

7.7 Electrical Calibration Page

In this section the actual values denoted by 'xxxxx' are unimportant and are used to determine display reading stability when carrying out the electrical calibration procedure.

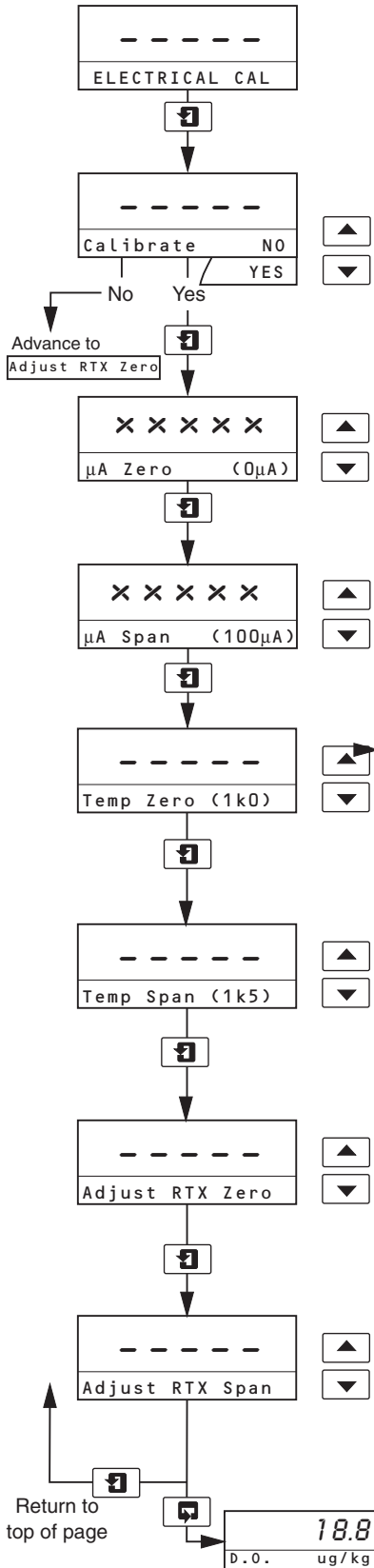

– press to advance to next parameter
or
 – press to advance to **Operating Page**, Section 6.2.1.

Electrical Calibration

Select YES to access the electrical calibration sequence. Select NO to advance to **Adjust Retransmission Zero** – see following page.

Microamp Zero

Set the current source to 0 µA and allow the instrument display to stabilize.

Microamp Span

Set the current source to +100 µA and allow the instrument display to stabilize.

Calibrate Temperature Zero

Set the temperature simulator resistance box to 1000Ω and allow the instrument display to stabilize.

Calibrate Temperature Span

Set the temperature simulator resistance box to 1500Ω and allow the instrument display to stabilize.

Adjust Retransmission Zero

Set the millimeter reading to 4.00mA.

Note. Retransmission signal span is calibrated using 20.00 mA. The correct value transmitted depends on the range selected in the **Set Up Outputs Page**.

Adjust Retransmission Span

Set the millimeter reading to 20.00mA.

Note. Retransmission signal span is calibrated using 20.00 mA. The correct value transmitted depends on the range selected in the **Set Up Outputs Page**.

Return to **Operating Page**, Section 6.2.1.

8 SIMPLE FAULT FINDING

8.1 Maintenance

No routine maintenance is required for this instrument other than periodic calibration – see Section 6.2.2. However, if following a calibration the sensor output shows two flashing bars, the sensor capsule has therefore become exhausted and needs replacing immediately.

If the output shows three bars, replace the sensor capsule in the near future.

Storage

DO:

- use sensors in date rotation to prevent them being stored longer than necessary.
- at all times, store sensors in a dry and cool environment.
- store sensors in a refrigerator to extend their life, but DO NOT allow them to freeze.

DO NOT:

- allow sensors to dry out, either in storage or in use.
- leave sensors in vehicles where they are likely to freeze or be exposed to high temperatures.
- leave sensors on-site without protection from direct sun or high temperatures.
- use the sensor if it's sealed environment has dried out.

A dirty membrane may also be the cause of the low sensor output. To clean the sensor proceed with the following.

8.1.1 Cleaning/Changing the Sensor

Caution.

- Only install the oxygen sensor immediately prior to use, otherwise leave it stored in its protective container.
- Take special care to line up the two pins in the oxygen sensor with their respective sockets before making the connection and tightening.
- Take care not to damage the delicate membrane on the end of the oxygen sensor.
- Ensure that the mating surfaces (carrying the electrical connection) of the oxygen sensor and connector body are clean and **completely** dry.

- 1) Isolate and drain the flowcell.
- 2) Unscrew the clamping screw and remove the sensor assembly from the flowcell.
- 3) Inspect the sensor. If the membrane is clean, replace the sensor – proceed to 4) below.

If deposits are visible on the membrane, remove them by gently wiping the membrane with a moist paper tissue; for oily or greasy deposits, the tissue may be moistened with a mild detergent or, if necessary, with iso-propyl alcohol (propan - 2 - ol). After cleaning, dry the interior of the flowcell with a paper tissue or soft cloth, ensure that the O-ring is correctly positioned against the shoulder near the end of the cavity – proceed to 11) below to test the sensor.

- 4) Unscrew the connector nut; remove the sensor capsule and discard both capsule and sealing washer.
- 5) Take out the O-ring from the flowcell; dry the interior of the flowcell with a tissue or soft cloth and insert the new O-ring supplied with the replacement capsule. Ensure that the O-ring is correctly located on the shoulder near the end of the cavity.
- 6) Remove the top from the container of the new sensor.
- 7) Unscrew the protective cap from the rear of the sensor
- 8) Place a new sealing washer (supplied) as shown in Fig. 4.1 and locate the connector body on the sensor.
- 9) Slip the connector nut over the connector body and screw onto the sensor firmly.
- 10) Slide the thrust washer over the connector body.
- 11) Insert the complete assembly into the flowcell.
- 12) Use the clamping screw to secure the assembly. Screw in firmly using finger pressure only.

Caution. Do not overtighten the clamping screw.

- 13) Reinststate sample flow through the flowcell.
- 14) Carry out a calibration – see Section 6.2.2.

8.2 Error Messages

If erroneous or unexpected results are obtained the fault may be indicated by an error message – see Table 8.1.

Table 8.1 Error Messages

Error Message	Possible Cause
FAULTY PT1000	Temperature compensator/ associated connections are either open/short circuit.
FAULTY MODULE	D.O. sensor input module is probably faulty.
LAST CAL. FAILED	Message only displayed on power-up. The last D.O. calibration, carried out before power-down, failed.*
NV MEMORY ERROR	The contents of the non-volatile memory have not been read correctly during power up.**

* This message applies the last D.O. calibration carried out prior to power-down and is **not** an indication of incorrect **electrical calibration**.

** To rectify the fault, switch off, wait 10 seconds and switch on again. If the fault persists contact the Company.

8.3 Low Sensor Output or no Response to D.O. Changes

Replace the sensor (see Section 8.1.1) as an initial check. It is also important that all program parameters have been set correctly and have not been altered inadvertently – see Section 7.

If the fault persists:

- a) Carry out an electrical calibration as detailed in Section 7 and check that the instrument responds correctly to the current input.

Failure to respond to the input usually indicates a fault with the transmitter, which must be returned to the Company for repair.

- b) If the response in a) is correct, select the **Operating Page** and set the current source to a value which gives an on-scale D.O. reading on the transmitter. Make a note of the current source setting and the D.O. reading. Reconnect the sensor cable and connect the current source to the sensor end of the cable. Set the same current value on the source and check that the transmitter displays the noted reading in this configuration.

If check a) is correct but check b) fails, check the cable connections and condition. If the response for both checks is correct, fit a new sensor and calibrate it.

9 SPECIFICATION

Specification — Flowcell

Mounting

Vertically, using the built-in fixing bracket

Measuring ranges

Programmable within the ranges 0 to 20.0µg/kg
and 0 to 20mg/kg

Scaling

µg/kg, mg/kg or ppb, ppm

Accuracy

±5% of reading or ±1µg/kg, whichever is the greater

Response time

90% of a step change in 1 minute

Resolution

0.1 µg/kg

Stability

±5% of reading or ±1µg/kg per week, whichever is the greater

Temperature compensation

5 to 55°C automatic using Pt1000 resistance thermometer

Salinity correction

Preset within the range 0 to 80ppt

Barometric pressure correction

Preset within the range 500 to 800mm Hg

Sample flow

100 to 500ml/min

Sample pressure

Maximum 2bar

Sample temperature

5 to 55°C (41 to 131°F)

Sensor ambient temperature

0 to 55°C (32 to 131°F)

Specification — Transmitter

Transmitter Display

Measured value

5-digit x 7-segment back-lit LCD

Information

16-character, single line, dot matrix, back-lit LCD

Insulation, contacts to earth

2kV RMS

Set Points and Relays

No. of set points

Two

Set point adjustment

Programmable

Set point hysteresis

±1% of FSD (fixed)

Local set point annunciation

Red LED

No. of relays

Two

Relay contacts

Single pole changeover

Rating:	250V AC	250V DC maximum
	3A AC	3A DC maximum

Loading:	750VA (non-inductive)	30W maximum
	75VA (inductive)	3W maximum

Retransmission

No. of retransmission signals

One, fully isolated
Optional second current output

Output current

0 to 10, 0 to 20 or 4 to 20mA programmable

Maximum load resistance

500Ω (20 mA maximum)

Serial communication

RS422/RS485 (optional, with one current output signal)

Power Supply

Voltage requirements

100 to 130V or
200 to 260V 50/60 Hz

Power Consumption

< 10VA

Error due to power supply variations

Less than ±2% for +6% -20% variation from nominal supply voltage

Insulation, mains to earth

2kV RMS

...Specification — Transmitter**Environmental Data****Operating temperature limits**

-20 to 55°C (-4 to 131°F)

Operating humidity limits

Up to 95% RH non-condensing

Storage temperature limits

Flowcell -25 to 70°C (-13 to 158°F)

Sensor 0 to 55°C (32 to 131°F)

Transmitter -25 to 70°C (-13 to 158°F)

Protection**Flowcell**

IP65

Transmitter

Panel-mounting	IP66/NEMA4X
Wall-mounting	IP66/NEMA4X front

Mechanical Data**Mounting**

Wall-mounting or Panel-mounting

Overall dimensions

Flowcell (without unions)	97 x 80 x 108.6mm (3.82 x 3.15 x 4.28 in.)
Transmitter Wall-mounting	160 x 214 x 68mm (6.29 x 8.43 x 2.68 in.)
Panel-mounting	96 x 96 x 191mm (3.78 x 3.78 x 7.52 in.)
Panel cut-out	92 x 92mm (3.62 x 3.62 in.)

Weights

Flowcell (with sensor fitted)	0.75kg (1.65 lb)
Transmitter Wall-mounting	2kg (4.41 lb)
Panel-mounting	1.5kg (3.31 lb)

Sample connections

Compression fitting to accept
either 6mm OD tubing
or 1/4 in. OD tubing

SS/9437 Issue 5

10 SPARES

Note. Ensure that the correct O-rings are fitted in the appropriate positions as shown.
Fit new O-rings when a new sensor is fitted.

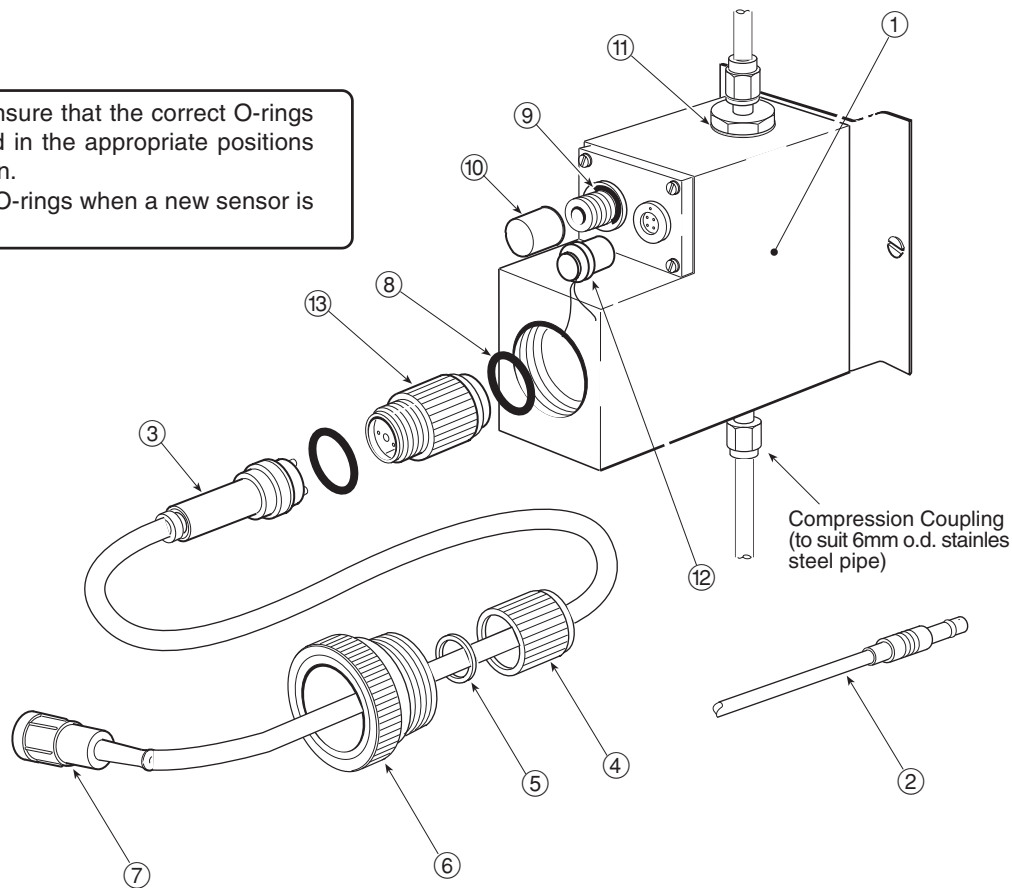

Item	Description	Part No.
1	Flowcell	
2	Sensor Connector Cable Assembly of one of the following lengths: 3 metres 5 metres 10 metres 20 metres 30 metres	9437030 9437031 9437032 9437033 9437034
3	Handle Assembly which includes items 3 to 7	9437025
4	Connector Nut	9435450
5	Thrust Washer	9435462
6	Clamping Screw	9435468
7	Plug	
8	Replacement Seals Pack comprising: 2 off O-ring (7/8in I.D. x 0.070in cord)	9437016 0211193
9	O-ring	0211062
10	2 off End Cap *	0211818
11	2 off Nylon Seal for 3/8in BSP Coupling	0216523
12	Protective Cover	0238304
13	Oxygen Sensor (including O-rings)	9435300

* The end cap is used to blank off the electrical connector when the plug is not fitted.

Fig. 10.1 Part Numbers

PRODUCTS & CUSTOMER SUPPORT

Products

Automation Systems

- *for the following industries:*
 - Chemical & Pharmaceutical
 - Food & Beverage
 - Manufacturing
 - Metals and Minerals
 - Oil, Gas & Petrochemical
 - Pulp and Paper

Drives and Motors

- *AC and DC Drives, AC and DC Machines, AC motors to 1kV*
- *Drive systems*
- *Force Measurement*
- *Servo Drives*

Controllers & Recorders

- *Single and Multi-loop Controllers*
- *Circular Chart and Strip Chart Recorders*
- *Paperless Recorders*
- *Process Indicators*

Flexible Automation

- *Industrial Robots and Robot Systems*

Flow Measurement

- *Electromagnetic Flowmeters*
- *Mass Flow Meters*
- *Turbine Flowmeters*
- *Flow Elements*

Marine Systems & Turbochargers

- *Electrical Systems*
- *Marine Equipment*
- *Offshore Retrofit and Refurbishment*

Process Analytics

- *Process Gas Analysis*
- *Systems Integration*

Transmitters

- *Pressure*
- *Temperature*
- *Level*
- *Interface Modules*

Valves, Actuators and Positioners

- *Control Valves*
- *Actuators*
- *Positioners*

Water, Gas & Industrial Analytics Instrumentation

- *pH, conductivity, and dissolved oxygen transmitters and sensors*
- *ammonia, nitrate, phosphate, silica, sodium, chloride, fluoride, dissolved oxygen and hydrazine analyzers.*
- *Zirconia oxygen analyzers, katharometers, hydrogen purity and purge-gas monitors, thermal conductivity.*

Customer Support

We provide a comprehensive after sales service via a Worldwide Service Organization. Contact one of the following offices for details on your nearest Service and Repair Centre.

United Kingdom

ABB Limited
Tel: +44 (0)1453 826661
Fax: +44 (0)1453 829671

United States of America

ABB Inc.
Tel: +1 775 850 4800
Fax: +1 775 850 4808

Client Warranty

Prior to installation, the equipment referred to in this manual must be stored in a clean, dry environment, in accordance with the Company's published specification.

Periodic checks must be made on the equipment's condition. In the event of a failure under warranty, the following documentation must be provided as substantiation:

1. A listing evidencing process operation and alarm logs at time of failure.
2. Copies of all storage, installation, operating and maintenance records relating to the alleged faulty unit.

ABB has Sales & Customer Support
expertise in over 100 countries worldwide

www.abb.com

The Company's policy is one of continuous product
improvement and the right is reserved to modify the
information contained herein without notice.

Printed in UK (03.10)

© ABB 2010



ABB Limited
Oldends Lane, Stonehouse
Gloucestershire
GL10 3TA
UK
Tel: +44 (0)1453 826661
Fax: +44 (0)1453 829671

ABB Inc.
Analytical Instruments
9716 S. Virginia St., Ste. E
Reno, Nevada 89521
USA
Tel: +1 775 850 4800
Fax: +1 775 850 4808