

7835 Hydrazine monitor



Advanced transmitter

- Auto-ranging with remote range indication plus two isolated analog outputs offers easy integration into plant control system
- Intuitive HMI and color display simplifies analyzer configuration during commissioning and operation

Integrated constant head unit

- Controls sample flow at optimum level during pressure fluctuations, simplifying installation and commissioning

Automatic pH buffering and temperature compensation

- Maintains accurate measurement during unstable process conditions, ensuring optimal dosing and minimizing chemical usage

Reliable sensor technology

- Repairable electrochemical sensor reduces cost of ownership by shortening routine maintenance times and reducing maintenance costs and stock holding

Sensor diagnostics

- Advanced warning of sensor depletion supports planned maintenance scheduling to increase availability and reduce unscheduled plant down-time

7835

Hydrazine monitor

Introduction

The addition of hydrazine into boiler feed water as an oxygen scavenger enables tighter control over dissolved oxygen levels, leading to reductions in corrosion. Reducing corrosion and plant breakdowns results in reduced operating costs.

Hydrazine reduces corrosion in three ways:

1. It reacts with the dissolved oxygen in water to form nitrogen and water.
2. Under high temperature and pressure, it breaks down into ammonia that increases the pH of the water, reducing the risk of corrosion.
3. It reacts with any soft hematic layers on boiler tubes and changes them to a much harder layer of magnetite.

The magnetite layer formed from the hematite helps to protect the boiler tubes from damage in the event of dissolved oxygen surges and provides some protection against dissolved salts. However, unless an excess of hydrazine over and above the amount needed to scavenge the oxygen is present, this layer reverts to hematite and the protection is then lost.

General information

The 7835 Hydrazine Monitor uses an electro-chemical cell for accurate measurement of the amount of hydrazine in boiler water. The information provided by the monitor makes it possible to avoid expensive overdosing of hydrazine and avoid the more costly damage to boiler plant due to the under-dosing of hydrazine.

The 7835 measures hydrazine over 2 ranges that are selected manually or automatically:

- 0 to 100.0 $\mu\text{g}/\text{kg}$
- 0 to 1000.0 $\mu\text{g}/\text{kg}$

The monitor comprises 2, lockable steel enclosures; 1 housing the liquid handling section and the other the electronics section. The electronics section enclosure is protected to IP55 and is separated from the liquid handling section.



Fig. 1: Main Components

Liquid handling section

The major components of the liquid handling section are:

Constant head unit

- stabilizes flow conditions during sample pressure changes

Calibration solution container

- contains a known hydrazine solution that is substituted for the sample

Solenoid valve

- actuated by the electronics section to introduce the calibration solution to the hydrazine sensor

Hydrazine sensor

- comprises a central ceramic tube fitted in a gel-filled outer jacket. A silver cathode wire is wound round the outer surface of the tube and a spiral platinum anode is inserted down the center. Sample flows up through the tube, over the platinum anode and out to waste. Electrical contact between the two electrodes is made via the ionic transport through the porous ceramic. The resultant current is proportional to the concentration of hydrazine in solution.

Buffering system

- as optimum sensor performance is achieved under high alkaline pH conditions, 7835 incorporates a reagent solution to adjust the pH of the sample. This solution is introduced into the sample via a porous disc, a method that eliminates moving parts making the pH adjustment reliable and virtually maintenance-free.

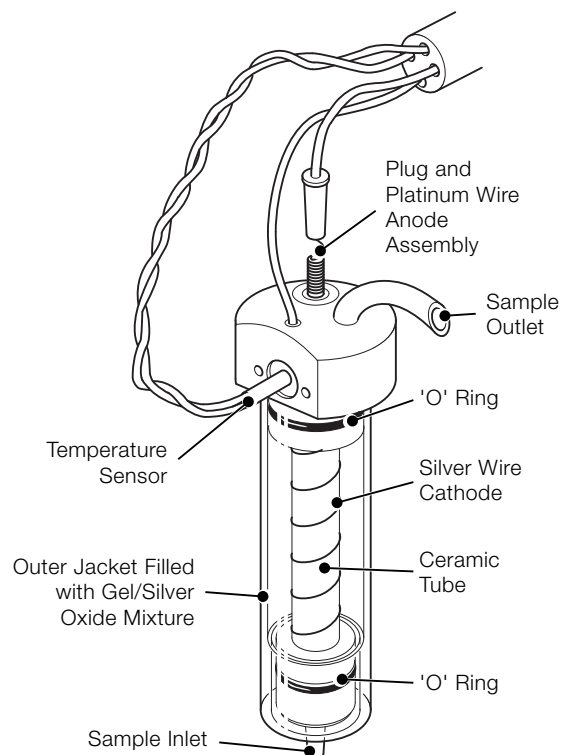

Fig. 2: Hydrazine Sensor

7835

Hydrazine monitor

Electronics section

The electronics section receives digital signals from the hydrazine sensor and converts them to a digital TFT display of hydrazine concentration. It also provides current, alarm and remote indication of range outputs as well as supplying power to the liquid handling section. The display indicates the following information:

- **Hydrazine concentration**
 - 0 to 100.0 µg/kg (low range)
 - 0 to 1000.0 µg/kg (high range)
- **Normal operation**
 - Displays hydrazine concentration
- **Calibration**
 - Displays 'Cal in Progress'
- **Sample temperature**
 - Displays sample temperature in degrees Celsius
- **Alarm settings**
 - Displays high or low alarm settings in µg/kg
- **Calibration concentration**
 - Displays the concentration of the calibration solution
- **Near calibration fail**
 - Displays 'Cal Near Fail' when the sensor is about to fail
- **Calibration fail**
 - Displays 'Cal Failed'



Fig. 3: Model 7835/700 transmitter unit

The key pad is used to:

- set the alarm values
- set the calibration solution concentration
- trigger a calibration sequence

The range can be configured to be displayed as either 0 to 100.0 µg/kg (low range) or 0 to 1000.0 µg/kg (high range) with either manual or automatic range change.

2 isolated current outputs provide remote indication of reading and 2 sets of contacts give a remote indication of range: further sets of contacts energize in the event of calibration fail and alarm conditions.

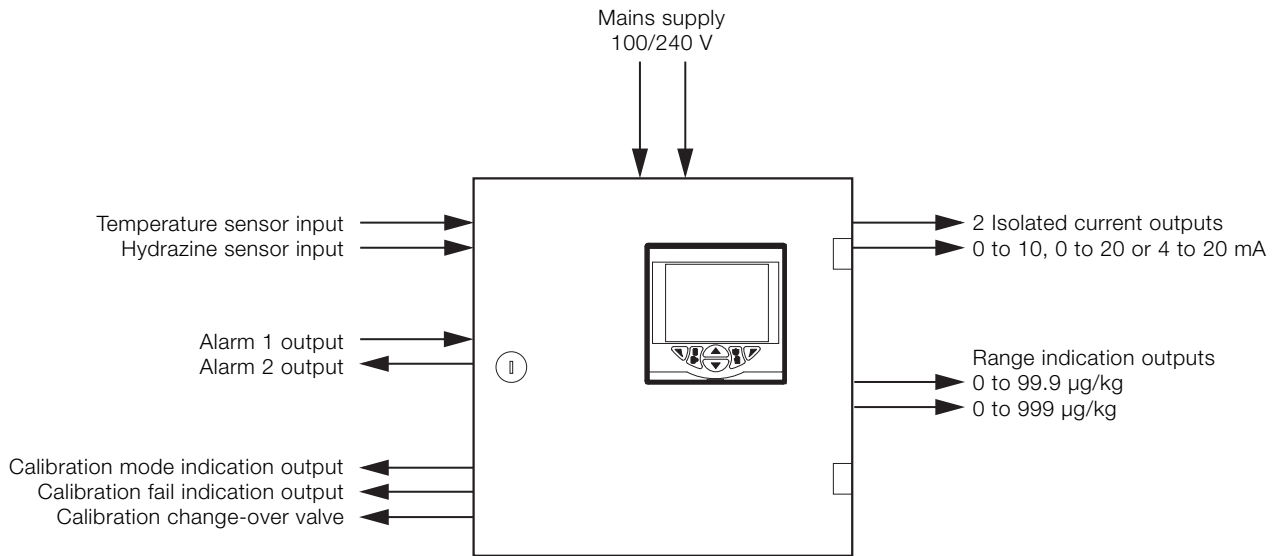

Fig. 4: Inputs and outputs

Calibration method

A reservoir located inside the liquid handling section is filled with a standard solution of known hydrazine concentration, the value of which is entered into the transmitter. No further action by the operator is required as the monitor introduces the calibration solution, carries out any adjustments and returns the monitor to the sample mode automatically.

During normal operating conditions the sample enters the constant head unit inside the monitor where the flow is stabilized. Caustic solution is added to the sample via a porous disc before it passes through the sensor cell and out to drain. During calibration the 3-way solenoid valve is activated and the sample is replaced by a standard solution of known hydrazine concentration.

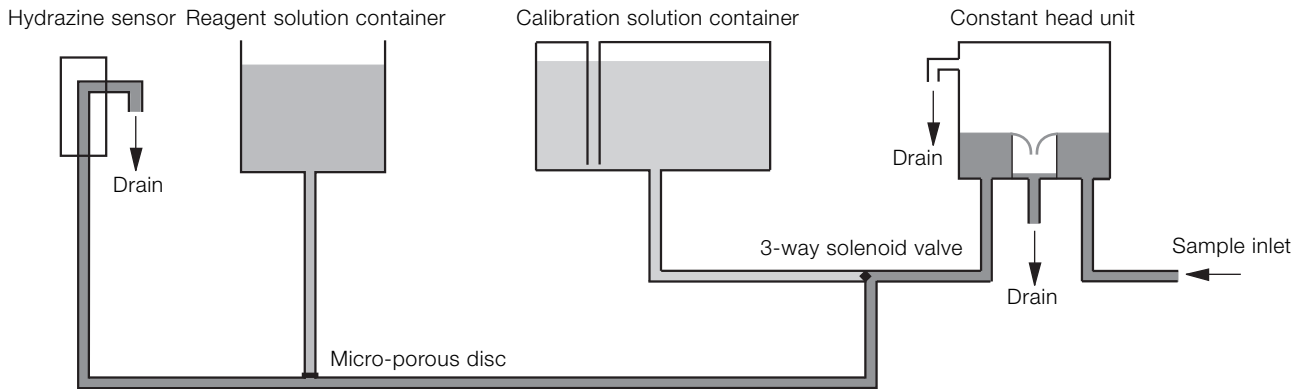

Fig. 5: Sample path during normal operating conditions

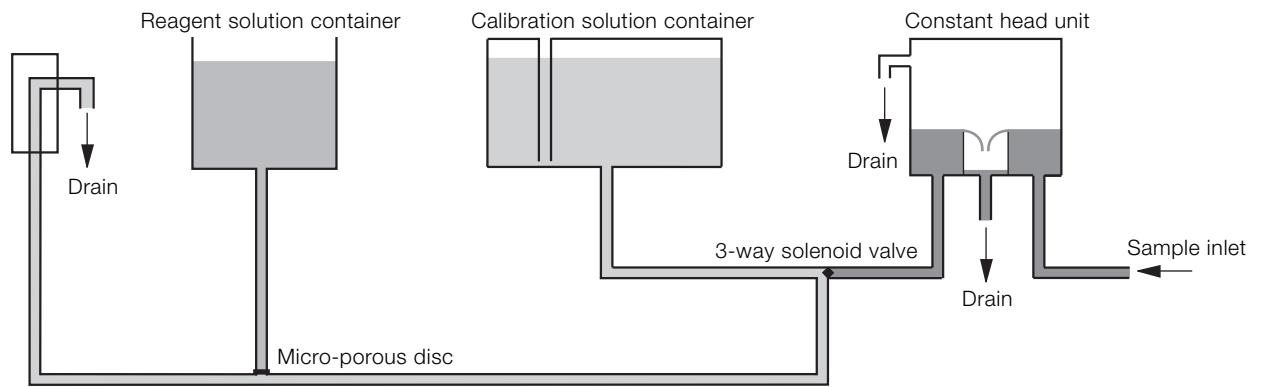

Fig. 6: Sample path during calibration mode

7835

Hydrazine monitor

Cell refurbishment

After approximately 3 months (dependent on operating conditions) the sensor current reduces to a level where the calibration fails. When this occurs the sensor must be removed, cleaned and filled with fresh gel. A gel recharge pack with applicator is available.

Maintenance

- **Calibration**
every 1 to 4 weeks (depending on operating conditions)
- **Refurbishment**
once every 3 months
- **Change reagent solution**
every 2 to 4 weeks
- **Change monitor tubing**
once a year

Reagent

5M sodium hydroxide + 5g/liter EDTA
Consumption – 250ml every 3 months.

Specification

General

Range:

- 0 to 100.0, 0 to 1000.0 $\mu\text{g kg}^{-1}$ with automatic range change

Sample temperature:

- 5 to 55 °C (41 to 131 °F)

Sample flow:

- 25 to 500 ml min^{-1} (0.8 to 17 fl oz min^{-1})

Sample pressure:

- 15 millibar (0.217 psi) minimum

Ambient temperature:

- 0 to 55 °C (32 to 131 °F)

Accuracy:

- 5 % of reading or 2 $\mu\text{g kg}^{-1}$ whichever is the greater for hydrazine concentrations up to 500 $\mu\text{g kg}^{-1}$
- Better than 10 % of reading above 500 $\mu\text{g kg}^{-1}$

Response time:

- 90 % of a step change in less than 3 minutes

Stability:

- 5 % of reading or 2 kg^{-1} per week, whichever is the greater

Outputs:

- 2 isolated current outputs in the range 0 to 10, 0 to 20 or 4 to 20 mA
- 750 Ω maximum impedance

External alarms:

- 2 normal or fail-safe, high and low concentration alarms
- Calibration Mode indication
- Calibration Fail indication
- All volt-free, 250 V, 2 A non-inductive

Calibration:

- Manual initiation of automatic calibration sequence
- Every 1 to 4 weeks depending on operating conditions

Environmental data

Transmitter and sensor

Ambient temperature:

- 0 to 55 °C (32 to 131 °F)

Storage temperature:

- -20 to 70°C (-4 to 158 °F)

Operating humidity:

- Up to 95% RH, non-condensing

Sunlight:

- Store and operate out of direct sunlight

Installation information

Mounting

Sensor and transmitter:

- 4 holes: 8.5 mm (0.33 in.) diameter
230 mm (9.05 in.) horizontal
330 mm (13.0 in.) vertical

Weight

Sensor:

- 11 kg (24 lb)

Transmitter:

- 11 kg (24 lb)

Dimensions

Sensor unit:

- 300 wide x 400 high x 200 mm deep (11.8 wide x 15.7 high x 7.9 in. deep)

Transmitter:

- 300 wide x 300 high x 200 mm deep (11.8 wide x 11.8 high x 7.9 in. deep)

Maximum distance between sensor and transmitter:

- 100 m (328 ft.)

Connections to sensor unit

Sample inlet:

- 6.3 mm (1/4 in.) OD compression fitting

Sample waste:

- 10 mm (0.39 in.) flexible – atmospheric drain

Sample line material:

- Stainless Steel

Ingress protection

Transmitter:

- IP55

7835

Hydrazine monitor

Electrical

Electrical cable

Via gland cable:

- size:
5 to 9 mm (0.2 to 0.35 in.)

Maximum core size:

- mains:
32 ±0.2 mm (1.26 ±0.008 in.)
- signal:
24 ±0.2 mm (0.94 ±0.008 in.)

Electrical connection

Via 6 glands fitted to gland plate

Power supply requirements

85 to 265 V AC, 50/60 Hz, 50 VA

Remote range indication

2 volt-free contacts rated 250 V AC, 2 A non-inductive

EMC

Emissions

Conforms to EN61326-1 : 2006

Design and manufacturing standards

CE mark

Electrical safety

BS-EN 61010 – 1 : 2001

Electrical connections

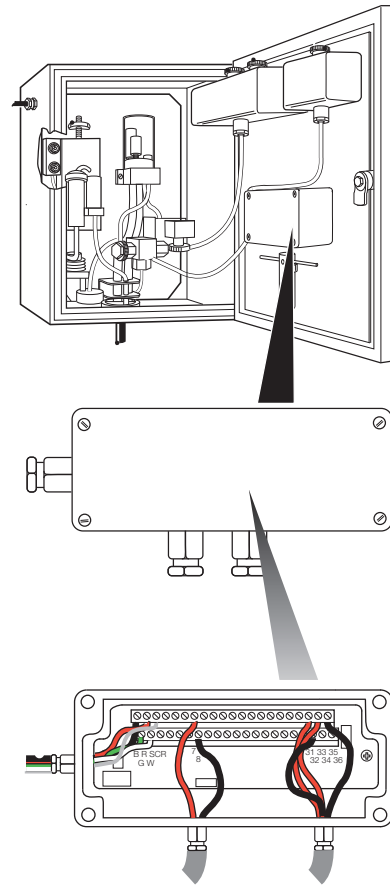
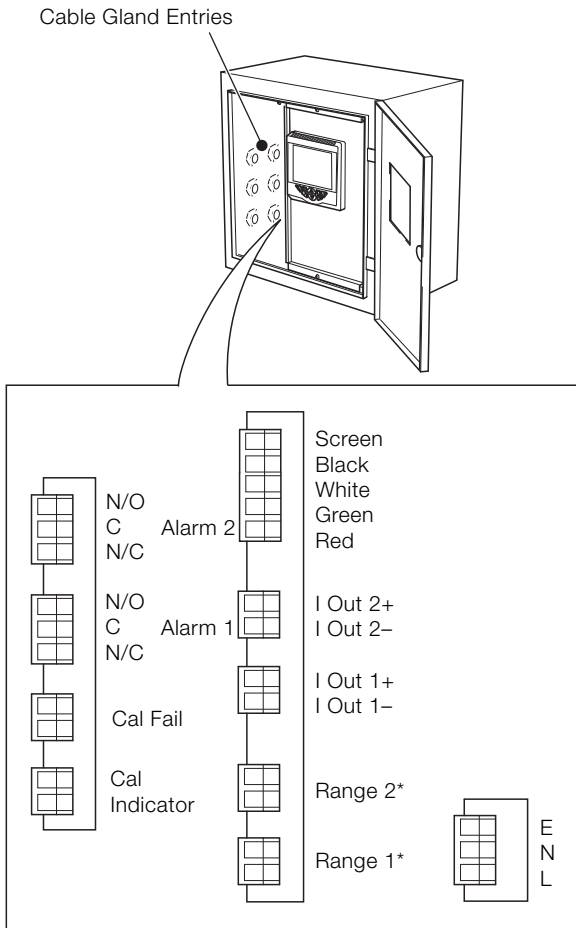

Fig. 7: Transmitter unit cable gland entries and electrical connections

Fig. 9: Sensor connections

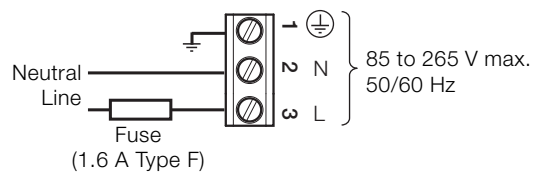

Fig. 8: Power supply connections

7835 Hydrazine monitor

Overall dimensions

Dimensions in mm (in.)

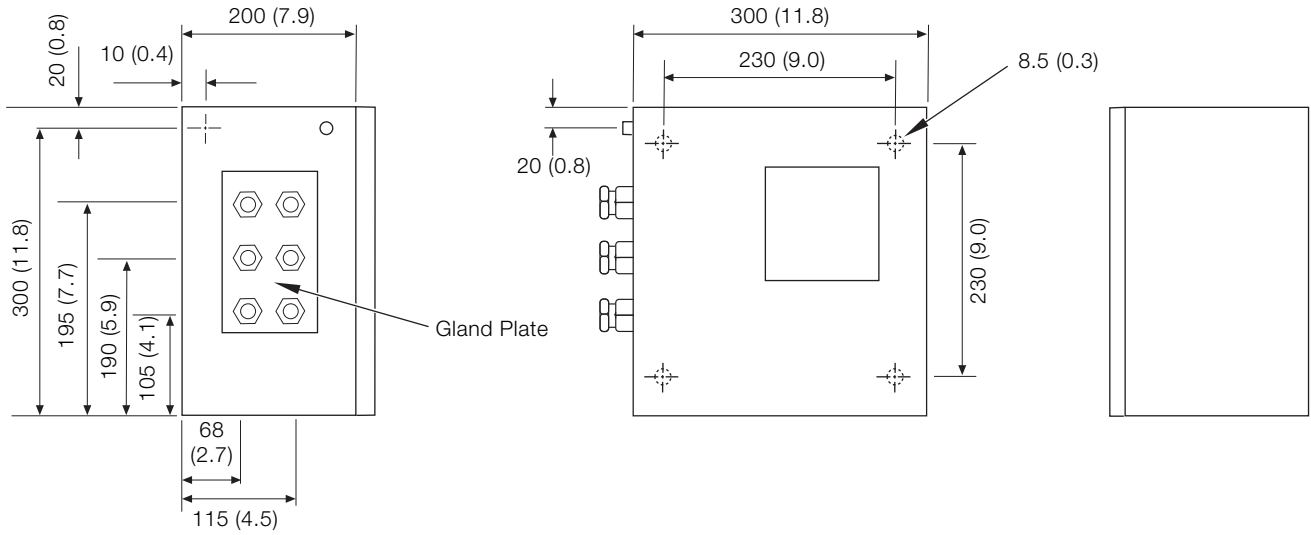

Fig. 10: Transmitter unit dimension and installation detail

Dimensions in mm (in.)

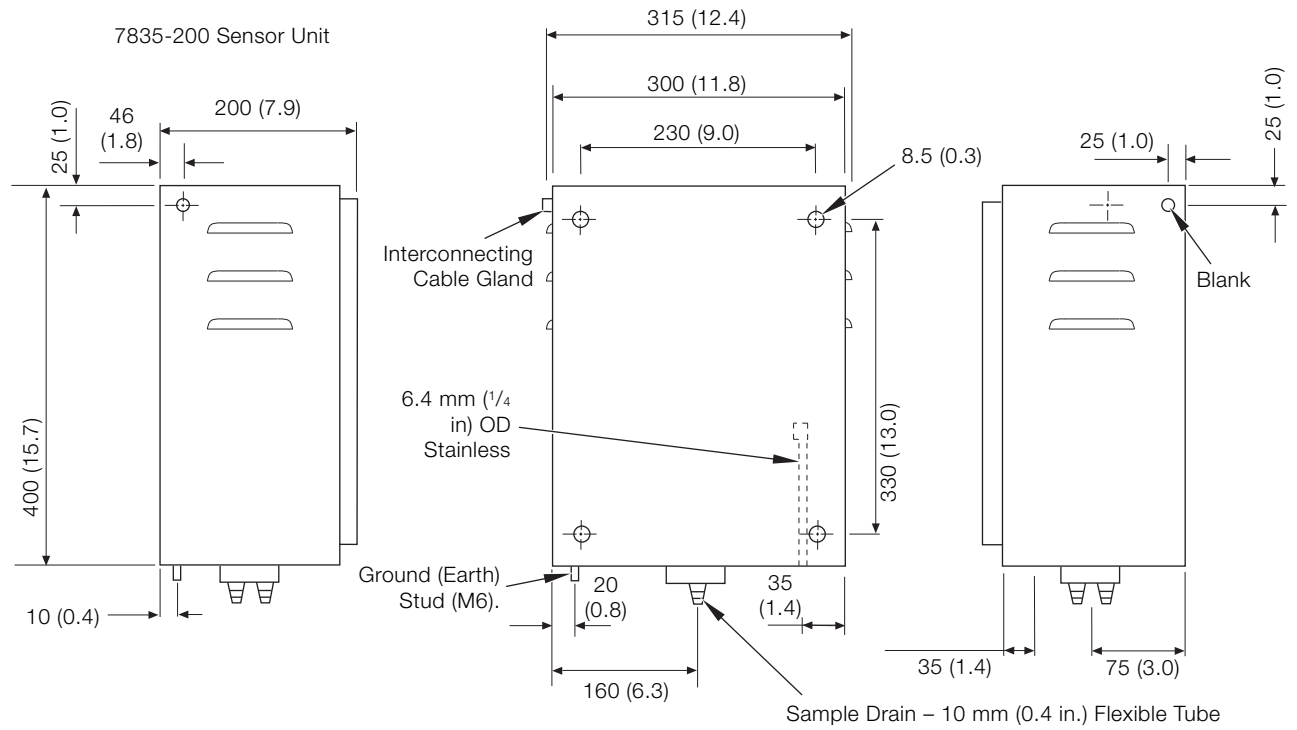

Fig. 11: Sensor unit dimension and installation detail

7835 Hydrazine monitor

Suggested installation layout

Dimensions in mm (in.)

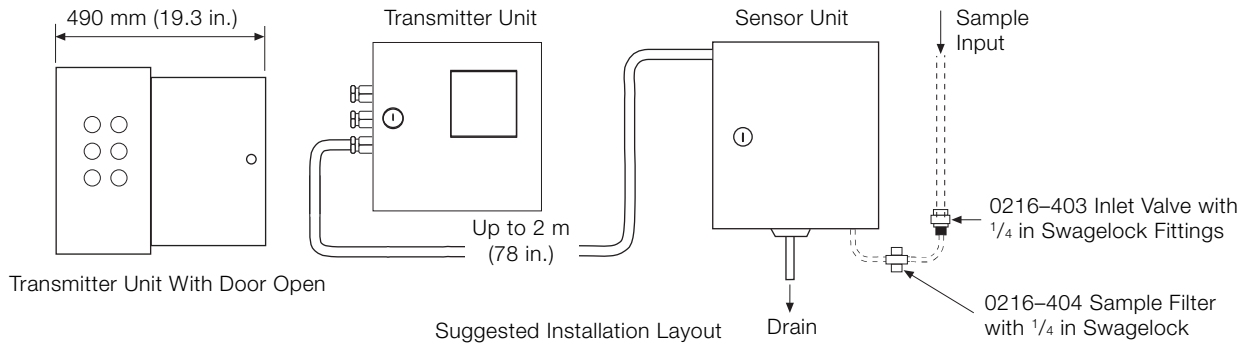

Fig. 12: System layout

Ordering information

Model 7835 Hydrazine Monitor	7835	/X	X	X	X	X	X
Monitor type							
CE monitor with CM30 display	7						
Range							
Low/high auto configurable		0					
Output							
2 off 0/20mA configurable			0				
Power supply							
90/265Vac; 50/60Hz					5		
Language							
English						0	
Build type							
Standard							0

Supplied with monitor:

- Instruction manual
- Hydrazine sensor 7835-385
- 2m (78 in.) of interconnecting cable
- Cell recharging pack 7830-061

Additional options:

- Sample inlet valve 0216-403 (supplied loose) 30 bar (435 psi) max. input pressure 6 mm (1/4 in.) compression fittings.
- Sample filter 0216-404 (supplied loose) 60 micron 6 mm (1/4 in.) compression fittings.
- Hydrazine sensor simulator box. A current source to test the functioning of the transmitter unit 9439-950.

Contact us

ABB Limited

Process Automation

Oldends Lane
Stonehouse
Gloucestershire GL10 3TA
UK

Tel: +44 1453 826 661

Fax: +44 1453 829 671

ABB Inc.

Process Automation

125 E. County Line Road
Warminster
PA 18974
USA

Tel: +1 215 674 6000

Fax: +1 215 674 7183

www.abb.com

Note

We reserve the right to make technical changes or modify the contents of this document without prior notice. With regard to purchase orders, the agreed particulars shall prevail. ABB does not accept any responsibility whatsoever for potential errors or possible lack of information in this document.

We reserve all rights in this document and in the subject matter and illustrations contained therein. Any reproduction, disclosure to third parties or utilization of its contents in whole or in parts – is forbidden without prior written consent of ABB.

Copyright© 2011 ABB

All rights reserved

3KXA848501R1001