

Zirconia Oxygen Analyzer for Small Boiler Applications

AZ100 Series



ABB

The Company

We are an established world force in the design and manufacture of instrumentation for industrial process control, flow measurement, gas and liquid analysis and environmental applications.

As a part of ABB, a world leader in process automation technology, we offer customers application expertise, service and support worldwide.

We are committed to teamwork, high quality manufacturing, advanced technology and unrivalled service and support.

The quality, accuracy and performance of the Company's products result from over 100 years experience, combined with a continuous program of innovative design and development to incorporate the latest technology.

The UKAS Calibration Laboratory No. 0255 is just one of the ten flow calibration plants operated by the Company, and is indicative of our dedication to quality and accuracy.

EN ISO 9001:2000



Cert. No. Q05907

EN 29001 (ISO 9001)



Lenno, Italy – Cert. No. 9/90A

Stonehouse, U.K.



0255

Electrical Safety

This equipment complies with the requirements of CEI/IEC 61010-1:2001-2 'Safety Requirements for Electrical Equipment for Measurement, Control and Laboratory Use'. If the equipment is used in a manner NOT specified by the Company, the protection provided by the equipment may be impaired.

Symbols

One or more of the following symbols may appear on the equipment labelling:

	Warning – Refer to the manual for instructions
	Caution – Risk of electric shock
	Protective earth (ground) terminal
	Earth (ground) terminal

	Direct current supply only
	Alternating current supply only
	Both direct and alternating current supply
	The equipment is protected through double insulation

Information in this manual is intended only to assist our customers in the efficient operation of our equipment. Use of this manual for any other purpose is specifically prohibited and its contents are not to be reproduced in full or part without prior approval of the Technical Publications Department.

Health and Safety

To ensure that our products are safe and without risk to health, the following points must be noted:

1. The relevant sections of these instructions must be read carefully before proceeding.
2. Warning labels on containers and packages must be observed.
3. Installation, operation, maintenance and servicing must only be carried out by suitably trained personnel and in accordance with the information given.
4. Normal safety precautions must be taken to avoid the possibility of an accident occurring when operating in conditions of high pressure and/or temperature.
5. Chemicals must be stored away from heat, protected from temperature extremes and powders kept dry. Normal safe handling procedures must be used.
6. When disposing of chemicals ensure that no two chemicals are mixed.

Safety advice concerning the use of the equipment described in this manual or any relevant hazard data sheets (where applicable) may be obtained from the Company address on the back cover, together with servicing and spares information.

CONTENTS

1	INTRODUCTION	2	8	MECHANICAL INSTALLATION	21
1.1	Principle of Operation	2	8.1	Electronics Unit Siting Requirements	21
2	PREPARATION	3	8.2	Mounting the Electronics Unit	22
2.1	Checking the Probe Code Number	3	8.2.1	Wall-/Pipe-mount Units	22
2.2	Checking the Electronics Unit Code Number	4	8.2.2	Panel-mount Units	23
3	CONTROLS AND DISPLAYS	5	8.3	Probe Siting Requirements	24
3.1	Displays	5	8.4	Mounting the Probe	25
3.2	Key Functions	5	8.4.1	General Requirements	26
4	OPERATION	6	8.4.2	NPT and BSP Mountings	27
4.1	System Start-up	7	8.4.3	Probe Lagging	28
4.2	Operating Page	7	9	ELECTRICAL CONNECTIONS	29
4.3	Operating Page Error Messages	9	9.1	Probe Connections, General	29
5	CALIBRATING THE SYSTEM USING GASES	10	9.1.1	Access to Probe Terminals	29
5.1	System Calibration – Connecting the Air/Test Gas Supply	10	9.1.2	Probe Connections	29
5.2	Oxygen Calibration Page	11	9.2	Access to Terminals	30
5.2.1	Preset Calibration	11	9.2.1	Wall-/Pipe-mount Units	30
5.2.2	Single-point Calibration	12	9.2.2	Panel-mount Units	30
5.2.3	Two-point Calibration	14	9.3	Selecting the Mains Voltage	31
6	PROGRAMMING THE ELECTRONICS UNIT	16	9.3.1	Wall-/Pipe-mount Units	31
6.1	Access to Secure Parameters Page	16	9.3.2	Panel-mount Units	31
6.2	Language Selection Page	16	9.4	Connections, General	32
6.3	Set Up Outputs Page	17	9.4.1	Relay Contact Protection and Interference Suppression	32
7	CALIBRATING THE ELECTRONICS UNIT	19	9.5	Connections, Wall-/Pipe-mount Units	33
7.1	Equipment Required	19	9.6	Connections, Panel-mount Units	33
7.2	Preparation	19	9.7	Connections, Mains Supply Junction Box	34
7.3	Electrical Calibration Page	20			

1 INTRODUCTION

The zirconia oxygen analyzer system is designed to measure oxygen concentration in flue gas by an in situ ('wet analysis') method which avoids the measurement error, typically 20% higher than the actual value, introduced by the sampling system used in a 'dry analysis' method.

The system comprises a flue-mounted oxygen probe containing a zirconia cell and an electronics unit which provides the control necessary for probe operation.

The probe is safe under start-up conditions for all oil and gas boiler fuels, provided the optional flame arrester is fitted. It is also safe for use where groups IIB and IIC gases are present **temporarily** in the flue gas **during fault conditions only**.

The probe is **not** suitable for use on applications where combustible products are **always** present in the flue gas above normal ppm levels.

1.1 Principle of Operation – Fig 1.1

The probe contains a sensing element, comprising a tubular zirconia cell fitted with inner and outer electrodes at the centre. The outer electrode is exposed to the flue gas entering the open end of the cell; the inner electrode is exposed to air and is therefore exposed to a constant partial pressure of oxygen. Since zirconia is an electrolyte which conducts only oxygen ions at temperatures in excess of 600°C, the voltage generated between the electrodes (i.e. the cell output) is a function of the ratio of the oxygen partial pressures across the cell and its temperature. Therefore, any change in the oxygen partial pressure of the flue gas at the exposed electrode produces a change in the cell output voltage as dictated by the Nernst equation:

$$E \text{ (mv)} = 0.0496T(\log_{10} P_0 / P_1) \pm CmV$$

Where: T = Absolute temperature
P₀ = Reference O₂ partial pressure
P₁ = Sample O₂ partial pressure
C = Cell constant (mV zero offset)
0.0496 = Faraday's gas constant

Cell output voltage decreases logarithmically with increasing oxygen, thus giving high sensitivity at low oxygen levels.

A heater element, controlled by the electronics unit, maintains the cell temperature at 700°C.

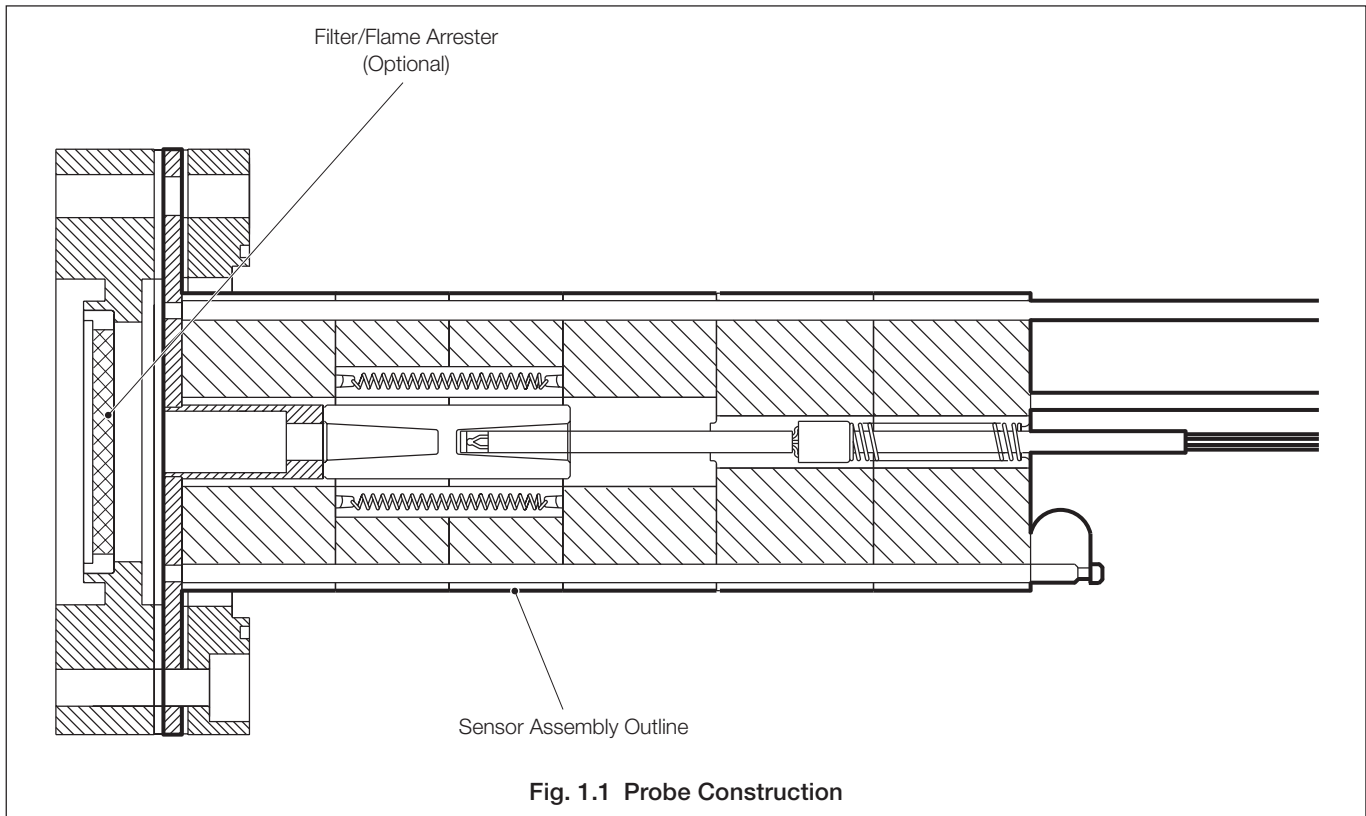
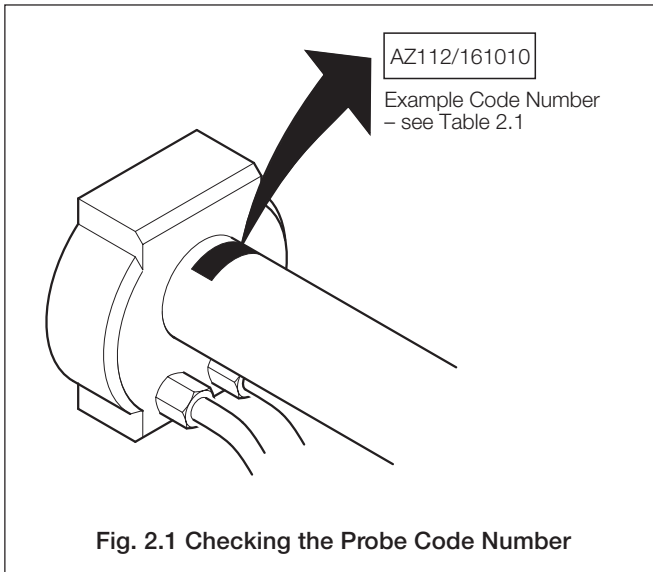

Fig. 1.1 Probe Construction

2 PREPARATION

2.1 Checking the Probe Code Number – Fig. 2.1



AZ100 Series Zirconia Oxygen Analyzer for Small Boiler Applications	AZ1	X	X/	X	X	X	X	X	X
Probe									
Not required		0							
No purge with arrester		2							
Sample Tube Length									
200mm sample tube			1						
350mm sample tube			2						
500mm sample tube			3						
650mm sample tube			4						
Probe Mount									
Not required				0					
2 in. NPT				1					
2 in. BSP				2					
Transmitter									
Not required					0				
230V Wall-mount					1				
230V Post-mount					2				
230V Panel-mount					3				
115V Wall-mount					4				
115V Post-mount					5				
115V Panel-mount					6				
Signal Cable									
Not required						0			
10m						1			
25m						2			
50m						3			
100m (maximum)						4			
Approvals									
CE only							0		
Language									
English									1
German									2
French									3
Spanish									4
Configuration									
ABB (Standard)									0

Table. 2.1 Checking the Probe Code Number

2.2 Checking the Electronics
Unit Code Number – Fig. 2.2

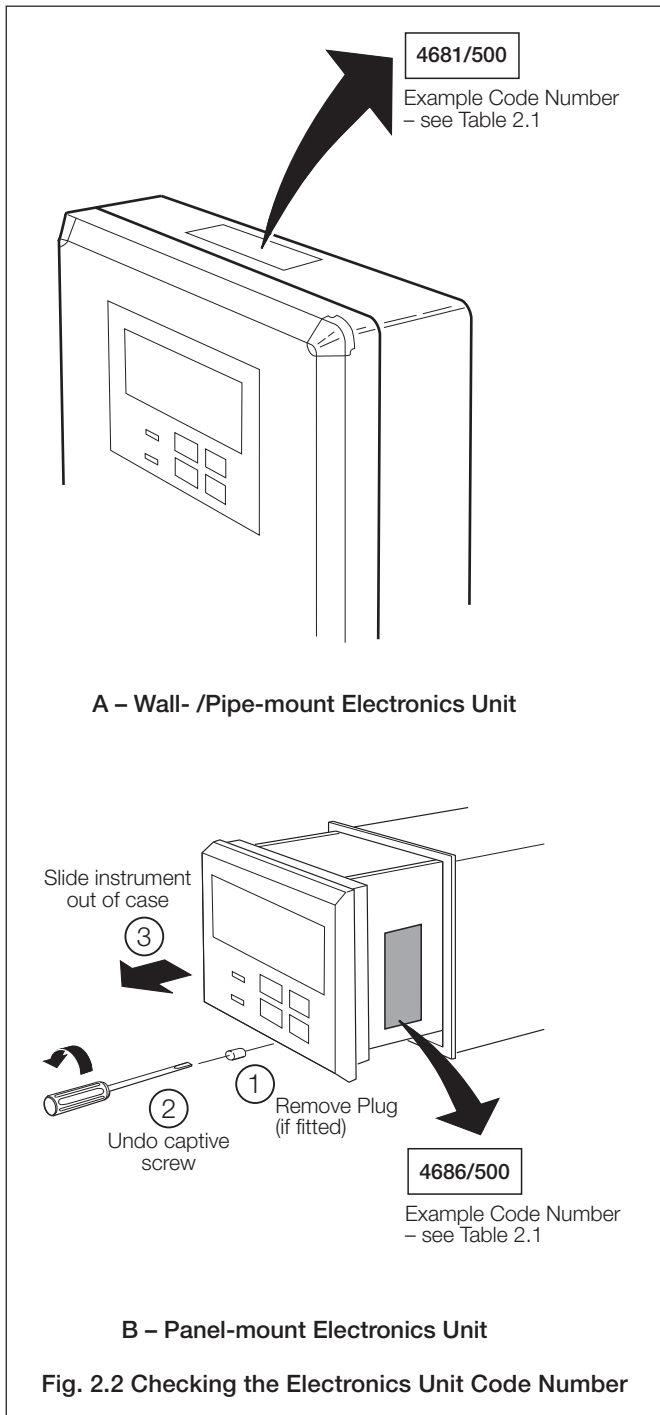
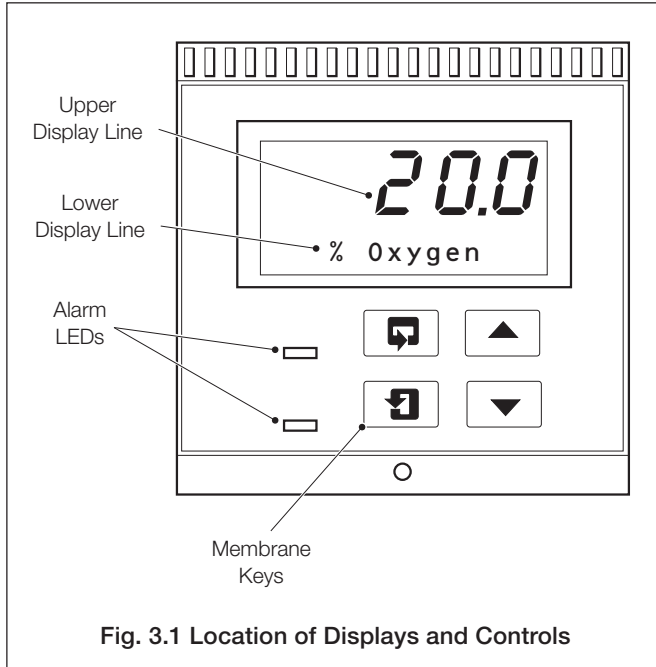

Fig. 2.2 Checking the Electronics Unit Code Number

3 CONTROLS AND DISPLAYS

3.1 Displays – Fig. 3.1

The display comprises a 5-digit, 7-segment digital upper display line and a 16-character dot-matrix lower display line. In operation, the upper display line shows actual values of % oxygen, temperature, cell millivolts or alarm set points. In programming mode it is used to display programmable parameters. The lower display line shows the units of measurement and/or other programming information.



3.2 Key Functions – Fig. 3.2

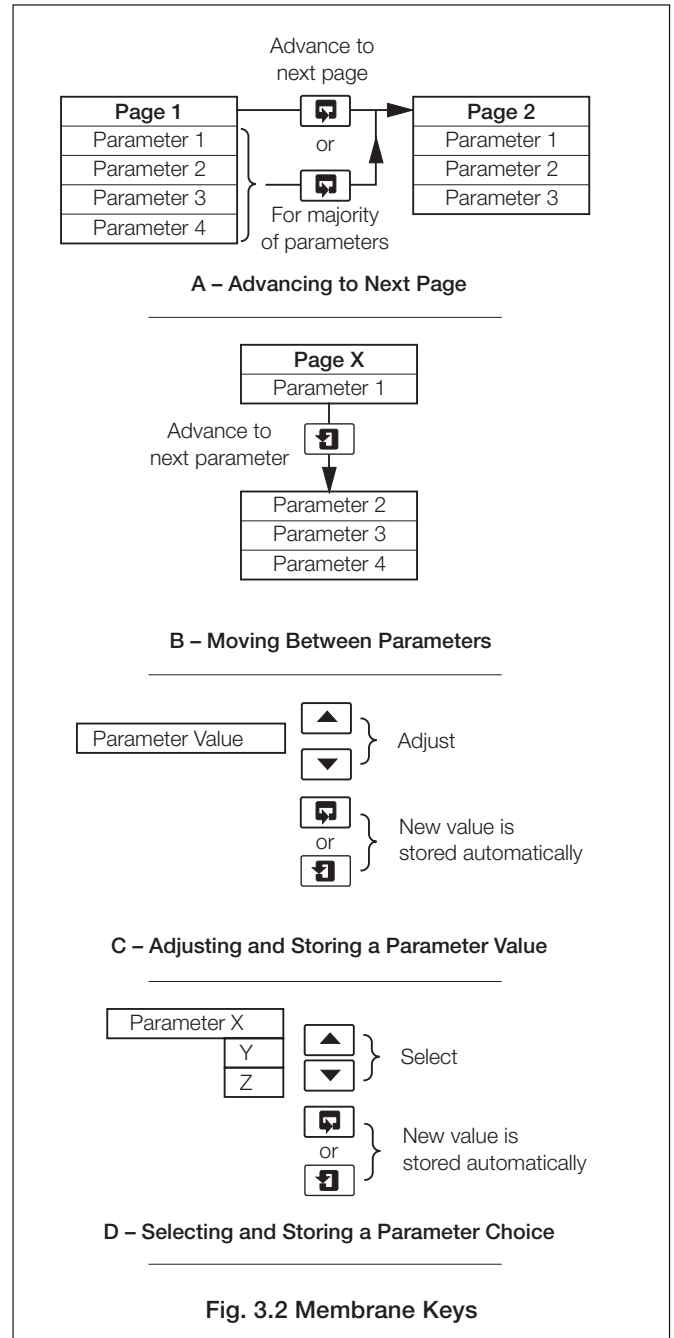

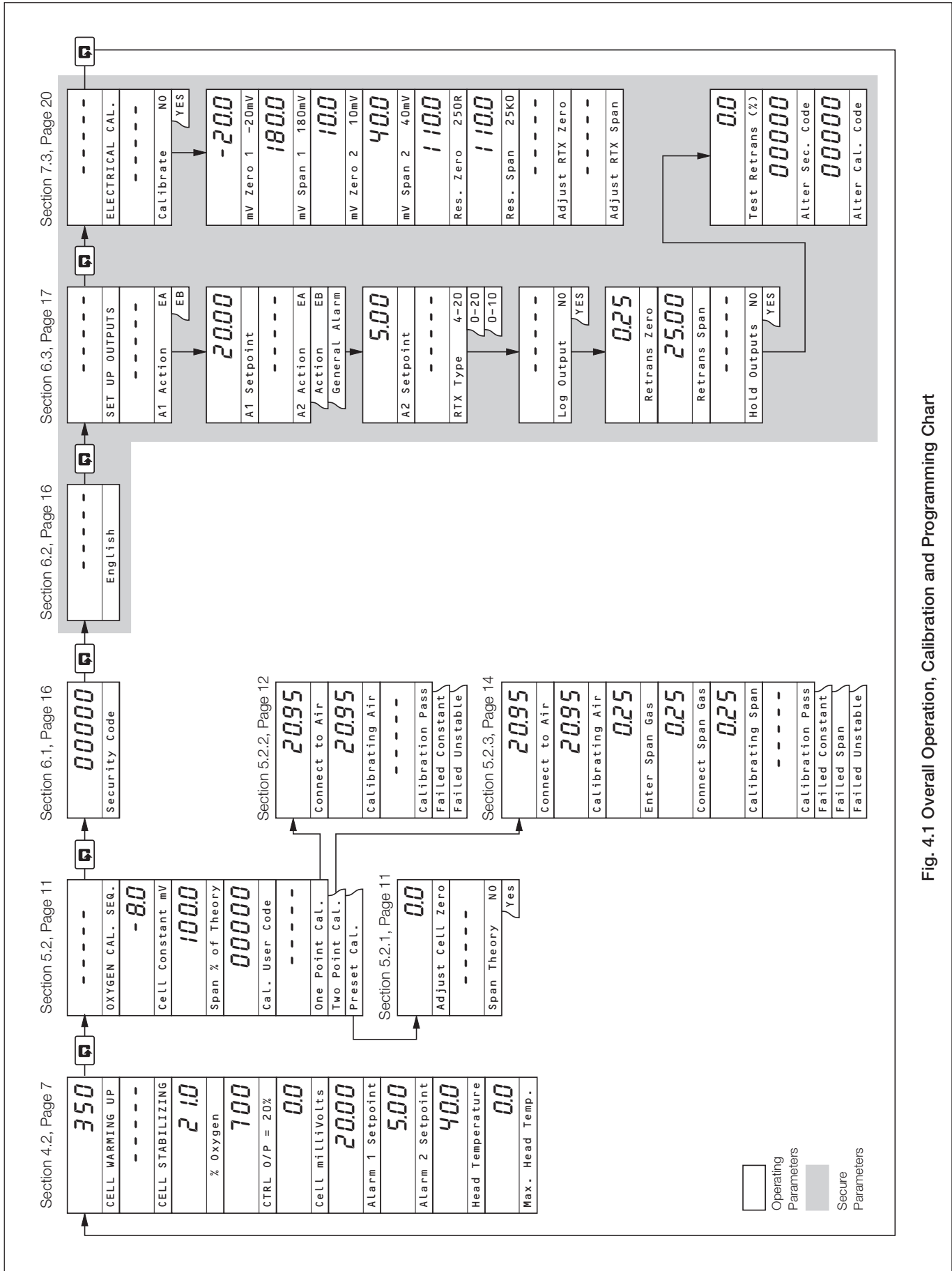

Fig. 4.1 Overall Operation, Calibration and Programming Chart

4.1 System Start-up

Ensure all electrical connections have been made correctly and apply power to the system probe and electronics unit.

4.2 Operating Page

The Operating Page is a general use page in which continuously updated measured values and preset parameters can be viewed but not altered. To adjust or set a parameter refer to the Programming Pages in Section 7.

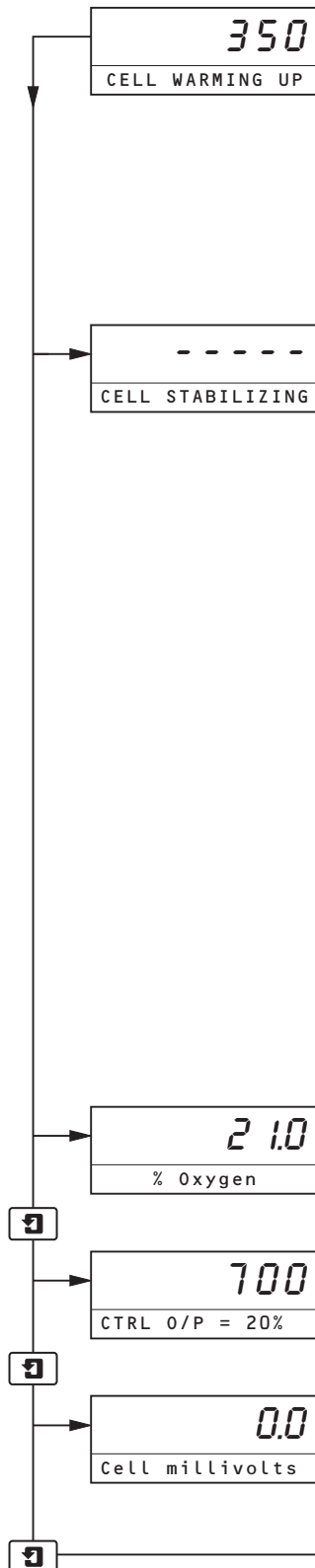

Cell Warming Up

Displayed when the system is first powered up from cold – see also Table 4.1 (page 8).

Measured cell temperature displayed.

When the cell temperature reaches 690°C the procedure advances automatically.

Warning. If the probe heater temperature exceeds 850°C at any time, immediately switch off the power supply to the probe and electronics and contact ABB.

Cell Stabilizing

After a five minute delay to allow the cell output to stabilize, the display advances automatically to the %Oxygen parameter unless a fault is detected – see **Note** below and Table 4.1 (page 8).

Note. During the start up procedure, the cell heater and thermocouple are monitored for correct operation. If a fault is detected, the cell heater is switched off and one of the following error messages is displayed:

T/C OPEN CIRCUIT	} see Table 4.1 for possible cause.
T/C REVERSED	
CHECK T/C	

If **T/C REVERSED** is displayed, the lower dot matrix display toggles between the following:

T/C REVERSED	– displayed for 4 seconds	} Repeated
CHECK CONNECTION	– displayed for 2 seconds	
PRESS ▼ TO RESET	– displayed for 2 seconds	

If **CHECK T/C** is displayed, the lower dot matrix display toggles between the following:

CHECK T/C	– displayed for 4 seconds	} Repeated
CHECK CONNECTION	– displayed for 2 seconds	
PRESS ▼ TO RESET	– displayed for 2 seconds	

In both instances, check the wiring between the probe and electronics unit. When the problem is resolved, press the  key to resume operation.

% Oxygen

The upper display indicates the measured oxygen value. If over- or under-temperature is monitored, the upper display shows '-----' and an error message is displayed on the lower dot matrix display – see Table 4.1.

Control Output (%)

The upper display indicates the probe heater temperature in °C

The lower display indicates the probe heater control mark/space ratio.

Cell Millivolts

The upper display indicates the measured cell millivolts.

Continued on next page...

...4.2 Operating Page

Continued from previous page

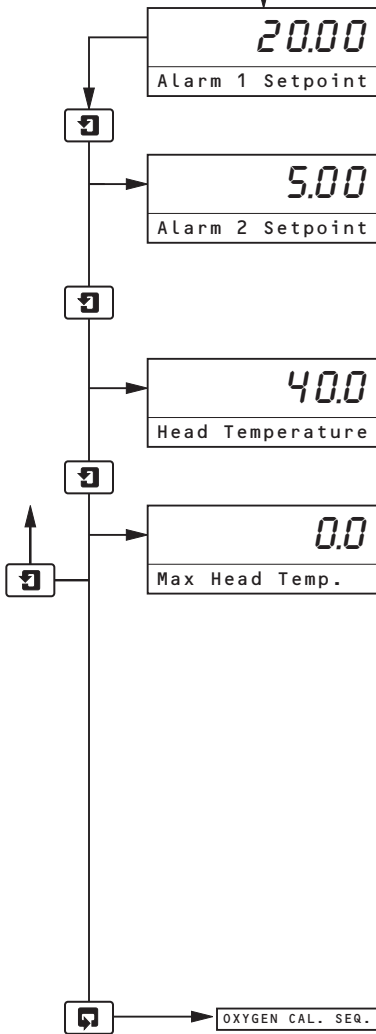

Alarm 1 Set Point

The upper display indicates the Alarm 1 Set Point, displayed as % oxygen. The set point value and the relay/LED action are programmed in the **Set Up Outputs Page** – see Section 6.3.

Alarm 2 Set Point

Note. This frame is not displayed if the 'Alarm 2 Action' parameter has been set to 'General Alarm' – see Section 6.3.

The upper display indicates the Alarm 2 Set Point, displayed as % oxygen.

Head Temperature

The upper display indicates the temperature within the probe terminal head.

Maximum Head Temperature

The upper display indicates the maximum temperature attained within the probe terminal head.

0.0 is shown unless the temperature within the probe terminal head has exceeded 105°C.

Press the  key to reset the maximum head temperature reading back to 0.0. If the reading does not return to zero, the temperature within the probe terminal head continues to exceed 105°C.

Note. If 105°C is exceeded and Alarm 2 is programmed as a general system/instrument alarm, the alarm is activated, the probe heater is de-energized and the front panel LED illuminated.

Press  to return to the top of the **Operating Page**.

Press  to advance to **Oxygen Calibration Page**.

Note. If the cell is stabilizing or has not reached normal working temperature, calibration is prevented and pressing  advances to the **Security Code Page**.

4.3 Operating Page Error Messages – Table 4.1

If an error has been detected, the relevant error message (see Table 4.1) appears in the **Operating Page**, in place of the % Oxygen display .

Error Message	Possible Cause
NV MEMORY ERROR	The contents of the non-volatile memory have not been read correctly during power up. To rectify the fault, switch off, wait 10 seconds and switch on again. If the fault persists contact the Company.
CELL WARMING UP	The probe oven has not reached a sufficient temperature to obtain suitable readings (<690°C, 1274°F).
CELL STABILIZING	After the cell temperature reaches 690°C (1274°F), a delay of five minutes is allowed for the cell output to stabilize.
CALIBRATION FAIL	The last single- or two-point calibration failed.
T/C OPEN CIRCUIT*	The thermocouple connections are open circuit or the thermocouple temperature is > 1000°C (1832°F).
T/C REVERSED*	The thermocouple has been connected in reverse.
CHECK T/C*	The probe oven power supply has failed or there is a short circuit in the thermocouple wiring or the thermocouple has been connected in reverse.
HEAD TEMP ALARM*	The temperature within the probe terminal head has exceeded 105°C

* The electronics unit also switches off the cell heater if any of these faults are detected.

Table 4.1 Operating Page Error Messages

5 CALIBRATING THE SYSTEM USING GASES

5.1 System Calibration – Connecting the Air/Test Gas Supply – Fig. 5.1

Notes.

- For accurate calibration using test gases, carry out the procedure with the probe mounted in its operational position and with the process at its normal operating conditions.
- During a single- and two-point calibration, air (single-point calibration) or air and a certified test gas (two-point calibration) must be connected to the probe when instructed – see Sections 5.2.2 and 5.2.3.
- Clean, dry air must be used, supplied from a compressed air system, a pressurized cylinder or a diaphragm type pump (e.g. aquarium aeration pump) capable of a minimum flow rate of 5 litres per minute.

Connect the air or test gas supply as shown in Fig. 5.1.

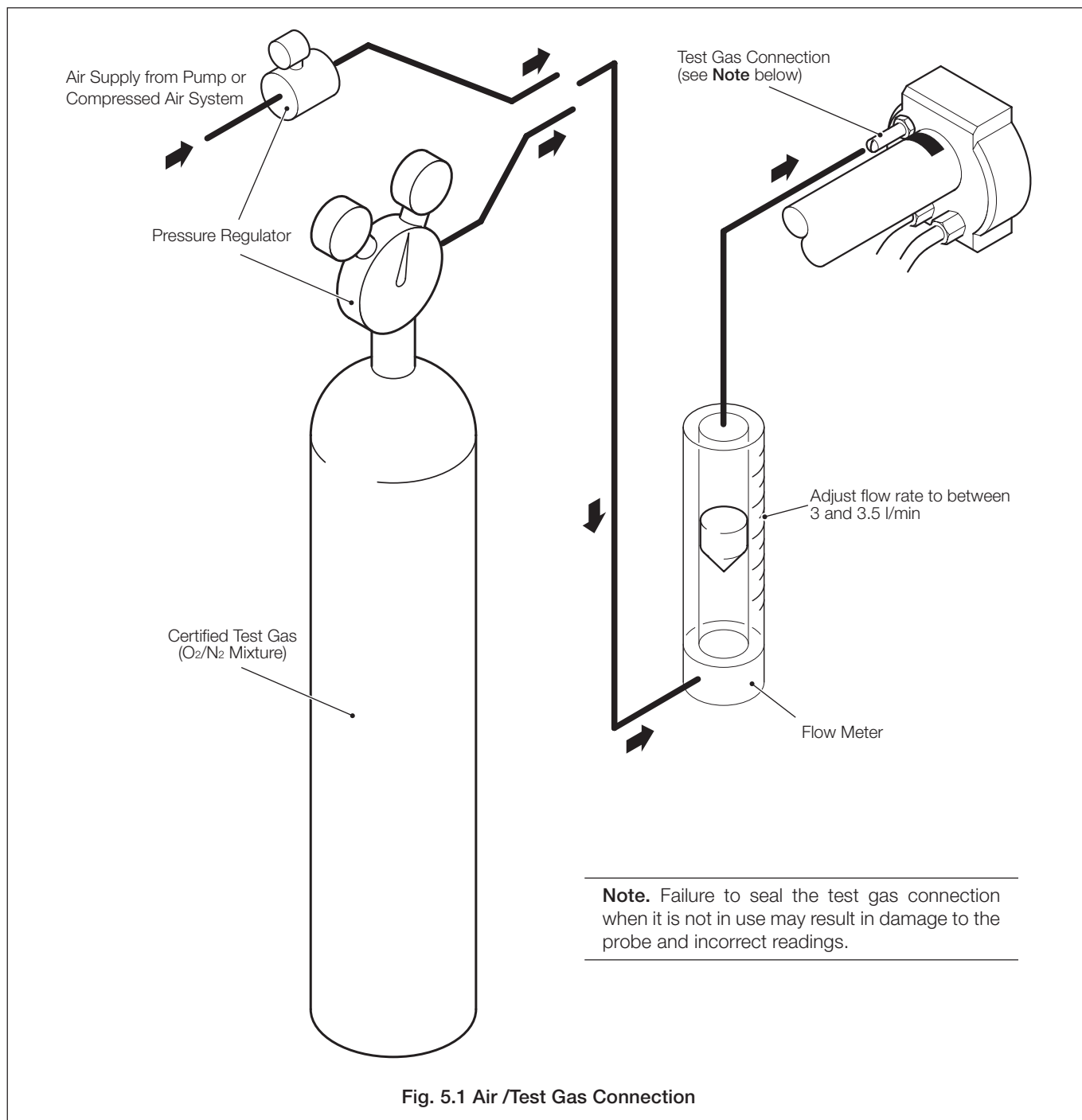

Note. Before commencing a gas calibration procedure, the electronics unit and probe must be switched on and allowed to operate for at least one hour to allow the system to stabilize thermally.

5.2 Oxygen Calibration Page
5.2.1 Preset Calibration

Note. Carry out a preset calibration following probe installation from new or after replacement of the sensor assembly.

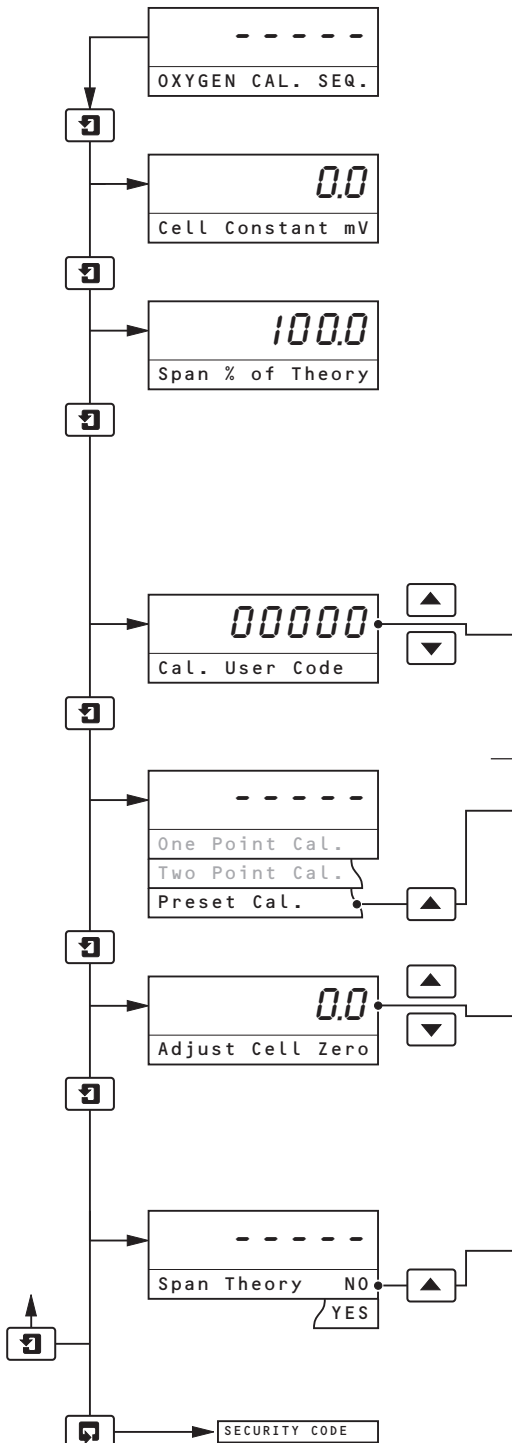

Oxygen Calibration Sequence

Cell Zero mV

The upper display shows the millivolt offset of the oxygen probe from the last successful calibration.

Span % of Theory

The upper display indicates the oxygen probe output slope using parameters derived at the last two-point calibration or using the preset values.

If the last two-point calibration was successful, a value between 90 and 110% is displayed.

If the last two-point calibration was unsuccessful, a value of <90 or >110% is displayed.

Calibration User Code

[00000 to 19999] programmed in the **Set Up Outputs Page** – see Section 6.3.

If an incorrect value is entered, access to the calibration page is inhibited and the display returns to the top of the Oxygen Calibration Sequence.

Preset Calibration

Select the preset calibration sequence.

Adjust Cell Zero

[0 to ±20mV]

The upper display shows the cell output (in mV) corresponding to a reading of 20.95 %O₂. Adjust the reading to correspond with the probe cell zero offset mV.

Note. The cell zero value can be found on the probe zero value sheet provided with the probe sensor assembly.

Span Theory

Select **YES** if recalibrating after fitting a new cell/sensor assembly.

Select **NO** to retain the existing value.

Press **→** to return to the top of the **Oxygen Calibration Page**.

Press **↩** to advance to the **Access to Secure Parameters Page**.

...5 CALIBRATING THE SYSTEM USING GASES

...5.2 Oxygen Calibration Page

5.2.2 Single-point Calibration

Note. Carry out a single-point calibration

- If the probe cell zero is unknown.
- Following probe maintenance.

A single-point calibration sequence involves standardizing the electronics unit and probe, using air. Until a calibration sequence has been completed successfully, the existing slope remains unaffected.

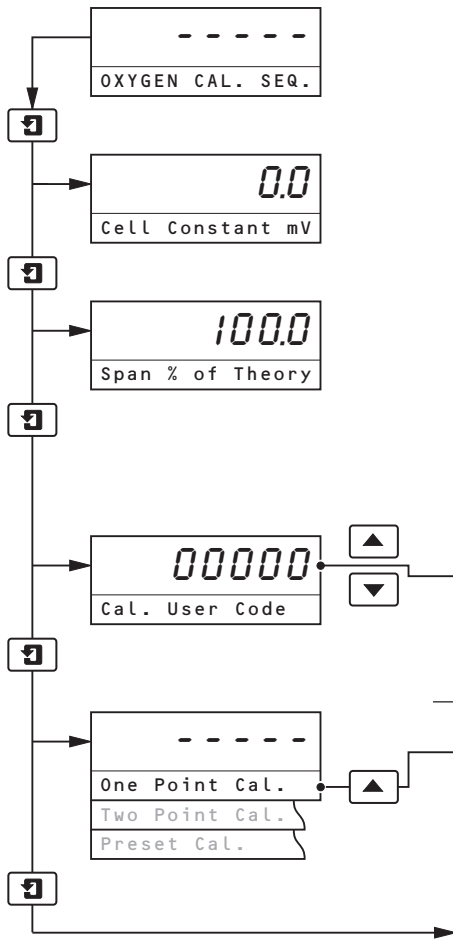

Oxygen Calibration Sequence

Cell Constant mV

The upper display shows the millivolt offset of the oxygen probe from the last successful calibration.

Span % of Theory

The upper display indicates the oxygen probe output slope using parameters derived at the last two-point calibration or using the preset values.

If the last calibration was successful, a value between 90 and 110% is displayed.

If the last calibration was unsuccessful, a value <90 or >110% is displayed.

Calibration User Code

[00000 to 19999] programmed in the **Set Up Outputs Page** – see Section 6.3.

If an incorrect value is entered, access to the calibration page is inhibited and the display returns to the top of the Oxygen Calibration Sequence.

One Point Calibration

Select the one-point calibration sequence.

Continued on next page...

...5.2 Oxygen Calibration Page

...5.2.2 Single-point Calibration

Continued from previous page

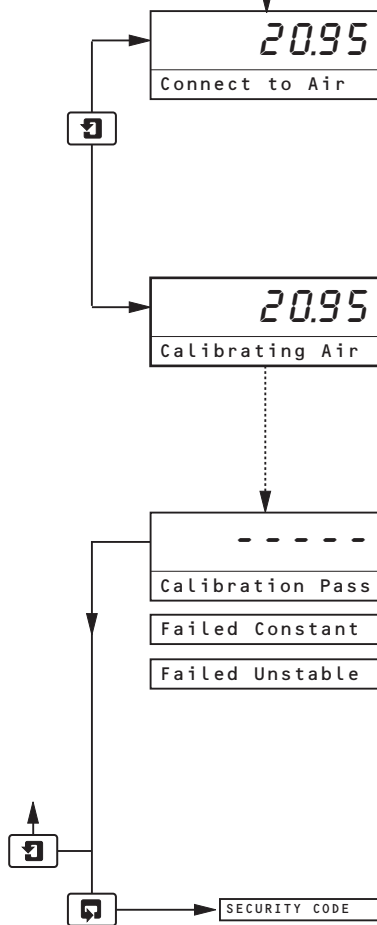

Connect to Air

Connect the air supply to the probe's test gas inlet and adjust the flow rate to 3 litres per minute – see Section 5.1.

Note. An alternative to supplying air to the probe's test gas inlet is to allow the process to run such that air only is present in the flue, i.e. with burners off and fans running. This condition will need to be maintained for the duration of the calibration process – approximately 5 minutes.

Calibrating Air

The upper display indicates the % oxygen content of the air supply.

The procedure advances automatically when a stable and accurate reading is obtained from the probe.

To abort calibration, press either the or key to advance to the next frame.

Calibration Pass/Fail

When calibration is completed, a status message is displayed:

Calibration Pass	Calibration sequence successful
Failed Constant	Cell offset >±20mV (upper display shows cell mV output)
Failed Unstable	Cell output unstable (drifting).

Note. If the sensor calibration is unsuccessful then the 'Cell Constant mV' and 'Span % of Theory' parameters are unaffected. The electronics unit continues to operate using parameters stored during the last successful calibration.

Press to return to the top of the **Oxygen Calibration Page**.

Press to advance to the **Access to Secure Parameters Page**.

...5 CALIBRATING THE SYSTEM USING GASES

...5.2 Oxygen Calibration Page

5.2.3 Two-point Calibration

Note. Carry out a two-point calibration if maximum possible system accuracy is required – refer to Data Sheet SS/AZ100.

A two-point calibration sequence involves standardizing the electronics unit and probe using air and a certified test gas. Until a calibration sequence has been completed successfully, the existing slope remains unaffected.

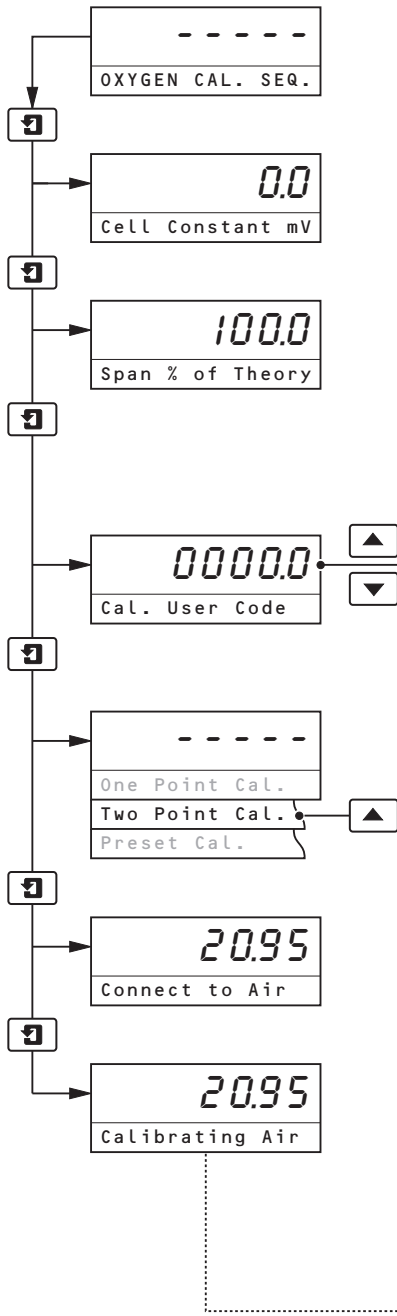

Oxygen Calibration Sequence

Cell Constant mV

The upper display shows the millivolt offset of the oxygen probe from the last successful calibration.

Span % of Theory

The upper display indicates the oxygen probe output slope using parameters derived at the last two-point calibration or using the preset values.

If the last calibration was successful, a value between 90 and 110% is displayed.

If the last calibration was unsuccessful, a value <90 or >110% is displayed.

Calibration User Code

[00000 to 19999] programmed in the **Set Up Outputs Page** – see Section 6.3.

If an incorrect value is entered, access to the calibration page is inhibited and the display returns to the top of the Oxygen Calibration Sequence.

Two Point Calibration

Select the two-point calibration sequence.

Connect to Air

Connect the air supply to the probe's test gas inlet and adjust the flow rate to 3 litres per minute (see Section 5.1).

Calibrating Air

The upper display indicates the % oxygen content of the air supply.

The procedure advances automatically when a stable and accurate reading is obtained from the probe.

To abort calibration, press either the or key to advance to the next frame.

Continued on next page...

...5.2 Oxygen Calibration Page
 ...5.2.3 Two-point Calibration

Continued from previous page

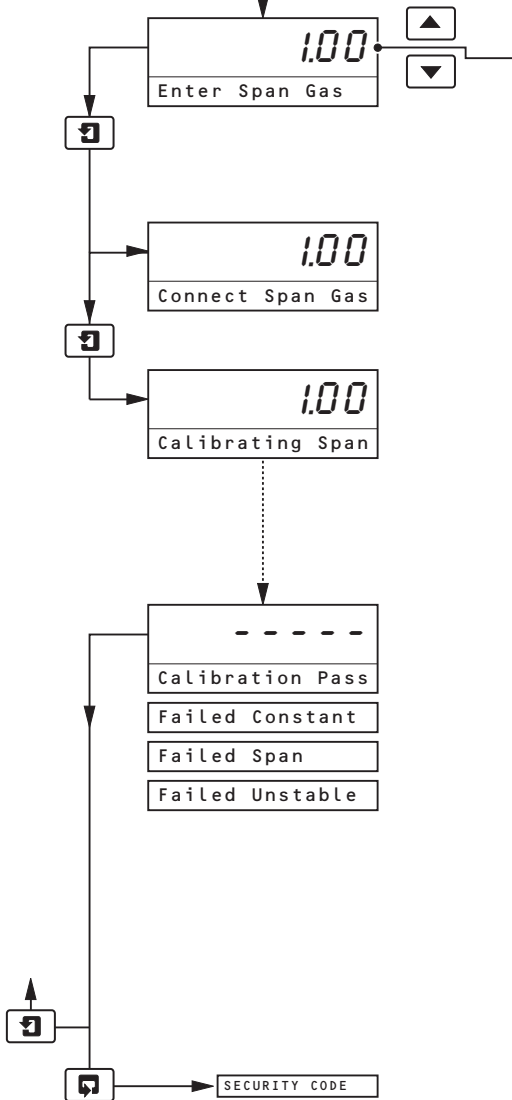

Enter Span Gas O₂ Value

[between 0.10 and 10.00% Oxygen]

Enter the certified oxygen content of the test gas used to calibrate the span.

Note. To obtain the most accurate readings, the O₂ value of the span gas should be as near as is practically possible to the process O₂ value.

Connect Span Gas

Connect the certified test gas to the probe's test gas inlet and adjust the flow rate to 3 litres per minute – see Section 5.1.

Calibrating Span

The upper display indicates the % oxygen content of the certified test gas.

The procedure advances automatically when a stable and accurate reading is obtained from the probe.

To abort calibration, press either the or key to advance to the next frame.

Calibration Pass/Fail

When calibration is completed, a status message is displayed:

Calibration Pass	Calibration sequence successful
Failed Constant	Cell offset >±20mV (upper display shows cell constant)
Failed Span %	Cell output <90% or >110% of slope (upper display shows measured slope)
Failed Unstable	Cell output unstable (drifting).

Note. If sensor calibration is unsuccessful, the 'Cell Zero mV' and 'Span % of Theory' parameters are unaffected. The instrument continues to operate using parameters stored during the last successful calibration.

Press to return to the top of the Oxygen Calibration Page.

Press to advance to the Secure Parameters Page.

6 PROGRAMMING THE ELECTRONICS UNIT

6.1 Access to Secure Parameters Page

A 5-digit security code is used to prevent tampering with the secure parameters.

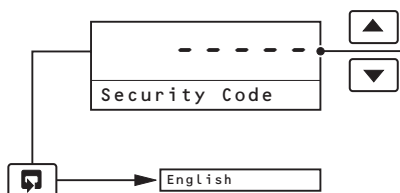

Security Code

[00000 to 99999]

Set in the **Set Up Outputs Page** – see Section 6.3.

If an incorrect value is entered, access to programming pages is inhibited.

Press  to advance to the **Language Selection Page**.

6.2 Language Selection Page

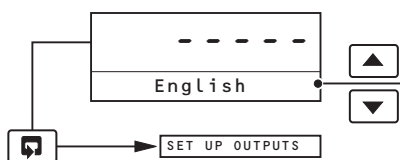

Language Selection

Select the language in which all text is subsequently displayed:

English

Press  to advance to the **Set Up Outputs Page**.

6.3 Set Up Outputs Page

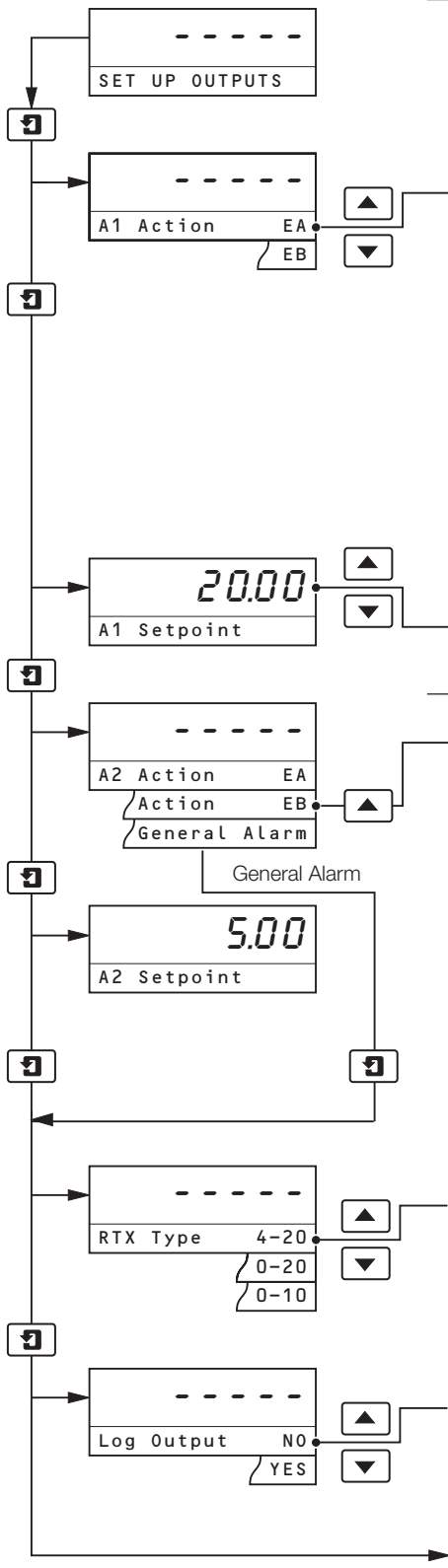

Set Up Outputs

Alarm A1 Action

Select the required alarm action from the following table:

Alarm Action	LED Action		Relay Action	
	Input Above Set Point	Input Below Set Point	Input Above Set Point	Input Below Set Point
EB	ON	OFF	DE-ENERGIZED	ENERGIZED
EA	OFF	ON	ENERGIZED	DE-ENERGIZED

The set point band is defined as the actual value of the Set Point plus or minus the hysteresis value. The hysteresis value is fixed at 0.1% of set point. Alarm action occurs if the input value is above or below the Set Point band. If the input moves within the Set Point band the last alarm action is maintained.

Alarm 1 Set Point

The alarm set point can be set to any value within the oxygen range. [0.00% to 25.00%]

Alarm A2 Action

Set the required alarm action from the above table.

If the alarm action is set to **General Alarm**, the relay is de-energized and the associated front panel i.e.d. is illuminated when one or more of the following conditions applies: thermocouple open circuit, cell warming up, calibration fail, cell stability check, power failure.

Alarm A2 Set Point

The alarm set point can be set to any value within the oxygen range of 0.3% to 25.0%.

Note. This frame is not displayed if the 'Alarm 2 Action' parameter has been set to **General Alarm**.

Retransmission Type

The retransmission output is assigned to the oxygen range.

Select the retransmission output current range required (4 to 20mA, 0 to 20mA or 0 to 10mA).

Logarithmic or Linear Output

The retransmission can be assigned to give a logarithmic or linear output.

Select the output required:

- YES - Logarithmic
- NO - Linear

Continued on next page

...6.3 Set Up Outputs Page

Continued from previous page

Retransmission Zero
Set the required retransmission zero value, in % oxygen units.
[0% to 20.00% (linear output)]
or
[0.1% to 0.25% (logarithmic output)].

Retransmission Span
Linear Output – Set the required retransmission span value, in % oxygen units. The retransmission span value must be at least 5% above the retransmission zero value.
[5% to 25.00%]
Logarithmic Output – The retransmission span is preset to two decades above the zero value and cannot be adjusted. For example, if the zero is set to 0.2%, the span is preset to 20.00% .

Hold Outputs
The retransmission and alarm outputs can be held to prevent inadvertent operation during a test gas calibration sequence.

Test Retransmission
The electronics unit transmits a test signal of 0, 25, 50, 75 and 100% of the retransmission range selected above. The % test signal selected is shown on the upper display.

Example – when the Retransmission Type parameter is set to '0-20' (mA) and the Test Retransmission signal is set to '50%', the retransmission output value is forced to 10mA.

Alter Security Code
[00000 to 99999]
Set the security code used to prevent tampering with the secure parameters – see Section 6.1.

Alter Calibration Code
[00000 to 99999]
Set the code used to gain access to the system calibration facility – see Section 5.2.

Press to return to the top of the **Set Up Outputs Page**.

Press to advance to the **Electrical Calibration Page**.

7 CALIBRATING THE ELECTRONICS UNIT

Note. The electronics unit is calibrated by the company prior to despatch and further calibration is not normally necessary. High stability components are used in the electronics unit's circuitry and, once calibrated, it is unlikely that the calibration will change over time. However, if inaccurate or inconsistent readings are obtained, follow the procedures detailed in this Section.

7.1 Equipment Required

- Millivolt source (cell input simulator), -20.0 to 180.0mV .
- Millivolt source (temperature input simulator), 10.0 to 40.0mV .
- Digital voltmeter (current output), 0 to 20mA .
- Decade resistance box (ACJC simulator), 0 to 100k .

7.2 Preparation

- Switch off the mains supply. Disconnect the probe and retransmission output terminations from the electronics unit – see Fig. 8.6 (wall-/pipe-mount unit) or Fig. 8.7 (panel-mount unit).
- Connect the millivolt sources and the decade resistance box to the appropriate terminals – see Fig. 7.1.
- Connect the digital voltmeter to the retransmission terminals – see Fig. 9.8 (wall-/pipe-mount unit) or Fig. 9.9 (panel-mount unit).
- Refit all covers, switch on the mains supply to the electronics unit and allow ten minutes for the circuits to stabilize.
- Select the **Electrical Calibration Page** and proceed as detailed in Section 7.3.

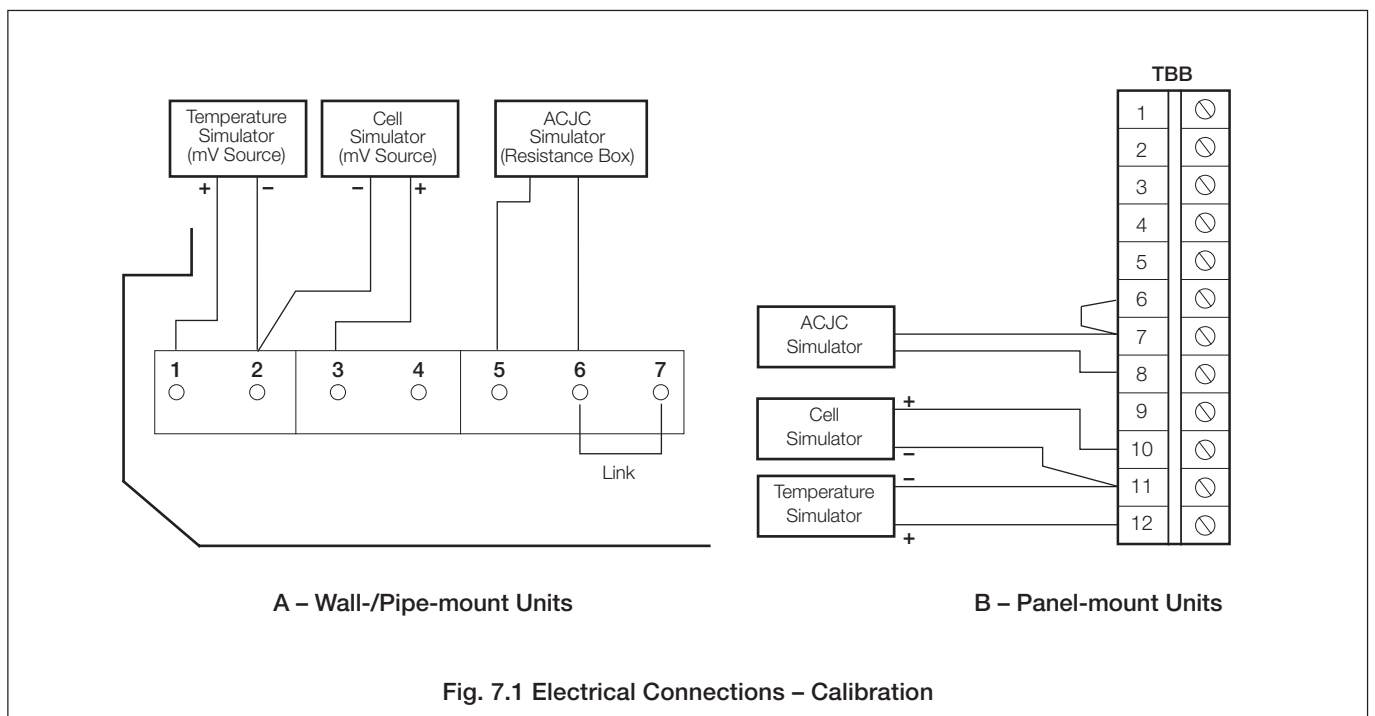

7.3 Electrical Calibration Page

When carrying out the electrical calibration procedure, the actual values denoted by **XXXXXX** are unimportant and are used only to determine display reading stability.

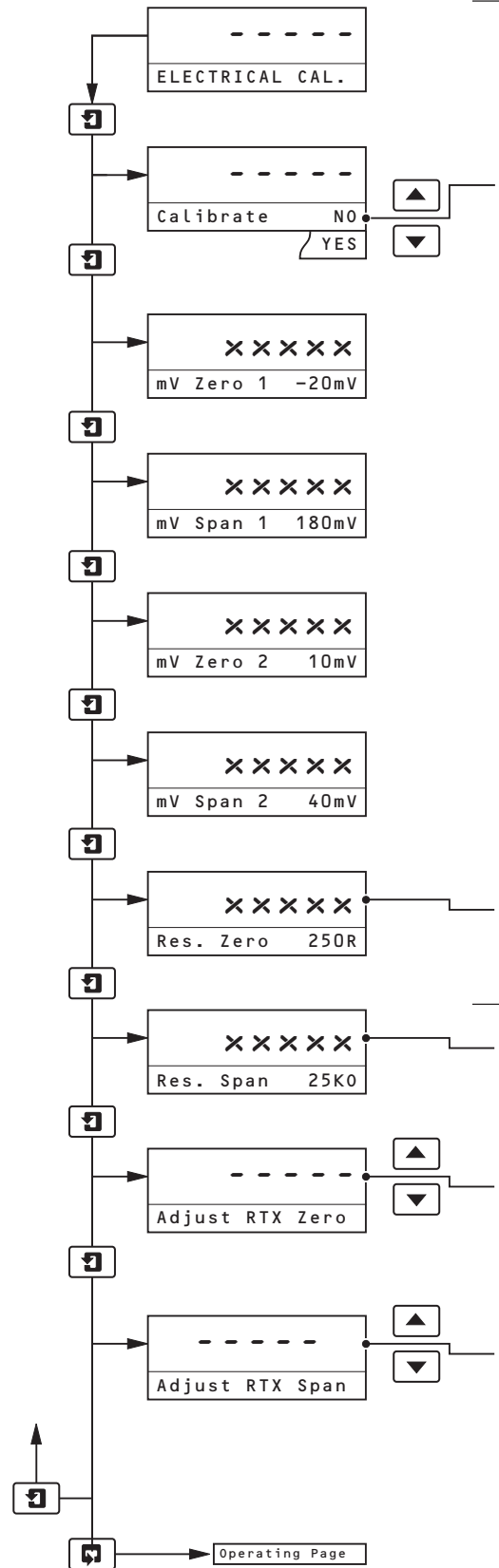

Electrical Calibration Page

Calibrate

Select **YES** to access the electrical calibration sequence. Select **NO** to advance to the **Adjust RTX Zero** parameter below.

mV Zero 1

Set the Cell simulator millivolt source to **-20mV** and allow the display to stabilize.

mV Span 1

Set the Cell simulator millivolt source to **180mV** and allow the display to stabilize.

mV Zero 2

Set the Temperature simulator millivolt source to **10mV** and allow the display to stabilize.

mV Span 2

Set the Temperature simulator millivolt source to **40mV** and allow the display to stabilize.

Resistance Zero (250R)

Set the ACJC simulator decade resistance box to **250R** and allow the display to stabilize.

Resistance Span (25k)

Set the ACJC simulator decade resistance box to **25k** and allow the display to stabilize.

Adjust RTX Zero

Set the milliammeter reading to **4mA**.

Note. The **Retransmission Type** selected in the **Set Up Outputs Page** (see Section 6.3) does not affect the reading.

Adjust RTX Span

Set the milliammeter reading to **20mA**.

Note. The **Retransmission Type** selected in the **Set Up Outputs Page** (see Section 6.3) does not affect the reading.

Press **↩** to return to the top of the **Electrical Calibration Page**.

Press **➡** to advance to the **Operating Page**.

8 MECHANICAL INSTALLATION

8.1 Electronics Unit Siting Requirements

Caution.

- Mount in a location free from excessive vibration.
- Mount away from harmful vapours and/or dripping fluids.

Note. Mount the electronics unit at eye level whenever possible to allow an unrestricted view of the front panel displays and controls.

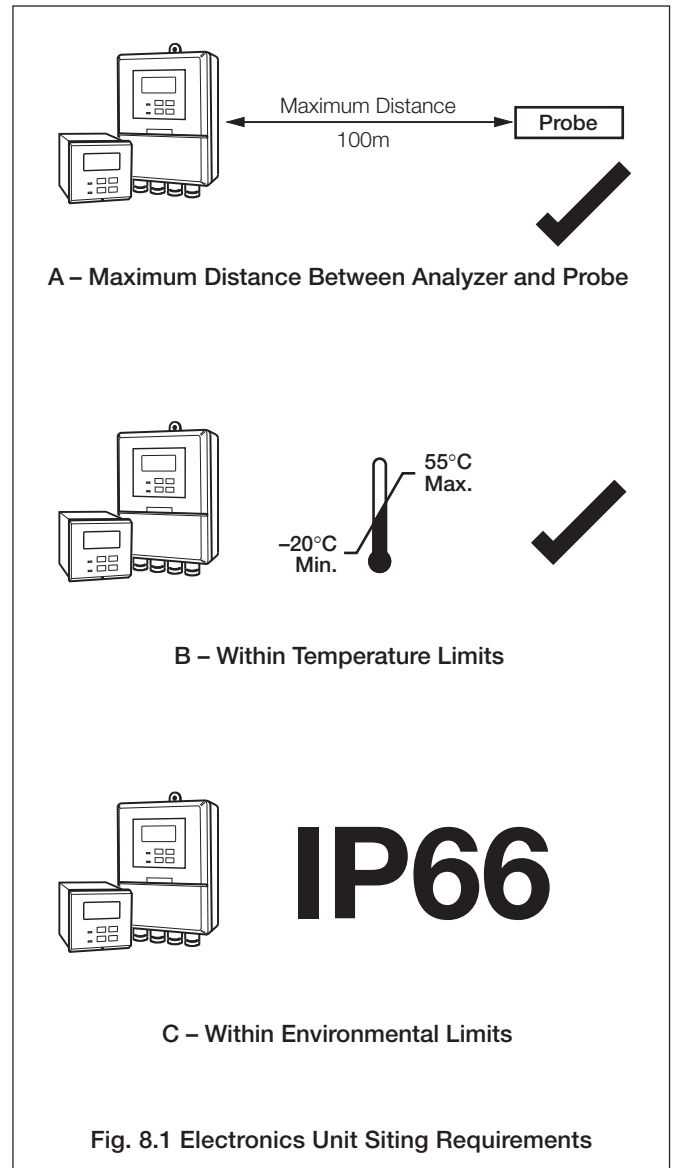

8.2 Mounting the Electronics Unit

8.2.1 Wall-/Pipe-mount Units – Figs. 8.2 and 8.3

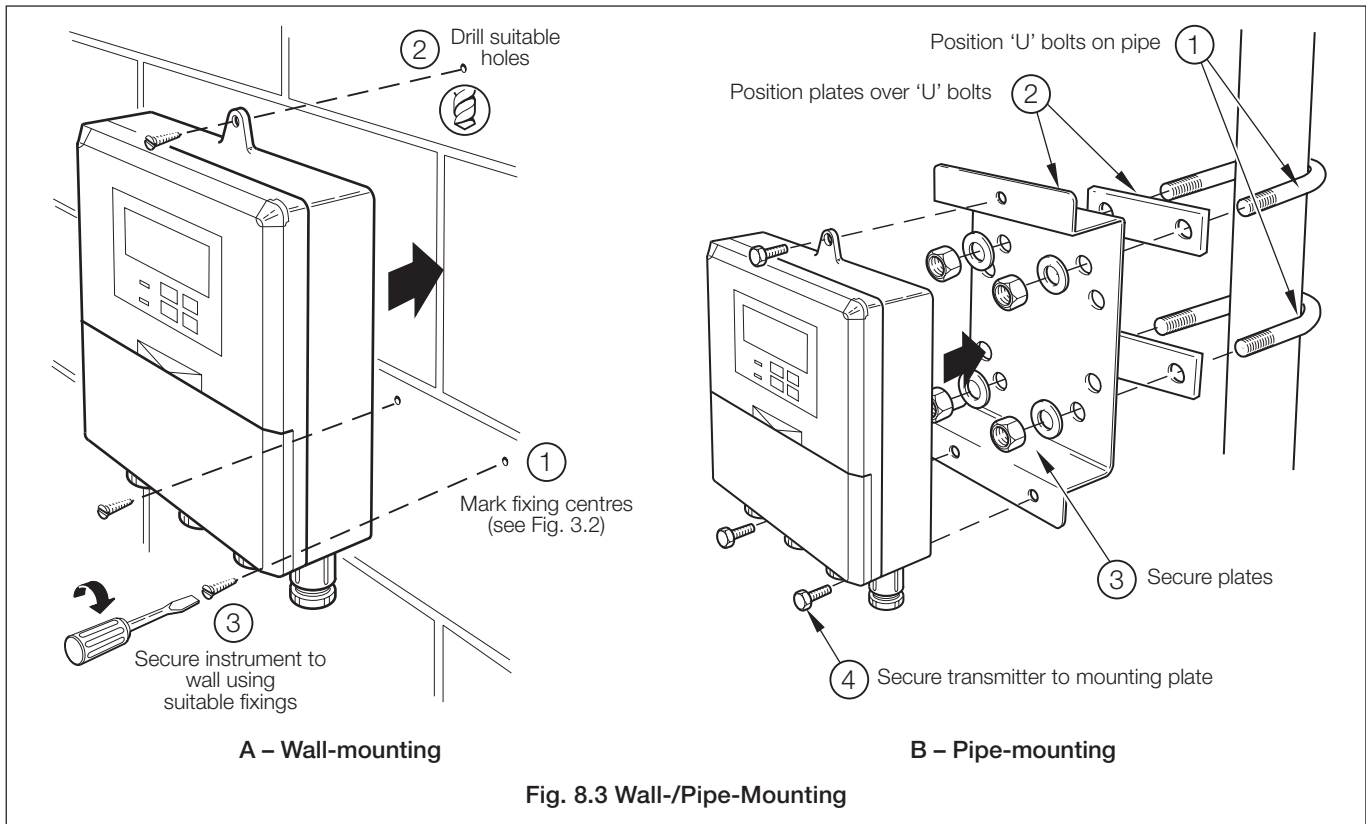
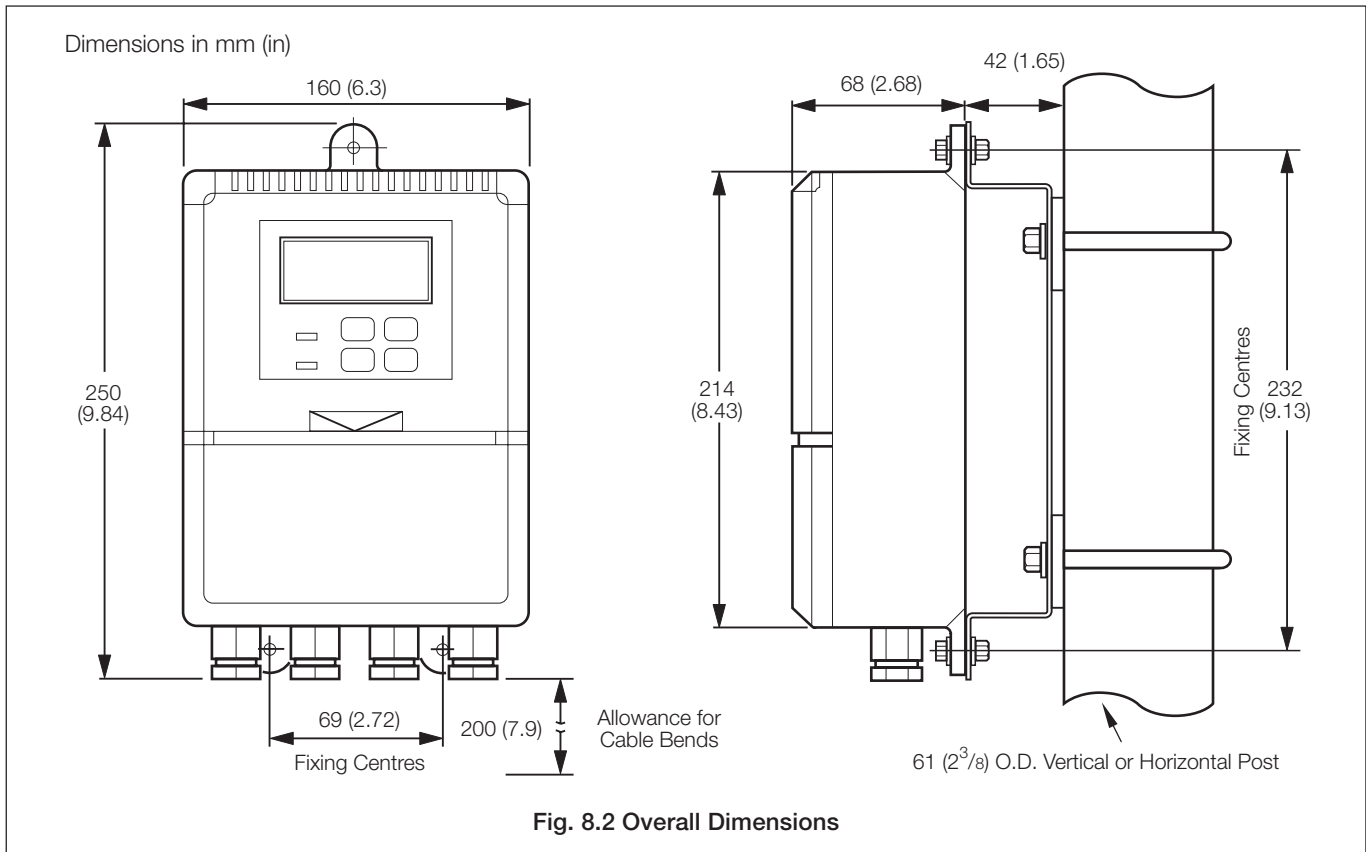

...8.2 Mounting the Electronics Unit

8.2.2 Panel-mount Units – Figs. 8.4 and 8.5

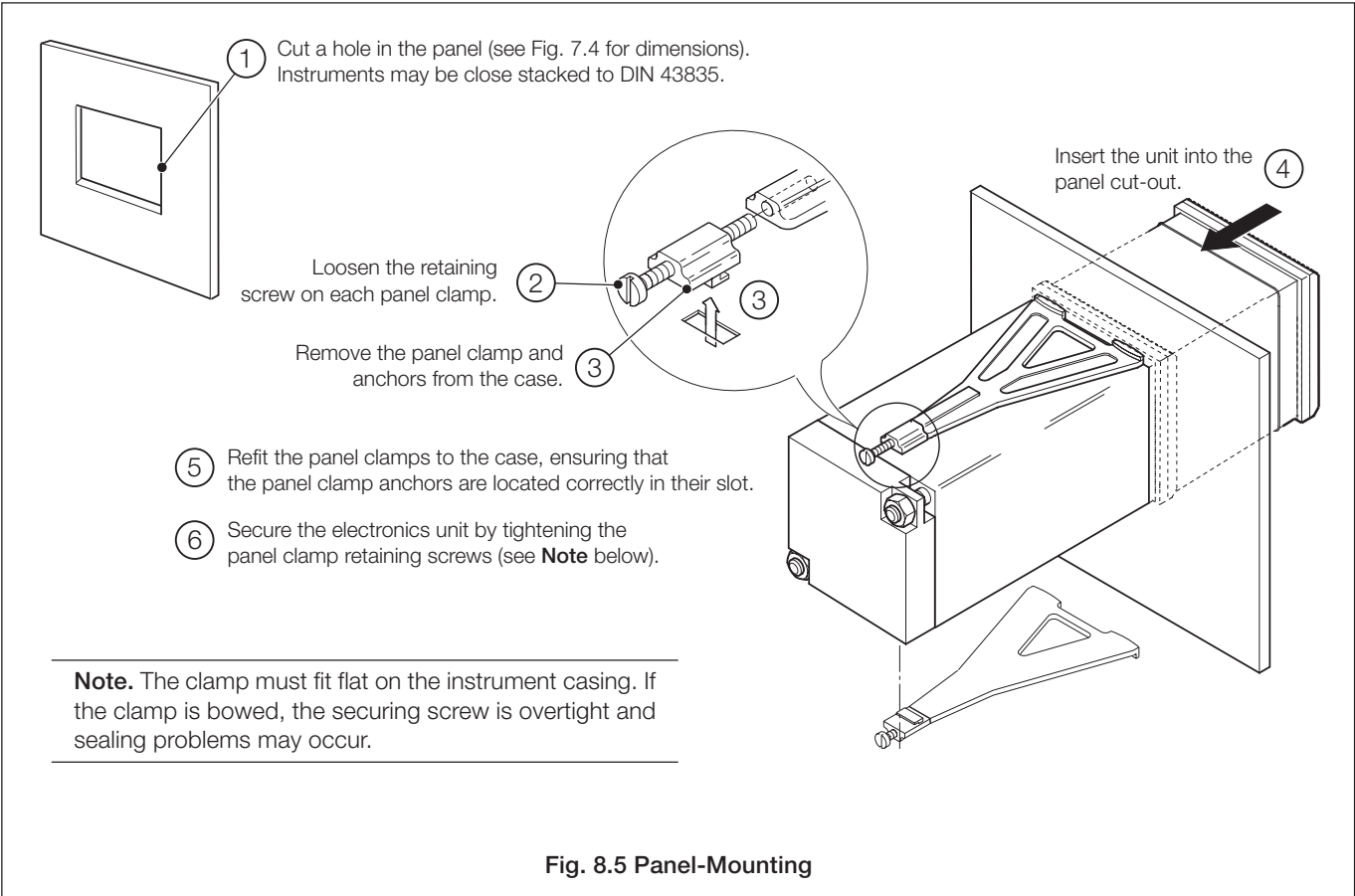
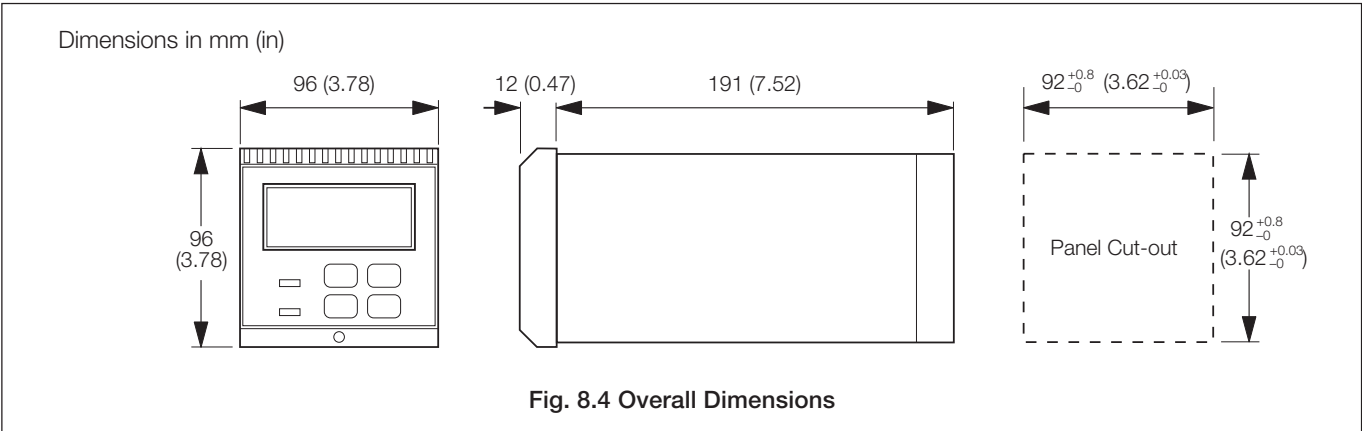

8.3 Probe Siting Requirements

Caution.

- Handle the probe with care. The probe inners have fragile ceramic components which are easily damaged.
 - The probe must only be used with clean, ash-free process gases.
 - Thermal shock may break the zirconia cell if the flue is cleaned using water. If this method of cleaning is employed, remove the probe from the flue prior to cleaning.
-

Select a position where the intake is located in the main stream of flue gas. Gas temperature must be in the range 20°C to 600°C. The surface temperature of the duct must not exceed 400°C.

Avoid positions where obstructions or bends prevent insertion (and subsequent removal) of the probe.

Avoid positions where either vibration levels induced by other plant or vortex shedding of the probe could result in mechanical failure of the probe.

The probe mounting flange and body must be thermally lagged if the temperature of the flue wall and probe mounting flange is <150°C when the process is operating to prevent acid dew-point corrosion.

Maintain the probe terminal head temperature within the range -10° to 80°C (14° to 176°F).

Caution. Do not exceed the probe terminal head maximum operating temperature. Care must be taken to site the probe in an area where the ambient air temperature is less than 70°C and where radiated heat from the flue does not cause the maximum temperature to be exceeded.

Probe dimensions are shown in Fig 7.2. A clearance of at least 25mm in excess of the overall probe length is necessary for installation or removal procedures.

8.4.1 General Requirements – Fig. 8.7

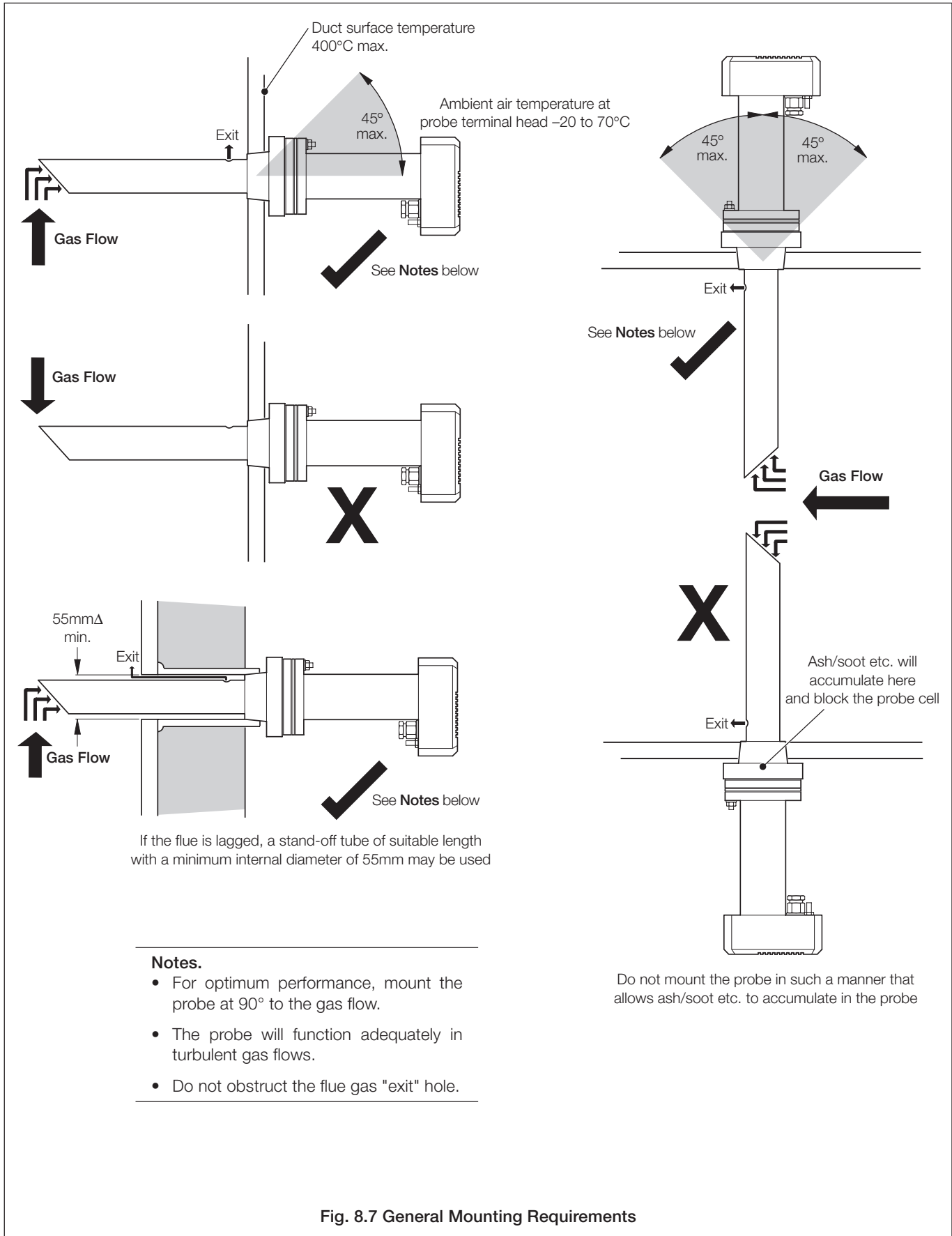
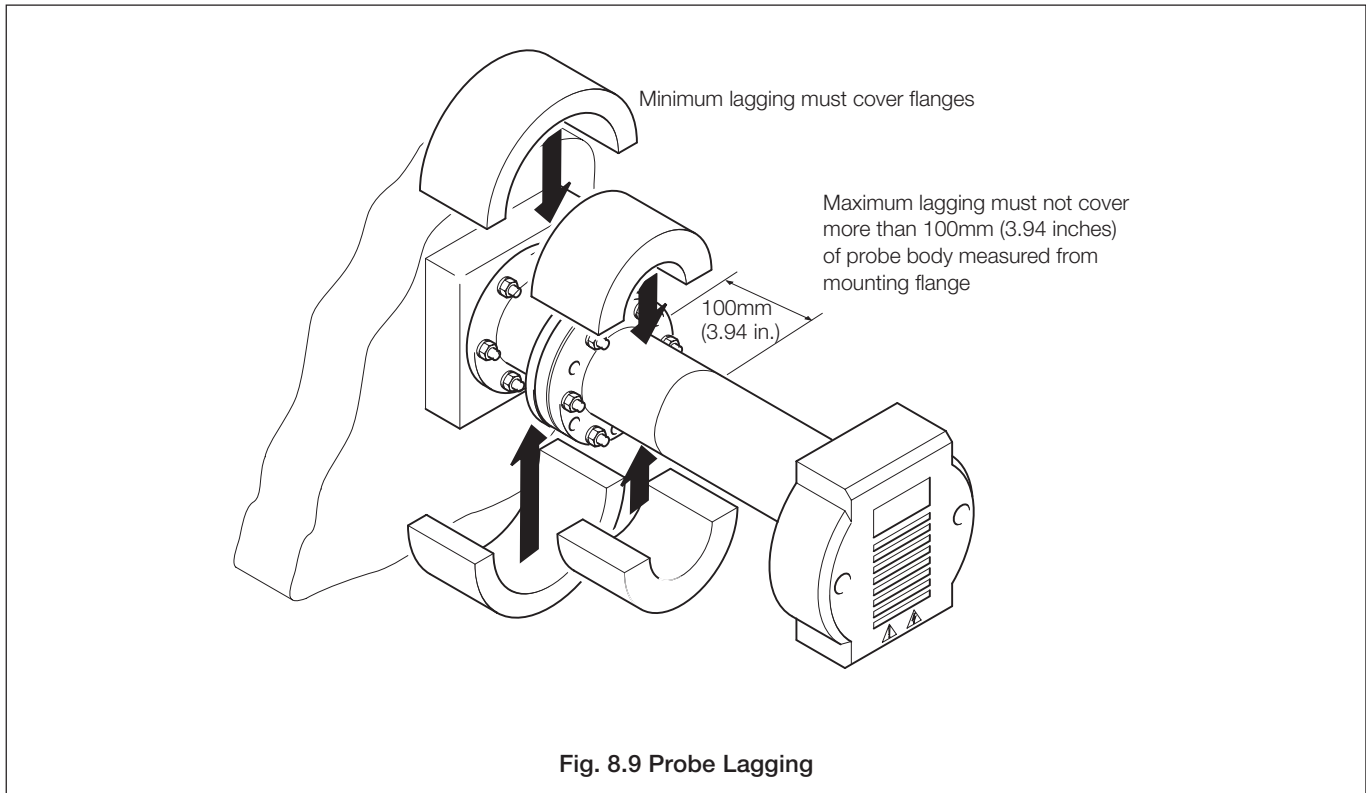

Fig. 8.7 General Mounting Requirements

8.4.3 Probe Lagging – Fig. 8.9

If the normal operating temperature of the flue wall is $<150^{\circ}\text{C}$, the probe mounting flange and body must be thermally lagged to prevent acid dew-point corrosion. Lag the probe as shown in Fig 8.10 with suitable material.



9 ELECTRICAL CONNECTIONS

9.1 Probe Connections, General



Warning. Before making any connections, ensure that the power supply, any high voltage-operated control circuits and high common mode voltages are switched off.

Carry out the procedures detailed in Sections 9.1.1 and 9.1.2. A 4mm earth bonding point is provided on the back of the probe head – see Fig. 9.2.

9.1.1 Access to Probe Terminals – Fig. 9.1

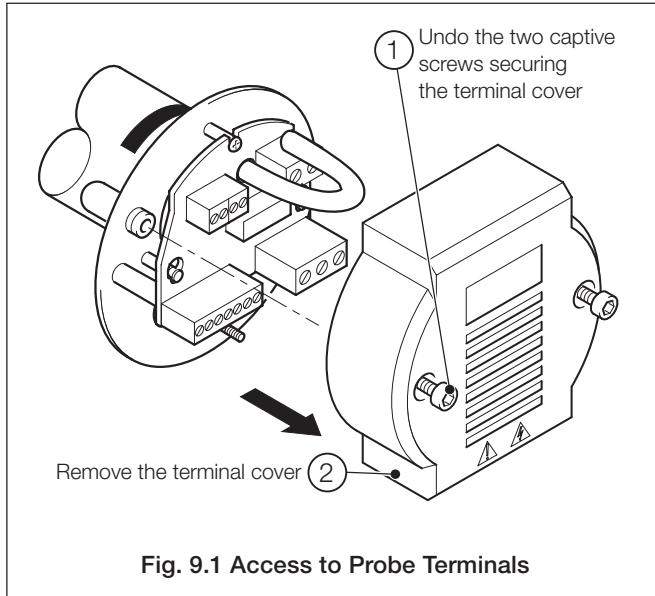

9.1.2 Probe Connections – Fig. 9.2

The probe head accepts two cables for separate routing of signal and power cables, both must be rated to -10 to 80°C (14 to 176°F) and have an outside diameter of between 5 and 9 mm (0.2 to 0.35 in.). The system can be supplied with 10, 25, 50 or 100m of 6-way copper conductor cable for connecting the probe and electronics unit. Power cable is not supplied.

Connect the probe, ensuring the cables are routed as shown in Fig. 9.2

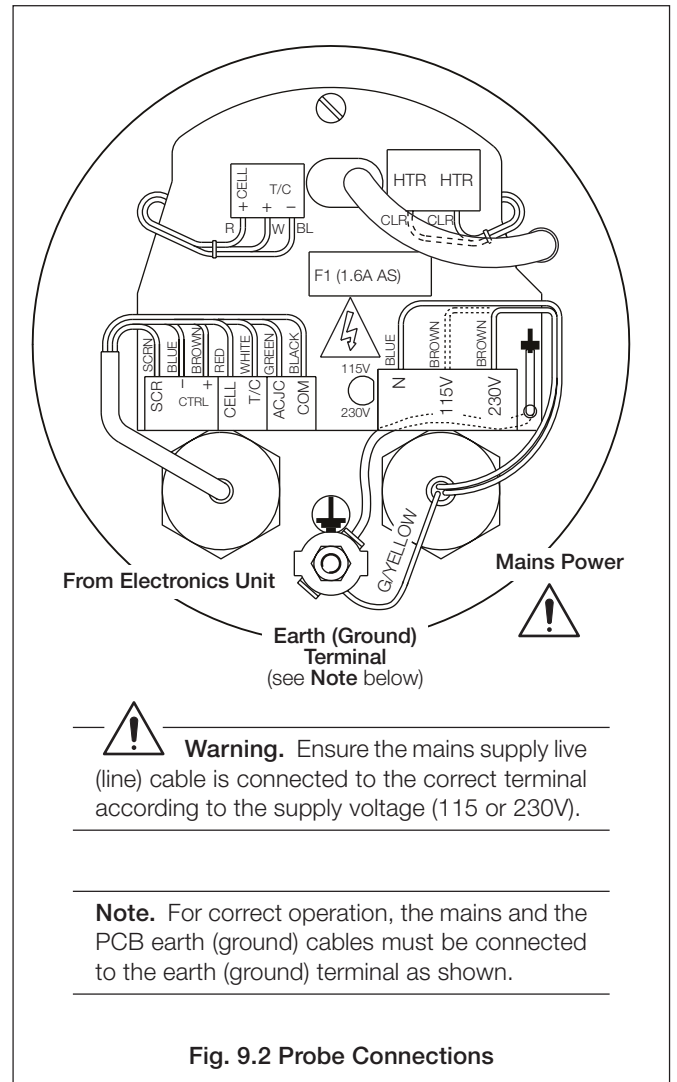

Note. The cable glands supplied with the probe may be replaced by any $\frac{1}{2}$ in. NPT cable entry gland that is certified to 80°C and classed as watertight.

If the glanded entries supplied are changed for any alternative fittings use the 2 packing/sealing rings from the existing glands to ensure correct sealing/alignment.

Warning. Before making any connections, ensure that the power supply, any high voltage-operated control circuits and high common mode voltages are switched off.

9.2 Access to Terminals

9.2.1 Wall-/Pipe-mount Units – Fig. 9.3

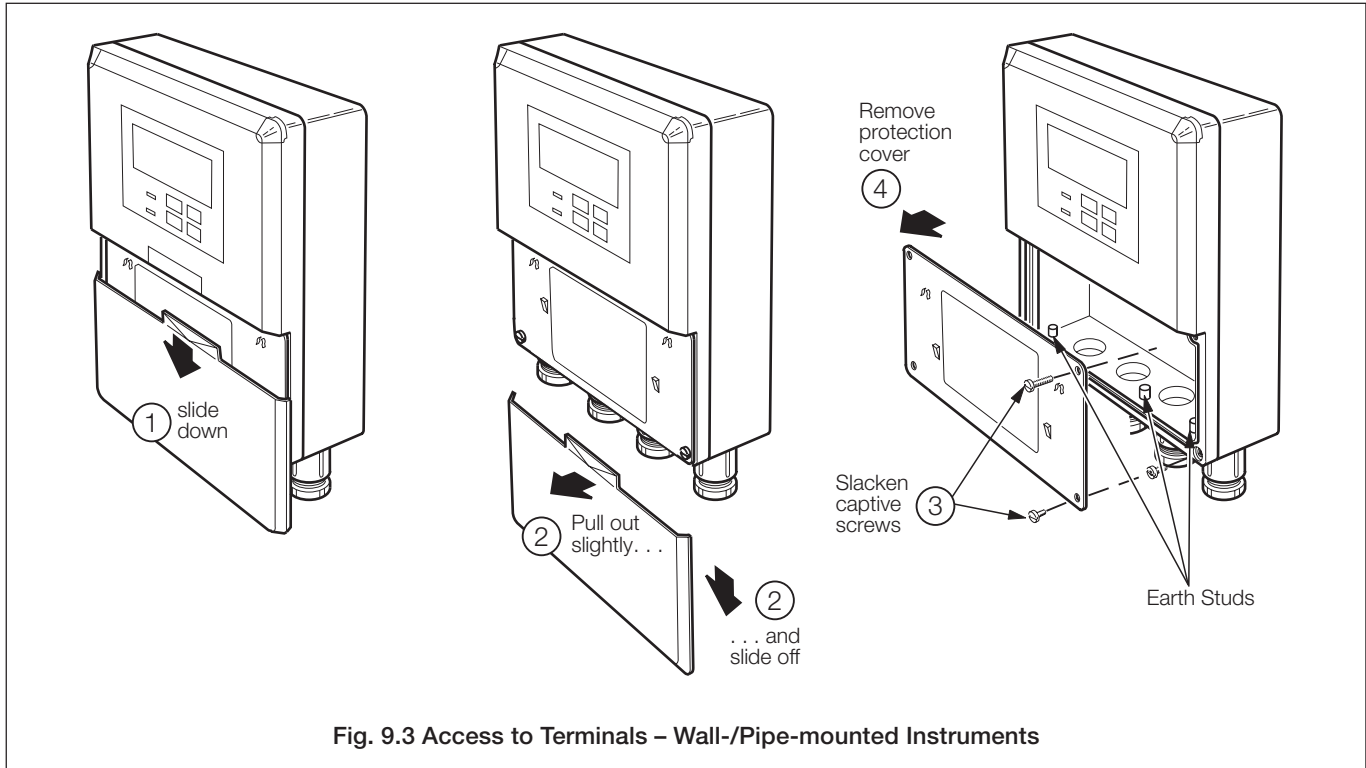

9.2.2 Panel-mount Units – Fig. 9.4

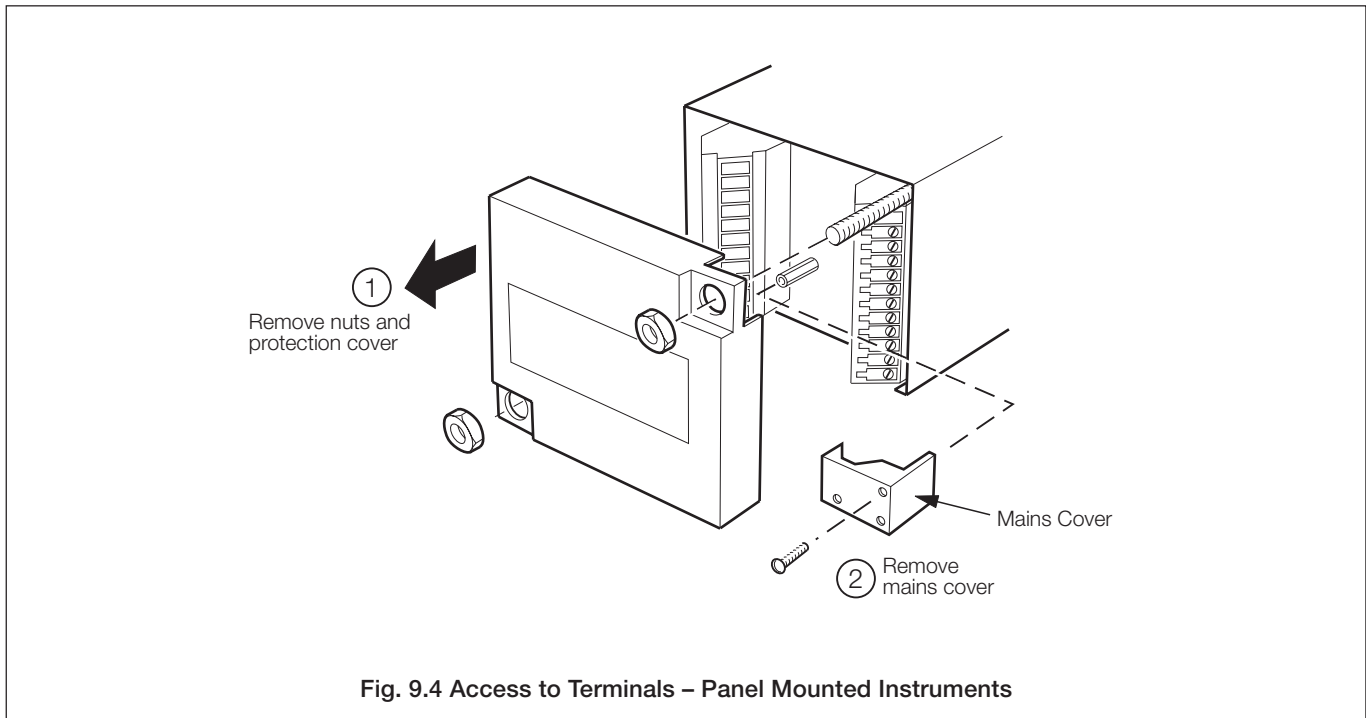

9.3 Selecting the Mains Voltage

9.3.1 Wall-/Pipe-mount Units – Fig. 9.5

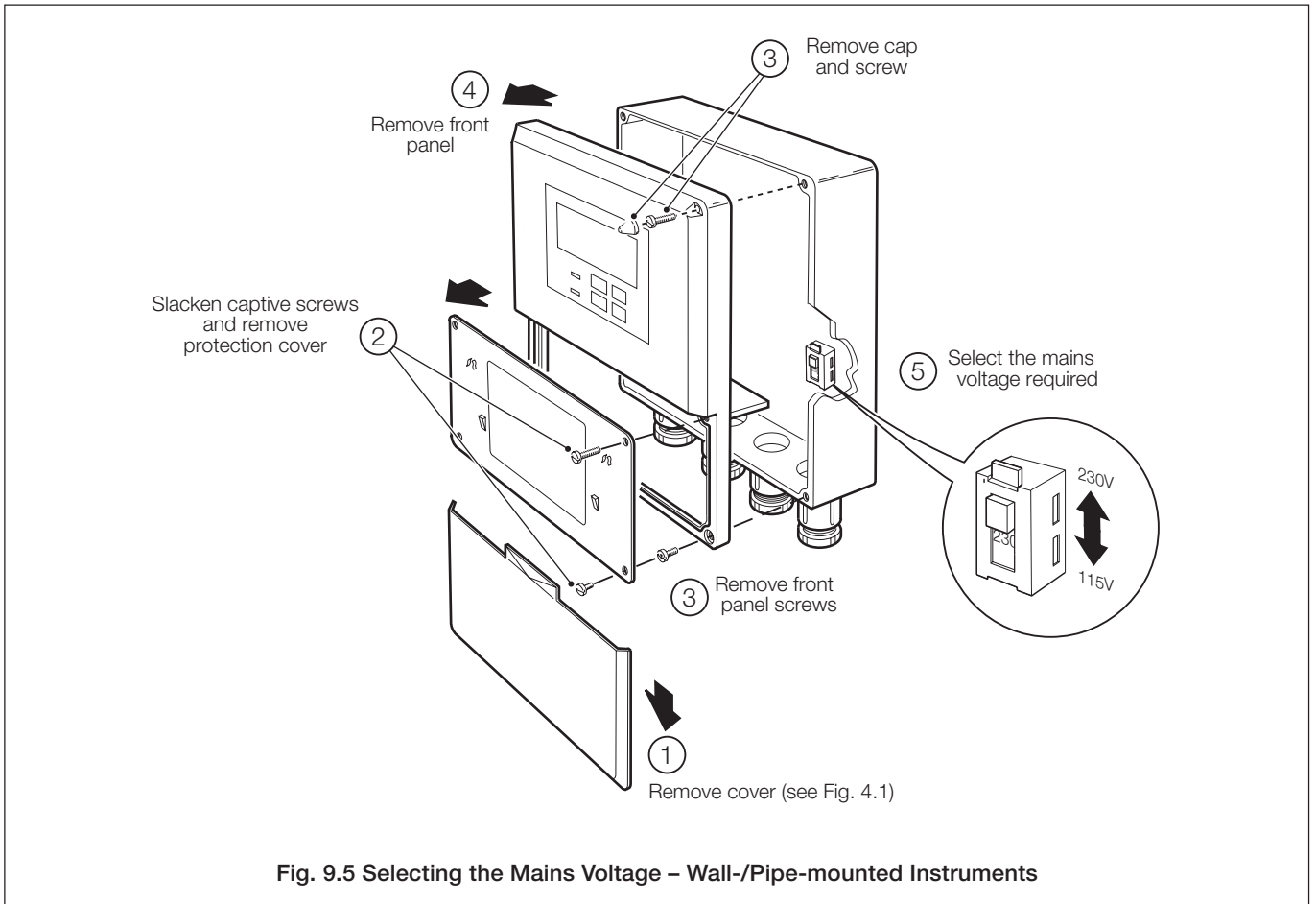

9.3.2 Panel-mount Units – Fig. 9.6

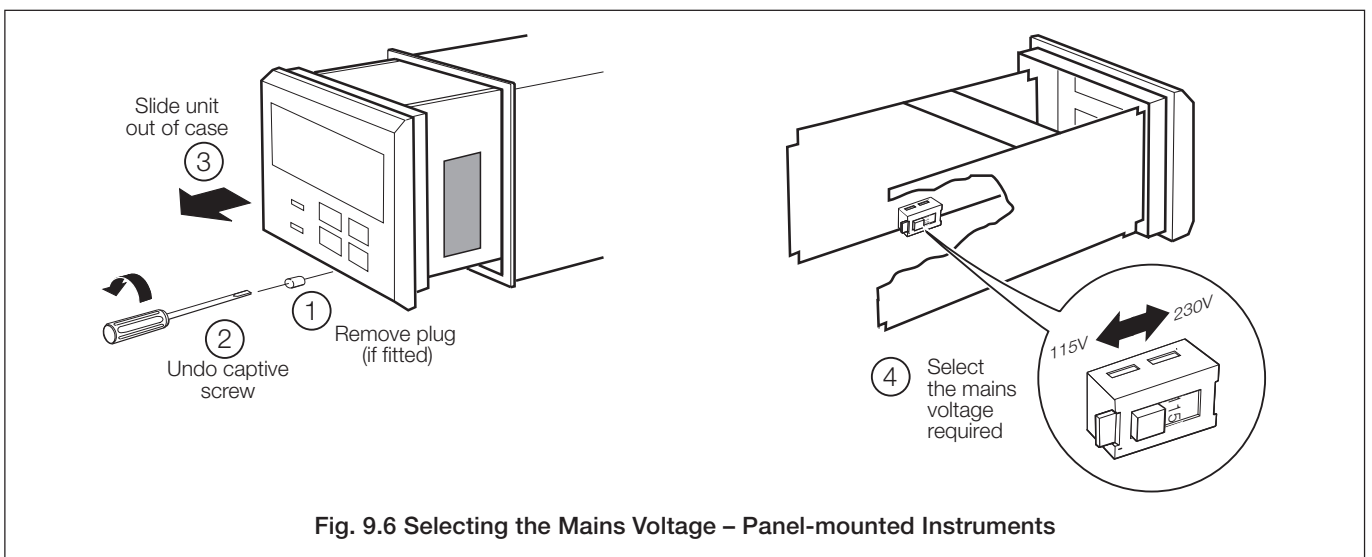

9.4 Connections, General

Notes.

- **Earthing (grounding)** – stud terminal(s) is fitted to the transmitter case for bus-bar earth (ground) connection – see Fig. 9.3 or 9.4.
- **Cable routing** – always route signal output/O₂ probe signal cable and mains-carrying/relay cables separately, ideally in earthed metal conduit. Use twisted pair output leads or use screened cable with the screen connected to the case earth stud.

Ensure that the cables enter the transmitter through the glands nearest the appropriate screw terminals and are short and direct. Do not tuck excess cable into the terminal compartment.
- **Cable glands & conduit fittings** – ensure a moisture-tight fit when using cable glands, conduit fittings and blanking plugs/bungs (M20 holes). The M16 glands ready-fitted to wall-mounted instruments accept cable of between 4 and 7mm diameter.
- **Relays** –the relay contacts are voltage-free and must be appropriately connected in series with the power supply and the alarm/control device which they are to actuate. Ensure that the contact rating is not exceeded. Refer also to Section 9.4.1 (below) for relay contact protection details when the relays are to be used for switching loads.
- **Retransmission output** – Do not exceed the maximum load specification for the selected current retransmission range – see Data Sheet (SS/AZ100).

Since the retransmission output is isolated the –ve terminal must be connected to earth (ground) if connecting to the isolated input of another device.

9.4.1 Relay Contact Protection and Interference Suppression – Fig. 9.7

If the relays are used to switch loads on and off, the relay contacts can become eroded due to arcing. Arcing also generates radio frequency interference (RFI) which can result in instrument malfunctions and incorrect readings. To minimise the effects of RFI, arc suppression components are required; resistor/capacitor networks for AC applications or diodes for DC applications. These components can be connected either across the load or directly across the relay contacts. On 4600 Series instruments the RFI components must be fitted to the relay terminal block along with the supply and load wires – see Fig 9.7.

For **AC applications** the value of the resistor/capacitor network depends on the load current and inductance that is switched. Initially, fit a 100R/0.022µF RC suppressor unit (part no. B9303) as shown in Fig. 9.7A. If the instrument malfunctions (incorrect readings) or resets (display shows **88888**) the value of the RC network is too low for suppression and an alternative value must be used. If the correct value cannot be obtained, contact the manufacturer of the switched device for details on the RC unit required.

For **DC applications** fit a diode as shown in Fig. 9.7B. For general applications use an IN5406 type (600V peak inverse voltage at 3A).

Note. For reliable switching the minimum voltage must be greater than 12V and the minimum current greater than 100mA.

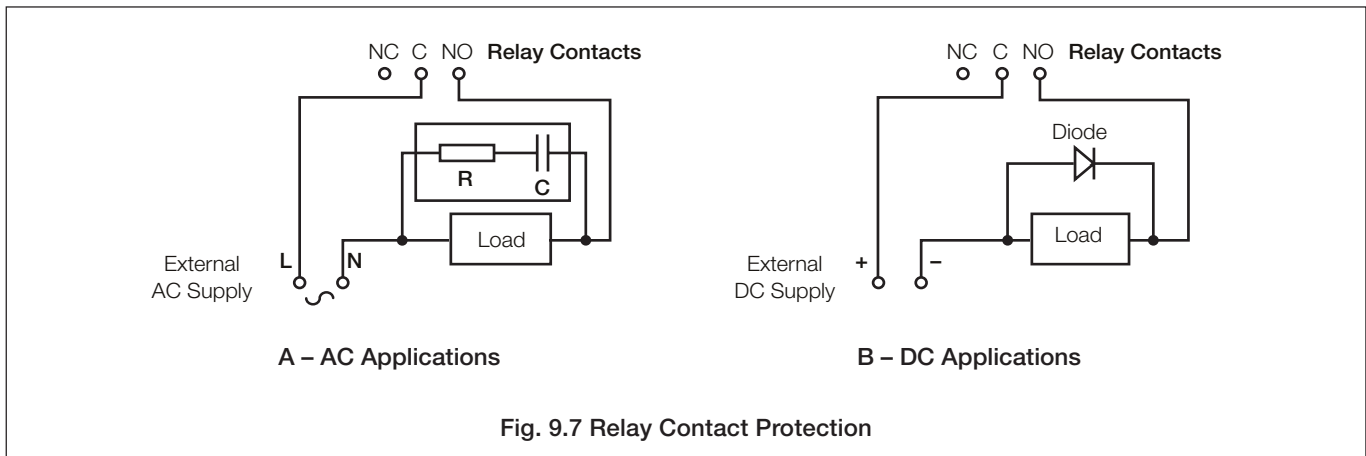

9.5 Connections, Wall-/Pipe-mount Units – Fig. 9.8

Notes.

- Refer to Fig. 9.3 for Access to Terminals.
- Refer to Section 10.3 for power supply cable and Section 10.4 for signal cable specifications.
- Slacken terminal screws fully before making connections.

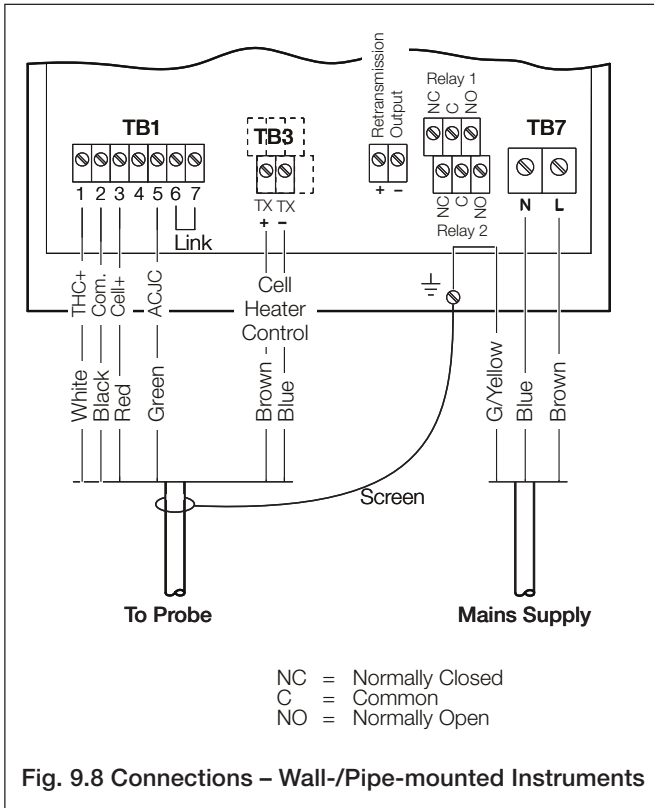

9.6 Connections, Panel-mount Units – Fig. 9.9

Notes.

- Refer to Fig. 9.4 for Access to Terminals.
- Refer to Section 10.3 for power supply cable and Section 10.4 for signal cable specifications.
- Slacken terminal screws fully before making connections.

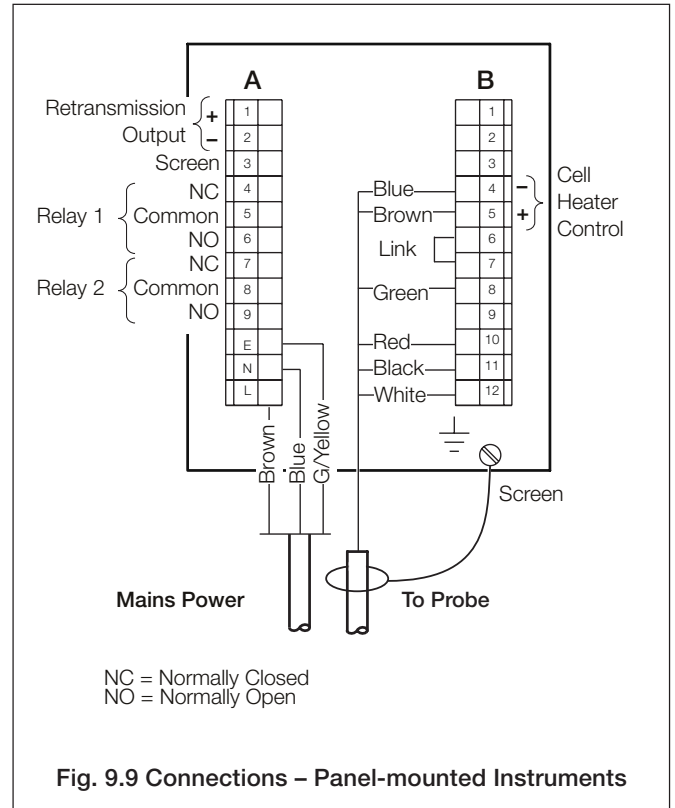

9.7 Connections, Mains Supply Junction Box – Fig. 9.10

The probe and electronics unit **MUST** be connected to a common mains supply – see Fig. 9.10. (Wall-/pipe-mount Electronics Unit shown, panel-mount similar).

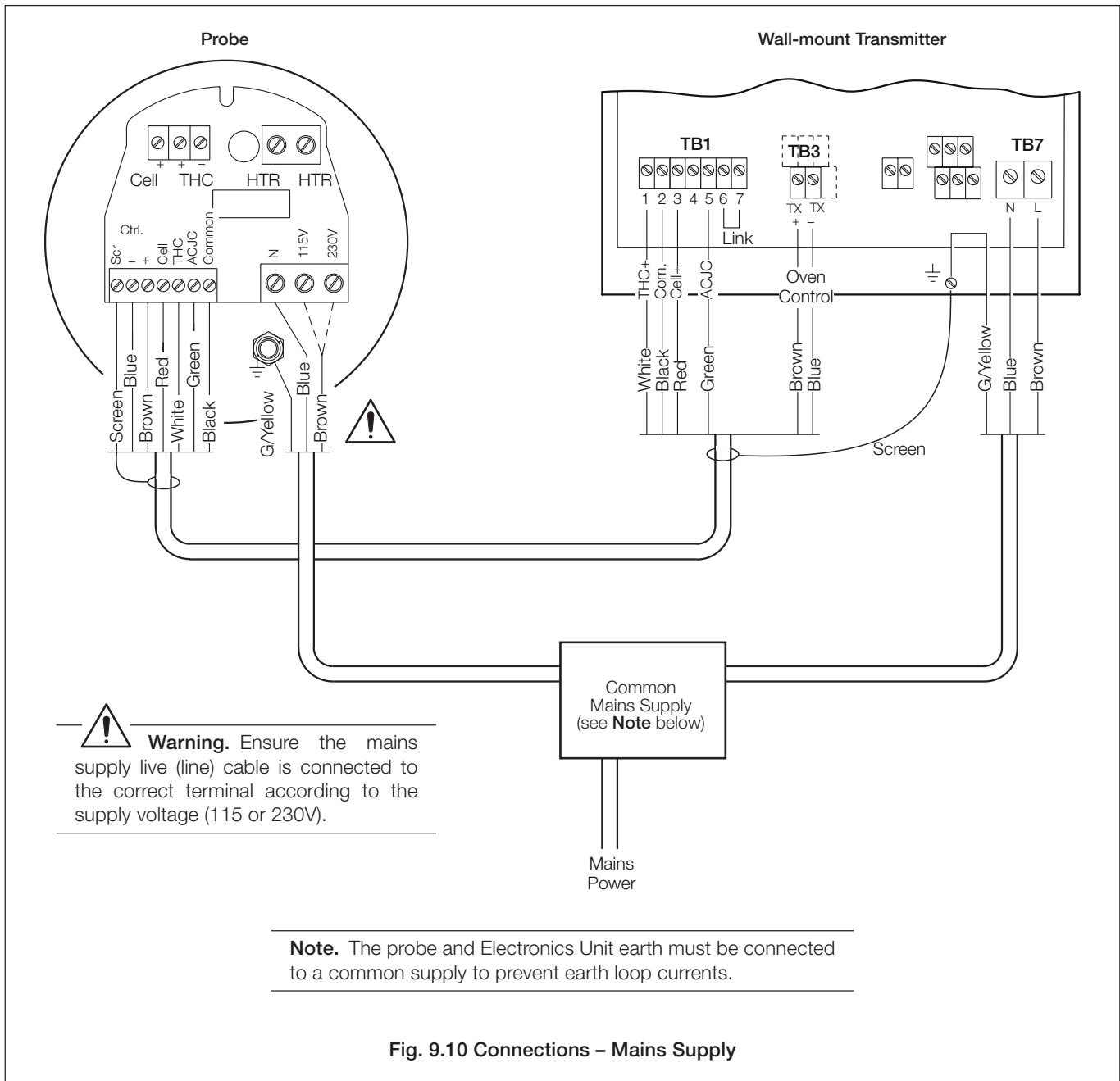

Fig. 9.10 Connections – Mains Supply

NOTES

PRODUCTS & CUSTOMER SUPPORT

Products

Automation Systems

- *for the following industries:*
 - Chemical & Pharmaceutical
 - Food & Beverage
 - Manufacturing
 - Metals and Minerals
 - Oil, Gas & Petrochemical
 - Pulp and Paper

Drives and Motors

- *AC and DC Drives, AC and DC Machines, AC Motors to 1kV*
- *Drive Systems*
- *Force Measurement*
- *Servo Drives*

Controllers & Recorders

- *Single and Multi-loop Controllers*
- *Circular Chart and Strip Chart Recorders*
- *Paperless Recorders*
- *Process Indicators*

Flexible Automation

- *Industrial Robots and Robot Systems*

Flow Measurement

- *Electromagnetic Flowmeters*
- *Mass Flow Meters*
- *Turbine Flowmeters*
- *Flow Elements*

Marine Systems & Turbochargers

- *Electrical Systems*
- *Marine Equipment*
- *Offshore Retrofit and Refurbishment*

Process Analytics

- *Process Gas Analysis*
- *Systems Integration*

Transmitters

- *Pressure*
- *Temperature*
- *Level*
- *Interface Modules*

Valves, Actuators and Positioners

- *Control Valves*
- *Actuators*
- *Positioners*

Water, Gas & Industrial Analytics Instrumentation

- *pH, Conductivity and Dissolved Oxygen Transmitters and Sensors*
- *Ammonia, Nitrate, Phosphate, Silica, Sodium, Chloride, Fluoride, Dissolved Oxygen and Hydrazine Analyzers*
- *Zirconia Oxygen Analyzers, Katharometers, Hydrogen Purity and Purge-gas Monitors, Thermal Conductivity*

Customer Support

We provide a comprehensive after sales service via a Worldwide Service Organization. Contact one of the following offices for details on your nearest Service and Repair Centre.

United Kingdom

ABB Limited
Tel: +44 (0)1453 826661
Fax: +44 (0)1453 829671

United States of America

ABB Inc.
Tel: +1 (0) 775 850 4800
Fax: +1 (0) 775 850 4808

Client Warranty

Prior to installation, the equipment referred to in this manual must be stored in a clean, dry environment, in accordance with the Company's published specification.

Periodic checks must be made on the equipment's condition. In the event of a failure under warranty, the following documentation must be provided as substantiation:

1. A listing evidencing process operation and alarm logs at time of failure.
2. Copies of all storage, installation, operating and maintenance records relating to the alleged faulty unit.

ABB has Sales & Customer Support
expertise in over 100 countries worldwide

www.abb.com

The Company's policy is one of continuous product
improvement and the right is reserved to modify the
information contained herein without notice.

Printed in UK (07.05)

© ABB 2005



ABB Limited
Oldends Lane, Stonehouse
Gloucestershire
GL10 3TA
UK
Tel: +44 (0)1453 826661
Fax: +44 (0)1453 829671

ABB Inc.
Analytical Instruments
9716 S. Virginia St., Ste. E
Reno, Nevada 89521
USA
Tel: +1 (0) 775 850 4800
Fax: +1 (0) 775 850 4808