

WaterMaster Electromagnetic flowmeter

The perfect fit for all water industry applications



The most stable transmitter in the world

- self-calibrating transmitter and ultra-low temperature coefficient for highest accuracy

One solution for all your needs

- designed for use in all water and waste water applications, from sewage plants to distribution networks

Quick transmitter exchange

- revolutionary data storage enables transmitter interchange and commissioning without the need for reconfiguration

Advanced infrared service port

- supports simultaneous and parallel operation of HART, remote HMI, cyclic data output and parameter dump

OIML R49 and MID Approved

- Type approved to OIML R49 to accuracy Class 1 and Class 2, for any pipe orientation and bidirectional flow

Compatible with ABB's full range of industry-leading flow sensors

- reduced-bore FER series for high turn-down applications, for example, leakage detection
- full-bore FEF series for general-purpose water metering applications
- optimized (virtual) full-bore FEV series for optimum turndown / low pressure-drop, irrigation applications
- all sensors are buriable, eliminating the need for costly chamber construction – a significant site preparation saving

OIML R49 permanent self-checking

- Type P approved
- continuous self checking of the sensor and transmitter to ensure the highest accuracy and long term performance

VeriMaster in situ verification software option

- allows the customer to perform in situ verification at the flowmeter

Flexible bus options

- Profibus DP and MODBUS for full system and PLC integration

The Company

We are an established world force in the design and manufacture of instrumentation for industrial process control, flow measurement, gas and liquid analysis and environmental applications. As a part of ABB, a world leader in process automation technology, we offer customers application expertise, service and support worldwide. We are committed to teamwork, high quality manufacturing, advanced technology and unrivalled service and support. The quality, accuracy and performance of the Company's products result from over 100 years experience, combined with a continuous program of innovative design and development to incorporate the latest technology. Over ten flow calibration plants are operated by the Company, which is indicative of our dedication to quality and accuracy.

Introduction

Setting the standard

The WaterMaster range, available in sizes 10 to 2200 mm ($\frac{3}{8}$ to 84 in), is designed specifically for use on the many diverse applications encountered in the Water and Waste-water industry.

WaterMaster is available with a range of sensor geometries from full-bore to reduced bore.

The specification, features and user benefits offered by this range are based on ABB's worldwide experience in this industry and they are all targeted specifically to the industry's requirements.

Flow performance

WaterMaster has an operating flow range with ± 0.4 % accuracy as standard (± 0.2 % optional) in both forward and reverse flow directions.

Submersible and buriable

All WaterMaster sensors have a rugged, robust construction to ensure a long, maintenance-free life under the arduous conditions experienced in the Water and Waste Industry. The sensors are, as standard, inherently submersible (IP68, NEMA 6P), thus ensuring suitability for installation in chambers and metering pits which are liable to flooding.

A unique feature of the WaterMaster sensors is that sizes DN40 to DN2200 are buriable; installation merely involves excavating to the underground pipe, fitting the sensor, cabling back to the transmitter and then backfilling the hole.

Comprehensive features

A wide range of features and user benefits are built into WaterMaster as standard:

- bi-directional flow
- unique, self-calibrating transmitter (patent approval in progress) for the ultimate in stability and repeatability
- OIML-type continuous self-checking, with alarms, ensures both sensor and transmitter accuracy
- true electrode and coil impedance measurement
- comprehensive simulation mode
- universal switch mode power supply (options are available for AC and DC supplies)
- comprehensive self-diagnostics compliant with NAMUR NE107
- programmable multiple alarm capability
- bus options: HART (4 to 20 mA), PROFIBUS (RS485), MODBUS (RS485)
- 3 configurable pulse/frequency and alarm outputs
- advanced infrared service port supports remote HMI, HART, cyclic data out and parameter dump
- VeriMaster in situ verification software available as option
- Read-only switch and ultra-secure service password for total security

Assured quality

WaterMaster is designed and manufactured in accordance with international quality procedures (ISO 9001) and all flowmeters are calibrated on nationally-traceable calibration rigs to provide the end-user with complete assurance of both quality and performance of the meter.



WaterMaster – electromagnetic flowmeter

The perfect fit for all water industry applications

Unrivalled in its scope and applications expertise, ABB offers the world's most comprehensive range of flow measurement products. The FlowMaster family of products is unsurpassed in the number of proven measurement techniques, variety of models and scope of application and includes the WaterMaster range of Electromagnetic Flowmeters.

Getting the best levels of efficiency and performance from your production process requires reliable, accurate instrumentation. WaterMaster provides the flexibility to solve your most demanding water applications enabling previously unattainable operational and financial benefits. WaterMaster is the ultimate solution for flow measurement and management in sectors as diverse as water, wastewater, sewage and effluent.

WaterMaster delivers speed, simplicity and ease of use at every stage of the product's lifecycle. In fact, WaterMaster doesn't just plug the gaps left by competitive products, it is simply the best flow metering solution available today.

Superior control through advanced sensor design

Innovative, patented octagonal sensor design FEV model improves flow profile and reduces up- and down-stream piping requirements for the most commonly used sizes of 40 to 200 mm (1½ to 8 in).



Octagonal bore

WaterMaster sensors are also available in reduced bore geometries, giving the ultimate in low flow performance, with a very high flow turn down range.

The unique design of the reduced-bore sensor conditions the flow profile in the measuring section so that distortions in the flow profile, either upstream or downstream, are flattened. The result is excellent in situ meter performance, even with very bad hydraulic installation conditions.

Using a unique, controlled derivative excitation combined with advanced filtering, WaterMaster improves accuracy by raising zero stability to new levels, resulting in higher accuracy measurements.

Proven in the toughest applications, WaterMaster's rugged, robust and buriable sensors eliminate the need for expensive meter chambers thus providing a long, productive and maintenance-free asset life.

Powerful and flexible transmitter

The backlit, graphical display is rotated easily up to 180 ° (90 ° each way) without any tools, enabling users to position it as best fits their needs. 'Through-the-glass' control allows local operator interface to enable short, quick data entry for all user-specific parameters.



Transmitter display

ABB's universal Human Machine Interface (HMI) simplifies operation, maintenance and training; thereby reducing cost of ownership and providing one common user experience.

All WaterMaster versions utilize an electronics converter module to simplify installation and reduce the number of spare parts. Three variants of the converter module are available: a standard HART protocol variant plus PROFIBUS and MODBUS variants – all enable online modification and monitoring of parameters.

The same transmitter module type (HART, PROFIBUS or MODBUS) is used in both integral and remote installations. The HART converter module features active current and passive pulse outputs while the PROFIBUS and MODBUS modules feature passive pulse outputs.

Intuitive navigation and configuration

The user-friendly interface allows fast and simple data entry for all parameters. 'Easy Setup' guides the operator step-by-step through the menu to set parameters as quickly as possible, thereby simplifying the commissioning phase.

Improved performance through Digital Signal Processing (DSP)

Advanced Digital Signal Processing (DSP) gives improved performance and enables real time measurements for maximum reliability.

DSP enables the transmitter to separate the real signal from the noise, therefore providing high quality outputs especially in harsh environments involving vibration, hydraulic noise and temperature fluctuation.

Self-calibration

A unique self-calibration concept developed by ABB (patent pending) has been implemented in WaterMaster. Compliance with OIML R49 Type P (Permanent) checking requirements requires that electromagnetic flowmeters have 'Checking Facilities', where a simulated signal is fed into the input of the flow transmitter and the output is compared and checked within predetermined limits.

WaterMaster has taken this to the next level and uses this signal to not only check the accuracy, but also to perform automatic calibration. This not only meets and exceeds the OIML R49 requirements, it also means the instrument has the following features:

- self-calibrating instrument
- factory calibration no longer necessary
- calibration adjustment is continuous during normal running
- ultra-stable performance with time
- very low temperature coefficient
- the measurement accuracy depends on one precision resistor only
- adjustment % displayed to user for diagnostic use
- alarm limits to trap hardware failures and out-of-range adjustments

Speed, ease and security in the field

'Fit-and-Flow' data storage inside WaterMaster eliminates the need to match sensor and transmitter in the field. On initial installation, the self-configuration sequence automatically replicates into the transmitter all calibration factors, meter size and serial numbers, as well as customer site-specific settings, eliminating the opportunity for error.

This redundant storage of data in both the sensor and transmitter memory is continually updated during all operations to ensure the integrity of the measurement.

An automatic data self-repair routine corrects any data corruption such as totalizer volume corruption that could occur during a power failure.

Detailed diagnostics for rapid decision making

WaterMaster is proven to be robust and reliable, with unmatched diagnostic capabilities providing the correct information to keep your process up and running. In accordance with NAMUR NE107, alarms and warnings are classified with the status of 'maintenance required', 'check function', 'failure' and 'out of specification'.

The following screen shows an alarm history with the number of occurrences for the alarm together with time durations.

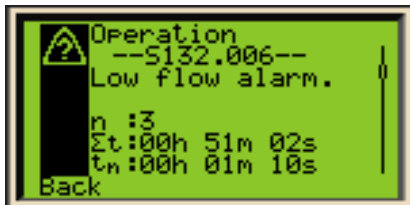

Diagnostics display

Advanced infrared service port

WaterMaster as standard incorporates an infrared service port that enables the meter's configuration to be saved externally.

If a customer alters the configuration and causes the instrument to behave erratically, the infrared service port enables ABB technicians to assist in troubleshooting the problem by allowing easy, remote access to the configuration data.

The infrared service port is used to interrogate HMI menu items automatically and dump the HMI parameter settings and cyclic output measured values (such as flowrate and diagnostic measurement) through the service port to a terminal program. Data can then be downloaded to a PC, saved to a terminal application and output as text or spreadsheet data.



Transmitter with infrared communications device attached

Attention to the smallest technical detail delivers big operational benefits

ABB's WaterMaster sets the standard for flow measurement and management applications in the water, sewage and effluent industries.

Leveraging advanced technology, WaterMaster delivers the power to solve your most demanding applications, enabling previously unattainable operational and financial benefits.

The perfect balance of power, performance, flexibility and control

With WaterMaster, flexible doesn't mean complicated. Take advantage of its innovative and versatile attributes to achieve interoperability within a wide range of asset management systems. WaterMaster, the best solution for your flow measurement needs.

Now the best in class is even better!

In situ verification

WaterMaster is now extended to include VeriMaster for in situ verification. VeriMaster is a PC application, that when coupled to the WaterMaster through the infrared service port, generates a report on the accuracy of the complete flowmeter, both sensor and transmitter. It builds on over 10 years of ABB's experience in the verification field, through its leading CalMaster range. VeriMaster is a quick and easy to use utility, that uses the advanced self-calibration and diagnostic capability of WaterMaster, coupled with fingerprinting technology, to determine the accuracy status of the WaterMaster flowmeter to within +/-1 % of its original factory calibration. VeriMaster also supports printing of calibration verification records for regulatory compliance.

VeriMaster integrates with WaterMaster seamlessly, meaning:

- no interruption to any of the wiring
- no cover removal, with operation through the front glass using the infrared service port
- no interruption to the measurement

If desired, an operator can additionally check and record the accuracy of the current and pulse outputs. VeriMaster is compatible with Microsoft Windows 7 (32-bit), Windows XP and Vista operating systems



The WaterMaster family

OIML / MID approved

WaterMaster has been type tested and Internationally approved through UK National Weights and Measures Laboratory, to the highest accuracy class 1 and 2 for cold and hot potable water meters, known as OIML R49-1 (Organisation Internationale de Métrologie Légale). For full details, OIML R49 is available to download from www.oiml.org. Its requirements are very similar to other International standards, such as the latest revisions of EN14154 and ISO4064. WaterMaster accuracy is better than OIML R49-1 or any of these International standards, with a tighter accuracy specification at the higher flow rates, improving over OIML Class 1 of $\pm 1\%$ to $\pm 0.2\%$ above $Q_{0.2}$, also from Class 2 of $\pm 2\%$ to $\pm 0.4\%$ above $Q_{0.4}$. At lower flowrates, typical WaterMaster accuracies follow the 'trumpet' accuracy curve defined by typically $\pm 0.9\text{ mm} / \text{s}$, again tighter than the OIML accuracy limits.

The OIML R49-1 certificate of conformity is available from:

<http://www.abb.com/product/seitp330/b42ec2377d3293cdc12573de003db93b.aspx>



WaterMaster has been assessed by type approval at the National Measurement Office (NMO) to OIML R49 and passed to the very highest accuracy designations for sizes DN40 to DN200.

The approval is for:

- Class 1 and Class 2 accuracy (calibration option)
- Environmental class T50 for water temperatures of 0.1 °C to 50 °C
- Electromagnetic Environment E2 (10V/m)
- Any pipe orientation
- 5 Diameters upstream pipe
- 0 Diameters downstream pipe
- Pressure Loss Class <0.25 bar
- Integral or remote transmitter (<200 m cable)
- DN40 – DN200, bi-directional flow

A major advance in WaterMaster is the self-checking capabilities which meet and exceed the R49 requirements and is first electromagnetic flowmeter to be approved to OIML Type P permanent self checking during normal operation (not just at startup) and alarm indication for:

- transmitter and sensor status, with an accuracy alarm
- program ROM and RAM status
- double, independent storage of totalizer values, in both the sensor and transmitter non-volatile memories
- display test

WaterMaster is also approved under the EU Measuring Instruments Directive (MID) 2004/22/EC, that covers putting into use water meters for certain applications. MID WaterMaster is secured against tampering and is available as an option, along with fingerprinting for ABB VeriMaster in situ Verification product, with certificate printout to $\pm 1\%$ accuracy. WaterMaster certificates of EC type-examination of a measuring instrument are available from:

<http://www.abb.com/product/seitp330/b42ec2377d3293cdc12573de003db93b.aspx>

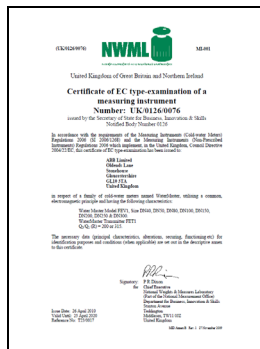

WaterMaster specification to OIML R49 Class 1

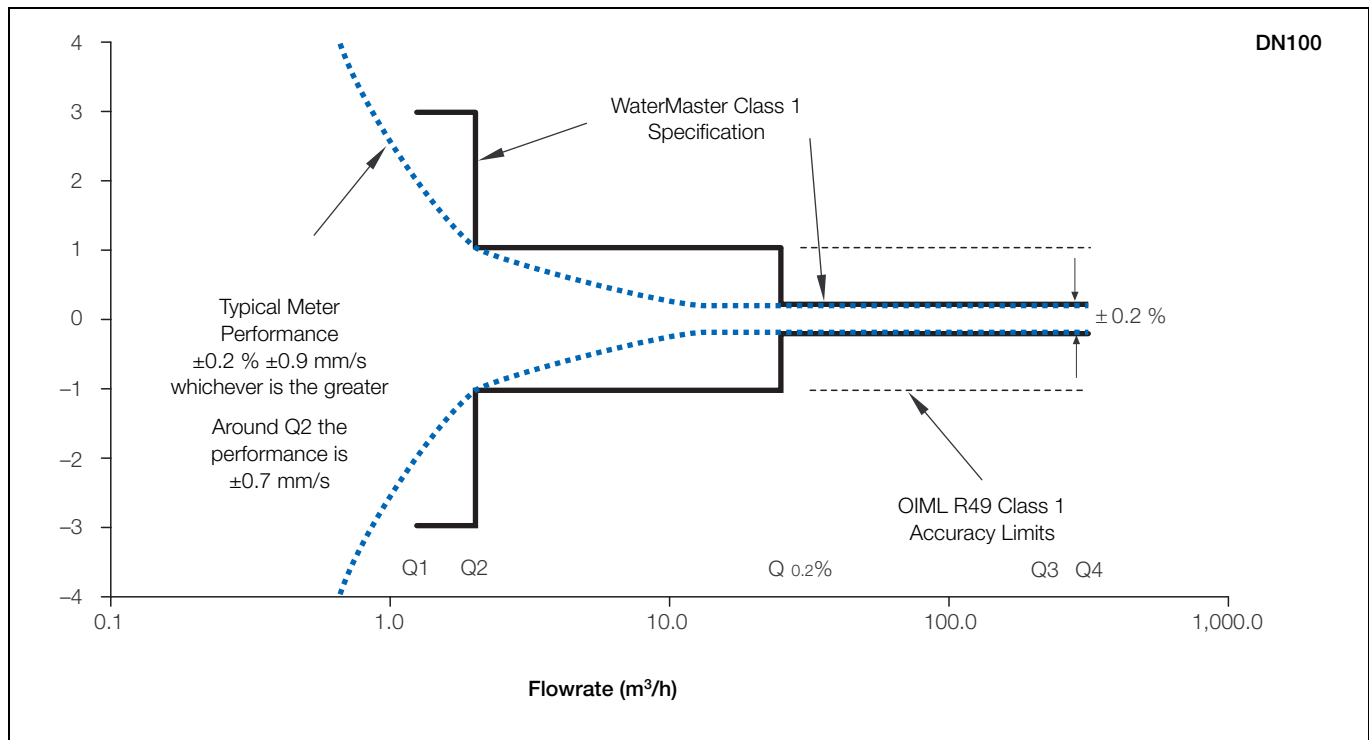

WaterMaster specification to OIML R49 Class 2

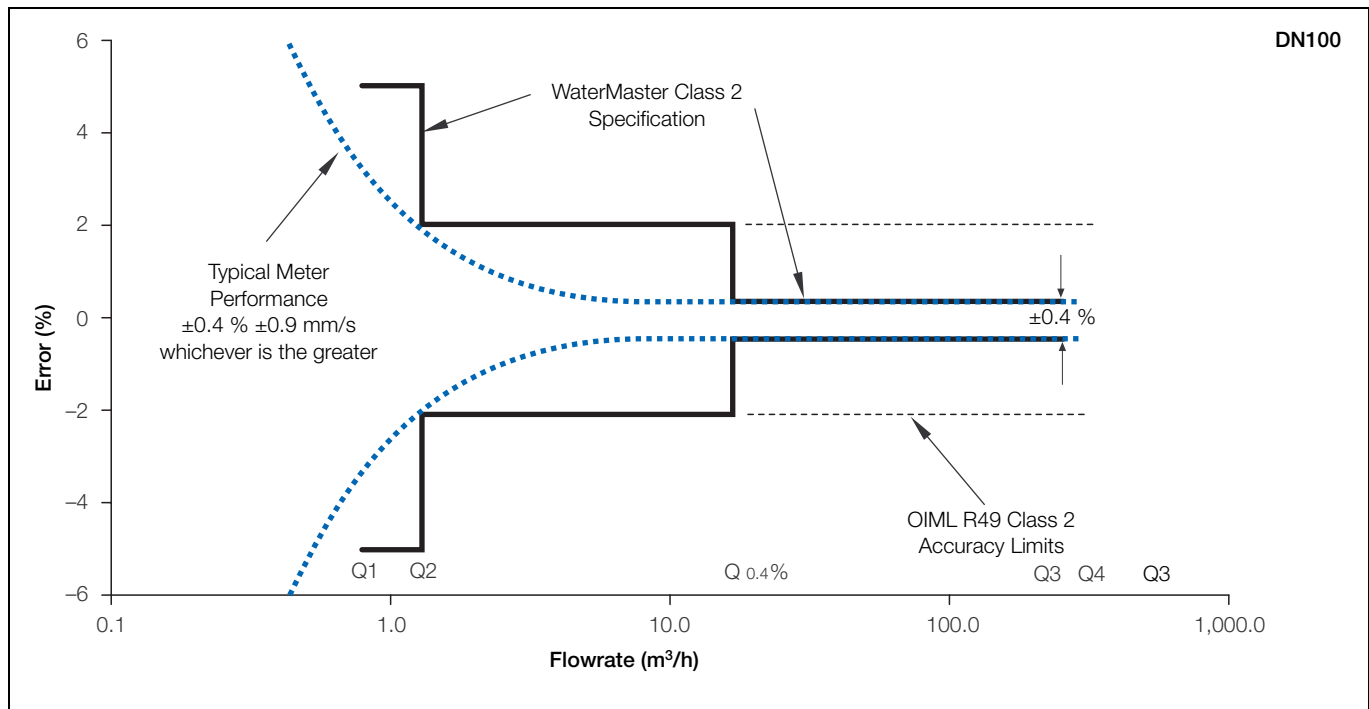

Although OIML R49 does not define the flow accuracy below Q1, WaterMaster continues to measure flow at lower flow rates down to a cutoff velocity of ±5 mm/s (±0.2 in/s). The accuracy between cutoff and Q1 is typically ±0.9 mm/s (±0.04 in/s).

WaterMaster optimized full-bore meter (FEV) / full-bore meters (FEF, FEW) flow performance – m³/h

DN			Standard Calibration 0.4 % Class 2			High Accuracy Calibration 0.2 % Class 1		
	Q4 (m ³ /h)	Q3 (m ³ /h)	Q _{0.4%} (m ³ /h)	Q2 (m ³ /h)	Q1 (m ³ /h)	Q _{0.2%} (m ³ /h)	Q2 (m ³ /h)	Q1 (m ³ /h)
10	3.1	2.5	0.167	0.013	0.008	0.31	0.02	0.012
15	7.88	6.3	0.42	0.032	0.02	0.79	0.05	0.03
20	12.5	10	0.67	0.05	0.032	1.25	0.08	0.05
25	20	16	1.1	0.08	0.05	2	0.13	0.08
32	31.25	25	1.67	0.13	0.08	3	0.20	0.13
40*	50	40	4.2	0.2	0.13	6	0.32	0.2
50*	79	63	4.2	0.32	0.20	7.9	0.5	0.32
65*	125	100	6.7	0.5	0.32	12.5	0.8	0.5
80*	200	160	10.7	0.81	0.51	16	1.3	0.8
100*	313	250	16.7	1.3	0.79	25	2	1.25
125*	313	250	16.7	1.3	0.79	25	2	1.25
150*	788	630	42	3.2	2.0	63	5	3.2
200*	1,250	1,000	67	5.1	3.2	100	8	5
250	2,000	1,600	107	8.1	5.1	160	13	8
300	3,125	2,500	167	12.7	7.9	250	20	12.5
350	5,000	4,000	267	20.3	12.7	400	32	20
400	5,000	4,000	267	20.3	12.7	400	32	20
450	7,875	6,300	420	32	20	630	50	32
500	7,875	6,300	420	32	20	630	50	32
600	12,500	10,000	667	51	32	1000	80	50
700	20,000	16,000	1600	102	64	1600	160	100
30 in	20,000	16,000	1600	102	64	1600	160	100
800	20,000	16,000	1600	102	64	1600	160	100
900	31,250	25,000	2500	160	100	2500	250	156
1000	31,250	25,000	2500	160	100	2500	250	156
42 in	31,250	25,000	2500	160	100	2500	250	156
1200	50,000	40,000	4000	256	160	4000	400	250
1400	78,750	63,000	6300	403	252	6300	630	394
60 in	78,750	63,000	6300	403	252	6300	630	394
1600	78,750	63,000	6300	403	252	6300	630	394
1800	125,000	100,000	10000	640	400	10000	1000	625
2000	125,000	100,000	10000	640	400	10000	1000	625
2200	200,000	160,000	16000	1024	640	16000	1600	1000

* OIML R49 Certificate of Conformance to Class 1 and Class 2, with OIML R49 and MID versions available.

Note. OIML R49–1 allow Class 1 only for meters with Q₃ ≥ 100 m³/h. Meters outside this range have been tested and conform to Class 1.

WaterMaster optimized full-bore meter (FEV) / full-bore meters (FEF, FEW) flow performance – gal/min

NPS/NB (DN)			Standard Calibration 0.4 % Class 2			High Accuracy Calibration 0.2 % Class 1		
	Q4 (gal/min)	Q3 (gal/min)	Q _{0.4%} (gal/min)	Q2 (gal/min)	Q1 (gal/min)	Q _{0.2%} (gal/min)	Q2 (gal/min)	Q1 (gal/min)
3/8 (10)	13.8	11	0.73	0.06	0.035	1.38	0.09	0.053
1/2 (15)	34.7	27.7	1.85	0.14	0.09	3.48	0.22	0.14
3/4 (20)	55	44	2.94	0.22	0.14	5.5	0.35	0.22
1 (25)	88	70.4	4.7	0.35	0.22	8.8	0.57	0.35
1 1/4 (32)	137.6	110	7.3	0.57	0.35	13.2	0.88	0.57
1 1/2 (40)	220	176	18.5	0.89	0.56	26.4	1.41	0.88
2 (50)	347	277	18.5	1.41	0.88	34.7	2.22	1.39
2 1/2 (65)	550	440	29.4	2.24	1.40	55.0	3.52	2.20
3 (80)	881	704	47.0	3.58	2.24	70.4	5.64	3.52
4 (100)	1,376	1,101	73.4	5.59	3.49	110	8.81	5.50
5 (125)	1,376	1,101	73.4	5.59	3.49	110	8.81	5.50
6 (150)	3,467	2,774	185	14.1	8.81	277	22.2	13.9
8 (200)	5,504	4,403	294	22.4	14.0	440	35.2	22.0
10 (250)	8,806	7,045	470	35.8	22.4	704	56.4	35.2
12 (300)	13,759	11,007	734	55.9	34.9	1,101	88.1	55.0
14 (350)	22,014	17,611	1,174	89.5	55.9	1,761	141	88.1
16 (400)	22,014	17,611	1,174	89.5	55.9	1,761	141	88.1
18 (450)	34,673	27,738	1,849	141	88.1	2,774	222	139
20 (500)	34,673	27,738	1,849	141	88.1	2,774	222	139
24 (600)	55,036	44,029	2,935	224	140	4,403	352	220
27/28* (700)	88,057	70,446	7,045	451	282	7,045	704	440
30 (760)	88,057	70,446	7,045	451	282	7,045	704	440
32 (800)	88,057	70,446	7,045	451	282	7,045	704	440
36 (900)	137,590	110,072	11,007	704	440	11,007	1,100	688
39/40* (1000)	137,590	110,072	11,007	704	440	11,007	1,100	688
42 (1050)	137,590	110,072	11,007	704	440	11,007	1,100	688
48 (1200)	220,143	176,115	17,611	1,127	704	17,611	1,761	1,101
54 (1400)	346,726	277,381	27,738	1,775	1,110	27,738	2,773	1,733
60 (1500)	346,726	277,381	27,738	1,775	1,110	27,738	2,773	1,733
66 (1600)	346,726	277,381	27,738	1,775	1,110	27,738	2,773	1,733
72 (1800)	550,358	440,287	44,029	2,818	1,761	44,029	4,403	2,752
78 (2000)	550,358	440,287	44,029	2,818	1,761	44,029	4,403	2,752
84 (2200)	880,573	704,459	70,446	4,509	2,818	70,446	7,045	4,403

*Size is dependent on flange specification

WaterMaster reduced-bore meter (FER) – flow performance

Size		Class 2 specification					Class 1 specification				
mm	in.	Q ₄ m ³ / h (Ugal / min)	Q ₃ m ³ / h (Ugal / min)	Q _{0.4 %} m ³ / h (Ugal / min)	Q ₂ m ³ / h (Ugal / min)	Q ₁ m ³ / h (Ugal / min)	R	Q _{0.2 %} m ³ / h (Ugal / min)	Q ₂ m ³ / h (Ugal / min)	Q ₁ m ³ / h (Ugal / min)	R
40	1½	31 (138)	25 (110)	0.83 (1.05)	0.063 (0.28)	0.04 (0.18)	630	1.7 (7.48)	0.1 (0.44)	0.063 (0.28)	400
50	2	50 (220)	40 (176)	1.0 (4.40)	0.1 (0.44)	0.063 (0.28)	630	2.0 (8.8)	0.16 (0.7)	0.1 (0.44)	400
65	2½	79 (347)	63 (277)	1.6 (7.04)	0.16 (0.7)	0.1 (0.44)	630	3.2 (10.56)	0.25 (1.1)	0.16 (0.7)	400
80	3	125 (550)	100 (440)	2.0 (8.80)	0.25 (1.1)	0.16 (0.7)	630	4.0 (17.6)	0.4 (1.76)	0.25 (1.1)	400
100	4	200 (880)	160 (704)	3.2 (10.56)	0.41 (1.8)	0.25 (1.1)	630	6.4 (28)	0.64 (2.8)	0.4 (1.76)	400
125	5	200 (880)	160 (704)	3.2 (10.56)	0.41 (1.8)	0.25 (1.1)	630	6.4 (28)	0.64 (2.8)	0.4 (1.76)	400
150	6	500 (2200)	400 (1760)	8.0 (35.20)	1.0 (4.4)	0.63 (2.77)	630	16 (70.4)	1.6 (7)	1.0 (4.4)	400
200	8	788 (3470)	630 (2770)	13.0 (57.2)	1.6 (7.04)	1.0 (4.4)	630	25 (110)	2.5 (11)	1.6 (7)	400
250	10	1250 (5500)	1000 (4400)	20 (88)	2.5 (11.01)	1.6 (7)	630	40 (176)	4.0 (17.6)	2.5 (11)	400
300	12	2000 (8810)	1600 (7045)	32 (140.8)	4.1 (18.05)	2.5 (11)	630	64 (281.6)	6.4 (28)	4.0 (17.6)	200
350	14	2000 (8810)	1600 (7045)	32 (140.8)	6.4 (28.18)	4.0 (17.6)	400	64 (281.6)	12.8 (56)	8.0 (35.2)	200
375	15	2000 (8810)	1600 (7045)	32 (140.8)	6.4 (28.18)	4.0 (17.6)	400	64 (281.6)	12.8 (56)	8.0 (35.2)	200
400	16	3125 (13760)	2500 (11007)	50 (220)	10 (44)	6.3 (27.7)	400	100 (440)	20 (88)	12.5 (55)	200
450	18	3125 (13760)	2500 (11007)	50 (220)	10 (44)	6.3 (27.7)	400	100 (440)	20 (88)	12.5 (55)	200
500	20	5000 (22014)	4000 (17610)	80 (352)	16 (70.45)	10 (44)	400	160 (70.4)	32 (141)	20 (88)	200
600	24	7875 (34670)	6300 (27740)	126 (554.4)	25.2 (110.9)	15.8 (70)	400	252 (1108)	50.4 (222)	31.5 (138.7)	200

Specification – sensor

Functional specification

Pressure limitations

As per flange rating – non approved
PN16 for OIML R49, MID Approved

Pressure equipment directive 97/23/EC

This product is applicable in networks for the supply, distribution and discharge of water and associated equipment and is therefore exempt.

Temperature limitations

Ambient temperature
Remote transmitter –20 to 70 °C (–4 to 158 °F)
Integral transmitter –20 to 60 °C (–4 to 140 °F)
Process temperature –6 to 70 °C (21 to 158 °F) – non approved
0.1 to 50 °C (32.2 to 122 °F) – OIML R49 T50 Approved

Environmental protection

Rating:
IP68 (NEMA 6) to 10m (33 ft) depth (not DN10 to DN32)
IP67 (NEMA 4X) – DN10 to DN32

Buriable (sensor only)

FEW (DN10 to 32) No
FEV, FEF, FER and FEW (DN250 to 600) Yes
to 5 m (16 ft.)

Conductivity

>5µS cm⁻¹

Transmitter mounting

Integral (not FEF) or remote

Electrical connections

20 mm glands
1/2 in NPT
20 mm armored glands

Sensor cable

ABB WaterMaster cable available in two forms –
standard and armored
Maximum length 200 m (660 ft)

Physical specification

Wetted parts

Electrode material

Stainless steel 316 L and super-austenitic steel
Hastelloy® C-22 (Hastelloy C4 on DN10 to DN32)
(Other electrode materials available on request)

Potential equalizing rings

Optional (recommended at least 1 for insulated bore upstream and downstream pipes)

Lining material / potable water approvals

Product Code	Size Range	Liner	Potable Water Approvals			
			WRAS	ACS	NSF-61	AZ/NZS 4020
FEV	DN40 – 200	Polypropylene	✓		Approved Meter	✓
FEF	DN250 – 2200	Elastomer	✓	✓	Approved Meter	✓
FEF	DN700 – 2200	Neoprene				
FEF	DN250 – 600	Polyurethane				
FEF	DN250 – 600	Linatex				
FEW	DN10 – 32	PTFE	✓	✓		
FER	DN40 – 600	Elastomer	✓	✓	Pending	✓

Lining protection plates

Not required

Installation conditions (recommended)

Upstream ≥ OD (FER)
Upstream ≥ 5D (FEV, FEF and FEW)
Downstream ≥ OD (FEV, FEF, FER and FEW [DN10 to 32])

Pressure loss

<0.25 bar at Q3 FEV (DN40 to 200 [1¹/₂ to 8 NB])
Negligible at Q3 FEW (DN10 to 32 [3⁸/₈ to 1¹/₄ NB])
FEF, FEW (DN250 to 2200 [10 to 84 NB])
<0.63 bar at Q3 FER (DN40 to 600 [1¹/₂ to 24 NB])

Non-wetted parts

Flange material

Carbon steel (DN20 to DN2200 [3⁴/₄ to 84 NB])
Stainless steel (DN10 to DN15 [3⁸/₈ to 1¹/₂ NB])

Housing material

Carbon steel FEV, FER and FEF (DN40 to 200 [1¹/₂ to 8 NB] and DN700 to 2200 [28 to 84 NB])
Plastic FEF, FER (DN250 to 600 [10 to 24 NB])
Aluminium FEW (DN10 to DN32 [3⁸/₈ to 1¹/₄ NB])

Terminal box material

Polycarbonate

Cable gland material

Plastic or brass

Specification – transmitter

Functional specification

Power supply

Mains	85 to 265 V AC @ <7 VA
Low voltage	24 V AC +10 %/-30 % @ <7 VA
DC	24 V ±30 % @ <0.4 A

Supply voltage fluctuations within the specified range have no effect on accuracy

Digital Outputs (3 off)

- Rating 30 V @ 220 mA, open collector, galvanically isolated
- Maximum output frequency 5250 Hz
- 1 off dedicated to Alarm / Logic, programmable function
- 2 off configurable to either Pulse / Frequency or Alarm/Logic function

Current output – HART FEX100 variant

- 4 to 20 mA or 4 to 12/20 mA, galvanically isolated
- Maximum loop resistance 750 Ω
- HART protocol Version 5.7 (HART registered)
- Signal levels compliant with NAMUR NE 43 (3.8 to 20.5 mA)
- Low alarm 3.6 mA, High alarm 21.8 mA

Additional accuracy

- ±0.1 % of reading
- Temperature coefficient: typically <±20 ppm/°C

RS485 Communications – PROFIBUS FEX100-DP variant

- Registered name: FEX100-DP
- RS485 (9.6kbps to 1.5Mbps), galvanically isolated
- DPV0, DPV1
- PA Profile 3.01
- Standard idents: 9700, 9740, 9741
- FEX100-DP specific ident: 3431
- 3 Concurrent MS2 master connections

RS485 Communications – MODBUS FEX100-MB variant

- MODBUS RTU protocol
- RS485 (9.6kbps to 115.2kbps), galvanically isolated

Electrical connections

- 20 mm glands: 1/2 in NPT, 20 mm armored glands

Temperature limitations

- Ambient temperature -20 to 60 °C (-4 to 140 °F)
- Temperature coefficient Typically <±10 ppm/°C @ Vel ≥0.5 m/s

Environmental protection

- Humidity: 0 to 100 %
- Rating: IP67 (NEMA 4X) to 1m (3.3 ft) depth

Tamper-proof security

- Write access prevented by internal switch combined with external security seals for MID applications

Languages

- English, French, German, Italian, Spanish, Polish

Infrared service port

- USB adapter (accessory), USB 1.1. and 2.0 compatible
- Driver software for Windows 2000, XP, 7 (32-bit) and Vista

Housing material

- Powder-coated aluminium with glass window

Hazardous approvals (HART variant only)

- FM & FMc Class 1 Div 2
 - (FM listing NI / 1 / 2 / ABCD / T4, S / II, III / 2 / FG / T4, Ta=60C; Type 4X, IP67 – for transmitter and integral mounting Ta=70C, Type 6P, IP68 – for remote sensor type, IP67 on DN10 to 32)
 - (FMc listing NI / 1 / 2 / ABCD / T4, DIP / II, III / 2 / FG / T4, Ta=60C; Type 4X, IP67 – for transmitter and integral mounting Ta=70C, Type 6P, IP68 – for remote sensor type, IP67 on DN10 to 32)
- FET, FEV, FEW and FEF DN700 to 2200 (27/28* to 84) only
- *Size is dependent on flange specification

Declaration of Conformance

- Copies of CE and PED certification will be available on request.
- WaterMaster has OIML R49 Certificate of Conformity to accuracy class 1 and 2 (FEV DN40 to 200). Copies of accuracy certification are available on request.
- WaterMaster (FEV DN40 to 200) has been type examined under directive MID 2004/22/EC, Annex MI-001. Copies of this certificate are available on request.

Sensor dimensions

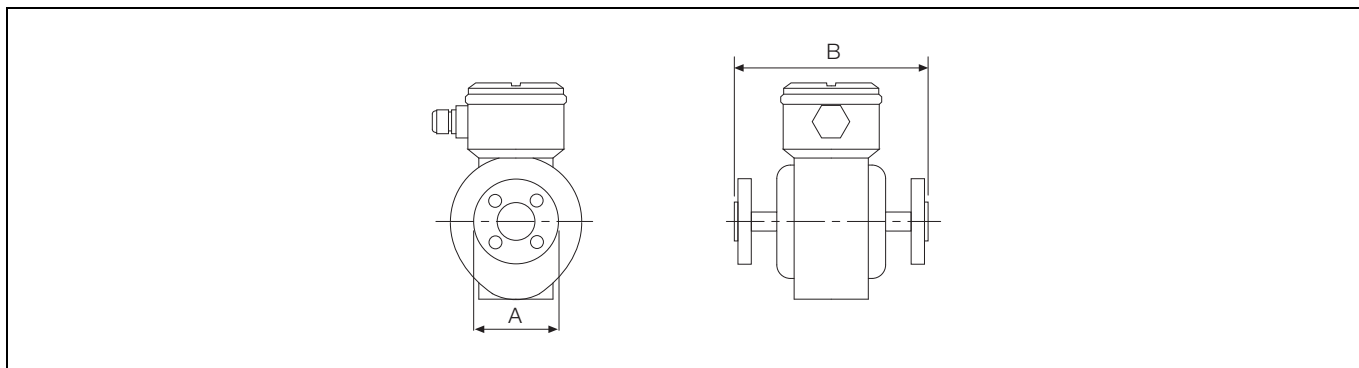

DN10 to 32 ($\frac{3}{8}$ to $1\frac{1}{4}$ NB) full-bore (FEW)

Meter Size		Dimensions mm (in)		Approximate Weight	
DN	NPS/NB	A*	B	kg	lb
10	$\frac{3}{8}$	93 (3.7)	200 (7.9)	6	13.2
15	$\frac{1}{2}$	95 (3.7)	200 (7.9)	7	15.4
20	$\frac{3}{4}$	111 (4.4)	200 (7.9)	7	15.4
25	1	120 (4.7)	200 (7.9)	8	17.6
32	$1\frac{1}{4}$	137 (5.4)	200 (7.9)	10	22

*Dimensions are approximate and vary depending on flange type

DN10 to 32 ($\frac{3}{8}$ to $1\frac{1}{4}$ NB) full-bore (FEW)

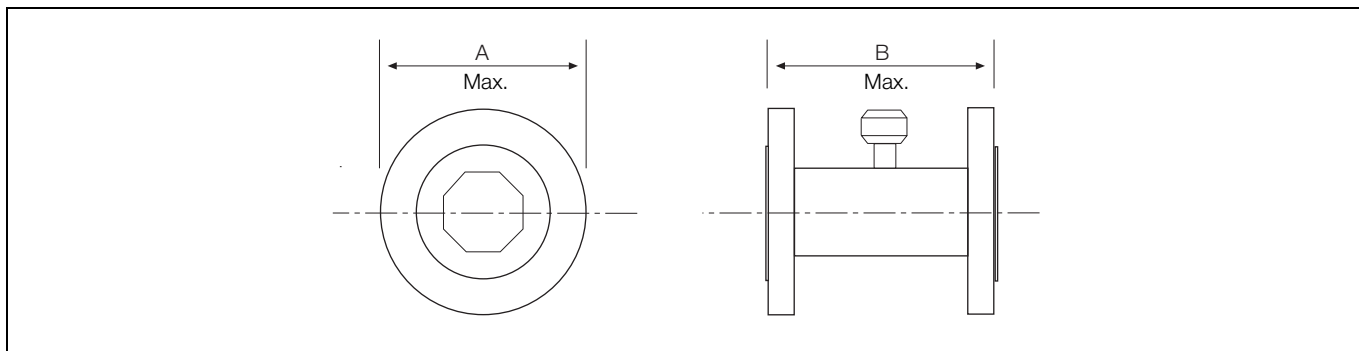

DN40 to 200 ($1\frac{1}{2}$ to 8 NB) full-bore (FEV)

Meter Size		Dimensions mm (in)		Approximate Weight	
DN	NPS/NB	A*	B	kg	lb
40	$1\frac{1}{2}$	150 (5.9)	200 (7.9)	11	24
50	2	165 (6.5)	200 (7.9)	12	27
65	2.5	185 (7.2)	200 (7.9)	14	31
80	3	200 (7.9)	200 (7.9)	15	33
100	4	230 (9.1)	250 (9.8)	18	40
150	6	280 (11.0)	300 (11.8)	31	68
200	8	345 (13.6)	350 (13.8)	48	106

*Dimensions are approximate and vary depending on flange type

DN40 to 200 ($1\frac{1}{2}$ to 8 NB) full-bore (FEV)

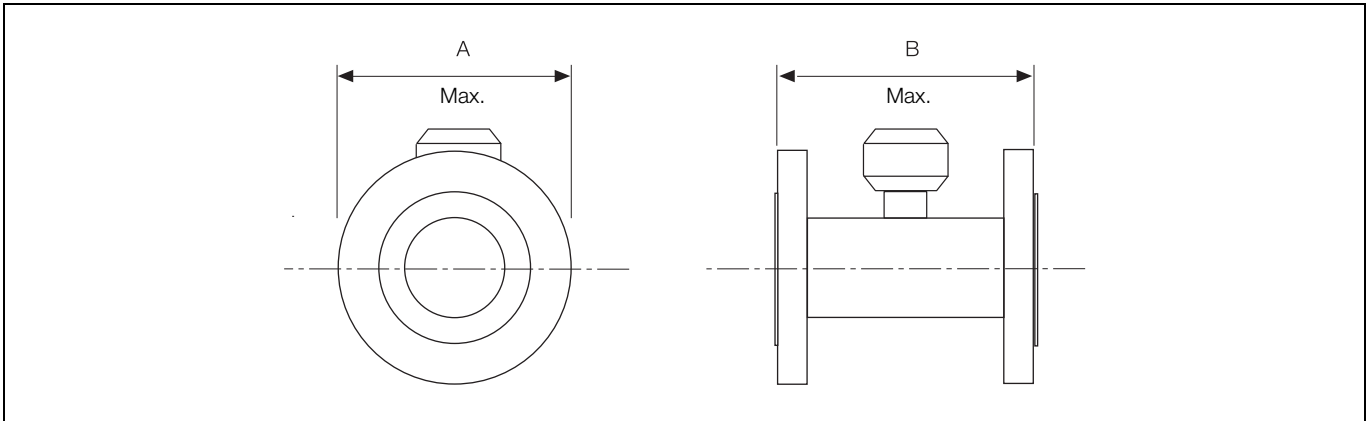

DN40 to 300 (1½ to 12 NB) reduced-bore flanged (FER)

Meter Size		Dimensions mm (in.)		Approx. Weight	
mm	in.	A	B	kg	lb
40	1½	150 (5.9)	200 (7.9)	11	24
50	2	165 (6.5)	200 (7.9)	12	27
65	2½	219 (8.6)	200 (7.9)	13	29
80	3	200 (7.9)	200 (7.9)	18	40
100	4	220 (8.6)	250 (9.8)	25	55
125	4	220 (8.6)	250 (9.8)	25	55
150	6	285 (11.2)	300 (11.8)	31	68
200	8	340 (13.3)	350 (13.8)	48	106
250	10	405 (15.9)	450 (17.7)	75	165
300	12	460 (18.1)	500 (19.7)	112	247

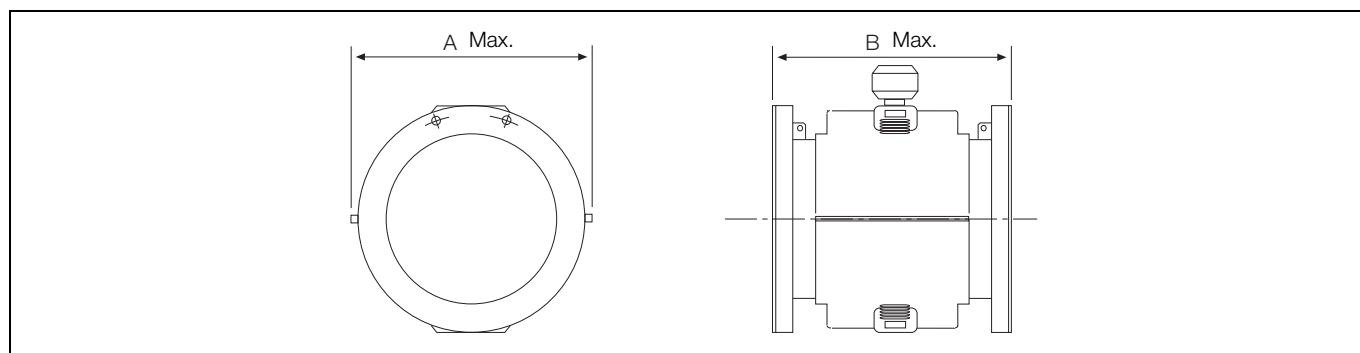

DN250 to 600 (10 to 24 NB) full-bore (FEF)

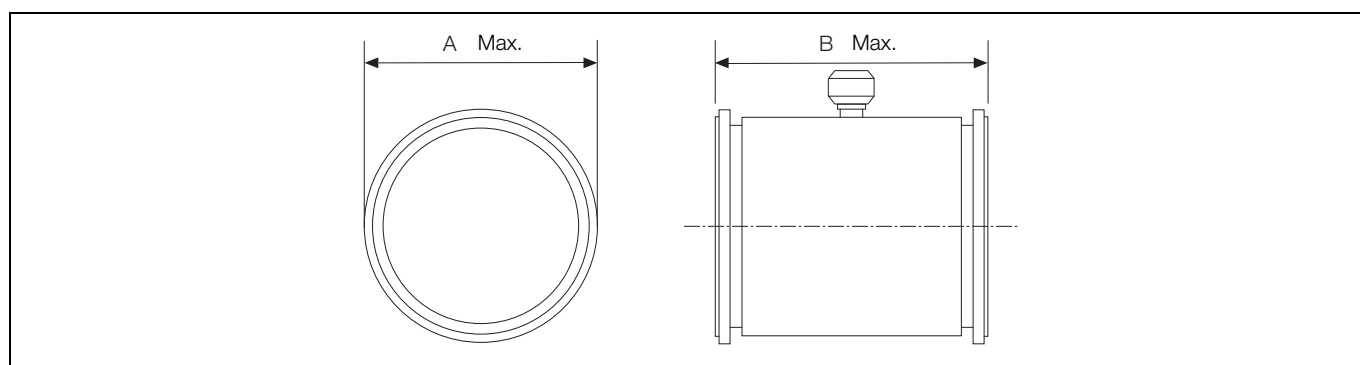

DN700 to 2200 (28 to 84 NB) full-bore (FEF)

Meter Size		Dimensions in mm (in)			Approximate Weight	
DN	NPS/NB	A	B (<PN25)	B (PN25, PN40, ASME, CL300)	kg	lb
250	10	405 (15.9)	450 (17.7)**	488 (19.2)	88	194
300	12	460 (18.1)	500 (19.7)**	538 (21.2)	128	282
350	14	535 (21.1)	550 (21.7)**	568 (22.3)	100	220
400	16	600 (23.6)	600 (23.6)**	618 (24.3)	115	253
450	18	640 (25.2)	698 (27.5)**	698 (27.5)	160	352
500	20	715 (28.1)	768 (30.2)**	768 (30.2)	217	455
600	24	840 (33.1)	918 (36.1)**	918 (36.1)	315	693
700	27/28*	927 (36.5)	700 (27.6)***	-	430	945
760	30	985 (38.8)	762 (30)***	-	430	945
800	32	1060 (41.7)	800 (31.5)***	-	430	945
900	36	1170 (46.1)	900 (35.4)***	-	540	1190
1000	39/40*	1290 (50.8)	1000 (39.4)***	-	720	1585
1050	42	1405 (55.3)	1067 (42)***	-	880	1930
1100	44	1405 (55.3)	1067 (42)***	-	880	1930
1200	48	1511 (59.5)	1200 (47.2)***	-	1000	2160
1400	54	1745 (68.7)	1400 (55.1)***	-	1450	3190
1500	60	1855 (73.0)	1524 (59)***	-	1370	3000
1600	66	2032 (80.0)	1600 (63)***	-	2000	4400
1800	72	2197 (86.5)	2250 (88.6)***	-	2400	5280
2000	78	2362 (93.0)	2500 (98.4)***	-	3200	7040
2200	84	2534 (100.0)	2750 (110)***	-	4200	9300

* Size is dependent on flange specification

Typical tolerances:

** +0/-10 mm (0.40 in)

*** +0/-20 mm (1.0 in)

DN250 to 2200 (10 to 84 NB) full-bore (FEF)

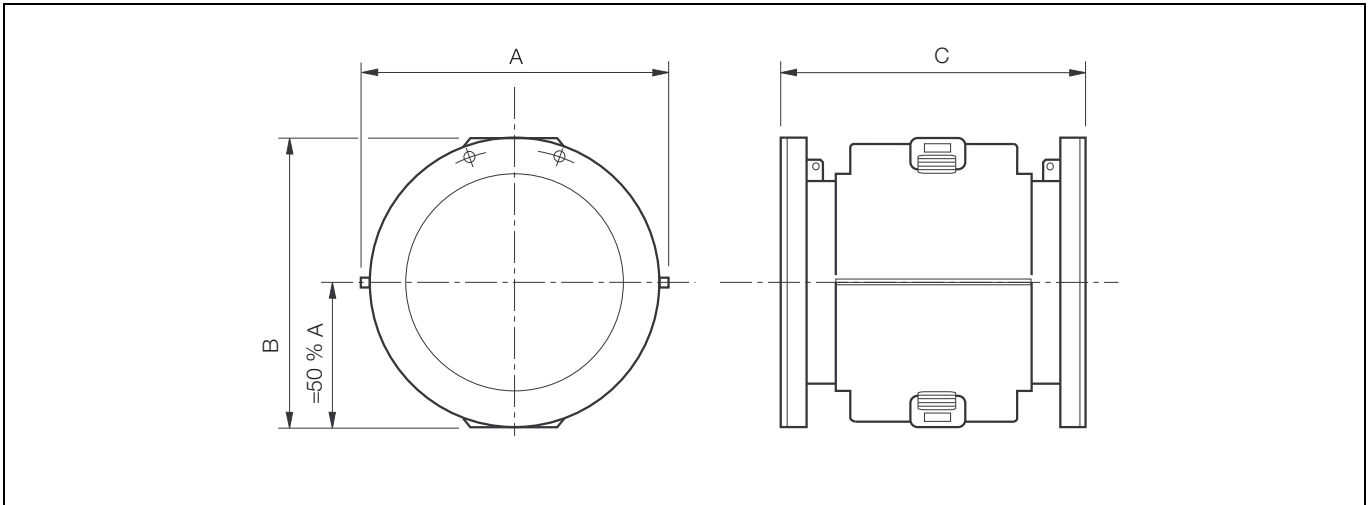

DN350 to 600 (14 to 24 NB) reduced-bore flanged (FER)

Meter Size		Dimensions mm (in.)			Approx. Weight	
mm	in.	A	B	C	kg	lb
350	14	513 (20.2)	520 (20.5)	550 (21.7)	100	220
375	15	550 (21.7)	520 (20.5)	550 (21.7)	105	231
400	16	570 (22.4)	576 (22.7)	600 (23.6)	115	253
450	18	632 (24.9)	627 (24.7)	698 (27.5)	160	352
500	20	686 (27.0)	679 (26.7)	768 (30.2)	217	455
600	24	772 (30.4)	770 (30.3)	918 (36.1)	315	693

Transmitter dimensions

Integral transmitter

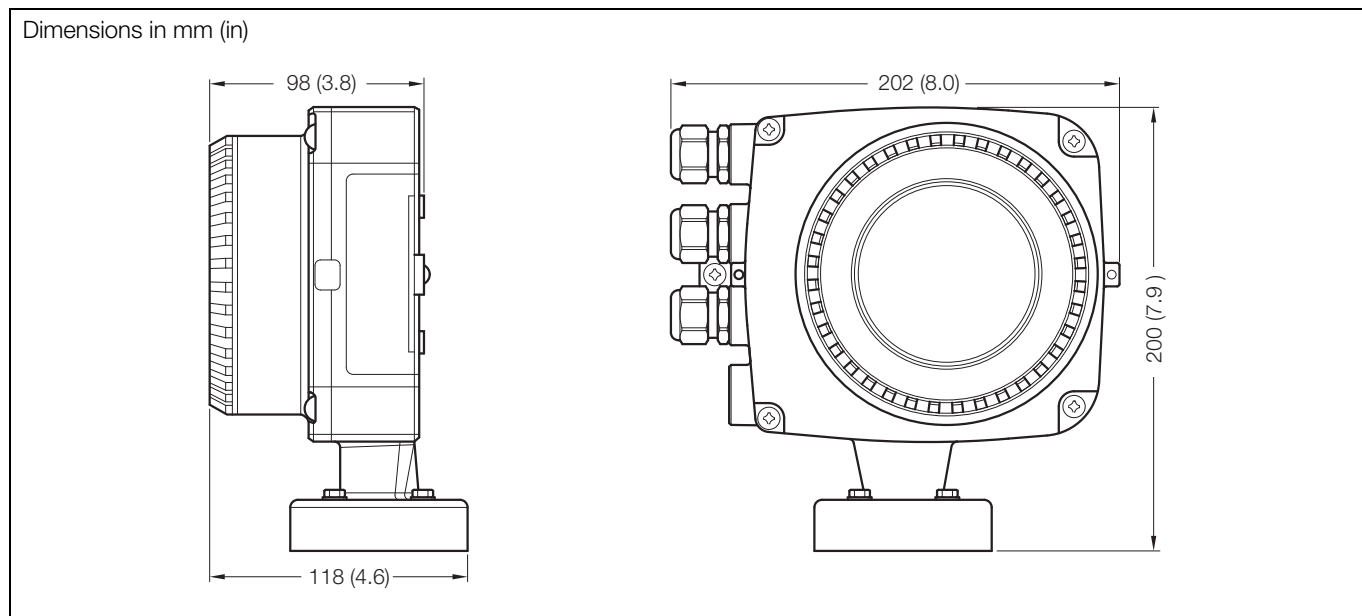

Remote transmitter

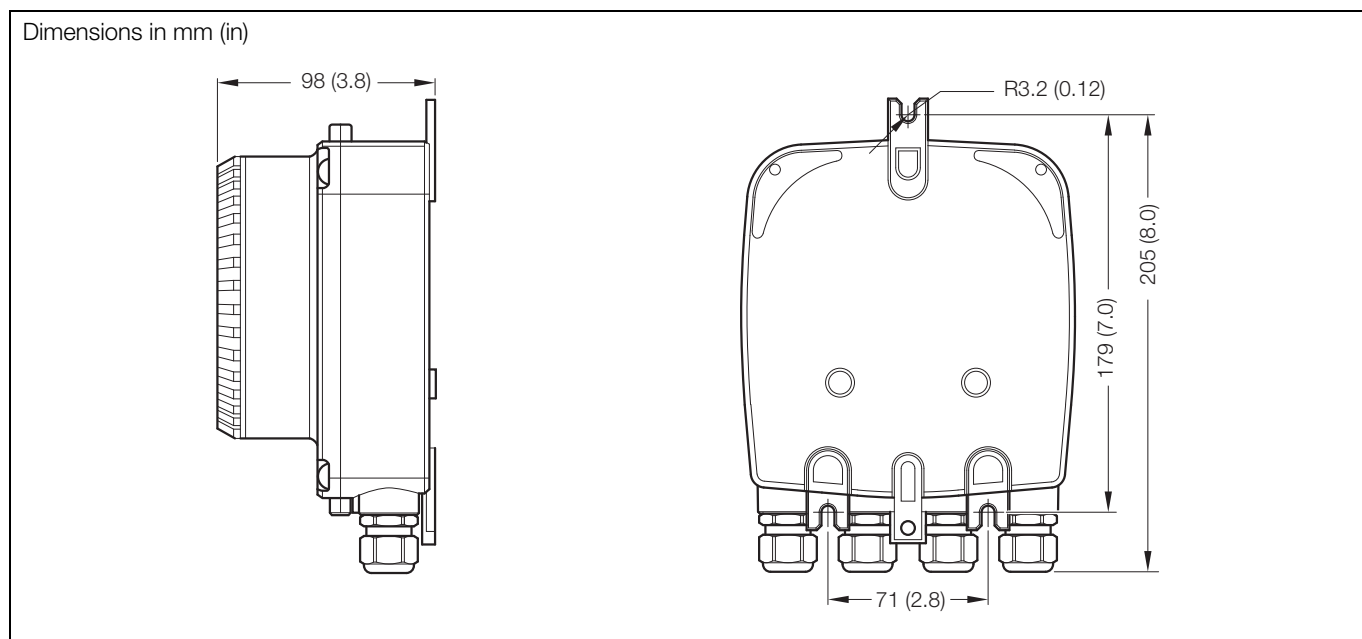

Electrical connections

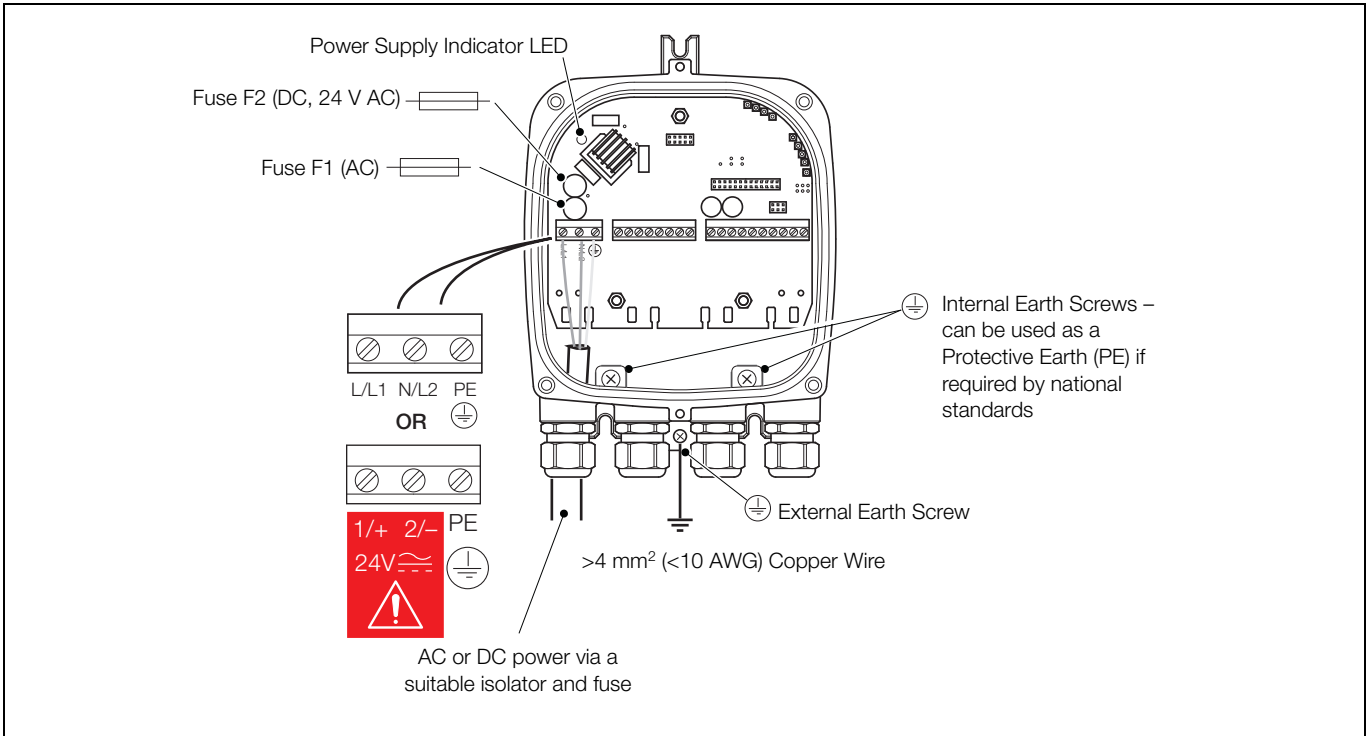

AC and DC power supply connections

Ordering information

Electromagnetic flowmeter WaterMaster FEF12 and FEF18

Variant digit number	1 ... 5	6	7 ... 9	10	11	12	13	14, 15	16	17	18	19	20	21	22	23	24	25	26	27	Options
Flowmeter system, full bore, remote mount	FEF12		XXX	X	X	X	X	XX	X	X	X	X	X	X	X	X	X	X	X	X	
Full bore sensor only, for use with WaterMaster transmitter / remote	FEF18																				
Design																					
Non-hazardous areas		1																			
Hazardous areas (DN≥700)		5																			
Bore diameter																					
DN250 (10 in)		250																			
DN300 (12 in)		300																			
DN350 (14 in)		350																			
DN375 (15 in)		375																			
DN400 (16 in)		400																			
DN450 (18 in)		450																			
DN500 (20 in)		500																			
DN600 (24 in)		600																			
DN700 (28 in)		700																			
30 in		760																			
DN800 (32 in)		800																			
DN900 (36 in)		900																			
DN1000 (40 in)		001																			
42 in		051																			
DN1200 (48 in)		201																			
DN1400 (54 in)		401																			
60 in		501																			
DN1600 (66 in)		601																			
DN1800 (72 in)		801																			
DN2000 (78 in)		002																			
DN2200 (84 in)		202																			
Others		999																			
Liner material																					
Elastomer			K																		
Neoprene (DN700 to DN2200 only)			C																		
Linatex (DN250 to DN600 only)			J																		
Polyurethane (DN250 to DN600 only)			U																		
Electrode design																					
Standard			1																		
Others			9																		
Measuring electrodes material																					
Stainless steel 316			S																		
Hastelloy® C-22			C																		
Super-austenitic steel (DN250 to 600)			U																		
Others			Z																		
Grounding accessories																					
Standard			1																		
One potential equalizing ring (stainless steel)			3																		
Two potential equalizing rings (stainless steel)			4																		
Others			9																		

Continued on page 21

Variant digit number	1 ... 5	6	7 ... 9	10	11	12	13	14, 15	16	17	18	19	20	21	22	23	24	25	26	27	Options
Flowmeter system, full bore, remote mount	FEF12		XXX	X	X	X	X	XX	X	X	X	X	X	X	X	X	X	X	X	X	
Full bore sensor only, for use with WaterMaster transmitter / remote	FEF18																				
Process connection type																					
Flanges ASME B16.5 class 150									A1												
Flanges ASME B16.5 class 300									A3												
Flanges AWWA C207 class B									C1												
Flanges AWWA C207 class D									C2												
Flanges AS 4087 PN21									E0												
Flanges AS 4087 PN16									E1												
Flanges AS 4087 PN14									E2												
Flanges AS 2129 Table F									E3												
Flanges AS 2129 Table E									E4												
Flanges AS 2129 Table D									E5												
Flanges AS 2129 Table C									E6												
Flanges AS 2129 Table H									E7												
Flanges AS 4087 PN35									E8												
Flanges JIS G5527 7.5K									J0												
Flanges JIS B2220 10K									J1												
Flanges JIS B2220 5K									J2												
Flanges ISO / EN PN6									S0												
Flanges ISO / EN PN10									S1												
Flanges ISO / EN PN16									S2												
Flanges ISO / EN PN25									S3												
Flanges ISO / EN PN40									S4												
Others									Z9												
Process connection material																					
Carbon steel flanges									B												
Others									Z												
Usage certifications																					
Standard										1											
Calibration type																					
Class 2 Calibration – standard accuracy 0.4 %										A											
Class 1 Calibration – enhanced accuracy 0.2 %										B											
Extended range, class 2 calibration – standard accuracy 0.4 %										N											
Extended range, class 1 calibration – enhanced accuracy 0.2 %										P											
Temperature range installation / ambient temperature range																					
Standard design / –20 ... 60 °C (–4 ... 140 °F)										1											
Nameplate																					
Adhesive										A											

Continued on page 22

Variant digit number	1 ... 5	6	7 ... 9	10	11	12	13	14, 15	16	17	18	19	20	21	22	23	24	25	26	27	Options	
Flowmeter system, full bore, remote mount	FEF12																					
Full bore sensor only, for use with WaterMaster transmitter / remote	FEF18		XXX	X	X	X	X	XX	X	X	X	X	X	X	X	X	X	X	X	X		
Signal cable length and type*																						
Without signal cable																						0
5 m (15 ft.) cable																						1
10 m (30 ft.) cable																						2
20 m (60 ft.) cable																						3
30 m (100 ft.) cable																						4
50 m (165 ft.) cable																						5
80 m (260 ft.) cable																						6
100 m (325 ft.) cable																						7
150 m (490 ft.) cable																						8
Special Length > 150 m (> 490 ft.) (and / or armored cable)																						9
Explosion protection certification																						
General purpose (non-Ex design)																						A
FM Class 1 Div. 2 (DN≥700, DN≤1600)																						G
FMc Class 1 Div. 2 (DN≥700, DN≤1600)																						P
Others																						Z
Protection class transmitter / protection class sensor																						
IP67 (NEMA 4X) / IP68 (NEMA 6P) – cable not fitted and not potted																						2
IP67 (NEMA 4X) / IP68 (NEMA 6P) – cable fitted and potted																						3
Cable conduits *																						
M20 x 1.5																						A
NPT 1/2 in (blanked when cable not fitted)																						B
M20 SWA armored																						D
M20 SWA sensor, output and power connector																						F
Power supply																						
Without (FEF18 only)																						0
100... 230 V AC (50 Hz)																						1
24 V AC or 24 V DC (50 Hz)																						2
100... 230 V AC (60 Hz)																						3
24 V AC or 24 V DC (60 Hz)																						4
Input and output signal type																						
HART + 20 mA + pulse + contact output																						A
PROFIBUS DP RS485 physical layer + pulse + contact output (FEF121 only)																						G
MODBUS RTU RS485 physical layer + pulse + contact output (FEF121 only)																						M
Without (FEF181 only)																						Y
Configuration type / diagnostics type																						
Without (FEF18 only)																						0
Factory defaults / standard diagnostics (FEF12 only)																						1
Options**																						
Documentation language																						
German	M1	English	M5 (default)																			
Italian	M2	Portuguese	MA																			
Spanish	M3	Russian	MB																			
French	M4	Danish	MF																			
Verification type																						
Without fingerprint																						V0
VeriMaster																						V3
Potable water approvals (Elastomer liner only)																						
WRAS																						CWA
NSF-61																						CWC
ACS																						CWF
Power supply frequency (sensor FEF 18 only)																						
50 Hz																						F5
60 Hz																						F6

* The type of signal cable supplied (standard or armored) depends on the type of cable conduit (variant digit number 24) ordered.

For FM or FMC Approved versions, NPT only permitted.

**Add codes for options.

Electromagnetic flowmeter WaterMaster FEV11, FEV12 and FEV18

Variant digit number	1 ... 5	6	7 ... 9	10	11	12	13	14, 15	16	17	18	19	20	21	22	23	24	25	26	27	Options
Flowmeter system, optimized full bore, integral mount	FEV11																				
Flowmeter system, optimized full bore, remote mount	FEV12		XXX	X	X	X	X	XX	X	X	X	X	X	X	X	X	X	X	X	X	
Optimized full bore sensor only, for use with WaterMaster transmitter/remote	FEV18																				
Design																					
Non-hazardous areas		1																			
Hazardous areas		5																			
Bore diameter																					
DN40 (1½ in)			040																		
DN50 (2 in)			050																		
DN65 (2½ in)			065																		
DN80 (3 in)			080																		
DN100 (4 in)			100																		
DN125 (5 in)			125																		
DN150 (6 in)			150																		
DN200 (8 in)			200																		
Liner material																					
Polypropylene				V																	
Electrode design																					
Standard					1																
Measuring electrodes material																					
Stainless steel 316						S															
Hastelloy® C-22						C															
Super-austenitic steel						U															
Grounding accessories																					
Standard											1										
One potential equalizer ring																					
Two potential equalizer rings																					
Process connection type																					
Flanges ASME B16.5 class 150																					A1
Flanges AS 4087 PN21 (≥ DN50 [2 NB])																					E0
Flanges AS 4087 PN16 (≥ DN50 [2 NB])																					E1
Flanges AS 4087 PN14																					E2
Flanges AS 2129 Table F																					E3
Flanges AS 2129 Table E																					E4
Flanges AS 2129 Table D																					E5
Flanges AS 2129 Table C																					E6
Flanges JIS G5527 7.5K (≥ DN100 [4 NB])																					J0
Flanges JIS B2220 10K																					J1
ISO/EN PN10																					S1
ISO / EN PN16 (≥ DN50 [2 NB])																					S2
ISO / EN PN40 (DN40 [1½ NB] only) 16 bar rated																					S4
Process connection material																					
Carbon steel flanges																					B
Usage certifications																					
Standard																					1
Calibration type																					
Class 2 Calibration – standard accuracy 0.4 %																					A
Class 1 Calibration – enhanced accuracy 0.2 %																					B
Extended range, class 2 calibration – standard accuracy 0.4 %																					N
Extended range, class 1 calibration – high accuracy 0.2 %																					P

Continued on page 24

Variant digit number	1 ... 5	6	7 ... 9	10	11	12	13	14, 15	16	17	18	19	20	21	22	23	24	25	26	27	Options
Flowmeter system, optimized full bore, integral mount	FEV11																				
Flowmeter system, optimized full bore, remote mount	FEV12		XXX	X	X	X	X	XX	X	X	X	X	X	X	X	X	X	X	X	X	
Optimized full bore sensor only, for use with WaterMaster transmitter/remote	FEV18																				
Temperature range installation / ambient temperature range																					Options
Standard design/ -20 ... 60 °C (-4 ... 140 °F)																					
Nameplate																					Options
Adhesive																					
Signal cable length and type *																					Options
Without signal cable																					
5 m (15 ft.) cable (FEV12 and FEV18 only)																					0
10 m (30 ft.) cable (FEV12 and FEV18 only)																					1
20 m (60 ft.) cable (FEV12 and FEV18 only)																					2
30 m (100 ft.) cable (FEV12 and FEV18 only)																					3
50 m (165 ft.) cable (FEV12 and FEV18 only)																					4
80 m (260 ft.) cable (FEV12 and FEV18 only)																					5
100 m (325 ft.) cable (FEV12 and FEV18 only)																					6
150 m (490 ft.) cable (FEV12 and FEV18 only)																					7
Special Length > 150 m (> 490 ft.) (FEV12 and FEV18 only)																					8
Explosion protection certification																					Options
General purpose (non-Ex design)																					
FM Class 1 Div. 2																					A
FMc Class 1 Div. 2																					G
Others																					P
Protection class transmitter / protection class sensor																					Options
IP67 (NEMA 4X) / IP67 (NEMA 4X) – integral (FEV11 only)																					
IP67 (NEMA 4X) / IP68 (NEMA 6P) – cable not fitted and not potted (FEV12 and FEV18 only)																					1
IP67 (NEMA 4X) / IP68 (NEMA 6P) – cable fitted and potted (FEV12 and FEV18 only)																					2
Cable conduits *																					Options
M20 x 1.5																					
NPT 1/2 in (blanked when cable not fitted)																					A
M20 SWA armored (FEV121 and FEV181 only)																					B
M20 SWA sensor, output and power connector (FEV121 and FEV181 only)																					D
Power supply																					Options
Without (FEV181 only)																					
100... 230 V AC, 50 Hz																					0
24 V AC or 24 V DC, 50 Hz																					1
100... 230 V AC, 60 Hz																					2
24 V AC or 24 V DC, 60 Hz																					3
Others																					4
Input and output signal type																					Options
HART + 20 mA + pulse + contact output																					
PROFIBUS DP RS485 physical layer + pulse + contact output (FEV111 and FEV121 only)																					A
MODBUS RTU RS485 physical layer + pulse + contact output (FEV111 and FEV121 only)																					G
Without (FEV181 only)																					M
Configuration type / diagnostics type																					Options
Without (FEV18 only)																					
Factory defaults / standard diagnostics (FEV11 and FEV12 only)																					0
																					1

Continued on page 25

* The type of signal cable supplied (standard or armored) depends on the type of cable conduit (variant digit number 24) ordered.
For FM or FMC Approved versions, NPT only permitted.

WaterMaster
Electromagnetic flowmeter

Variant digit number		1 ... 5	6	7 ... 9	10	11	12	13	14, 15	16	17	18	19	20	21	22	23	24	25	26	27	Options	
Flowmeter system, optimized full bore, integral mount		FEV11																					
Flowmeter system, optimized full bore, remote mount		FEV12		XXX	X	X	X	X	XX	X	X	X	X	X	X	X	X	X	X	X	X		
Optimized full bore sensor only, for use with WaterMaster transmitter/remote		FEV18																					
Options**																							
Documentation language																							
German	M1	English	M5 (default)																				
Italian	M2	Portuguese	MA																				
Spanish	M3	Russian	MB																				
French	M4	Danish	MF																				
Other usage certifications																							
Measuring Instruments Directive (MID)		CM1																					
OIML R49 Calibration		CM2																					
Verification type																							
Without fingerprint		V0																					
VeriMaster		V3																					
Potable water approval																							
NSF-61		CWC																					
Power supply frequency (sensor FEV18 only)																							
50 Hz	F5	60 Hz	F6																				

**Add codes for options.

WaterMaster FER reduced-bore sensor flowmeter series

Product coding field number		1,2,3,4,5,6	7,8,9	10	11	12	13	14,15	16	17	18	19	20	21	22	23	24	25	26	27	Options		
WaterMaster system. Reduced-bore sensor with remote mounted transmitter		FER121																				Add as required – see page 20	
WaterMaster system. Reduced-bore sensor with integral transmitter		FER111	XXX	X	X	X	X	XX	X	X	X	X	X	X	X	X	X	X	X	X	X		
WaterMaster reduced-bore sensor only, remote mount, without transmitter		FER181																					
Bore diameter																							
DN 40	1½ in.	040																					
DN 50	2 in.	050																					
DN 65	2½ in.	065																					
DN 80	3 in.	080																					
DN 100	4 in.	100																					
DN 125	5 in.	125																					
DN 150	6 in.	150																					
DN 200	8 in.	200																					
DN 250	10 in.	250																					
DN 300	12 in.	300																					
DN 350	14 in.	350																					
DN 375	15 in.	375																					
DN 400	16 in.	400																					
DN 450	18 in.	450																					
DN 500	20 in.	500																					
DN 600	24 in.	600																					
Liner material																							
Elastomer																							
Electrode design																							
Standard																							
Measuring electrodes material																							
Stainless steel 316																							
Super austenitic steel (1.4529)																							
Grounding accessories																							
1 x Stainless steel equalizing ring																							
2 x Stainless steel equalizing rings																							
Process connection type																							
Flanges ANSI / ASME B16.5 / 16.47 series B Class 150		(40 / 50 / 80 / 100 / 150 ... 300)																					
Flanges AWWA C207 Class E		(40 / 50 / 80)																					
Flanges JIS 7.5K		(100 / 150 ... 300)																					
Flanges JIS 10K		(40 / 50 / 80 / 100 / 150 ... 300)																					
Flanges AS 4087 PN 21		(50 / 80 / 100 / 150 ... 600)																					
Flanges AS 4087 PN 16		(50 / 80 / 100 / 150 ... 350 / 450 ... 600)																					
Flanges AS 4087 PN 14		(40 / 50 / 80 / 100 / 150 ... 600)																					
Flanges AS 2129 Table F		(40 / 50 / 80 / 100 / 150 ... 600)																					
Flanges AS 2129 Table E		(40 / 50 / 80 / 100 / 125 / 150 ... 600)																					
Flanges AS 2129 Table D		(40 / 50 / 80 / 100 / 150 ... 300)																					
Flanges AS 2129 Table C		(40 / 50 / 80 / 100 / 150 ... 300)																					
ISO 7005 PN 10 EN 1092-1		(40 ... 600)																					
ISO 7005 PN 16 EN 1092-1		(40 ... 600)																					
ISO 7005 PN 40 EN 1092-1		(40)																					
Process connection material																							
Carbon steel																							
Usage certifications																							
Standard																							

Continued on page 27

Product coding field number	1,2,3,4,5,6	7,8,9	10	11	12	13	14,15	16	17	18	19	20	21	22	23	24	25	26	27	Options																
										See previous page																										
Calibration type																																				
Class 2 calibration – standard accuracy 0.4 %											A																									
Class 1 calibration – enhanced accuracy 0.2											B																									
Extended range calibration (Class 1) – standard accuracy 0.4 %											N																									
Extended range calibration (Class 2)– enhanced accuracy 0.2 %											P																									
Installation temperature range / ambient temperature range																																				
Standard design –20 ... 60 °C (–4 ... 140 °F)												1																								
Name plate																																				
Adhesive label												A																								
Signal cable length and type																																				
Without signal cable												0																								
5 m (16.4 ft)												1																								
10 m (32.8 ft)												2																								
20 m (65.6 ft)												3																								
30 m (98.4 ft)												4																								
50 m (164.0 ft)												5																								
80 m (262.5 ft)												6																								
100 m (325 ft)												7																								
150 m (490 ft)												8																								
Others												9																								
Explosion protection certification																																				
General purpose (non-Ex design)																				A																
Protection class transmitter / protection class sensor																																				
IP67 (NEMA 4X) / IP68 (NEMA 6P) – cable not fitted and not potted																					2															
IP67 (NEMA 4X) / IP68 (NEMA 6P) – cable fitted and potted																					3															
Cable conduits*																																				
M20 x 1.5																						A														
NPT 1/2 in (blanked when cable not fitted)																							B													
M20 SWA armored (FEV121 and FEV181 only)																							D													
M20 SWA sensor, output and power connector (FEV121 and FEV181 only)																							F													
Power supply																																				
Without (FEV18 only)																								0												
100... 230 V AC, 50 Hz																										1										
24 V AC or 24 V DC, 50 Hz																										2										
100... 230 V AC, 60 Hz																											3									
24 V AC or 24 V DC, 60 Hz																											4									
Input and output signal type																																				
HART + 20 mA + pulse + contact output																											A									
PROFIBUS DP RS485 physical layer + pulse + contact output (FEV111 and FEV121 only)																													G							
MODBUS RTU RS485 physical layer + pulse + contact output (FEV111 and FEV121 only)																														M						
Without (FEV181 only)																														Y						
Configuration type / diagnostics type																																				
Without (FEV18 only)																															0					
Factory defaults / standard diagnostics (FEV11 and FEV12 only)																																1				
Options**																																				
Documentation language																																				
German	M1	English	M5 (default)																																	
Italian	M2	Portuguese	MA																																	
Spanish	M3	Russian	MB																																	
French	M4	Danish	MF																																	
Other usage certifications																																				
Measuring Instruments Directive (MID)																													CM1 (DN40 to DN300 only, pending)							
OIML R49 Calibration																												CM2 (DN40 to DN300 only, pending)								
Verification type																																				
Without fingerprint																																V0				
VeriMaster																																V3				
Potable water approval																																				
WRAS																																			CWA	
ACS																																				CWF
Power supply frequency (sensor FER18 only)																																				
50 Hz	F5	60 Hz	F6																																	

* The type of signal cable supplied (standard or armored) depends on the type of cable conduit (variant digit number 24) ordered.
For FM or FMC Approved versions, NPT only permitted.

**Add codes for options.

Electromagnetic flowmeter WaterMaster – FEW11, FEW12 and FEW18

Variant digit number	1 ... 5	6	7 ... 9	10	11	12	13	14, 15	16	17	18	19	20	21	22	23	24	25	26	27	Options
Flowmeter system – full bore, integral mount (DN10 to DN32 Only)	FEW11																				
Flowmeter system – full bore, remote mount	FEW12		XXX	X	X	X	X	XX	X	X	X	X	X	X	X	X	X	X	X	X	
Full bore sensor only – for use with WaterMaster transmitter/remote	FEW18																				
Design																					
Non-hazardous areas			1																		
Hazardous areas			5																		
Bore diameter																					
DN10 (3/8 in)			010																		
DN15 (1/2 in)			015																		
DN20 (3/4 in)			020																		
DN25 (1 in)			025																		
DN32 (1 1/4 in)			032																		
Liner material																					
PTFE																					A
Electrode design																					
Standard																					1
Other																					9
Measuring electrodes material																					
Hastelloy® C-4 (2.4610)																					D
Grounding accessories																					
Not required																					0
One potential equalizing ring (stainless steel)																					3
Two potential equalizing rings (stainless steel)																					4
Other																					9

Continued on page 29

Variant digit number	1 ... 5	6	7 ... 9	10	11	12	13	14, 15	16	17	18	19	20	21	22	23	24	25	26	27	Options
Flowmeter system – full bore, integral mount (DN10 to DN32 Only)	FEW11																				
Flowmeter system – full bore, remote mount	FEW12		XXX	X	X	X	X	XX	X	X	X	X	X	X	X	X	X	X	X	X	
Full bore sensor only – for use with WaterMaster transmitter/remote	FEW18																				
Process connection type																					
ASME B16.5 B class 150								A1													
ASME B16.5 B class 300								A3													
ISO / EN PN40 – DN10 to DN32 only								S4													
DIN PN40								D4													
Other								Z9													
Process connection material																					
Carbon steel flanges – DN20 to DN32								B													
Stainless steel flange 1.4571 (316 Ti) – DN10 to DN15								D													
Other								Z													
Usage certifications																					
Standard (without PED)								1													
Other								9													
Calibration type																					
Class 2 calibration – standard accuracy 0.4 %								A													
Class 1 calibration – enhanced accuracy 0.2 %								B													
Extended range, class 2 calibration – standard accuracy 0.4 %								N													
Extended range, class 1 calibration – enhanced accuracy 0.2 %								P													
Temperature range installation / ambient temperature range																					
Standard design/ –20 ... 60 °C (–4 ... 140 °F)								1													
Nameplate																					
Adhesive								A													
Signal cable length and type																					
Without signal cable								0													
5 m (15 ft.) cable								1													
10 m (30 ft.) cable								2													
20 m (60 ft.) cable								3													
30 m (100 ft.) cable								4													
50 m (165 ft.) cable								5													
80 m (260 ft.) cable								6													
100 m (325 ft.) cable								7													
150 m (490 ft.) cable								8													
Special length or cable type								9													
Explosion protection certification																					
General purpose								A													
FM Class 1 Div. 2								G													
FMc Class 1 Div. 2								P													
Others								Z													

Continued on page 30

Variant digit number	1 ... 5	6	7 ... 9	10	11	12	13	14, 15	16	17	18	19	20	21	22	23	24	25	26	27	Options
Flowmeter system – full bore, integral mount (DN10 to DN32 Only)	FEW11																				
Flowmeter system – full bore, remote mount	FEW12		XXX	X	X	X	X	XX	X	X	X	X	X	X	X	X	X	X	X	X	X
Full bore sensor only – for use with WaterMaster transmitter/remote	FEW18																				
Protection class transmitter / protection class sensor																					
IP67 (NEMA 4X) / IP67 (NEMA 4X) – cable not fitted and potted to sensor (DN10 to DN32 only)																1					
IP67 (NEMA 4X) / IP67 (NEMA 4X) – cable fitted and potted to sensor (DN10 to DN32 only)																7					
Cable conduits *																					
M20 (Plastic) – glands: all 20 mm plastic																A					
NPT 1/2 in (blanked when cable not fitted)																B					
M20 SWA (armored) – glands: all 20 mm armored																D					
M20 SWA sensor, M20 others – glands: 20 mm armored for sensor connections, plastic for other connections																F					
Not required																Y					
Other																Z					
Power supply																					
Without																0					
100... 230 V AC, 50 Hz																1					
24 V AC or 24 V DC, 50 Hz																2					
100... 230 V AC, 60 Hz																3					
24 V AC or 24 V DC, 60 Hz																4					
Input and output signal type																					
HART + 20 mA + pulse + contact output																A					
PROFIBUS DP RS485 physical layer + pulse + contact output (FEW111 and FEW121 only)																G					
MODBUS RTU RS485 physical layer + pulse + contact output (FEW111 and FEW121 only)																M					
Without																Y					
Configuration type / diagnostics type																					
Not required (FEW38 only)																0					
Standard / Standard (FEW31 and FEW32 only)																1					
Options**																					
Documentation language																					
German	M1	English	M5 (default)																		
Italian	M2	Portuguese	MA																		
Spanish	M3	Russian	MB																		
French	M4	Danish	MF																		
Verification type																					
Without fingerprint																V0					
VeriMaster																V3					
Power supply frequency (sensor FEW 18 only)																					
50 Hz	F5	60 Hz	F6																		

* For FM or FMC Approved versions, NPT only permitted.

** Add codes for options.

Electromagnetic flowmeter transmitter for WaterMaster FET10 and FET12

		Variant digit number															Options
		1 ... 5	6	7	8	9	10	11	12	13	14	15					
Transmitter converter module		FET10															
Remote transmitter		FET12															
Design																	
Non-hazardous area		1															
Hazardous area		5															
Temperature range installation / ambient temperature range																	
Standard design / -20 ... 60 °C (-4 ... 140 °F)		1															
Nameplate																	
Adhesive		A															
Signal cable length and type																	
Without signal cable		0															
Explosion protection certification																	
Without (transmitter only)		Y															
FM Class 1 Div. 2		G															
FMc Class 1 Div. 2		P															
Others		Z															
Protection class transmitter / protection class sensor																	
IP67 (NEMA 4X) / IP67 (NEMA 4X)		1															
Cable conduits																	
M20 x 1.5 (FET121 only)		A															
NPT 1/2 in (FET121 only)		B															
M20 SWA armored (FET121 only)		D															
M20 Plastic power/output + M20 SWA armored sensor cable entry (FET121 only)		F															
Power supply																	
100... 230 V AC		1															
24 V AC or 24 V DC		2															
Input and output signal type*																	
HART + 20 mA + pulse + contact output		A															
PROFIBUS DP RS485 physical layer + pulse + contact output (FET101 and FET121 only)		G															
MODBUS RTU RS485 physical layer + pulse + contact output (FET101 and FET121 only)		M															
Configuration type / diagnostics type																	
Factory defaults/standard diagnostics		1															
Options**																	
Documentation language																	
German	M1	English	M5 (default)														
Italian	M2	Portuguese	MA														
Spanish	M3	Russian	MB														
French	M4	Danish	MF														
Other usage certifications																	
Measuring Instruments Directive (MID)		CM1															

*The transmitter converter module Input and Output Signal Type must match the transmitter backplane output configuration (HART or PROFIBUS) – see IM/WM.

**Add codes for options.

Contact us

ABB Limited

Process Automation

Oldends Lane
Stonehouse
Gloucestershire GL10 3TA
UK

Tel: +44 1453 826 661

Fax: +44 1453 829 671

ABB Inc.

Process Automation

125 E. County Line Road
Warminster
PA 18974
USA

Tel: +1 215 674 6000

Fax: +1 215 674 7183

ABB Engineering (Shanghai) Ltd.

No. 5, Lane 369, Chuangye Road
201319, Shanghai,
P.R. China

Phone: +86 (0) 21 6105 6666

Fax: +86 (0) 21 6105 6992

Mail: china.instrumentation@cn.abb.com

www.abb.com

Note

We reserve the right to make technical changes or modify the contents of this document without prior notice. With regard to purchase orders, the agreed particulars shall prevail. ABB does not accept any responsibility whatsoever for potential errors or possible lack of information in this document.

We reserve all rights in this document and in the subject matter and illustrations contained therein. Any reproduction, disclosure to third parties or utilization of its contents – in whole or in parts – is forbidden without prior written consent of ABB.

Copyright© 2012 ABB

All rights reserved

3KXF211101R1001

Microsoft is a registered trademark of Microsoft Corporation in the United States and/or other countries

Modbus is a registered trademark of the Modbus-IDA organization

HART is a registered trademark of the HART Communication Foundation