

- **Flow Meter Industry's first Predictive Diagnostic System**
  - Advance warning of system failure crashes
- **Designed to work with both battery- and mains-powered flowmeters:**
  - MagMaster Water Waste
  - MagMaster Process
  - MagMaster LoFlo
  - AquaMaster
  - AquaMaster Explorer
- **Instant on-site results**
  - Results displayed as tests are performed
- **Advanced helpline and customer support**
  - Web registration
  - Fingerprint downloads
- **Battery operated**
  - 100 tests before download
  - Ideal for remote applications
- **Backwards compatibility with all existing ABB flowmeter systems**
  - Designed to work with the complete range of flowmeters
- **2 versions available:**
  - CheckMaster validation tool
  - CalMaster2 verification tool



The world's first battery- and mains-powered in situ flow verification system

## History

For over a decade CalMaster has been the solution to demands for in situ calibration verification and certification – a world first from ABB that enables calibration verification without the need to remove the sensor.

The ABB CalMaster MagMaster verification system has been used with great success in the global water industry, saving water utilities vast sums of money in expensive repair maintenance plans.

CalMaster has also been used to verify, in situ, existing MagMasters giving an error of  $\pm 1$  % of original calibration certificate.

## Introduction

CalMaster2 is a suite of stand-alone field verification tools for use with ABB's range of electronic flow meters, that enables users to test the integrity of flow meter systems. The verification consists of a large number of separate test routines. A report is displayed of each test as it verifies the condition and performance of the flow meter under test.

There is no need to carry a laptop computer on site as up to 100 verifications can be stored and then downloaded after the site visit.

A CalMaster2 record is produced once further analysis of the test results has taken place. Each CalMaster2 is returned to the factory each year for a renewal of its recalibration certification.

There are two levels of functionality:

### ■ CheckMaster Field-validation Tool

CheckMaster consists of:

- CheckMaster Verification Tool
- CalMaster2 IRIS Software

CheckMaster displays the results of each test during the testing sequence. At the end of each test, a record is stored locally within the CheckMaster (up to 100 test results can be stored).

The stored test results can be uploaded and a service report generated.

### ■ CalMaster2 Verification Tool and enhanced CalMaster2 IRIS software

CalMaster2 consists of:

- CalMaster2 Verification Tool
- Enhanced CalMaster2 IRIS Software

CalMaster2 displays the results of each test during the testing sequence. At the end of each test, a record is stored locally within the CalMaster2 (up to 100 test results can be stored).

Once CalMaster2 is connected to a PC that is running the CalMaster2 software, the stored test results can be uploaded and processed.

Enhanced CalMaster2 IRIS software enables the printing of service reports. Certification is to within 1 % of factory calibration for fingerprinted flow meters or 2 % for non-fingerprinted flow meters.

Predictive diagnostics are also provided to show early warning of a possible system failure, enabling maintenance engineers to anticipate problems and take planned remedial action in advance.

## Ease of Operation

The ease of operation of CalMaster2 is of real benefit to the user. Once verification is complete, the CalMaster2 can be plugged into a PC or laptop (communications leads are provided) and CalMaster2 software then provides a list of verifications and the status of each flow meter.

The CalMaster2 is very easy to operate. It has a user-friendly Windows-based software package that enables all verification results to be evaluated and a certificate to be printed when required.

## Condition Monitoring

A major benefit of CalMaster2 is that it can also be used as a diagnostic and condition-monitoring tool. It stores all the measured values automatically and generates a log for easy long-term trend analysis.

Detailed observation can give early warning of a possible system failure, enabling maintenance engineers to anticipate problems and take planned remedial action in advance.

## Dimensions

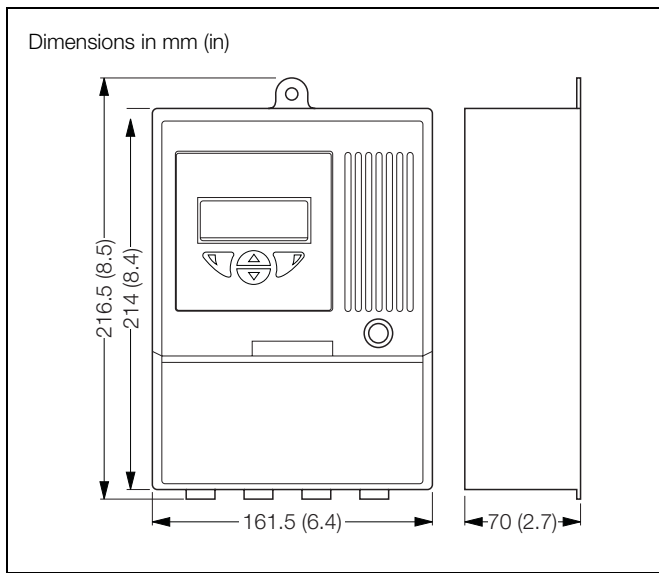

## CheckMaster Supply Pack

Includes:

- CheckMaster Field-validation tool
- CalMaster2 IRIS software CD ROM
- Instruction Manual
- Mains-operated battery charger
- Connection leads (all interconnection cables for quick and easy connection to all variants of MagMaster and AquaMaster)
- 5 MagMaster VKE adaptor PCBs

## CalMaster2 Supply Pack

Includes:

- CalMaster2
- CalMaster2 IRIS software CD ROM
- Instruction Manual
- Mains-operated battery charger
- Connection leads (all interconnection cables for quick and easy connection to all variants of MagMaster and AquaMaster)
- 5 MagMaster VKE adaptor PCBs

## Spares

### AquaMaster Communications Leads

(red and yellow numeric sleeves):

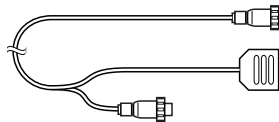

Connection Lead 1  
WEBC0221

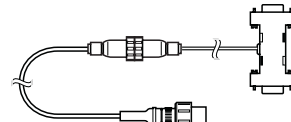

WEBC2000 for RS232 Serial  
Communications  
WEC2000

### AquaMaster Explorer Leads

(red numeric sleeves):

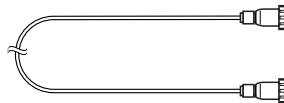

AquaMaster Transmitter  
Connection Lead 2  
WEBC0222

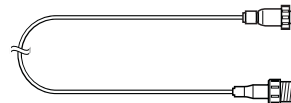

AquaMaster Transmitter  
Connection Lead 3  
WEBC0223

### MagMaster Leads

(yellow numeric sleeves):

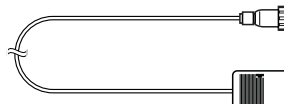

MagMaster Connection Lead 2  
WEBC0212

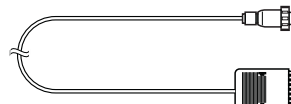

MagMaster Connection Lead 3  
WEBC0213

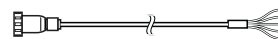

AquaMaster Transmitter Connection Lead 2  
WEBC0211

### AquaMaster MIL Connector Leads

(green numeric sleeves):



AquaMaster MIL Sensor Cable  
WEBC0233

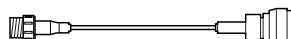

AquaMaster 19-way Output Cable  
WEBC0213

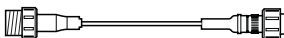

AquaMaster 7-way Output Cable  
WEBC0234

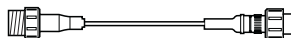

AquaMaster 7-way Output Cable  
WEBC0232

MagMaster VKE adaptor PCB	WADX0089
Mains-operated battery charger	WEBC0204
In-car battery charger lead	WEBC0205
CalMaster2 CD ROM	WAHX0200
CalMaster2 manual	IM/VCM2
AquaMaster MIL upgrade kit	WEBC0206

## Ordering Information

CalMaster2	V/CM2	X	X	X	X
<b>Option</b>					
Not required – recalibration only		0			
CheckMaster		1			
CalMaster2		2			
<b>License &amp; Training</b>					
Not required			0		
CheckMaster			1		
CalMaster2			2		
CalMaster2 – feeder factory only			3		
<b>Recalibration</b>					
Not required				0	
CheckMaster				1	
CalMaster2				2	
<b>Language</b>					
English					0
German					D
Spanish					E
French					F
Italian					I

## Specification

### Verification Accuracy

#### CheckMaster

Field-validation tool for producing conformance reports

#### CalMaster2

±1 % of complete system with all ABB Magmeters that have been fingerprinted at calibration

### Protection

IP65

### Temperature Range:

0 to 50 ° C (32 to 122 ° F)

### Power Supply:

Internal rechargeable battery with up to six hours continuous operation

ABB has Sales & Customer Support expertise in over 100 countries worldwide

[www.abb.com](http://www.abb.com)

The Company's policy is one of continuous product improvement and the right is reserved to modify the information contained herein without notice.

Printed in UK (02.08)

© ABB 2008



#### ABB Limited

Oldends Lane,  
Stonehouse  
Gloucestershire  
GL10 3TA  
UK

Tel: +44 (0)1453 826661  
Fax: +44 (0)1453 829671

#### ABB Inc.

125 E. County Line Road  
Warminster  
PA 18974  
USA

Tel: +1 215 674 6000  
Fax: +1 215 674 7183