

TBX587 pH / Redox (ORP) sensor

Retractable sensor assembly for industrial applications

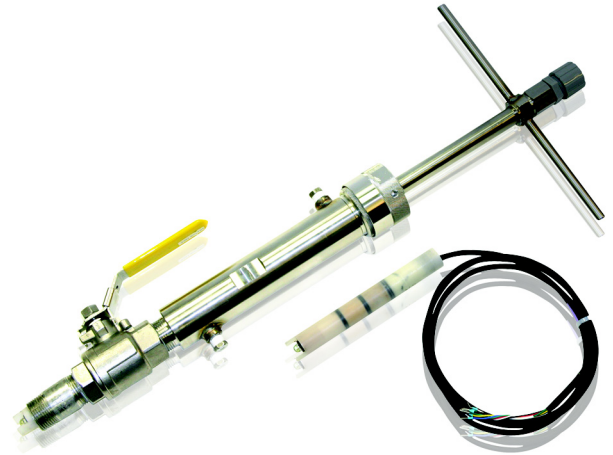

1-Inch Retractable Sensor

- Specifically designed for smaller sample line installations

Quick Response Thermal Compensator

- Provides accurate pH measurement even with changing process temperature

150 PSIG Maximum Pressure Rating

- Easy 'T' Handle for insertion into pressurized process

Next Step™ Solid State Reference

- Eliminates Poisoning, Pumping and Plugging

Solution Ground Rod

- Permits continuous sensor diagnostics

Variety of Sensor Wiring Options

- Vario Pin and pinned leads wiring options

Operating Temperature up to 140 °C (284 °F)

- The highest glass temperature limit on the market

Combination Electrode Style Construction

- Measuring, reference, and temperature element all-in-one compact sensor body

TBI Heritage

- Based on the most successful harsh application pH sensor design on the market

TBX587 pH / Redox (ORP) sensor

A new addition to the Most Durable pH / Redox (ORP) Sensors product line in the World

The Endura TBX587 is the latest addition to ABB's successful line of industrial pH sensors. A well-deserved reputation for ruggedness, longevity, and accuracy hallmark the TBX5 Series pH sensors. The sensors are easily applied to most industrial measurement needs. They are renowned for their ability to outperform conventional gel-filled sensors in the toughest process applications.

Combating Reference Electrode Failures

Solid State Next Step reference technology is the foundation for all TBX5 Series pH electrodes. The totally solid inner reference chamber is charged with Potassium Chloride (KCl). This non-liquid reference chamber all but eliminates poisoning, pumping, and plugging problems that plague conventional liquid, slurry, and gel designs.

The standard solution ground rod allows for continuous monitoring of glass breakage, shorts, and reference coating and contamination. ABB offers a wide variety of solution ground materials and o-ring options suitable for most any industrial processes.

Durable Electrodes

The TBX587 electrode design eliminates failures due to thermal stress caused by rapid temperature excursions. Unlike other pH sensors that use a large inner air bubble for expansion absorption, the TBX587 electrodes use a unique inner plunger; providing more effective protection against temperature fluctuations.

The glass manufacturing process uses inoffensive components. The glass contains no barium, cobalt, or uranium oxides. The impedance is low enough to maintain signal integrity, yet high enough to remain

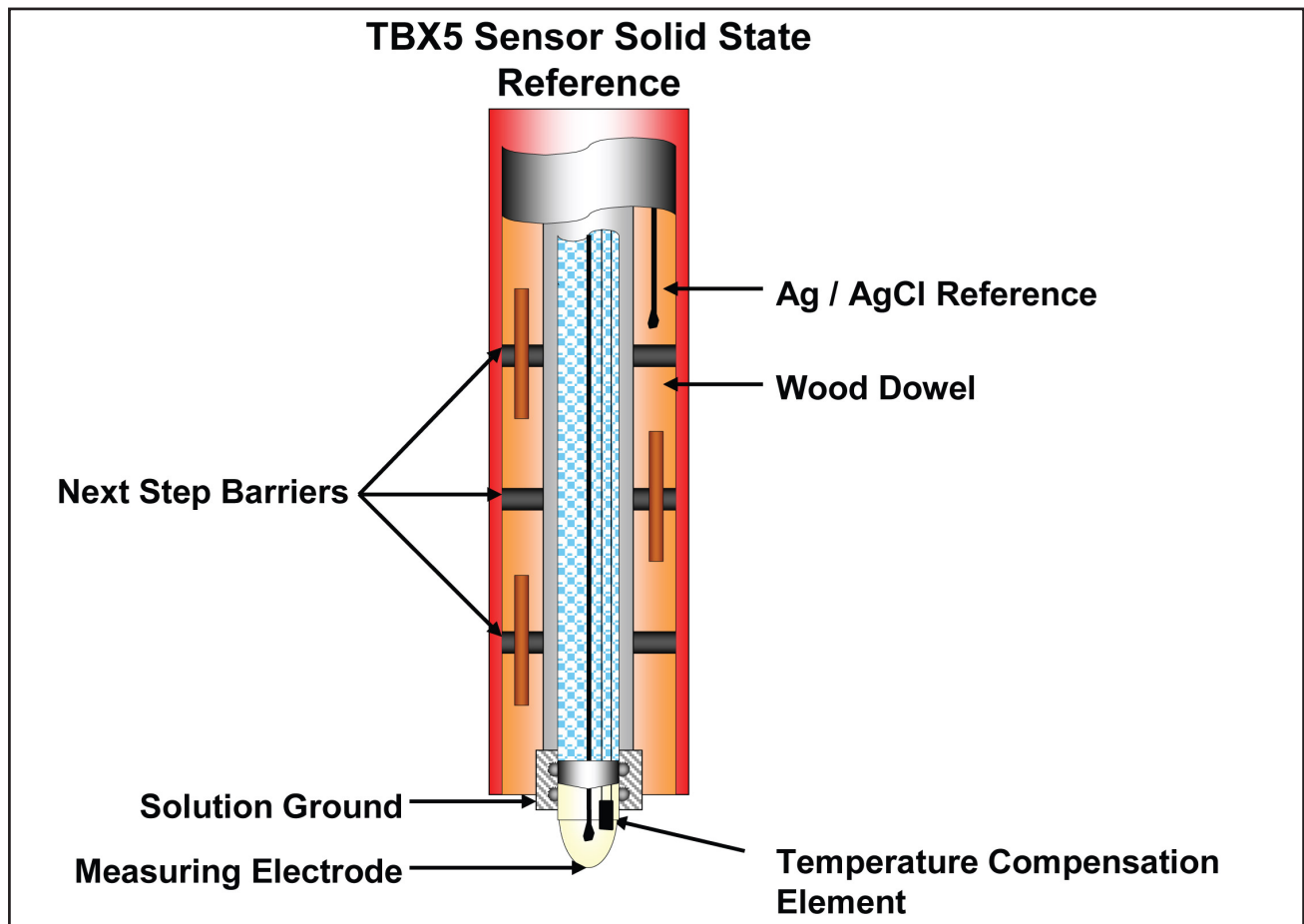

TBX587 Temperature Electrode Performance

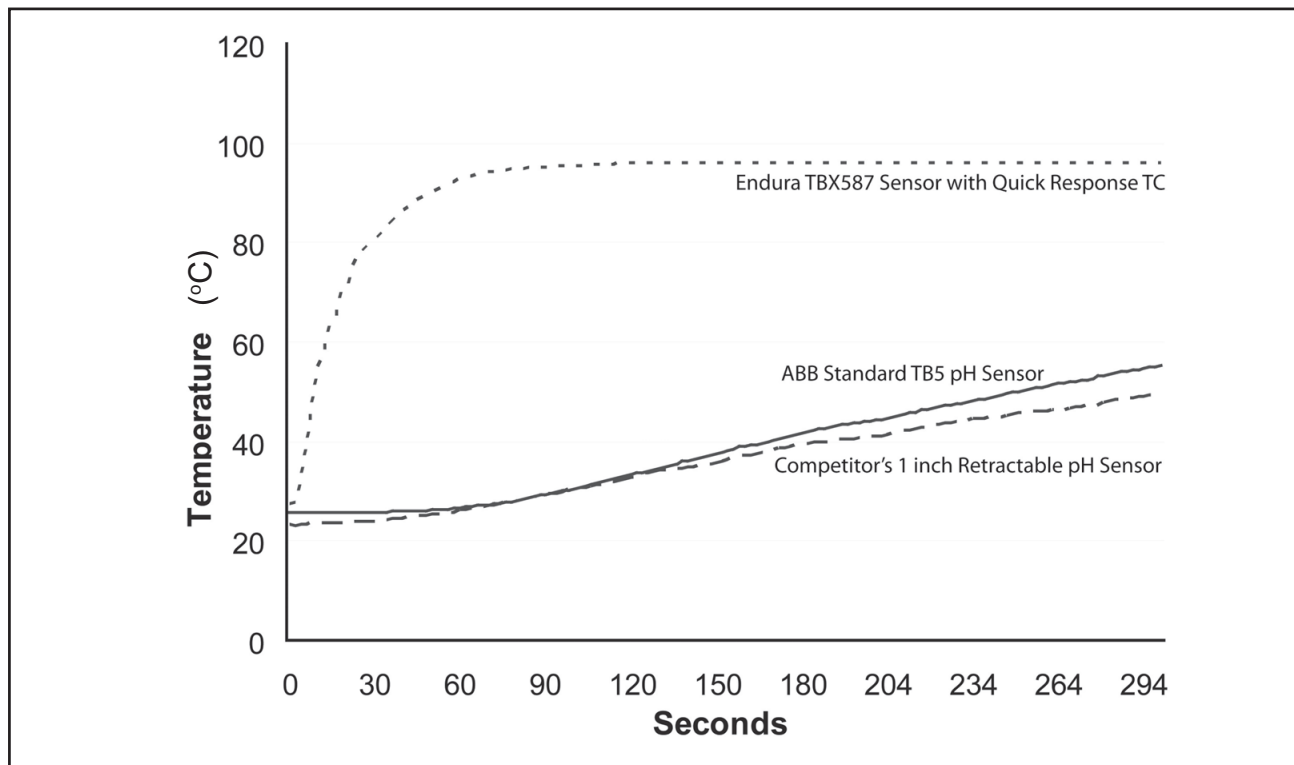

Reference Junction Styles

To promote TBX587 electrode process efficiency, reference junctions are available as either wood or PTFE. A standard notched tip is offered to protect the measurement electrode from breakage.

The hardwood reference junction is highly recommended for all general purpose duties, particularly those requiring high resistance to coating. PTFE junctions are promoted for continuous processes over 11.0 pH or those containing known wood delignifiers such as strong caustics, bleaches, and other oxidizers.

Temperature Compensation

Temperature compensators enable pH analyzers to adjust for temperature effects on the glass pH electrode output (Nernst). Selected analyzer can also use this measurement to compensate for solution pH temperature effects.

The quick response temperature option offered on certain styles of our glass electrodes greatly improves the TBX587 temperature response over the competition.

The integral temperature compensator is available in

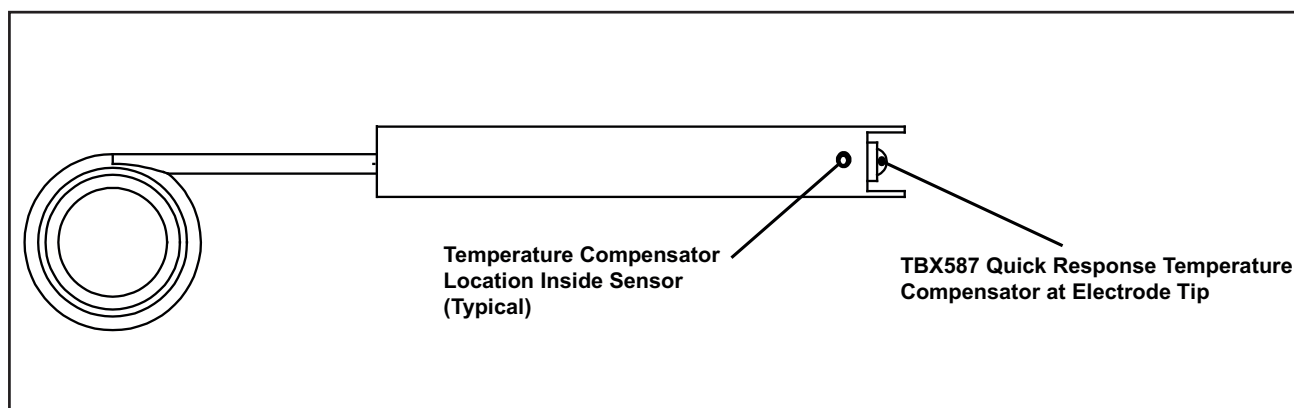

TBX587
pH / Redox (ORP) sensor

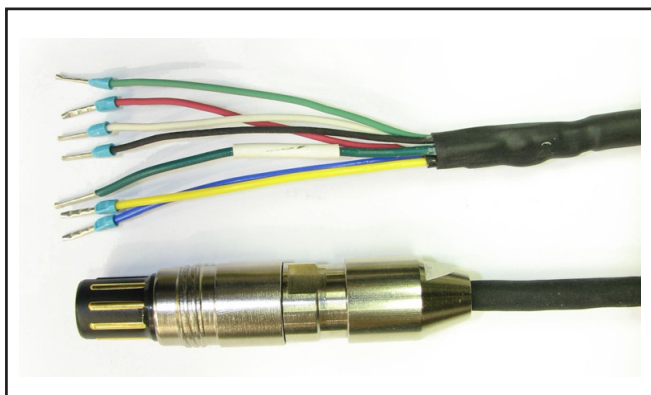
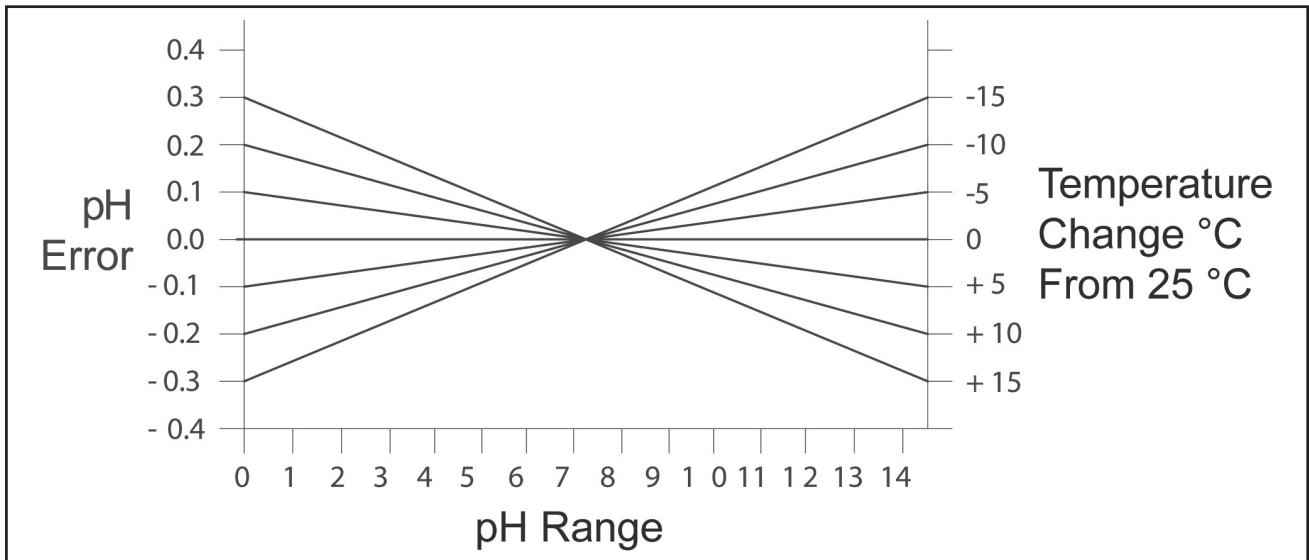

Cable Options

TBX587 Sensors offer two different cabling options to connect to a wide variety of pH electronics.

Pinned leads, code option "T", allow for direct wiring of the sensor to the pH electronics. This is ideal for cost savings and for short cable length applications where a quick disconnect wiring is not needed.

The Vario Pin option V provides a water tight (IP 68) quick disconnect option for difficult applications where the sensors will be frequently removed for cleaning, calibration or replacement.

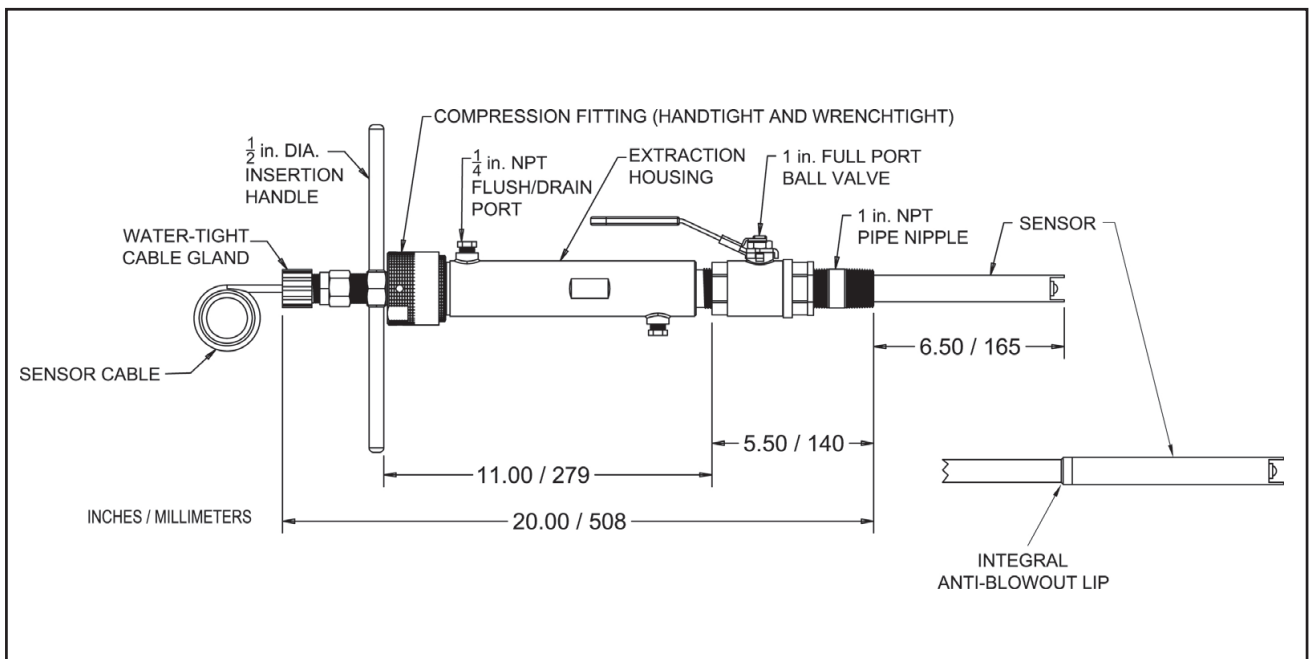

Specifications

Pressure Maximum

10.3 bar (150 PSI)

Temperature Compensator (pH sensors only)

Quick Response Integral Pt100 or 3 kΩ Balco

Wetted Material Options

Glass	pH Electrode
Platinum	Redox (ORP)
PTFE	Reference Junction
Wood	Reference Junction
PVDF	Sensor Body
Stainless Steel	Solution Ground + Hardware
Titanium	Solution Ground + Hardware
Hastelloy	Solution Ground + Hardware
EPDM	O-Rings
Viton	O-Rings
Kalrez	O-Rings

Measurement Electrode Type & Rating

Code	Type	Description	Ratings			
			Range	Operating		Quick TC Standard?
				°C	°F	
1	Flat Glass	Flush glass for slurries and high particulate applications.	0 ... 14 pH	10 ... 100 (Note 1)	60 ... 212 (Note 1)	Yes
2	General Purpose Glass	Low temperature and light duty applications. Not for high pH.	0 ... 12 pH	0 ... 100	32 ... 212	Yes
3	High Temp Glass	High Temperature glass electrode and special high temperature cable	0 ... 14 pH	10 ... 140	50 ... 284	Yes
8	Flat Redox (ORP)	Flush Platinum element. Well suited for slurry applications.	0 ... +2000 mV	0 ... 140	32 ... 284	No
6	Antimony (Sb)	Metal pH electrode for HF Acid or high abrasion applications.	3 ... 11 pH	-20 ... 80	-4 ... 176	No
F	Fluoride Resistant Glass	Etch resistant pH glass up to several % HF Acid concentration as well as other strong acids.	0 ... 12 pH	10 ... 80 (Note 2)	50 ... 176 (Note 2)	Yes
J	Coat Resistant Glass	Most common industrial glass electrode for applications with coating and build-up.	0 ... 14 pH	10 ... 140 (Note 3)	50 ... 284 (Note 3)	Yes

Notes 1) 0 to 121 °C (32 to 250 °F) for sterilization cycles

2) 50 °C (122 °F) maximum temperature recommended for high HF concentration

3) 90 °C (194 °F) maximum cable temperature

TBX587

pH / Redox (ORP) sensor

	Variant digit No.	1-6	7	8	9	10	11	12	13	14	15
Endura 1 inch Retractable pH / Redox (ORP) sensor assembly TBX587			X	X	X	X	X	X	X	X	X
Measurement Electrode											
Flat Glass (10 ... 100 deg °C, 0 ... 14 pH) For high particulates with flow at 90 deg			1								
General Purpose Glass (0 ...100 °C, 0 ... 12 pH) For low temperature applications			2								
High Temp Glass (10 ... 140 °C, 0 ... 14 pH) Sensor cable rated to 140 °C			3								
Platinum, (Flat ORP) (0 ... 140 °C, +/- 2000mV)			8								
Antimony (-20 ... 80 °C, 3 ... 11 pH)			6								
Glass, pH, Fluoride - Resistant (10 ... 80 °C, 0 ... 14 pH)			F								
Coat - Resistance Glass (10 ... 140 °C, 0 ... 14 pH) Sensor cable rated to 90 °C			J								
Integral Thermo compensator											
None, Replacement Sensor					0						
3 kOhm			1)	1							
Pt 100			1)	3							
Reference Junction											
Wood, Notched, Next Step				2)	D						
Teflon, Notched, Next Step				2)	E						
Solution Ground Wetted Material											
316 Stainless Steel with Viton O-Rings						1					
316 Stainless Steel with EPDM O-Rings						2					
316 Stainless Steel with Kalrez O-Rings						3					
Titanium with Viton O-Rings						4					
Titanium with EPDM O-Rings						5					
Titanium with Kalrez O-Rings						6					
Hastelloy B-2 with Viton O-Rings						7					
Hastelloy B-2 with EPDM O-Rings						8					
Hastelloy B-2 with Kalrez O-Rings						9					
Accessory Hardware											
None, Replacement Sensor								0			
Complete Hardware Assembly, Stainless with Viton O-Rings								A			
Complete Hardware Assembly, Stainless with EPDM O-Rings								B			
Complete Hardware Assembly, Stainless with Kalrez O-Rings								C			
Complete Hardware Assembly, Titanium with Viton O-Rings								D			
Complete Hardware Assembly, Titanium with EPDM O-Rings								E			
Complete Hardware Assembly, Titanium with Kalrez O-Rings								F			
Complete Hardware Assembly, Hastelloy C with Viton O-Rings								G			
Complete Hardware Assembly, Hastelloy C with EPDM O-Rings								H			
Complete Hardware Assembly, Hastelloy C with Kalrez O-Rings								J			
Sensor Cable Connection Options											
Tinned / Pin Leads									T		
Quick Disconnect Vario Pin Connector									V		
Sensor Cable Length											
5 ft (1.5 m)									3)	0	5
10 ft (3 m)									3)	1	0
20 ft (6 m)									3)	2	0
30 ft (9 m)									3)	3	0
Quick Disconnect Vario Pin Connector (Select Extension Cable Separately)										0	0
Tagging											
None											0
Mylar											1
Stainless Steel											2

1) No Integral Thermocompensator when Redox (ORP) or Antimony Electrode Selected for Digit 7.

2) Flush Reference Junction Supplied when Antimony Electrode Selected for Digit 7 (all other electrodes have notched tip).

3) Cable Length only for Tinned/Pinned Leads for Digit 12. Quick Disconnect option requires extension cable.

Accessories

1 in. Stainless Steel Ball Valve Kit (4TB4951-0118 + 4TB4955-0118)	4TB5205-0302
1 in. Titanium Ball Valve Kit (4TB4951-0119 + 4TB4955-0013)	4TB5205-0303
1 in. Hastelloy C Ball Valve Kit (4TB4951-0120 + 4TB4955-0014)	4TB5205-0304

Extension Cable

Vario Pin Interconnection Cable 5 ft. (2 m) Length	4TB3011-9005
Vario Pin Interconnection Cable 10 ft. (3 m) Length	4TB3011-9010
Vario Pin Interconnection Cable 20 ft. (6 m) Length	4TB3011-9020
Vario Pin Interconnection Cable 30 ft. (10 m) Length	4TB3011-9030
Vario Pin Interconnection Cable 50 ft. (15 m) Length	4TB3011-9050
Vario Pin Interconnection Cable 75 ft. (23 m) Length	4TB3011-9075
Vario Pin Interconnection Cable 100 ft. (30 m) Length	4TB3011-9100

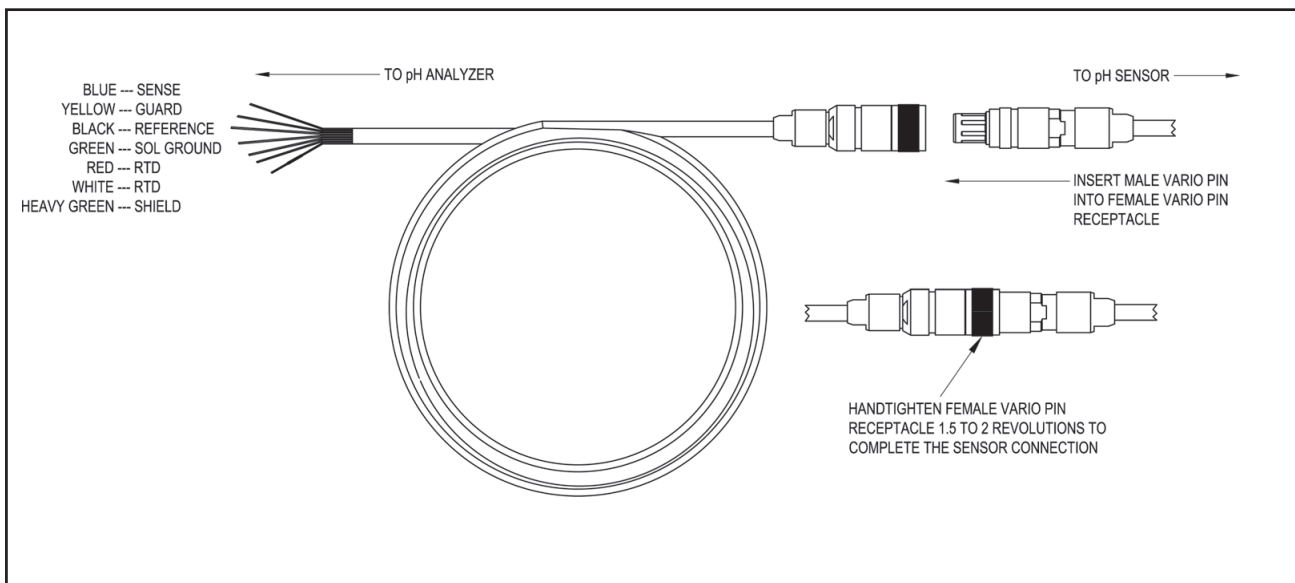

Contact us

ABB Inc.

Process Automation

843 N Jefferson Street

PO Box 831

Lewisburg 24901-9509

USA

Tel: +1 800 HELP 365 (435 7365)

Fax: +1 304 647 1862

ABB Limited

Process Automation

Oldends Lane

Stonehouse

Gloucestershire GL10 3TA

UK

Tel: +44 1453 826 661

Fax: +44 1453 829 671

ABB Engineering (Shanghai) Ltd.

Process Automation

No. 5, Lane 369, Chuangye Road

201319, Shanghai,

P.R. China

Phone: +86 (0) 21 6105 6666

Fax: +86 (0) 21 6105 6992

Mail: china.instrumentation@cn.abb.com

www.abb.com

Note

We reserve the right to make technical changes or modify the contents of this document without prior notice. With regard to purchase orders, the agreed particulars shall prevail. ABB does not accept any responsibility whatsoever for potential errors or possible lack of information in this document.

We reserve all rights in this document and in the subject matter and illustrations contained therein. Any reproduction, disclosure to third parties or utilization of its contents – in whole or in parts – is forbidden without prior written consent of ABB.

Copyright© 2011 ABB

All rights reserved

3KXA163687R1001

"Vario Pin" is a trademark of Interconnex AG