



# ABB

## The Company

We are an established world force in the design and manufacture of instrumentation for industrial process control, flow measurement, gas and liquid analysis and environmental applications.

As a part of ABB, a world leader in process automation technology, we offer customers application expertise, service and support worldwide.

We are committed to teamwork, high quality manufacturing, advanced technology and unrivalled service and support.

The quality, accuracy and performance of the Company's products result from over 100 years experience, combined with a continuous program of innovative design and development to incorporate the latest technology.

The UKAS Calibration Laboratory No. 0255 is just one of the ten flow calibration plants operated by the Company and is indicative of our dedication to quality and accuracy.

EN ISO 9001:2000



Cert. No. Q 05907

EN 29001 (ISO 9001)



Lenno, Italy – Cert. No. 9/90A

Stonehouse, U.K.



## Electrical Safety

This equipment complies with the requirements of CEI/IEC 61010-1:2001-2 'Safety Requirements for Electrical Equipment for Measurement, Control and Laboratory Use'. If the equipment is used in a manner NOT specified by the Company, the protection provided by the equipment may be impaired.

## Symbols

One or more of the following symbols may appear on the equipment labelling:

	<b>Warning</b> – Refer to the manual for instructions		Direct current supply only
	<b>Caution</b> – Risk of electric shock		Alternating current supply only
	Protective earth (ground) terminal		Both direct and alternating current supply
	Earth (ground) terminal		The equipment is protected through double insulation

Information in this manual is intended only to assist our customers in the efficient operation of our equipment. Use of this manual for any other purpose is specifically prohibited and its contents are not to be reproduced in full or part without prior approval of the Technical Publications Department.

### Health and Safety

To ensure that our products are safe and without risk to health, the following points must be noted:

1. The relevant sections of these instructions must be read carefully before proceeding.
2. Warning labels on containers and packages must be observed.
3. Installation, operation, maintenance and servicing must only be carried out by suitably trained personnel and in accordance with the information given.
4. Normal safety precautions must be taken to avoid the possibility of an accident occurring when operating in conditions of high pressure and/or temperature.
5. Chemicals must be stored away from heat, protected from temperature extremes and powders kept dry. Normal safe handling procedures must be used.
6. When disposing of chemicals ensure that no two chemicals are mixed.

Safety advice concerning the use of the equipment described in this manual or any relevant hazard data sheets (where applicable) may be obtained from the Company address on the back cover, together with servicing and spares information.

# Contents

<b>1 Introduction .....</b>	<b>3</b>	<b>4 Configuration .....</b>	<b>45</b>
<b>2 Operation .....</b>	<b>5</b>	4.1 Introduction .....	45
2.1 Powering up the Instrument .....	5	4.1.1 Configuration Level Security .....	45
2.2 Displays and Controls .....	5	4.1.2 Configuration Level Access .....	45
2.3 Chart Views .....	7	4.2 Overview of Configuration .....	48
2.3.1 Electronic Signatures .....	14	4.3 Making Changes to Parameters .....	49
2.4 Bargraph Views .....	15	4.4 Common Configuration .....	52
2.5 Digital Indicator View .....	17	4.4.1 Setup .....	52
2.6 Process View .....	20	4.4.2 Screen .....	53
2.7 Alarm Event Log .....	23	4.4.3 Time .....	54
2.8 Totalizer Log .....	25	4.4.4 Security .....	56
2.9 Audit Log .....	27	4.4.5 Users .....	58
2.10 Status View .....	28	4.4.6 Logs .....	60
		4.4.7 Operator Messages .....	60
<b>3 Setup .....</b>	<b>29</b>	4.5 Process Group Configuration .....	61
3.1 Introduction .....	29	4.5.1 Setting the Recording Parameters .....	61
3.2 Accessing the Setup Level .....	29	4.5.2 Configuring the Chart View .....	63
3.3 Password Entry .....	31	4.5.3 Configuring the Bargraph View .....	66
3.4 Setup Menu .....	32	4.5.4 Configuring the Process View .....	67
3.5 Archiving .....	34	4.5.5 Configuring the Digital Indicator View .....	68
3.5.1 Card Compatibility .....	34	4.5.6 Archiving .....	70
3.5.2 Media Status .....	34	4.6 Channel Configuration .....	72
3.5.3 Inserting and Removing Media .....	35	4.6.1 Recording Channel Setup .....	72
3.5.4 Archive File Types .....	36	4.6.2 Analog Input Configuration .....	74
3.6 Text Format Archive Files .....	37	4.6.3 Digital Input Configuration .....	77
3.6.1 Text Format Channel Data Files .....	37	4.6.4 Alarm Configuration .....	78
3.6.2 Text Format Filename Examples .....	38	4.6.5 Totalizer Configuration .....	84
3.6.3 Text Format Log files .....	38	4.7 Functions .....	87
3.6.4 Text Format Data File Examples .....	39	4.7.1 Custom Linearizers .....	87
3.6.5 Text Format Data File Digital Signatures .....	39	4.7.2 Real-time Alarms .....	88
3.6.6 Text Format Data Verification and Integrity .....	39	4.8 I/O Module Configuration .....	89
3.7 Binary Format Archive Files .....	41	4.8.1 Analog Inputs .....	89
3.7.1 Binary Format Archive Filenames .....	41	4.8.2 Relay Modules .....	90
3.7.2 Binary Format Channel Data Files .....	41	4.8.3 Ethernet Modules .....	90
3.7.3 Binary Format Log files .....	41	4.8.4 RS485 (Modbus™) Communications .....	91
3.7.4 Binary Format Data File Examples .....	41	4.8.5 Comms Analog Input .....	92
3.7.5 Binary Format Data Verification and Integrity .....	41	4.8.6 Comms Digital Input .....	93
		4.8.7 Hybrid Modules .....	94
3.8 Archiving Online/Offline .....	44	4.9 Modbus TCP .....	95
3.9 Backing-up Archived Data .....	44		
3.10 Archive Wrap .....	44		

<b>5 Installation</b> .....	<b>96</b>	<b>Appendix C – Storage Capacity</b> .....	<b>116</b>
5.1 Siting .....	96	C.1 Internal Storage Capacity .....	116
5.2 Mounting .....	97	C.2 Archive Storage Capacity .....	117
5.3 Electrical Connections .....	98	<b>Appendix D – Default Settings</b> .....	<b>119</b>
5.4 Analog Inputs .....	100	D.1 Company Standard .....	119
5.4.1 Current and Voltage .....	100	D.1.1 Common Configuration .....	119
5.4.2 Thermocouple .....	100	D.1.2 Process Groups 1 to 6 .....	119
5.4.3 Resistance Thermometer (RTD) .....	100	D.1.3 Recording Channels .....	120
5.4.4 Transmitter Power Supply .....	100	D.1.4 I/O Modules .....	120
5.5 RS422/485 Serial Communications .....	101	D.1.5 Functions .....	121
5.6 Mains Power Connections .....	102	D.2 QuickStart Templates .....	121
5.7 Relay Output Board Connections .....	102	D.2.1 QSMilliAmp .....	121
5.8 Hybrid I/O Module Connections .....	103	D.2.2 QSFlow .....	121
5.8.1 Digital Output Connections .....	103	D.2.3 QSTHC_C .....	121
5.8.2 Digital Input Connections .....	103	D.2.4 QSTHC_F .....	121
5.8.3 Analog Output Connections .....	103	D.2.5 QSRTD_C .....	121
<b>Appendix A – Signal Sources</b> .....	<b>104</b>	D.2.6 QSRTD_F .....	121
<b>Appendix B – Modbus Guide</b> .....	<b>106</b>	D.2.7 QSDEMO .....	122
B.1 Introduction .....	106	D.2.8 QSDAIRY .....	123
B.2 Setting Up .....	106	<b>Appendix E – Spare Parts and Accessories</b> .....	<b>124</b>
B.3 Modbus Commands Supported .....	106	<b>Appendix F – Error &amp; Diagnostics Information</b> .....	<b>126</b>
B.4 Modbus Exception Responses .....	106	<b>Appendix G – Symbols and Icons</b> .....	<b>127</b>
B.5 Operating Mode Modbus Coils .....	106	<b>Index</b> .....	<b>128</b>
B.6 Operating Mode Modbus Registers .....	112		
B.7 Comms. Analog and Digital Inputs .....	114		

# 1 Introduction

## Functional Overview – Fig. 1.1

- 12 Recording Channels as standard, divided into 2 Process Groups, each with 6 Recording Channels.
- Two Alarms and one Totalizer (if Totalizer option is enabled) are assigned to each Recording Channel.
- Signal sources derived from universal analog inputs, the Modbus serial link, optional digital inputs or internal analog and digital signals.
- Any source can be assigned to any recording channel.
- Data from assigned sources can be displayed in:
  - Vertical or Horizontal Chart view format
  - Vertical or Horizontal Bargraph view format
  - Digital Indicator view format
  - Process view format
- Three instrument logs record alarm events, totalizer values (if totalizer option is enabled) and system/configuration changes.
- Screen Capture facility – saves an image of any of the operator views to external archive media provided external archive media with sufficient free space is inserted in the instrument. It is not necessary for archiving to be 'online'.

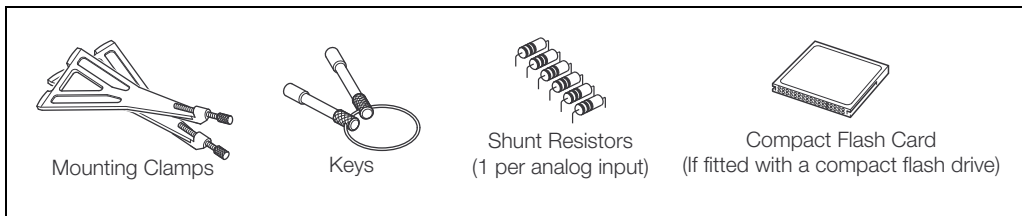

**Standard Accessories**

**Note.** For optional accessories, refer to Appendix E on page 124.

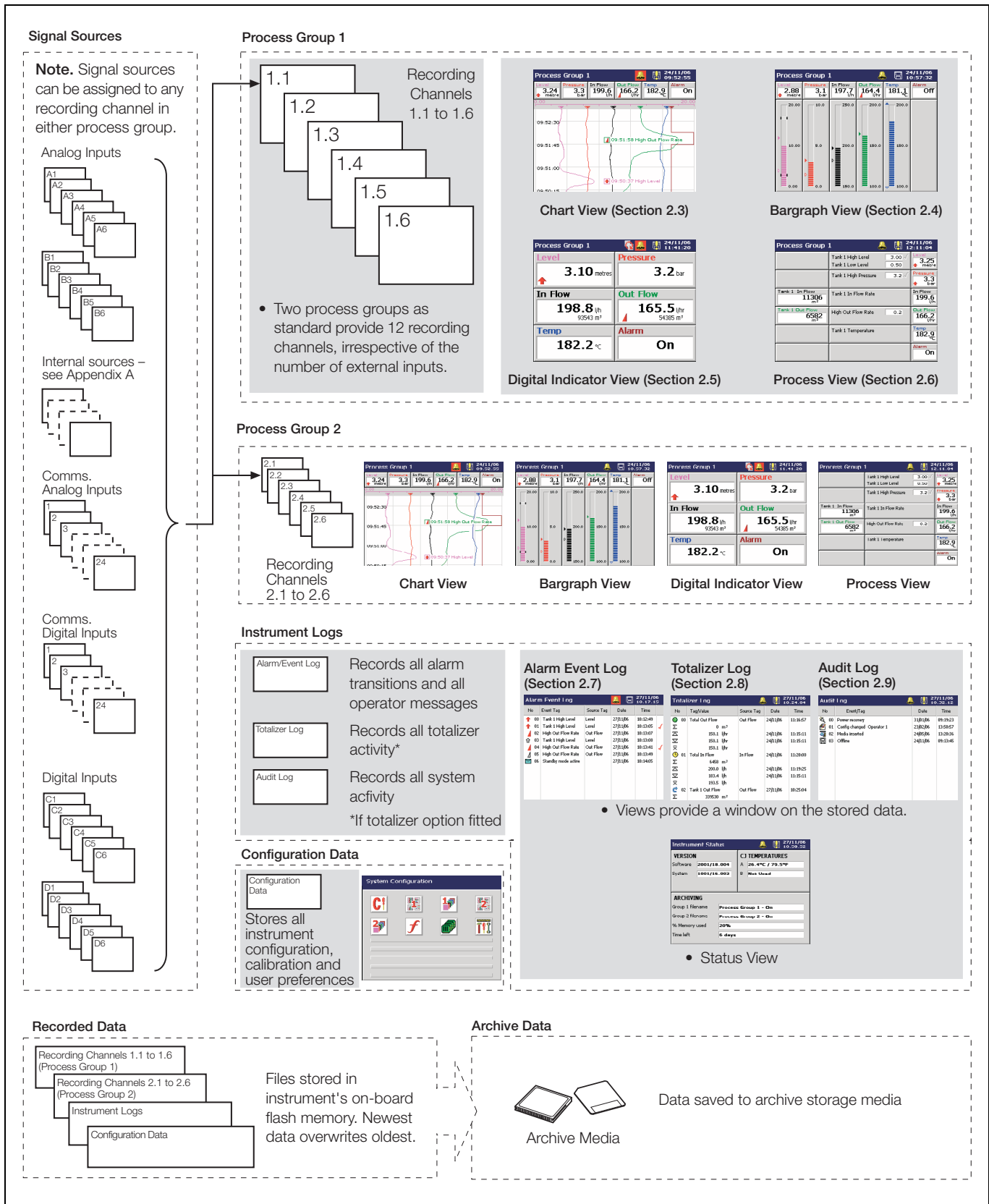

Fig. 1.1 Functional Overview

## 2 Operation

### 2.1 Powering up the Instrument

When power is first applied to the instrument, its processor carries out a number of self-tests and displays the start-up screen.

At the end of the start-up sequence the instrument displays the Operator View that was being displayed when the instrument was powered down.

### 2.2 Displays and Controls – Figs. 2.1 and 2.2

In normal day-to-day use, the instrument is operated via the Operator Keys located along the bottom of the screen.

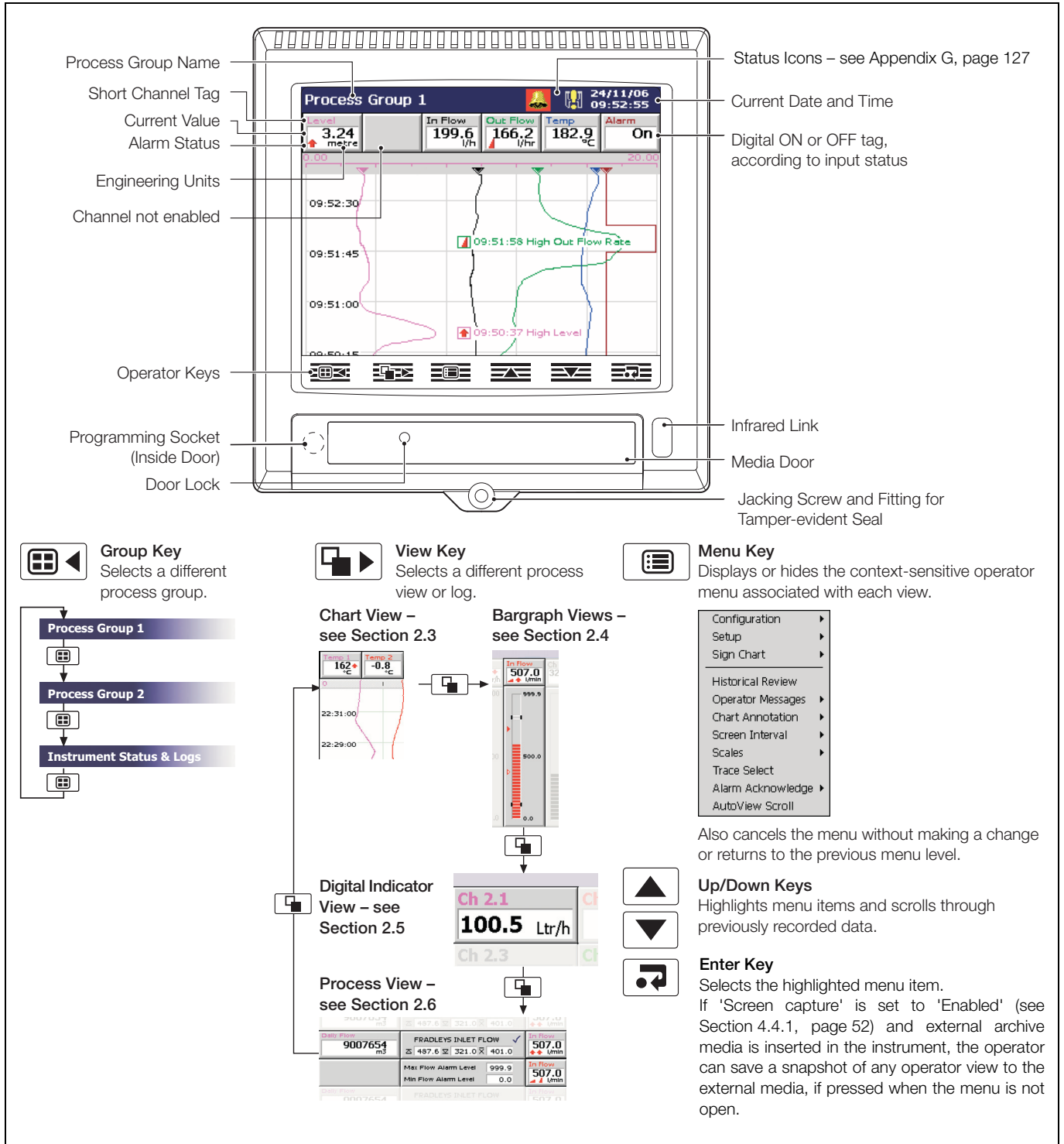

Fig. 2.1 Displays and Controls

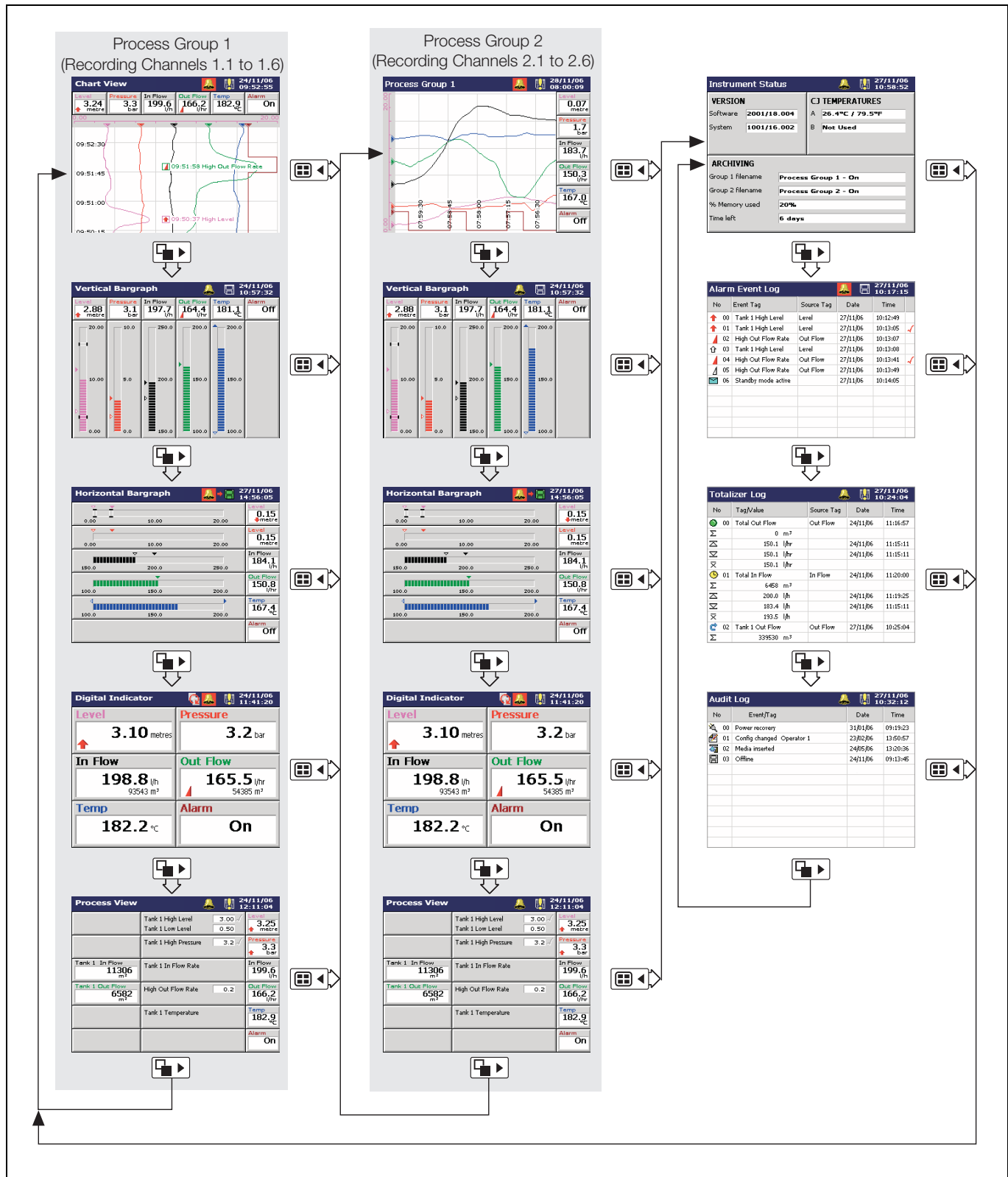

Fig. 2.2 Overview of Operator Displays

**Note.** Only process groups and views that have been enabled are displayed – see Section 4.5, page 61.

2.3 Chart Views – Fig. 2.3

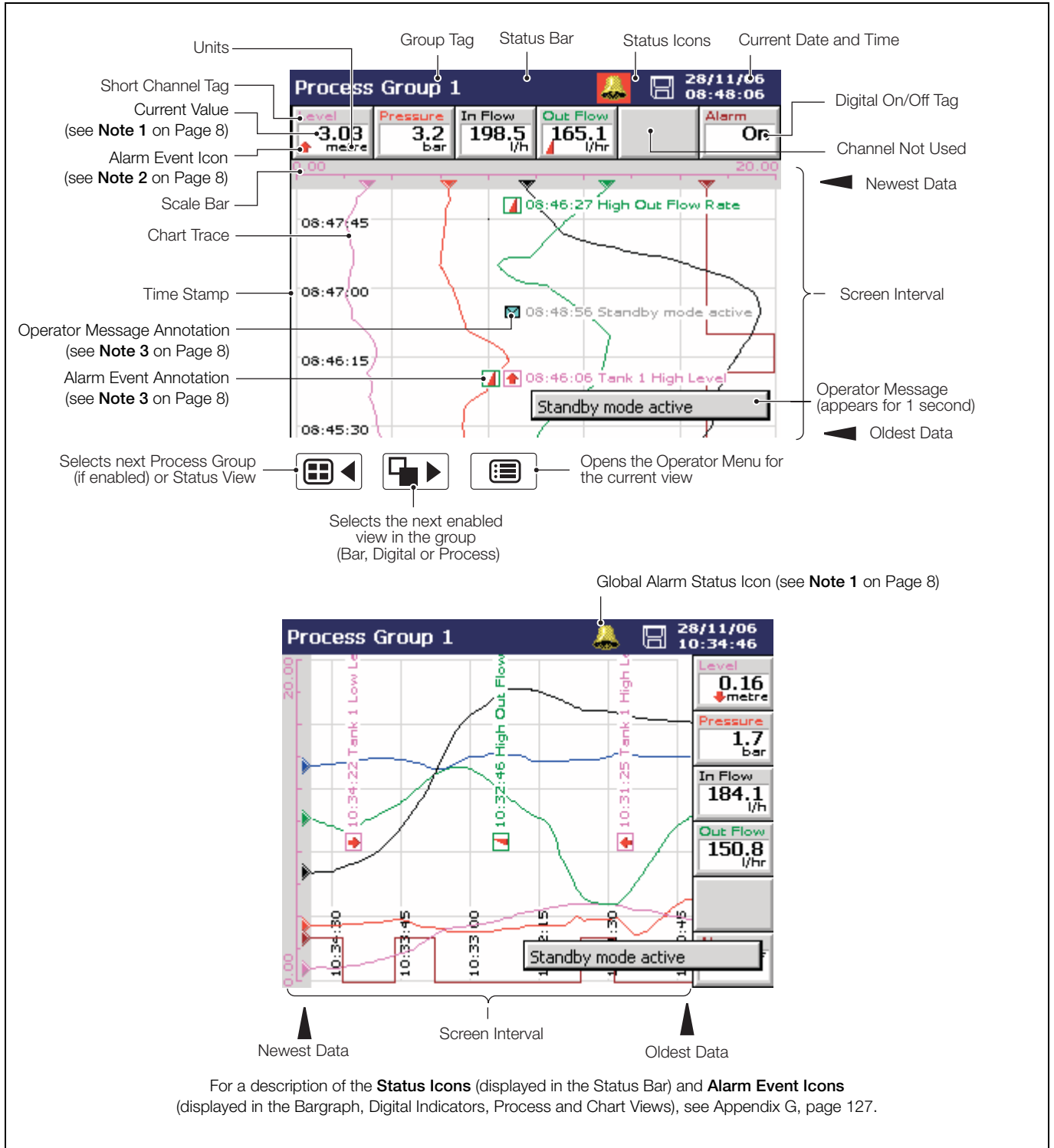

Fig. 2.3 Horizontal and Vertical Chart Views

**Note.** Do not remove media while either of the media update in progress status icons (🔴➡️ or 🔴➡️) are displayed.

**Note.**

**1. Current Values**



The Current Value, shown on the digital indicators at either the top (vertical chart view) or right hand side (horizontal chart view) of the screen, is the latest instantaneous value and its update rate is not affected by the recording sample rate.

If the current value in the digital indicator is displayed in red, recording has been stopped for that channel – see Section 3.4, page 32 and see Section 4.6.1, page 72.

Traces are shown only when that particular channel is being recorded. When a channel is set to **Stop**, its trace continues to be shown for up to one sample period.

**2. Alarm Status**



- Flashing red alarm event icon – alarm active and unacknowledged
- Continuous red alarm event icon – alarm active and acknowledged

If **any** alarm in **any** process group is active, the Global Alarm status icon () is displayed in the status bar – see Fig. 2.3. If **any** active alarm in **any** process group is unacknowledged, the icon is surrounded by a red flashing border ()

**3. Alarm Event and Operator Message Annotations**

Alarm Event and Operator Message annotations are not shown on the chart unless enabled – see 'Chart Annotation' on page 11 and see Section 4.5.2, page 63.

If Alarm event annotation is enabled and an alarm becomes active, a red alarm event icon surrounded by a channel colored box is displayed at the point at which the alarm occurred, together with the alarm time and tag, e.g.

   11:58:00 1.1A High Level

If more than one alarm occurs in the same sample period:

- and the second alarm on a channel becomes active, its icon is added behind the first.
- and more than one operator message is active (max. six), a second icon is added behind the first.
- the new alarm event icons appear to the left of earlier icons.
- the time and tag of the oldest alarm (right-most icon) only is displayed.

**4. Screen Capture**

If 'Screen capture' is set to 'Enabled' in Common Configuration (see Section 4.4.1, page 52) **and** an external archive media card is inserted in the instrument, an image of any Chart, Bargraph, Digital Indicator, Process, Instrument Status, Audit Log, Alarm Log or Totalizer Log view can be saved to the external media by pressing the  key whenever the Operator Menu is not open.



- Configuration ▶
- Setup ▶
- Sign Chart ▶
  
  
- Historical Review

---

Select the Configuration Level – see Section 4, page 45.

---

Select the Setup Level – see Section 3, page 29.

---

**Note.** Available only if 'Security system' is set to 'Advanced' – see Section 4.4.4, page 56.  
Sign the chart electronically – see Section 2.3.1, page 14.

---

Select Historical Review to view previously recorded data stored in the instrument's onboard memory.

**Note.** Use the ▲ and ▼ keys to move backwards and forwards through the recorded data.

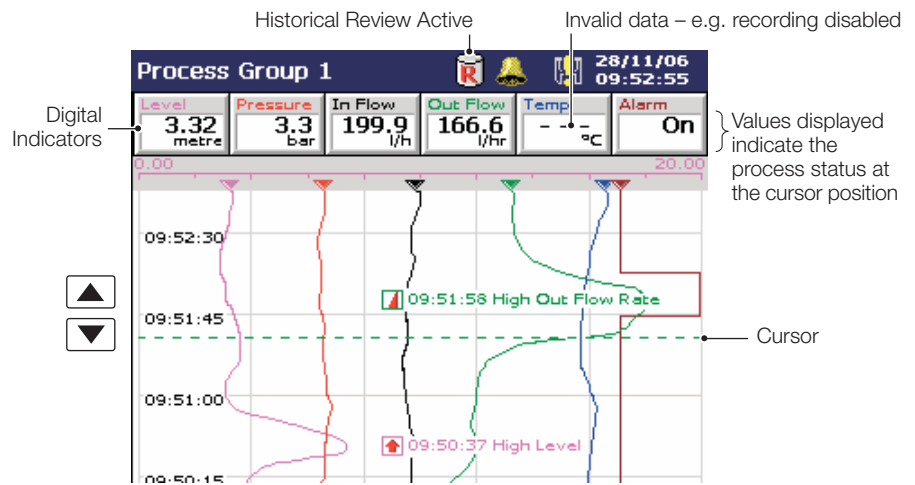

**Note.**

While in Historical Review mode:

- Recording of new data continues unless stopped from the Setup Menu – see Section 3.4, page 32.
- Invalid historical data (e.g. when recording has stopped) is denoted by '– –' in the digital indicator.
- Where the trace at the cursor position represents more than one sample, the indicators flash between the maximum and minimum values of those samples.
- Menu options remain active – allowing the screen interval to be changed, different scales and channels to be selected, etc.
- Operator messages generated are added to the alarm event log at the present time, not the time indicated by the cursor.
- All data stored in the instrument's internal memory can be viewed.
- The display can be scrolled back to the start of the oldest data.
- Archiving to removable media does not occur but all data recorded in the internal memory buffer during this time is archived on exiting Historical Review mode.

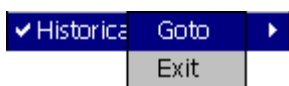

Select 'Goto' to move to data stored in the instrument's onboard memory that was recorded at a specific date and time.

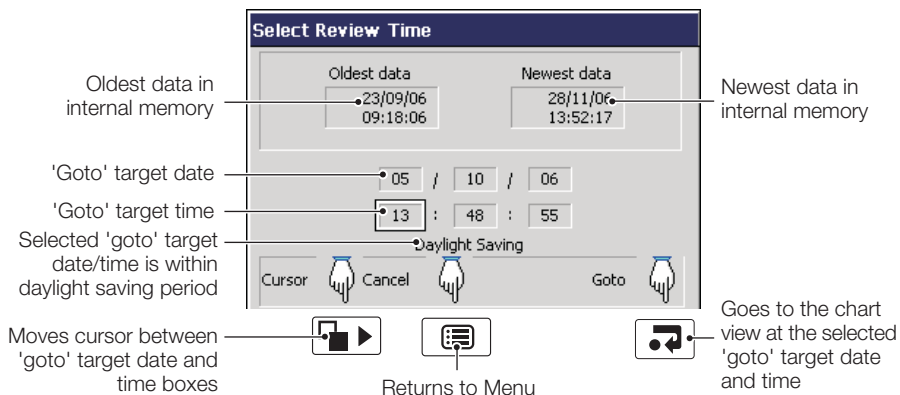

**Note.**

- If daylight saving is enabled (see Section 4.4.3, page 54) **and** the selected 'Goto' target date/time is within the daylight saving period, 'Daylight Saving' is displayed on the dialog box.
- Once internal memory becomes full, oldest data is overwritten by newest data. If historical review has been selected for some time, the oldest data present may no longer be available.
- The instrument exits Historical Review mode automatically after 15 minutes if no key is pressed.



Select Exit to return to the real-time recording display.

**Note.** Pressing the  key also exits Historical Review mode and displays the next enabled view.

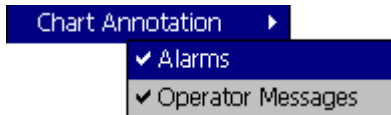
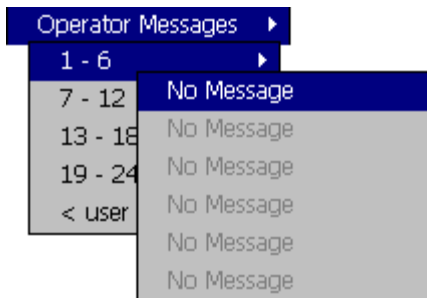

Add one of 24 predefined Operator Messages (see Section 4.4.7, page 60) or one User-Defined Message to the alarm event log.

If '< user defined >' is selected, a data entry keyboard appears to enable the message to be entered (see Fig. 4.6, page 50).

The selected or user-defined message is displayed briefly on screen. If Operator Message annotation is selected (see 'Chart Annotation' below) the message is also added to the chart.

**Note.** When the instrument is in Historical Review mode, Operator Messages generated are added at the current time, not the time indicated by the cursor.

If an alarm or operator message is obscuring part of a chart trace, use the Chart Annotation option to hide or display alarms and messages on the screen. Select the annotation required. ✓ indicates the annotations selected.

The possible combinations are:

- No annotation (Alarms and Operator Messages both disabled)
- Alarm annotation only
- Alarms and Operator Message annotation

Operator Message annotation cannot be enabled unless Alarm annotation is also enabled.

**Note.**

- If more than 15 icons are present on the screen, chart annotation is disabled automatically.
- When chart annotation is disabled, new operator messages and alarms are still added to the Alarm Event log – see Section 2.7, page 23.

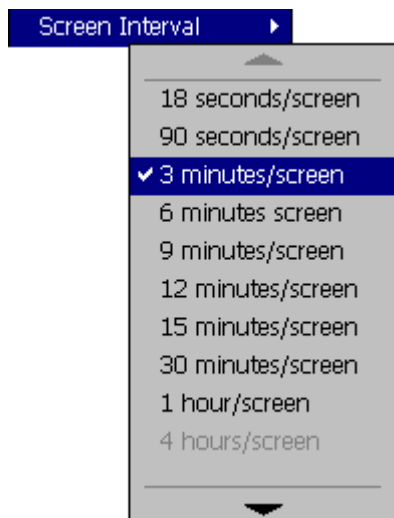

Use the 'Screen Interval' to change the amount of data displayed on the screen. A longer screen interval displays more data, a shorter screen interval displays data over a shorter time period, but in more detail. In both cases, the full trace is preserved by plotting the maximum and minimum samples for each display point.

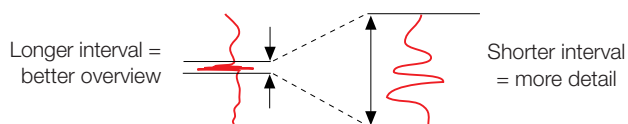

The screen intervals available in the menu are determined by the faster of the primary and secondary sample rates set for the process group during configuration – see Section 4.5.1, page 61. Unavailable screen intervals are greyed-out.

Table 2.1 shows the relationship between sample rate and screen interval for the Vertical and Horizontal Chart views.

**Note.**

- A 'Please Wait' message appears in the status bar while the instrument retrieves data from storage.
- Selecting a different screen interval does not affect the rate at which data is sampled.
- When in historical review mode, changing the screen interval causes the time at the cursor position to change.

Sample Rate Setting	Maximum Screen Interval	
	Vertical Chart View	horizontal Chart View
<1 second	Up to 9 minutes/screen	Up to 13 minutes/screen
Between 1 and 10 seconds	Up to 1 hour/screen	Up to 1.5 hours/screen
More than 10 seconds, less than 20 seconds	Up to 12 hours/screen	Up to 18 hours/screen
Between 20 and 40 seconds	Up to 1 day/screen	Up to 1.5 days/screen
Between 40 and 60 seconds	Up to 2 days/screen	Up to 3 days/screen
More than 60 seconds, less than 140 seconds	Up to 3 days/screen	Up to 4.5 days/screen
More than 140 seconds	Up to 7 days/screen	Up to 10 days/screen

Table 2.1 Sample Rates and Screen Intervals

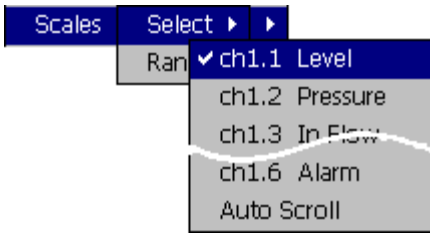

Select a channel scale to be displayed in the scale bar at the top of the chart window. For digital channels, the On and Off tags are displayed at the corresponding position on the scale bar.

Select 'Auto Scroll' to display the scale for each enabled channel in turn for 36 seconds.

Trace Select

Hide individual channel traces to improve chart clarity.

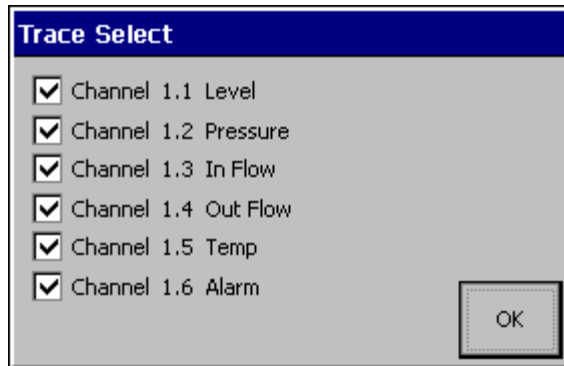

Traces are identified by the Channel Number (e.g. Ch1.1) and its short tag.

**Note.** The recording of a channel's data is not affected by this operation and the instantaneous channel values are still shown on the indicators at the top of the screen.

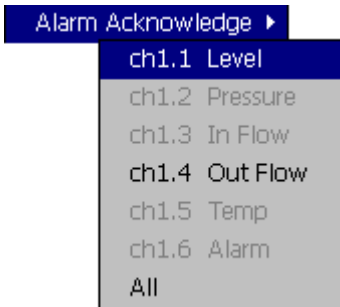

To acknowledge a particular alarm, use the ▲ and ▼ keys to highlight it in the menu and press the key.

**Note.** Active unacknowledged alarms in the current process group are identified by a flashing red Alarm Event icon in the bottom left hand corner of the associated channel indicator. Active acknowledged alarms are identified by a continuous red Alarm Event icon in the bottom left hand corner of the indicator – see Fig. 2.3, page 7.

To acknowledge all active alarms in the current process group simultaneously, select 'All' and press the key.

**Note.** If an alarm in **the other** process group is active, the Global Alarm status icon () continues to be displayed in the status bar. If an active alarm in **the other** process group is unacknowledged, the icon is surrounded by a red flashing border ().

If neither alarm on a particular channel is configured, the short channel tag is shown greyed-out in the menu.

AutoView Scroll

Select 'AutoView Scroll' to display the chart for each configured process group in turn for 40 seconds. The AutoView Scroll status icon () is displayed in the status bar when AutoView Scroll is active. Press any key to cancel AutoView Scroll.

### 2.3.1 Electronic Signatures – Fig. 2.4

Entering an electronic signature is the equivalent to signing the chart of a conventional paper recorder. Local procedures may require the approval of a record by an authorized signatory; for this reason, an electronic signature is password protected.

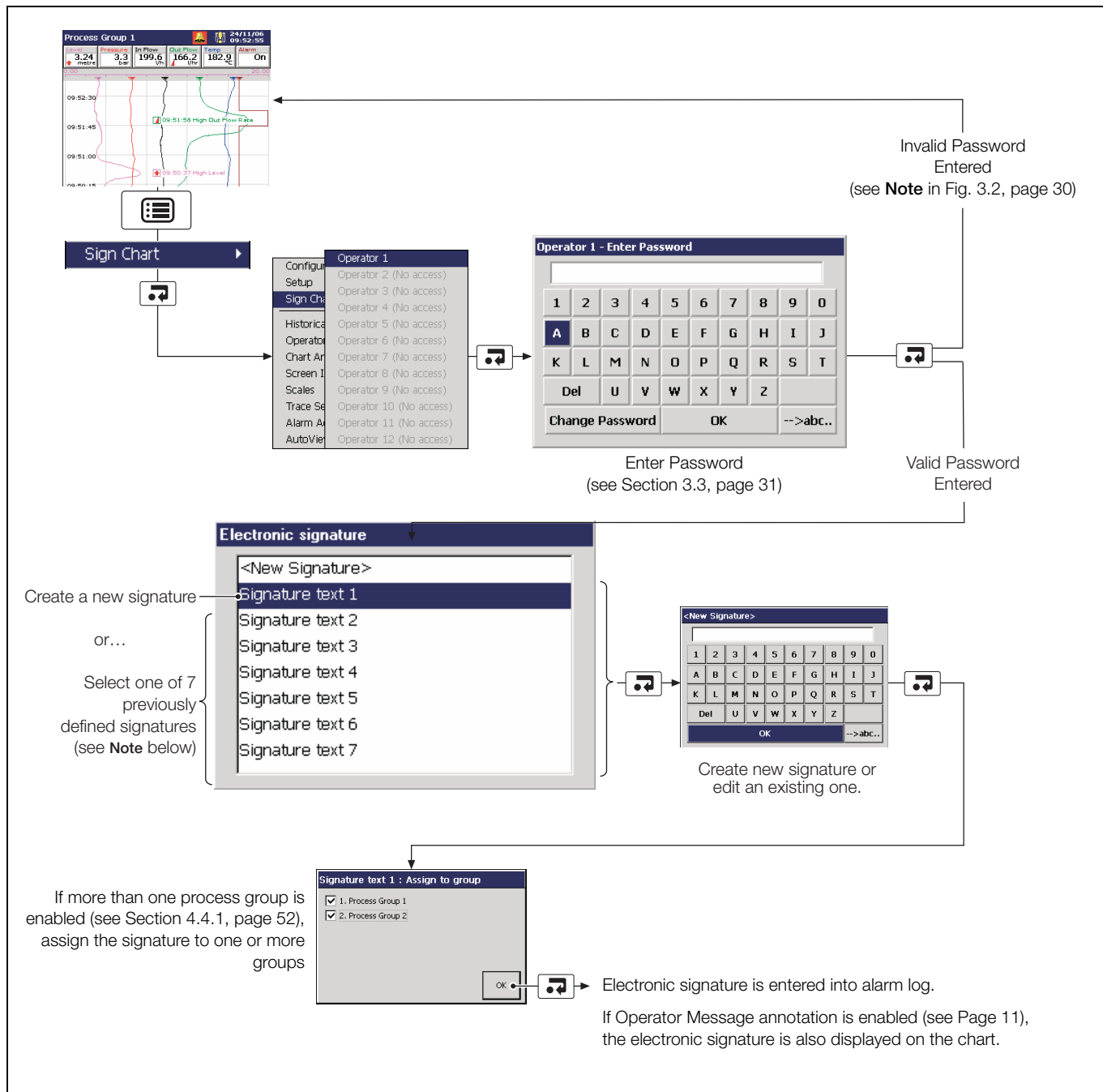

Fig. 2.4 Entering an Electronic Signature

**Note.** Up to 7 electronic signatures can be stored in the instrument's memory. If 7 signatures exist and a new one is created, the oldest is overwritten.

2.4 Bargraph Views – Fig. 2.5

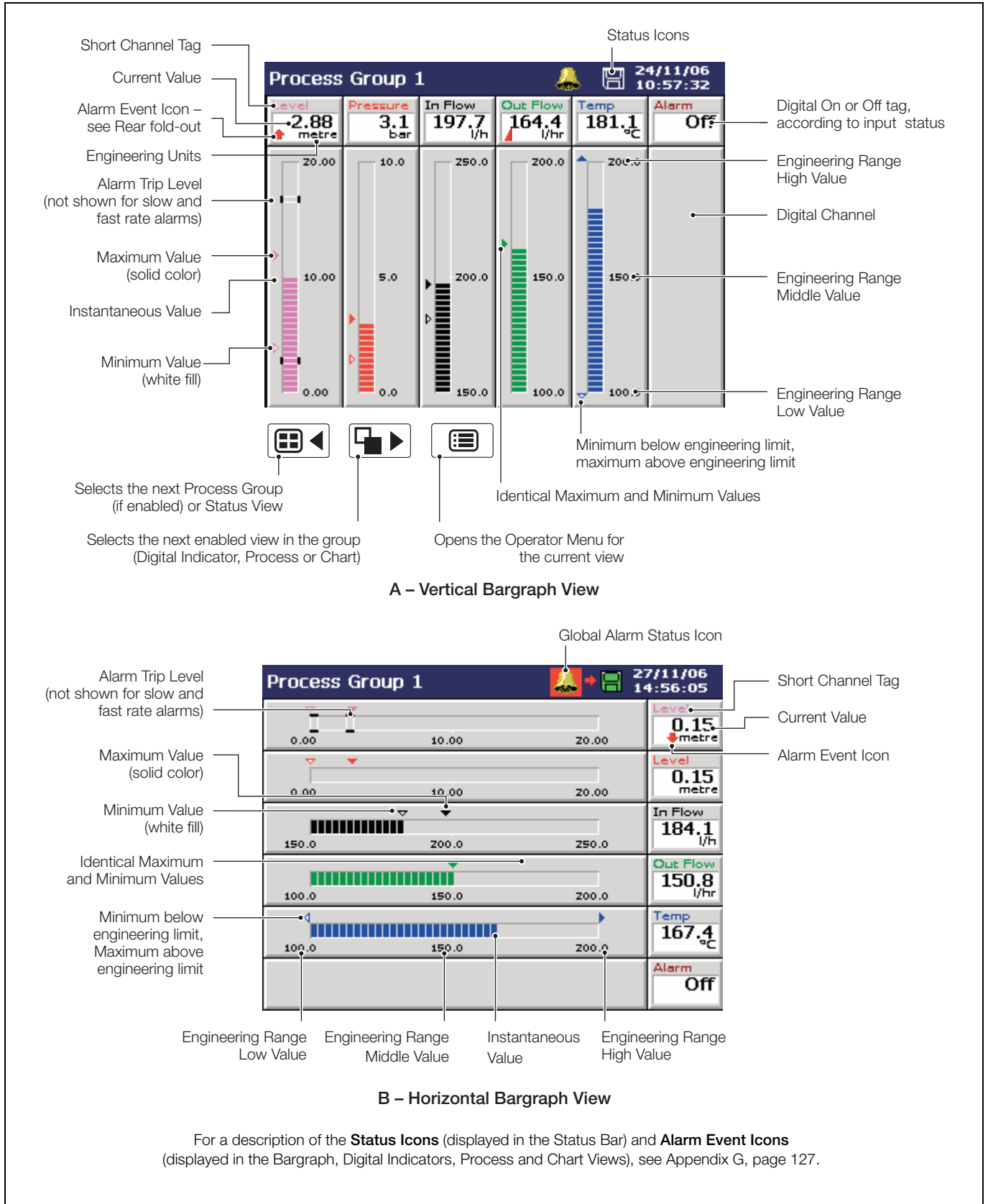

Fig. 2.5 Bargraph Views



Configuration ▶

Select the Configuration Level – see Section 4, page 45.

Setup ▶

Select the Setup Level – see Section 3, page 29.

Operator Messages ▶

Add one of 24 predefined Operator Messages (see Section 4.4.7, page 60) or one User-Defined Message to the alarm event log.

1 - 6 ▶

7 - 12 No Message

13 - 18 No Message

19 - 24 No Message

< user No Message

No Message

No Message

If '< user defined >' is selected, a data entry keyboard appears to enable the message to be entered (see Fig. 4.6, page 50). The selected or user-defined message is displayed briefly on-screen.

Max/Min Reset ▶

Reset the Maximum and Minimum value markers on one or all channels to the current value.

ch1.1 Level

ch1.2 Pressure

ch1.3 In Flow

ch1.4 Out Flow

ch1.5 Temp

ch1.6 Alarm

All

**Note.**

- These Maximum and Minimum values are for display purposes only. They are not saved or archived and are not connected to the Totalizer Maximum and Minimum Values displayed in the Process View.
- These Maximum and Minimum values are reset whenever the current configuration has been changed or is re-saved.

Alarm Acknowledge ▶

To acknowledge a particular alarm, use the ▲ and ▼ keys to highlight it in the menu and press the [OK] key.

ch1.1 Level

ch1.2 Pressure

ch1.3 In Flow

ch1.4 Out Flow

ch1.5 Temp

ch1.6 Alarm

All

**Note.** Active unacknowledged alarms in the current process group are identified by a flashing red Alarm Event icon in the bottom left hand corner of the associated indicator. Active acknowledged alarms are identified by a continuous red Alarm Event icon in the bottom left hand corner of the indicator – see Fig. 2.5, page 15.

To acknowledge all active alarms in the current process group simultaneously, select 'All' and press the [OK] key.

**Note.** If an alarm in the **other** process group is active, the Global Alarm status icon (🚨) continues to be displayed in the status bar. If an active alarm in the **other** process group is unacknowledged, the icon is surrounded by a red flashing border (🚨).

If neither alarm on a particular channel is configured, the short channel tag is shown greyed-out in the menu.

AutoView Scroll

Select 'AutoView Scroll' to display the bargraph for each configured process group in turn for 40 seconds. The AutoView Scroll status icon (🔄) is displayed in the status bar when AutoView Scroll is active. Press any key to cancel AutoView Scroll.

2.5 Digital Indicator View – Fig. 2.6

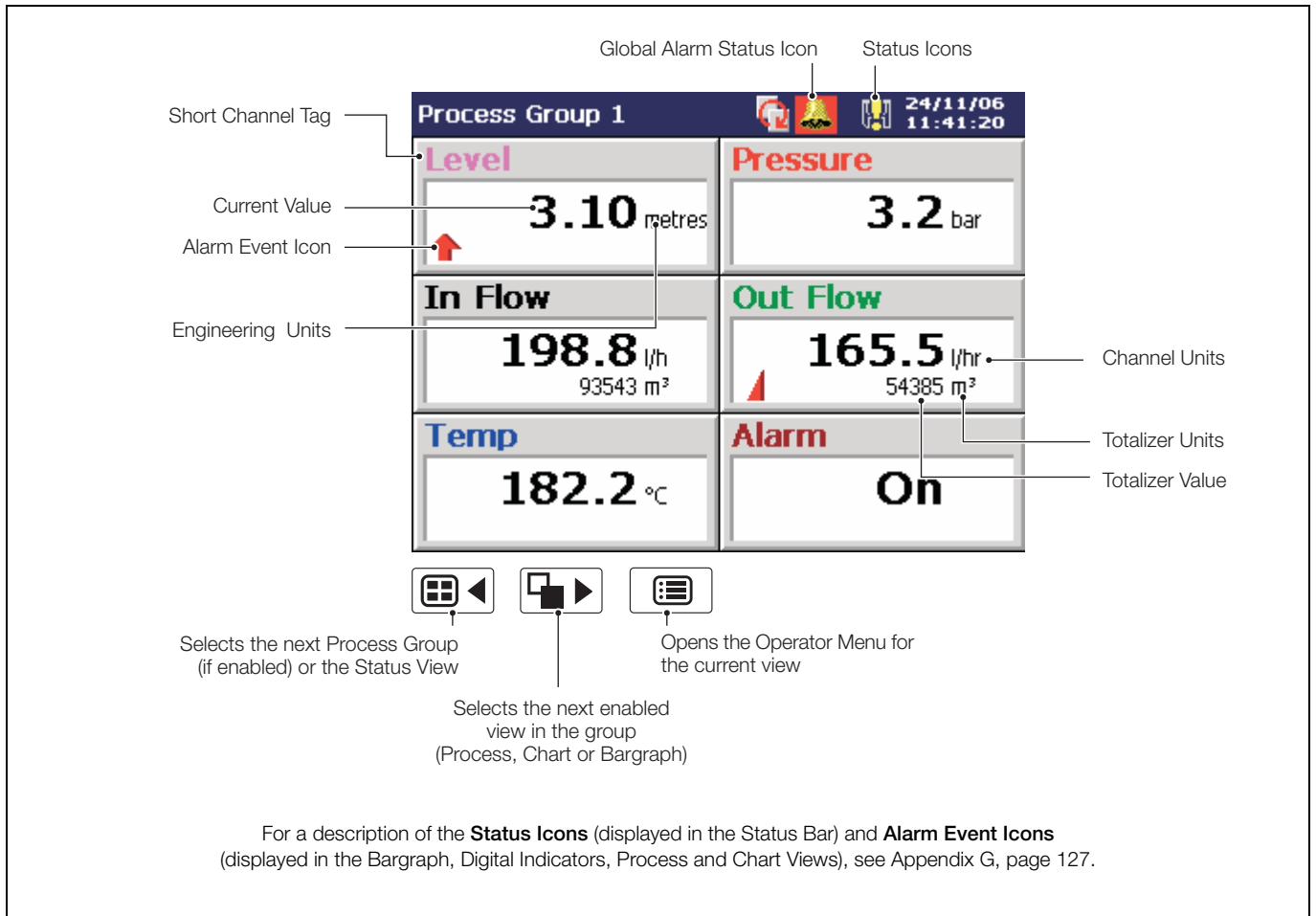

Fig. 2.6 Digital Indicator View

**Note.**

- Digital indicators resize automatically according to the number of channels displayed.
- The totalizer option must be enabled and totalizers configured and enabled in the Configuration level before they are displayed – see Section 4.6.5, page 84.
- When a totalizer is not running (i.e. 'Stop' is selected), the corresponding totalizer value is shown in red.



Configuration ▶

Setup ▶

Operator Messages ▶

- 1 - 6 ▶
- 7 - 12 No Message
- 13 - 18 No Message
- 19 - 24 No Message
- < user No Message
- No Message
- No Message

Channel Select

Select the Configuration Level – see Section 4, page 45.

Select the Setup Level – see Section 3, page 29.

Add one of 24 predefined Operator Messages (see Section 4.4.7, page 60) or one User-Defined Message to the alarm event log.

If '< user defined >' is selected, a data entry keyboard appears to enable the message to be entered (see Fig. 4.6, page 50). The selected or user-defined message is displayed briefly on-screen.

Hide or display individual channel indicators for the group currently displayed.

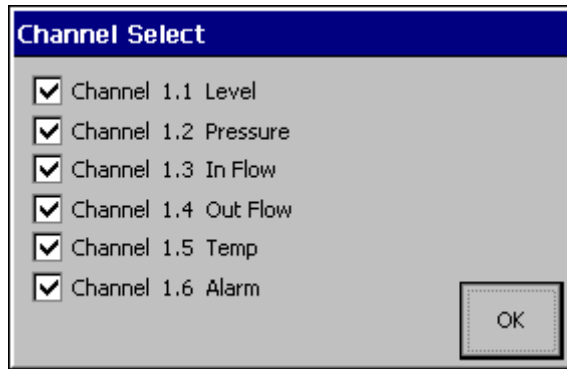

**Note.**

- The digital indicators displayed are sized equally depending on the number of channels selected. This has no effect on the recording of the channel.
- Channels that have not been configured are greyed-out in the menu.

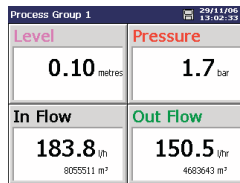

Three or Four Channels Selected

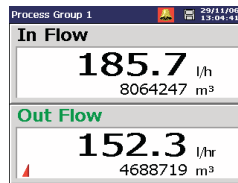

Two Channels Selected

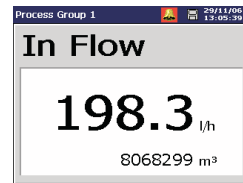

One Channel Selected

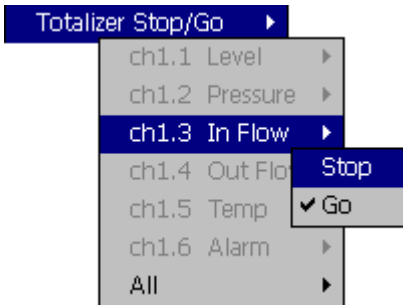

Stop and start individual totalizers.

Channel totalizers that have not been enabled in the Configuration level are greyed-out.

**Note.**

- Displayed only if the Totalizer option is enabled.
- When a totalizer is not running (i.e. 'Stop' is selected), the corresponding totalizer value is shown in red.

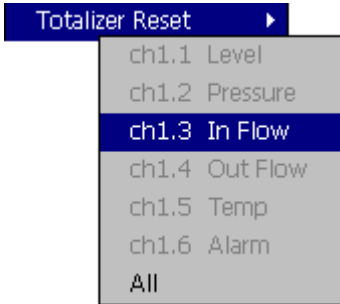

Reset the totalizer value to the totalizer preset value.

Channel totalizers that have not been enabled in the Configuration level are greyed-out.

**Note.** Displayed only if the Totalizer option is enabled.

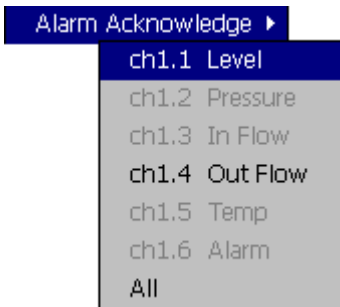

To acknowledge a particular alarm, use the and keys to highlight it in the menu and press the key.

**Note.** Active unacknowledged alarms in the current process group are identified by a flashing red Alarm Event icon in the bottom left hand corner of the associated indicator. Active acknowledged alarms are identified by a continuous red Alarm Event icon in the bottom left hand corner of the indicator – see Fig. 2.6, page 17.

To acknowledge all active alarms in the current process group simultaneously, select 'All' and press the key.

**Note.** If an alarm in **the other** process group is active, the Global Alarm status icon continues to be displayed in the status bar. If an active alarm in **the other** process group is unacknowledged, the icon is surrounded by a red flashing border .

If neither alarm on a particular channel is configured, the short channel tag is shown greyed-out in the menu.



Select 'AutoView Scroll' to display the digital indicator for each configured process group in turn for 40 seconds. The AutoView Scroll status icon is displayed in the status bar when AutoView Scroll is active. Press any key to cancel AutoView Scroll.

2.6 Process View – Fig. 2.7

**Note.** The Process view is available only if the Totalizer option is enabled.

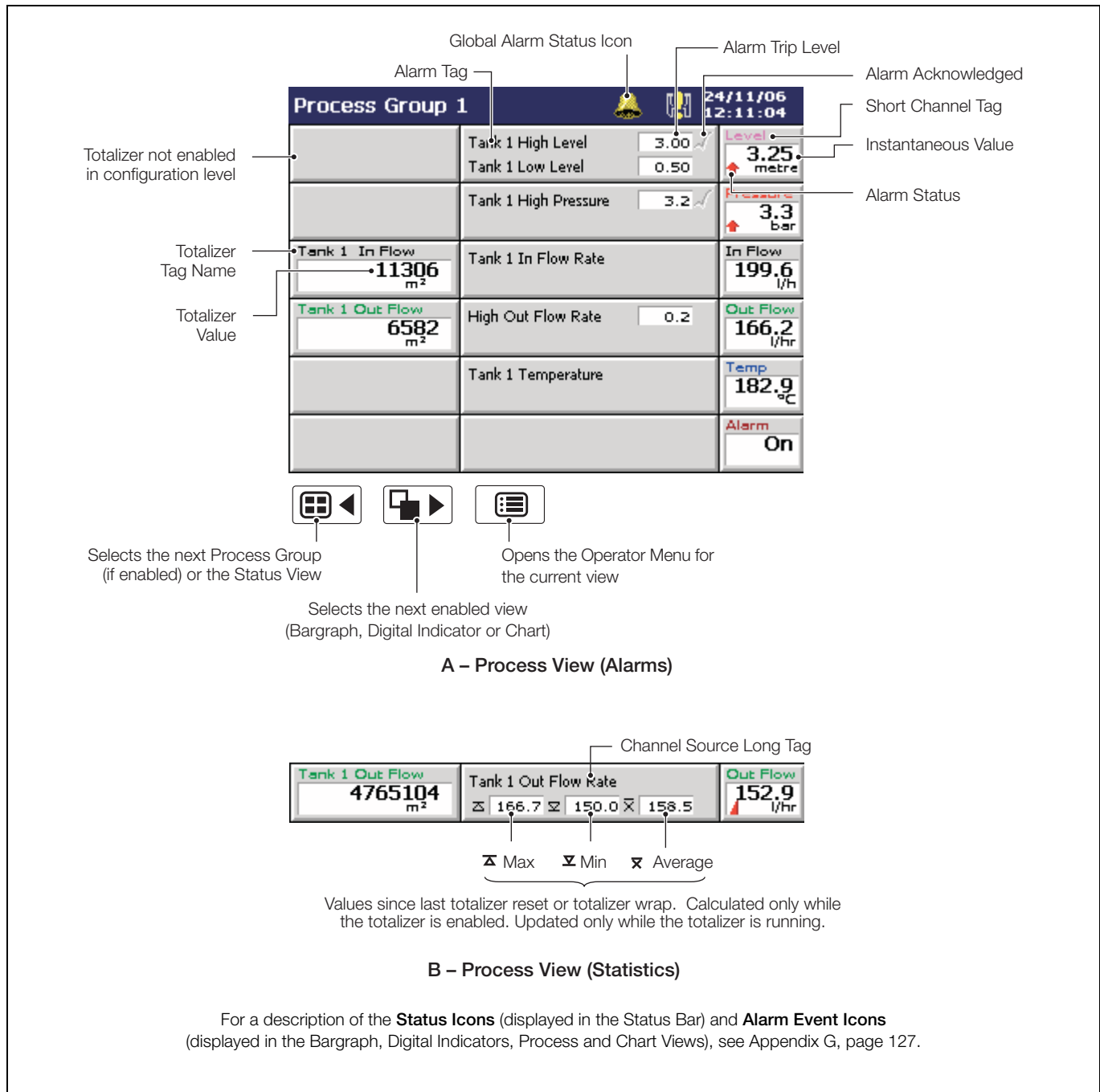

Fig. 2.7 Process View

**Note.**

- Only totalizers that have been configured and enabled in the Configuration level are displayed.
- When a totalizer is not running (i.e. 'Stop' is selected), the corresponding totalizer value is shown in red.



Configuration ▶

Select the Configuration Level – see Section 4, page 45.

Setup ▶

Select the Setup Level – see Section 3, page 29.

View Select ▶

✓ Alarms  
Stats

Switch between the Alarm View and the Statistics View.

**Note.** If a channel's totalizer is not enabled in the Configuration level, Alarm trip levels are shown in place of the channel statistics. If no alarms are enabled, the long tag for that channel is displayed.

Operator Messages ▶

1 - 6 ▶  
7 - 12 No Message  
13 - 18 No Message  
19 - 24 No Message  
< user No Message  
No Message  
No Message

Add one of 24 predefined Operator Messages (see Section 4.4.7, page 60) or one User-Defined Message to the alarm event log.

If '< user defined >' is selected, a data entry keyboard appears to enable the message to be entered (see Fig. 4.6, page 50). The selected or user-defined message is displayed briefly on-screen.

Totalizer Stop/Go ▶

ch1.1 Level ▶  
ch1.2 Pressure ▶  
ch1.3 In Flow ▶  
ch1.4 Out Flo Stop  
ch1.5 Temp ✓ Go  
ch1.6 Alarm ▶  
All ▶

Stop and start individual totalizers.

Channel totalizers that have not been enabled in the Configuration level are greyed-out.

**Note.** When a totalizer is not running (i.e. 'Stop' is selected), the corresponding totalizer value is shown in red.

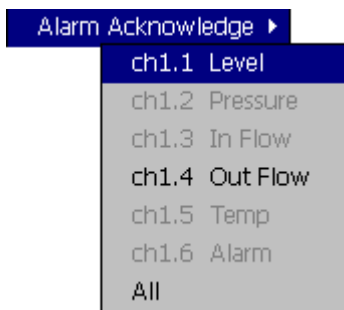
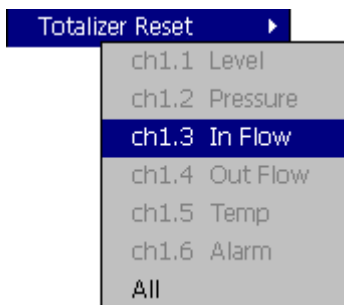

---

Reset the totalizer value to the totalizer preset value.



Channel totalizers that have not been enabled in the Configuration level are greyed-out.

---

To acknowledge a particular alarm, use the  and  keys to highlight it in the menu and press the  key.

**Note.** Active unacknowledged alarms in the current process group are identified by a flashing red Alarm Event icon in the bottom left hand corner of the associated indicator. Active acknowledged alarms are identified by a continuous red Alarm Event icon in the bottom left hand corner of the indicator – see Fig. 2.6, page 17.

To acknowledge all active alarms in the current process group simultaneously, select 'All' and press the  key.

**Note.** If an alarm in **the other** process group is active, the Global Alarm status icon  continues to be displayed in the status bar. If an active alarm in **the other** process group is unacknowledged, the icon is surrounded by a red flashing border .

If neither alarm on a particular channel is configured, the short channel tag is shown greyed-out in the menu.

---

Select 'AutoView Scroll' to display the process view for each configured process group in turn for 40 seconds. The AutoView Scroll status icon  is displayed in the status bar when AutoView Scroll is active. Press any key to cancel AutoView Scroll.

2.7 Alarm Event Log – Fig. 2.8

**Note.** The Alarm Event log view provides an historical log of all alarm events in the sequence in which they occurred. To view the current status of all alarms, choose the Process View – see Section 2.6, page 20.

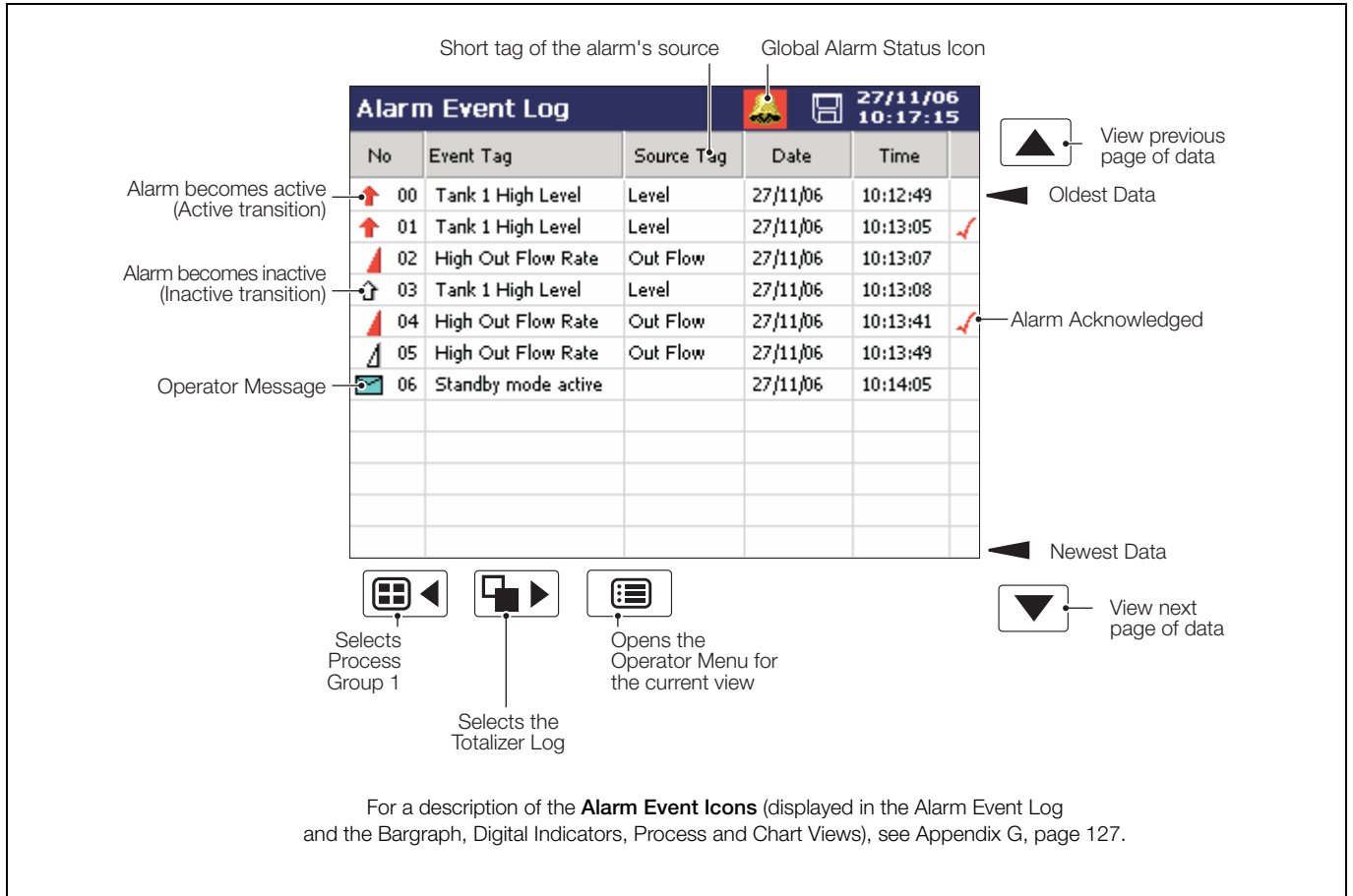

Fig. 2.8 Alarm Event Log

**Note.** When the number of entries in the Alarm Event log has reached that defined in 'Alarm log size' (see Section 4.4.6, page 60), the oldest data is overwritten by the newest. Entries are renumbered so that the number of the oldest entry is always 00.



Configuration ▶

Setup ▶

Filter ▶

- ✓ Group 1 Alarms
- Group 2 Alarms
- ✓ Operator Messages
- Active Transitions Only

---

Select the Configuration Level – see Section 4, page 45.

---

Select the Setup Level – see Section 3, page 29.

---

Select the entries to be displayed in the log. ✓ Indicates entries currently displayed.

**Note.**

- Hiding and displaying log entries does not affect the recording of events in the log.
- All selected alarm event transitions (from inactive to active, from active to acknowledged, from acknowledged to inactive, from active to inactive) appear in the sequence in which they occurred.
- Selecting 'Active Transitions Only' displays entries for alarms when made active and hides all acknowledged & inactive transitions.

Alarm Acknowledge ▶

Group 1 Alarms ▶

- Group 1 Alarms
- ch1.1 Level
- ch1.2 Pressure
- ch1.3 In Flow
- ch1.4 Out Flow
- ch1.5 Temp
- ch1.6 I/P A6
- All

---

The Alarm Event log is not group specific. To acknowledge a particular alarm, use the ▲, ▼ and ⏏ keys to first select the relevant process group, followed by the alarm to be acknowledged.

To acknowledge all active alarms in the selected process group simultaneously, select 'All' and press the ⏏ key.

**Note.** If an alarm in **the other** process group is active, the Global Alarm status icon (🔔) continues to be displayed in the status bar. If an active alarm in **the other** process group is unacknowledged, the icon is surrounded by a red flashing border (🔔).

If neither alarm on a particular channel is configured, the short channel tag is shown greyed-out in the menu.

2.8 Totalizer Log – Fig. 2.9

**Note.**

- The Totalizer log view is displayed only if the Totalizer option is enabled.
- The Totalizer log view provides an historical log of totalizer activity. To view the current totalizer status, choose the Process or Digital View.
- When the number of entries in the Totalizer log has reached that defined in 'Totalizer log size' (see Section 4.4.6, page 60), the oldest data is overwritten by the newest. Entries are renumbered so that the number of the oldest entry is always 00.
- The logging of totalizer values can be triggered at pre-determined intervals and/or by digital signal – see 'Log update' on page 85.

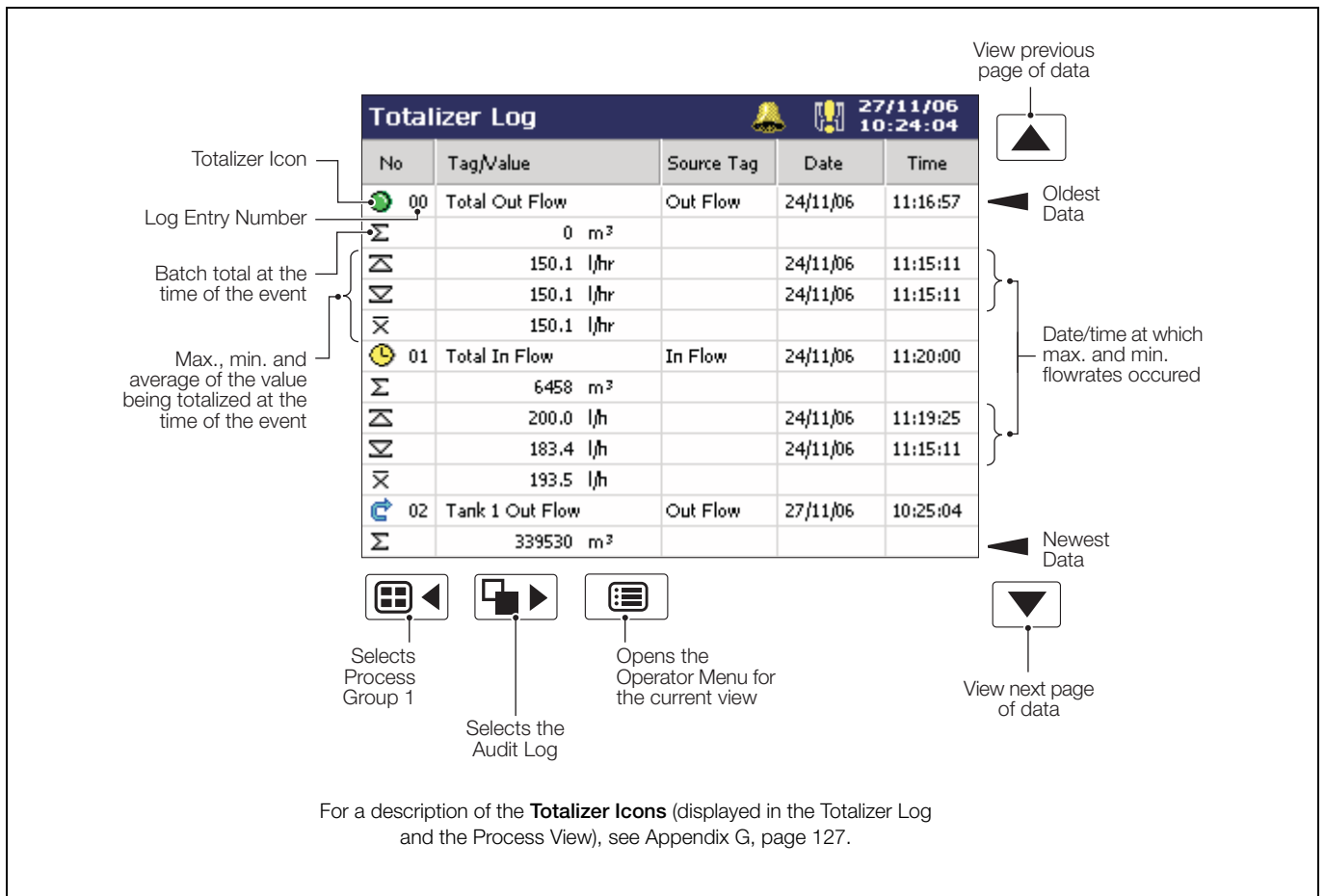

Fig. 2.9 Totalizer Log

**Note.** Maximum, Minimum and Average statistics are not shown unless enabled in the 'Filter' menu – see overleaf.



Configuration ▶

---

Select the Configuration Level – see Section 4, page 45.

Setup ▶

---

Select the Setup Level – see Section 3, page 29.

Filter ▶

- ✓ Group 1 Totalizers
- Group 2 Totalizers
- ✓ Statistics

---

Select the entries to be displayed in the log. ✓ Indicates entries currently displayed. This does not affect which events are recorded in the log.

'Statistics' displays the maximum, minimum and average values of the analog value being totalized, together with the dates and times at which all maximum and minimum values occurred.

These values are reset when the totalizer is reset and are updated only when the totalizer is running.

---



2.10 Status View – Fig. 2.11

**Note.** The Status view provides an overview of the instrument's status.

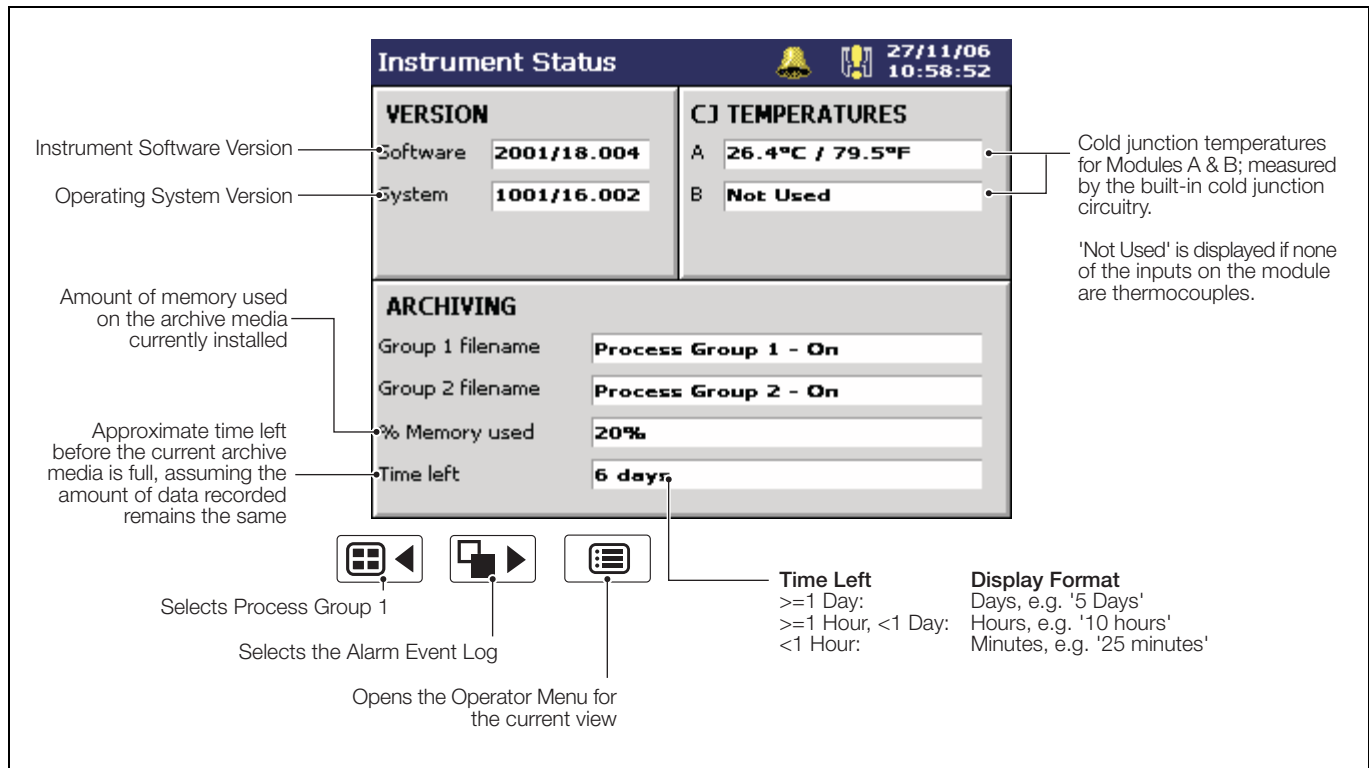

Fig. 2.11 Status View



Configuration ▶

Select the Configuration Level – see Section 4, page 45.

Setup ▶

Select the Setup Level – see Section 3, page 29.

## 3 Setup

### 3.1 Introduction

**Note.** Users with Setup access can:

- Start/Stop recording.
- Switch between primary and secondary recording rates.
- Set archiving 'on-line' and 'off-line'.
- View internal and external archive media file directories and delete external archive media files.

### 3.2 Accessing the Setup Level – Figs. 3.2 and 3.3

Access to the Setup Level is controlled by the instrument's Security System – see Section 4.4.7, page 60.

- If 'Security System' is set to 'Basic' and 'Setup Level Security' is set to 'Off', access to the Setup Level is unrestricted.
- If 'Security System' is set to 'Basic' and 'Setup Level Security' is set to 'On', access to the Setup Level is protected by a single password for all users. Refer to Fig. 3.2 to access the Setup Level.
- If 'Security System' is set to 'Advanced' and 'Setup Level Security' is set to 'On', access to the Setup Level is protected by a unique password for each authorized user. Refer to Fig. 3.3 to access the Setup Level.

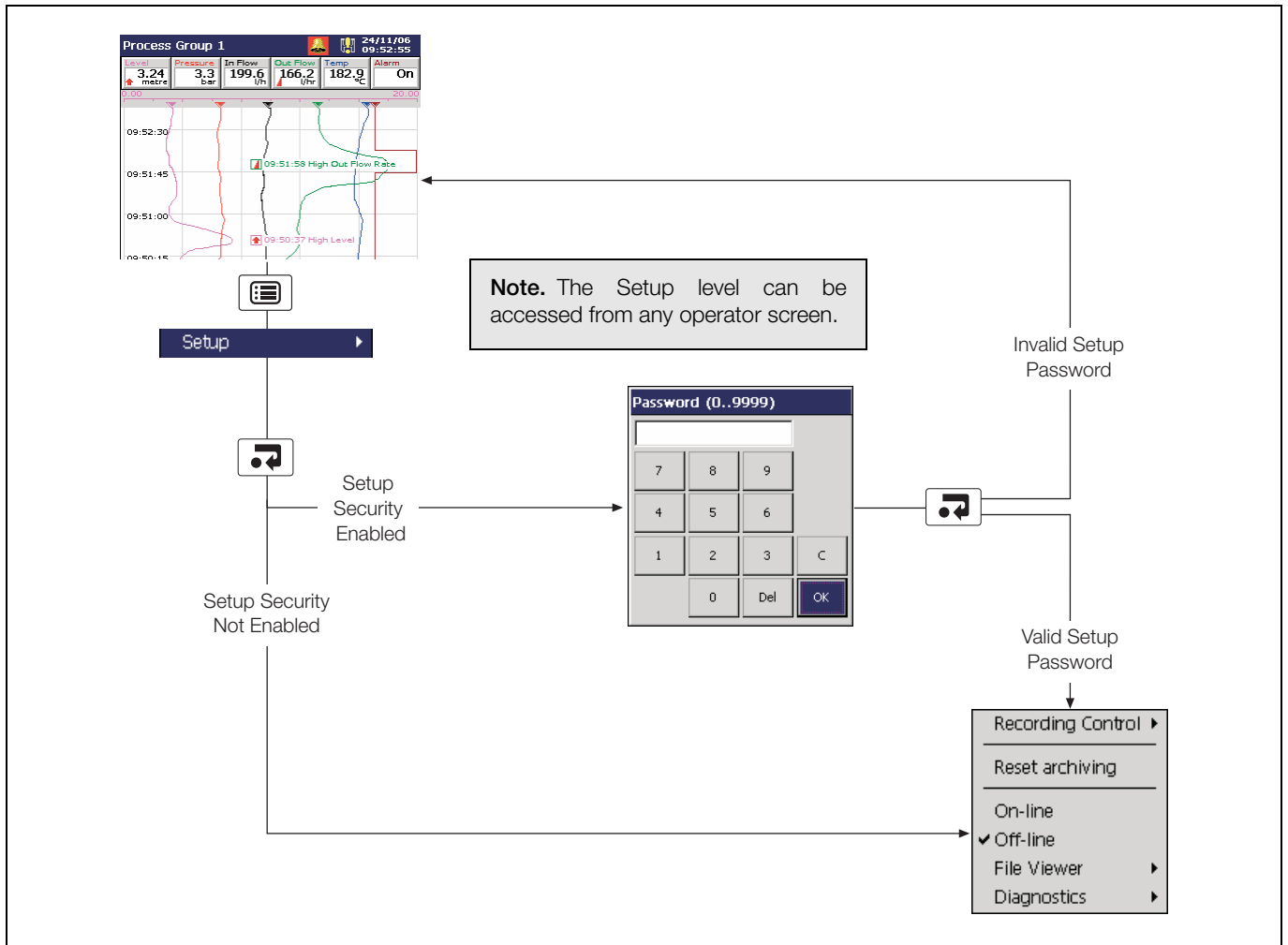

Fig. 3.1 Accessing the Setup Level – Basic Security

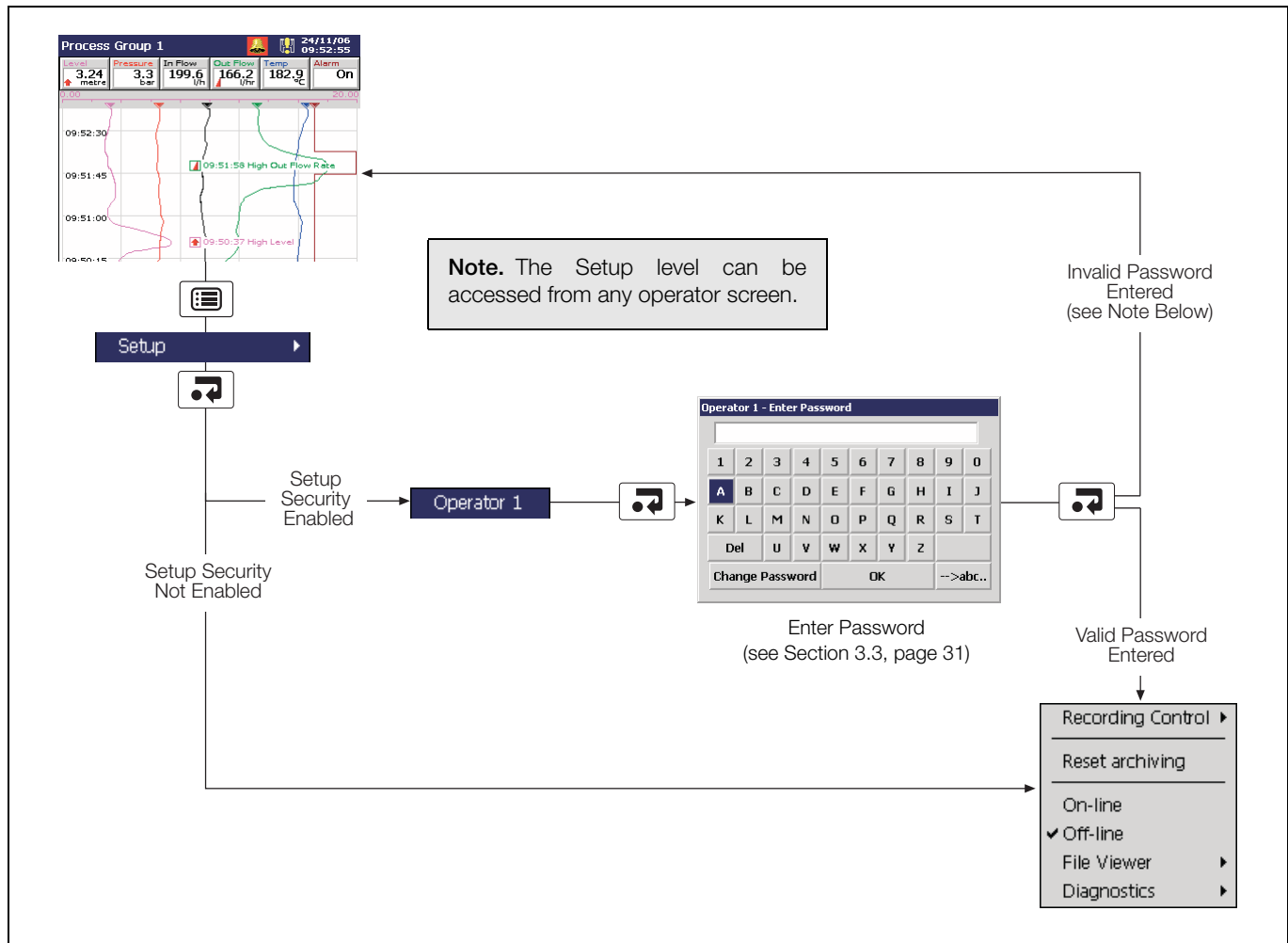

Fig. 3.2 Accessing the Setup Level – Advanced Security

**Note.** If an incorrect password is entered the display returns to the Operating view. However, if the maximum number of consecutive incorrect password entries is exceeded, the user's access privileges are removed and the following message is displayed:



If this occurs, access privileges can be reinstated only by the system administrator (User 1). If the system administrator's access privileges have been removed, the security system must be disabled using the configuration security switch (Yellow switch) to gain access to the configuration – see Section 4.1.2, page 45.

### 3.3 Password Entry

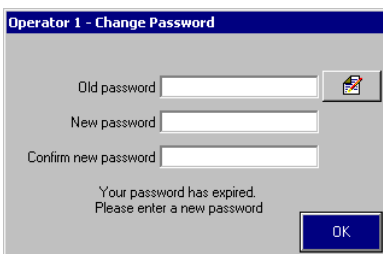
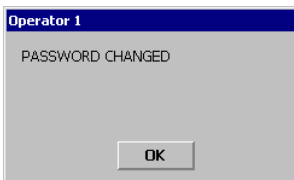
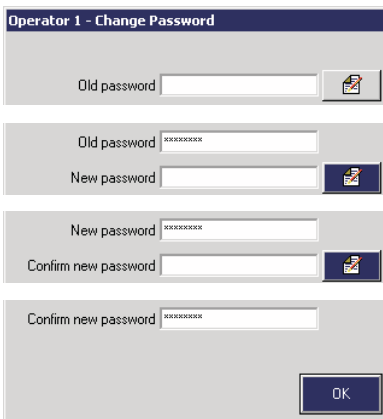

#### Enter Password

1. Select the required character using the , , and keys.
2. Add the selected character to the password string using the key.  
**Note.** For security, all characters are displayed as '\*':
3. Repeat 1 and 2 until all characters have been entered.
4. Highlight the 'OK' button using the , , and keys and press .

#### Change Password

Select 'Change Password' using the , , and keys and press .

1. Highlight the Edit Button () using the and keys and press to display the character entry box.
2. Enter the old password using the , , and keys. Highlight the 'OK' button and press .
3. Enter the new password using the same procedure as for the old password.
4. Enter the new password again to confirm it.
5. Highlight the 'OK' button and press .

Password change successful.

**Note.** If the key is pressed at any stage or 'OK' is selected before the new password is confirmed, the password change operation is cancelled and the following message is displayed:

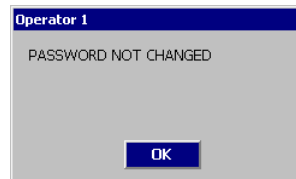

#### Password Expired

Passwords can be configured to expire at pre-determined intervals. If a password is time expired, this screen is displayed automatically. Enter a new password as described above.

### 3.4 Setup Menu

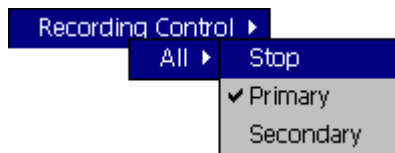

Use this menu to stop and start recording or switch between the Primary and Secondary sample rates for the current Process Group.

The Primary sample rate is set typically to a relatively slow rate (depending upon process recording requirements) and is active during normal process operating conditions in order to maximize internal memory and external archive media.

The Secondary sample rate is set typically to a faster rate than the Primary sample rate and may be selected manually in order to record the maximum amount of detail during, for example, an alarm condition.

The rates are set during configuration – see Section 4.5.1, page 61.

**Note.**

- Switching between the primary and secondary sample rates does not affect the screen interval in the Chart view.
- When the channels are set to 'Stop' the instantaneous values in the associated indicators are displayed in red and, after the end of the next sample period, no further samples are plotted on the associated traces.
- Digital recording channels can only be set to 'Stop' or 'Go'.
- Recording control can also be implemented using digital sources – see Sections 4.5.1 page 61 and 4.6.1 page 72.

### Reset archiving

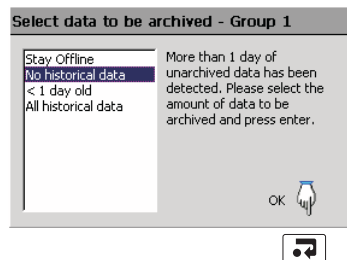

If selected, the date of the oldest unarchived data is set to that of the oldest data in the internal flash memory. This allows all data in the internal memory to be re-archived to external media.

**Note.** Ideally, a blank media storage card should be inserted prior to selecting this function.

To re-archive data:

1. Insert archive media, with sufficient free space, into the instrument.
2. Select 'Off-line' in the Setup Menu.
3. Select 'Reset archiving' in the Setup Menu.
4. Select 'On-line' in the Setup Menu.
5. Select data to be archived if >1 hour (Text format) or >1 day (Binary format) of data in internal memory and press .

On-line

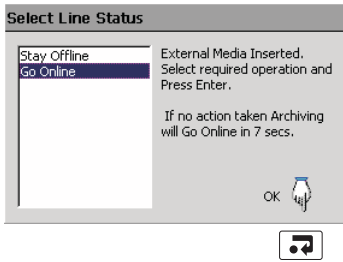

Places the archive media on-line, starting the archiving process.

**Note.**

- The On-line function is disabled (greyed-out in the Setup Menu) if no archive media card is inserted or the instrument has been placed in Historical Review mode.
- When an archive media card is inserted and there is <1 hour (Text format) or <1 day (Binary format), the 'Select Line Status' dialog box (left) is displayed, giving the user the choice of placing archiving on-line or remaining off-line. Archiving is placed automatically on-line in 10 seconds unless 'Stay Offline' is selected.
- When an archive media card is inserted and there is >1 hour (Text format) or >1 day (Binary format) of data in internal memory, the 'Select data to be archived' dialog box (previous page) is displayed. Select data to be archived and press .

Once selected, all data within the selected time frame is archived. Older unarchived data remains in the internal memory buffer until overwritten by newer data but is not available for archiving unless 'Reset archiving' is selected.

Off-line

Places the archive media off-line. Recording of channel data into internal memory continues uninterrupted but archiving to the removable media is suspended until it is put on-line again.

**Note.**

- Always set the external media Off-line before removing it.
- The Off-line function is disabled (greyed-out in the Setup Menu) when in Historical Review mode.

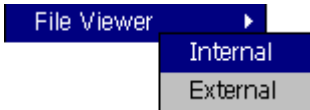

Use the file viewer to view a list of the files stored in internal memory and on external archive media.

**Note.** Files stored in internal memory cannot be deleted.

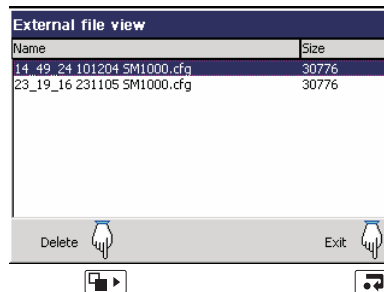

### 3.5 Archiving

Recorded data, logs and configuration files stored on the instrument's internal memory can be archived to files created on removable media. Parameters for archiving Process Groups 1 and 2 data are set up independently.

**Note.** To configure Archiving, refer to Section 4.5.6.

#### 3.5.1 Card Compatibility

Our recorders comply with approved industry standards for memory cards. SanDisk Standard Grade memory cards have been fully tested and are recommended for use with our recorders. Other brands may not be fully compatible with this device and therefore may not function correctly.

#### 3.5.2 Media Status – Fig. 3.3

**Process Group 1** 12/12/06 10:03:51

**Instrument Status** 27/11/06 10:58:52

<b>VERSION</b>		<b>C/J TEMPERATURES</b>	
Software	2001/18.004	A	26.4°C / 79.5°F
System	1001/16.002	B	Not Used

**ARCHIVING**

Group 1 filename: Process Group 1 - On  
 Group 2 filename: Process Group 2 - On  
 % Memory used: 20%  
 Time left: 6 days

- External archive media not inserted (yellow flashing exclamation mark)
- External archive media on-line (green icon, shaded area indicates % used)
- External archive media off-line (grey icon, shaded area indicates % used)
- External archive media update in progress (see Note below)
- External media 100% full, archiving stopped (green/red icon, flashing white cross)
- Warning! Too many files (green icon – media online, grey icon – media offline)
- Too many files, archiving stopped (red icon, flashing yellow cross)

Amount of memory used on the external archive media currently installed

Approximate time left before the current external archive media is full, assuming the amount of data recorded remains the same.

<b>Time Left</b>	<b>Display Format</b>
>=1 Day:	Days, e.g. '5 Days'
>=1 Hour, <1 Day:	Hours, e.g. '10 hours'
<1 Hour:	Minutes, e.g. '25 minutes'

Fig. 3.3 Media Status Icons

**Note.** Do not remove media while either of the media update in progress status icons (🔴➡️ or 🔴⬅️) are displayed.

### 3.5.3 Inserting and Removing Media – Fig. 3.4

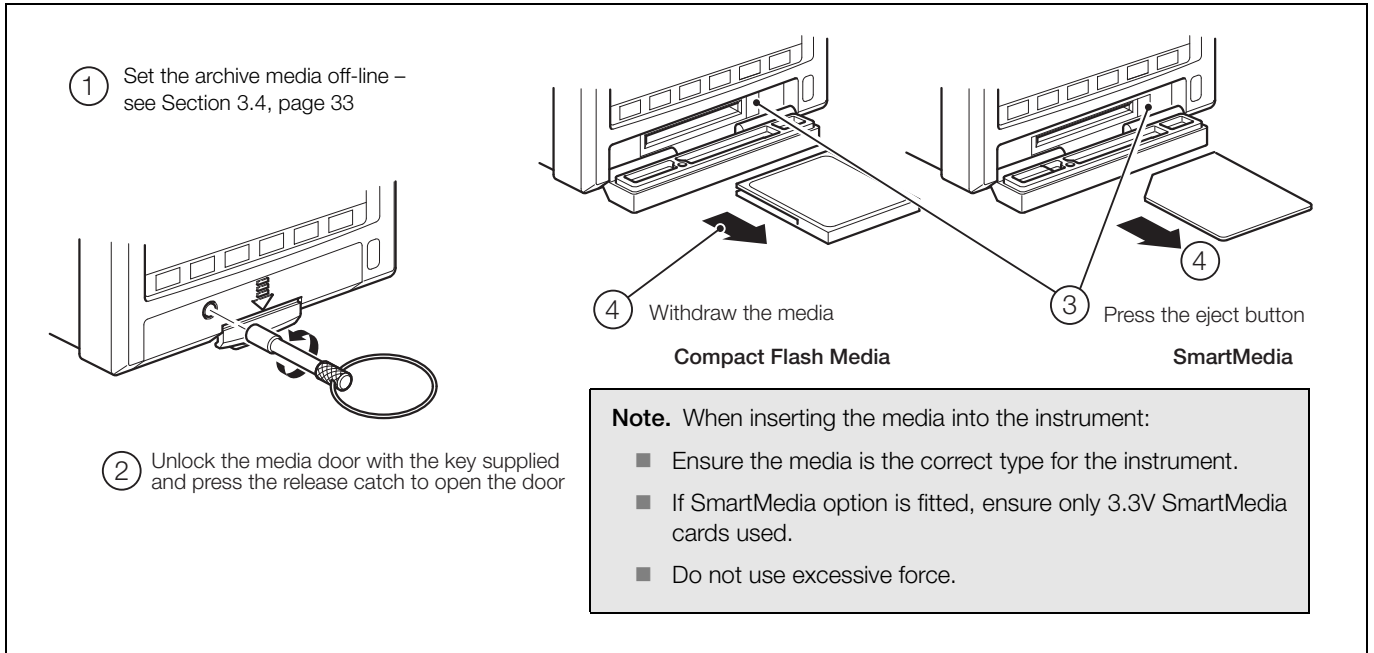

Fig. 3.4 Inserting and Removing External Media

### 3.5.4 Archive File Types

Archive files are created in one of two user-selectable formats:

Text (comma separated values [.csv]) – see Section 3.6, page 37

or

Secure binary encoded – see Section 3.7, page 41

All archive files created by the instrument are given filenames automatically but each type of archived file is given a different file extension depending on whether Text or Binary format has been selected during archive configuration – see Section 4.5.6, page 70. File types and extensions for Text files are shown in Table 3.1. File types and extensions for Binary files are shown in Table 3.2.

Type	Extension	Contents
Channel data files	*.D**	Analog or digital recording channels in the current process group.
Alarm event log files	*.E**	The historical record of the alarm events related to the group's channels plus the history of any operator messages, electronic signatures or real time alarms.
Totalizer log files	*.T**	The historical record of all totalizer and associated statistical values relating to the group's recording channels.
Audit log files	*.A**	The historical entries from the audit log. (Note. The content of this file is the same for all groups).
Digital signature files	*.S**	Digital signature file for the corresponding channel data file.
Batch data files	*.V**	Analog or digital recording channels in the current process group when the batch function is active.
Batch log files	*.X**	Historical record of the batches recorded.

Table 3.1 Text Format File Types and Extensions

Type	Extension	No. of Files	Contents
Channel data files	*.B00	One per channel	Analog or digital recording channel data
Batch channel data files	*.V**	One per channel	Batch recording channel data *.
Alarm event log files	*.EEO	One per process group	The historical record of the alarm events related to a particular process group's channels plus the history of any operator messages, electronic signatures or real time alarms.
Totalizer log files	*.TEO	One per process group	The historical record of all totalizer and associated statistical values relating to a particular group's recording channels.
Audit log files	*.AEO	One per instrument	The historical entries from the audit log.
Batch log files	*.X**	One per process group	Batch information associated with a process group *.

\* Batch files are created only if the Batch Recording software option is enabled.

Table 3.2 Binary Encoded Format File Types and Extensions

### 3.6 Text Format Archive Files

#### 3.6.1 Text Format Channel Data Files

Text format channel data files can be configured to contain data gathered over a predefined period of time using the 'New File Interval' setting – see Table 3.3.

New File Interval	Filename
Hourly	<hour> <day, month, year>* <filename tag>
Daily	<day, month, year>* <filename tag>
Monthly	<month, year>* <filename tag>
None	<filename tag>

\* Formatted according to the date format set in Common Configuration – see Section 4.4.3, page 54

Table 3.3 New Text File Intervals

**Note.** The 'New File Interval' is set in the Configuration level – see Section 4.5.6, page 70.

In addition to new channel data files being created according to the New File Interval selection, they are also created in the following circumstances if automatic update is enabled and the media is on-line or if a manually triggered update is in progress:

- The instrument's power is lost then restored.
- The instrument is taken offline and the archive media removed, replaced or refitted.
- The instrument's configuration is changed.
- One of the current files exceeds the maximum permissible size.
- When the daylight saving period starts or ends.

**Note.** The instrument's internal clock can be configured to adjust automatically at the start and end of Daylight Saving Time (Summertime) periods – see Section 4.4.6, page 60.

When one of these conditions occurs, new channel data files are created for each enabled group and the file extension index on each new file is incremented by one from the previous file.

**Example** – if the original file had an extension of .D00, after one of the above events a new file will be created with the same filename but an extension of .D01.

Files containing data generated during the daylight saving period (summertime) have '~DS' appended to the filename.

**Example 1** – Start of daylight saving period:

A daily file is started at 00:00:00 on 30th March 2003 – filename: 30Mar03ProcessGroup1.D00.

Summertime starts at 2:00am on 30th March 2003.

The clock changes automatically to 3:00am.

The existing file is closed and a new file is created –filename: 30Mar03ProcessGroup1~DS.D00.

The file '30Mar03ProcessGroup1.D00' contains data generated from 00:00:00 to 01:59:59 (before summertime starts).

The file '30Mar03ProcessGroup1~DS.D00' contains data generated from 03:00:00 (after summertime starts).

**Example 2** – End of daylight saving period:

A daily file is started at 00:00:00 on 26th October 2003 – filename: 26Oct03ProcessGroup1~DS.D00

Summertime ends at 3:00am on 26th October 2003.

The clock changes automatically to 2:00am.

The existing file is closed and a new file is created –filename: 26Oct03ProcessGroup1.D00

The file '26Oct03ProcessGroup1~DS.D00' contains data generated from 00:00:00 to 02:59:59 (before summertime ends).

The file '26Oct03ProcessGroup1.D00' contains data generated from 02:00:00 (after summertime ends)

### 3.6.2 Text Format Filename Examples

'New file interval' set to 'Hourly', 'Filename tag' set to 'Process Group 1' (see Section 4.5.6, page 70); date is 10th October 2000; Channel data and alarm event log files only enabled:

9:00 am New file created in which all channel data recorded between 9:00 and 9:59:59 is archived in the following file:  
09\_00\_10Oct00\_Process\_Group\_1.d00

09:12am Power interrupt occurs

09:13am Power restored and new file created:  
09\_00\_10Oct00\_Process\_Group\_1.d01

10:00am New file created in which all data recorded between 10:00 and 10:59:59 is archived.  
10\_00\_10Oct00\_Process\_Group\_1.d00

**Note.**

- Hourly files start exactly on the hour.
- Daily files start at 00:00:00.
- Monthly files start at 00:00:00 on the first of the month.

### 3.6.3 Text Format Log files

The Alarm Event and Totalizer Logs for each Process Group and the Audit Log are archived into individual files. The filenames are formatted as shown in Table 3.4 with the date and the time indicating the first entry in the file.

Log File	Filename
Alarm Event	<hour min> <dd, mm, yy>* <process group tag>.e00
Totalizer	<hour min> <dd, mm, yy>* <process group tag>.t00
Audit	<hour min> <dd, mm, yy>* <instrument tag>.a00

\* Formatted according to the date format set in Common Configuration – see Section 4.4.3, page 54

Table 3.4 Log File Formats

If one of the archive log files becomes full (>64000 entries) a new file is created with an extension incremented by 1, e.g. a01, e01 etc.

**Note.** Totalizer logs are created only if the totalizer option is enabled.

New text format log data files are also created when the daylight saving period starts or ends.

Files containing log data generated during the daylight saving period (summertime) have '-DS' appended to the filename.

### 3.6.4 Text Format Data File Examples – Figs. 3.5 to 3.8

Text format archived data is stored in a comma separated value (\*.csv) format so that it can be imported directly into a standard spreadsheet, e.g. Microsoft Excel™ and Lotus 1-2-3™. The files can also be read as an ASCII text file by a text viewer. When imported into a spreadsheet, the files appear as shown in Figs. 3.5 to 3.8.

Alternatively, detailed graphical analysis of the data can be carried out on a PC using the Company's DataManager data analysis software package.

### 3.6.5 Text Format Data File Digital Signatures – Fig. 3.5

A digital signature file is created for each channel data file using the same filename but with a \*.S\*\* extension. The file contains a unique 'fingerprint' of the contents of the data file that can be used to prove if the data has been tampered with or corrupted. Data validation can be carried out on a PC using the Company's DataManager software package.

### 3.6.6 Text Format Data Verification and Integrity

When data is saved to the archive media it is checked automatically to verify that the date value stored on the media matches exactly the date value stored in the internal memory.

	A	B	C	D	E	F	G	H	I	J	K
1											
2	Configuration file		10_30_25	12 Apr 00	Instrument #3						
3	Group tag		Plant A - Zone 1								
4											
5	CH1.1	Boiler 1 temperature	No. dp's =	0	Eng lo = -50		Eng hi = 1300	°C			
6	CH1.2	Inlet flow rate	No. dp's =	1	Eng lo = 0		Eng hi = 999.9	Ltr/h			
7	CH1.3	OFF									
8	CH1.4	Ambient min temp	No. dp's =	2	Eng lo = 10		Eng hi = 120	°F			
9	CH1.5	Tank 1 level	No. dp's =	1	Eng lo = 0		Eng hi = 200	Litres			
10	CH1.6	Digital				0 = Close		1 = Open			
11											
12	Date	Time	Boiler 1	Flow 1	Amb max	Amb min	Tank 1	Tank 1	Inlet		
13			CH1.1	CH1.2	CH1.3	CH1.4	CH1.5	CH1.5	CH1.6		
14			°C	Ltr/h		°F	Litres	Litres	0=Close		
15			instant	ave	OFF	min	max	min	1 = Open		
16	12-Apr-00	11:00:00.0	500	800.1		58.9	75.8	75.8	0		
17	12-Apr-00	11:00:00.1	501	800.2		58.71	76.3	76	0		
18	12-Apr-00	11:00:00.2	502	800.3		58.81	76.8	76.5	0		
19	12-Apr-00	11:00:00.3	503	800.4		58.91	77.3	77	0		
20	12-Apr-00	11:00:00.4	505	800.5		59.01	77.8	77.5	0		
21	12-Apr-00	11:00:00.5	504	800.6		59.11	78.3	78	0		

Fig. 3.5 Channel Data File Sample – Text Format

	A	B	C	D	E	F	G	H
1	Group tag		Plant A - Zone 1					
2								
3	Date	Time	Type	Event tag	Source tag	Trip value	Units	State
4	12-Apr-00	08:00:00	Hi Process	Boiler 1 too high	Boiler 1	750	C	Active
5	12-Apr-00	08:10:00	Lo Process	Flow 2 below limit	Flow 2	5.2	Ltr/h	Active
6	12-Apr-00	08:20:00	Hi Process	Boiler 1 too high	Boiler 1	750	C	Active
7	12-Apr-00	08:30:00	Lo Process	Flow 2 below limit	Flow 2	5.2	Ltr/h	Active
8	12-Apr-00	08:40:00	Hi Process	Boiler 1 too high	Boiler 1	750	C	Inactive
9	12-Apr-00	08:50:00	Lo Process	Flow 2 below limit	Flow 2	5.2	Ltr/h	Inactive
10	12-Apr-00	09:00:00	Op Message	Batch 1 started				
11	12-Apr-00	09:10:00	Hi Process	Reduce flow	Zone 3	275.3	m	Active
12	12-Apr-00	09:20:00	Lo Process	Open Inlet Valve	Flow 5	500	Gal/h	Active
13	12-Apr-00	09:30:00	Lo Process	Open Inlet Valve	Flow 5	500	Gal/h	Active

Fig. 3.6 Alarm Event Log Sample – Text Format

	B	C	D	E	F	G	H	I	J	K
1		Plant A - Zone 1								
2										
3	Boiler 1 temperature		No. dp's = 0		Eng lo = -50		Eng hi = 1300		C	
4	Inlet flow rate		No. dp's = 1		Eng lo = 0		Eng hi = 999.9		Ltr/h	
5	Ambient max temp		No. dp's = 2		Eng lo = 10		Eng hi = 120		F	
6	Ambient min temp		No. dp's = 2		Eng lo = 10		Eng hi = 120		F	
7	Tank 1 level		No. dp's = 1		Eng lo = 0		Eng hi = 200		Litres	
8	Digital				0 = Close		1 = Open			
9										
10										
11	Time	Totalizer Tag	Source tag	Batch total	Total units	Max value	Min value	Average	Units	Secure Total
12										
13	08:00:00	FT_Zone 1_123.1	Flow 1	1232134578	Litres	800.1	800.1	800.1	Ltr/h	8932103235
14	08:10:00	FT_Zone 1_123.1	Flow 1	1232134628	Litres	810.4	805.2	807.8	Ltr/h	8932103285
15	08:20:00	FT_Zone 1_123.1	Flow 1	1232134678	Litres	820.7	815.5	818.1	Ltr/h	8932103335
16	08:30:00	FT_Zone 1_123.1	Flow 1	1232134728	Litres	831	825.8	828.4	Ltr/h	8932103385
17	08:40:00	FT_Zone 1_123.1	Flow 1	1232134778	Litres	841.3	836.1	838.7	Ltr/h	8932103435
18	08:50:00	FT_Zone 1_123.1	Flow 1	1232134828	Litres	851.6	846.4	849	Ltr/h	8932103485
19	09:00:00	FT_Zone 1_123.1	Flow 1	1232134878	Litres	861.9	856.7	859.3	Ltr/h	8932103535
20	09:10:00	FT_Zone 1_123.1	Flow 1	1232134928	Litres	872.2	867	869.6	Ltr/h	8932103585

Fig. 3.7 Totalizer Log Sample – Text Format

	A	B	C	D	E
1	Date	Time	Type of event	Description	Op id
2					
3	12-Apr-00	08:00:00	Power failure		User 4
4	12-Apr-00	08:10:00	Power recovery		User 4
5	12-Apr-00	08:30:00	Analog i/p Calibration	Module A	User 1
6	12-Apr-00	08:40:00	Analog i/p Calibration	Module B	User 1
7	12-Apr-00	08:50:00	File Created	Configuration	User 1
8	12-Apr-00	09:00:00	File Created	Group 1 data	User 1
9	12-Apr-00	09:10:00	File Created	Group 1 alarm event log	User 1
10	12-Apr-00	09:40:00	Configuration change		User 3
11	12-Apr-00	09:50:00	Media removed		User 3

Fig. 3.8 Audit Log Sample – Text Format

### 3.7 Binary Format Archive Files

#### 3.7.1 Binary Format Archive Filenames

Examples of binary archive filenames are shown in Table 3.5.

Type	Format
Channel data files	<Start Time HHMMSS><Start Date DDMMYY><Ch<Group>_<Channel><Instrument tag> e.g. 14322719Dec03Ch1_2Boiler room3
Alarm event log files	<Start Time HH_MM><Start Date DDMMYY><Process Group Tag> e.g. 14_3219Dec03Boiler5
Totalizer log files	<Start Time HH_MM><Start Date DDMMYY><Process Group Tag> e.g. 14_3219Dec03Boiler5
Audit log files	<Start Time HH_MM><Start Date DDMMYY><Instrument Tag> e.g. 14_3219Dec03Boiler room 3

Table 3.5 Binary Archive Filenames

#### 3.7.2 Binary Format Channel Data Files

A new binary format channel data file is created under the following conditions:

- When the current file for a channel does not exist on the media card.
- When the maximum size (5Mb) of the existing data file is exceeded.
- When the recording channel's configuration is changed.
- When the daylight saving period starts or ends.

**Note.** The instrument's internal clock can be configured to adjust automatically at the start and end of Daylight Saving Time (Summertime) periods – see Section 4.4.6, page 60.

Files containing channel data generated during the daylight saving period (summertime) have '~DS' appended to the filename.

##### Example 1 – Start of daylight saving period:

Archiving is started at 01:45:00 on 30th March 2003 – filename: 01450030Mar03Ch1\_1AnlgSM2000.B00.

Summertime starts at 2:00am on 30th March 2003.

The clock changes automatically to 3:00am.

The existing file is closed and a new file is created –filename: 03000030Mar03Ch1\_1AnlgSM2000~DS.B00.

The file '01450330Mar03Ch1\_1AnlgSM2000.B00' contains data generated from 01:45:00 to 01:59:59 (before summertime starts).

The file '03000030Mar03Ch1\_1AnlgSM2000~DS.B00' contains data generated from 03:00:00 (after summertime starts).

##### Example 2 – End of daylight saving period:

Archiving is started at 00:15:00 on 26th October 2003 – filename: 00150026Oct03Ch1\_1AnlgSM2000~DS.B00.

Summertime ends at 3:00am on 26th October 2003.

The clock changes automatically to 2:00am.

The existing file is closed and a new file is created –filename: 02000026Oct03Ch1\_1AnlgSM2000.B00.

The file '00150026Oct03Ch1\_1AnlgSM2000~DS.D00' contains data generated from 00:15:00 to 02:59:59 (before summertime ends).

The file '02000026Oct03Ch1\_1AnlgSM2000' contains data generated from 02:00:00 (after summertime ends).

#### 3.7.3 Binary Format Log files

A new binary log file is created under the following conditions:

- When an existing valid binary log file does not exist on the media card.
- When the maximum size (64000 entries) is exceeded.
- When the daylight saving period starts or ends.

Files containing log data generated during the daylight saving period (summertime) have "~DS" appended to the filename.

#### 3.7.4 Binary Format Data File Examples – Figs. 3.9 to 3.12

Binary format archived data is stored in a secure binary encoded format. A separate file is created for each recording channel. The log data is stored in an encrypted text format. The files can be read on a PC using the Company's DataManager data analysis software package.

**Note.** Binary format archive files created during the daylight saving period (summertime) are compatible with the database feature of Version 5.8 (or later) only of the Company's DataManager data analysis software package.

#### 3.7.5 Binary Format Data Verification and Integrity

When data is saved to the archive media it is checked automatically to verify that the data stored on the media matches exactly what is stored in the internal memory.

Each block of data in the channel data files has its own data integrity check. This enables the integrity of the data stored on the external media card to be verified when it is viewed using the Company's DataManager software package.

The log files also contain built-in integrity checks enabling the integrity of the data to be verified by the DataManager software.

Instrument:		SM2000(A/45678/4/4)					
Group tag		Boiler Room 1					
CH1.1	Boiler Pressure	0.0..100.0 bar					
CH1.2	Inlet Flow Rate	0.0..100.0 Gal/h					
CH1.3	Tank Level	0.0..5000 Gal					
CH1.4	Outlet Flow Rate	0.0..100.0 Gal/h					
CH1.5	Boiler Temperature	0.0..1000 C					
CH1.6	Valve Status	Close..Open					
<b>SM2000(A/45678/4/4) Process Group 2</b>							<b>Data Integrity Verified Successfully</b>
Date	Time	Press	InFlow	Level	OutFlow	Temp	Valve
		CH1.1	CH1.2	CH1.3	CH1.4	CH1.5	CH1.6
		bar	Gal/h	Gal	Gal/h	C	0= Close
		instant	instant	instant	instant	instant	1= Open
28/May/03	00:54:15	64.2	80.1	51.5	33.1	69.3	0
28/May/03	00:54:16	64.3	80.2	51.6	33.2	69.9	0
28/May/03	00:54:17	64.4	80.2	51.7	33.3	70.4	0
28/May/03	00:54:18	64.5	80.3	51.8	33.4	71.0	0
28/May/03	00:54:19	64.6	80.3	51.9	33.5	71.6	0
28/May/03	00:54:20	64.7	80.4	52.0	33.6	72.1	0
28/May/03	00:54:21	64.8	80.4	52.1	33.7	72.7	0
28/May/03	00:54:22	64.8	80.5	52.2	33.8	73.2	0
28/May/03	00:54:23	64.9	80.5	52.3	33.9	73.8	0
28/May/03	00:54:24	65.0	80.6	52.4	34.0	74.3	0
28/May/03	00:54:25	65.1	80.6	52.5	34.1	74.9	1
28/May/03	00:54:26	65.2	80.7	52.6	34.2	75.4	1
28/May/03	00:54:27	65.3	80.7	52.7	34.4	76.0	1
28/May/03	00:54:28	65.3	80.8	52.8	34.5	76.6	1
28/May/03	00:54:29	65.4	80.9	52.9	34.6	77.1	1
28/May/03	00:54:30	65.5	80.9	53.0	34.7	77.7	1
28/May/03	00:54:31	65.6	81.0	53.1	34.8	78.2	1
28/May/03	00:54:32	65.7	81.0	53.2	34.9	78.8	1
28/May/03	00:54:33	65.8	81.1	53.4	35.0	79.3	0
28/May/03	00:54:34	65.8	81.1	53.5	35.1	79.9	0
28/May/03	00:54:35	65.9	81.2	53.6	35.2	80.4	0
28/May/03	00:54:36	66.0	81.2	53.7	35.4	81.0	0

Fig. 3.9 Channel Data File Sample – Binary Format

SM2000(A/45678/4/4) Process Group 1								
Date	Time	Type	Event tag	Source tag	Trip Value	Units	State	Ack
27/May/03	14:25:50	High process	Pressure 1 too high	Boiler 1	80	Bar	Active	Yes
27/May/03	14:26:50	Low process	Flow 1 below limit	Flow 1	5.2	Gal/h	Active	No
27/May/03	14:28:22	High process	Flow 2 above limit	Flow 2	12.2	Gal/h	Inactive	No
27/May/03	14:30:22	High process	Flow 2 above limit	Flow 2	12.2	%	Active	No
27/May/03	14:45:00	Real Time Alarm	Start Boiler 2				Active	No
27/May/03	14:48:52	High Rate	In Flow 1 too high	In Fow 1	5	Gal/h	Active	No
27/May/03	14:51:26	Op Message	Batch 1 Started					
27/May/03	14:51:26	High process	1.1A	I/P A1	50	%	Active	No
27/May/03	15:11:55	High process	1.1A	I/P A1	50	%	Inactive	No
27/May/03	14:45:00	Real Time Alarm	Start Boiler 1				Active	No

Fig. 3.10 Alarm Event Log Sample – Binary Format

SM2000(A/45678/4/4) Process Group 1											
Date	Time	Totalizer Tag	Source tag	Batch Total	Total units	Max value	Min value	Average	Units	Secure Total	Events
27/May/03	14:30:00	Total Flow 1.1	Flow 1	320000	Gal	99.9	39.9	72.3	Gal/h	320800	Started
27/May/03	14:30:00	Total Tank 1.1	Tank 1	320000	Gal	99.9	39.9	72.4	Gal/h	321538	Started
27/May/03	15:00:00	Total Flow 1.1	Flow 1	322112	Gal	99.9	39.9	72.3	Gal/h	322112	Timed
27/May/03	15:15:00	Total Tank 1.1	Tank 1	322758	Gal	99.9	39.9	72.3	Gal/h	322758	Timed
27/May/03	15:30:00	Total Flow 1.1	Flow 1	323484	Gal	99.9	39.9	72.4	Gal/h	323484	Timed
27/May/03	15:45:00	Total Tank 1.1	Tank 1	324046	Gal	99.9	39.9	72.3	Gal/h	324046	Timed
27/May/03	16:00:00	Total Flow 1.1	Flow 1	324720	Gal	99.9	39.9	72.4	Gal/h	324720	Timed
27/May/03	16:15:00	Total Tank 1.1	Tank 1	325426	Gal	99.9	39.9	72.4	Gal/h	325426	Timed
27/May/03	16:30:00	Total Flow 1.1	Flow 1	325983	Gal	99.9	39.9	72.3	Gal/h	325983	Timed
27/May/03	16:45:00	Total Tank 1.1	Tank 1	326686	Gal	99.9	39.9	72.4	Gal/h	326686	Timed
27/May/03	17:00:00	Total Flow 1.1	Flow 1	327366	Gal	99.9	39.9	72.4	Gal/h	327366	Timed
27/May/03	17:15:00	Total Tank 1.1	Tank 1	327926	Gal	99.9	39.9	72.3	Gal/h	327926	Timed
27/May/03	17:30:00	Total Flow 1.1	Flow 1	328649	Gal	99.9	39.9	72.4	Gal/h	328649	Reset
27/May/03	17:30:00	Total Tank 1.1	Tank 1	328302	Gal	99.9	39.9	72.4	Gal/h	329302	Reset

Fig. 3.11 Totalizer Log Sample – Binary Format

SM2000(A/45678/4/4)				
Date	Time	Type of event	Description	Op id
27/May/03	14:34:43	Power Failure		
27/May/03	14:50:09	Power Recovery		
27/May/03	14:54:39	Analog I/p Calibration	Module A	Joe Smith
27/May/03	14:57:11	Configuration change		Joe Smith
27/May/03	14:59:19	Online	Archiving data in group:1;2	
27/May/03	15:45:59	Offline		
27/May/03	15:46:02	Media removed		
28/May/03	08:16:43	Media inserted		
28/May/03	08:16:45	Online	Archiving data in group:1;2	

Fig. 3.12 Audit Log Sample – Binary Format

### 3.8 Archiving Online/Offline

Before data can be archived to external media, the external media must be placed on-line and one or more archive file enables set.

- When an external archive media card is inserted and there is <1 day (Binary format) or <1 hour (Text format) of data in internal memory, a dialog box is displayed giving the user the choice of putting the media on-line or remaining off-line. If no selection is made within 10 seconds, the media card is placed on-line automatically:

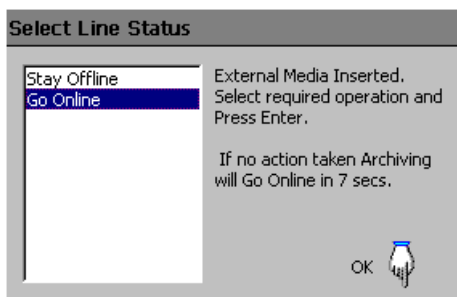

- When an external archive media card is inserted and there is >1 day (Binary format) or >1 hour (Text format) of data in internal memory, a dialog box is displayed prompting the user to select either the data to be archived or remain off-line:

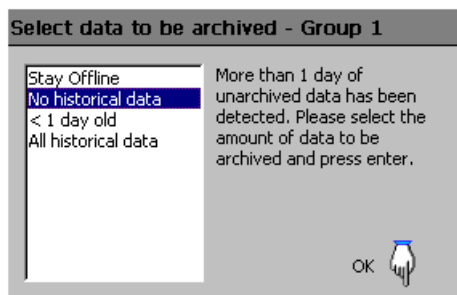

- If a large amount of Text format unarchived data is selected, a progress bar appears. During this time operator views cannot be accessed, but new data continues to be recorded to the internal buffer memory.

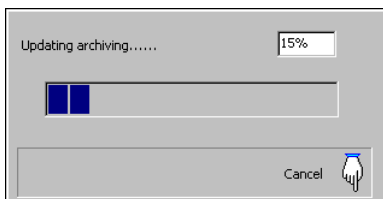

- External archive media can be set on-line (if a media card is inserted) or off-line in the setup menu.
- Set archiving off-line before removing external media to prevent loss of data and possible damage to the media card.
- When external archive media contains approximately 250 files, its read/write performance begins to degrade and either of the 'Warning – Too Many Files' icons (⚠ or ⚠) are displayed. Change the media as soon as possible.
- When external archive media contains approximately 300 files, its read/write performance becomes too slow, Archiving is stopped automatically and the 'Too Many Files – Archiving Stopped' icons (⛔ alternating with ⛔) are displayed. Change the media immediately to prevent loss of data.

**Note.** Data stored in the internal memory buffer can still be transferred to the archive media when the archive media is placed on-line again (providing it is not off-line so long that the un-archived data in the internal memory is overwritten).

### 3.9 Backing-up Archived Data

It is advisable to back-up critical data stored on SmartMedia or Compact Flash cards on a regular basis. The instrument's internal memory provides a buffer for the most recent data so, if data stored on archive media is lost, it can be re-archived – see 'Reset archiving' on page 32.

To ensure that all required data is available for re-archiving, it is recommended that data archived on archive media is removed and backed-up before the instrument's internal buffer overwrites that data. The length of time for which data remains in the instrument's internal memory depends on the sample rate and the number of channels selected – see Table C.1 on page 116 for details.

### 3.10 Archive Wrap

Archiving can be configured to delete the oldest archived data file automatically from the external media when the media approaches its maximum capacity – see 'Wrap' on page 71.

## 4 Configuration

### 4.1 Introduction

This section details the configuration of the instrument locally using the front panel membrane keys. A configuration file can also be created on a PC and transferred to the instrument via one of the archive media options.

In addition, up to 16 different configurations can be stored in internal memory and restored when required.

#### 4.1.1 Configuration Level Security

Two methods of configuration access protection are available:

1. **Password protection** (Factory Default).  
The Configuration level cannot be accessed until the correct password has been entered – see Fig. 4.1, page 46.
2. **Internal switch protection.**  
The Configuration level cannot be accessed until the instrument is withdrawn from its case and the internal switch set to the 'Configuration Level Not Protected' position – see Fig. 4.2, page 47.

Internal Security Switch Setting (see Fig. 4.2, page 47)	'Configuration security' Parameter Setting (see Section 4.4.4, page 56)	
	'Password protected' (Factory Default)	'Internal switch protected' (Alternative)
Configuration Level Protected (Factory Default)	Password Access	No Access
Configuration Level Not Protected	Free Access	Free Access

The instrument can be configured for one of two levels of password protection:

#### Basic Security:

- Up to 4 users
- Each user is assigned a unique 4-digit security code for Configuration level access
- Optional security code protection of access to Setup level

#### Advanced Security:

- Up to 12 users
- Each user is assigned a unique password of up to 20 characters
- Each user is assigned configuration, setup and/or electronic signature access privileges
- Each user is assigned one of 3 levels of configuration level access privileges
- Configurable password expiry times, password failure limits and minimum password length
- Inactive user disabling

**Note.** The electronic signature feature is available only with Advanced security.

#### 4.1.2 Configuration Level Access – Figs. 4.1 and 4.2

To configure an instrument when 'Configuration security type' is set to the factory default setting of 'Password protected':

- Access the Configuration Level – see Fig. 4.1, page 46.
- Make changes to parameters as detailed in Figs. 4.1 and 4.3.

To configure an instrument when 'Configuration security type' is set to 'Internal switch protected':

- Set the internal security switch to the 'Configuration Level Not Protected' position – see Fig. 4.2, page 47.
- Access the Configuration Level – see Fig. 4.1, page 46.
- Make changes to parameters as detailed in Figs. 4.1 and 4.3.

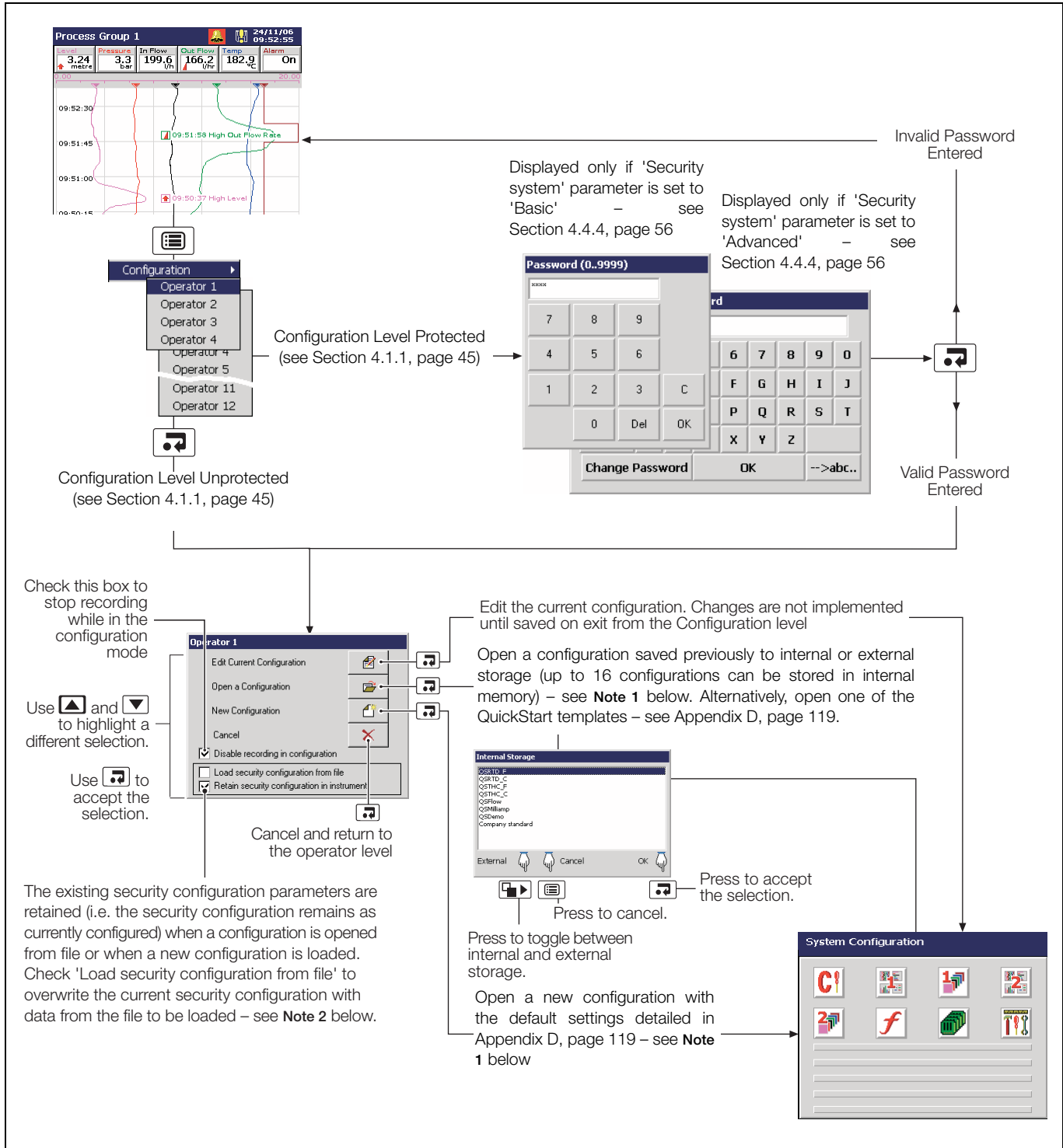

Fig. 4.1 Accessing the Configuration Level

**Note.**

1. If 'New Configuration' or 'Open a Configuration' is selected and the modified configuration file is saved later as the current configuration, new internal data files for all enabled recording channels are created and any unarchived data is lost.
2. The option to load or retain the security configuration applies only to Advanced Security mode and is available only to the System Administrator (User 1). If a new or existing configuration file is opened by a user other than the System Administrator, the instrument's existing security settings are retained.

**Note.** The Internal Security Switch is used to access the Configuration level when 'Configuration security' is set to 'Internal switch protected' – see Section 4.4.4, page 56. **Do Not** use the switch to access the Configuration level when 'Configuration security' is set to 'Password protected' (default setting) unless the Password has been forgotten. The switch overrides Password protection, enabling free access to the Configuration level.

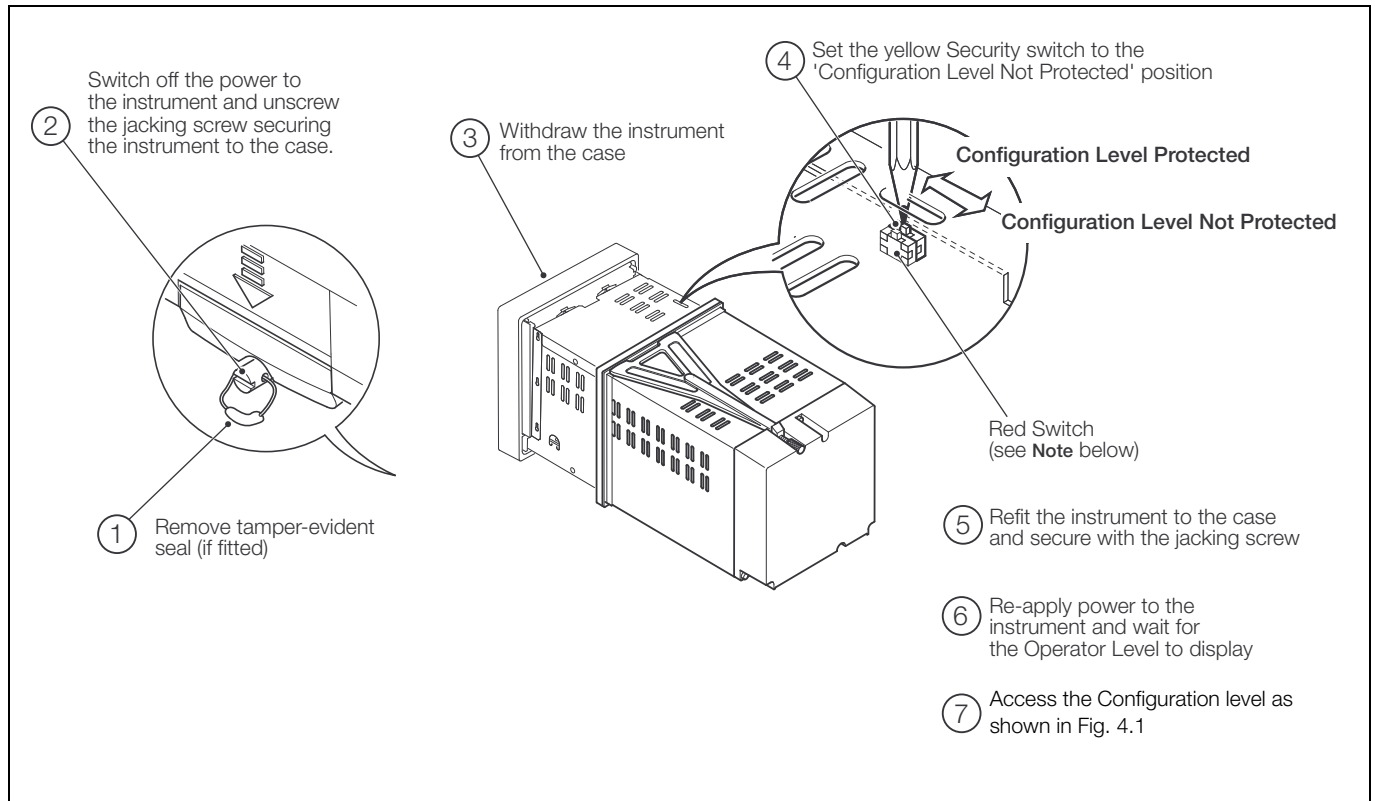

Fig. 4.2 Setting the Security Switch

**Note.** The red switch is for factory use only. Ensure it remains in the position closest to the rear of the instrument.

4.2 Overview of Configuration – Fig. 4.3

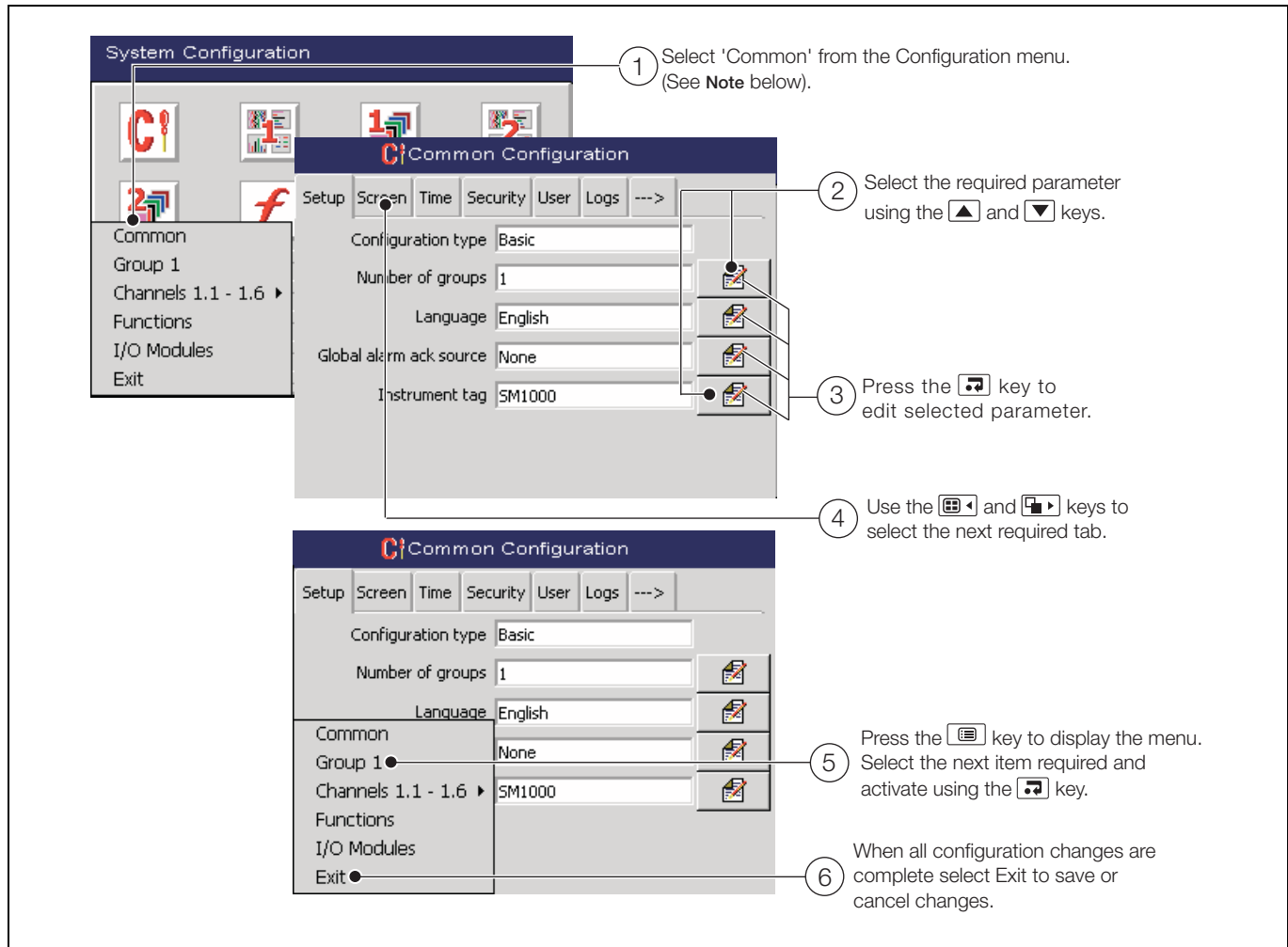

Fig. 4.3 Overview of Configuration Steps

**Note.** Only enabled Process Groups (and their associated Channel Options) are visible in the menu.

### 4.3 Making Changes to Parameters – Figs. 4.5 to 4.7

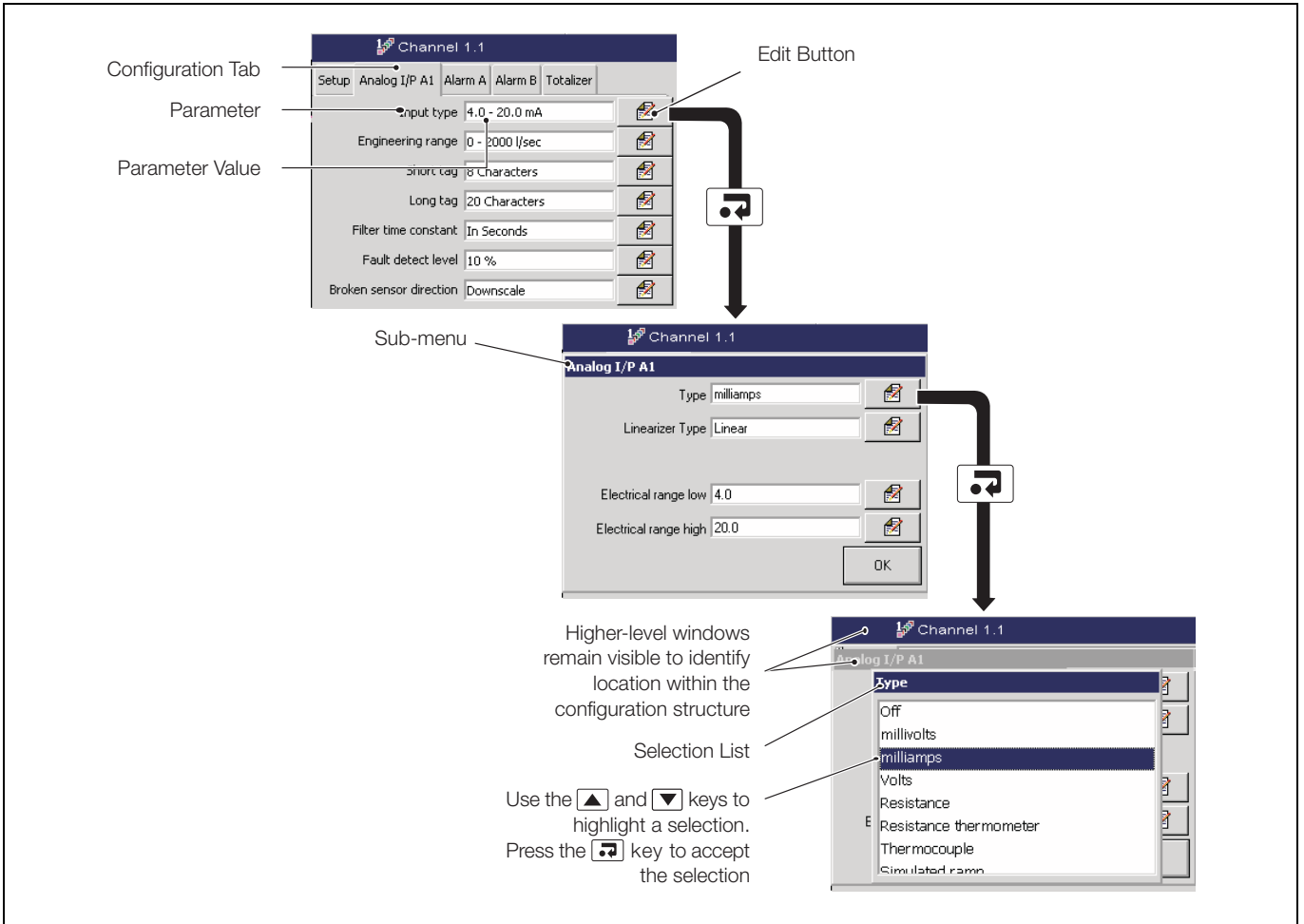

Fig. 4.4 Locating Parameter Settings

**Note.**

- The appropriate data entry box is displayed automatically – see Fig. 4.6
- Use the [F10] key to open the Configuration menu in order to select a different channel – see Fig. 4.11, page 72.

**Process menu enables**

- 1. Message select enable
- 2. Alarm acknowledge enable
- 3. Totalizer reset enable
- 4. Totalizer stop/go enable
- 5. View select enable

OK

Use ▲ and ▼ keys to highlight an item and press to select it.

**Type**

- Off
- millivolts
- milliamps
- Volts
- Resistance
- Resistance thermometer
- Thermocouple
- Simulated ramp

**Note.** Items not selected are indicated by an X in the parameter value window.

1 2 X 4 X

**Parameter Limits**

Electrical low (-100..100 mA)

4.0

7	8	9	-
4	5	6	
1	2	3	C
.	0	Del	OK

Use , , and keys to highlight a character and press to select it.

**Tag**

SM1000

1	2	3	4	5	6	7	8	9	0
A	B	C	D	E	F	G	H	I	J
K	L	M	N	O	P	Q	R	S	T
Del	U	V	W	X	Y	Z			
OK							-->abc..		

Spacebar

**Note.** Values outside the preset parameter limits or with too many decimal places are highlighted when the OK button is selected.

112

Fig. 4.5 Data Entry Dialog Boxes

**Note.** Tags with a high percentage of capital letters and wide characters such as 'W' or 'M' may appear truncated in some Operator Views. In such cases, use lower case letters or fewer characters.

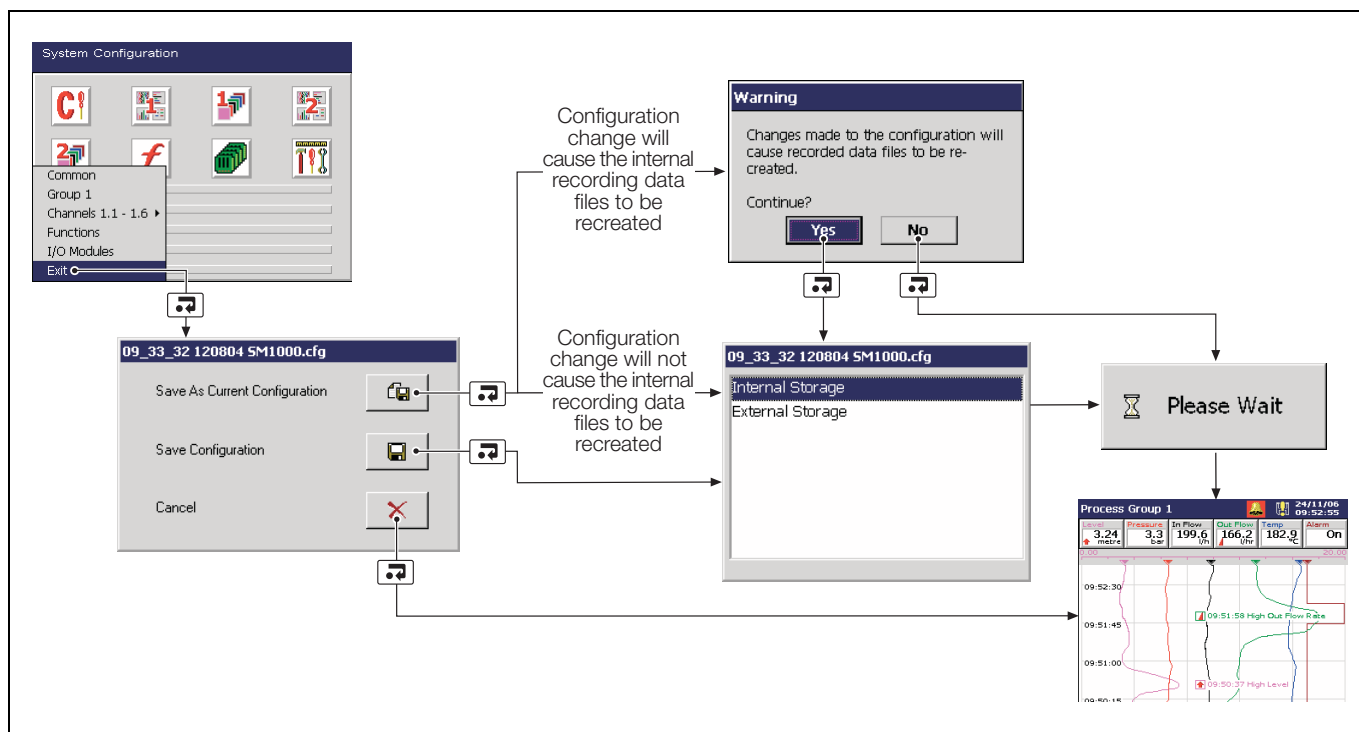

Fig. 4.6 Exiting Configuration Mode

**Note.**

- The current, active configuration is saved to internal storage with the filename 'SM1000.cfg'.
- Selecting 'Save as Current Configuration' suspends recording for a short time while the new configuration is implemented.
- When saving the current configuration to internal storage, the file is saved automatically with the 'SM1000.cfg' filename, and with a '<time><date><instrument tag>.cfg' filename.
- When saving the current configuration to external storage, the file is saved automatically to internal storage with the 'SM1000.cfg' filename, as well as to the external archive media as '<time><date><instrument tag>.cfg'.
- When 'Save Configuration' is selected, the configuration file is stored as '<time><date><instrument tag>.cfg' on internal or external storage.
- Changes are saved to non-volatile memory only when one of the save options above has been selected. Any powerdown before this results in lost configuration changes.
- Selecting 'Cancel' discards unsaved changes and returns the instrument to the Operating level.
- New internal data files for enabled recording channels are created if any of the following configuration parameters are changed:
  - Recording channel source
  - Primary/secondary sample rate
  - Primary/secondary sample rate source
  - Input filter type
  - Engineering range
  - Channel tag
- New internal data files for all enabled recording channels are created if the number of groups is changed, or any previously disabled channel is enabled. Any unarchived data is lost.
- A warning is displayed if a configuration change will result in new internal data files for enabled recording channels being created. Select 'Yes' to accept the configuration change. Select 'No' to cancel the configuration change.

## 4.4 Common Configuration

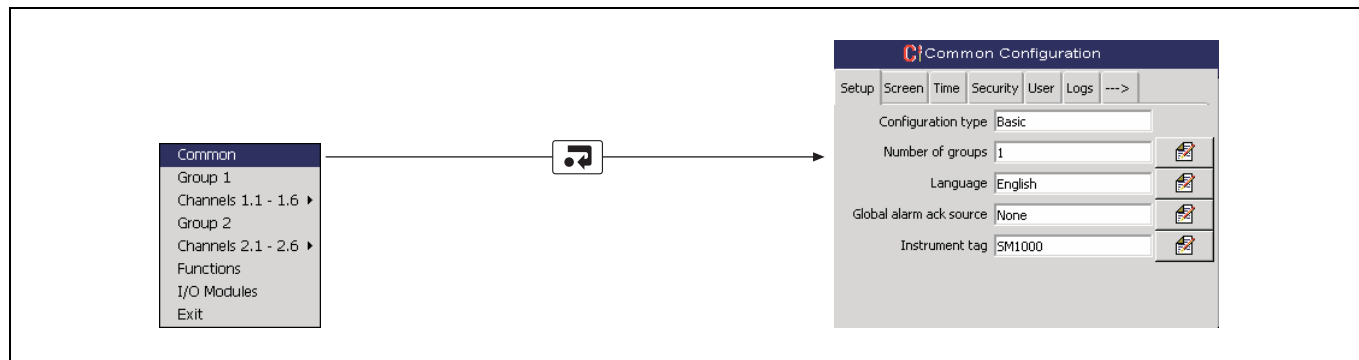

Fig. 4.7 Selecting Common Configuration

### 4.4.1 Setup

Setup Screen Time Security User Logs --->

Configuration type Basic

Number of groups 1

Language English

Global alarm ack source None

Instrument tag SM1000

Configuration type is fixed as 'Basic'.

Enter the number of process groups required.

Each Process Group has 6 recording channels pre-assigned to it – Group 1 (Ch1.1 to 1.6), Group 2 (Ch2.1 to 2.6).

If the Number of Groups is changed from 2 to 1, configuration data for Process Group 2 is retained but not used.

Select the language to be used to display standard user prompts and menu items.

Select a signal source used to acknowledge all active alarms in both Process Groups simultaneously. Refer to Appendix A, page 104 for a description of the available sources.

**Note.** This signal is edge-triggered. A rising edge (inactive to active) or falling edge (active to inactive) triggers global alarm acknowledgement.

•1 Enter the tag to be used to identify the instrument on configuration and audit log files.

**Note.** When reviewing data, the instrument tag is used to identify the source of the data, therefore it is important to ensure that the instrument tag is unique to each recorder.

•1 If this parameter is changed, internally recorded data files are recreated and unarchived data is lost.

#### 4.4.2 Screen



Select the waiting time between the last key press and activation of the screen saver.



When set to 'Enabled', the user can save an image of any Operator screen to external archive media by pressing the  key when an Operator Menu is not open.

**Note.**

- All images are saved to a folder on the archive media named 'BMP'.
- The images are saved even if archiving is set to 'Offline'.
- If external archive media is not inserted, or is full, the screen capture facility is disabled automatically.

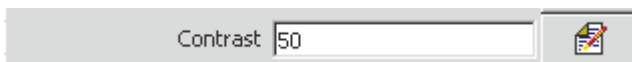

Adjust screen contrast (applicable to recorders fitted with STN display type only).

### 4.4.3 Time

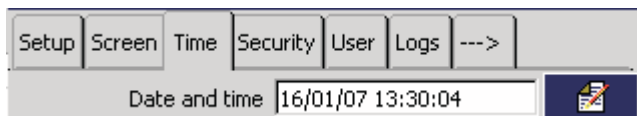

Set the current date and time.

**Note.** If daylight saving is required, enter the settings (see next page) **before** setting the time and date as the operation of the internal clock is affected by the daylight saving settings.

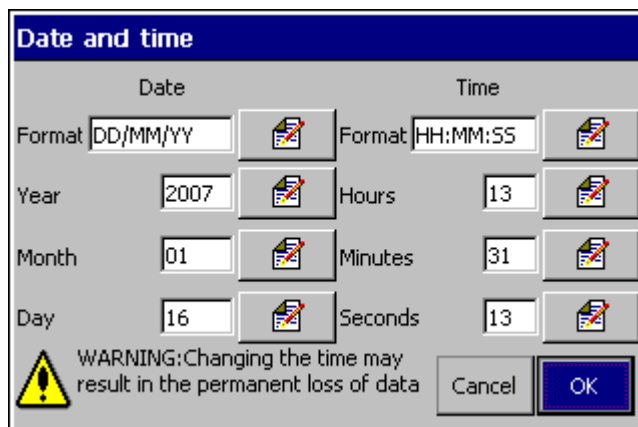

**Note.**

- The date and time cannot be adjusted if recording is enabled during configuration, i.e the 'Disable recording in configuration' check box is **not** ticked on entry to the Configuration level – see Fig. 4.1, page 46.
- Changes to the date and time are effective immediately upon selecting 'OK' in the dialog box above. Selecting 'Cancel' upon exiting Configuration Mode (see Fig. 4.7, page 51) **does not** reset the clock to its previous setting. Select 'Cancel' in the dialog box above to exit date and time setup without saving changes.
- Setting an earlier date or time results in the loss of all data currently in the internal buffer memory past that date. Data archived to external media is unaffected. If an earlier time must be set, change the Instrument Tag (see below). This causes new archive files to be created and the duplicated hour of data is then saved to the new files.
- Time changes due to automatic daylight saving do not affect the recorded data.
- Archive files created during the daylight saving period (see Section 4.5.6, page 70) are compatible with the database feature of Version 5.8 (or later) only of the Company's DataManager data analysis software package.

Daylight Saving - Enable  

Select the daylight saving method.

**Note.** Changes to daylight saving are effective immediately a method is selected. However, if 'Cancel' is selected upon exiting Configuration Mode (see Fig. 4.7, page 51), the last saved daylight saving settings are restored.



Off	Daylight saving is disabled.
Auto - USA	The start and end of the daylight saving period in the USA is calculated automatically.  The clock is incremented automatically by 1 hour at 2:00am on the first Sunday in April and decremented automatically by 1 hour at 2:00am on the last Sunday in October.
Auto - Europe	The start and end of the daylight saving period in Central Europe is calculated automatically.  The clock is incremented automatically by 1 hour at 2:00am on the last Sunday in March and decremented automatically by 1 hour at 2:00am on the last Sunday in October.
Auto - Custom	The start and end of the daylight saving period can be configured manually for regions that do not follow either the USA or Europe conventions.  The clock is incremented automatically by 1 hour at the manually selected start time and decremented automatically by 1 hour at the manually selected end time.

Daylight Saving - Start   
Daylight Saving - End

**Note.** Displayed only if 'Daylight Saving - Enable' is set to 'Auto - USA'.

Daylight Saving - Start   
Daylight Saving - End

**Note.** Displayed only if 'Daylight Saving - Enable' is set to 'Auto - Europe'.

Daylight Saving - Start    
Daylight Saving - End  

**Note.** Displayed only if 'Daylight Saving - Enable' is set to 'Auto - Custom'.

Set the start and end of the daylight saving period.

**Daylight Saving - Start**

Time  

Occurrence  

Day  

Month  

#### 4.4.4 Security

**Note.** User 1 is the System Administrator and is able to change the Security type and all other security parameters. Other users can change only the 'Setup level security' setting and only if 'Security system' is set to 'Basic'.

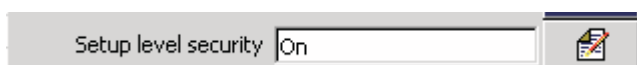

---

Set the Security type.

Select Basic or Advanced security – see Section 4.1.1, page 45.

Set the method of access to the Configuration level.

If 'Password protected' is selected, access is by means of the password set for the user in Section 4.4.6.

**Note.**

- If 'Switch protected' is selected, access to the Configuration level for all users is prohibited once the changes have been saved and made active. Access to the Configuration level is then achieved only by setting the internal security switch to the 'Configuration Level Not Protected' position – see Fig. 4.2, page 47.
- Configuration level security is accessed and modified only by the System Administrator (User 1).

---

When set to 'On', access to the Setup level is password protected.

- If 'Security system' is set to 'Basic', access to the Setup level is protected by a single password for all users.
- If 'Security system' is set to 'Advanced', access to the Setup level is protected by each user's unique password.

---

**Note.** Displayed only if 'Security system' is set to 'Basic' *and* 'Setup level security' is set to 'On' – see above.

Enter the password to be used by all users to access the Setup level.

**Note.** The following parameters:

- are displayed only if 'Security system' is set to 'Advanced' – see page 56.
- can be changed only by the System Administrator (User 1).

Reconfigure preset  

Passwords are entered initially by the System Administrator but, subsequently, any user can change their own password. When this parameter is set to 'Yes', each user must change their password after it is used for the first time following initial configuration – see also Section 4.4.5 on page 58.

Password expiry  

Enter the time period after which all passwords expire. After this period of time, all users must change their passwords.

Inactive user disabling  

Enter the time period after which an inactive user's access privileges are de-activated. A user is considered inactive if their password has not been used. A user is de-activated by removal of their access privileges and can be re-activated only by the System Administrator (User 1).

Password failure limit  

Enter the number of consecutive incorrect password entries allowed by a user. If the number of incorrect entries exceeds this limit, the user's access privileges are de-activated and can be reinstated only by the System Administrator (User 1).

Min password length  

Passwords have a maximum length of 20 characters. Enter the minimum length required for all new passwords.

### 4.4.5 Users

**Note.**

- User 1 is the System Administrator and is able to change user names/access privileges and enter initial passwords for all other users. Other users cannot change their user names and access privileges once set by User 1. All users may change their own passwords.
- The following parameters are displayed only if 'Security system' is set to 'Basic' – see Section 4.4.4, page 56.

A screenshot of the 'User' configuration menu. At the top, there are tabs for 'Setup', 'Screen', 'Time', 'Security', 'User', 'Logs', and '--->'. Below the tabs, there is a list of users:

User 1	Operator 1	
User 2	Operator 2, No access	

Set the user name(s) and associated password(s) to be used to access the Configuration level when 'Configuration security' is set to 'Password protected' – see below.

A screenshot of the 'User 2' configuration dialog box. The title bar says 'User 2'. It contains the following fields:

- Name: Operator 2
- Password: \*\*\*\*\*
- Access: Enabled

Each field has an edit icon to its right. At the bottom right, there is an 'OK' button.

Enter a name for the selected user.

Enter an initial password for the selected user.

Set access privileges for the selected user.

Enabled – The selected user is able to access the Configuration level.

No access – The selected user is unable to access to the Configuration level.

A screenshot of the 'User' configuration menu showing the bottom portion. It lists:

User 3	Operator 3, No access	
User 4	Operator 4, No access	

**Note.** When the method of access to the Configuration level is set to 'Password protected' (see Section 4.4.4, page 56) and a user with Configuration level access privileges changes the instrument's configuration, the 'Name' of the user is included in the audit log entry.

**Note.** The following parameters are displayed only if 'Security system' is set to 'Advanced' – see Section 4.4.4, page 56.

Setup Screen Time Security User Logs --->

User 1 Name Operator 1

User 1 Access Config (Full), Setup,...

User 1 Password \*\*\*\*\*

View/Edit Other Users User 2

User 2 Name Operator 2

User 2 Access Disabled

**ACCESS**

Electronic Signature

Setup

Configuration (No access)

Configuration (Load)

Configuration (Ltd)

Configuration (Full)

OK

User 2 Password \*\*\*\*\*

Configure User 1 (System Administrator)

**Note.** Full Configuration level access privileges for User 1 cannot be disabled but Setup level access and the Electronic Signature privilege may be enabled/disabled as required.

The System Administrator (User 1) can view and/or change the user name, access privileges and password for any other user. Select the user to be viewed/edited.

Enter a name for the selected user.

Set access privileges for selected user.

Electronic Signature – The selected user is able to enter an electronic signature.

Setup – The selected user is able to access the Setup level.

Configuration (No access) (Disabled) – The selected user is unable to access the Configuration and Setup levels or enter electronic signatures.

Config (Load) – The selected user is unable to make any configuration changes but can load configurations from external media.

Configuration (Ltd) – The selected user is able to:

- Change alarm trip points, hysteresis and time hysteresis settings.
- Make input adjustments for analog input boards.
- Load configurations from external media only.

Configuration (Full) – The selected user is allowed full configuration access with the exception of access to the Audit Log size setting and the Security Settings.

**Note.** The System Administrator (User 1) only is able to change the Audit Log size and the Security Settings.

Enter an initial password for the selected user.

**Note.** The user may subsequently change this password.

#### 4.4.6 Logs

Set the maximum number of entries in each instrument log.

**Note.** Changing the log size deletes the current log entries.

The **Alarm Event log** records all process alarm transitions (inactive to active, unacknowledged to acknowledged or active to inactive), real-time events and Operator Messages – see Section 2.7, page 23.

The **Totalizer log** records all activity associated with the totalizers: start, stop, reset, wrap, current total and intermediate totals – see Section 2.8, page 25.

The **Audit log** records all system changes and events – see Section 2.9, page 27.

**Note.**

- The **Totalizer log** is displayed only if the Totalizer option is enabled.
- The size of the **Audit log** can be changed only by the System Administrator (User 1).

Log sizes must be set in the range 10 to 200. The size of the logs has no effect on the amount of memory available for storing channel data.

#### 4.4.7 Operator Messages

Operator messages can be triggered via the Operator Menus or a digital signal.

*Message Tag*

Enter the message text – 20 characters maximum.

*Source ID*

Select a signal source used to add the Operator Message to the Alarm Event log. Refer to Appendix A, page 104 for a description of the available sources.

**Note.** This signal is edge-triggered. A rising edge (inactive to active) or a falling edge (active to inactive) triggers the addition of the Operator Message to the Alarm Event log.

*Assign to group 1/Assign to group 2*

Select the group(s) to which the message is to apply.

### 4.5 Process Group Configuration

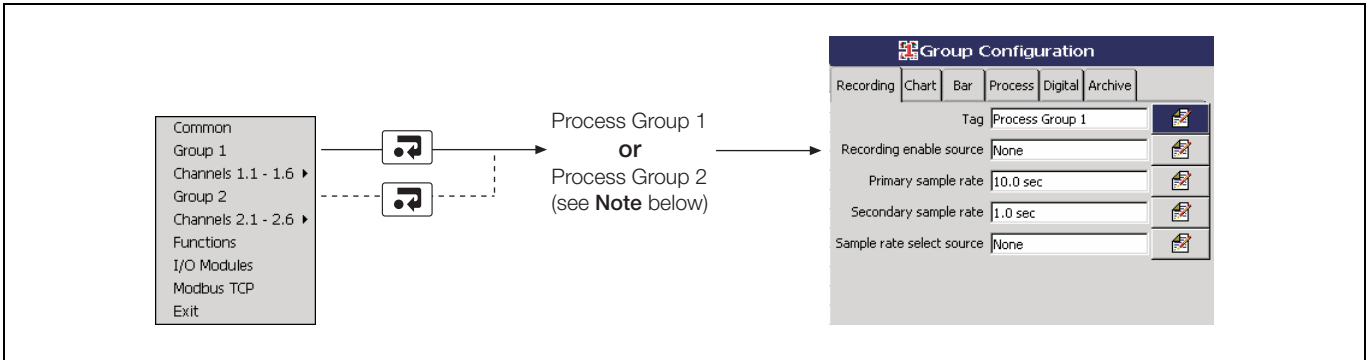

Fig. 4.8 Selecting Process Group Configuration

**Note.** If 'Number of groups' is set to '1' (see Section 4.4.1, page 52), only one Process Group and its associated channels is displayed in the configuration menu.

#### 4.5.1 Setting the Recording Parameters



Enter the process group tag (maximum 20 characters) that appears in the title bar when any operator views from that group are displayed.

**Note.** Each process group tag **must** be unique.

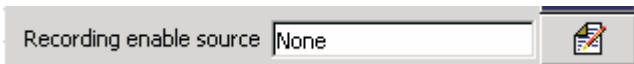

Select a signal source to enable/disable recording of all channels in the current Process Group. Refer to Appendix A, page 104 for a description of the available sources.

**Note.** This signal is edge-triggered. A rising edge (inactive to active) enables recording. A falling edge (active to inactive) disables recording.



The instrument can be configured to sample all recording channels in the group simultaneously and store the data in internal memory and external archive media (if archiving is enabled) at two rates, Primary and Secondary.

The Primary sample rate is active during normal process operating conditions and is set typically to a relatively slow rate (depending upon process recording requirements) in order to maximize internal memory and external archive media capacity.

The instrument can be configured to switch to a faster, Secondary sample rate when a selected digital source becomes active in order to record the maximum amount of detail for the period in which that source is active, or may be switched manually – see Section 3.4, page 32.

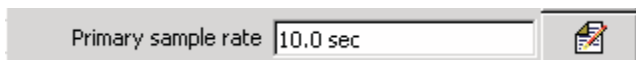

•1

Set the Primary sample rate to between 0.1 seconds and 720 minutes (12 hours). The table below compares example sample rates with the equivalent chart speeds of a traditional chart recorder together with the storage capacity of internal memory. Refer to Appendix C, page 116 for full details of internal memory and external archive media storage capacity.

Sample Rate	Equivalent Chart Speed	On-board Storage Time (6 Channels)
1 second	720mm/h	22.7 hours
3 seconds	240mm/h	2.8 days
6 seconds	120mm/h	5.7 days
12 seconds	60mm/h	11.5 days
36 seconds	20mm/h	1.1 months
72 seconds	10mm/h	2.3 months

**Note.**

- Sample rates are set using one of the following combinations of units:
  - Minutes or minutes and seconds
  - Seconds
  - Tenths of seconds (*minutes and seconds must first be set to zero*).
- The rate at which data is displayed in the Chart Views is set separately – see 'Screen interval' in Section 4.5.2, page 65.
- The fastest sample rate setting determines the maximum screen interval that can be selected – see Table 2.1 on page 12.

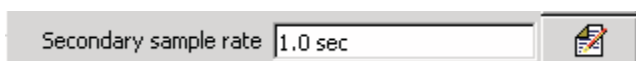

•1

Set the Secondary sample rate to between 0.1 seconds and 720 minutes (12 hours).

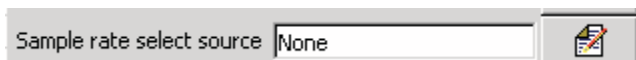

•1

Select a signal source to enable switching between the primary and secondary sample rates. Refer to Appendix A, page 104 for a description of the available sources.

**Note.** This signal is edge-triggered. A rising edge (inactive to active) switches to the secondary sampling rate. A falling edge (active to inactive) switches to the primary sampling rate.



•1 If this parameter is changed, internally recorded data files are recreated and unarchived data is lost.

4.5.2 Configuring the Chart View

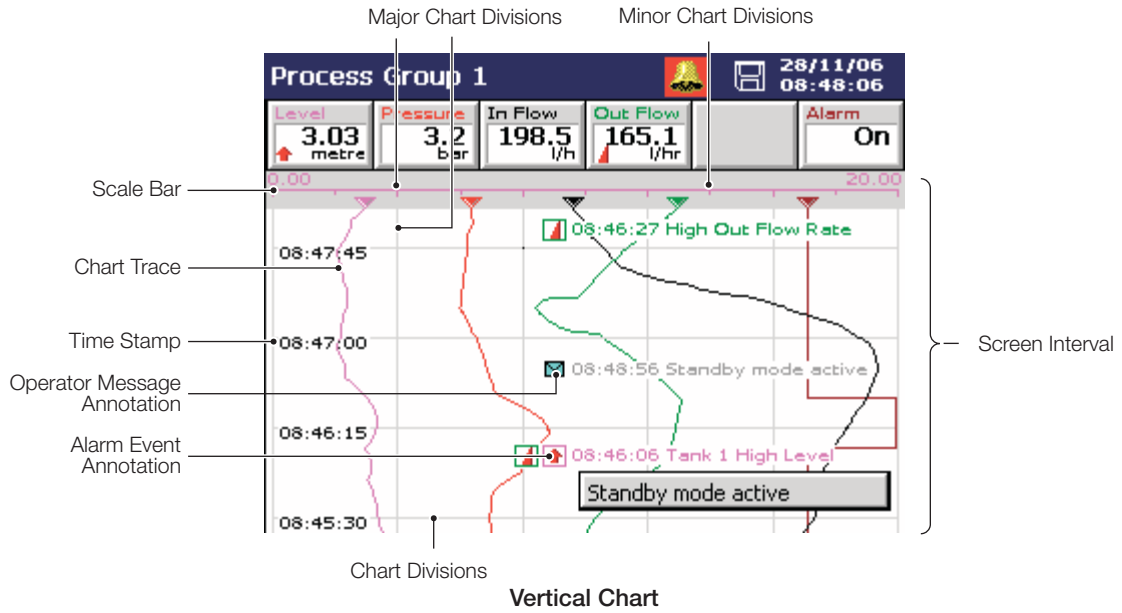

Vertical Chart

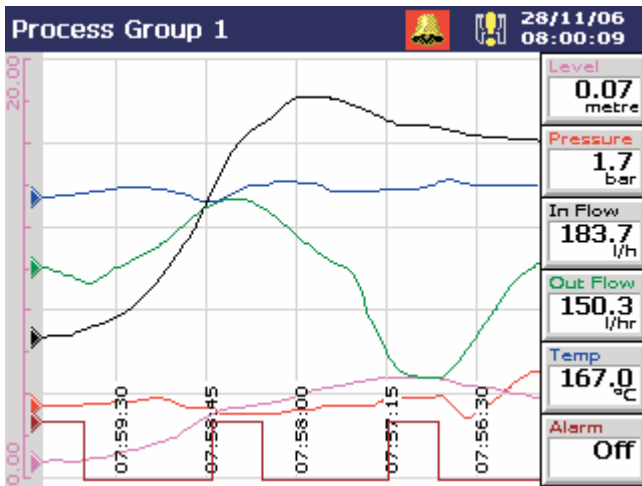

Screen Interval

Horizontal --> Chart

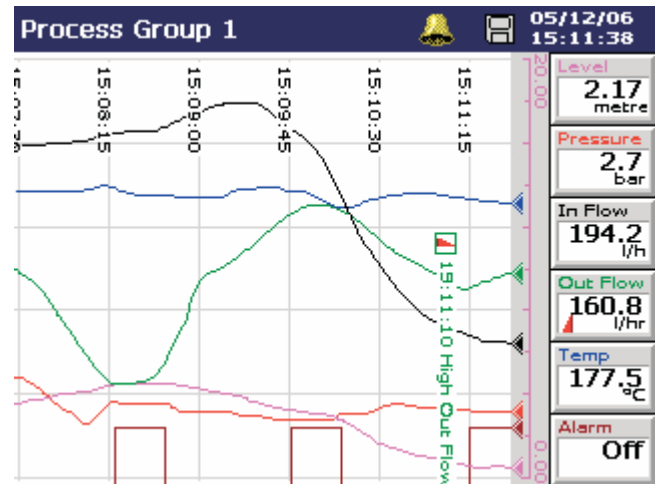

Horizontal <-- Chart

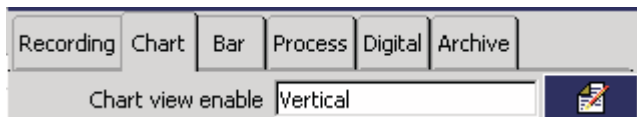

Recording Chart Bar Process Digital Archive

Chart view enable Vertical

Select Horizontal --> (Chart runs left to right with scale bar on left), Horizontal <-- (chart runs right to left with scale bar on right), or Vertical chart view.



Chart annotation Alarms & Op. Messages

Select the annotations to be displayed on the chart. Alarm events and operator messages are displayed on the chart adjacent to the point at which the alarm occurred – see Section 2.3, page 7.

This initial setting can be changed by the operator if 'Chart annotation select enable' is enabled in the Chart view menu enables – see 'Menu Enables' on page 65.

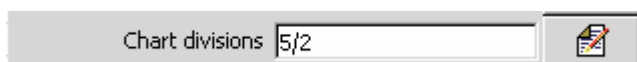
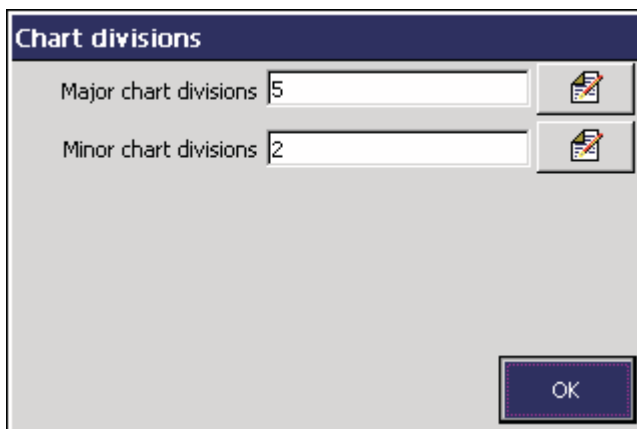

Chart divisions 5/2

Select the number of major and minor chart divisions to be displayed on the chart and its scale bar.



**Chart divisions**

Major chart divisions 5

Minor chart divisions 2

OK

Select the number of major vertical divisions to be displayed.

Select the number of minor vertical divisions to appear between the major chart divisions.

Trace pointers  

Enable trace pointers to display a chart scale bar with pointers to indicate the instantaneous trace positions.



Disable trace pointers to display the standard chart scale bar.

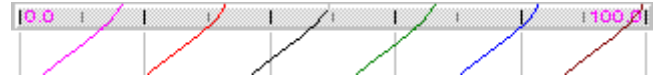

Screen interval  

Select the amount of historical data to be displayed on the screen. Available selections are limited by the sample rate selected – see Section 4.5.1, page 61 and Table 2.1 on page 12.

Trace width  

Select the required trace width in pixels.

Menu enables  

Select the menu items to be accessible from the Chart View.

**Chart menu enables**

- 1. Message select enable
- 2. Alarm acknowledge enable
- 3. Scale select enable
- 4. Trace select enable
- 5. Screen interval select enable
- 6. Historical review enable
- 7. Chart annotation select enable

*Message select enable*

Enables the operator to activate one of 24 pre-configured messages or a user-defined message.

*Alarm acknowledge enable*

Enables the Operator to acknowledge any alarms associated with the current group.

*Scale select enable*

Enables the operator to display the scale for one enabled channel, or all channels in turn, on the scale bar at the top of the screen.

*Trace select enable*

Enables individual chart traces to be displayed or hidden.

*Screen interval select enable*

Enables the Operator to change the amount of data displayed on the screen at one time.

*Historical review enable*

Enables the Operator to scroll back through data recorded previously that is no longer visible on screen.

*Chart annotation select enable*

Enables the display of Alarm events and Operator messages on the chart to be enabled or disabled by the operator.

**Note.** Menu items that are not enabled are greyed-out in the relevant Chart View menu.

4.5.3 Configuring the Bargraph View

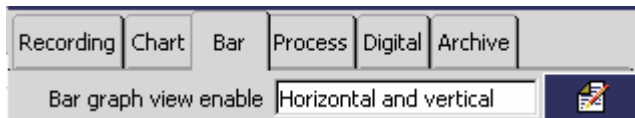
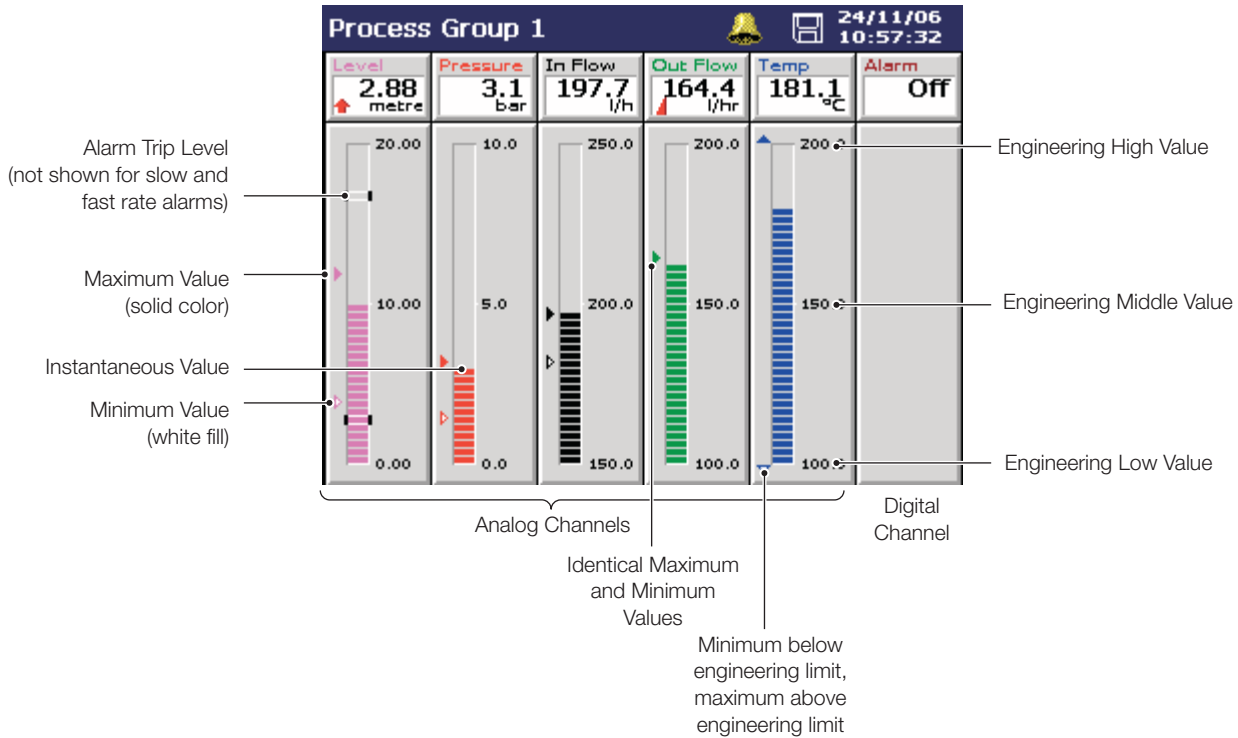

Select the Bargraph views to be displayed in the current Process Group.

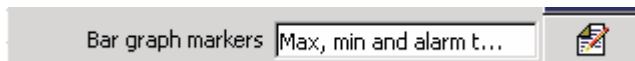

Select the markers (channel-colored max./min. indicators and alarm trip points) to be displayed on the bargraph.

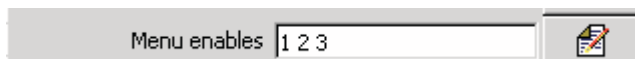

Select the menu items to be accessible from the Bargraph views.

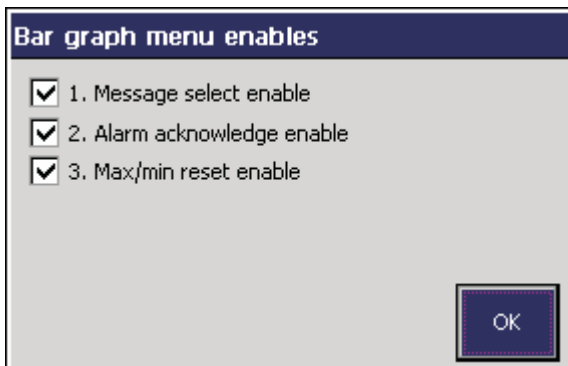

*Message select enable*

Enables the operator to activate one of 24 pre-configured messages or a user-defined message.

*Alarm acknowledge enable*

Enables the Operator to acknowledge any alarms associated with the current group.

*Max/min reset enable*

Enables the operator to reset the maximum and minimum values of one or more channels to the current value.

**Note.** Menu items that are not enabled are greyed-out in the Bargraph menu.

### 4.5.4 Configuring the Process View

**Note.** The Process view is available only if the Totalizer option is enabled.

**Alarms View – Totalizer Enabled**

Totalizer Tag Name Totalizer Value	<table border="1" style="width: 100%; border-collapse: collapse;"> <tr> <td style="width: 50%;"><b>Total Daily In Flow</b> 37692234 m<sup>2</sup></td> <td style="width: 50%;"><b>Low In Flow Rate</b> 40.0</td> </tr> <tr> <td><b>High In Flow Rate</b> 280.0</td> <td style="text-align: right;"><b>In Flow</b> 197.2 l/h</td> </tr> </table>	<b>Total Daily In Flow</b> 37692234 m <sup>2</sup>	<b>Low In Flow Rate</b> 40.0	<b>High In Flow Rate</b> 280.0	<b>In Flow</b> 197.2 l/h	Alarm Acknowledged
<b>Total Daily In Flow</b> 37692234 m <sup>2</sup>	<b>Low In Flow Rate</b> 40.0					
<b>High In Flow Rate</b> 280.0	<b>In Flow</b> 197.2 l/h					
	Alarm Tag      Alarm Trip Level					

**Statistics View – Totalizer Enabled**

<table border="1" style="width: 100%; border-collapse: collapse;"> <tr> <td style="width: 50%;"><b>Total Daily In Flow</b> 37701009 m<sup>2</sup></td> <td style="width: 50%;"><b>Storage 1 In Flow</b> 199.6 l/h</td> </tr> </table>	<b>Total Daily In Flow</b> 37701009 m <sup>2</sup>	<b>Storage 1 In Flow</b> 199.6 l/h	<table border="1" style="width: 100%; border-collapse: collapse;"> <tr> <td style="width: 33%;"><b>Max</b> 200.0</td> <td style="width: 33%;"><b>Min</b> 183.3</td> <td style="width: 33%;"><b>Average</b> 191.0</td> </tr> </table>	<b>Max</b> 200.0	<b>Min</b> 183.3	<b>Average</b> 191.0	Channel Long Tag Name
<b>Total Daily In Flow</b> 37701009 m <sup>2</sup>	<b>Storage 1 In Flow</b> 199.6 l/h						
<b>Max</b> 200.0	<b>Min</b> 183.3	<b>Average</b> 191.0					

Values since last Totalizer Reset or Totalizer wrap.  
Updated only if the Totalizer is Enabled and Running.

**Alarms View or Statistics View – Totalizer not Enabled**

	<table border="1" style="width: 100%; border-collapse: collapse;"> <tr> <td style="width: 50%;"><b>Low In Flow Rate</b> 40.0</td> <td style="width: 50%;"><b>In Flow</b> 189.1 l/h</td> </tr> <tr> <td><b>High In Flow Rate</b> 280.0</td> <td></td> </tr> </table>	<b>Low In Flow Rate</b> 40.0	<b>In Flow</b> 189.1 l/h	<b>High In Flow Rate</b> 280.0		
<b>Low In Flow Rate</b> 40.0	<b>In Flow</b> 189.1 l/h					
<b>High In Flow Rate</b> 280.0						

**Alarms View – Alarms A and B not Enabled**

<table border="1" style="width: 100%; border-collapse: collapse;"> <tr> <td style="width: 50%;"><b>Total Daily In Flow</b> 45183 m<sup>2</sup></td> <td style="width: 50%;"><b>Storage 1 In Flow</b> 195.7 l/h</td> </tr> </table>	<b>Total Daily In Flow</b> 45183 m <sup>2</sup>	<b>Storage 1 In Flow</b> 195.7 l/h		
<b>Total Daily In Flow</b> 45183 m <sup>2</sup>	<b>Storage 1 In Flow</b> 195.7 l/h			

Recording	Chart	Bar	Process	Digital	Archive
Process view enable <input type="text" value="On"/>					

Set to 'On' to enable the operator to display the Process view.

View select <input type="text" value="Statistics"/>
---

Select the Totalizer view to be displayed – Alarms or Statistics. This setting can be changed by the Operator if 'View select enable' is ticked below.

Menu enables <input type="text" value="1 2 X 4 X"/>
---

Select the menu items to be accessible from the Process view.

**Process menu enables**

- 1. Message select enable
- 2. Alarm acknowledge enable
- 3. Totalizer reset enable
- 4. Totalizer stop/go enable
- 5. View select enable

*Message select enable*

Enables the operator to activate one of 24 pre-configured messages or a user-defined message.

*Alarm acknowledge enable*

Enables the Operator to acknowledge any alarms associated with the current group.

*Totalizer reset enable*

Enables the Operator to reset the totalizers on any or all channels.

*Totalizer stop/go enable*

Enables the Operator to stop and start totalizers on any or all channels.

*View select enable*

Enables the Operator to select the Alarms and Statistics views.

**Note.** Menu items that are not enabled are greyed-out in the Process view menu.

### 4.5.5 Configuring the Digital Indicator View

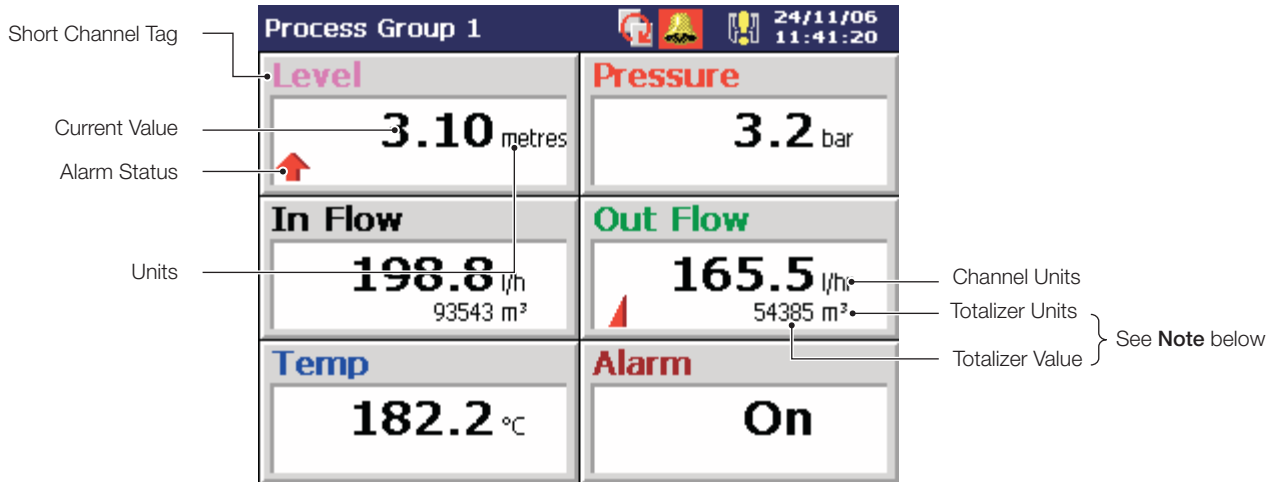

**Note.** Displayed only if the Totalizer option is enabled *and* is enabled for that channel (see Section 4.6.5, page 84) *and* for display (see next page).

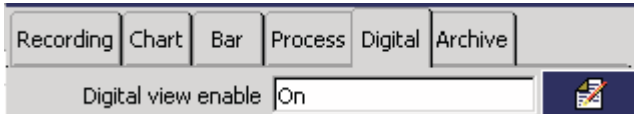

Set to 'On' to enable the operator to display the Digital Indicator view.

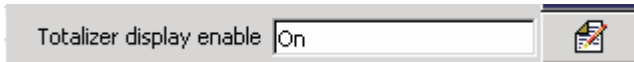

**Note.** This parameter is displayed only if the Totalizer option is enabled.

Set to 'On' to add the channel totalizer value and units to the indicator displays (if the totalizer for that channel is enabled – see Section 4.6.5, page 84).

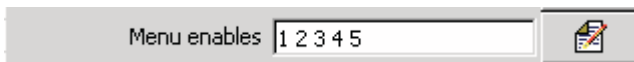

Select the menu items to be accessible from the Digital Indicator view.

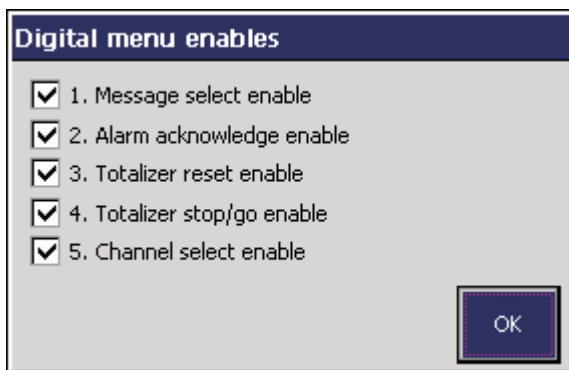

*Message select enable*

Enables the Operator to activate one of 24 pre-configured messages or a user-defined message.

*Alarm acknowledge enable*

Enables the Operator to acknowledge any alarms associated with the current group.

*Totalizer reset enable*

Enables the Operator to reset the totalizer value to the preset totalizer value on any or all channels.

*Totalizer stop/go enable*

Enables the Operator to start and stop the totalizer.

*Channel select enable*

Enables the Operator to display or hide individual channels.

**Note.**

- Menu items that are not enabled are greyed-out in the Digital Indicator View menu.
- Totalizer menu items can be enabled only if the Totalizer option is enabled.

### 4.5.6 Archiving

#### Introduction

Recorded data, logs and configuration files stored in the instrument's internal memory can be archived to files created in removable media in either text or binary encoded format. Parameters for archiving Process Group 1 are set up independently from Process Group 2 parameters.

For a full description of archiving and archive file formats, refer to Sections 3.5 to 3.10.

#### Sample Rates – Fig. 4.10

Data is saved to the archive file at the same rate as it is saved to internal memory, i.e. at either the Group's primary or secondary recording sample rate.

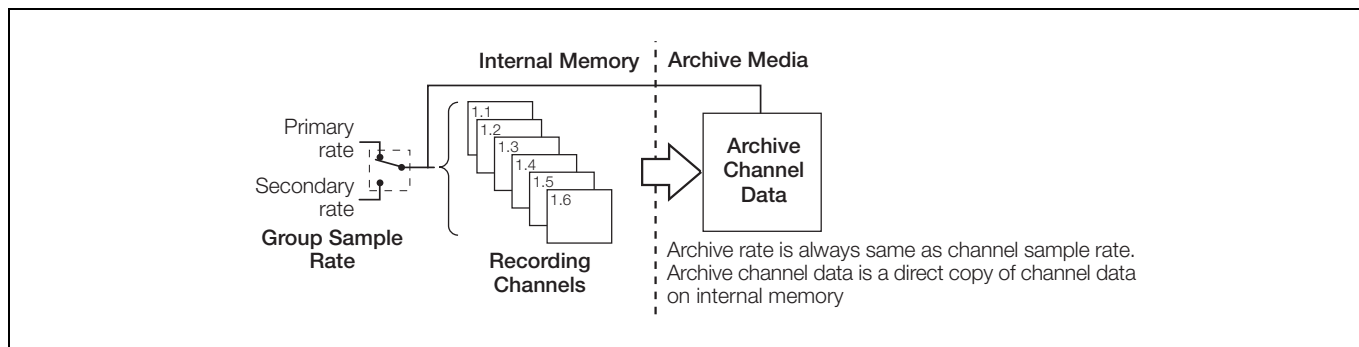
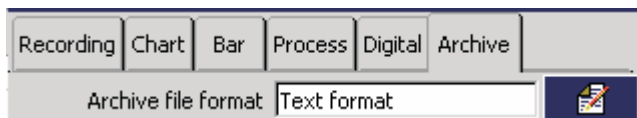
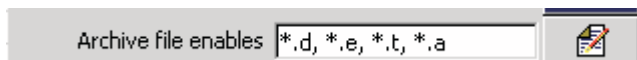

Fig. 4.9 Archiving Sample Rates



Select the archive file format required – Text format or Binary format.

**Note.** The selected archive file format is applied automatically to **both** process groups. It is not possible to set each group to different formats.



Select the data types that are to be archived to the storage media: Channel Data; Alarm Event log; Totalizer log; Audit log.

**Note.** The totalizer log file can be enabled only if the totalizer option is enabled.

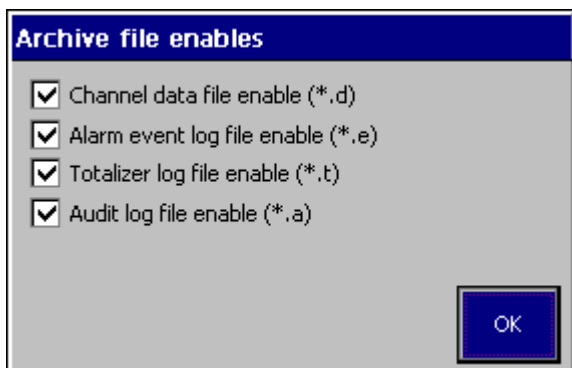

File Type	Contents	Extension
Channel data files	Analog or digital recording channel signals in the current process group	*.D00 (Text) or *.B00 (Binary)
Alarm event log files	The historical record of the alarm events related to the group's channels plus the history of any operator messages, electronic signatures or real time alarms.	*.E00 (Text) or *.EEO (Binary)
Totalizer log files	The historical record of all totalizer and associated statistical values relating to the group's recording channels.	*.T00 (Text) or *.TEO (Binary)
Audit log files	The historical entries in the audit log.	*.A00 (Text) or *.AEO (Binary)

Filename tag  

**Note.** Displayed only if 'Archive file format' (previous page) is set to 'Text format'.

Enter the filename (max. 20 characters) to be used to identify the channel data archive files.

**Note.** The following characters cannot be used in the filename tag: \, /, :, \*, ?, ", <, >, |, superscript characters, ~, Ω and °. These are greyed-out on the keyboard.

New file interval  

**Note.** Displayed only if 'Archive file format' (previous page) is set to 'Text format'.

Set the frequency with which new channel data files are created.

**Note.** Set automatically to 'Off' if 'Wrap' (see below) is set to 'On'.

New File Interval	Filename
Hourly	<hour> <day, month, year>* <filename tag>
Daily	<day, month, year>* <filename tag>
Monthly	<month, year>* <filename tag>
None	<filename tag>

\*Formatted according to the date format set in Common Configuration – see Section 4.4.3, page 54.

Wrap  

When set to 'On', archive wrap deletes the oldest archived data file from external archive media automatically when the media approaches its maximum capacity.

When set to 'Off', archiving stops automatically when external archive media is full. No files are deleted.

Archive Triggers	Oldest Un-archived Data	
	<1 Day Old (Binary) or <1 Hour Old (Text)	>1 Day Old (Binary) or >1 Hour Old (Text)
'Online' request from the Set up menu.	Any un-archived data is stored automatically to the removable archive media.	All the un-archived data within the selected time frame is archived. Older un-archived data remains in the internal memory buffer until overwritten by newer data but is not available for archiving to removable media.
Automatic update	Any un-archived data is saved to removable archive media at regular intervals (approximately every 30 seconds).	Not Applicable

Table 4.1 Archive Triggers

## 4.6 Channel Configuration

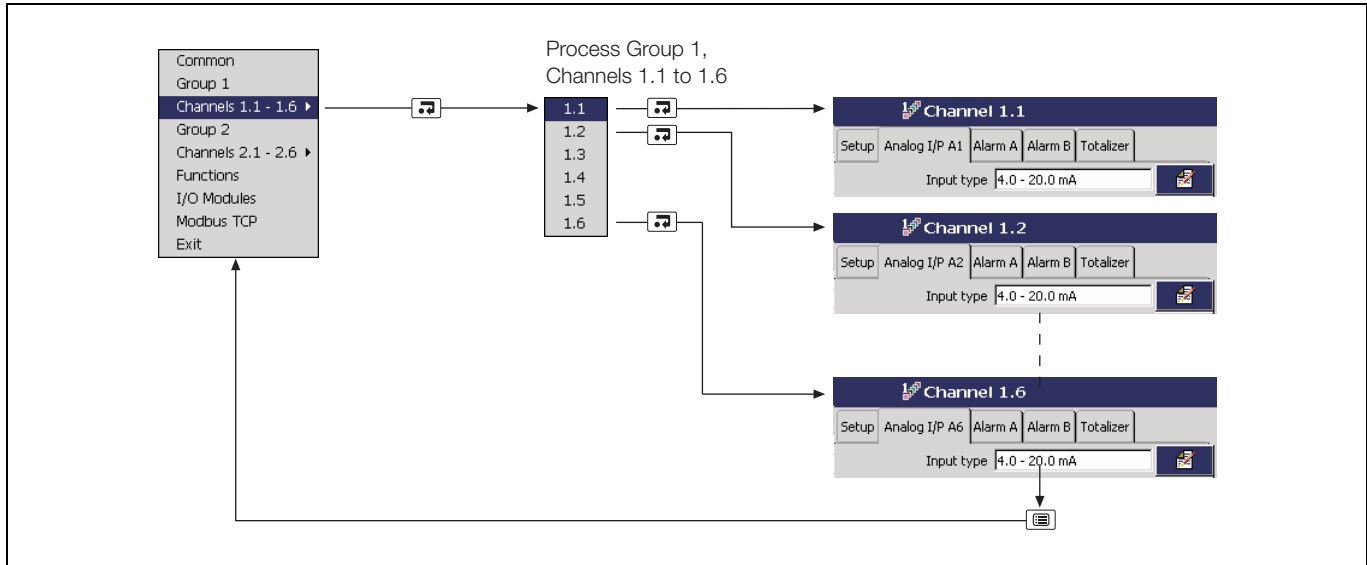
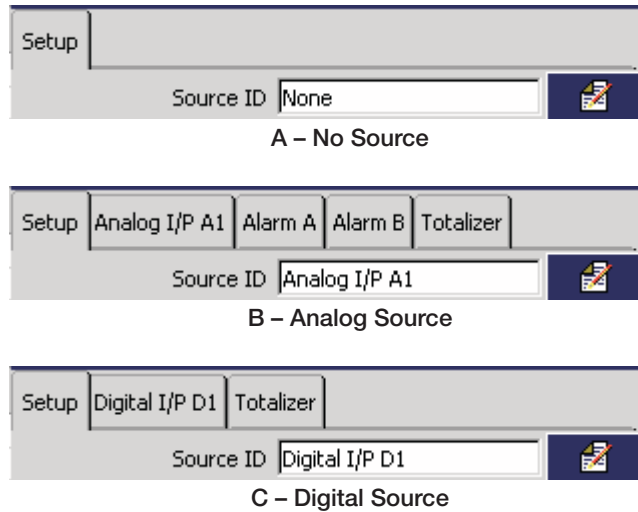

Fig. 4.10 Recording Channel Configuration

### 4.6.1 Recording Channel Setup



- 1 Select the signal source for the selected channel. This can be any external analog or digital signal – see Appendix A, page 104 for full list.

**Note.**

- The input source for Channel 1 in any process group **must** be an analog input to ensure correct operation of the recorder.
- The tabs change according to the selection made.
- Setting a channel source to 'None' does not switch off the analog input to which the channel was assigned previously i.e. the analog input continues to be monitored. To switch off an analog input, set Analog I/P 'Type' for the required channel to 'Off' – see Section 4.6.2, page 74.

- 1 If this parameter is changed from any previous setting other than 'None', a new internal data file for this recording channel is created. All historical data stored internally for this channel is lost. If this parameter is changed from a previous setting of 'None' new internal data files for all enabled recording channels are created. Any unarchived data is lost.

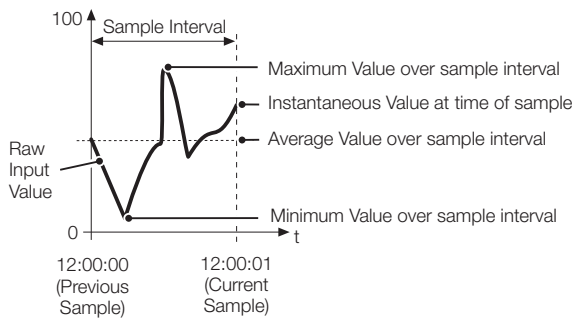

Each recording channel can be configured to position its trace in a specific zone in the chart views in order to separate traces that would otherwise be very close to each other.

**Note.** The trace colors cannot be changed. The trace colors are:

1st	2nd	3rd	4th	5th	6th
Magenta	Red	Black	Green	Blue	Brown

Select one of the 15 pre-defined zones available.

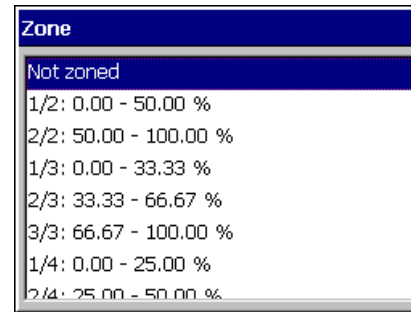

•1 Select the filter to be applied to the electrical input prior to sampling.

**Note.**

- Applicable to analog sources only.
- Filters are applied to the recorded values shown on the chart view only, not to instantaneous values displayed on the channel indicators or bargraphs.

Instantaneous – A single value based on process conditions at the time of sampling.

Average – The average value of the analog signal since the previous sample.

Minimum – The minimum value of the analog signal since the previous sample.

Maximum – The maximum value of the analog signal since the previous sample.

Max & min – Two values are recorded to capture the maximum & minimum signal values since the previous sample. This allows the memory use to be extended by permitting a slower sample rate to be selected without losing the transient behavior of the signal.

•1 If this parameter is changed, internally recorded data files are recreated and unarchived data is lost.

## 4.6.2 Analog Input Configuration

### Note.

- The 'Analog I/P' tab is displayed only if 'Source ID' for the Recording Channel is set to an analog signal source – see Section 4.6.1, page 72.
- If an analog input is assigned to more than one recording channel, changes to any of its parameters and tags are applied to each channel the input is assigned to.
- If an analog input is already assigned to another channel, the edit keys () are not available.

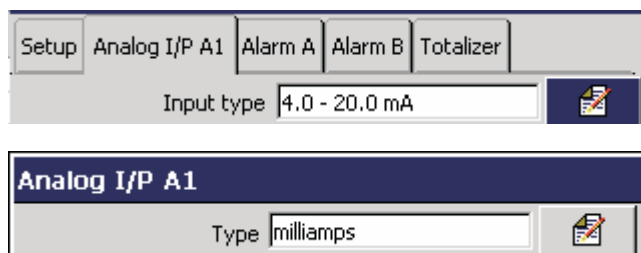

- 1 Select the electrical characteristics of the input.



### Note.



- Simulated input types are available for evaluating instrument features without the need for process connections.
- If 'Volt free digital input' is selected, the input channel becomes a digital input channel – see Section 4.6.3, page 77.
- Select 'Off' to disable an analog input.

### Warning.

- Ensure that the appropriate electrical connections have been made – see Section 5.4, page 100.
- When 'Type' is set to 'Volts', input signals with voltages greater than 2V (standard inputs) or 1V (high specification inputs) **must** be connected through an external voltage divider (part no. GR2000/0375) – see Section 5.4.1, page 100.
- Input signals with voltages up to 2V (2000mV – standard inputs) or 1V (1000mV – high specification inputs) may be measured without the need for the voltage divider by setting 'Type' to 'millivolts'.
- An external 10 $\Omega$  shunt resistor is required for current ranges – see Section 5.4.1, page 100.

- 1 If this parameter is changed to or from 'Volt free digital input', internally recorded data files are recreated and unarchived data is lost.

Linearizer Type	Pt 100	
Linearizer units	Degrees C	

Electrical range low	4.0	
Electrical range high	20.0	
		

Select the linearizer type and the units used to condition the input signal before it is sampled.

**Note.**

- For thermocouple applications using an external fixed cold junction, set 'Type' to 'millivolts' and select the appropriate linearizer type.
- Linearizer units are displayed only if a temperature linearizer type (Thermocouple or RTD) is selected.

Set the required electrical range.

**Note.**

- Applicable only to mA, mV, V and Resistance input types.
- When an input is connected through an external voltage divider (see **Warnings** on page 74), set the electrical range low and high values to the actual voltage applied to the divider, not the voltage after it has been divided down. The range of the electrical input signal is determined by the input type – see Table 4.2:

Input Type	Standard Inputs				High Specification Inputs			
	mV	V	mA	Ω	mV	V	mA	Ω
Min.	0	0	0	0	-1000	-50	-100	0
Max.	2000	20	50	5000	1000	50	100	2000

Table 4.2 Limits of Electrical Ranges

Engineering range  

**Engineering range**

Low  

High  

Units  

- 1 Specify the display range and units of the engineering value corresponding to the electrical high and low values, within the limits defined in Table 4.3:

THC/RTD Type	°C		°F	
	Min.	Max.	Min.	Max.
Type B	-18	1800	0	3270
Type E	-100	900	-140	1650
Type J	-100	900	-140	1650
Type K	-100	1300	-140	2350
Type L	-100	900	-140	1650
Type N	-200	1300	-325	2350
Type R & S	-18	1700	0	3090
Type T	-250	300	-400	570
Pt100	-200	600	-325	1100
Power 5/2 Power 3/2 Square Root Custom Linearizer 1 Custom Linearizer 2 Linear	-999 to +9999			

Table 4.3 Limits of Engineering Ranges

**Example** – for an electrical input range of 4.0 to 20.0mA, representing a pressure range of 50 to 250 bar, set the 'Low' value to 50.0 and the 'High' value to 250.0.

Short tag  

- 1 Enter the tag name to be displayed on channel indicators and used to identify the channel in archive files (8 characters max.).

**Note.** Tags with a high percentage of capital letters and wide characters such as 'W' or 'M' may appear truncated in some Operator Views. In such cases, use lower case letters or fewer characters.

Long tag  

- 1 Enter the tag name to be displayed in the Process view and used in the archive files (20 characters max.).

•1 If this parameter is changed, internally recorded data files are recreated and unarchived data is lost.

Filter time constant  

Set the time period over which the process variable is to be filtered prior to being sampled (0 to 60 seconds).

Fault detect level  

Set a tolerance level (between 0 and 100% of the engineering range) to allow for deviation of the input signal above or below the input span before an input failure is detected.

**Example** – setting the fault detection level to 10% on an input range of 50 to 250 bar causes an 'Analog Input Failure' fault to be detected below 30 bar and above 270 bar.

Broken sensor direction  

In the event of an input failure, recorder channels can be set to drive upscale, downscale or in the direction of failure.

- Upscale – channel value driven beyond full scale.
- None – driven in direction of failure.
- Downscale – channel value driven below zero.

### 4.6.3 Digital Input Configuration

**Note.** The 'Digital I/P' tab is displayed only if 'Source ID' for the Recording Channel is set to a digital signal source – see Section 4.6.1, page 72.

Setup Digital I/P A1 Totalizer  

- 1 **Note.** This parameter is displayed only if 'Input type' on the 'Analog I/P' tab is set to 'Volt free digital input'. If this parameter is changed to anything other than 'Volt free digital input', the input channel reverts to an analog input channel – see Section 4.6.2, page 74.

Digital on tag  

- 1 Enter the tag to be displayed on channel indicators when the digital signal is active (6 characters max.).

**Note.** Tags with a high percentage of capital letters and wide characters such as 'W' or 'M' may appear truncated in some Operator views. In such cases, use lower case letters or fewer characters.

Digital off tag  

- 1 Enter the tag to be displayed on channel indicators when the digital signal is inactive (6 characters max.).

Short tag  

Enter the tag name to be displayed on channel indicators and used to identify the channel in archive files (8 characters max.).

**Note.** Tags with a high percentage of capital letters and wide characters such as 'W' or 'M' may appear truncated in some Operator views. In such cases, use lower case letters or fewer characters.

Long tag  

Enter the tag name to be displayed in the Process view and used in the archive files (20 characters max.).

- 1 If this parameter is changed, internally recorded data files are recreated and unarchived data is lost.

### 4.6.4 Alarm Configuration

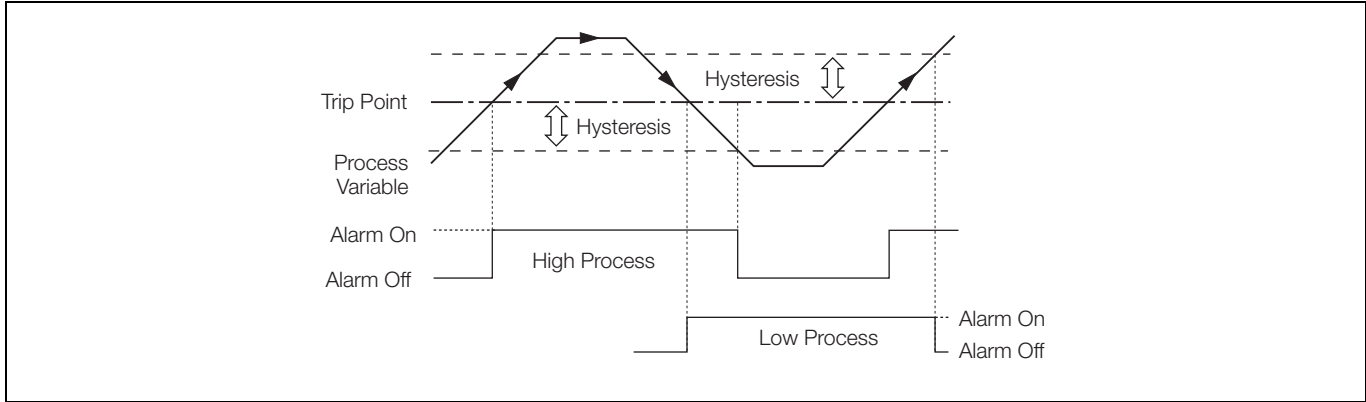

Fig. 4.11 High/Low Process Alarms

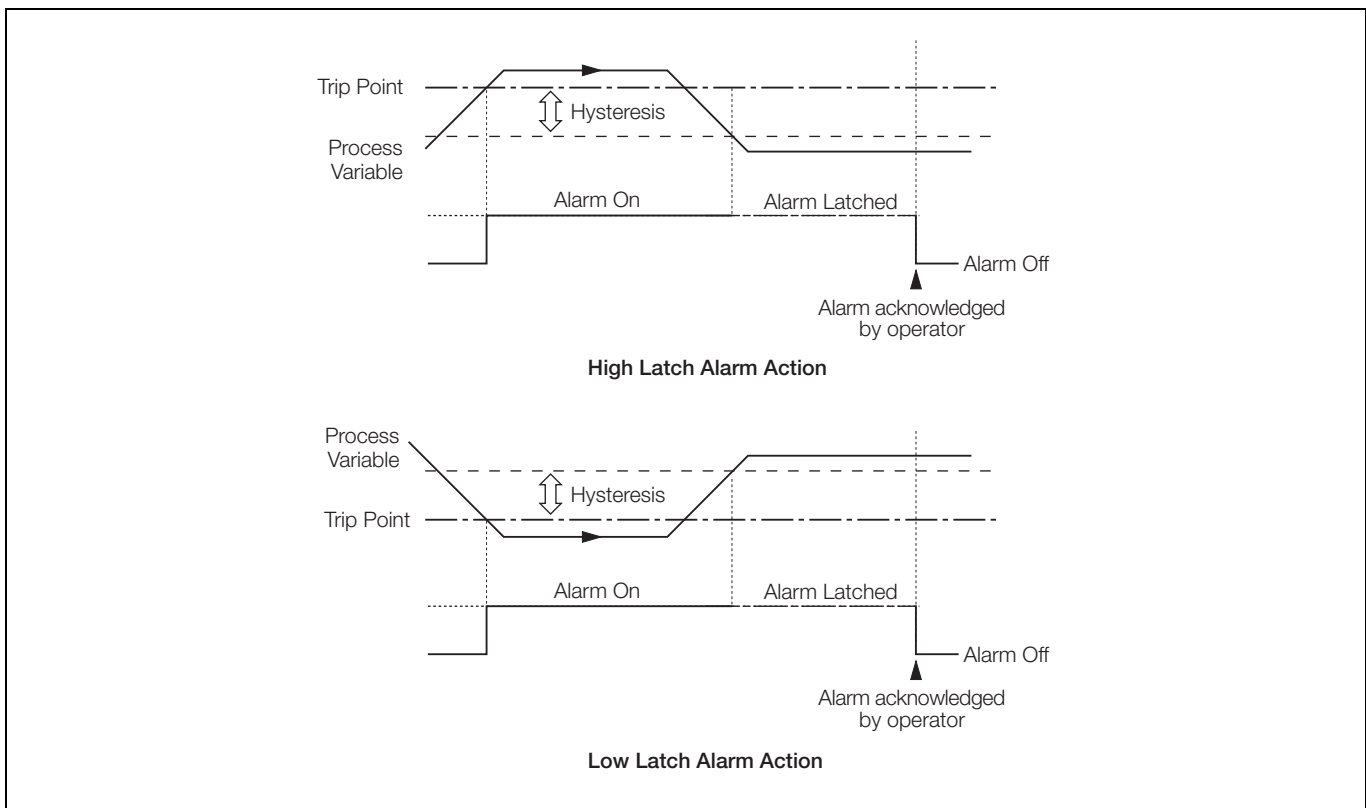

Fig. 4.12 High/Low Latch Alarms

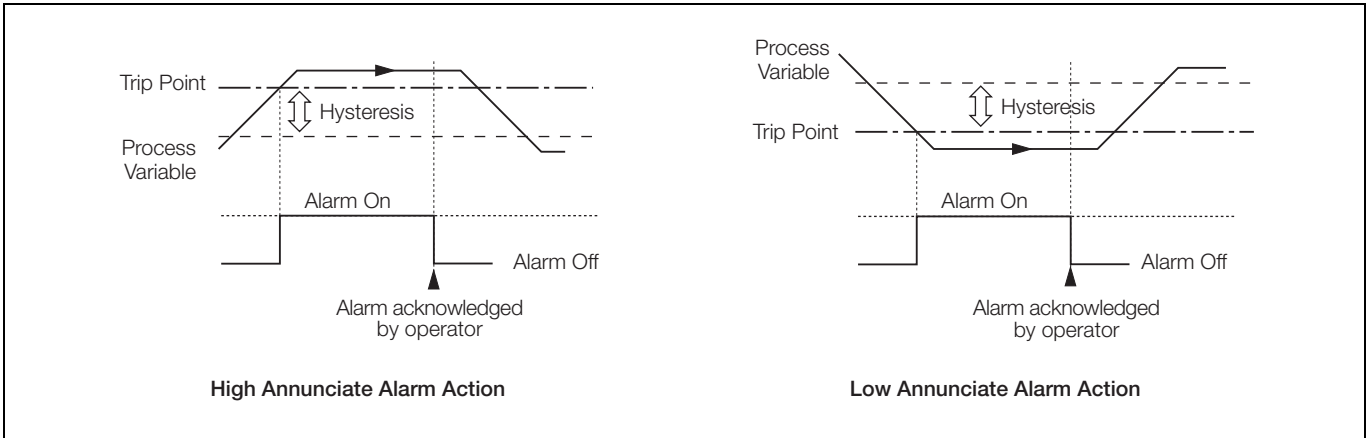

Fig. 4.13 High/Low Annunciate Alarms

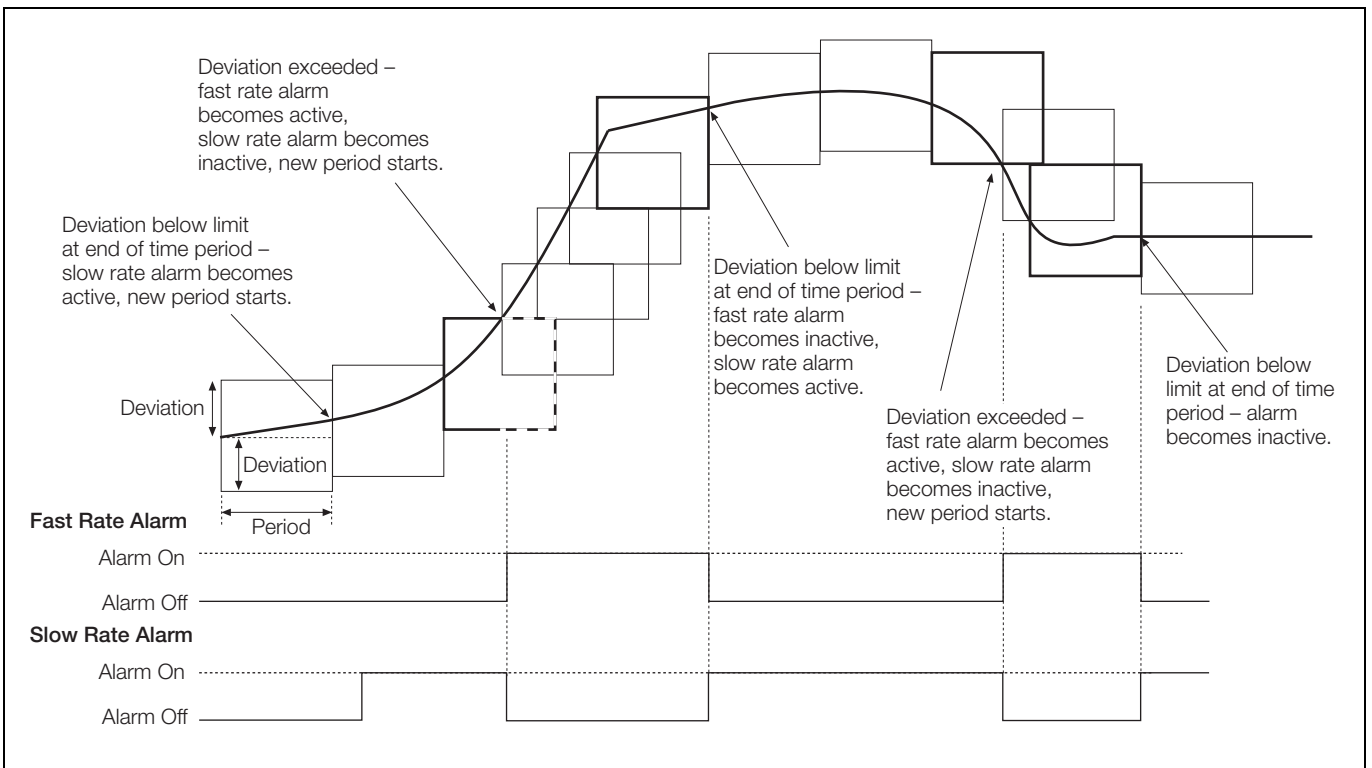

Fig. 4.14 Fast-/Slow-Rate Alarms

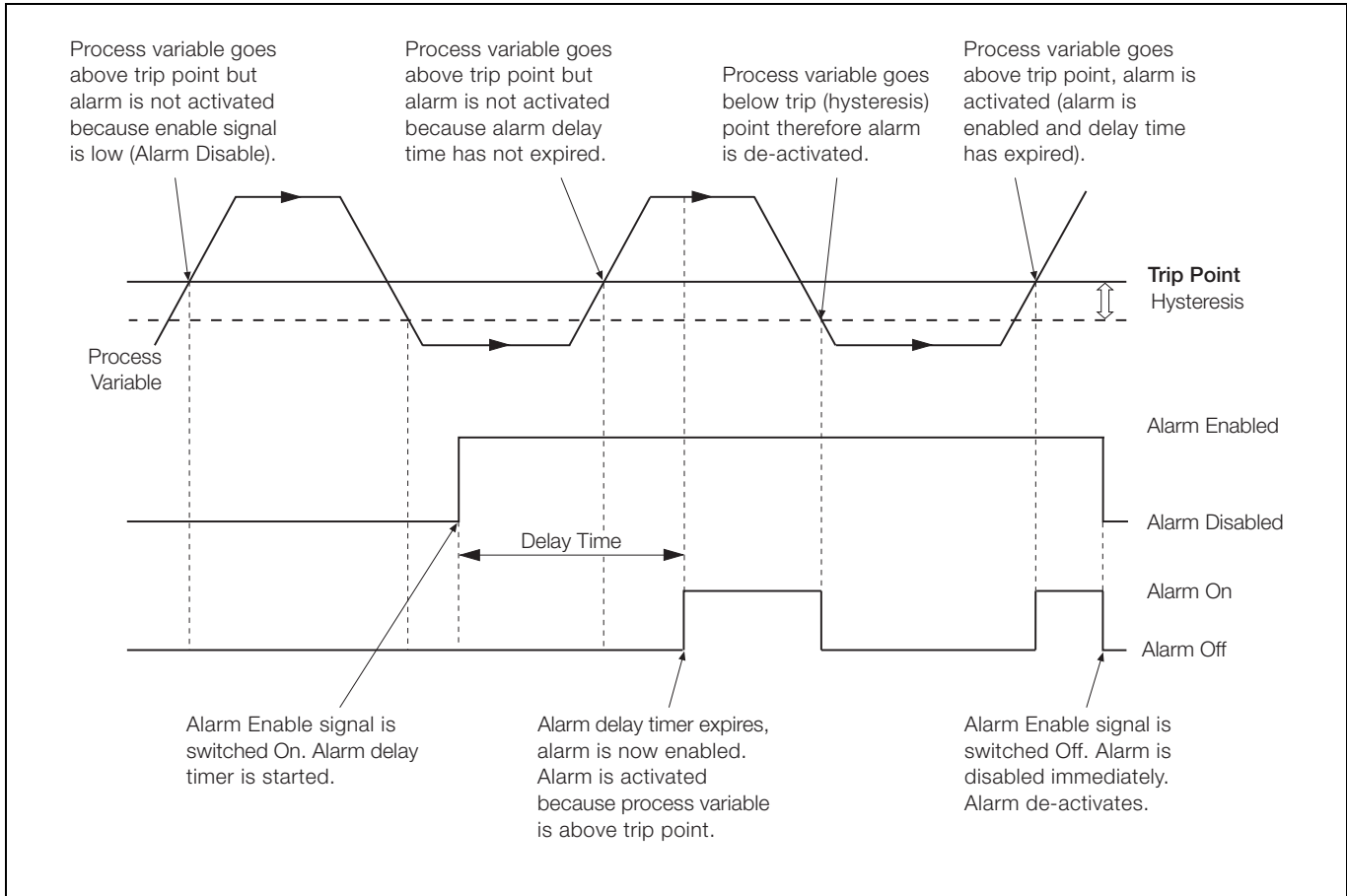

Fig. 4.15 Delayed High/Low Process Alarms

**Note.** The Alarm Configuration tabs are displayed only if 'Source ID' for the Recording Channel is set to an analog signal source – see Section 4.6.1, page 72.

Setup Analog I/P A1 Alarm A Alarm B Totalizer

Alarm type High process

Alarm tag 1.1A

Trip 200.0 %

Hysteresis 25.0 %, 0 Secs

Hysteresis 25.0 %

Time hysteresis 0 Secs

OK

Trip 10.0 %

Time hysteresis 0 Secs

Set the alarm type:

- High/Low process – see Fig. 4.12, page 78
- High/Low latch – see Fig. 4.13, page 78
- High/Low annunciate – see Fig. 4.14, page 79
- Fast/Slow rate – see Fig. 4.15, page 79
- Delayed high/low process – see Fig. 4.16, page 80

Enter an Alarm Tag to identify the alarm when it is displayed in the Chart, Process and Alarm Event views (20 characters max.).

**Note.** Process and Latch alarms only – see Figs 4.12 and 4.13.

Set the value, in engineering units, at which the alarm is to activate.

Set the hysteresis value in engineering units and the time hysteresis in seconds.

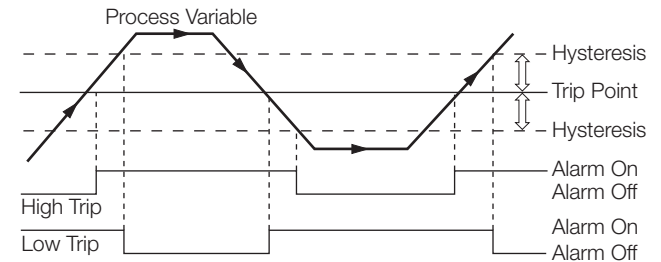

When an alarm trip value is exceeded, the alarm does not become active until the time hysteresis value has expired. If the signal goes out of the alarm condition before the time hysteresis has expired, the hysteresis value is reset.

**Note.** Annunciate alarms only – see Fig. 4.14.

Set the value, in engineering units, at which the alarm is to activate.

Set the time hysteresis in seconds.

Trip

Hysteresis/Delay time

Hysteresis

Time hysteresis

**OK**

Deviation/Period

Deviation

Period

**OK**

Rate filter

**Note.** Delayed process alarms only – see Fig. 4.16.

Set the value, in engineering units, at which the alarm is to activate.

Set the hysteresis value in engineering units and the delay time in seconds.

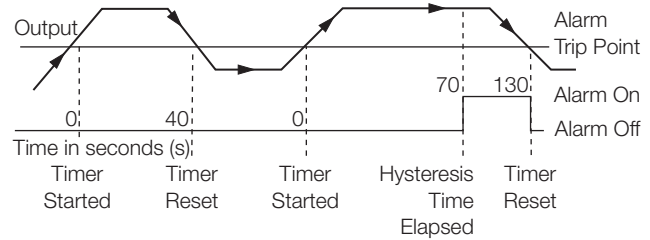

The delay time is the period of time for which alarm activation is delayed after the enable signal is switched on. Once the delay time has expired, the alarm operates in the same way as a standard High/Low process alarm.

**Note.**

- Rate alarms only – see Fig. 4.14.
- A Rate alarm remains active until the rate has been within limits for at least one complete Alarm Period.

Set the minimum or maximum amount of deviation allowed within the Rate Alarm Period before the alarm is activated.

Set the time period over which the deviation is measured. For High Rate alarms, the alarm becomes active if the value changes by more than the deviation value within the alarm period. For Low Rate alarms, the alarm becomes active if the channel value changes by less than the deviation within the alarm period.

Set the filter time to be used to reduce the number of spurious alarm trips. The source signal is averaged over the filter period prior to the rate alarm being determined.

Enable source  

Select an alarm Enable source. When the 'Enable source' is active, the alarm is enabled. When the source is inactive the alarm is disabled. If set to 'None' the alarm is always enabled.

**Note.** For Delayed Process alarm operation, see Fig. 4.16, page 80.

Log enable  

Set to 'On' to record all changes in the alarm state in the Alarm event log – see Section 2.7, page 23.

Alarm group  

Assign the alarm to one or more of 12 groups.

**Alarm group**

<input checked="" type="checkbox"/> Group 1	<input type="checkbox"/> Group 8
<input checked="" type="checkbox"/> Group 2	<input type="checkbox"/> Group 9
<input type="checkbox"/> Group 3	<input type="checkbox"/> Group 10
<input type="checkbox"/> Group 4	<input type="checkbox"/> Group 11
<input type="checkbox"/> Group 5	<input checked="" type="checkbox"/> Group 12
<input checked="" type="checkbox"/> Group 6	
<input type="checkbox"/> Group 7	

The alarm states assigned to each group are 'ORed' together to create an internal digital signal that may be assigned to relays, digital outputs or internal digital controls.

### 4.6.5 Totalizer Configuration

**Note.**

- The totalizer tab is displayed only if the Totalizer option is enabled.
- Current totalizer values are displayed in the Digital Indicator and Process Views – see Sections 2.5 and 2.6 (Operation), and Sections 4.5.5 and 4.5.4 (Configuration) respectively.
- For analog sources, the total value of a signal is calculated by counting pulses produced at a rate proportional to the input. For digital sources, off/on transitions are counted to produce a batch total.

Select the totalizer Count direction and Wrap action.

When the count direction is set to 'Up', the totalizer counts up from the 'Preset count' value to the 'Predetermined count' value – see next page.

If 'Wrap enable' is set to 'On', the total is reset automatically to the 'Preset count' value once the 'Predetermined count' value is reached.

If 'Wrap enable' is set to 'Off', the count stops when the 'Predetermined count' value is reached.

**Note.** A wrap pulse, with a duration of 2s, occurs if the total reaches the 'Predetermined count' value and 'Wrap enable' is set to 'On'. If 'Wrap enable' is set to 'Off', the wrap pulse becomes active when the 'Predetermined count' value is reached and remains active until the totalizer is reset. The pulse can be assigned to a relay, digital output or digital counter.

Enter the totalizer tag to be displayed in the Process view and the Totalizer log (20 characters max).

Enter the totalizer units to be displayed in Operator views.

Select the totalizer action following a power failure:

*Stop/Go recovery*

Last – On power recovery, the totalizer continues in the same state as before the failure, i.e. stopped or running.

Stop – Totalizer stops counting.

Go – Totalizer starts counting from the last recorded value.

*Stop/Go source*

Select a signal source to stop and start the totalizer. Refer to Appendix A, page 104 for a description of the available sources.

**Note.** This signal is edge-triggered. A rising edge (inactive to active) starts the totalizer. A falling edge (active to inactive) stops the totalizer.



Count range

---

**Count range**

Preset count

Predetermined count

Intermediate count

Reset source

OK

Set the 'Preset count' value – the value the totalizer counts from and the value applied when the totalizer is reset.

Set the 'Predetermined count' value – the value at which the totalizer stops or wraps.

**Note.** A counter configured to count up must have a 'Preset count' value lower than the 'Predetermined count' value. A counter configured to count down must have a 'Preset count' value greater than the 'Predetermined count' value.

Set the required number of decimal places on the higher of the 'Preset count' value or 'Predetermined count' value.

Set the 'Intermediate count' value – the value at which a digital source is activated. This can be used as an alarm threshold to indicate when the 'Predetermined count' value is about to be reached.

Select a 'Reset source' signal (see Appendix A, page 104) – an edge-triggered signal to reset the totalizer on a rising edge.

Log update

Select the frequency with which totalizer values are added to the Totalizer log.

Select a 'Log update source' signal (see Appendix A, page 104) – an edge-triggered signal to trigger the addition of the current totalizer values to the Totalizer log on a rising edge.

**Log update**

Log update time

Log update source

OK

Log update time	Log updated every...
5 minutes	0, 5, 10, 15... etc. minutes past the hour
10 minutes	0, 10, 20, 30,...etc. minutes past the hour
15 minutes	0, 15, 30, 45 minutes past the hour
20 minutes	0, 20, 40 minutes past the hour
30 minutes	0, 30 minutes past the hour
60 minutes	On the hour
2 hours	Midnight, 2am, 4am, etc.
3 hours	Midnight, 3am, 6am, etc.
4 hours	Midnight, 4am, 8am, etc.
8 hours	Midnight, 8am, 4pm, etc.
12 hours	Midnight, 12am
24 hours	Midnight

Count rate/Cut off  

Analog Input Sources only – see Section 4.6.1, page 72.

**Count rate/Cut off**

Count rate  

Cut off  

**OK**

Set the required totalizer count rate and cut off value.

The count rate is determined by the maximum number of engineering units (or pulses) per second and the smallest totalizer increment:

$$\frac{\text{engineering full scale value (rate)}}{\text{engineering units (in seconds)}}$$

**Example** – to totalize a flow with a maximum rate of 2500 liters/minute (= 2.5m<sup>3</sup>/minute) to the nearest 0.1m<sup>3</sup>, the calculation is as follows:

$$\frac{150\text{m}^3/\text{hour}}{3600 \text{ seconds}} = 0.04167 \text{ pulses/second}$$

The resulting value must be within the range 0.00001 to 99.99999. The totalizer increment is determined by the number of decimal places in the 'Predetermined count' value – see page 85.

The totalizer cut off value is the lowest input value (in engineering units) at which the totalizer is to stop counting.

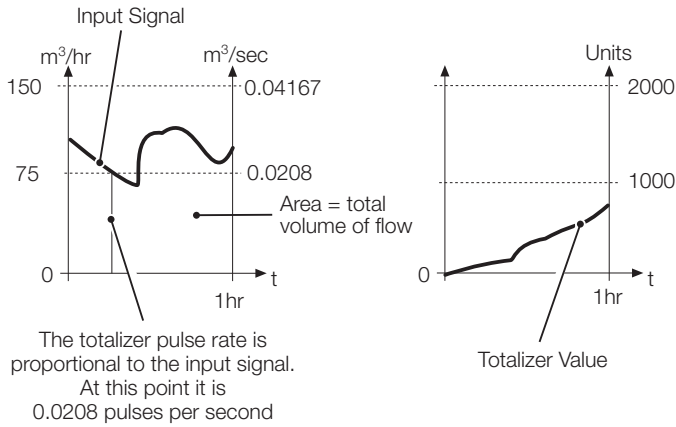

OR

Count rate  

Digital Input Sources only – see Section 4.6.1, page 72

Set the required totalizer count rate.

A digital totalizer pulse can be scaled to represent a value of between 0.00001 and 1000.00000. The totalizer is then incremented by this amount each time there is an on/off transition.

**Example** – a count of 5 digital pulses with 'Count rate' set to 100 increments the totalizer from 0 to 500 in 100 unit steps.

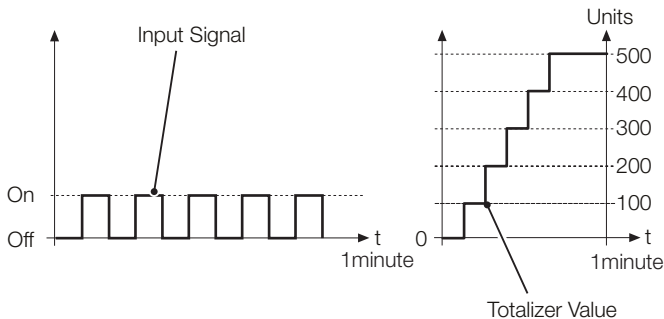

## 4.7 Functions

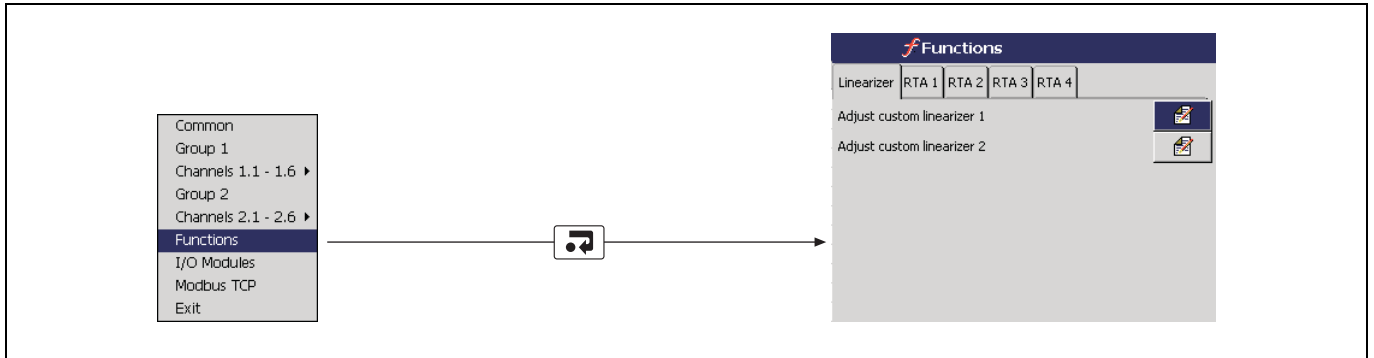
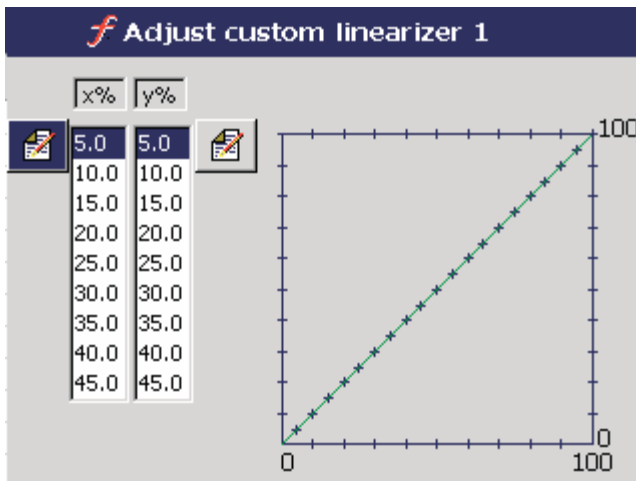
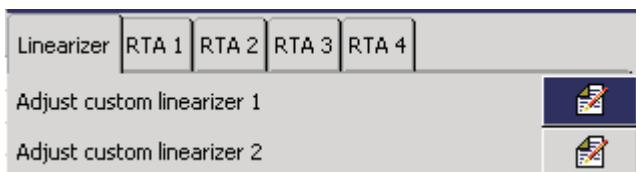

Fig. 4.16 Functions Configuration

### 4.7.1 Custom Linearizers



Use the ▲ and ▼ keys to highlight the linearizer to be adjusted.

Press the key to open the 'Adjust custom linearizer' screen.

Use the , , and keys to highlight the point to be modified.

Press the key to open the digipad to change the position of that point.

Press the key to return to the Functions screen.

Each linearizer has 20 breakpoints. Both X and Y values are set as percentages.

Custom linearizers can be applied to any analog input by selecting them as the linearizer type for that input – see Section 4.6.2, page 74.

**Note.**

X is input to the linearizer expressed as a percentage of the electrical range.

Y is output expressed as a percentage of the engineering range.

### 4.7.2 Real-time Alarms

Linearizer RTA 1 RTA 2 RTA 3 RTA 4

Alarm tag  

Enter the tag to be used in the Alarm Event log – see Section 2.7, page 23.

Daily enables  

Set the day(s) on which the alarm is activated.

**Daily enables**

Sunday  
 Monday  
 Tuesday  
 Wednesday  
 Thursday  
 Friday  
 Saturday

1st of the month enable  

Set to 'On' to activate the real-time alarm on the first day of each month.

1st of the month enable  

Set the time at which the alarm becomes active.

**On time**

Every hour  

Hours  

Minutes  

If 'Every hour' is set to 'On', the 'Hours' setting cannot be adjusted and the alarm is activated at the same time every hour (determined by the 'Minutes' setting) or on the hour (if 'Minutes' is set to 'Off').

Duration  

Set the duration for the alarm to remain active.

Log enable  

Set to 'On' to add an entry to the Alarm event log each time the real-time alarm becomes active.

## 4.8 I/O Module Configuration

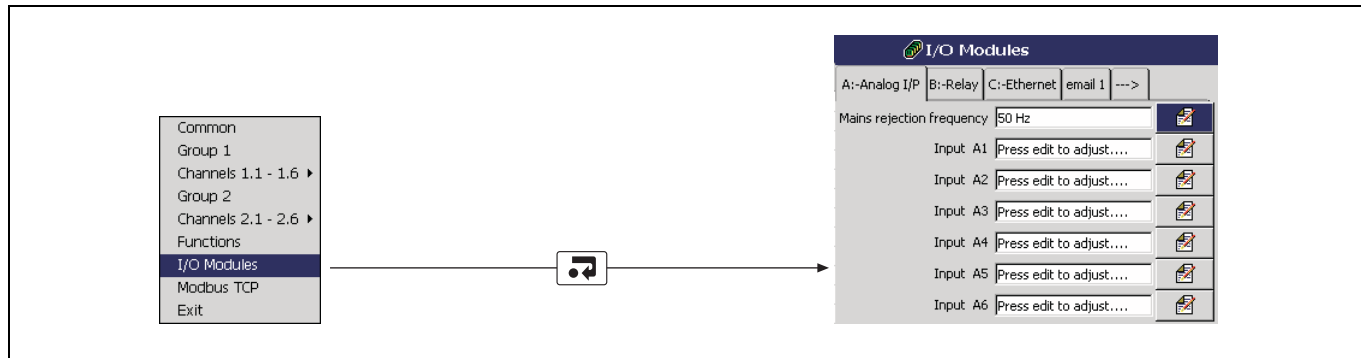
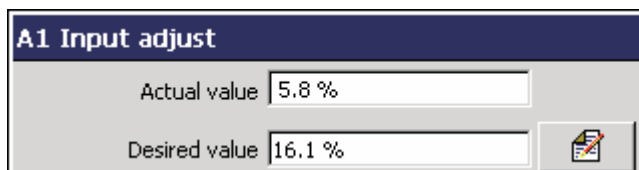
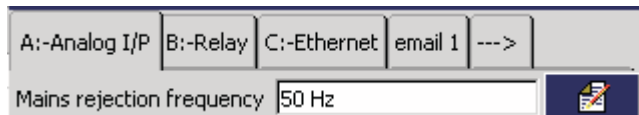

Fig. 4.17 I/O Module Configuration

**Note.** The instrument detects the type of module fitted in each position automatically.

### 4.8.1 Analog Inputs



Set the mains rejection frequency used to electrical noise induced on the signal lines by power supply cables.

#### Input Adjustment

Manually fine-tune inputs to remove process offset errors or system scale errors.

**Note.**

- Input adjustment frames appear only if recording is enabled during configuration, i.e. the 'Disable recording in configuration' check box is **not** ticked on entry to the Configuration level – see Fig. 4.1, page 46.
- Changes to the Analog Input Type (see Section 4.6.2, page 74) must be saved to the current configuration before commencing input adjustment.

#### Actual value / Desired value

1. Adjust the process or simulated input signal to a known value below 50% of the engineering range.
2. If 'Actual value' (in engineering units) is different from expected, set 'Desired value' to the correct value ('Offset adjust' and 'Span adjust' values are calculated automatically).
3. Repeat steps 1 and 2 for a value above 50% of the engineering range.
4. Repeat steps 1 to 3 for each input.

#### Reset adjustment

Select to reset 'Offset adjust' and 'Span adjust' (see next page) to zero and to 1 respectively.

Offset adjust  

Span adjust  

*Offset adjust / Span adjust*

Manually fine-tune the offset adjust and span adjust values to remove process errors. These are calculated values applied to the raw input signal.

**Note.** If simulating thermocouple inputs, connect the millivolt source using appropriate compensating cable – see Section 5.4.2, page 100. For 2-lead resistance thermometers, either connect the resistance box at the sensor end of the leads or add the lead resistance to the calibration values.

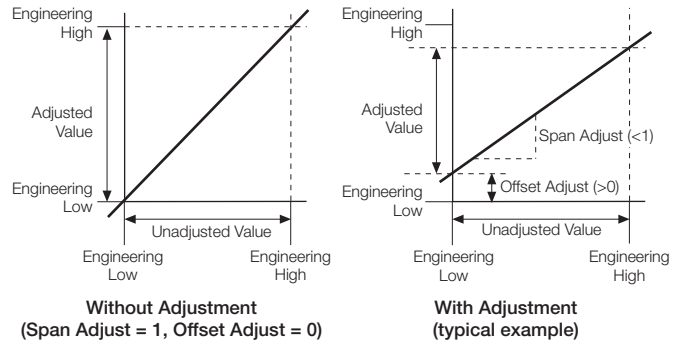



4.8.2 Relay Modules

A:-Analog I/P B:-Relay C:-Ethernet email 1 --->

Relay B1  

Relay B2  

Relay B3  

Relay B4  

Relay B5  

Relay B6  

Select the relay source (a digital source) to be used to energize/de-energize the relay.

**Note.** If the relay is used to provide a totalizer count pulse, the maximum pulse frequency is 5Hz. Consideration must also be given to the mechanical life of the relay.

Select the relay source polarity.

**Note.** When polarity is set to 'Positive', the relay is energized when the digital source is active (On).

4.8.3 Ethernet Modules

Refer to the *Ethernet Communications Option User Guide Supplement (IM/SMENET)* for information on how to install, configure and use the instrument on an Ethernet network and for information on configuring and using the e-mail facility.

A:-Analog I/P B:-Relay C:-Ethernet email 1 --->

IP-address  

#### 4.8.4 RS485 (Modbus™) Communications

Refer to Appendix B, page 106 for further information on using the optional Modbus link.

A:-Analog I/P B:-Relay C:-Modbus D:-Hybrid

Protocol

Select the Modbus protocol required.

Modbus – instrument acts as a Modbus Slave

Modbus Master – instrument acts as a Modbus Master

Type

Set according to the number of transmission wires connected to the instrument: 4-wire, 2-wire.

Baud rate

Set to the Baud rate used by the host system: 1200, 2400, 4800, 9600, 19200, 38400, 115200.

Parity

Set to the Parity used by the host system: None, Odd, Even.

Address

**Note.** Displayed only if 'Protocol' is set to 'Modbus'.

Set a unique Modbus Address that allows the host system to identify the instrument on a Modbus link.

**Note.** Maximum 31 slaves per loop.

Poll Rate (ms)

**Note.** Displayed only if 'Protocol' is set to 'Modbus Master'.

Set the poll rate in milliseconds – min. 0, max. 3600000.

Poll fail limit

**Note.** Displayed only if 'Protocol' is set to 'Modbus Master'.

Set the number of successive polls permitted to fail before the data is marked as a failed input – min. 0, max. 4.

Response Timeout (ms)

**Note.** Displayed only if 'Protocol' is set to 'Modbus Master'.

Set the timeout time in milliseconds for a single poll – min. 0, max. 60000.

**Note.** If any RTU devices are polled, set a response time that is long enough to allow for the normal turn around time from these devices. The configuration allows for only one setting for all devices connected to the network.

### 4.8.5 Comms Analog Input

**Note.** This tab is displayed only if 'Protocol' is set to 'Modbus Master' – see Section 4.8.4, page 91.

Select the comms analog input to hold the data from the nominated slave device.

Enter the RTU address assigned to the remote unit (1 to 247).

**Note.** Displayed only if 'RTU Address' is **not** set to 'None'.

Enter the register number to be read in the slave device.

**Note.** Displayed only if 'RTU Address' is **not** set to 'None'.

Select the register type, 'Holding Register' or 'Input Register'.

**Note.** Displayed only if 'RTU Address' is **not** set to 'None'.

Select the format of the data to be read from the slave device:

- Sint16 – signed, 16 bit integer
- Sint32 – signed, 32 bit integer, transmitted in high/low order
- rev. Sint32 – signed, 32 bit integer, transmitted in low/high order
- IEEE – 32 bit floating point number, transmitted in high/low order
- Rev. IEEE – 32 bit floating point number, transmitted in low/high order
- Sint16 X 10 – signed, 16 bit integer, multiplied by a factor of 10
- Sint16 X 100 – signed, 16 bit integer, multiplied by a factor of 100
- Sint16 X 1000 – signed, 16 bit integer, multiplied by a factor of 1000

#### 4.8.6 Comms Digital Input

**Note.** This tab is displayed only if 'Protocol' is set to 'Modbus Master' – see Section 4.8.4, page 91.

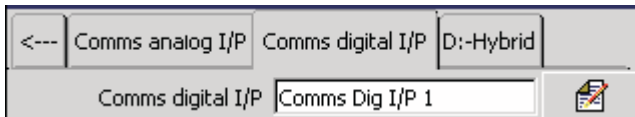

The screenshot shows a software interface with three tabs: '<---', 'Comms analog I/P', and 'Comms digital I/P'. The 'Comms digital I/P' tab is active, and a sub-tab 'D:-Hybrid' is also visible. Below the tabs, there is a label 'Comms digital I/P' and a text input field containing 'Comms Dig I/P 1'. A small icon of a document with a pencil is to the right of the input field.

Select the comms digital input to hold the data from the nominated slave device.



The screenshot shows a configuration field with the label 'RTU Address' and a text input box containing the number '1'. A small icon of a document with a pencil is to the right of the input box.

Enter the RTU address assigned to the remote unit (1 to 247).



The screenshot shows a configuration field with the label 'Register Number' and a text input box containing the number '0'. A small icon of a document with a pencil is to the right of the input box.

**Note.** Displayed only if 'RTU Address' is **not** set to 'None'.

Enter the register number to be read or written to in the slave device.

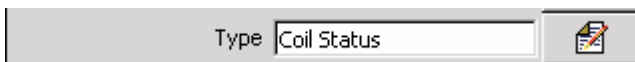

The screenshot shows a configuration field with the label 'Type' and a dropdown menu. The dropdown menu is open, and 'Coil Status' is selected. A small icon of a document with a pencil is to the right of the dropdown menu.

**Note.** Displayed only if 'RTU Address' is **not** set to 'None'.

Select the register type, 'Input Status' or 'Coil Status'.

### 4.8.7 Hybrid Modules

<--- email 2 D:-Hybrid

Digital o/p D1 + D2 None, None

**Digital o/p D1+D2**

D1 Source None

D1 Polarity Positive

D2 Source None

D2 Polarity Positive

OK

Digital o/p D3 + D4 None, None

Digital o/p D5 + D6 None, None

Select a digital output source.

**Note.**

- A digital output source is the internal digital source used to activate/de-activate a digital output.
- If a digital output is used to provide a totalizer count pulse, the maximum pulse frequency is 5Hz.

Select the digital output source polarity.

**Note.** When the polarity is set to 'Positive', the digital output is energized when the digital source is active (On).

The six digital inputs from any hybrid module produce six independent digital states that can be used as digital sources for recording channels, relay outputs, alarm acknowledgement etc., e.g.:

Digital I/P H1, Digital I/P H2

Additionally, digital inputs from a hybrid module in position H (see Fig. 5.5) can be used to produce up to 32 Binary Encoded (BCD) digital states, e.g.:

BCD digital I/P H0 to BCD digital I/P H31

BCD digital inputs can be used as digital sources in the same way as standard digital inputs.

Inputs H1, H2, H3, H4 and H5 have 'weightings' of 1, 2, 4, 8, and 16 respectively. A rising edge on input H6 is used as the update trigger.

Following an inactive to active transition on input H6, inputs H1 to H5 are evaluated, the weighted values of any active inputs are added together and the BCD digital input corresponding to the total is activated. All other BCD digital inputs are deactivated.

**Example.**

If digital inputs H1 (weighting = 1), H2 (weighting = 2) and H4 (weighting = 8) are active when digital input H6 (update trigger) is activated, BCD digital input H11 (1 + 2 + 8) is activated. BCD digital inputs H0 to H10 and BCD digital inputs H12 to H31 are deactivated.

If digital inputs H1 to H5 are all inactive when digital input H6 (update trigger) is activated then BCD digital input H0 is activated. BCD digital inputs H1 to H31 are deactivated.

Analog o/p D1 Source  

Select the analog output source.

**Note.** The analog output source can be any internal or external analog signal.

Analog o/p D1 range  

Set the required analog output engineering and electrical ranges.

**Note.** The 'Engineering low' and 'Engineering high' settings are the engineering values corresponding to the 'Electrical low' and 'Electrical high' values below.

**Analog output D1 range**

Engineering low  

Engineering high  

Electrical low  

Electrical high  

The 'Electrical low' and 'Electrical high' values are the minimum and maximum values of the current output, in Electrical units – range 0 to 23mA.

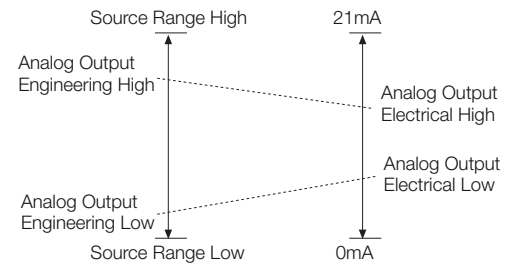

Analog o/p D1 range  

Analog o/p D2 Source  

#### 4.9 Modbus TCP

**Note.** Modbus TCP is available only if the optional ethernet module is fitted.

Modbus TCP enables Modbus devices to communicate via an ethernet network transferring Modbus messages via TCP/IP. Communication with standard, serially connected, Modbus RTU devices is also possible through a Modbus TCP Gateway.

Refer to the *Ethernet Communications Option User Guide Supplement (IM/SMENET)* for information on how to install, configure and use the instrument on an Ethernet network and for information on configuring and using the Modbus TCP facility.

Refer to Appendix B, page 106 for further information on using the Modbus link.

Modbus TCP

Implementation  

## 5 Installation

### EC Directive 89/336/EEC

In order to meet the requirements of EC Directive 89/336/EEC for EMC regulations, this product must not be used in a non-industrial environment.

### End of Life Disposal

- The instrument contains a small lithium battery which should be removed and disposed of responsibly in accordance with local environmental regulations.
- The remainder of the instrument does not contain any substance that will cause undue harm to the environment and must be disposed of in accordance with the Directive on Waste Electrical and Electronic Equipment (WEEE). It must not be disposed of in Municipal Waste Collection.

### Cleaning

Clean only the front panel, using warm water and a mild detergent.

### 5.1 Siting – Figs. 5.1 and 5.2

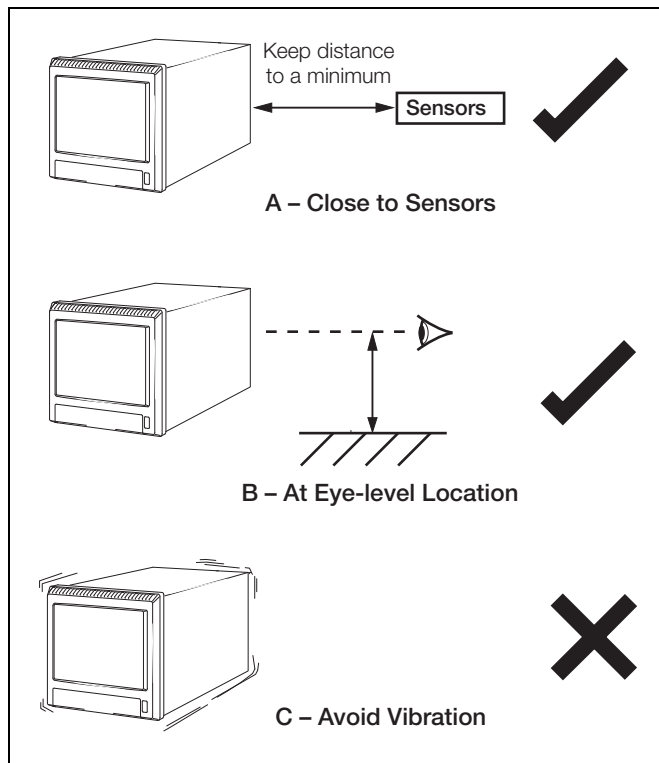

Fig. 5.1 General Requirements

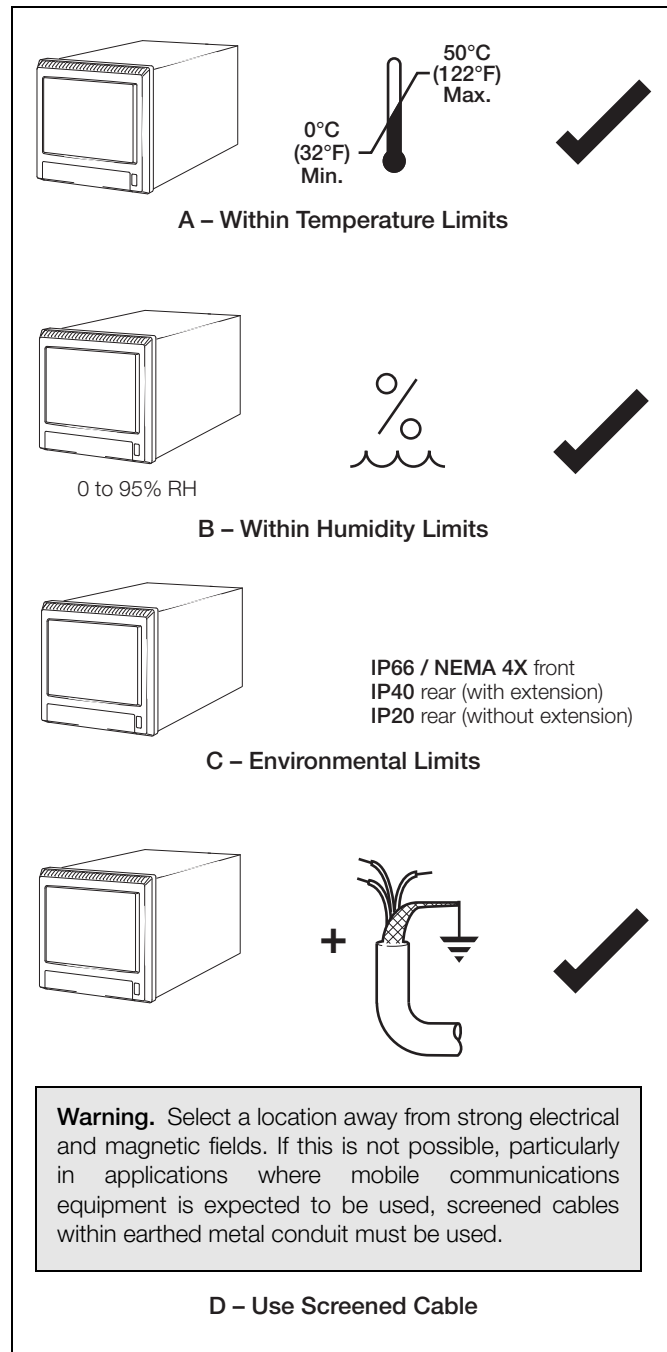

Fig. 5.2 Environmental Limits

5.2 Mounting – Figs. 5.3 and 5.4

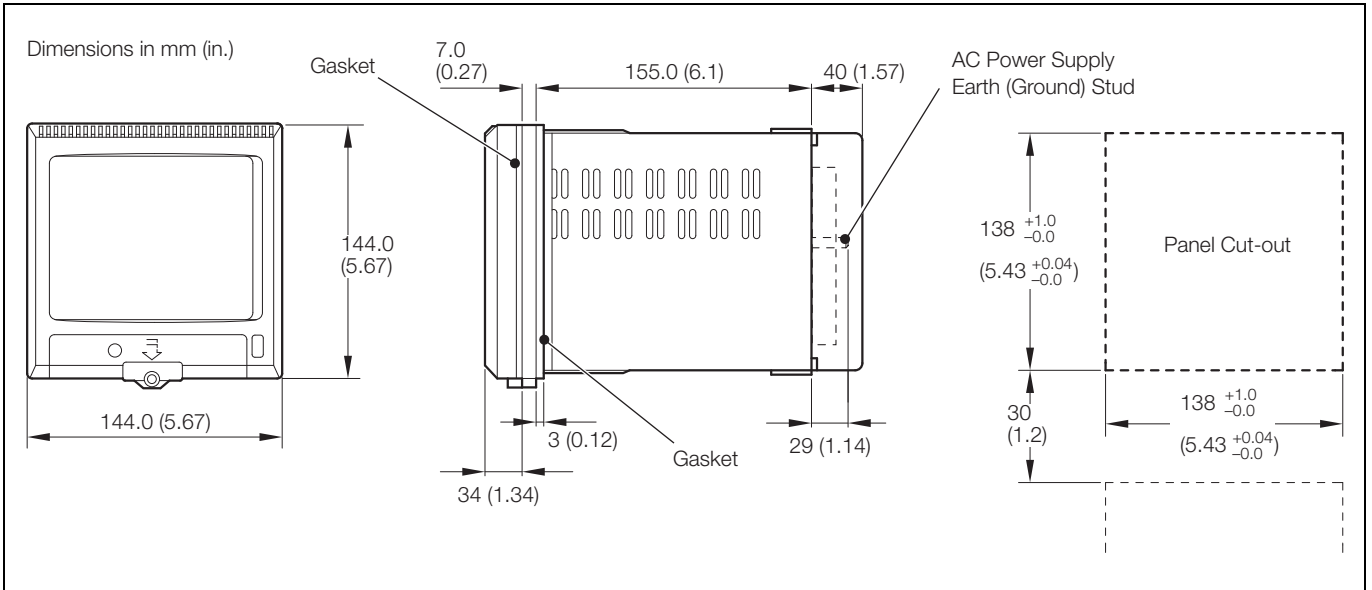

Fig. 5.3 Mounting Dimensions

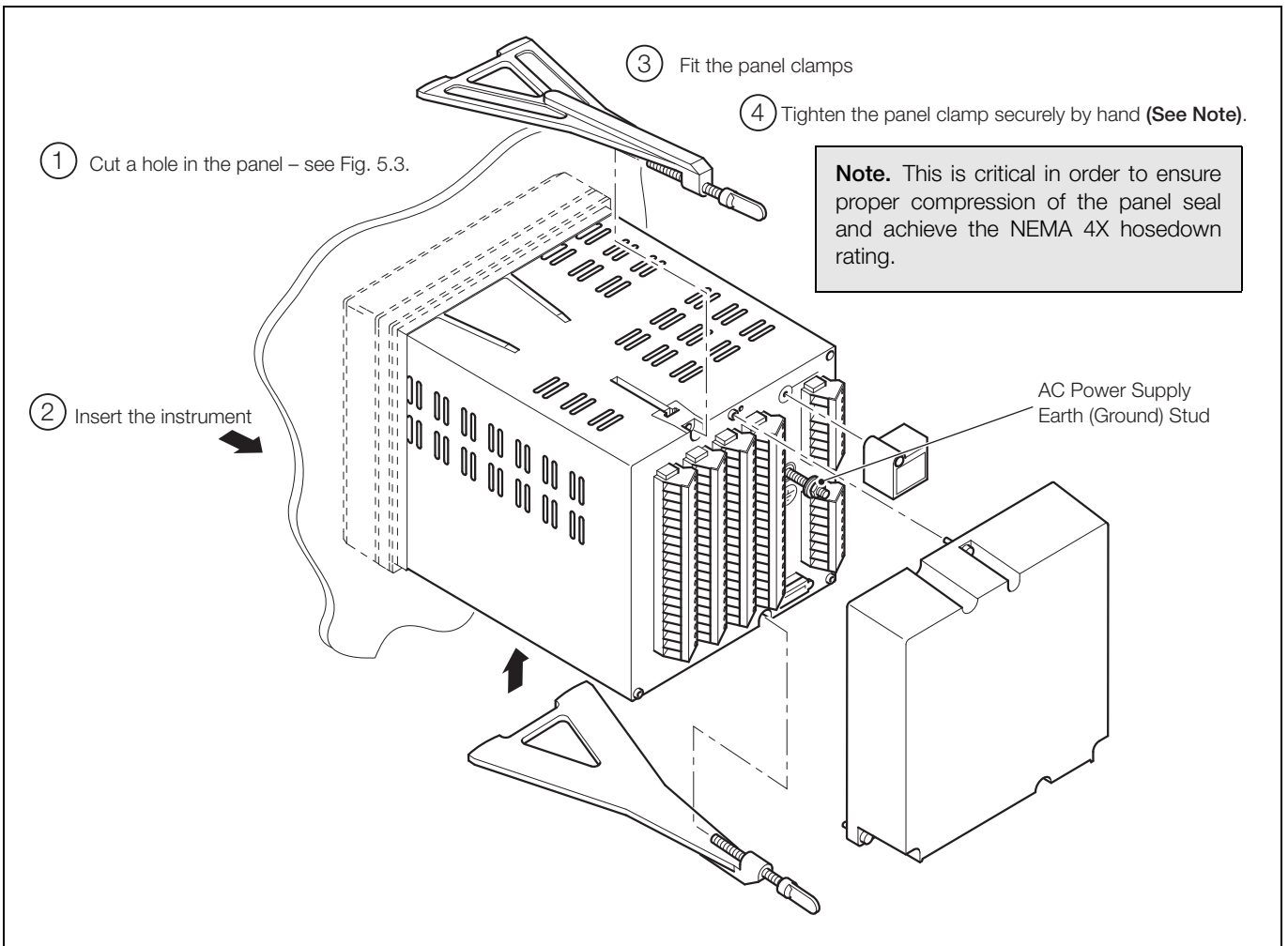



Fig. 5.4 Fitting the Instrument into the Panel

### 5.3 Electrical Connections – Fig. 5.5

#### Warning.

- The instrument is not fitted with a switch therefore a disconnecting device such as a switch or circuit breaker conforming to local safety standards must be fitted to the final installation. It must be fitted in close proximity to the instrument within easy reach of the operator and must be marked clearly as the disconnection device for the instrument.
- The AC power supply earth (ground) cable must be connected to the earth (ground) stud .
- Remove all power from supply, relay and any powered control circuits and high common mode voltages before accessing or making any connections.
- Use cable appropriate for the load currents. The terminals accept cables up to 14AWG (2.5mm<sup>2</sup>).
- The instrument conforms to Mains Power Input Insulation Category III. All other inputs and outputs conform to Category II.
- All connections to secondary circuits must have basic insulation.
- After installation, there must be no access to live parts, e.g. terminals.
- Terminals for external circuits are for use only with equipment with no accessible live parts.
- If the instrument is used in a manner not specified by the Company, the protection provided by the equipment may be impaired.
- All equipment connected to the instrument's terminals must comply with local safety standards (IEC 60950, EN601010-1).

#### Note.

- Always route signal leads and power cables separately, preferably in earthed (grounded) metal conduit.
- It is strongly recommended that screened cable is used for signal inputs and relay connections. Connect the screen to the earth (ground stud) – see Fig. 5.5, page 99.
- Replacement of the internal battery (types Duracell DL2450 or Renata CR2450N 3V lithium cell) must be carried out by an approved technician only.

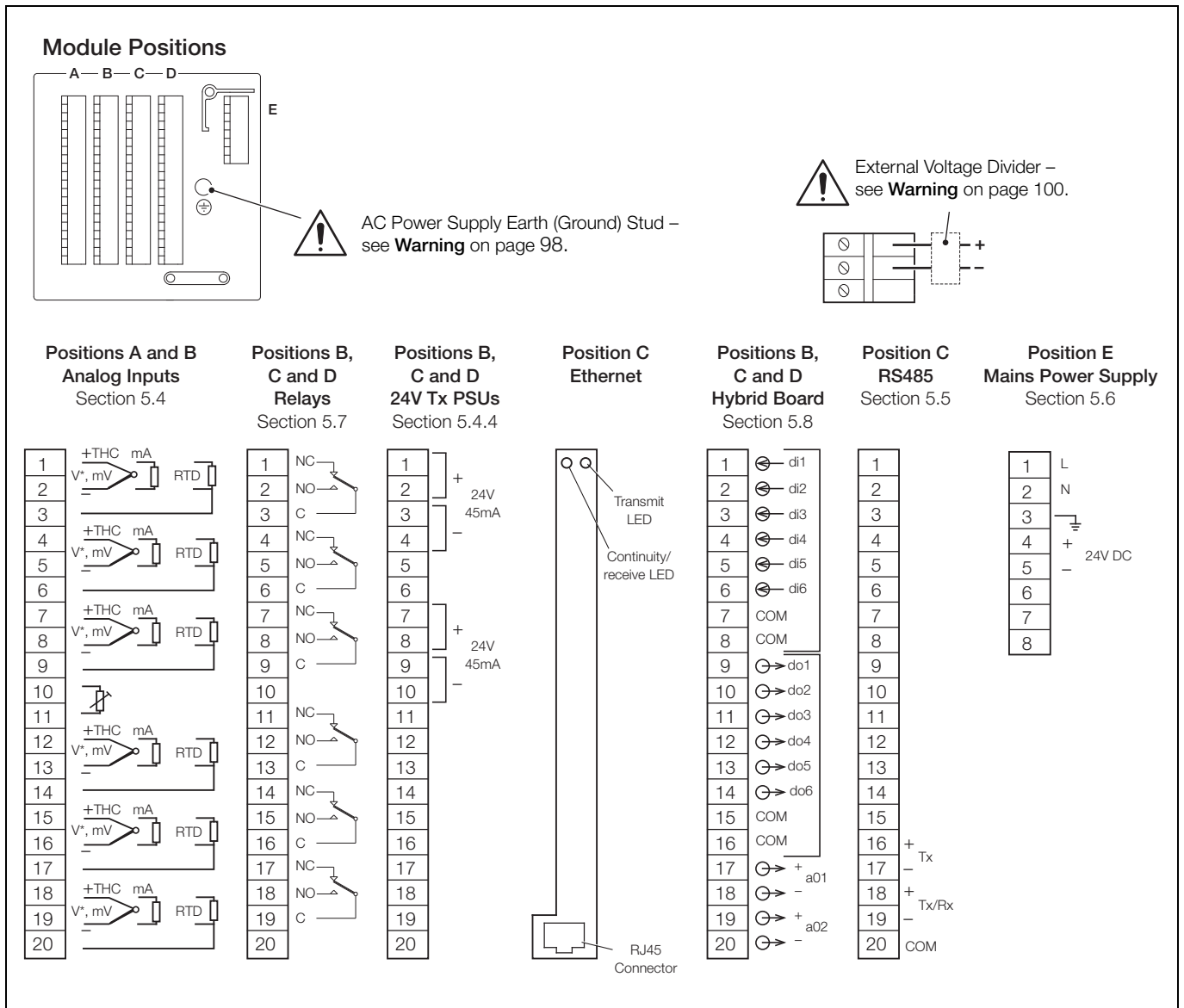

Fig. 5.5 Electrical Connections

**Note.** Terminal screws must be tightened to a torque of 2.5 lbf.in (0.28 Nm).

## 5.4 Analog Inputs

### 5.4.1 Current and Voltage – Fig. 5.6

#### Warning.

- When input 'Type' is set to 'Volts' (see Section 4.6.2, page 74), input signals with voltages greater than 2V (standard inputs) or 1V (high specification inputs) **must** be connected through an external voltage divider (part no. GR2000/0375).
- Input signals with voltages up to 2V (2000mV – standard inputs) or 1V (1000mV – high specification inputs) may be measured without the need for the voltage divider by setting 'Type' to 'millivolts' – see Section 4.6.2, page 74.
- An external 10Ω shunt resistor is required for current ranges.
- To avoid damage to multi-channel instruments, high common mode voltages up to 500V r.m.s. max. must be present on all channels, or not at all.
- For the standard input card the maximum channel-to-channel voltage (between any two channels) must not exceed 35V or permanent damage to the instrument's input circuitry may occur. For applications requiring higher levels of isolation refer to the high specification card.

### 5.4.2 Thermocouple – Fig. 5.6

Use the correct compensating cable between the thermocouple and the terminals – see Table 5.1 on page 102.

Automatic cold junction compensation (ACJC) is incorporated but an independent cold (reference) junction may be used.

### 5.4.3 Resistance Thermometer (RTD) – Fig. 5.6

On applications requiring long leads it is preferable to use a 3-lead resistance thermometer.

If 2-lead resistance thermometers are used, each input must be calibrated to take account of the lead resistance.

### 5.4.4 Transmitter Power Supply – Fig. 5.7

**Note.** Two 24V power supplies are provided on the transmitter power supply module boards, each of which is capable of driving two 2-wire transmitters.

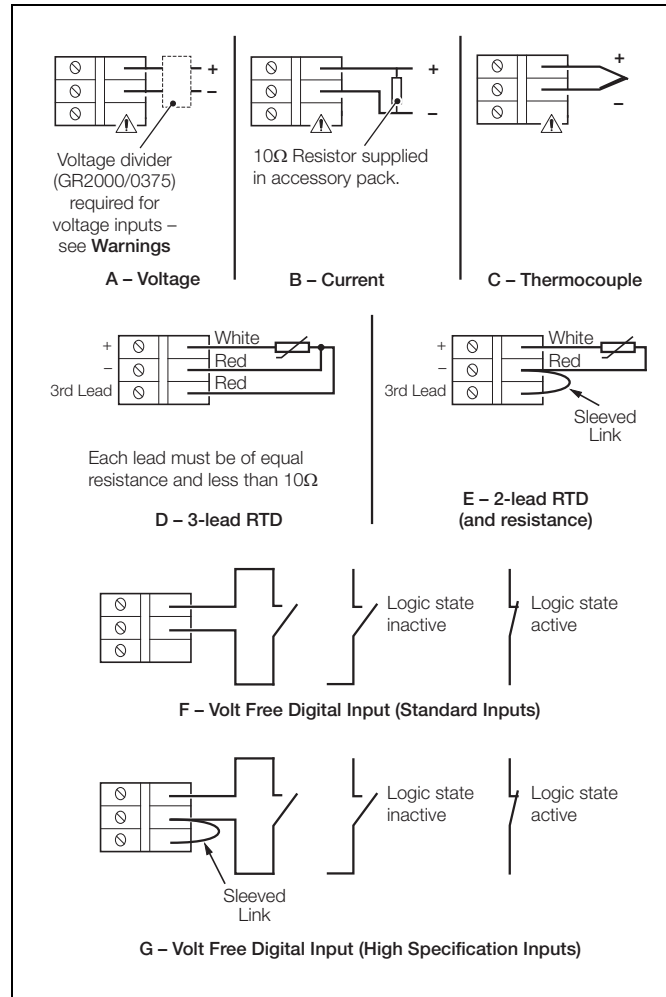

Fig. 5.6 Analog Input Connections

**Warning.** Under no circumstances must the spare input terminal be linked to the negative.

**Note.** Refer also to Fig. 5.5 for terminal numbers.

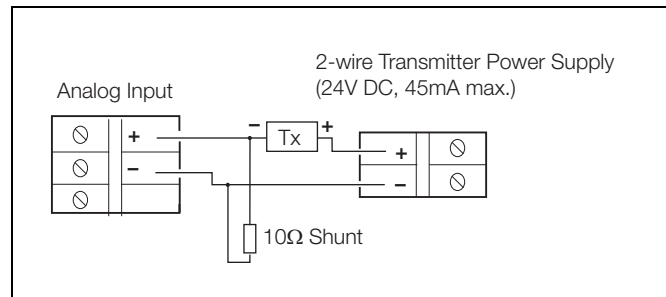

Fig. 5.7 Transmitter Power Supply

### 5.5 RS422/485 Serial Communications

The optional serial interface module has been designed to operate using the Modbus Remote Terminal Unit (RTU) Master/Slave protocol.

An appropriate RS422/485 communications driver must be fitted to the host (Master) computer. It is strongly recommended that the interface has galvanic isolation to protect the computer from lightning damage and increase the signal immunity to noise pick-up.

The maximum serial data transmission line length for both RS422 and RS485 systems is 1200m. The types of cable that can be used are determined by the total line length:

- Up to 6m** – standard screened or twisted pair cable.
- Up to 300m** – twin twisted pair with overall foil screen and an integral drain wire.
- Up to 1.2km** – twin twisted pair with separate foil screens and integral drain wires.

**Note.**

- To prevent false triggering of slaves when the master (host computer) is inactive, pull-up and pull-down resistors must be fitted to the RS422/485 interface in the host computer.
- Resistors are normally connected to the interface by means of hard-wired links or switches – refer to the manufacturer's instructions.
- For long transmission lines, a 120Ω termination resistor must be fitted to the last slave in the chain.
  - Connections on links with multiple slaves must be made in parallel.
  - When connecting cable screens, ensure that no 'ground loops' are introduced.

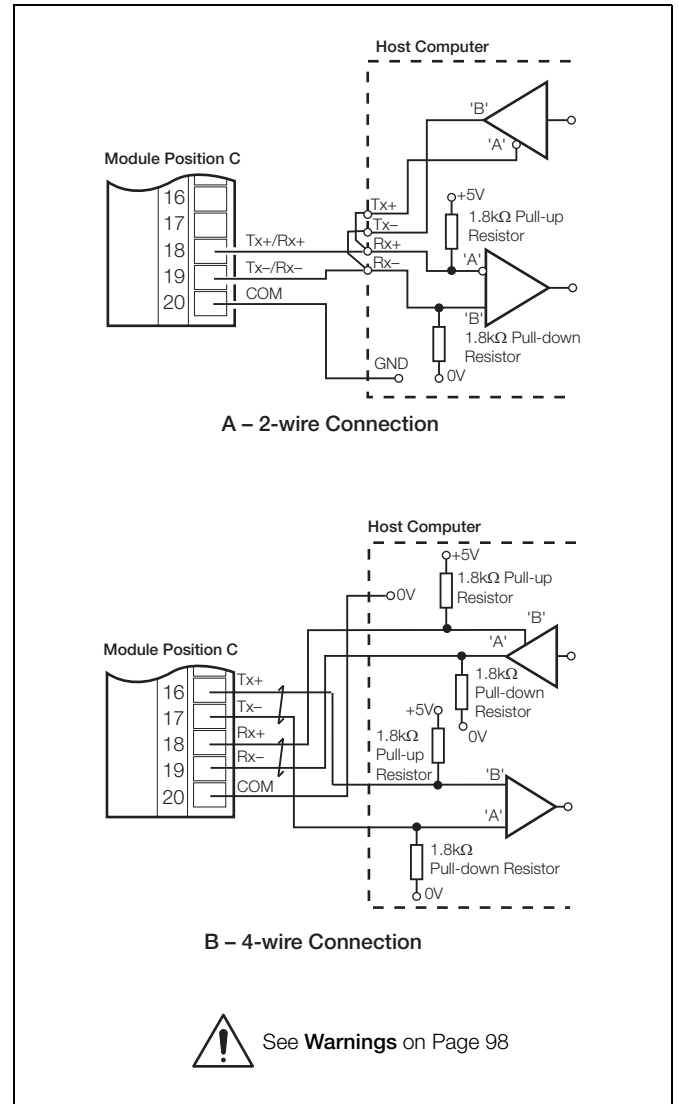

Fig. 5.8 RS422/485 Serial Communications

Type of Thermocouple	Compensating Cable											
	BS1843			ANSI MC 96.1			DIN 43714			BS4937 Part No.30		
	+	-	Case	+	-	Case	+	-	Case	+	-	Case
Ni-Cr/Ni-Al (K)	Brown	Blue	Red	Yellow	Red	Yellow	Red	Green	Green	Green	White	Green *
Ni-Cr/Cu-Ni (E)										Violet	White	Violet *
Nicrisil/Nisil (N)	Orange	Blue	Orange	Orange	Red	Orange				Pink	White	Pink *
Pt/Pt-Rh (R and S)	White	Blue	Green	Black	Red	Green	Red	White	White	Orange	White	Orange *
Pt-Rh/Pt-Rh (B)										Grey	White	Grey *
Cu/Cu-Ni (T)	White	Blue	Blue	Blue	Red	Blue	Red	Brown	Brown	Brown	White	Brown *
Fe/Con (J)	Yellow	Blue	Black	White	Red	Black	Red	Blue	Blue	Black	White	Black *
* Case Blue for intrinsically safe circuits												
Fe/Con (DIN 43710)							<b>DIN 43710</b>					
							Blue/Red	Blue	Blue			

Table 5.1 Thermocouple Compensating Cable

5.6 Mains Power Connections – Figs. 5.9 and 5.10

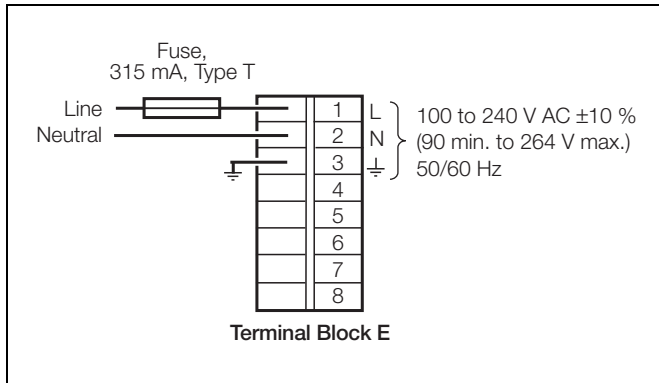

Fig. 5.9 AC Power Supply

**Warning.** Use fuse rating – 315mA (max.) type T.

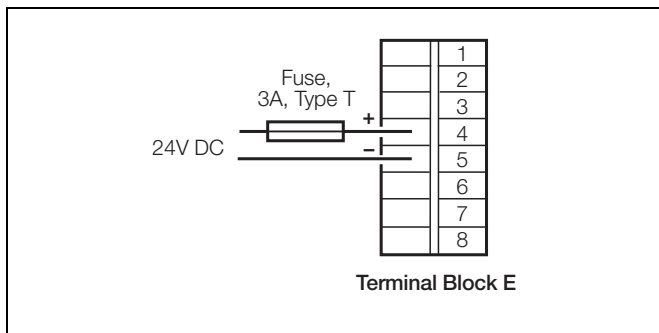

Fig. 5.10 DC Power Supply

**Warning.** Use fuse rating – 3A (max.) type T.

5.7 Relay Output Board Connections – Fig. 5.11

**Note.**

- The maximum total combined current flowing through the relays is 36A. The maximum individual relay current is 5A.
- The polarity is selected during I/O module configuration – see Section 4.8.2, page 90.

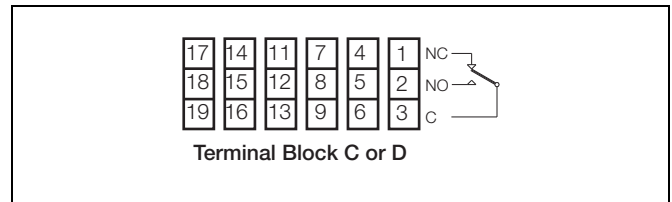

Fig. 5.11 Relay Connections

**Note.** Relay contacts are fitted with arc suppression components as standard.

## 5.8 Hybrid I/O Module Connections

### 5.8.1 Digital Output Connections – Fig. 5.12

Six digital outputs are provided on the Hybrid option board.

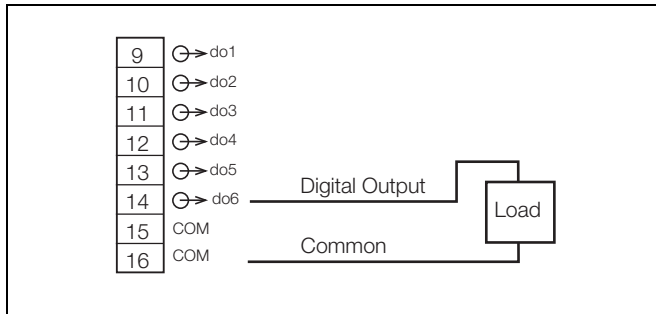

Fig. 5.12 Digital Output Connections

**Note.** Voltage level: 5V.  
Load: 450Ω min. 15kΩ max.

### 5.8.2 Digital Input Connections – Fig. 5.13

Six digital inputs are provided on Hybrid option boards.

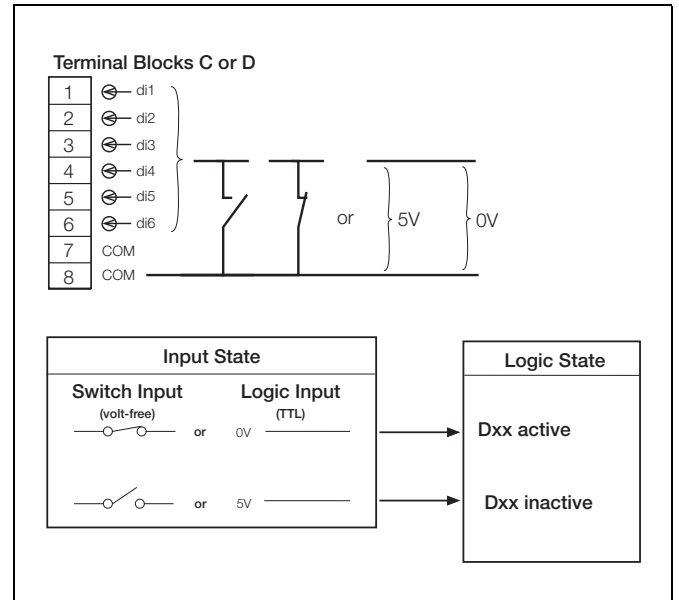

Fig. 5.13 Digital Input Connections

### 5.8.3 Analog Output Connections – Fig. 5.14

Two analog outputs are provided on the Hybrid option board.

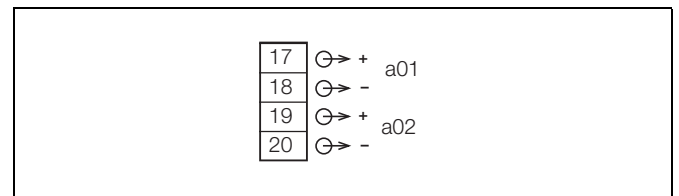

Fig. 5.14 Analog Output Connections

## Appendix A – Signal Sources

Source Name	Description
<b>Analog Sources</b>	
Analog I/P A1 to Analog I/P B6	<b>Analog input values</b> (from Analog input module). Available only if an analog input module is fitted in the relevant position.
Comms AIN 1 to 24	<b>Analog input values.</b> Received via the Modbus/Modbus TCP serial communications link – see Appendix B, page 106.
Stats 1.1 max to Stats 2.6 max	<b>Maximum Statistics Input Value.</b> Value since the totalizer on a given channel last wrapped or reset. Available only on analog channels and if the relevant totalizer is enabled in the Configuration level.
Stats 1.1 min to Stats 2.6 min	<b>Minimum Statistics Input Value.</b> Value since the totalizer on a given channel last wrapped or reset. Available only on analog channels and only if the relevant totalizer is enabled in the Configuration level.
Stats 1.1 avg to Stats 2.6 avg	<b>Average Statistics Input Value.</b> Value since the totalizer on a given channel last wrapped or reset. Available only on analog channels and only if the relevant totalizer is enabled in the Configuration level.
<b>Error States</b>	
AIN A1 fail to AIN B6 fail	<b>Analog Input Failure.</b> Active when the signal detected at the analog input is outside the 'Fault Detect Level' specified in Section 4.6.2.
Comms AIN 1 fail to Comms AIN 24 fail	
Stats 1.1 fail to Stats 2.6 fail	<b>Totalizer Input Value Failure.</b> Activated when the totalizer fails, cleared when the totalizer wraps or is reset. Available only for analog channels if the relevant totalizer is enabled in the Configuration level.
Archive media not present	Active when the removable archive media is not present.
Too many files on archive media	Active when there are approximately 300 files on the removable archive media.
Archive 100% full	Active when the removable archive media is 100% full.
Archive 80% full	Active when the removable archive media is 80% full.
Archive media present	Active when the removable archive media is present.
Archive on-line	Active when archiving is in progress.
<b>Digital Input States</b>	
Digital I/P A1 to Digital I/P D6	<b>Digital Input States.</b> From optional hybrid I/O boards fitted at module positions C or D or from analog input modules fitted at module positions A or B if input 'Type' is set to 'Volt free digital input' – see Section 4.6.2, page 74. Available only if the module is fitted.
BCD digital I/P D0 to BCD digital I/P D31	<b>BCD (Binary Coded Decimal) Digital Input States.</b> Digital states derived from digital inputs D1 to D6. Available only if optional hybrid I/O board is fitted in module position D.

Table A.1 Signal Sources

Source Name	Description
Comms Dig I/P 1 to Comms Dig I/P 24	<b>Digital Input States.</b> Digital signals received via Modbus/Modbus TCP serial link – see Appendix B, page 106.
Alarm state 1.1A to Alarm state 2.6B	<b>Alarm States.</b> Available only if the relevant alarm is enabled in the Configuration level.
Alarm ack 1.1A to Alarm ack 2.6B	<b>Alarm Acknowledge States.</b> Available only if the relevant alarm is enabled in the Configuration level. Acknowledged alarm = 0; Unacknowledged alarm = 1. Applicable to Process, Latch and Annunciator alarms only.
Alarm group 1 to Alarm group 12	<b>Alarm Groups.</b> Available only if any alarms are enabled in the configuration level. Active only if any of the alarms assigned to a group are active.
Any alarm	Available only if there is at least one alarm enabled in the configuration level. Active only if any of the enabled alarms are active.
New alarm	Available only as a source for e-mail triggers. Causes an e-mail to be generated if any alarm becomes active.
Real time alarm 1 to Real time alarm 4	<b>Real Time Alarm States.</b> Available only if the relevant alarm is enabled in the Configuration level.
Run state 1.1 to Run state 2.6	<b>Totalizer Run States.</b> Active while totalizer is running. Available only if the relevant totalizer is enabled in the Configuration level.
Wrap pulse 1.1 to Wrap pulse 2.6	<b>Totalizer Wrap Pulse.</b> Available only if the relevant totalizer is enabled in the Configuration level – see Section 4.6.5, page 84. If 'Wrap Enable' set to 'On': Active for 2 seconds when the predetermined count has been reached. If 'Wrap Enable' set to 'Off': Active when the predetermined count has been reached and remains active until the totalizer is reset.
1st stage o/p 1.1 to 1st stage o/p 2.6	<b>Totalizer First Stage Output (Intermediate Count).</b> Active for 1 second when the intermediate count has been reached – see Section 4.6.5, page 84. Available only if the relevant totalizer is enabled in the Configuration level.
Count pulse 1.1 to Count pulse 2.6	<b>Totalizer Count Pulse.</b> Active for 100ms each time the totalizer updates by one whole count, e.g. if two decimal places are set, a pulse is generated when the totalizer value increments from 0.99 to 1.00 or 1.99 to 2.00.

Table A.1 Signal Sources (Continued)

## Appendix B – Modbus Guide

### B.1 Introduction

A Modbus/RS485 serial communications link is available as an option.

The instrument can be configured to act as either a Remote Terminal Unit (RTU) slave when communicating with a master (host) system, or as a Modbus master device, enabling it to collect data from RTU slaves into its 24 Comms Analog and 24 Comms Digital Channels.

### B.2 Setting Up

To set up the instrument on a Modbus network:

1. Connect the instrument to a Modbus link – see Section 5.5, page 101.
2. Set the RS485 configuration parameters – see Section 4.8.4, page 91.
3. Add the instrument to the link configuration on the host system – refer to information supplied with the host system.

### B.3 Modbus Commands Supported

The following Modbus commands are supported:

- 01 **Read Coil Status** – reads the on/off status of 16 consecutive digital states, starting at a specified address. The instrument returns zeros for points which do not contain defined data
- 03 **Read Holding Registers** – reads 8 consecutive analog values, starting from a specified address. The instrument returns zeros for registers which do not contain defined data.
- 05 **Force Single Coil** – sets the value of a single coil (digital signal) at the specified address. The data value must be FF00<sub>Hex</sub> to set the signal ON and zero to turn it OFF. The instrument returns an exception response if the register is not currently writable.
- 06 **Preset Single Register** – sets the value of a single register (analog value) at the specified address. The instrument returns an exception response if the register is not currently writable. Limits defined in configuration are applied to the value before storage.
- 08 **Loopback Diagnostic Test** – used to test the integrity of Modbus transmissions. The instrument returns the message received.
- 15 **Force Multiple Coils** – the instrument carries out updates that are valid and returns an exception response if any of the coils are not currently writable.
- 16 **Preset Multiple Registers** – the instrument carries out updates that are valid and generates an exception response if any of the registers are not currently writable.

#### Note.

- Negative numbers are represented in '2's complement' format, e.g 1000 = 03E8 (Hex), -1000 = FC18 (Hex)
- The instrument cannot accept a new message until the current message has been processed and a reply sent to the master (maximum response time 50ms).
- The instrument monitors the elapsed time between receipt of characters from the host. If the elapsed time between two characters is 3.5 character times, the slave assumes the second character received is the start of a new message.

### B.4 Modbus Exception Responses

If the instrument detects one of the errors listed in Table A2.1 while receiving a message from the host system, it replies with a response message consisting of the instrument's Modbus address, the function code, the error code and error check fields.

Code	Name	Definition
01	Illegal Function	The message function received is not an allowable action
02	Illegal Data Address	The address reference in the data field is not an allowable address
03	Illegal Data Value	The value referenced in the data field is not allowable in the addressed slave
07	Negative Acknowledgment	Received message error
08	Memory Parity Error	Parity check indicates an error in one or more of the characters received

Table B.1 Modbus Exception Responses

### B.5 Operating Mode Modbus Coils

Tables A2.2 to A2.14 detail the contents of each Modbus coil. Each coil is assigned a register that can have one of two values: 0000 and 0001.

Analog Input	Modbus Coil (Read Only) 0 = Input OK 1 = Input failed	Analog Input	Modbus Coil (Read Only) 0 = Input OK 1 = Input failed
A1	0001	B1	0007
A2	0002	B2	0008
A3	0003	B3	0009
A4	0004	B4	0010
A5	0005	B5	0011
A6	0006	B6	0012
		Reserved	0013 to 0050

Table B.2 Analog Input Fail States

		Alarm Active/Inactive	Alarm Acknowledge
<b>Read Access</b>		0 = Alarm inactive 1 = Alarm active	0 = Acknowledged or inactive  1 = Active and un-acknowledged
<b>Write Access</b>		None	0 = No Effect 1 = Acknowledge
No.	Title	Modbus Coil	Modbus Coil
1	Alarm 1.1A	0051	0101
2	Alarm 1.1B	0052	0102
3	Alarm 1.2A	0053	0103
4	Alarm 1.2B	0054	0104
5	Alarm 1.3A	0055	0105
6	Alarm 1.3B	0056	0106
7	Alarm 1.4A	0057	0107
8	Alarm 1.4B	0058	0108
9	Alarm 1.5A	0059	0109
10	Alarm 1.5B	0060	0110
11	Alarm 1.6A	0061	0111
12	Alarm 1.6B	0062	0112
13	Alarm 2.1A	0063	0113
14	Alarm 2.1B	0064	0114
15	Alarm 2.2A	0065	0115
16	Alarm 2.2B	0066	0116
17	Alarm 2.3A	0067	0117
18	Alarm 2.3B	0068	0118
19	Alarm 2.4A	0069	0119
20	Alarm 2.4B	0070	0120
21	Alarm 2.5A	0071	0121
22	Alarm 2.5B	0072	0122
23	Alarm 2.6A	0073	0123
24	Alarm 2.6B	0074	0124
	Reserved	0075 to 0100	0125 to 0150

Table B.3 Alarm States

	Coil Number
<b>Title</b>	Read: Always returns '0' Write: 1 = Activate
Operator Message 1	0151
Operator Message 2	0152
Operator Message 3	0153
Operator Message 4	0154
Operator Message 5	0155
Operator Message 6	0156
Operator Message 7	0157
Operator Message 8	0158
Operator Message 9	0159
Operator Message 10	0160
Operator Message 11	0161
Operator Message 12	0162
Operator Message 13	0163
Operator Message 14	0164
Operator Message 15	0165
Operator Message 16	0166
Operator Message 17	0167
Operator Message 18	0168
Operator Message 19	0169
Operator Message 20	0170
Operator Message 21	0171
Operator Message 22	0172
Operator Message 23	0173
Operator Message 24	0174
Reserved	0175 to 0180

Table B.4 Operator Messages

Title	Coil Number	Read	Write
Assign to Group 1	0181	0 = Remote operator message not assigned to group	0 = Unassign remote operator message from group
Assign to Group 2	0182	1 = Remote operator message assigned to group	1 = Assign remote operator message to group
Activate Remote Operator Message	0183	Always reads as 0	0 = No effect 1 = Activate

Table B.5 Remote Operator Messages

Modbus Coil Numbers			
Read Only. 0 = Output or Input Inactive; 1 = Output or Input Active			
Channel	Digital Inputs	Digital Outputs	Relay Outputs
Not Used	0201 to 0212	0251 to 0262	0301 to 0312
C1	0213	0263	0313
C2	0214	0264	0314
C3	0215	0265	0315
C4	0216	0266	0316
C5	0217	0267	0317
C6	0218	0268	0318
D1	0219	0269	0319
D2	0220	0270	0320
D3	0221	0271	0321
D4	0222	0272	0322
D5	0223	0273	0323
D6	0224	0274	0324
Not Used	0225 to 0250	0275 to 0300	0325 to 0350

Table B.6 Digital I/O States

		Modbus Registers				
		Stop/Go	Reset	Wrap Pulse	1st Stage Pulse	Flowrate Failure
	<b>Read</b>	0 = Stopped 1 = Running	0 = >1s* 1 = <1s*	0 = Inactive 1 = Active	0 = Inactive 1 = Active	0 = OK 1 = Failed
	<b>Write</b>	0 = Stop 1 = Start	1 = Reset			
1	Totalizer 1.1	0351	0401	0451	0501	0551
2	Totalizer 1.2	0352	0402	0452	0502	0552
3	Totalizer 1.3	0353	0403	0453	0503	0553
4	Totalizer 1.4	0354	0404	0454	0504	0554
5	Totalizer 1.5	0355	0405	0455	0505	0555
6	Totalizer 1.6	0356	0406	0456	0506	0556
7	Totalizer 2.1	0357	0407	0457	0507	0557
8	Totalizer 2.2	0358	0408	0458	0508	0558
9	Totalizer 2.3	0359	0409	0459	0509	0559
10	Totalizer 2.4	0360	0410	0460	0510	0560
11	Totalizer 2.5	0361	0411	0461	0511	0561
12	Totalizer 2.6	0362	0412	0462	0512	0562
	Reserved	0363 to 0400	0413 to 0450	0463 to 0500		

\* Time since last reset

Table B.7 Totalizer Digital Signals

	Read Only. 0 = All alarms inactive 1 = At least 1 alarm active
Title	Coil Number
Any Alarm	0750

Table B.8 Any Alarm

	Read Only. 0 = Alarm group inactive 1 = Alarm group active
Title	Coil Number
Alarm Group 1	0751
Alarm Group 2	0752
Alarm Group 3	0753
Alarm Group 4	0754
Alarm Group 5	0755
Alarm Group 6	0756
Alarm Group 7	0757
Alarm Group 8	0758
Alarm Group 9	0759
Alarm Group 10	0760
Alarm Group 11	0761
Alarm Group 12	0762

Table B.9 Alarm Groups

Read Only: 0 = All alarms inactive  
1 = At least 1 alarm active

Title	Coil Number	Title	Coil Number	Title	Coil Number	Title	Coil Number
BCD digital I/P D0	0801	BCD digital I/P D8	0809	BCD digital I/P D16	0817	BCD digital I/P D24	0825
BCD digital I/P D1	0802	BCD digital I/P D9	0810	BCD digital I/P D17	0818	BCD digital I/P D25	0826
BCD digital I/P D2	0803	BCD digital I/P D10	0811	BCD digital I/P D18	0819	BCD digital I/P D26	0827
BCD digital I/P D3	0804	BCD digital I/P D11	0812	BCD digital I/P D19	0820	BCD digital I/P D27	0828
BCD digital I/P D4	0805	BCD digital I/P D12	0813	BCD digital I/P D20	0821	BCD digital I/P D28	0829
BCD digital I/P D5	0806	BCD digital I/P D13	0814	BCD digital I/P D21	0822	BCD digital I/P D29	0830
BCD digital I/P D6	0807	BCD digital I/P D14	0815	BCD digital I/P D22	0823	BCD digital I/P D30	0831
BCD digital I/P D7	0808	BCD digital I/P D15	0816	BCD digital I/P D23	0824	BCD digital I/P D31	0832

Table B.10 BCD Encoded Digital Inputs

Read Only. 0 = Real time alarm inactive  
1 = Real time alarm active

Title	Coil Number
Real Time Alarm 1	0851
Real Time Alarm 2	0852
Real Time Alarm 3	0853
Real Time Alarm 4	0854

Table B.11 Real Time Alarms

Signal		Channel Number											
		Process Group 1						Process Group 2					
		1.1	1.2	1.3	1.4	1.5	1.6	2.1	2.2	2.3	2.4	2.5	2.6
Channel Fail State	R	1001	1021	1041	1061	1081	1101	1121	1141	1161	1181	1201	1221
Alarm A State	R	1002	1022	1042	1062	1082	1102	1122	1142	1162	1182	1202	1222
Alarm B State	R	1003	1023	1043	1063	1083	1103	1123	1143	1163	1183	1203	1223
Alarm A Acknowledge	R/W	1004	1024	1044	1064	1084	1104	1124	1144	1164	1184	1204	1224
Alarm B Acknowledge	R/W	1005	1025	1045	1065	1085	1105	1125	1145	1165	1185	1205	1225
Totalizer Stop/Go	R/W	1006	1026	1046	1066	1086	1106	1126	1146	1166	1186	1206	1226
Totalizer Reset	R/W	1007	1027	1047	1067	1087	1107	1127	1147	1167	1187	1207	1227
Totalizer Wrap	R	1008	1028	1048	1068	1088	1108	1128	1148	1168	1188	1208	1228
Totalizer First Stage	R	1009	1029	1049	1069	1089	1109	1129	1149	1169	1189	1209	1229
Totalizer Flowrate Fail	R	1010	1030	1050	1070	1090	1110	1130	1150	1170	1190	1210	1230
Reserved		1011 to 1020	1031 to 1040	1051 to 1060	1071 to 1080	1091 to 1100	1111 to 1120	1131 to 1140	1151 to 1160	1171 to 1180	1191 to 1200	1211 to 1220	1231 to 1240

Table B.12 Channel Digital Signals

## B.6 Operating Mode Modbus Registers

Tables B.13 to B.18 detail the contents of the Modbus registers accessible while the instrument is in the operating mode.

Two data types are used:

- 32-bit single precision floating point data in IEEE format
- 64-bit double precision floating point data in IEEE format

### Note.

- When writing to a parameter that occupies more than one register position then all registers relating to that parameter **MUST** be written to as part of a multiple register write. If this is not achieved a NAK exception response is issued. Individual registers can be read without causing an exception response.
- When accessing a parameter that occupies more than one register position, the lowest numbered register contains the most significant data.

Analog Inputs	Modbus Registers Read only, single precision floating point number -999 to +9999
A1	0001 and 0002
A2	0003 and 0004
A3	0005 and 0006
A4	0007 and 0008
A5	0009 and 0010
A6	0011 and 0012
B1	0013 and 0014
B2	0015 and 0016
B3	0017 and 0018
B4	0019 and 0020
B5	0021 and 0022
B6	0023 and 0024
Reserved	0025 to 0100

Table B.13 Analog Inputs

Trip Point Registers (single precision floating point) Read: -999 to +9999 Write: -999 to +9999
--

Alarm Number and Name	Registers	
1	Alarm 1.1A	0101 and 0102
2	Alarm 1.1B	0103 and 0104
3	Alarm 1.2A	0105 and 0106
4	Alarm 1.2B	0107 and 0108
5	Alarm 1.3A	0109 and 0110
6	Alarm 1.3B	0111 and 0112
7	Alarm 1.4A	0113 and 0114
8	Alarm 1.4B	0115 and 0116
9	Alarm 1.5A	0117 and 0118
10	Alarm 1.5B	0119 and 0120
11	Alarm 1.6A	0121 and 0122
12	Alarm 1.6B	0123 and 0124
13	Alarm 2.1A	0125 and 0126
14	Alarm 2.1B	0127 and 0128
15	Alarm 2.2A	0129 and 0130
16	Alarm 2.2B	0131 and 0132
17	Alarm 2.3A	0133 and 0134
18	Alarm 2.3B	0135 and 0136
19	Alarm 2.4A	0137 and 0138
20	Alarm 2.4B	0139 and 0140
21	Alarm 2.5A	0141 and 0142
22	Alarm 2.5B	0143 and 0144
23	Alarm 2.6A	0145 and 0146
24	Alarm 2.6B	0147 and 0148
	Reserved	0149 to 0250

Table B.14 Alarm Trip Levels

		Modbus Registers							
		Current Batch				Previous Batch			
		Maximum Flowrate	Minimum Flowrate	Average Flowrate	Batch Total	Maximum Flowrate	Minimum Flowrate	Average Flowrate	Batch Total
		Read only, single precision floating point, D999 to +9999			Read only, double precision, unsigned 0 to +9999999999	Read only, single precision, floating point, D999 to +9999			Read only, double precision, unsigned 0 to +9999999999
1	Totalizer 1.1	0251 and 0252	0301 and 0302	0351 and 0352	0401 to 0404	0551 and 0552	0601 and 0602	0651 and 0652	0701 to 0704
2	Totalizer 1.2	0253 and 0254	0303 and 0304	0353 and 0354	0405 to 0408	0553 and 0554	0603 and 0604	0653 and 0654	0705 to 0708
3	Totalizer 1.3	0255 and 0256	0305 and 0306	0355 and 0356	0409 to 0412	0555 and 0556	0605 and 0606	0655 and 0656	0709 to 0712
4	Totalizer 1.4	0257 and 0258	0307 and 0308	0357 and 0358	0413 to 0416	0557 and 0558	0607 and 0608	0657 and 0658	0713 to 0716
5	Totalizer 1.5	0259 and 0260	0309 and 0310	0359 and 0360	0417 to 0420	0559 and 0560	0609 and 0610	0659 and 0660	0717 to 0720
6	Totalizer 1.6	0261 and 0262	0311 and 0312	0361 and 0362	0421 to 0424	0561 and 0562	0611 and 0612	0661 and 0662	0721 to 0724
7	Totalizer 2.1	0263 and 0264	0313 and 0314	0363 and 0364	0425 to 0428	0563 and 0564	0613 and 0614	0663 and 0664	0725 to 0728
8	Totalizer 2.2	0265 and 0266	0315 and 0316	0365 and 0366	0429 to 0432	0565 and 0566	0615 and 0616	0665 and 0666	0729 to 0732
9	Totalizer 2.3	0267 and 0268	0317 and 0318	0367 and 0368	0433 to 0436	0567 and 0568	0617 and 0618	0667 and 0668	0733 to 0736
10	Totalizer 2.4	0269 and 0270	0319 and 0320	0369 and 0370	0437 to 0440	0569 and 0570	0619 and 0620	0669 and 0670	0737 to 0740
11	Totalizer 2.5	0271 and 0272	0321 and 0322	0371 and 0372	0441 to 0444	0571 and 0572	0621 and 0622	0671 and 0672	0741 to 0744
12	Totalizer 2.6	0273 and 0274	0323 and 0324	0373 and 0374	0445 to 0448	0574 and 0575	0623 and 0624	0673 and 0674	0745 to 0748
	Reserved	0275 to 0300	0325 to 0350	0375 to 0400	0449 to 0550	0576 to 0600	0625 to 0650	0675 to 0700	0749 to 0850

Table B.15 Totalizer Totals

### B.7 Comms. Analog and Digital Inputs

Input Number	Comms. Digital Inputs	Comms. Analog Inputs Failure	Comms. Analog Inputs
	Read/Write: 0 = Inactive 1 = Active		Floating point (-999 to 9999)
Input Number	Coil Number	Coil Number	Registers
1	0601	0651	0851 and 0852
2	0602	0652	0853 and 0854
3	0603	0653	0855 and 0856
4	0604	0654	0857 and 0858
5	0605	0655	0859 and 0860
6	0606	0656	0861 and 0862
7	0607	0657	0863 and 0864
8	0608	0658	0865 and 0866
9	0609	0659	0867 and 0868
10	0610	0660	0869 and 0870
11	0611	0661	0871 and 0872
12	0612	0662	0873 and 0874
13	0613	0663	0875 and 0876

Input Number	Comms. Digital Inputs	Comms. Analog Inputs Failure	Comms. Analog Inputs
	Read/Write: 0 = Inactive 1 = Active		Floating point (-999 to 9999)
Input Number	Coil Number	Coil Number	Registers
14	0614	0664	0877 and 0878
15	0615	0665	0879 and 0880
16	0616	0666	0881 and 0882
17	0617	0667	0883 and 0884
18	0618	0668	0885 and 0886
19	0619	0669	0887 and 0888
20	0620	0670	0889 and 0890
21	0621	0671	0891 and 0892
22	0622	0672	0893 and 0894
23	0623	0673	0895 and 0896
24	0624	0674	0897 and 0898
Reserved	0625 to 0650	0675 to 0700	0899 to 1000

Table B.16 Modbus Inputs

Read/ Write: ASCII Character Code – see Table B.18			
Input	Register Number	Input	Register Number
Character 1	0951	Character 11	0961
Character 2	0952	Character 12	0962
Character 3	0953	Character 13	0963
Character 4	0954	Character 14	0964
Character 5	0955	Character 15	0965
Character 6	0956	Character 16	0966
Character 7	0957	Character 17	0967
Character 8	0958	Character 18	0968
Character 9	0959	Character 19	0969
Character 10	0960	Character 20	0970

Table B.17 Remote Operator Messages

Hex	Dec	Char	Hex	Dec	Char	Hex	Dec	Char	Hex	Dec	Char	Hex	Dec	Char
20	32	Space	34	52	4	47	71	G	5A	90	Z	6D	109	m
21	33	!	35	53	5	48	72	H	5B	91	[	6E	110	n
22	34	“	36	54	6	49	73	I	5C	92	\	6F	111	o
23	35	#	37	55	7	4A	74	J	5D	93	]	70	112	p
24	36	\$	38	56	8	4B	75	K	5E	94	^	71	113	q
25	37	%	39	57	9	4C	76	L	5F	95	_	72	114	r
26	38	&	3A	58	:	4D	77	M	60	96	N/A	73	115	s
27	39	`	3B	59	;	4E	78	N	61	97	a	74	116	t
28	40	(	3C	60	<	4F	79	O	62	98	b	75	117	u
29	41	)	3D	61	=	50	80	P	63	99	c	76	118	v
2A	42	*	3E	62	>	51	81	Q	64	100	d	77	119	w
2B	43	+	3F	63	?	52	82	R	65	101	e	78	120	x
2C	44	N/A	40	64	@	53	83	S	66	102	f	79	121	y
2D	45	-	41	65	A	54	84	T	67	103	g	7A	122	z
2E	46	.	42	66	B	55	85	U	68	104	h	7B	123	{
2F	47	/	43	67	C	56	86	V	69	105	i	7C	124	
30	48	0	44	68	D	57	87	W	6A	106	j	7D	125	}
31	49	1	45	69	E	58	88	X	6B	107	k	7E	126	~
32	50	2	46	70	F	59	89	Y	6C	108	l	7F	127	N/A
33	51	3												

Hex	Dec	Char
A3	163	£
B0	176	°
B2	178	²
B3	179	³
B5	181	μ
3A9	937	Ω

**Note.** Character codes 2C, 60 and 7F Hex (44, 96 and 127 Dec) are not supported

Table B.18 ASCII Character Set for Remote Operator Messages

## Appendix C – Storage Capacity

### C.1 Internal Storage Capacity

Sample Rate	Number of Channels			
	3	6	9	12
0.1 seconds	4.5 hours	2.3 hours	1.5 hours	1.1 hours
0.2 seconds	9.1 hours	4.5 hours	3.0 hours	2.3 hours
0.3 seconds	13.6 hours	6.8 hours	4.5 hours	3.4 hours
0.4 seconds	18.2 hours	9.1 hours	6.1 hours	4.5 hours
0.5 seconds	22.7 hours	11.4 hours	7.6 hours	5.7 hours
0.6 seconds	1.1 days	13.6 hours	9.1 hours	6.8 hours
0.7 seconds	1.3 days	15.9 hours	10.6 hours	8.0 hours
0.8 seconds	1.5 days	18.2 hours	12.1 hours	9.1 hours
0.9 seconds	1.7 days	20.5 hours	13.6 hours	10.2 hours
1.0 second	1.9 days	22.7 hours	15.2 hours	11.4 hours
2.0 seconds	3.8 days	1.9 days	1.3 days	22.7 hours
3.0 seconds	5.7 days	2.8 days	1.9 days	1.4 days
4.0 seconds	7.6 days	3.8 days	2.5 days	1.9 days
5.0 seconds	9.5 days	4.7 days	3.2 days	2.4 days
6.0 seconds	11.4 days	5.7 days	3.8 days	2.8 days
7.0 seconds	13.3 days	6.6 days	4.4 days	3.3 days
8.0 seconds	15.2 days	7.6 days	5.1 days	3.8 days
9.0 seconds	17.1 days	8.5 days	5.7 days	4.3 days
10.0 seconds	19.0 days	9.5 days	6.3 days	4.7 days
1.0 minute	3.7 months	1.9 months	1.2 months	28.4 days
10.0 minutes	37.4 months	18.7 months	12.5 months	9.3 months
1.0 hour	18.7 years	9.3 years	6.2 years	4.7 years
12.0 hours	224.4 years	112.2 years	74.7 years	56.0 years

Table C.1 Internal Storage Capacity

## C.2 Archive Storage Capacity

**Note.** The storage capacity times shown are for archiving of a single group. If two groups are archived, the durations are halved.

Sample Rate	Media Size			
	128 Mb	256 Mb	512 Mb	1 Gb
0.1 seconds	2.7 days	5.4 days	1.5 weeks	3.0 weeks
0.2 seconds	5.4 days	1.5 weeks	3.1 weeks	1.4 months
0.3 seconds	8.0 days	2.3 weeks	4.6 weeks	2.1 months
0.4 seconds	1.5 weeks	3.1 weeks	6.1 weeks	2.8 months
0.5 seconds	1.9 weeks	3.8 weeks	7.7 weeks	3.5 months
0.6 seconds	2.3 weeks	1.1 months	2.1 months	4.2 months
0.7 seconds	2.7 weeks	1.2 months	2.5 months	4.9 months
0.8 seconds	3.1 weeks	1.4 months	2.9 months	5.6 months
0.9 seconds	3.4 weeks	1.6 months	3.2 months	6.3 months
1.0 second	1.0 month	2.0 months	3.6 months	7.0 months
2.0 seconds	2.0 months	3.5 months	7.0 months	14.0 months
3.0 seconds	3.0 months	5.0 months	10.0 months	20.0 months
4.0 seconds	3.5 months	7.0 months	14.0 months	28.0 months
5.0 seconds	4.5 months	9.0 months	18.0 months	35.0 months
6.0 seconds	5.0 months	11.0 months	21.0 months	42.0 months
7.0 seconds	6.0 months	12.5 months	25.0 months	4.0 years
8.0 seconds	7.0 months	14.0 months	2.08 months	4.5 years
9.0 seconds	8.0 months	16.0 months	32.0 months	5.2 years
10.0 seconds	9.0 months	18.0 months	3.0 years	5.7 years
1.0 minute	4.0 years	8.0 years	17.0 years	34.0 years
10.0 minutes	44.0 years	88.0 years	176.0 years	344.0 years

Table C.2 External (Archive) Storage Capacity – Text Formatted Archive Files

Sample Rate	Media Size			
	128 Mb	256 Mb	512 Mb	1 Gb
0.1 seconds	1.7 weeks	3.5 weeks	1.6 months	3.2 months
0.2 seconds	3.5 weeks	1.6 months	3.2 months	6.3 months
0.3 seconds	5.2 weeks	2.4 months	4.9 months	9.5 months
0.4 seconds	1.6 months	3.2 months	6.5 months	1.0 year
0.5 seconds	2.0 months	4.0 months	8.0 months	1.3 years
0.6 seconds	2.4 months	4.9 months	9.7 months	1.6 years
0.7 seconds	2.8 months	5.7 months	11.3 months	1.8 years
0.8 seconds	3.2 months	6.5 months	12.9 months	2.1 years
0.9 seconds	3.6 months	7.0 months	1.2 years	2.3 years
1.0 second	4.0 months	8.0 months	16.2 months	2.6 years
2.0 seconds	8.0 months	1.3 years	2.7 years	5.2 years
3.0 seconds	12.0 months	2.0 years	4.0 years	7.8 years
4.0 seconds	16.0 months	2.7 years	5.3 years	10.4 years
5.0 seconds	20.0 months	3.3 years	6.7 years	13.0 years
6.0 seconds	2.0 years	4.0 years	8.0 years	15.6 years
7.0 seconds	2.3 years	4.7 years	9.3 years	18.2 years
8.0 seconds	2.7 years	5.3 years	10.6 years	20.8 years
9.0 seconds	3.0 years	6.0 years	12.0 years	23.4 years
10.0 seconds	3.3 years	6.7 years	13.3 years	26.0 years
1.0 minute	20.0 years	39.0 years	79.8 years	155.9 years
10.0 minutes	199.0 years	399.0 years	798.0 years	1558.6 years

Table C.3 External (Archive) Storage Capacity – Binary Formatted Archive Files

## Appendix D – Default Settings

### D.1 Company Standard

#### D.1.1 Common Configuration

##### Setup

Configuration type	Basic
Number of groups	1
Language	English
Global alarm ack source	None
Instrument tag	SM1000

##### Screen

Screen saver wait time	Disabled
Screen Capture	Disabled

##### Time

Date format	DD/MM/YY
Time format	HH:MM:SS
Daylight Saving – Enable	Off

##### Security

Security system	Basic
Configuration security	Password protected
Setup level security	Off
Reconfigure preset	No
Password expiry	Disabled
Inactive user disabling	Off
Password failure limit	Infinite
Min password length	4 characters

##### User

User names	Operator 1, 2 etc.
User access	
User 1	Full access
All other users	Access disabled
User passwords	
User 1	Blank
All other users	4 spaces

##### Logs

Alarm log size	100	
Totalizer log size	200	•1
Audit log size	100	

##### Operator messages (all)

Tag	–
Message source ID	None
Assign to group 1	Yes
Assign to group 2	Yes

#### D.1.2 Process Groups 1 to 6

##### Recording

Group 1 tag	Process Group 1
Group 2 tag	Process Group 2
Recording enable source	None
Primary sample rate	10.0 sec
Secondary sample rate	1.0 sec
Sample rate select source	None

##### Chart View

Chart view enable	Vertical
Chart annotation	None
Major chart divisions	5
Minor chart divisions	2
Trace pointers	Enabled
Screen interval	3 minutes/screen
Trace width	1

##### Menu enables

Message select	False
Alarm acknowledge	True
Scale select	False
Trace select	False
Screen interval select	True
Historical review	True
Chart annotation select	False

##### Bargraph View

Bargraph view enable	Off
Bargraph markers	No markers
Menu enables	
Message select	False
Alarm acknowledge	True
Max/min reset	False

##### Process View

Process view enable	Off
View select	Statistics
Menu enables	
Message select	False
Alarm acknowledge	True
Totalizer reset	False
Totalizer stop/go	False
View select	False

##### Digital Indicator View

Digital indicator view enable	Off
Totalizer display enable	Off
Menu enables	
Message select	False
Alarm acknowledge	True
Totalizer reset	False
Totalizer stop/go	False
Channel select	False

##### Archiving

Archive file format	Text format
Archive file enables	
Channel data file	False
Alarm event log file	False
Totalizer log file	False
Audit log file	False
Filename tag	Process Group 1
New file interval	Daily
Wrap	Off

•1 Applicable only if the Totalizer option is enabled

### D.1.3 Recording Channels

<b>Setup</b>		<b>Totalizers</b>		•1
Source indentifiers		Count enable	Off	
Channels 1.1 to 1.6	Analog input A1 to A6	Wrap enable	On	
Channels 2.1 to 2.6	Analog input B1 to B6	Channel x.x totalizer tag	Total flow x.x	
Trace colors		Units	Blank	
Channels 1.1 and 2.1	Magenta	Stop/Go		
Channels 1.2 and 2.2	Red	Stop/Go recovery	Last	
Channels 1.3 and 2.3	Black	Stop/Go source	None	
Channels 1.4 and 2.4	Green	Count range		
Channels 1.5 and 2.5	Blue	Preset count	0	
Channels 1.6 and 2.6	Brown	Predetermined count	1000000000	
Zone (all channels)	Not zoned	Intermediate count	900000000	
Filter type (all channels)	Instantaneous	Reset source	None	
<b>Analog Inputs (A1 to A6 and B1 to B6)</b>		Log update		
Input type		Log update time	Off	
Type	milliamps	Log update source	None	
Linearizer Type	Linear	Count rate/Cut off		
Electrical range low	4.0	Count rate	1.00000	
Electrical range high	20.0	Cut off	0.0	
Engineering range		<b>D.1.4 I/O Modules</b>		
Low	0.0	<b>Analog input modules</b>		
High	100.0	Mains rejection frequency	50 Hz	
Units	%	<b>Relay modules (all sources)</b>		
Short tag	I/P xx	Source	None	
Long tag	Analog input xx	Polarity	Positive	
Filter time constant	0 Secs	<b>Hybrid modules</b>		
Fault detect level	10%	Digital outputs		
Broken sensor direction	Downscale	Source	None	
<b>Digital recording channels</b>		Polarity	Positive	
Digital on tag	On	Analog outputs		
Digital off tag	Off	Engineering low	0.0	
Short tag	Blank	Engineering high	100.0	
Long tag	Blank	Electrical low	4.0	
<b>Process Alarms (all channels)</b>		Electrical high	20.0	
Alarm type	Off	Analog output source	None	
Recording channel x.x alarm tag				
Alarm A tag	x.xA			
Alarm B tag	x.xB			
Trip	0.0 %			
Hysteresis				
Hysteresis	0.0 %			
Time hysteresis	0 Secs			
Enable source	None			
Log enable	Off			
Alarm group	All None			

•1 Applicable only if the Totalizer option is enabled

### D.1.5 Functions

#### Custom Linearizers 1 and 2

X co-ordinates 0.0, 5.0, 10.0, 15.0,  
20.0, 25.0, 30.0, 35.0,  
40.0, 45.0, 50.0, 55.0,  
60.0, 65.0, 70.0, 75.0,  
80.0, 85.0, 90.0, 95.0,  
100.0

Y co-ordinates As X co-ordinates

#### Real-time Alarms 1 to 4

Alarm x tag Real Time Alarm x  
Daily enables  
(Sun, Mon, Tues etc.) None  
1st of month enable Off  
On time  
Every hour Off  
Hours 0  
Minutes 0  
Duration  
Hours 0  
Minutes 0  
Seconds 0  
Log enable Off

### D.2 QuickStart Templates

#### D.2.1 QSMilliAmp

As D.1 Company Standard except:

##### Bargraph View

Bargraph view enable Vertical  
Bargraph markers Max and min  
Menu enables  
Message select False  
Alarm acknowledge True  
Max/min reset True

##### Process View

Menu enables  
Alarm acknowledge True  
Totalizer reset True  
Totalizer stop/go True  
View select True

##### Digital Indicator View

Digital indicator view enable On

##### Archiving

Archive file enables  
Channel data file True  
New file interval Hourly

### D.2.2 QSFlow

As D.2.1 QSMilliAmp, except:

#### Analog Inputs (A1 to A6 and B1 to B6)

Engineering range  
Low 0  
High 2000  
Units l/h

#### Totalizers

Count enable Count up  
Count range  
Preset count 0.0  
Predetermined count 100000000.0  
Intermediate count 90000000.0  
Count rate/Cut off  
Count rate 0.55556

#### Hybrid modules

Analog outputs  
Engineering high 2000

### D.2.3 QSTHC\_C

As D.2.1 QSMilliAmp except:

#### Analog Inputs (A1 to A6 and B1 to B6)

Input type  
Type Thermocouple  
Linearizer Type K  
Linearizer units Degrees C  
Engineering range  
Units °C

### D.2.4 QSTHC\_F

As D.2.3 QSTHC\_C except:

#### Analog Inputs (A1 to A6 and B1 to B6)

Engineering range  
Units °F

### D.2.5 QSRTD\_C

As D.2.3 QSTHC\_C except:

#### Analog Inputs (A1 to A6 and B1 to B6)

Input type  
Type Resistance thermometer  
Linearizer Type Pt 100

### D.2.6 QSRTD\_F

As D.2.5 QSRTD\_C except:

#### Analog Inputs (A1 to A6 and B1 to B6)

Engineering range  
Units °F

•1 Applicable only if the Totalizer option is enabled

## D.2.7 QSDEMO

As D.1 Company Standard except:

### Screen

Screen Capture Enabled

### Operator messages

Message 1 Start of batch  
 Message 2 End of batch  
 Message 3 Standby mode active  
 Message 4 Cleaning in progress

### Chart View

Menu enables  
 Message select True  
 Scale select True  
 Trace select True  
 Chart annotation select True

### Bargraph View

Bargraph view enable Horizontal and vertical  
 Markers Max, min and alarm trips  
 Menu enables  
 Message select True  
 Max/min reset True

### Process View

Process view enable Off  
 Menu enables  
 Message select True  
 Totalizer reset True •1  
 Totalizer stop/go True •1  
 View select True

### Digital Indicator View

Digital indicator view enable Off  
 Menu enables  
 Message select True

### Archiving

Archive file enables  
 Channel data file True  
 Alarm event log file True  
 Totalizer log file True •1  
 Audit log file True  
 New file interval Hourly

### Recording Channel Setup

Source identifiers  
 Channels 1.1 to 1.5 Analog input A1 to A5  
 Channel 1.6 Alarm State 1.1A

### Analog Inputs (A1 to A5)

Input type  
 Type Simulated sine wave  
 Engineering range units  
 Ch1.1 °C  
 Ch1.2 bar  
 Ch1.3 Gal/h  
 Ch1.4 Litres  
 Ch1.5 °F  
 Short tags  
 Ch1.1 Temp 1  
 Ch1.2 Pressure  
 Ch1.3 In Flow  
 Ch1.4 Volume  
 Ch1.5 Temp 2

### Alarm State 1.1A (Digital Recording Channel 1.6)

Digital on tag Open  
 Digital off tag Close  
 Short tag Valve  
 Long tag Valve status

### Ch1.1 Alarm A

Alarm type High process  
 Trip 10.0 °C  
 Log enable On

### Ch1.1 Totalizer

Count enable Count up •1  
 Log update  
 Log update time 60 min

### Real-time Alarms 1 to 4

Daily enables Mo,Tu,We,Th,Fr  
 On time  
 Every hour On  
 Duration  
 Minutes 10  
 Log enable On

•1 Applicable only if the Totalizer option is enabled

### D.2.8 QSDAIRY

As D.2.5 QSRTD\_C except:

#### Recording

Primary sample rate 1 min

#### Chart View

Screen interval 2 days/screen

#### Bargraph View

Bargraph view enable Off

#### Archiving

Archive file enables

Alarm event log file True

Audit log file True

New file interval Daily

#### Recording Channel Setup

Source identifiers

Channel 1.1 Analog input A1

Channel 1.2 Analog input A2

All other channels None

#### Analog Input A1

Engineering range

Low -10.0

High 90.0

Units °C

Short tag Tank

Long tag Tank Temperature

Broken sensor direction Upscale

#### Analog Input A2

Engineering range

Low -10.0

High 90.0

Units °C

Short tag Return

Long tag Return Temperature

Broken sensor direction Upscale

#### Ch1.1 Alarm A

Alarm type Delayed high process

Trip 10.0 °C

Hysteresis/Delay time

Hysteresis 0.5 °C

Delay time 7200 Secs

Enable source Digital I/P C1

Log enable On

#### Ch1.1 Alarm B

Alarm type Delayed high process

Trip 12.0 °C

Hysteresis/Delay time

Hysteresis 0.5 °C

Delay time 1200 Secs

Enable source Digital I/P C2

Log enable On

#### Relay modules

Source

Relay C1 Logic equation 1

Relay C2 None

Relay C3 None

Polarity +ve

- 1 Applicable only if the Totalizer option is enabled

## Appendix E – Spare Parts and Accessories

### Media Door Keys

GR2000/0725



### Panel Clamp

GR2000/0723



### Voltage Divider Board

GR2000/0375

(inc. 250Ω shunt GR2000/0377)



### Compact Flash Card

512Mb

1Gb

2GB

B12156

B12567

B12568



### USB Universal Card Reader

B12028



### Documentation Pack

User Guide (this manual)

Quick reference guide

End User Licence Agreement

Data Sheet

IM/SM1000

IM/SM1000-Q

IM/SM2000-L

SS/SM1000

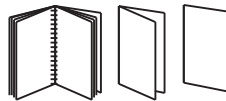

**20-way Terminal Block**

for analog input modules: GR2000/0726  
for other modules: GR2000/0727



**8-way Terminal Block**

GR2000/0728



**Instrument to Panel Seal**

PR100/0186



**Terminal Compartment**

GR2000/0716

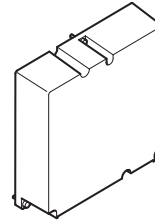

**Removable Media Options** (in place of existing option, if fitted)

Compact Flash upgrade pack GR2000/1700  
SmartMedia upgrade pack GR2000/1702

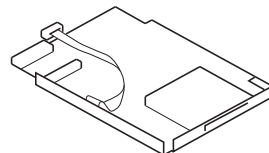

**Optional I/O Boards**

(Max. 4, including factory-fitted option boards – see Fig. 5.5 on page 99 for possible combinations)

3-Relay board upgrade pack GR2000/0703  
6-Relay board upgrade pack GR2000/0704  
Hybrid I/O board upgrade pack GR2000/0705  
Transmitter PSU board upgrade pack GR2000/0706  
6-Channel standard analog I/P board upgrade pack GR2000/0708  
6-Channel high specification analog I/P board upgrade pack GR2000/0714  
RS485 serial communications board upgrade pack GR2000/1722  
Ethernet board upgrade pack GR2000/0722

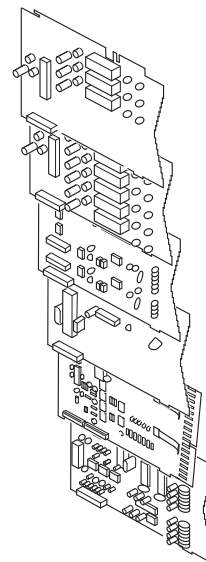

## Appendix F – Error & Diagnostics Information

Error Message	Action
"The system has not finished updating the files in the storage card folder. Please re-insert the storage card now. WARNING: Failure to do so may result in lost data on the storage card."	Re-insert the storage card immediately and press the  key to clear the error message.
"Would you like the system to format the storage card folder so that the system can use it? WARNING: If you select Yes, all files on the storage card folder will be erased!"	Remove the card from the recorder and format the card on a PC before reinserting.
"Disk removed before signature sign" message appears in audit log.	Caused by static damage to media card. Format or replace current card. Observe anti-static precautions when handling.

# Appendix G – Symbols and Icons

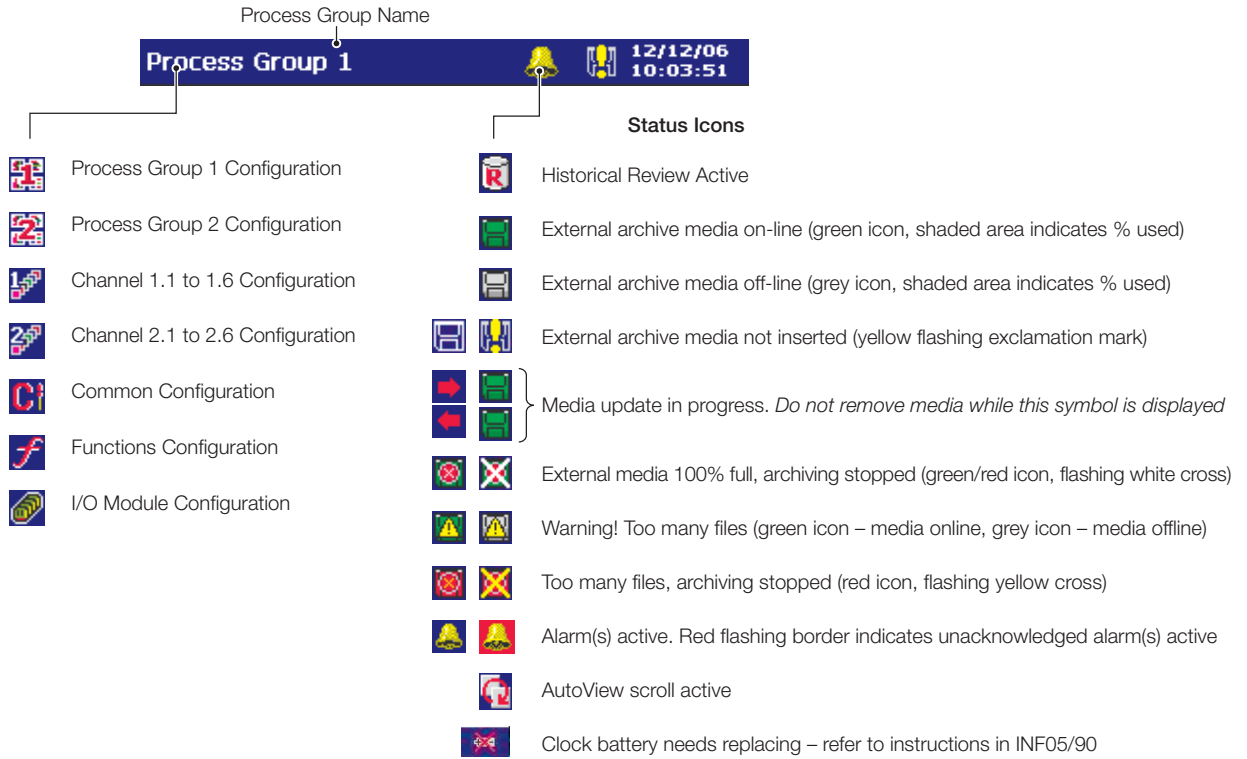

Alarm Event Icons	
Inactive	Active
	High Process Alarm
	Low Process Alarm
	Delayed High Process Alarm
	Delayed Low Process Alarm
	High Latch Alarm
	Low Latch Alarm
	Fast Rate Alarm
	Slow Rate Alarm
	High Annunciate Alarm
	Low Annunciate Alarm
	Real Time Alarm
	Daylight Saving Start/End Changed
	Alarm Acknowledged
	Operator Message

Totalizer Icons	
	Totalizer Started
	Totalizer Stopped
	Totalizer Wrapped
	Totalizer Reset
	Intermediate Value Reached
	Timed Event
	Triggered Event
	Power Failed
	Power Restored
	Batch Total
	Maximum Value
	Minimum Value
	Average Value
	Daylight Saving Start/End Changed

Audit Log Icons	
	Power Failed
	Power Restored
	Calibration Change
	Configuration Change
	File Created
	File Deleted
	Archive Media Inserted
	Archive Media Removed
	Archive Media Off-line
	Archive Media On-line
	Archive Media Full
	System Error/Reset Archiving
	Date/Time or Daylight Saving Start/End Changed
	FTP Logon
	Electronic Signature
	Security Change

## Index

- A**
- Accessories .....3, 124
  - Advanced Security – See Security System: Advanced
  - Alarm Event Log .....23, 24
    - Filter .....24
    - Size .....60
  - Alarms .....8
    - Acknowledging ..... 13, 16, 19, 22, 24, 52, 65, 66, 67, 69, 94
    - Annunciate .....79, 81
    - Delayed Process .....80, 82
    - Event .....8
    - Groups .....83, 105
    - Hysteresis .....59, 81
    - Latch .....78, 81
    - New Alarm .....8, 105
    - Process .....78, 81
    - Rate .....79, 82
    - Real-time .....88
    - State Recording .....83
    - Tag .....81
    - Type .....81
  - Analog Inputs
    - Connections .....100
    - High Specification Inputs .....74, 75, 100
    - Volt Free Digital Input .....74, 77
  - Analog Outputs
    - Connections .....103
  - Archiving
    - Archive File Format .....70
    - Archive Wrap .....44, 71
    - Channel Data Files .....33, 36, 70
    - Data Verification and Integrity .....41
    - File Names .....37
    - File Types .....36
    - Log Files .....41
    - Media Off-line .....29, 44
    - Media On-line .....29, 44
    - Off-line .....33
    - On-line .....33
    - Reset .....32
    - Sample Rates .....70
    - Too Many Files – Archiving Stopped .....44
    - Warning – Too Many Files .....44
  - Assign to Group
    - Electronic Signatures .....14
  - Audit Log .....27, 36, 60, 70
  - AutoView Scroll – See Chart: AutoView Scroll
- B**
- Bargraph .....3, 15
    - Configuration .....66
    - Markers .....66
    - Max./Min. Reset .....16
    - Views
      - Enabling Menu Items .....66
  - Basic Security – See Security System: Basic
  - BCD (Binary Encoded) Digital Inputs .....94, 104
  - Binary Format Archive Files .....41 to 43
- C**
- Channel Indicator
    - Tags .....76, 77
  - Chart
    - Annotation .....11, 64
    - AutoView Scroll .....13, 16, 19, 22
    - Electronic Signature .....14, 59
    - Scales .....10, 13, 65
    - Traces .....8, 13, 65, 73
    - Views
      - Horizontal .....7
      - Vertical .....7
      - Zoning .....73
  - Configuration
    - Access .....45, 46
    - Alarms .....78 to 83
    - Analog Input .....74 to 77
      - Electrical Range .....75
      - Engineering Range .....76
      - Input Adjustment .....89
      - Input Failure .....77
    - Bargraph View .....66
    - Channel .....72 to 86
    - Chart View .....63 to 65
    - Common .....52 to 91
    - Company Standard .....119
    - Custom Linearizers .....87
    - Data Entry .....50
    - Digital Indicator View .....68
    - Digital Input .....77
    - Disabling Recording During Configuration .....46
    - Exiting Configuration Mode .....51
    - I/O Modules .....89 to 90
      - Analog Inputs .....89
      - Ethernet Module – See also Ethernet Option
        - User Guide Supplement, IM/SMENET .....90
      - Hybrid Modules .....94
      - Relay Modules .....90
      - RS485(Modbus) Module .....91
    - Internal Switch Protection .....45
    - Logs .....60
    - Number of Groups .....52
    - Operator Messages .....60
    - Overview .....48
    - Password Protection .....45
    - Process Group .....61 to 71
    - Process View .....67
    - Real Time Alarms .....88
    - Recording Channel Setup .....72 to 73
    - Recording Parameters .....61 to 62
    - Sample Rates .....62
    - Security .....45, 56 to 57
      - Access Privileges .....59
      - Inactive User De-activation .....57
      - Internal Switch .....45, 47
      - Passwords .....57
      - Type .....45, 56
      - View/Edit Other Users .....58, 59
    - Totalizers .....84 to 86
    - Type .....52

**D**

Date and Time ..... 54 to 55  
 Daylight Saving ..... 10, 41, 55  
 Digital Indicator View ..... 17  
     Channel Select ..... 18  
     Menu Items Enabling ..... 69  
     Totalizer Reset ..... 19  
     Totalizer Stop/Go ..... 19  
 Digital Inputs  
     Connections ..... 103  
     Volt Free Digital Input ..... 74, 77  
 Digital Outputs  
     Connections ..... 103

**E**

Electrical Connections ..... 98 to 103  
 Electronic Signature – See Chart: Electronic Signature  
 Environmental Limits ..... 96  
 Error Messages ..... 126  
 Ethernet – See *also* Ethernet Option  
     User Guide Supplement, IM/SMENET ..... 90

**F**

File Viewer ..... 33  
 Filter  
     Mains Rejection Frequency ..... 89  
     Recording Channel Input ..... 73  
     Filter Time ..... 77  
 Functions ..... 87 to 88

**H**

Historical Review ..... 9, 11, 12, 33  
     Enable ..... 65  
     Exit ..... 10  
     Goto ..... 10  
 Hybrid I/O Modules ..... 94  
     Connections ..... 103

**I**

Input Adjustment ..... 59, 89  
 Installation ..... 96 to 103  
     Electrical Connections ..... 98 to 103  
     Fitting the Instrument ..... 97  
     Mounting Dimensions ..... 97  
 Instrument Status ..... 28  
 Instrument Tag ..... 52

**L**

Language ..... 52  
 Linearizer Type ..... 75  
 Linearizer Units ..... 75  
 Log Sizes ..... 60

**M**

Mains Power Connections ..... 102  
 Mains Rejection Frequency ..... 89  
 Modbus (RS485) ..... 91 to 93  
     Baud Rate ..... 91  
     Character Set for Remote Operator Messages ..... 115  
     Master  
         Poll Limit ..... 91  
         Poll Rate ..... 91  
         Response Timeout ..... 91  
         RTU Address ..... 92  
         RTU address ..... 93  
     Modbus Inputs ..... 114  
     Parity ..... 91  
     Protocol ..... 91  
     Remote Operator Messages ..... 114  
     Slave Address ..... 91  
 Modbus TCP – See *also* Ethernet Option  
     User Guide Supplement, IM/SMENET ..... 95  
 Module Positions ..... 99

**O**

Offset Adjust ..... 90  
 Operator Messages  
     Alarm Event Log ..... 24, 60  
     Bargraph View ..... 16, 18, 21  
     Chart View ..... 11, 64, 65  
     Message Tag ..... 60  
     Source ID ..... 60  
     User Defined ..... 11, 16, 18, 21

**P**

Passwords  
     Entering ..... 31  
     Entry Failure Limit ..... 57  
     Expiry ..... 31, 57  
     Length ..... 57  
 Primary and Secondary Sample Rates ..... 12, 29,  
     ..... 32, 51, 62, 70  
 Process Group Tag ..... 61  
 Process View ..... 20 to 22  
     Menu Items Enabling ..... 67  
     Totalizer Reset ..... 22  
     Totalizer Stop/Go ..... 21

<b>Q</b>		<b>T</b>	
QuickStart Templates .....	121 to 123	Text Format Archive Files .....	37 to 40
<b>R</b>		Thermocouple Compensating Cable .....	90, 100, 102
Real-time Alarms .....	88	Totalizer Log .....	25 to 26
Recording Parameters .....	61 to 62	Configuration .....	60
Relay Connections .....	102	Filter .....	26
Reset Archiving – See Archiving: Reset		Update Frequency .....	85
Resistance Thermometer (RTD) .....	75, 76, 100	Totalizers	
<b>S</b>		Count Direction .....	84
Sample Rates – See Primary and Secondary Sample Rates		Count Rate .....	86
Scales – See Chart: Scales		Preset Count .....	85
Screen		Tag .....	84
Interval .....	65	Units .....	84
Screen Capture .....	3, 8, 53	Wrap .....	84
Screen Interval .....	12, 32	Trace	
Select Enable .....	65	Color .....	73
Screen Saver .....	53	Width .....	65
Security system		Transmitter Power Supply .....	100
Advanced .....	29, 30		
Basic .....	29, 56, 58		
Setup Level			
Accessing .....	29		
Passwords .....	31		
Menu .....	32		
Recording Control .....	32		
Signal Sources .....	104		
Simulated Inputs .....	74		
Siting .....	96		
Span Adjust .....	90		
Spare Parts and Accessories .....	124		
Storage Capacity			
External Media .....	117		
Internal Memory .....	116		
System Administrator .....	30, 46, 56, 57, 60		

# PRODUCTS & CUSTOMER SUPPORT

## Products

### Automation Systems

- for the following industries:
  - Chemical & Pharmaceutical
  - Food & Beverage
  - Manufacturing
  - Metals and Minerals
  - Oil, Gas & Petrochemical
  - Pulp and Paper

### Drives and Motors

- AC and DC Drives, AC and DC Machines, AC Motors to 1kV
- Drive Systems
- Force Measurement
- Servo Drives

### Controllers & Recorders

- Single and Multi-loop Controllers
- Circular Chart and Strip Chart Recorders
- Paperless Recorders
- Process Indicators

### Flexible Automation

- Industrial Robots and Robot Systems

### Flow Measurement

- Electromagnetic Flowmeters
- Mass Flowmeters
- Turbine Flowmeters
- Wedge Flow Elements

### Marine Systems & Turbochargers

- Electrical Systems
- Marine Equipment
- Offshore Retrofit and Refurbishment

### Process Analytics

- Process Gas Analysis
- Systems Integration

### Transmitters

- Pressure
- Temperature
- Level
- Interface Modules

### Valves, Actuators and Positioners

- Control Valves
- Actuators
- Positioners

### Water, Gas & Industrial Analytics Instrumentation

- pH, Conductivity and Dissolved Oxygen Transmitters and Sensors
- Ammonia, Nitrate, Phosphate, Silica, Sodium, Chloride, Fluoride, Dissolved Oxygen and Hydrazine Analyzers
- Zirconia Oxygen Analyzers, Katharometers, Hydrogen Purity and Purge-gas Monitors, Thermal Conductivity

## Customer Support

We provide a comprehensive after sales service via a Worldwide Service Organization. Contact one of the following offices for details on your nearest Service and Repair Centre.

### UK

ABB Limited  
Tel: +44 (0)1480 475321  
Fax: +44 (0)1480 217948

### USA

ABB Inc.  
Tel: +1 215 674 6000  
Fax: +1 215 674 7183

### Client Warranty

Prior to installation, the equipment referred to in this manual must be stored in a clean, dry environment, in accordance with the Company's published specification.

Periodic checks must be made on the equipment's condition. In the event of a failure under warranty, the following documentation must be provided as substantiation:

1. A listing evidencing process operation and alarm logs at time of failure.
2. Copies of all storage, installation, operating and maintenance records relating to the alleged faulty unit.

Modbus is a registered trademark of the Modbus-IDA organization

Microsoft is a registered trademark of Microsoft Corporation in the United States and/or other countries

---

**ABB** has Sales & Customer Support expertise  
in over 100 countries worldwide

[www.abb.com](http://www.abb.com)

The Company's policy is one of continuous product  
improvement and the right is reserved to modify the  
information contained herein without notice.

Printed in UK (06.11)

© ABB (2011)



**ABB Limited**  
Howard Road, St. Neots  
Cambridgeshire  
PE19 8EU  
UK  
Tel: +44 (0)1480 475321  
Fax: +44 (0)1480 217948

**ABB Inc.**  
125 E. County Line Road  
Warminster  
PA 18974  
USA  
Tel: +1 215 674 6000  
Fax: +1 215 674 7183