



# ABB

## The Company

We are an established world force in the design and manufacture of instrumentation for industrial process control, flow measurement, gas and liquid analysis and environmental applications.

As a part of ABB, a world leader in process automation technology, we offer customers application expertise, service and support worldwide.

We are committed to teamwork, high quality manufacturing, advanced technology and unrivalled service and support.

The quality, accuracy and performance of the Company's products result from over 100 years experience, combined with a continuous program of innovative design and development to incorporate the latest technology.

The UKAS Calibration Laboratory No. 0255 is just one of the ten flow calibration plants operated by the Company and is indicative of our dedication to quality and accuracy.

EN ISO 9001:2000



Cert. No. Q 05907

EN 29001 (ISO 9001)



Lenno, Italy – Cert. No. 9/90A

Stonehouse, U.K.



0255

## Electrical Safety

This equipment complies with the requirements of CEI/IEC 61010-1:2001-2 'Safety Requirements for Electrical Equipment for Measurement, Control and Laboratory Use'. If the equipment is used in a manner NOT specified by the Company, the protection provided by the equipment may be impaired.

## Symbols

One or more of the following symbols may appear on the equipment labelling:

	<b>Warning</b> – Refer to the manual for instructions
	<b>Caution</b> – Risk of electric shock
	Protective earth (ground) terminal
	Earth (ground) terminal

	Direct current supply only
	Alternating current supply only
	Both direct and alternating current supply
	The equipment is protected through double insulation

Information in this manual is intended only to assist our customers in the efficient operation of our equipment. Use of this manual for any other purpose is specifically prohibited and its contents are not to be reproduced in full or part without prior approval of the Technical Publications Department.

### Health and Safety

To ensure that our products are safe and without risk to health, the following points must be noted:

1. The relevant sections of these instructions must be read carefully before proceeding.
2. Warning labels on containers and packages must be observed.
3. Installation, operation, maintenance and servicing must only be carried out by suitably trained personnel and in accordance with the information given.
4. Normal safety precautions must be taken to avoid the possibility of an accident occurring when operating in conditions of high pressure and/or temperature.
5. Chemicals must be stored away from heat, protected from temperature extremes and powders kept dry. Normal safe handling procedures must be used.
6. When disposing of chemicals ensure that no two chemicals are mixed.

Safety advice concerning the use of the equipment described in this manual or any relevant hazard data sheets (where applicable) may be obtained from the Company address on the back cover, together with servicing and spares information.

# CONTENTS

Section	Page	Section	Page
<b>WARNINGS AND INSTALLATION NOTES</b> .....	<b>2</b>	<b>8 DISMANTLING AND REASSEMBLY</b> .....	<b>17</b>
<b>1 INTRODUCTION</b> .....	<b>3</b>	8.1 Tools Required .....	17
1.1 Principle of Operation .....	3	8.2 Replacing the Ceramic Filter (all Probes) .....	17
<b>2 PREPARATION</b> .....	<b>5</b>	8.3 Removing the Zirconia Cell (all Probes) .....	17
2.1 Checking the Code Number .....	5	8.4 Fitting the Zirconia Cell (all Probes) .....	18
2.2 Accessories Check .....	5	8.5 Removing the Inner Assembly (all Probes) .....	19
2.2.1 Test Gas Connector Kit .....	5	8.6 Removing the Thermocouple/Electrode Lead Assembly (0.4 m Probes) .....	20
2.2.2 Probe Flanges .....	6	8.7 Fitting the Thermocouple/Electrode Lead Assembly (0.4 m Probes) .....	21
2.2.3 Mounting Plates .....	7	8.8 Replacing the Heater Assembly (0.4 m Probes) .....	22
2.2.4 Mounting Adapters (0.4 m Probes only) .....	7	8.9 Adjusting the Length of the Inner Assembly (all Probes) .....	23
<b>3 INSTALLATION</b> .....	<b>8</b>	8.10 Removing the Thermocouple/Electrode Lead Assembly (1.0 m, 1.5 m and 2.0 m Probes).....	24
3.1 Siting .....	8	8.11 Re-assembling the Thermocouple/Electrode Lead Components (1.0 m, 1.5 m and 2.0 m Probes) ....	25
3.2 Mounting .....	9	8.12 Fitting the Thermocouple/Electrode Lead Assembly (1.0 m, 1.5 m and 2.0 m Probes).....	27
3.2.1 0.4 m Probe (Flange 'Standard' Mounting) .....	9	8.13 Replacing the Heater Assembly (1.0 m, 1.5 m and 2.0 m Probes) .....	28
3.2.2 1.0 m, 1.5 m and 2.0 m Probes .....	9	8.14 Replacing the Connection Plate (1.0 m, 1.5 m and 2.0 m Probes) .....	29
3.2.3 0.4 m Probe (2½ in. Male Bush NPT Mounting) .....	10	8.15 Refitting the Inner Assembly and Aligning the Heater (all Probes) .....	30
3.2.4 0.4 m Probe (Z-LT Adapter Plate Mounting) .....	10	<b>9 SPECIFICATION</b> .....	<b>31</b>
<b>4 CONNECTIONS</b> .....	<b>11</b>	<b>10 SPARES LIST</b> .....	<b>32</b>
4.1 Conduit and Cable Details .....	11	10.1 0.4 m Probe Spares .....	32
4.2 Probe Connections – General .....	11	10.2 1.0 m, 1.5 m and 2.0 m Probe Spares .....	34
4.2.1 Accessing Probe Terminals .....	11	10.3 Conduit Assemblies .....	36
4.2.2 Probe Connections .....	12	10.3.1 Single Entry .....	36
4.3 Pipe Connections .....	14	10.3.2 Double Entry .....	36
4.3.1 External Reference Air Connection .....	14	10.4 Pump and Regulator Units for External Reference Air Supply .....	36
4.3.2 Vent Connection .....	14	10.5 Filter Deflector .....	36
4.3.3 Test Gas Inlet Connection .....	14	<b>APPENDICES</b> .....	<b>37</b>
<b>5 OPERATION</b> .....	<b>15</b>	A1 Removing a Welded Cell .....	37
5.1 Preparation .....	15	A2 Flow Through Sample Chamber (0.4 m Probes) ...	38
<b>6 CALIBRATION</b> .....	<b>15</b>	A3 Probe Checking Using the Nernst Equation .....	38
<b>7 FAULT FINDING</b> .....	<b>15</b>		
7.1 In Situ Probe Testing .....	15		
7.2 Bench Testing .....	16		

---

## WARNINGS AND INSTALLATION NOTES

---

### Warnings.

- **Handle the probe with care and do not subject it to hammer blows or other sharp shocks.** The probe inners have fragile ceramic components that are easily damaged.
  - **Remove the probe from the flue prior to cleaning the flue with a high pressure water hose or steam cleaning equipment.** Thermal shock **will** break the zirconia cell.
  - When starting a gas-fired boiler from cold, be aware that the condensation that results may be sufficient to damage the probe by thermal shock.
- 

### Installation Notes.

- If a deflector plate is required for use with a 0.4 m probe, use the 'Standard 0.4m Probe Adaptor Plate' shown in Fig. 2.8 together with the 'Long Probe to 0.4 m Probe Adaptor Plate' shown in Fig. 2.11.
  - The test gas pipes are of small bore in order to prevent flue gases breathing in and out of them when the flue pressure fluctuates with load changes. To prevent blockage caused by the drop-out of contaminants from the flue gas at acid dew-point temperatures, the test gas inlet **must** be blanked off and leaktight. If the probe is to be permanently connected to the test gas supply pipework, it is **essential** to:
    - fit a high quality, corrosion resistant (stainless steel), solenoid valve, manually operated valve or non-return valve (that is leaktight even at zero back-pressure) in the pipework as close to the test gas inlet valve as possible.
    - keep the valve closed when the calibration system is not in use.
-

# 1 INTRODUCTION

The ZFG2 zirconia oxygen probe is designed to measure oxygen concentration in flue gas by an in situ ('wet analysis') method which avoids the measurement error, typically 20% higher than the actual value, introduced by the sampling system used in a 'dry analysis' method.

The system comprises a flue-mounted ZFG2 oxygen probe containing a zirconia cell and a ZDT electronics unit that provides the power and reference air supply necessary for probe operation.

The probe is safe under start-up conditions for all conventional boiler fuels and for refinery 'safe area' applications, provided the ignition temperature of the fuel is greater than 200 °C, Apparatus Group IIB is appropriate and the optional flame arrester is fitted.

These instructions must be read in conjunction with the ZDT Zirconia Oxygen Analyzer Operating Instructions (IM/ZDT).

## 1.1 Principle of Operation – Figs 1.1 and 1.2

The probe contains a sensing element, comprising a thimble-shaped zirconia cell fitted with inner and outer electrodes at its closed end. The inner electrode is exposed to the flue gas entering the open end of the cell; the outer electrode is supplied with air from a pump or regulator and is therefore exposed to a constant partial pressure of oxygen. Since zirconia is an electrolyte that conducts only oxygen ions at temperatures in excess of 600°C, the voltage generated between the electrodes (i.e. the cell output) is a function of the ratio of the oxygen partial pressure on the inner electrode and its temperature. Therefore, any change in the oxygen partial pressure of the flue gas at the exposed electrode produces a change in the cell output voltage as dictated by the Nernst equation – see Appendix A3.

Cell output voltage decreases logarithmically with increasing oxygen, thus giving high sensitivity at low oxygen levels as shown in Fig. 1.2.

A heater element, powered by the ZDT electronics unit, maintains the cell temperature at 700 °C.

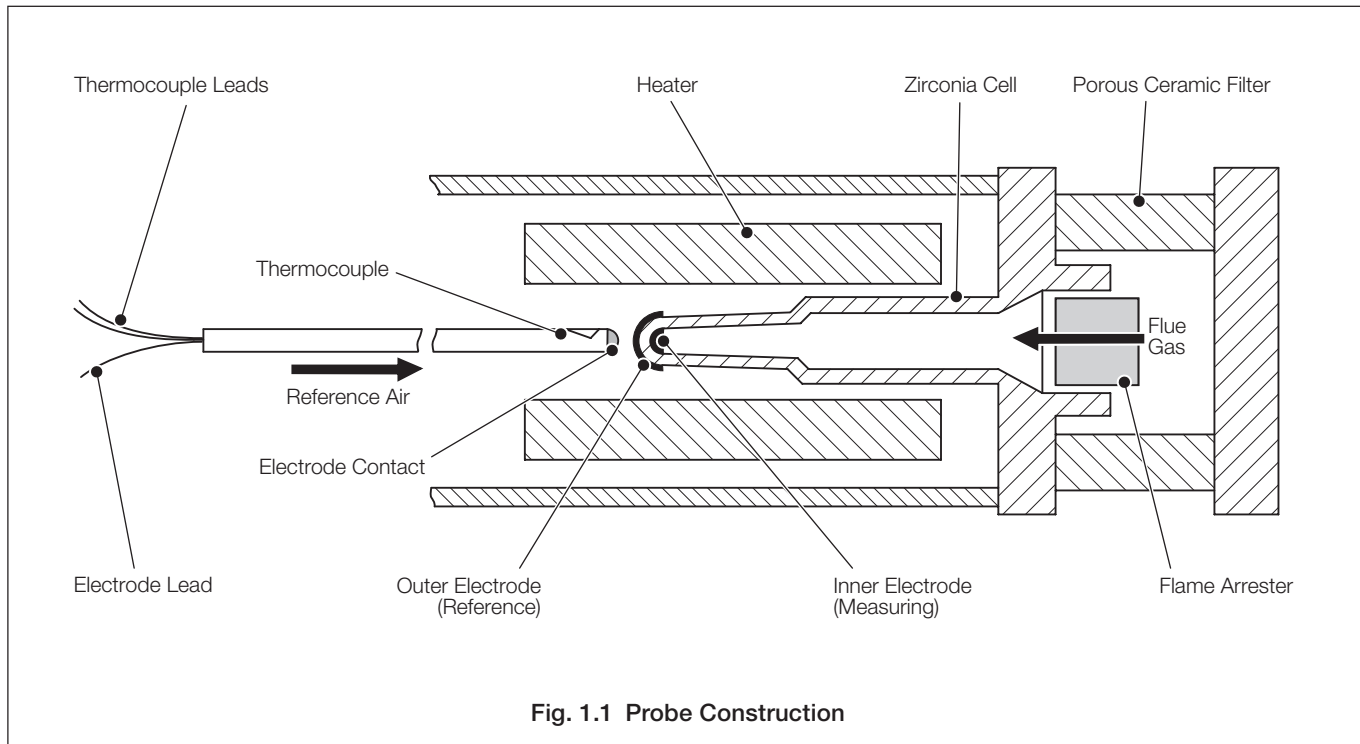

## ...1 INTRODUCTION

**Note.** The line shown is applicable only for a cell constant of zero mV at 700 °C.

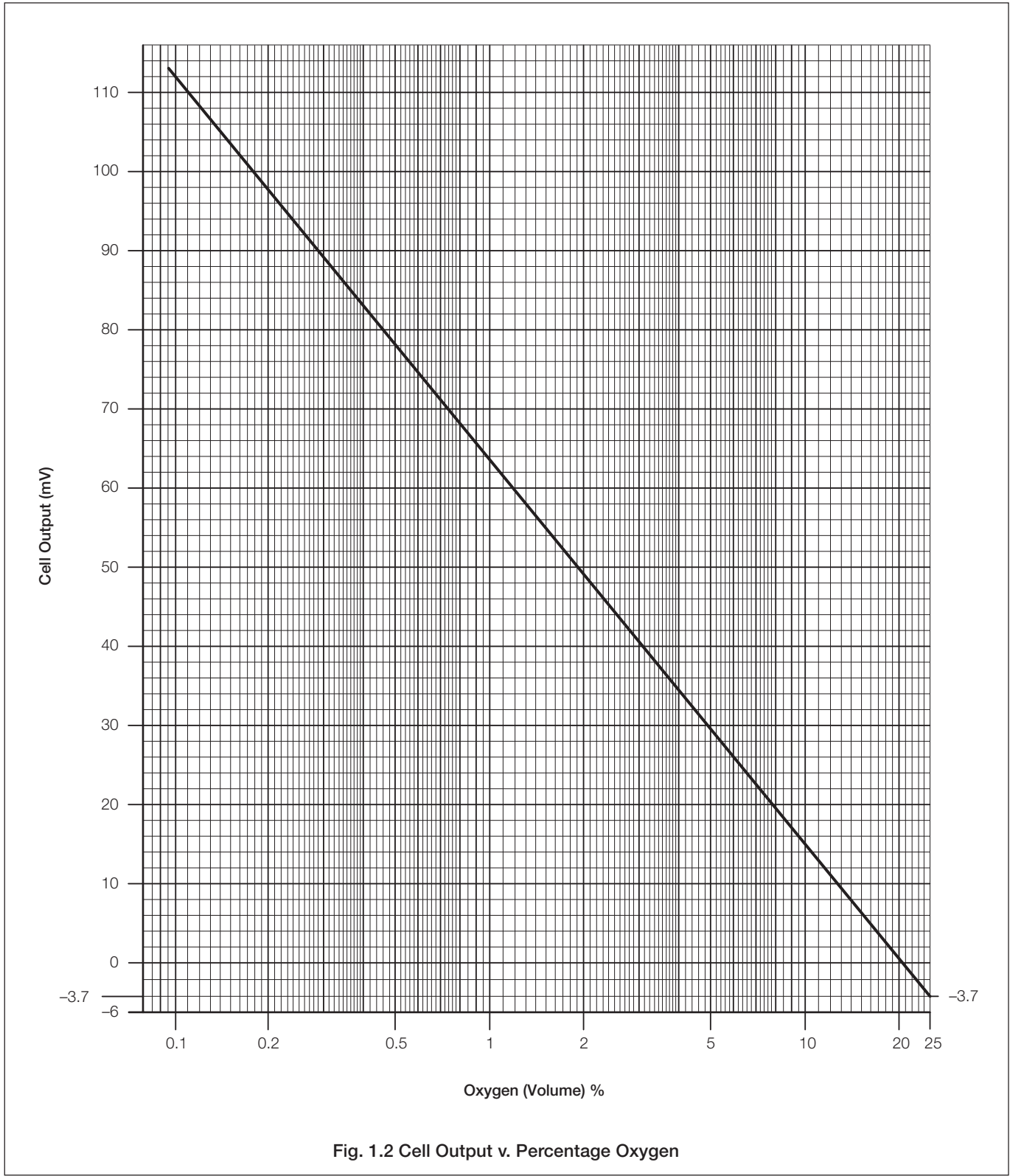

## 2 PREPARATION

### 2.1 Checking the Code Number – Fig. 2.1

Ensure that the correct probe is being installed by checking the code number against Table 2.1 below. The identification label is fitted on the probe head – see Fig. 2.1.

**Note.** The table is for identification purposes only. Not all code combinations are available.

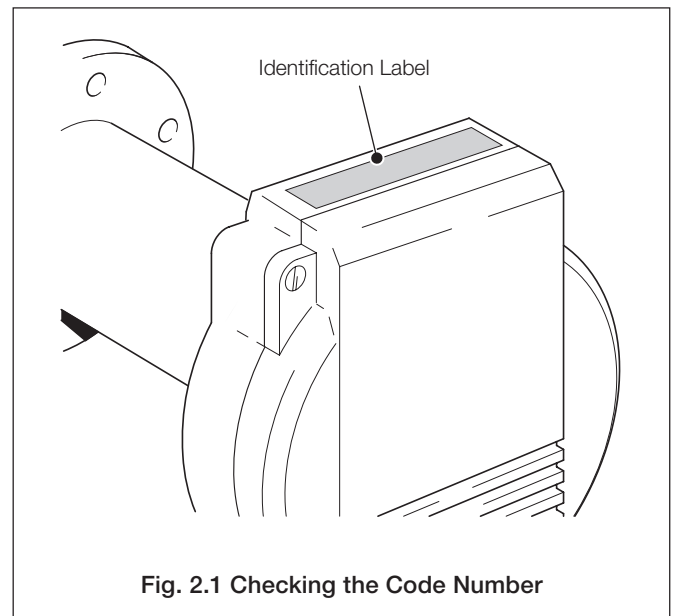

Fig. 2.1 Checking the Code Number

### 2.2 Accessories Check

#### 2.2.1 Test Gas Connector Kit

Check that the following items are supplied:  
 connector pipe (1/4 in. o.d.) with nut and 1/4 in. olive,  
 6mm olives (3) (spare alternatives),  
 spare 1/4 in. olive,  
 M4/M5 open-ended spanner.

Code Digits 1, 2, 3, 4	5	6	7	8	9	10	11	12	13
Basic Type Number	Insertion Length	Flange Type	Conduit			Cell	Flame Arrester	Reference Air	Mounting Plate Assembly
			Entry Type	No. Off	Length				
ZFG2 Zirconia Oxygen Probe	1 0.4m	1 STD	1 20mm	0 None	0 None	1 Standard Cell	0 None	1 Internal	0 None
	2 1.0m	2 DIN	2 1/2 in. NPT	1 One Std.	1 6m	2 Flow-Through Cell 3 Fast Response Cell	1 Flame Arrester	2 External	1 Standard (0.4m probes) 2 Standard (long probes)
	3 1.5m	3 ANSI		2 Two Std.	2 10m				
	4 2.0m	4 JIS		3 One IP65					
5 Model132		4 Two IP65							
	9 Special								

Table 2.1 Identification

	ZFG2	2	1	1	2	1	1	1	1	2
ZFG2 Zirconia oxygen probe										
Insertion length – 1.0m										
Flange type – standard										
Conduit entry type – 20mm										
Number of conduits – two										
Conduit length – 6m										
Cell type – standard										
Flame arrester fitted										
Internal reference air tubing (within conduit)										
Standard mounting plate										

Table 2.2 Code Number Example

## ...2 PREPARATION

### 2.2.2 Probe Flanges

(Dimensions in mm [in.])

**Note.** The flange types listed are **NOT** pressure retaining.

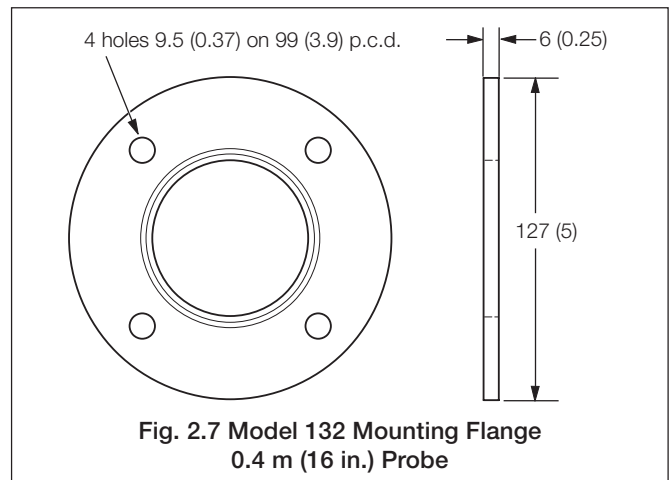
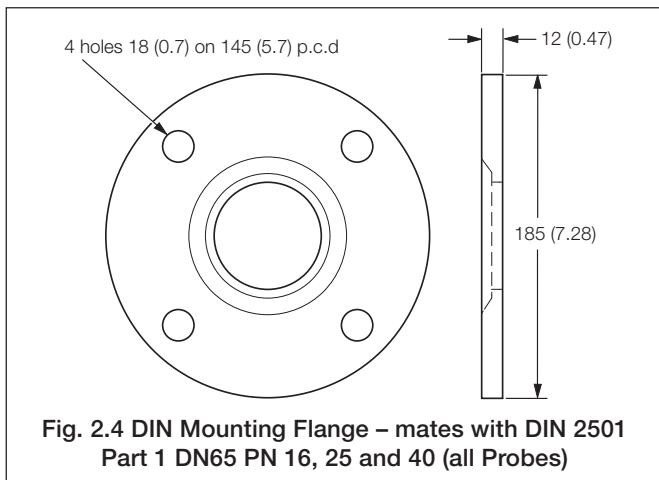
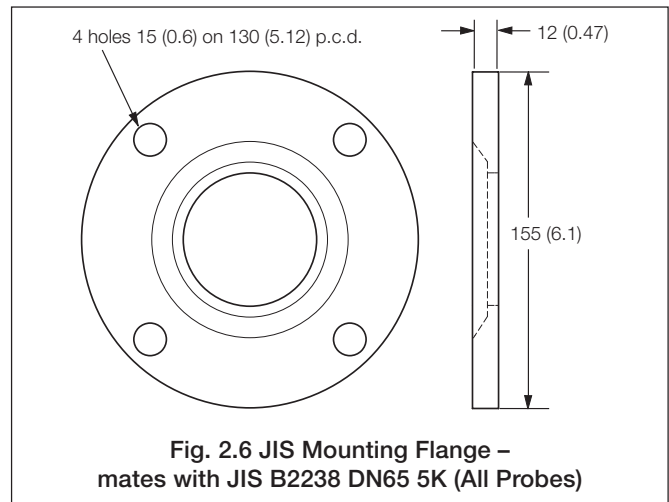
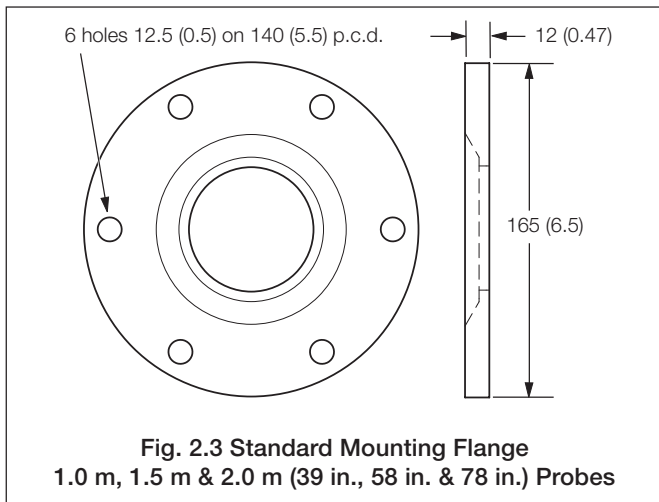
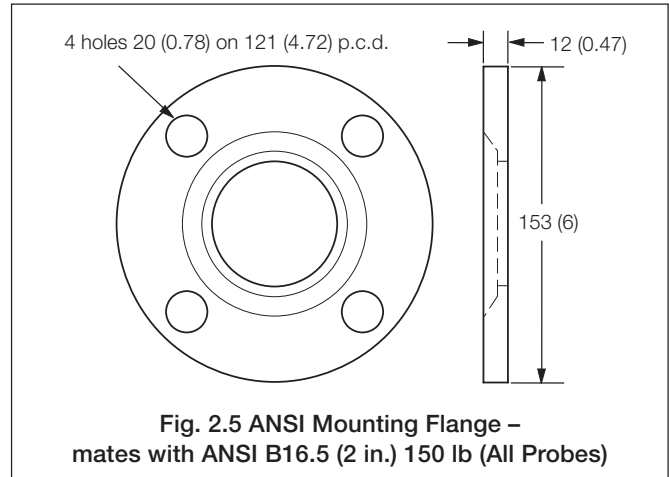
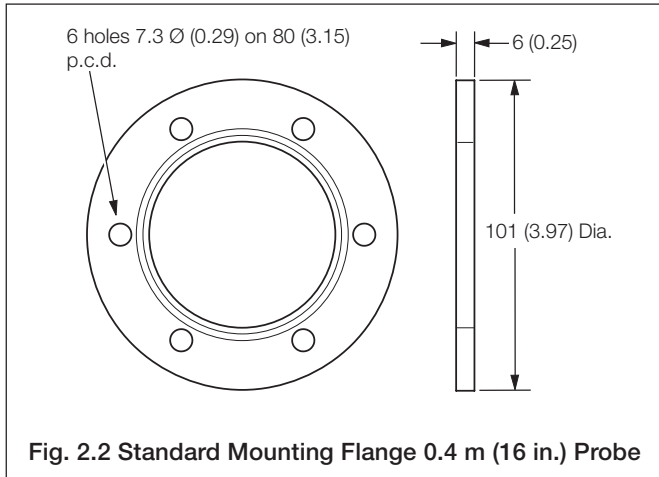

**2.2.3 Mounting Plates – Figs 2.8 and 2.9**

In addition to the probe flange, the probe may also be supplied with a mounting plate assembly if specified – see Table 2.1. A mounting plate is required if there is no existing mounting on the flue or boiler.

**0.4m probes**, including items not shown in Fig. 2.8:

- probe mounting gasket,
- M6 shakeproof washers (6),
- M6 plain washers (6),
- M6 nuts (6).

**1.0m, 1.5m and 2.0m probes**, including items not shown in Fig. 2.9:

- probe mounting gasket,
- M10 nuts (6),
- M10 washers (6).

**2.2.4 Mounting Adapters (0.4m Probes only) – Figs. 2.10 and 2.11**

Mounting adapters are available for special mounting configurations.

**2 1/2 in. NPT male bush**, including items not shown in Fig. 2.10:

- probe mounting gasket,
- M6 x 16 hexagon-head steel screws (6),
- M6 shakeproof washers (6),
- M6 plain washers (6).

**Long probe to 0.4m probe adapter**, including items not shown in Fig. 2.11:

- adapter gasket,
- Probe mounting gasket,
- M6 x 16 hexagon-head steel screws (6),
- M6 shakeproof washers (6).

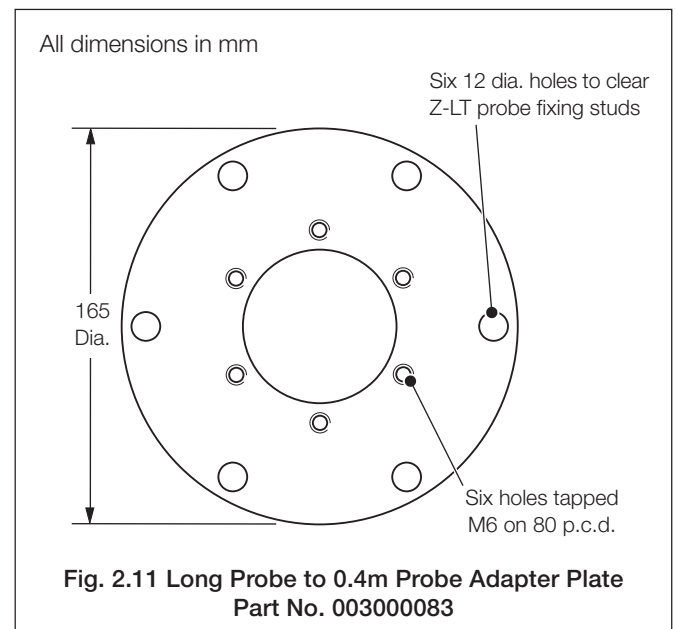
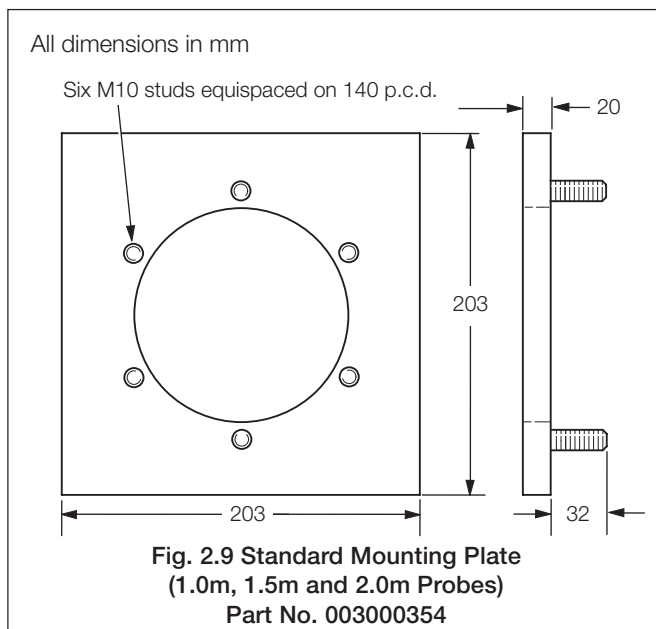
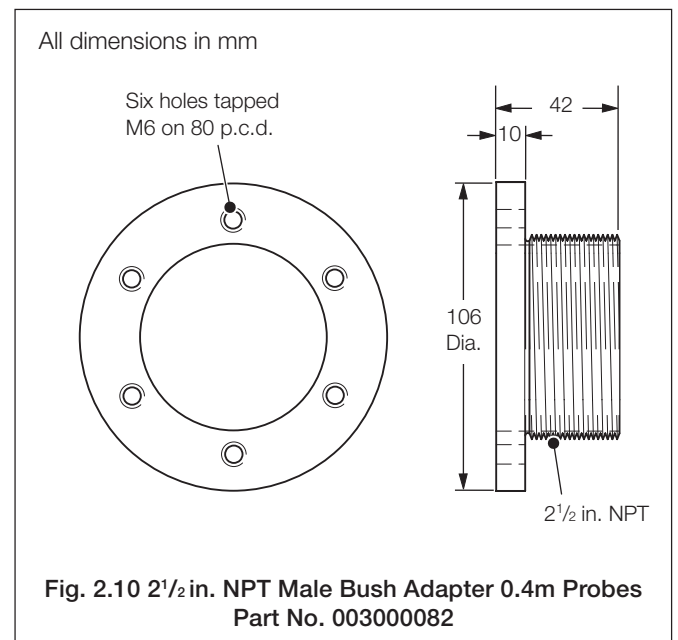
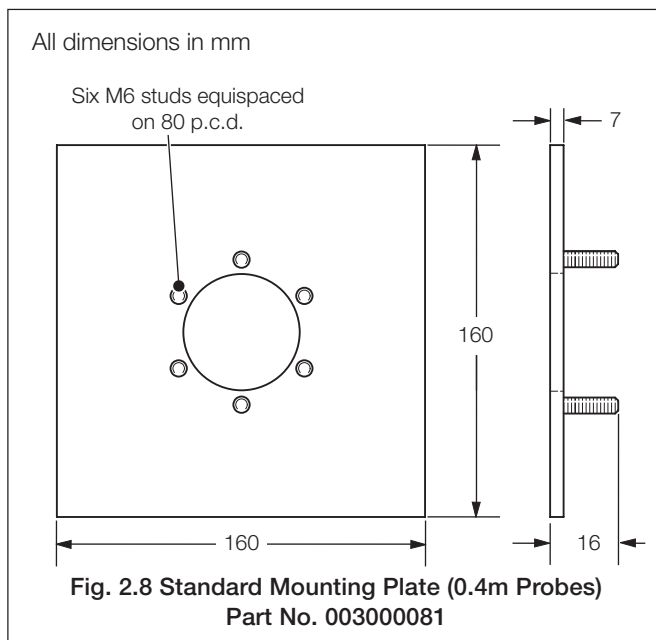

### 3 INSTALLATION

**Warning.** BEFORE INSTALLING THE PROBE, READ THE WARNINGS AND INSTALLATION NOTES ON PAGE 2.

#### 3.1 Siting

Select a position where the intake is located in the main stream of flue gas. Gas temperature must be in the range 20°C to 600°C.

Avoid positions where:

obstructions or bends create turbulence in the gas flow and/or hinder probe insertion and removal.

vibration induced by other plant or vortex shedding of the probe could result in mechanical failure of the probe.

If excessive dust flows are likely, fit a deflector plate (part no. 003000356) with its apex facing the direction of gas flow as shown in Fig 3.1. Refer to the **Note** on page 2 if a deflector plate is required for use with a 0.4 m probe.

If necessary, thermally lag the probe mounting flange and body to prevent acid dew-point corrosion and to maintain the probe head temperature within the range of -10 to +80 °C.

Probe dimensions are shown in Fig 3.2. A clearance of at least 25 mm in excess of the overall probe length is necessary for installation or removal procedures.

The probe is normally supplied with factory-fitted conduit enclosing factory-connected cable ready for connection to the ZDT electronics unit. Individual signal and power conduits are available to enable the signal and power cables to be routed separately.

Alternatively, armored power and signal cables can be supplied loose for cable runs greater than the preset conduit lengths. Extension cable can also be used to increase the separation between the probe and the electronics unit to a maximum of 100 m (328 ft.).

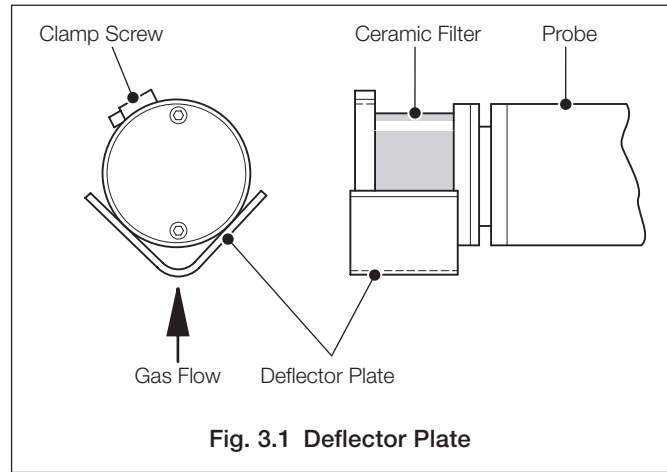

**Fig. 3.1 Deflector Plate**

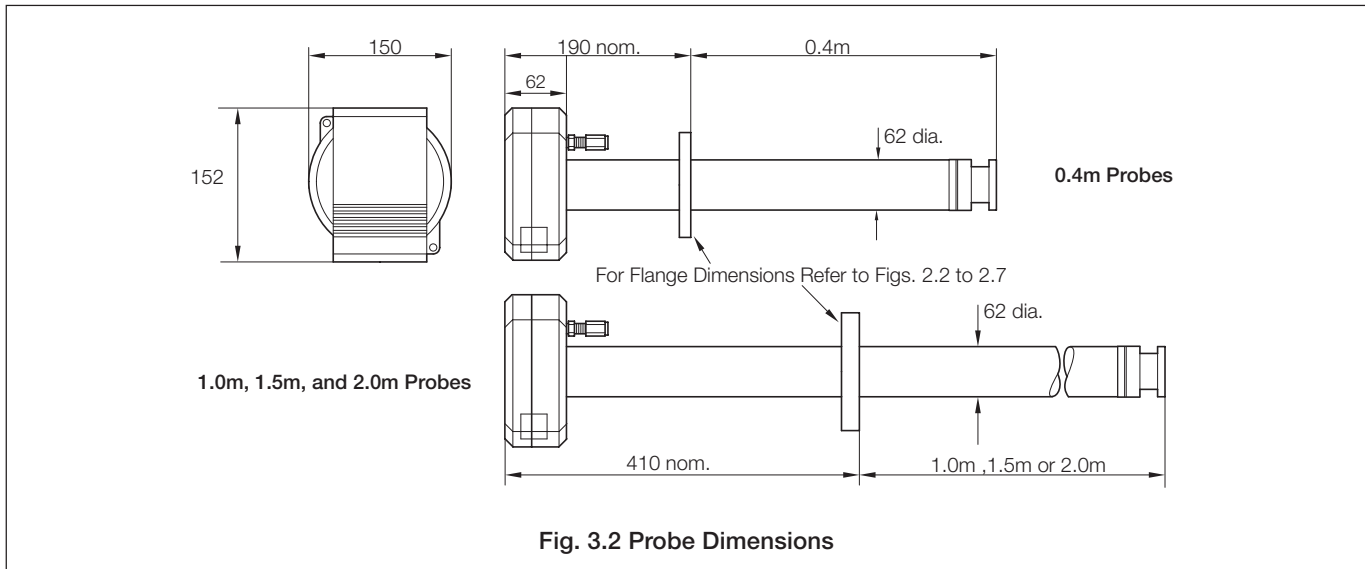

**Fig. 3.2 Probe Dimensions**

Cable/Tubing Reference	Description
Cell output cable	16/0.2 laid up red and blue twin copper braid with overall PVC sheath
Thermocouple cable	Ni Cr/Ni Al BS4937 type K and DIN IEC 584 (BS part no.4)
Heater cable	Max run 100m. Max loop impedance 2Ω
Air tubing	1/4 in o.d. x 1/8 in stainless steel, nylon or PVC tube (100°C ambient max)

**Table 3.1 Cable References and Tubing Specification**

### 3.2 Mounting

#### 3.2.1 0.4m Probe

##### (Flange 'Standard' Mounting) – Fig. 3.3

- ① Cut a 75 mm minimum diameter hole in the flue wall.
- ② Either:  
Weld the mounting plate into place, concentric with the hole in the flue.  
**or**  
Drill and bolt the plate to the flue.
- When using the latter method, fit a suitable gasket between the plate and the flue casing.
- ③ Fit the probe gasket and insert the probe into the flue.
- ④ Secure the probe and gasket using six M6 nuts and washers.

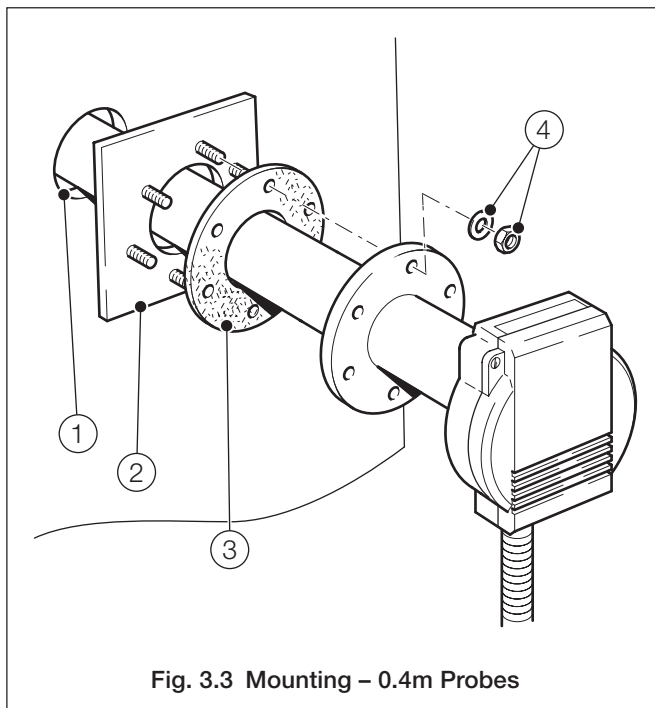

Fig. 3.3 Mounting – 0.4m Probes

#### 3.2.2 1.0m, 1.5m and 2.0m Probes – Fig. 3.4

- ① Cut a 120mm minimum diameter hole in the flue wall.
- ② Either:  
Weld the mounting plate into place, concentric with the hole in the flue.  
**or**  
Drill and bolt the plate to the flue.
- When using the latter method, fit a suitable gasket between the plate and the flue casing.
- ③ Fit the probe gasket and insert the probe into the flue.
- ④ Secure the probe and gasket using six M10 nuts and washers.

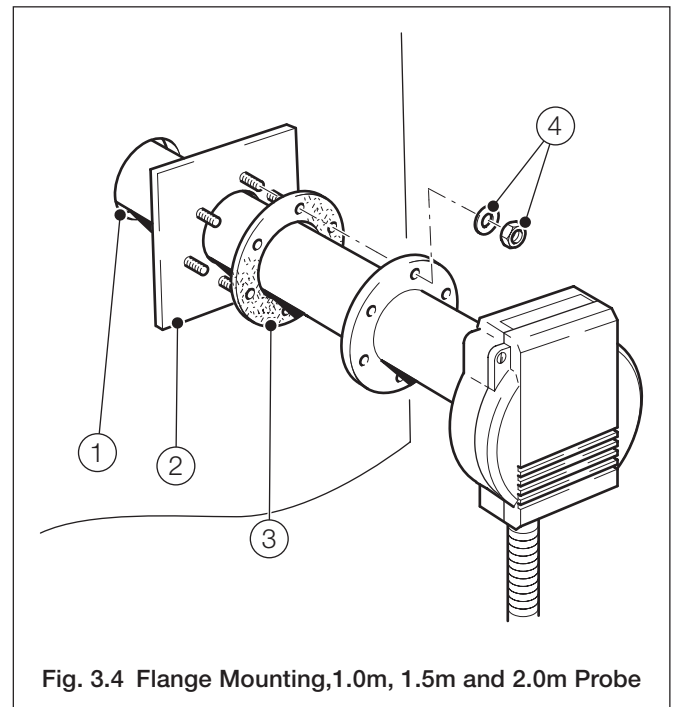

Fig. 3.4 Flange Mounting, 1.0m, 1.5m and 2.0m Probe

## ...3 INSTALLATION

### 3.2.3 0.4m Probe (2½ in. Male Bush NPT Mounting) – Fig. 3.5

**Note.** The following procedure applies where a 2½ in. NPT female fitting is already installed in the flue.

- ① Apply anti-seize compound (e.g. Rocol J166 or similar) to the thread on the male bush mounting adapter. Screw the adapter into the existing flue fitting. Tighten by inserting two M6 screws into opposite holes in the adapter and using a bar as a lever – see **Caution**.

**Caution.** Do not use the probe body as a lever to tighten the male bush.

- ② Fit the probe gasket over the probe and insert the probe through the adapter into the flue.
- ③ Secure the probe and gasket using six M6 screws and washers.

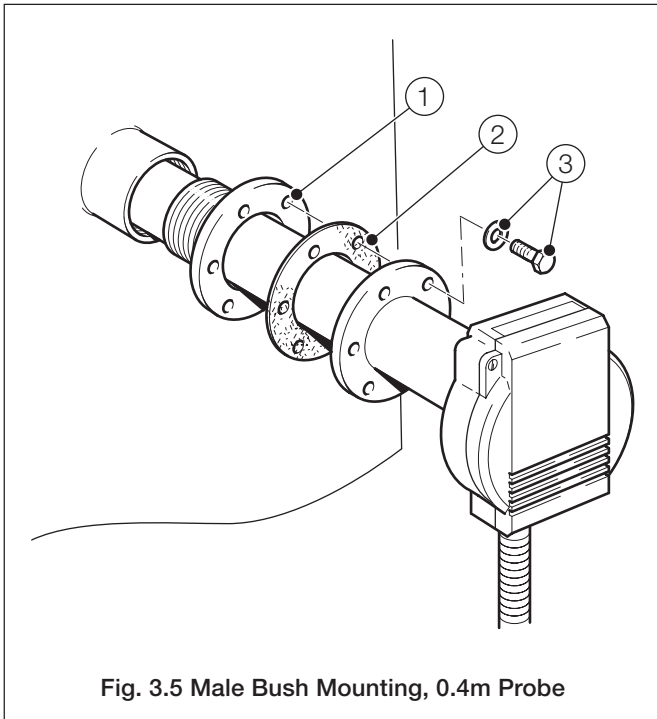

### 3.2.4 0.4m Probe (Z-LT Adapter Plate Mounting) – Fig. 3.6

**Note.** The following procedure applies where an existing Z-LT or long ZFG installation is to be replaced by a 0.4 m ZFG2 probe.

- ① Locate the Z-LT adapter gasket on the existing Z-LT mounting plate.
- ② Locate the Z-LT adapter plate on the gasket.
- ③ Secure the gasket and plate with six M10 nuts and washers.
- ④ Fit the probe gasket over the probe end. Insert the probe into the flue.
- ⑤ Secure the probe and gasket using six M6 screws and washers.

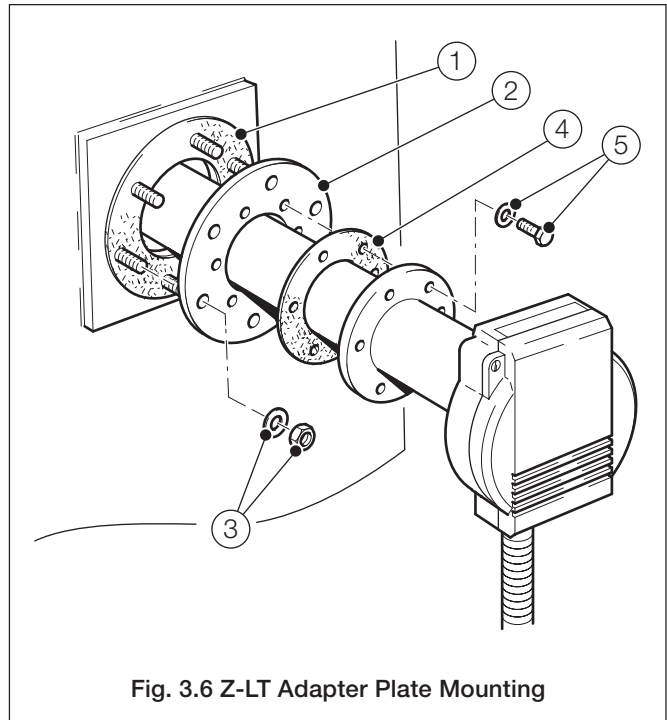

## 4 CONNECTIONS

### 4.1 Conduit and Cable Details

A schematic diagram is given in Section 5 of the ZDT Operating Instructions (IM/ZDT). For cable and reference air tubing details refer also to Table 3.1 on page 8.

### 4.2 Probe Connections – General

The probe is usually supplied ready-fitted with 1 or 2 flexible conduits containing the cable and internal reference air tubing (if applicable) and no connections to the probe head are required.

For probes supplied without cables and conduit(s), refer to Sections 4.2.1 and 4.2.2 and connect the cables and fit the conduit(s). A 6 mm external earth (ground) bonding point is provided on the back of the probe head – see Fig. 4.5.

For electronics unit connections refer to the ZDT Operating Instructions IM/ZDT.

#### 4.2.1 Accessing Probe Terminals – Fig. 4.1

- ① Slacken the two captive M4 screws retaining the head cover and remove the cover.
- ② Pull off the test gas tube ('TEST GAS').
- ③ Pull off the reference air tube ('REF. AIR').
- ④ Slacken the 2 x M4 captive screws retaining the connections cover and remove the cover – see **Caution**.

---

**Caution.** Do not damage the four-bore insulator protruding from the centre of the probe head.

---

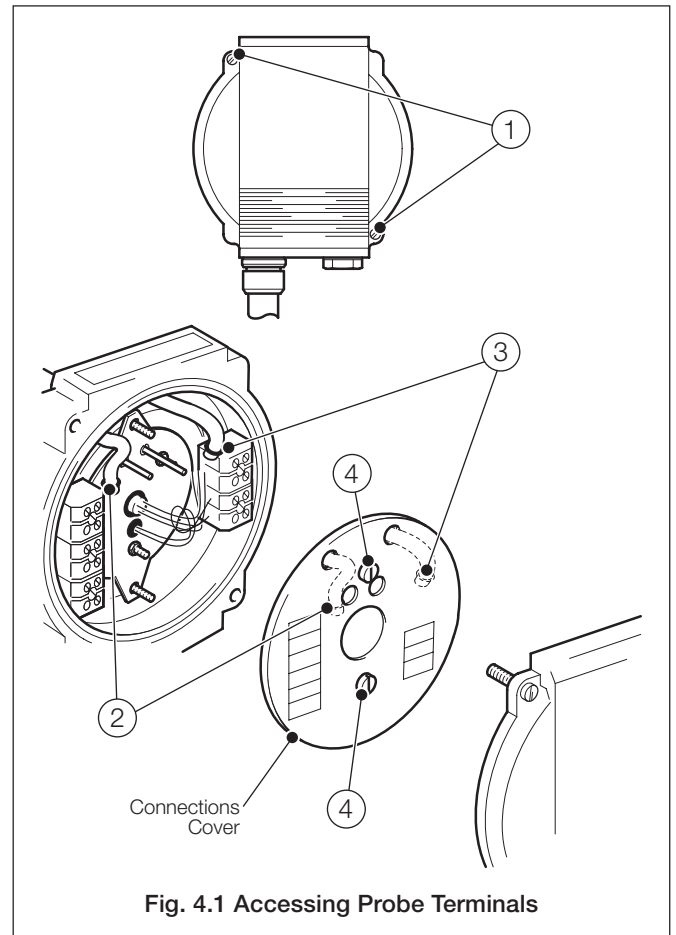
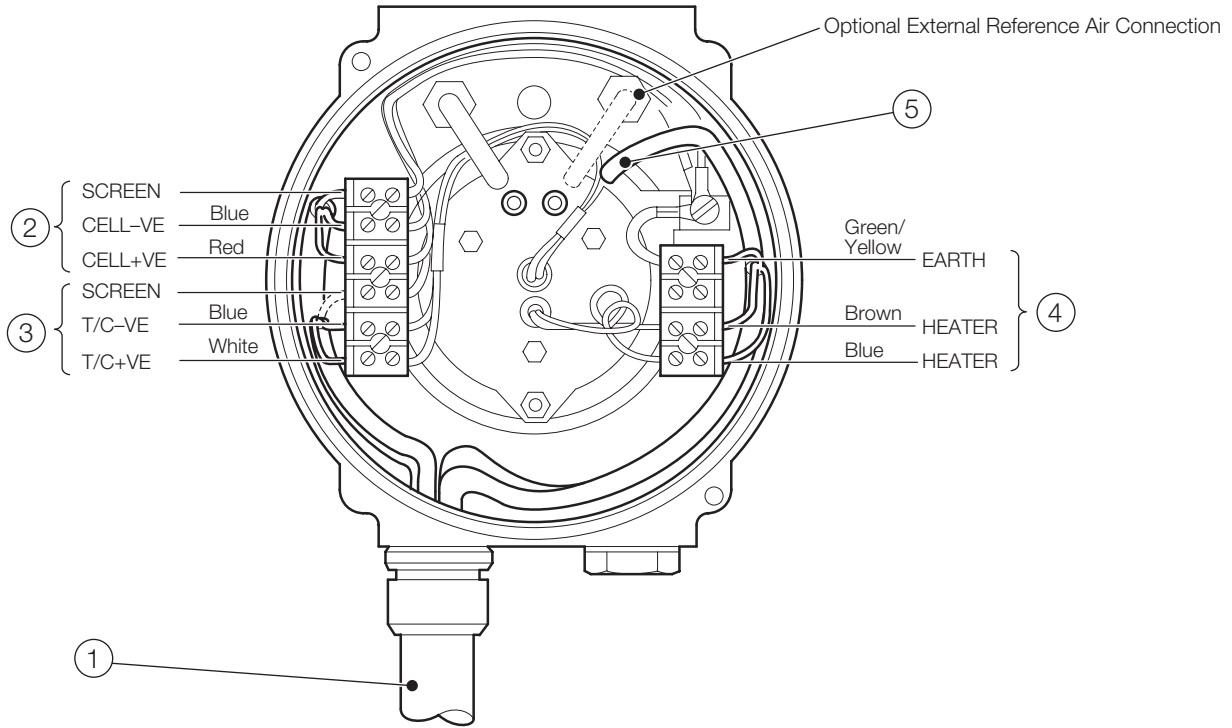
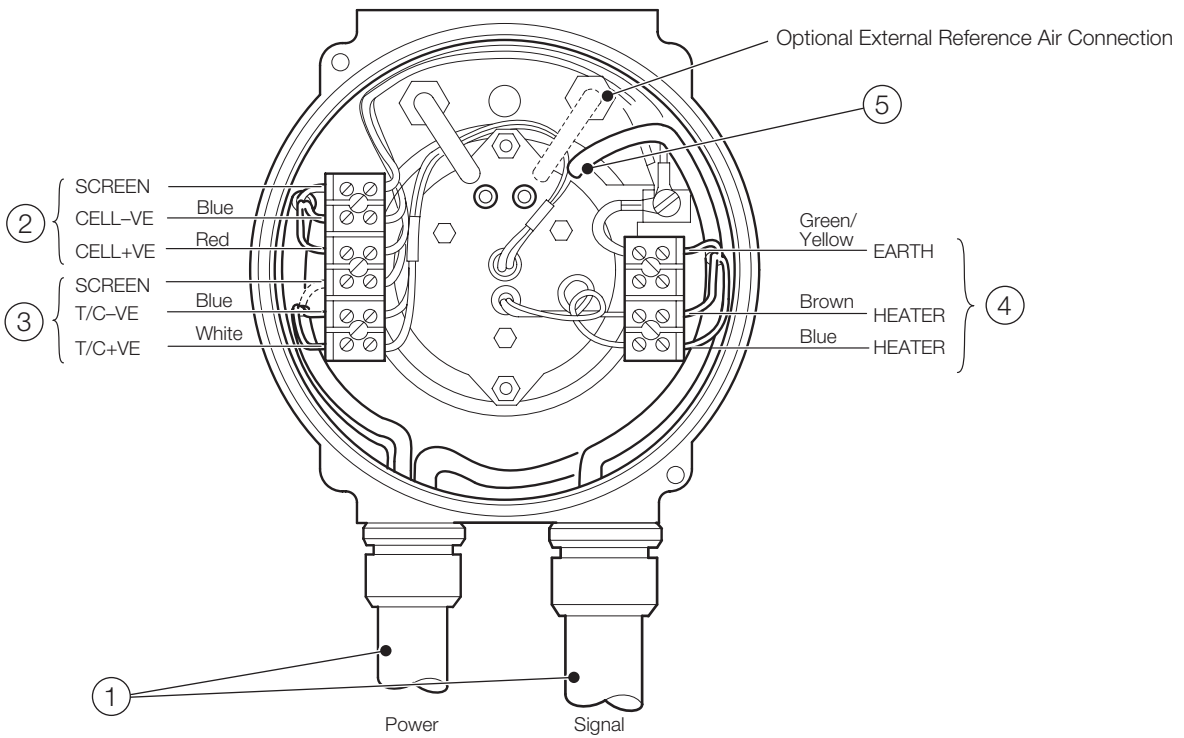

Fig. 4.1 Accessing Probe Terminals

4.2.2 Probe Connections – Figs. 4.2 and Fig. 4.3



A – Single Conduit (Power and Signal Cables)



B – Double Conduit

Fig. 4.2 Probe Connections

**...4.2.2 Probe Connections – Figs. 4.2 and Fig. 4.3**

When making connections, ensure that the cables and reference air tubing are routed correctly as shown in Fig. 4.2A (single conduit) or Fig. 4.2B (double conduit).

- ① Fit suitable cable gland(s) or conduit fitting(s) into the head (1/2 in. NPT or 20mm as applicable).
- ② Make cell connections:
 

Red	– 'CELL +VE'
Blue	– 'CELL -VE'
Screen	– 'SCREEN'.
- ③ Make thermocouple connections:
 

White	– 'T/C +VE'
Blue	– 'T/C -VE'
Screen*	– 'SCREEN'. * If applicable.
- ④ Make heater connections:
 

Brown*	– 'HEATER'
Blue*	– 'HEATER' *polarity unimportant.
Green/Yellow	– 'EARTH'.
- ⑤ **Internal reference air connection only** – route the reference air tubing as shown but do not connect yet.

**Note.** For external reference air connection refer to Section 4.3.1.

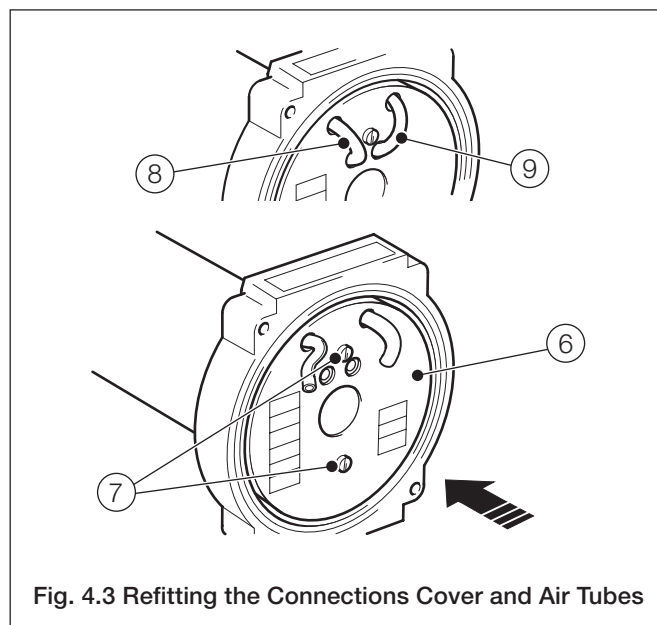

**Fig. 4.3 Refitting the Connections Cover and Air Tubes**

Referring to Fig. 4.3:

- ⑥ Replace the connections cover, ensuring that the test gas and reference air tubes are threaded through the correct holes in the cover.
- ⑦ Secure the cover with the two M4 captive screws.
- ⑧ Connect the test gas tube ('TEST GAS').
- ⑨ Connect the reference air tube ('REF. AIR').

Refit the head cover (reversing step ① in Section 4.2.1).

### 4.3 Pipe Connections – Fig. 4.4

The compression fittings on the back of the probe head have a 1/4 in. olive as standard. 6 mm olives are supplied in the accessory kit, if required – see Section 2.2.

#### 4.3.1 External Reference Air Connection – Fig. 4.4B

A clean, dry, oil-free air supply is required, e.g. from a pump or regulator unit (refer to Section 10.4). Connect the reference air tubing to the external reference air inlet – see Fig. 4.4B. For internal reference air connection (enclosed in probe conduit) refer to Section 4.2.2, step ⑤.

---

**Important Note.** The reference air supply **must** be to instrument air standards – i.e. it **must** be dry and free of oil and particle contamination.

---

#### 4.3.2 Vent Connection – Fig. 4.4

The vent allows the reference air to escape to atmosphere. If the vent is likely to be exposed to moisture, a suitable tube must be connected to the vent and routed to a dry area. Ensure that the vent, or the vent tube, does not become blocked during probe use.

#### 4.3.3 Test Gas Inlet Connection – Fig. 4.4

A test gas inlet is provided for in situ probe testing using a test gas. A test gas connector kit is supplied in the accessory kit. Read the Installation Notes on page 2 and refer to Section 7.1 for test gas use.

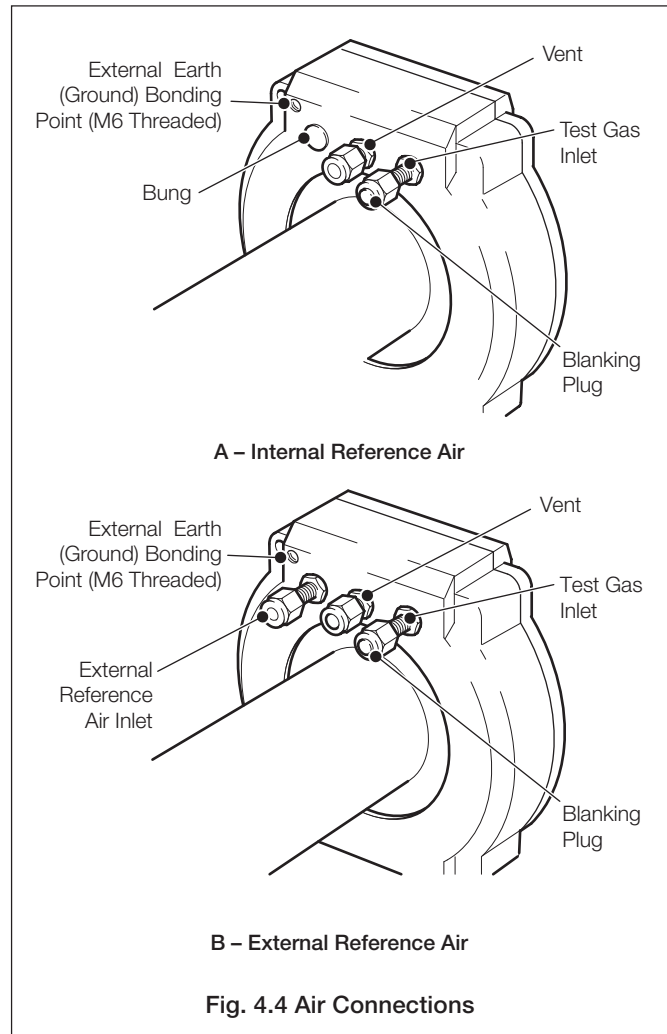

---

## 5 OPERATION

---

### 5.1 Preparation

- a) If the probe **is not** permanently connected to test gas pipework for automatic calibration purposes, ensure that a blanking plug is securely fitted to the test gas inlet connection on the probe – see Fig. 4.5.
- b) If the probe **is** permanently connected to test gas pipework for automatic calibration purposes, ensure that the valve installed in the pipework adjacent to the test gas connection (see Installation Notes on page 2) is closed.

---

**Note.** If the test gas connection is not sealed, air leaking into the probe via the connection will cause measurement errors. In a pressurized flue, gases venting to atmosphere through the connection will cause corrosion of, and/or block, the test gas tube. In a negative pressure flue, air leakage will cause high O<sub>2</sub> reading errors.

---

- c) Check the connections on both the probe and the electronics unit (refer also to the ZDT Operating Instructions *IM/ZDT*).
- d) Adjust the reference air flow to a stable flow rate between 100 and 1,000 cc/min.

---

## 6 CALIBRATION

---

Full gas calibration procedures for the system are detailed in the ZDT Operating Instructions (*IM/ZDT*).

---

**Important Note.** Test gas air flows for all ZFG2 probes must be set to 3 litres (3000 cc) per minute ( $\pm 10\%$ ) or measurement errors will occur.

---

---

## 7 FAULT FINDING

---

System fault finding procedures are detailed in the ZDT Operating Instructions, *IM/ZDT*. Where a fault is traced to the probe, it may be possible to identify and rectify the fault. After any rectification, the system must be recalibrated as detailed in *IM/ZDT* to maintain the stated accuracies.

### 7.1 In Situ Probe Testing

Equipment required:

- Digital Multimeter (10 M $\Omega$  input impedance on mV ranges),
- Earth continuity tester,
- Zero test gas (within the range 10 to 21% O<sub>2</sub> in N<sub>2</sub>),
- Span test gas (within the range 1 to 10 % O<sub>2</sub> in N<sub>2</sub>).

Ensure that the flue temperature is within the limits 20 to 600 °C and allow a 30 minute warm-up period for the instrument.

- a) Remove the blanking plug from the test gas inlet and fit the pipe, nut and olive from the connector kit to the inlet – see Fig. 4.5.
- b) Connect the test gas using flexible tubing to suit the outside diameter of the pipe (6 mm or 1/4 in. i.d.).
- c) Apply the test gas at a rate of 3 litres per minute and allow 5 minutes for the instrument reading to settle.

If the analyzer response is normal when measuring test gas but sluggish and insensitive when measuring flue gas, replace the ceramic filter as described in Section 8.2.

---

**Note.** Check that the air supply tube has not become disconnected inside the probe head – see Sections 4.2.1 and 4.2.2.

---

If correct test gas response cannot be obtained, measure the cell output voltage detailed in steps d) and e).

- d) With the test gas connected remove the leads to the 'Input' terminals on the ZDT Unit and connect the digital multimeter (0 to 200 mV range) directly across the leads.
- e) The measured voltage should correspond generally to the oxygen volume percentage for the test gas used – see the graph in Fig. 1.2 on page 4. Slight differences result if the probe's cell constant is not zero mV.

If there is a difference of more than  $\pm 5$  mV between the measured cell output voltage and the graph, check the probe heater temperature by measuring the thermocouple voltage as described in steps f) and g).

- f) Using either a mercury or digital type thermometer, measure the ambient temperature at the terminals marked 'Probe T/C' on the electronics unit – see Section 5.4.1 in the ZDT operating instructions *IM/ZDT*.
- g) Measure the voltage across the 'Probe T/C' terminals on the

## ...7 FAULT FINDING

### ...7.1 In Situ Probe Testing

Table 7.1 gives the voltages which should be present at the 'Probe T/C' terminals (step g), according to the temperature measured at step f), when the probe temperature has stabilized at 700 °C.

Ambient Temp. (°C)	Millivolts	Ambient Temp. (°C)	Millivolts
50	27.106	25	28.128
49	27.147	24	28.168
48	27.188	23	28.209
47	27.229	22	28.249
46	27.27	21	28.29
45	27.311	20	28.33
44	27.352	19	28.37
43	27.394	18	28.41
42	27.435	17	28.451
41	27.476	16	28.491
40	27.527	15	28.531
39	27.558	14	28.571
38	27.599	13	28.611
37	27.639	12	28.651
36	27.68	11	28.691
35	27.721	10	28.731
34	27.762	9	28.771
33	28.803	8	28.811
32	28.843	7	28.851
31	28.884	6	28.89
30	27.925	5	28.93
29	27.966	4	28.97
28	28.006	3	29.009
27	28.047	2	29.049
26	28.087	1	29.089
		0	29.128

**Table 7.1 Thermocouple v. Ambient Temperature for a Probe Temperature of 700 °C**

If the thermocouple voltage is correct, remove the probe from the flue and replace the cell and/or the electrode lead assembly – see Sections 8.3 and 8.6 (0.4 m probes) or 8.10 (other probes).

If there is no thermocouple voltage proceed to step h).

If the thermocouple voltage is low proceed to step i).

If the thermocouple voltage is high, relocate the probe to a position where the flue temperature is 600 °C or lower.

h) Disconnect the thermocouple leads from the 'TC' terminals and check the thermocouple for open- or short-circuit.

---

**Note.** A short circuit usually indicates a wiring fault rather than a faulty thermocouple.

---

If the thermocouple appears to be faulty the thermocouple/ electrode lead assembly must be replaced as described in Section 8.6 (0.4 m probes) or Section 8.10 (other probes). If the thermocouple appears to be in order continue from step i).

i) Switch off the AC supply, disconnect the heater 'H' leads from their terminals on the ZDT Unit, and measure the resistance across these leads at the probe terminal head and at the cable ends.

The correct heater resistance is 28 to 31Ω for 0.4 m probes and 26 to 29 Ω for 1.0 m, 1.5 m and 2.0 m probes.

If the resistance is incorrect, check the heater wiring and, if necessary, replace the heater assembly as described in Section 8.8 (0.4m probes) or 8.13 (other probes).

### 7.2 Bench Testing

When the fault has been rectified, the probe must be bench tested before fitting into the flue.

- Connect the probe heater and thermocouple cables to the electronics unit.
- Connect the reference air supply tube .
- Connect a digital voltmeter directly across the cell output leads after removing them from the 'PROBE CELL' terminals on the ZDT Unit.

Allow the probe to operate in air for about 20 minutes in order to achieve temperature stability.

Periodically check the reading on the digital voltmeter after the initial temperature stabilizing time has expired.

The reading should settle at the cell constant of typically 0V ±2 mV for a new cell.

When the cell attains its constant (typically after 1 hour), apply a test gas and measure the cell output as described in Section 7.1, steps and a) to d). Otherwise, the tests detailed in Section 7.1 must be carried out whilst the probe is still on the bench.

---

**Note.** The cell can take up to three hours to settle fully at its constant.

---

If the cell responds correctly to the test gas the probe can be refitted into the flue. For full probe calibration details refer to the ZDT operating instructions, *IM/ZDT*.

## 8 DISMANTLING AND REASSEMBLY

Before dismantling the probe, thoroughly clean the outer surfaces with non-abrasive materials to prevent contamination of the inner assemblies.

### 8.1 Tools Required

M3 open ended spanner,  
M4 open ended spanner (supplied),  
0 to 5 Nm torque driver fitted with a hexagon (Allen) M4,  
wrench, or alternatively, M4 Allen key,  
Small, flat-bladed (terminal) screwdriver,  
Medium, flat-bladed screwdriver.

### 8.2 Replacing the Ceramic Filter (all Probes) – Fig. 8.1

- ① Remove the two socket-head screws retaining the filter clamping plate and remove the plate and gaskets.
- ② Remove the filter and the gasket(s) between the filter and the cell mount. Discard the old filter.

When reassembling, insert a sufficient number of gaskets to allow the securing screws to hold the filter firmly in position.

**Note.** Fit a minimum of two gaskets on the cell side of the filter and a minimum of one on the end plate side. The central hole in the filter gaskets is enlarged to allow free flow of test gas past the gaskets. Ensure that the gaskets are positioned concentric with the filter to prevent any test gas flow restriction.

Tighten the screws evenly to a torque of 2 Nm.

**Caution. Do Not** over-tighten the screws. This will cause the filter to break at the probe's working temperature.

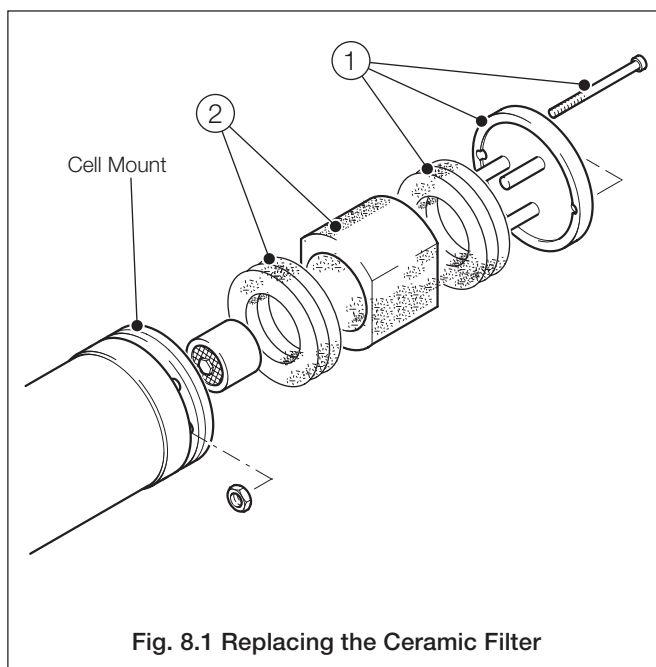

### 8.3 Removing the Zirconia Cell (all Probes) – Fig. 8.2

Remove the filter as described in Section 8.2.

- ① Carefully withdraw the flame arrester, if fitted, from the cell mount.
- ② Remove the four socket-head screws from the flange on the cell mount.

**Note.** The four screws are secured by nuts located in a groove at the end of the probe body. If the bolts have corroded and are difficult to release, carefully remove the nuts with a hacksaw.

- ③ Gently ease the cell and mount from the probe body without excessive twisting (2 to 3 mm max.).

**Caution.** During prolonged service the cell tip may become welded to the helical contact on the end of the thermocouple/electrode lead assembly, thus preventing removal of the cell. If, when removing the cell mount, all of the spring movement is taken up and resistance is felt, do not force removal or the inner electrode will be damaged. Re-insert the cell mount and refer to Appendix A1.

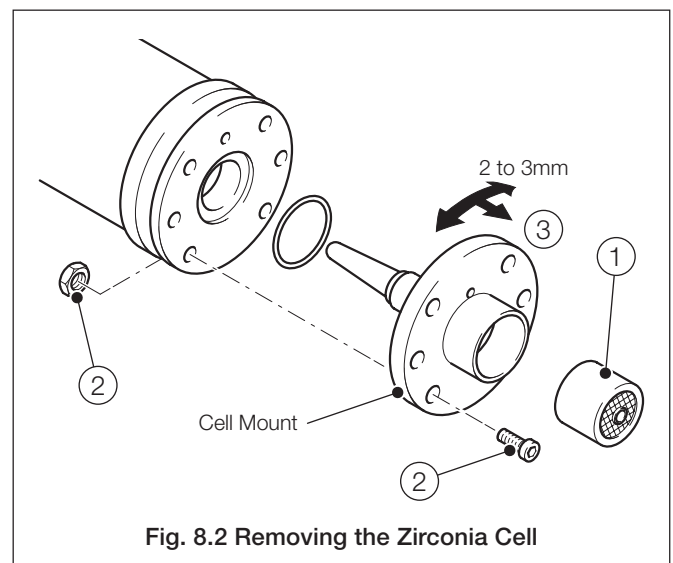

**8.4 Fitting the Zirconia Cell (all Probes) – Fig. 8.3**

- ① Examine the contact on the inner electrode insulator. The connection must appear as a flat helix, supported centrally on the insulator, when viewed through the hole at the end of the probe body.
- ② Thoroughly clean the end of the probe body, in particular the 'O' ring recess and the central hole, using a dry lint-free cloth only. Unless the 'O' ring is scratched or damaged, do not attempt to remove it for cleaning.

---

**Note.** Fit a new 'O' ring if:  
 the probe is used in temperatures exceeding 400 °C  
**or**  
 the probe is operating under positive flue gas pressure.

---

If the replacement cell/cell mount is scratched, unclean or damaged it must not be used as the flame arresting properties of the probe will be impaired.

- ③ Align the blind hole in the cell mount with the small counterbored hole in the end of the probe body. If the holes are not correctly aligned, the in situ test gas facility cannot be used.
- ④ **Gently** lead the cell into the cell body until the spring resistance from the internal electrode is felt. If there is some difficulty in locating the cell, do not force it as it may be obstructed by the heater. Use self-adhesive tape to temporarily hold the cell mount in place.

---

**Note.** If the heater is obstructing cell insertion, re-align the heater assembly as detailed in Section 8.15, step ⑤.

---

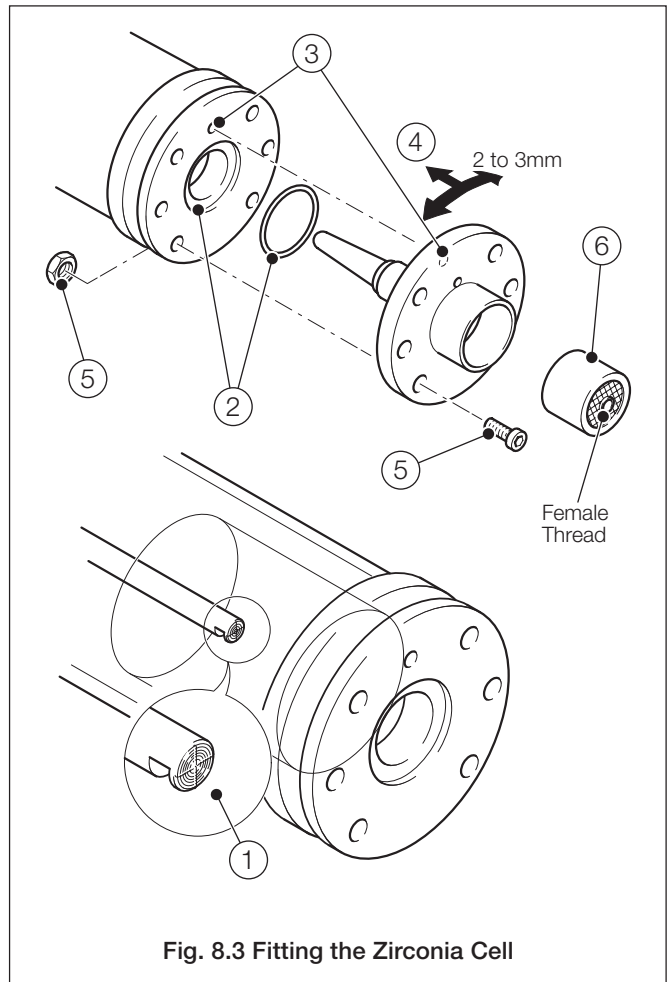

Referring to Fig. 8.3:

- ⑤ Refit the four socket head bolts and tighten to a torque of 4 Nm.
- ⑥ Replace the flame arrester (if applicable) with the female thread outermost.

Refit the ceramic filter as described in Section 8.2.

### 8.5 Removing the Inner Assembly (all Probes) – Fig. 8.4

- a) Remove the ceramic filter as described in Section 8.2.
- b) Remove the zirconia cell as detailed in Section 8.3.
- c) Gain access to the probe terminals as detailed in Section 4.2.1.

Referring to Fig. 8.4:

- ① Disconnect the heater leads (translucent insulation on 0.4 m probes or brown and blue on 1.0 m, 1.5 m and 2.0 m probes).
- ② Disconnect the thermocouple and electrode leads (red, blue and white insulation).
- ③ Remove the two M4 pillars and shakeproof washers securing the inner assembly and retain.
- ④ Carefully withdraw the inner assembly from the probe body.

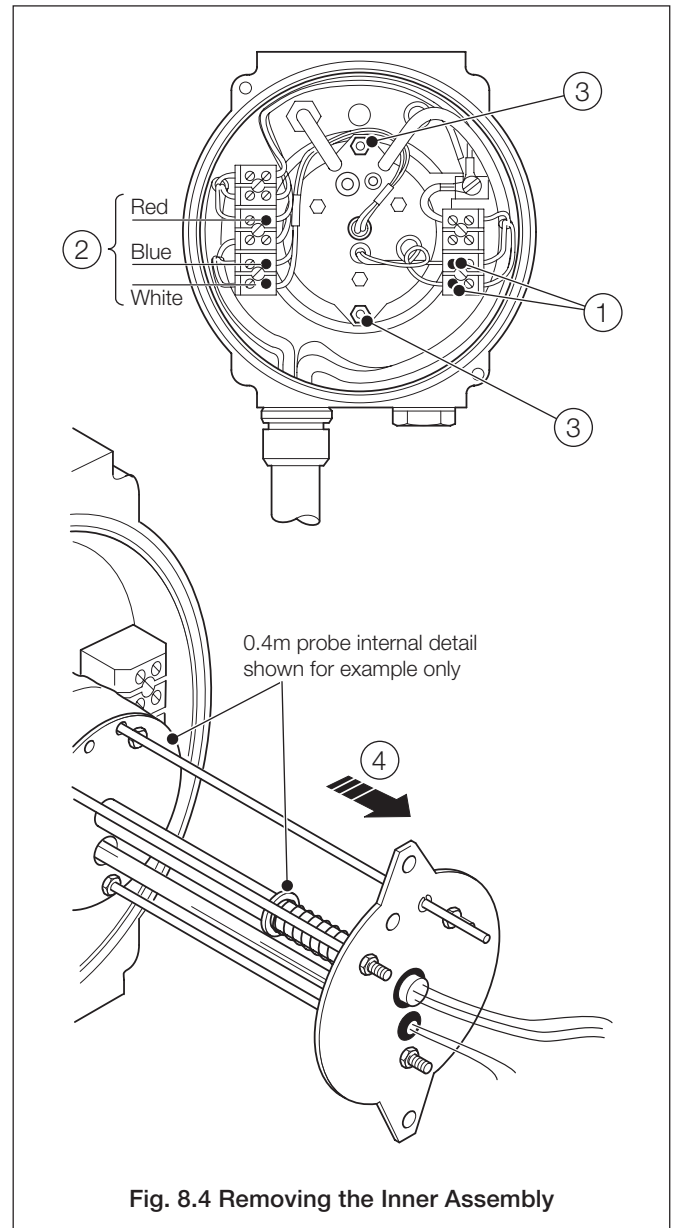

### 8.6 Removing the Thermocouple/Electrode Lead Assembly (0.4m Probes) – Fig. 8.5

Remove the inner assembly as detailed in Section 8.5.

**Caution.** The thermocouple/electrode lead assembly is fragile. Take extreme care not to damage the assembly during dismantling and reassembly.

Referring to Fig. 8.5:

- ① Remove the rubber 'O' ring from the electrode insulator and allow the thermocouple/electrode assembly to slide through the inner assembly mounting plate under spring pressure.
- ② Slide the thermocouple/electrode lead assembly towards the heater.
- ③ Pull the electrode leads through the mounting plate (from the underside of the plate).
- ④ Remove the spring, washer and rubber 'O' ring from electrode assembly and retain.
- ⑤ Slide the thermocouple/electrode lead assembly through the baffle plates and withdraw from the heater end.

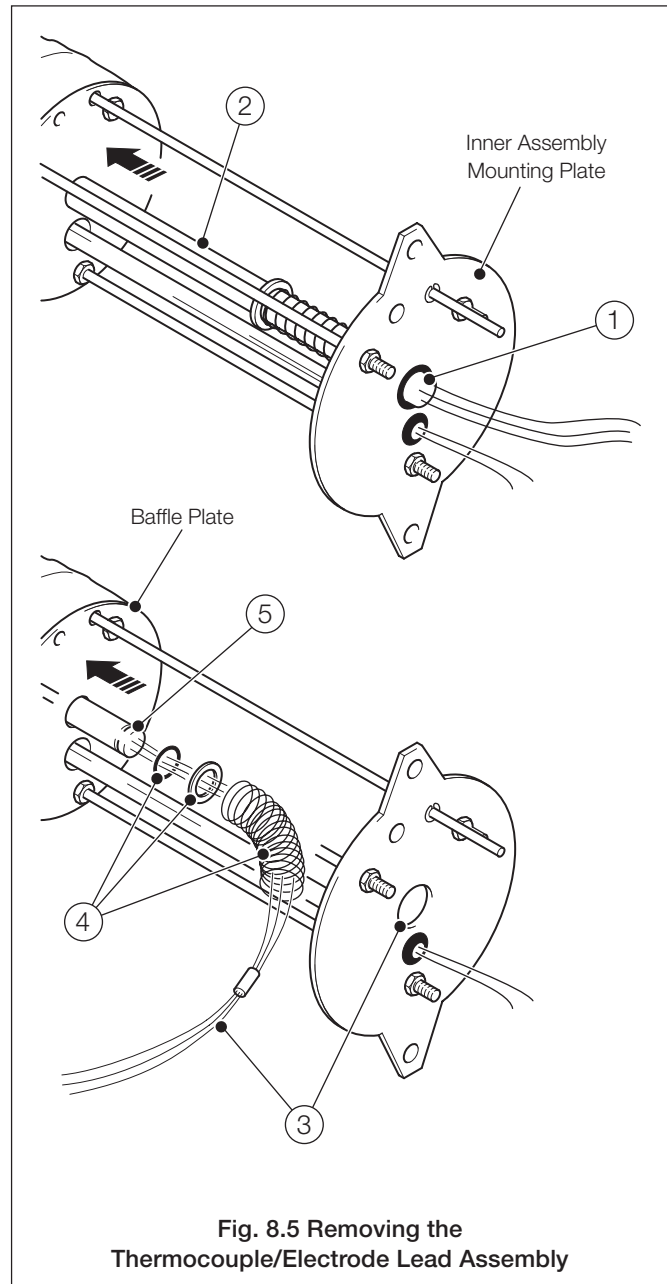

Fig. 8.5 Removing the Thermocouple/Electrode Lead Assembly

### 8.7 Fitting the Thermocouple/Electrode Lead Assembly (0.4m Probes) – Fig. 8.6

- ① Check that the thermocouple bead is located at the **electrode end** of its cut-out, i.e. butted up against the end of the cut-out.
- ② Slide the thermocouple/electrode lead assembly through the central holes in the mounting plate, baffle plates and heater.
- ③ Pull the electrode leads through the mounting plate (from the underside of the plate).
- ④ Thread the rubber 'O' ring, washer and spring over the lead ends and onto the thermocouple/electrode lead assembly (locate the 'O' ring in the second groove on the assembly).

**Caution.** Take care not to break the ceramic insulator (nearest the head) when fitting the rubber 'O' ring.

- ⑤ Thread the electrode leads back through the central hole in the mounting plate.
- ⑥ Slide the thermocouple/electrode lead assembly through the mounting plate, against the spring pressure, and secure with the rubber 'O' ring. Do not pull on the wires as this may disturb the location of the thermocouple bead (see step ①), resulting in low O<sub>2</sub> readings.

**Caution.** Take care not to break the ceramic insulator (nearest the head) when fitting the rubber 'O' ring.

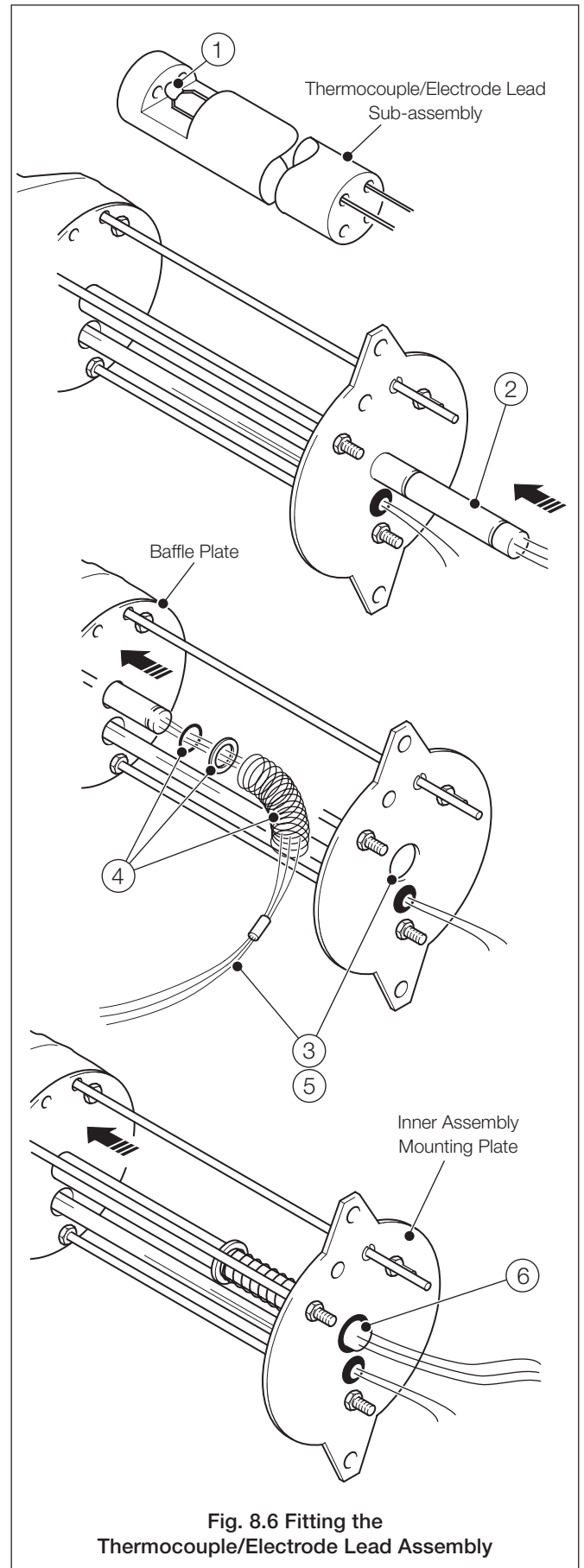

Fig. 8.6 Fitting the Thermocouple/Electrode Lead Assembly

### 8.8 Replacing the Heater Assembly (0.4m Probes) – Fig. 8.7

Remove the inner assembly as detailed in Section 8.5.

Referring to Fig. 8.7:

- ① Remove the three 6BA screws securing the heater assembly to its carrier assembly.
- ② Withdraw the heater assembly by pulling the ceramic insulators through the baffle plates.
- ③ Fit the new heater assembly, carefully guiding the heater leads and insulators through the baffle plates and ensuring that the clear hole in the heater aligns with the slot in the heater mounting plate.
- ④ Thread the heater leads through the grommet in the mounting plate.
- ⑤ Ensure that the three support rods are correctly located in the recesses on the heater mounting plate.
- ⑥ Secure the heater with the three 6BA screws.

Adjust the length of the inner assembly to suit the new heater assembly as detailed in Section 8.9.

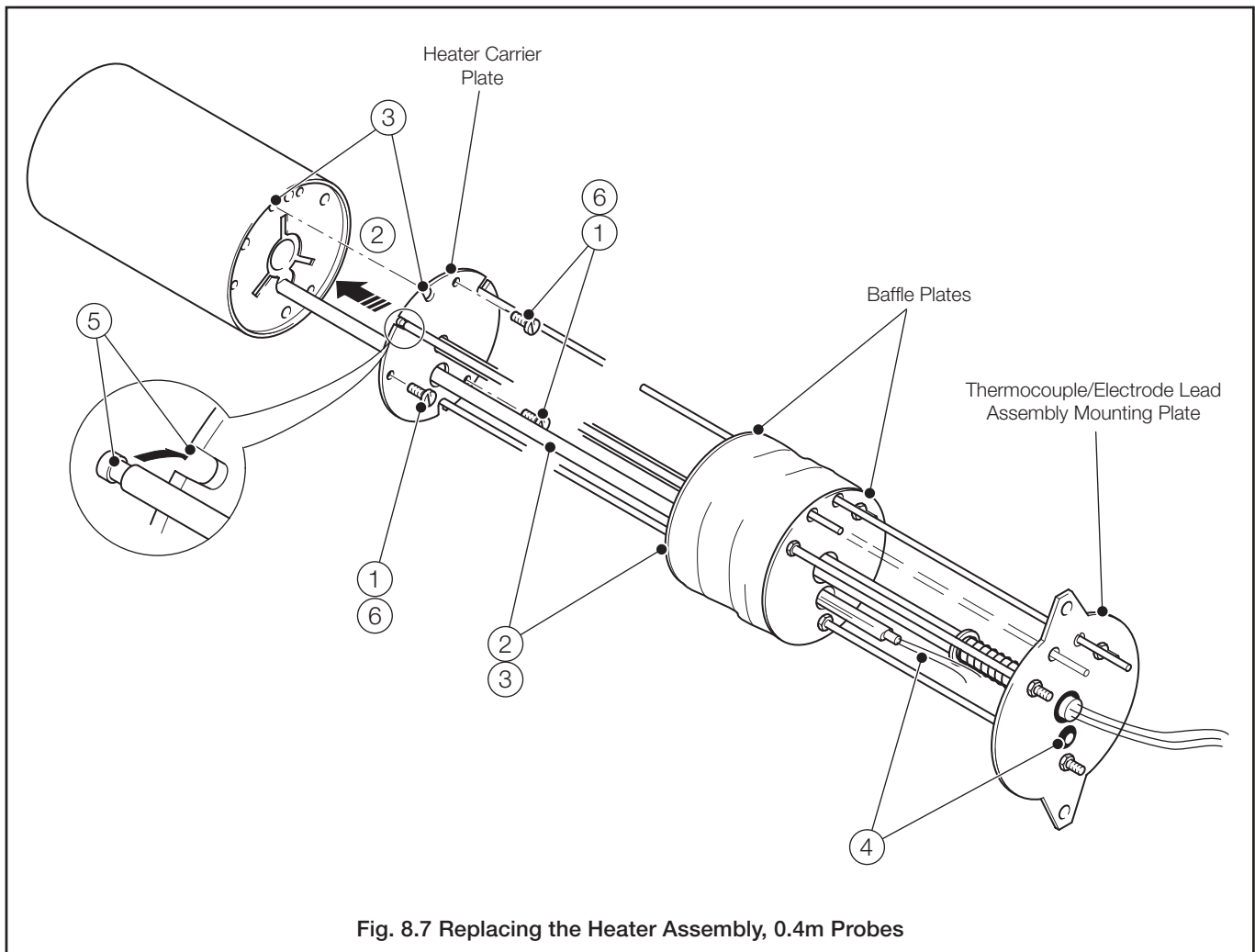

Fig. 8.7 Replacing the Heater Assembly, 0.4m Probes

### 8.9 Adjusting the Length of the Inner Assembly (all Probes) – Figs. 8.8A and 8.8B

If the heater assembly has been replaced it is necessary to adjust the length of the inner assembly to suit the new heater.

Referring to Fig. 8.8a:

- ① Slacken the three M3 nuts on the top of the mounting plate.
- ② Screw the three M3 nuts on the underside of the plate to the bottom of the thread on the extension rods.
- ③ Locate the test gas tube in the clear hole in the heater assembly and insert the inner assembly into the probe body, carefully guiding the test gas tube through the heater, baffle plates and mounting plate.

**Caution.** The inner assembly should slide freely into the probe; do not force it.

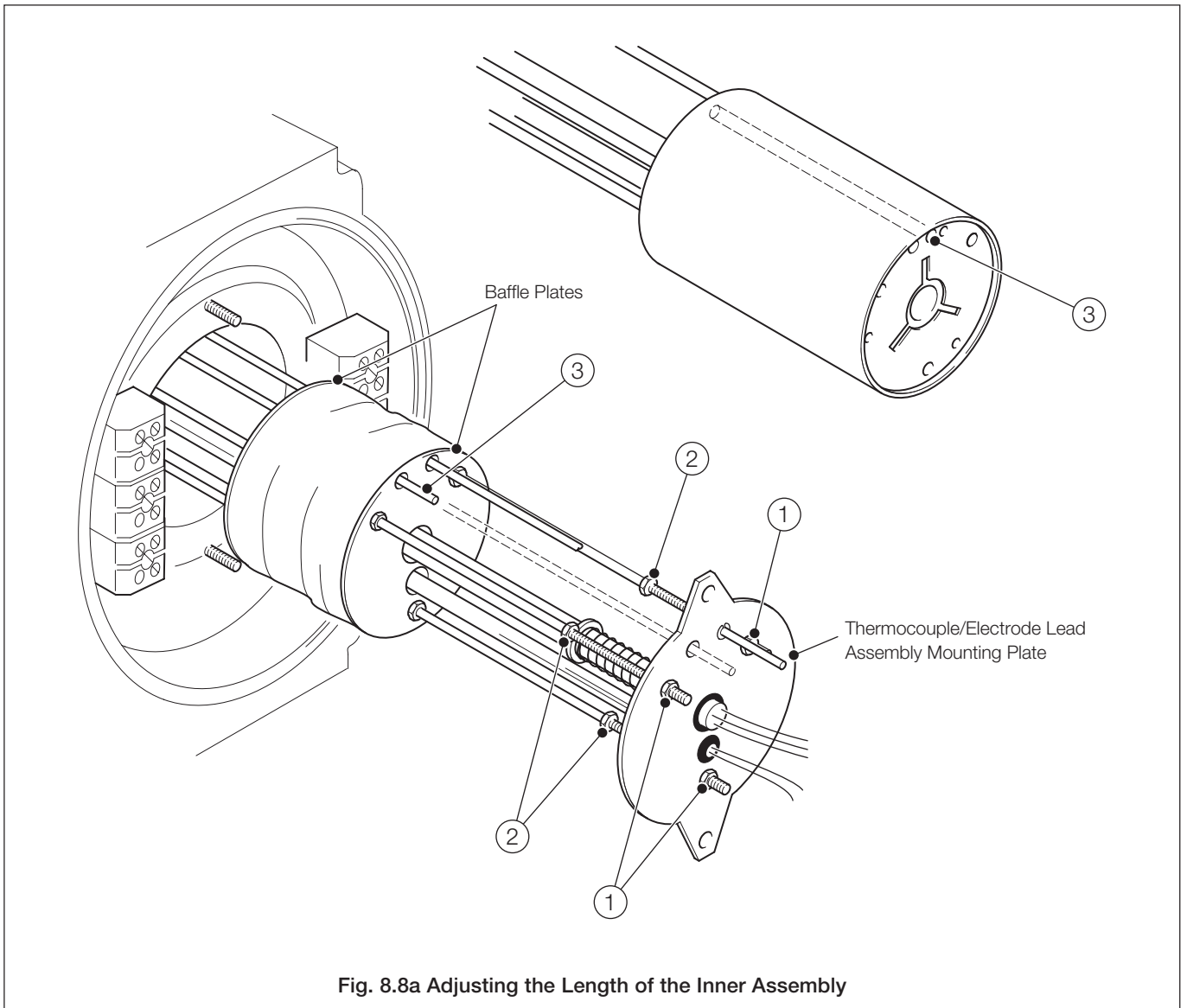

Fig. 8.8a Adjusting the Length of the Inner Assembly

...8.9 Adjusting the Length of the Inner Assembly (all Probes) – Figs. 8.8A and 8.8B

Referring to Fig. 8.8b:

- ④ Locate the mounting plate over the studs inside the head.

**Caution.** Ensure that the inner assembly is aligned correctly with the test gas tube, i.e. not twisted through 180°.

- ⑤ Firmly press the end of one support rod to push the inner assembly and heater against the end of the probe body.
- ⑥ Tighten the three M3 nuts on the top of the support rods until they just touch the mounting plate. Release the nuts by two turns.
- ⑦ Slide the complete inner assembly out of the probe body to gain access to the three M3 nuts on the underside of the mounting plate.
- ⑧ Tighten the underside nuts onto the mounting plate, ensuring that the nuts on the other side are not disturbed.
- ⑨ Re-insert the inner assembly into the probe body and secure with the two M4 pillars and shakeproof washers (finger tight only).

If the procedure has been carried out correctly, there should be between 1.0 mm and 1.5 mm clearance between the mounting plate and the head casting.

- ⑩ Ensure that the end of the test gas tube is clear of fibre.
- Align the heater assembly as detailed in Section 8.15, steps ⑤ and ⑥.

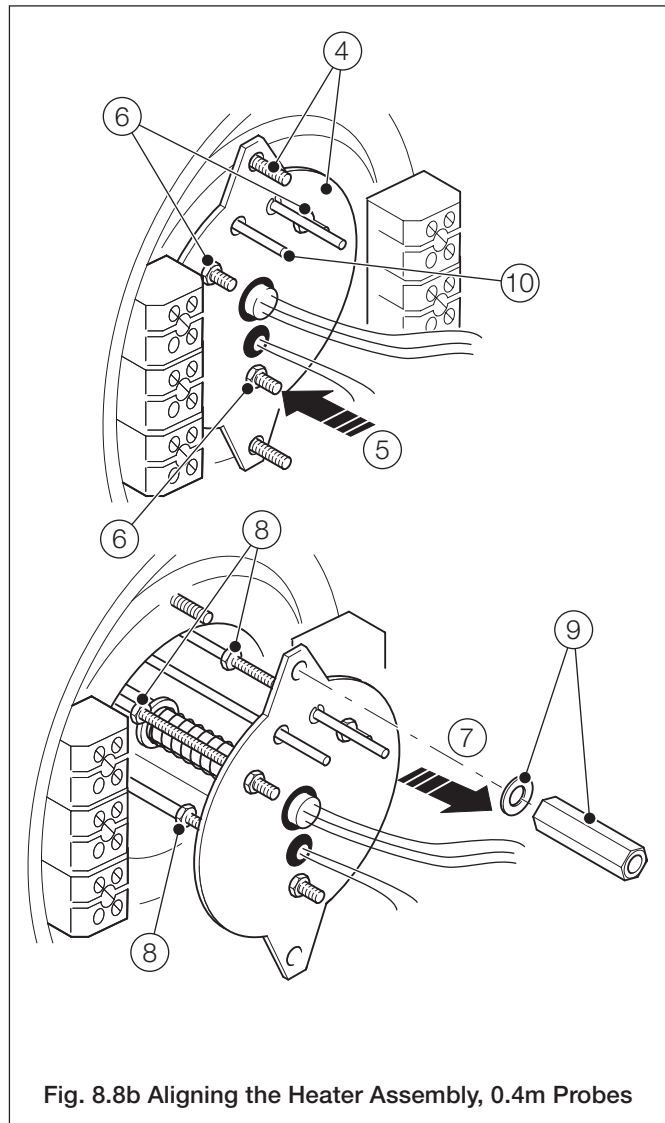

Fig. 8.8b Aligning the Heater Assembly, 0.4m Probes

8.10 Removing the Thermocouple/Electrode Lead Assembly (1.0m, 1.5m and 2.0m Probes)

Carry out the procedure detailed in Section 8.6, Fig 8.5 on page 20, noting the following:

- At step ④, remove **two** springs and M6 washers.

**Caution.** When carrying out step ⑤ the joints in the ceramic insulators may snag on the baffle plates. Take care not to damage the insulators as they are not supplied with a replacement thermocouple/electrode lead sub-assembly – see Section 8.12.

### 8.11 Re-assembling the Thermocouple/Electrode Lead Components (1.0m, 1.5m and 2.0m Probes) – Figs. 8.9 to 8.11

A replacement assembly comprises the following:

- 1 thermocouple/electrode lead sub-assembly
- 3 lengths of PTFE sleeving (red, white and blue)
- 2 lengths of rubber sleeving (black)
- 2 springs
- 2 M6 washers
- 2 rubber 'O' rings.

Referring to Fig. 8.9:

- ① Cut through the electrode wires on the old thermocouple/electrode lead sub-assembly, close to the ceramic insulator nearest the head end of the probe.
- ② Remove and retain the plain ceramic insulators from the wires:
  - 1.0m probes – two insulators
  - 1.5m probes – three insulators
  - 2.0m probes – four insulators.

Discard the old thermocouple/electrode lead sub-assembly.

Lay the thermocouple/electrode lead sub-assembly at the end of a long work surface and carefully uncoil the extension wires, one at a time.

---

**Caution.** Do not kink the wires. This will render the finished assembly unusable.

---



---

**Note.** To temporarily retain the uncoiled lead ends when refitting the ceramic insulators use a simple clamping block constructed from bulldog clips – see Fig. 8.10.

---

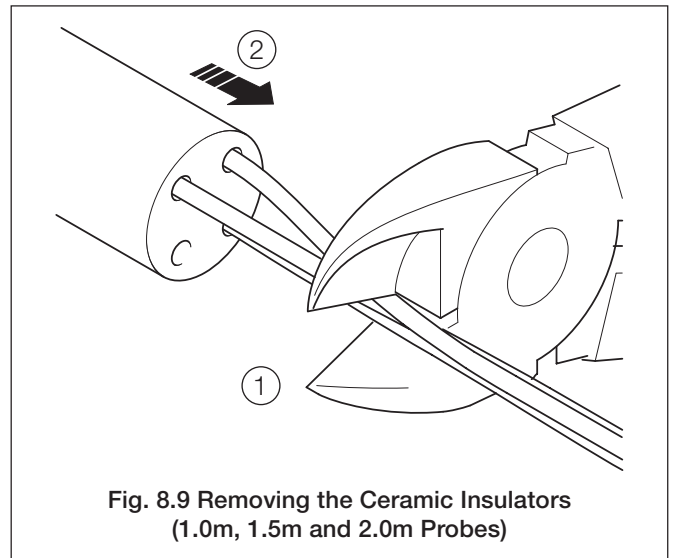

Fig. 8.9 Removing the Ceramic Insulators (1.0m, 1.5m and 2.0m Probes)

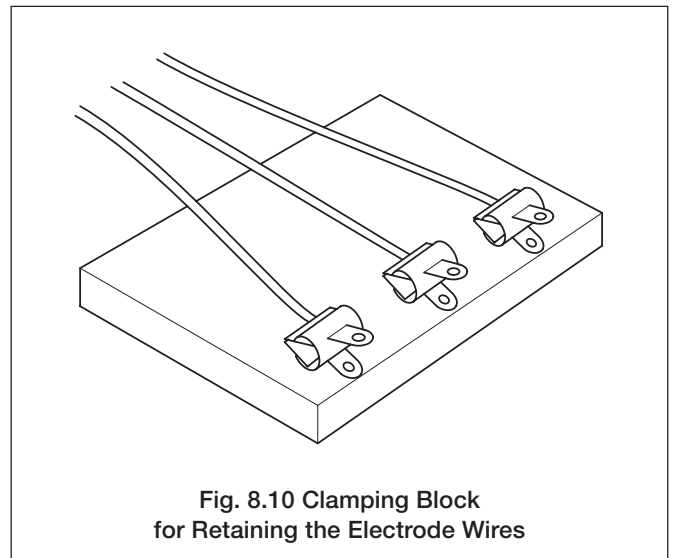

Fig. 8.10 Clamping Block for Retaining the Electrode Wires

**...8.11 Re-assembling the Thermocouple/Electrode Lead Components (1.0m, 1.5m and 2.0m Probes) – Figs. 8.9 to 8.11**

Referring to Fig. 8.11:

- ③ Thread the ceramic insulators, one at a time, onto the extension wires ensuring that each wire is located in the correct bore.

Do not attempt to thread more than half the insulator length onto a wire at any one time.

- ④ Ensure that the leads do not cross between insulators and that the insulators butt together correctly at the joints.

Wind a single turn of thin self-adhesive tape around each joint to prevent it snagging when refitting the thermocouple/electrode lead assembly.

- ⑤ Slide 250 mm of PTFE sleeving onto the wire ends and into the ceramic insulator until 200 mm protrudes. Ensure that the correct colour sleeving is used.

- ⑥ Use a magnet to check that the insulators and PTFE sleeves have been threaded onto the correct wires; the thermocouple -ve lead should be attracted by the magnet.

Cut the wires to length leaving approximately 10mm bare and then thread on the two rubber sleeves.

---

**Caution.** Do not pull excessively on the wires or the thermocouple and/or the electrode contact may be dislodged.

---

- ⑦ Check that the thermocouple bead is located at the electrode end of its cut-out i.e. butted-up against the end of the cut-out.

---

**Note.** If the bead is not correctly located, low oxygen readings may result.

---

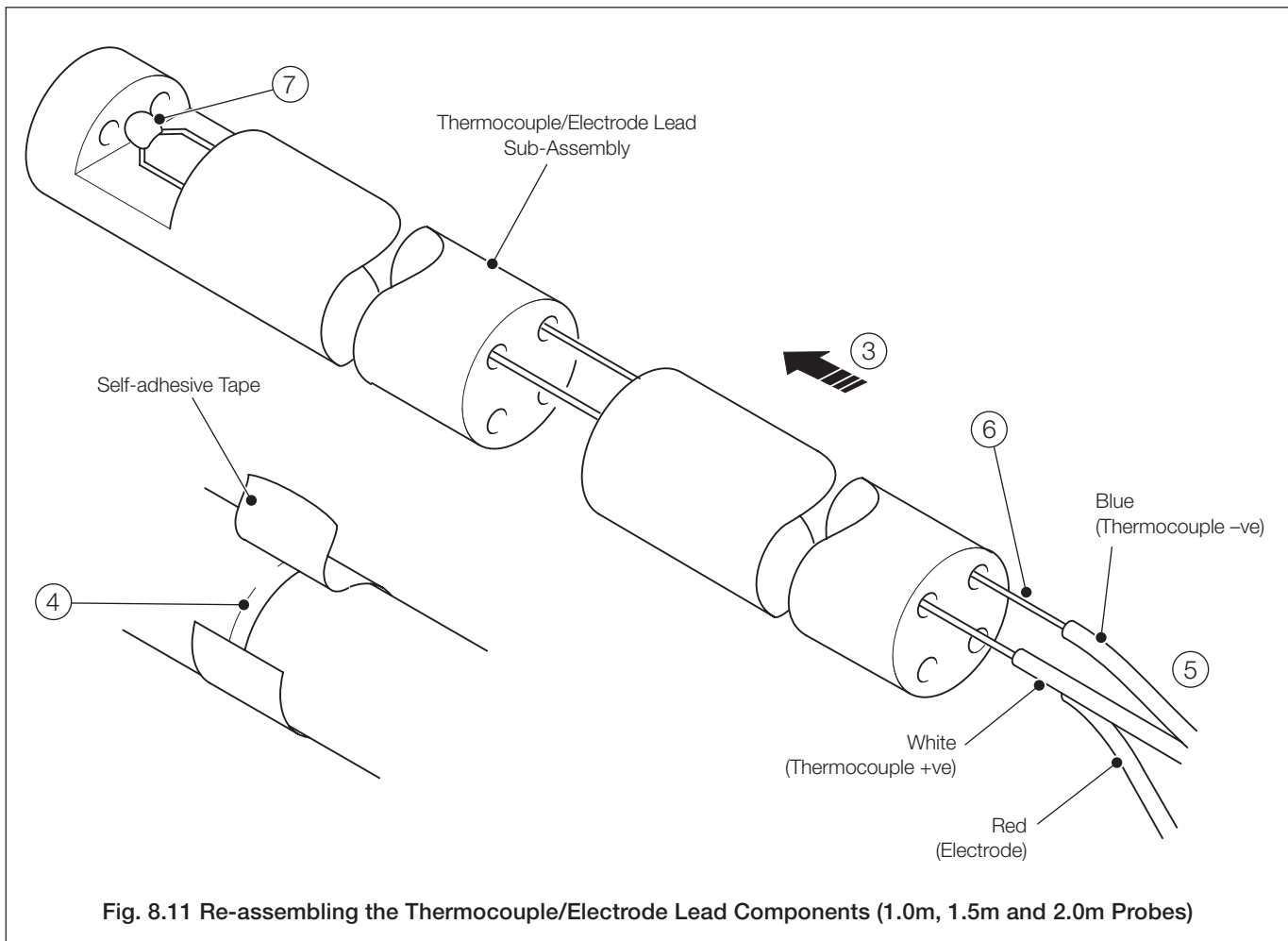

**Fig. 8.11 Re-assembling the Thermocouple/Electrode Lead Components (1.0m, 1.5m and 2.0m Probes)**

### 8.12 Fitting the Thermocouple/Electrode Lead Assembly (1.0m, 1.5m and 2.0m Probes) – Fig. 8.12

Lay the inner assembly and thermocouple/electrode lead assembly end to end on a clean flat surface, with the electrode contact facing the mounting plate.

Refit the thermocouple/electrode lead assembly as detailed in Section 8.7, Fig. 8.6 on page 21 but note also the following:

- a) remove the self-adhesive tape from the ceramic insulator joints after carrying out step ①.
- b) there are two springs and two washers to be fitted at step ④.

**Caution.** Take care not to break the head end four-bore ceramic insulator when refitting its retaining 'O' ring (step ⑥).

Refer to Fig. 8.12 to check the finished assembly.

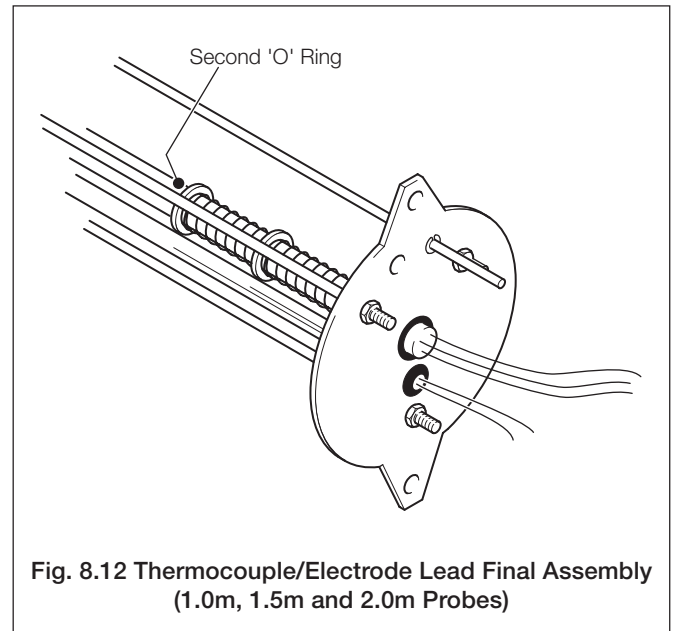

**Fig. 8.12 Thermocouple/Electrode Lead Final Assembly (1.0m, 1.5m and 2.0m Probes)**

**8.13 Replacing the Heater Assembly (1.0m, 1.5m and 2.0m Probes) – Fig. 8.13**

Remove the inner assembly as detailed in Section 8.5.

- ① Identify the connection plate.
- ② Remove the two M4 nuts retaining the heater leads and remove the leads and four M4 washers (one either side of the cable leads). Do not disturb any of the other nuts.

**Caution.** Take care not to stress the ceramic connection plate.

- ③ Remove the three 6BA screws retaining the heater to its carrier plate. (A replacement heater assembly is supplied with new screws).
- ④ Remove the heater assembly, carefully withdrawing the attached leads and ceramic insulator through the connection plate. Retain the ceramic insulator for refitting to the new heater assembly.

Check the connection plate for any cracks or fractures. If the plate is damaged it must be replaced as detailed in Section 8.14.

- ⑤ Thread the leads on the new heater assembly through the ceramic insulator.

- ⑥ Ensure that the three support rods are correctly located in the recesses in the heater mounting plate and the offset (heater ceramic) hole aligns with the corresponding holes in the connection plate and baffle plates.
- ⑦ Carefully guide the heater leads/ceramic insulator through the offset hole in the heater mounting plate and the connections plate.
- ⑧ Secure the heater assembly to its mounting plate with the three new 6BA screws.

Ensure that the M4 nuts retaining the solid heater extension leads are tight.

- ⑨ Replace the two M4 washers over the termination bolts and refit the heater leads. Replace the remaining two M4 washers and secure with the two M4 nuts.

**Caution.** Ensure that the heater leads are routed as shown in Fig. 8.14 to prevent them shorting and/or interfering with the spring-loaded operation of the thermocouple/electrode lead assembly. Leave sufficient slack in the heater leads must to allow for expansion at the probe's operating temperature.

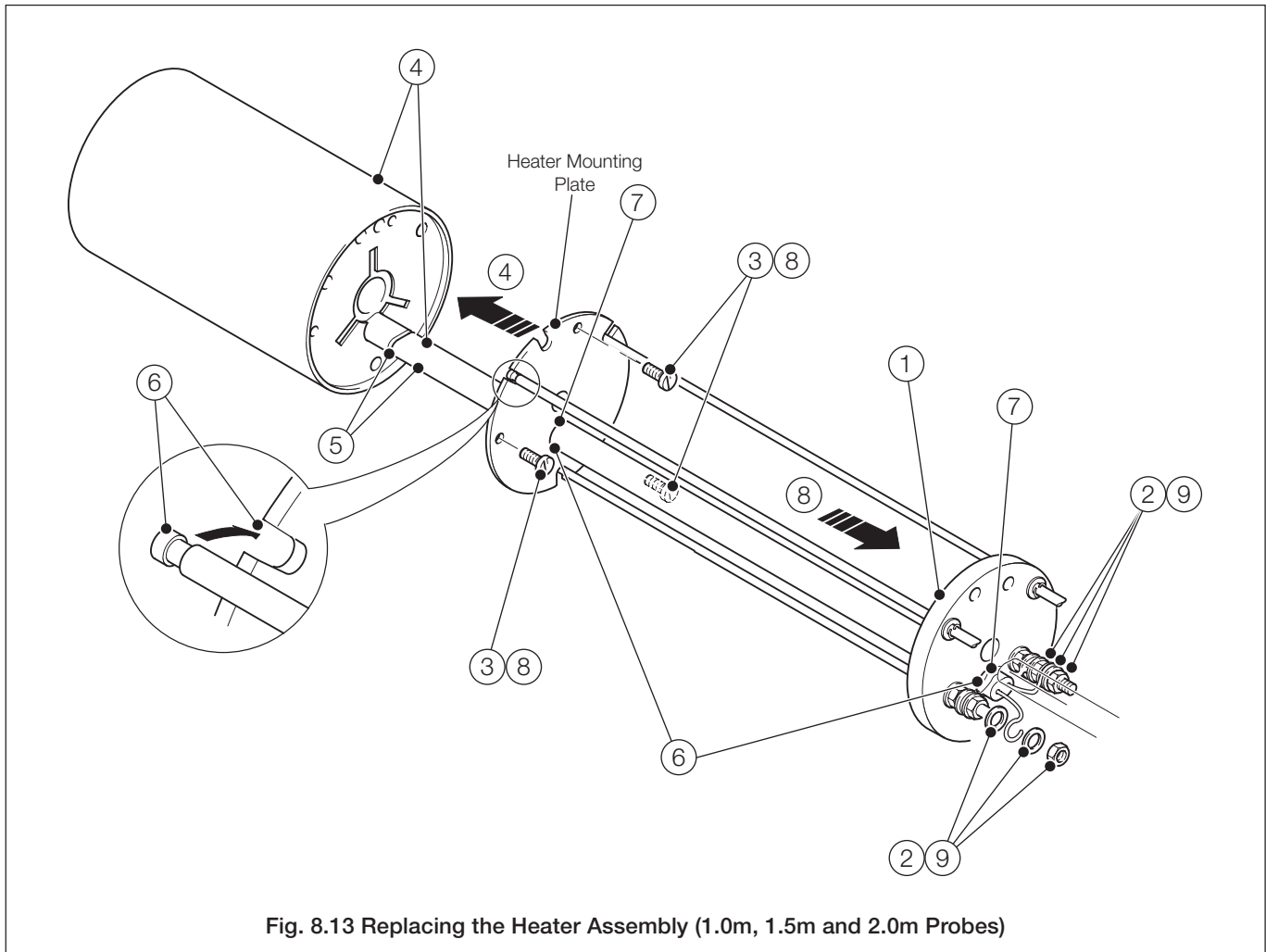

Fig. 8.13 Replacing the Heater Assembly (1.0m, 1.5m and 2.0m Probes)

### 8.14 Replacing the Connection Plate (1.0m, 1.5m and 2.0m Probes) – Figs. 8.14 and 8.15

Remove the heater assembly as detailed in Section 8.13, steps ① to ④.

- ① Remove the two M4 nuts retaining the solid heater extension wires and remove the wires and four M4 washers.
- ② Remove the three stainless steel wire twists from the extension rods (heater side of the connection plate) and retain.
- ③ Disengage the extension rods from the heater mounting plate.
- ④ Slide the connection plate off the extension rods taking care not to lose the six M3 washers on the rods.
- ⑤ Remove the two M4 nuts retaining the terminal bolts to the connection plate and remove the bolts, spacers and four M4 washers.

To fit a new connection plate, reverse the above procedure. Ensure that all connections are tight. Refer to Fig. 8.15 to check the finished assembly.

**Caution.** When refitting the bolts onto the new connection plate, (reversing step ⑤) they should move freely once tightened against the spacers. Do not to over tighten the retaining nuts in order to grip the connection plate.

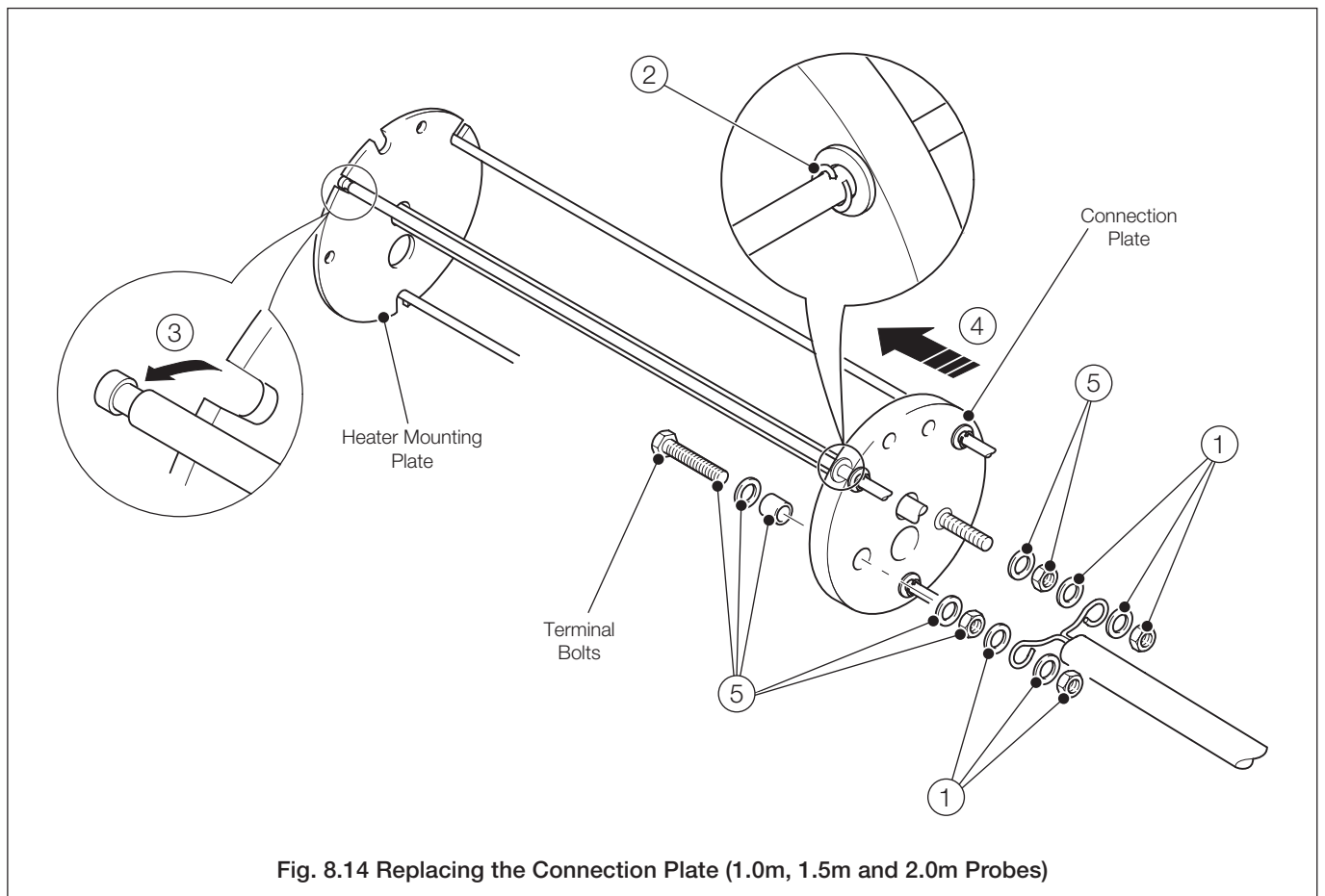
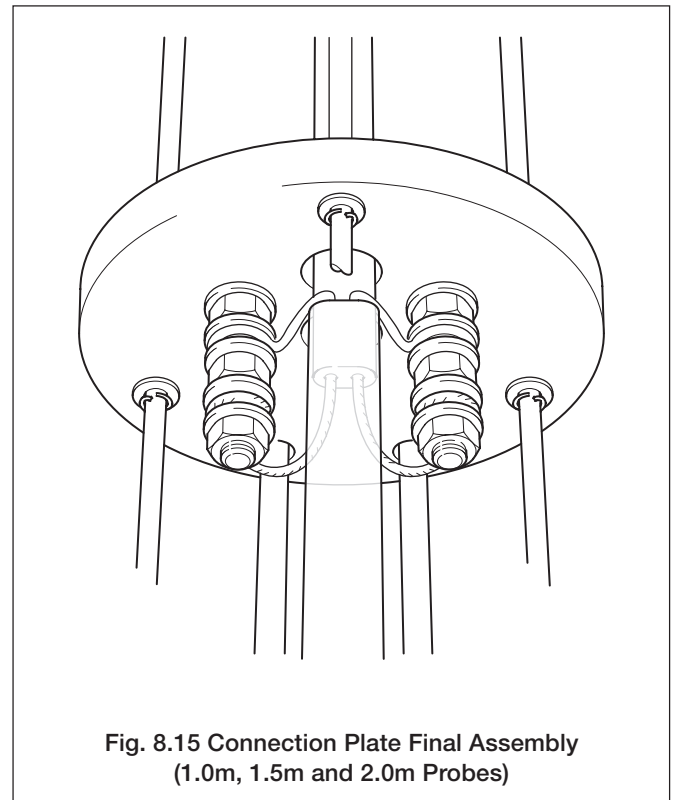

### 8.15 Refitting the Inner Assembly and Aligning the Heater (all Probes) – Figs. 8.16 and 8.17

**Caution.** Do not attempt to refit the inner assembly into the probe body with the cell in place.

With reference to Fig. 8.16:

- ① Locate the test gas tube in the clear hole in the heater assembly and insert the inner assembly into the probe body, carefully guiding the test gas tube through the heater, baffle plates and mounting plate.

**Caution.** Ensure that the inner assembly is aligned correctly with the test gas tube, i.e. not twisted through 180°.

- ② Locate the mounting plate over the studs inside the head.
- ③ Ensure that the end of the reference air tube is clear of fibre.

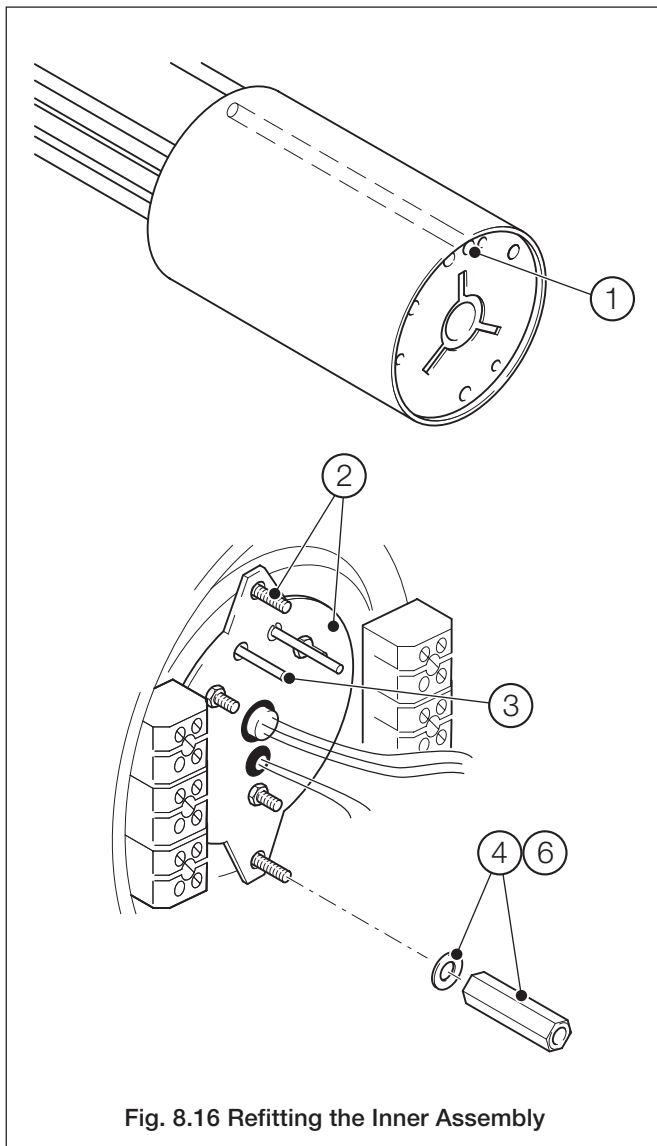

Fig. 8.16 Refitting the Inner Assembly

- ④ Secure the inner assembly with the two M4 pillars and shakeproof washers (finger tight only).

With reference to Fig. 8.17:

- ⑤ Align the heater bore concentric with the cell insertion bore in the end of the probe using a pencil or similar round tool.

**Caution.** Take extreme care not to damage the helical contact on the end of the thermocouple/electrode lead assembly.

Refit the cell as detailed in steps 1 to 4 in Section 8.4.

With reference to Fig. 8.16:

- ⑥ Fully tighten the M4 pillars.

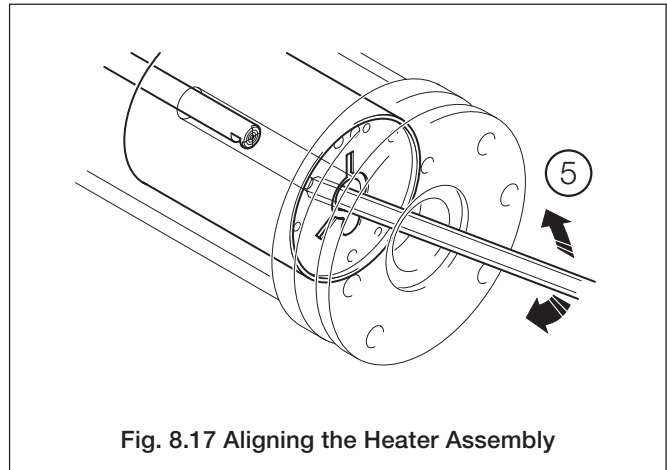

Fig. 8.17 Aligning the Heater Assembly

## 9 SPECIFICATION

### Environmental Data

#### Process gas (flue) temperature

20 to 600 °C (68 to 1112 °F)

#### Pressure

Suitable for all normal positive or negative flue pressures

#### Response rate

Standard cell < 40 s to 63 % of step change < 1 minute to 90 % of step change (typical)

Fast response cell For typically <12 s to t90 the fast response adaptor must be used\*

#### Reference gas

Clean, oil-free air. Flow rate 150 to 1000 cc/minute

#### Environmental protection

Meets requirements of IP65 and NEMA 4X (hosedown)

Probe head	IP65 rated.
Standard conduit	Intermittent wetting permitted (providing the conduit(s) hang downwards).
IP65 conduit	Once installed in a dry flue duct, all exposed parts of the probe have full IP65 protection.

\* The fast response cell is not fitted with a ceramic filter or flame arrestor. Do not use on dusty applications or on applications where the hot cell could ignite flammable gas mixtures in the flue.

### Calibration Data

#### Calibration (in situ)

One point using clean air

Two point using certified test gas and air

#### Test Gas Facility

Type	In situ (checks may be made with probe installed in operational flue duct).
Connections	1/4 in. or 6 mm o.d. compression fitting (both olive sizes supplied). 1/4 in. o.d. copper stub pipe (also supplied).
Gas ratio (between test gas O <sub>2</sub> and the sample gas surrounding the probe)	≤ 20:1.
Test gas flow requirement	3,000 cc/min. ±10 %.

### Mechanical Data

#### Construction

316 stainless steel and ceramic

#### Dimensions

See page 6

#### Weight

0.4m (16 in.) – 6kg (13.2lb) [including 6m (20 ft) cable]
1.0m (39 in.) – 10.8kg (23.7lb) [including 6m (20 ft) cable]
1.5m (58 in.) – 11.6kg (25.5lb) [including 6m (20 ft) cable]
2.0m (78 in.) – 12.5kg (27.5lb) [including 6m (20 ft) cable]

ERA Citation of suitability for gas-fired installations where Group IIB equipment is applicable.

#### Insertion lengths

0.4, 1.0, 1.5 or 2.0m (16, 39, 58 or 78 in.) standard

Specials up to 4.0m (156 in.) max.

#### Flange options

**Note.** The Flange types listed are **NOT** pressure retaining.

0.4m (16 in.) ZFG2 Standard
6.0 ±0.4 mm thick x 101.0 ±1 mm dia.
6 holes 7.3 mm dia. equispaced on 80.0 ±0.2 mm PCD
1.0, 1.5 and 2.0 m (39, 58 and 78 in.) ZFG2 Standard
12.0 ±1 mm thick x 165.0 ±0.2 mm dia.
6 holes 12.5 ±0.5 mm dia. equispaced on 140 mm PCD
Rosemount/Westinghouse Model 132 equivalent
6.0 ±0.4 mm thick x 127.0 ±1 mm dia.
4 holes 9.5 (0.375 in.) dia. equispaced on 99.0 ±0.2 mm PCD
ANSI B 16.5 (2 in.) 150 lb
12.0 ±1 mm thick x 185.0 ±0.5 mm dia.
4 holes 18 mm dia. equispaced on 145.0 ±0.2 mm PCD
DIN 2501 Part 1 DN65 PN 16, 25 and 40
12.0 ±1 mm thick x 153 ±0.5 mm dia.
4 holes 20.0 ±0.2 mm equispaced on 121.0 ±0.2 mm PCD
JIS B 2238 DN65 5K
12.0 ±1 mm thick x 155.0 ±0.5 mm dia.
4 holes 15 equispaced on 130.0 ±0.2 mm PCD

#### Cable length

10m or 6m (32 or 20 ft) fitted

Maximum distance between probe and electronics unit  
69 m (224 ft) using EXFG/0194 and EXFG/0195 cables

### Electrical Data

#### Cell constant

0 V ±2 mV

#### Cell output load

>10MΩ.

#### Heater temperature

700 °C 3 °C (973 °K)

#### Heater rating

0.4 m probe	<100 VA at 50 to 55 V AC
1.0 m, 1.5 m and 2.0 m probes	<120 VA at 50 to 55 V AC

#### Heater resistance

0.4 m probe	28 to 31Ω.
1.0 m, 1.5 m and 2.0 m probes	26 to 29Ω.

#### Thermocouple

NiCr/NiAl Pt. 4 BS4937 Part 4 Type K

#### External earth bonding

6 mm female thread



Ref.	Item	Part. No.	Ref.	Item	Part. No.
1	M4 x 20 cheesehead screw	J/0227/681	30	6BA x 1/4 in. screw	002018219
2	M4 plain washer	B7298	31	Heater mounting plate	ZFG2/0158
3	Head cover	ZFG2/0120	32	'O' ring	B10093
4	'O' ring	J/0211/001	33	Tubing	2336BX201006
5	M4 x 8 panhead screw	B5700	34	M3 x 16 cheesehead screw	B6417
6	M4 plain washer	B7298	35	6-way terminal block	B9255
7	Connections cover	ZFG2/0131	36	4-way terminal block	B9254
8	'O' ring	J/0211/001	37	Sealing ring	ZFG2/0147
9	M4 pillar	B10740	38	Union assembly (including coupling nut, olive & blanking plug)	B10721
10	M4 shakeproof washer	B7503		Nipple	B10719
11	Grommet	B10722	39	Head base :	
12	M3 full nut	B7067		20mm conduit entries	ZFG2/0118
13	M3 shakeproof washer	B6421	40	1/2 in. NPT conduit entries	ZFG2/0119
14	'O' ring	B10093		Serial number plate	003000091
15	'E' clip	B10744		1/8 in. self-tapping screw	B6220
16	Inner assembly mounting plate	ZFG2/0160	41	M10 plain washer	B10717
17	Reference air pipe	ZFG2/0184	42	Male adaptor union	B10720
18	Spring	B10723	43	Blanking plug	B10734
19	M6 plain washer	B9283	44	M4 locking washer	B7503
20	'O' ring	B10093	45	M4 x 16 socket head screw	B7295
21	Complete heater assembly comprising:	ZFG2/0035	46	Probe body:	
	Heater			Standard flange	ZFG2/0195
	Heater ceramic insulator			ANSI flange	ZFG2/0196
	Head end heater ceramic insulator			JIS flange	ZFG2/0197
	6BA x 1/4 in. cheesehead screws			DIN	ZFG2/0198
	Clear sleeving			Model 132	ZFG2/0199
	Black rubber sleeving		47	M4 full nut	B8690
	Clear heatshrink sleeving		48	Stainless steel 'O' ring	002310036
22	Extension rods (head)	ZFG2/0149	49	Cell assembly	003000105SP
23	Complete thermocouple/electrode lead assembly	ZFG2/0036	50	M4 x 10 socket head screw	B9760
24	M3 full nut	B7067	51	Flame arrester	003000087
25	Baffle plate	ZFG2/0156	52	Filter gasket	003000094
26	Pillars	ZFG2/0162	53	Ceramic filter	003000345
27	Ceramic fibre baffle	ZFG2/0164	54	Filter clamp assembly	003000346
28	M3 full nut	B7067	55	M4 x 58 socket head screw	002101115
29	Extension rods (heater)	ZFG2/0153			

Spares List for 0.4m Probes – Fig. 10.1

10.2 1.0m, 1.5m and 2.0m Probe Spares

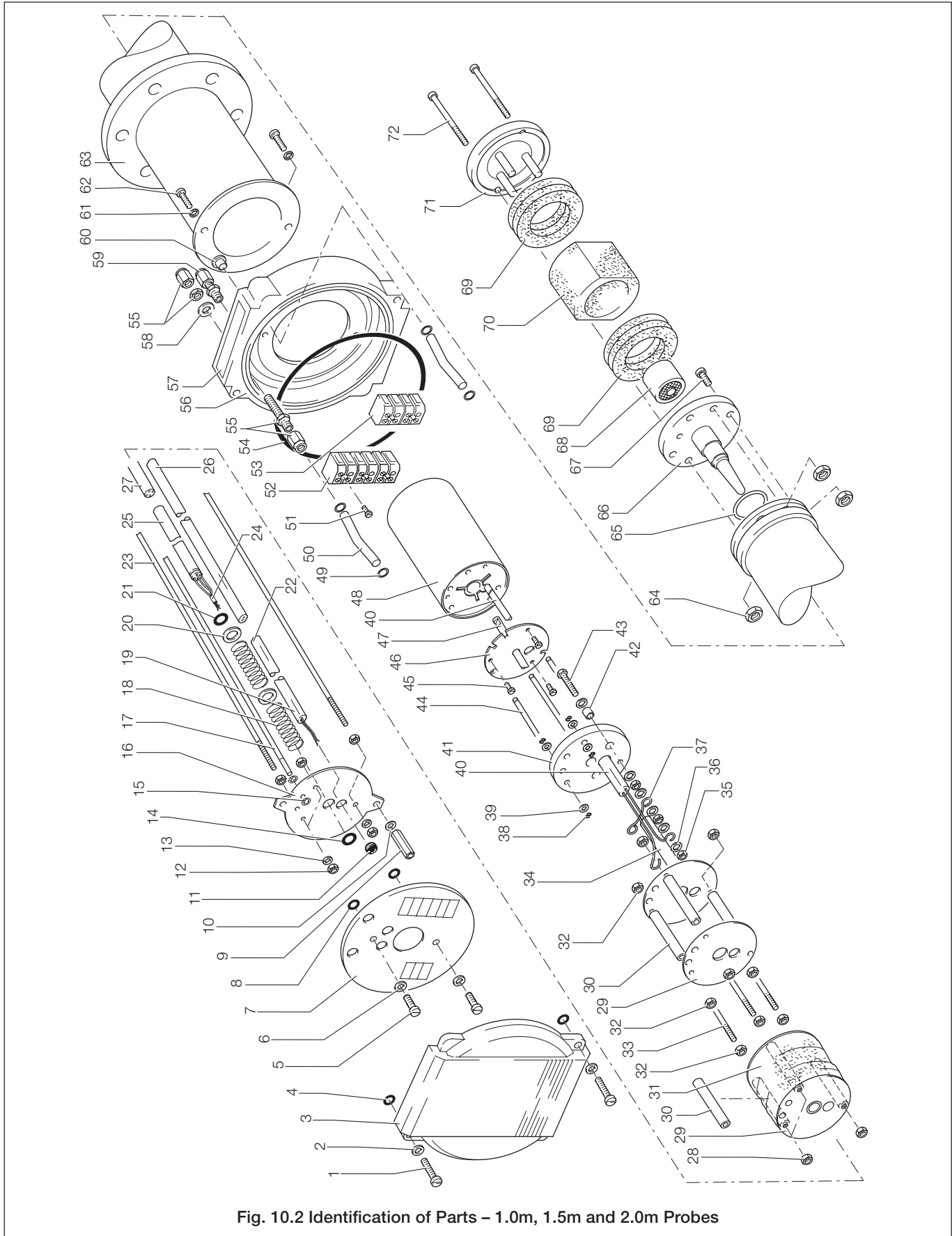

Fig. 10.2 Identification of Parts – 1.0m, 1.5m and 2.0m Probes

Ref.	Item	Part. No.	Ref.	Item	Part. No.	Ref.	Item	Part. No.
1	M4 x 20 cheesehead screw	.....J/0227/681	26	Heater extension insulator	.....RMV331	55	Union assembly	.....B10721
2	M4 plain washer	.....B7298	27	Thermocouple extension insulator	.....RMV332		Nipple	.....B10719
3	Head cover	.....ZFG2/0120	28	M3 full nut	.....B7067	56	Head base:	
4	'O' ring	.....J/0211/001	29	Baffle plate	.....ZFG2/0156		20mm conduit entries	.....ZFG2/0118
5	M4 x 8 panhead screw	.....B5700	30	Pillar	.....ZFG2/0162	57	Serial number plate	.....003000091
6	M4 plain washer	.....B7298	31	Ceramic fibre baffle	.....ZFG2/0164		1/8 in. self-tapping screw	.....B6220
7	Connections cover	.....ZFG2/0131	32	M3 full nut	.....B7067	58	M10 plain washer	.....B10717
8	'O' ring	.....J/0211/001	33	Extension support rods	.....ZFG2/0152	59	Male adaptor union	.....B10720
9	Pillar	.....B10740	34	Heater ceramic insulators	.....RMV333	60	Blanking plug	.....B10734
10	M4 shakeproof washer	.....B7503	35	M4 full nut	.....B8690	61	M4 locking washer	.....B7503
11	Grommet	.....B10722	36	M4 plain washer	.....B7298	62	M4 x 16 socket head screw	.....B7295
12	M3 full nut	.....B7067	37	1.6mm dia. nickel wire (heater extension)	.....001351006	63	1m probe body:	
13	M3 shakeproof washer	.....B6421	38	Nichrome wire	.....YBM0774		Standard flange	.....ZFG2/0200
14	'O' ring	.....B10093	39	M3 plain washer	.....STR7143		ANSI flange	.....ZFG2/0201
15	'E' clip	.....B10744	40	2-bore ceramic tube	.....001730010		JIS flange	.....ZFG2/0202
16	Inner assembly mounting plate	.....ZFG2/0160	41	Ceramic connections plate	.....ZFG2/0128		DIN	.....ZFG2/0203
17	Reference air pipe:		42	Spacer	.....ZFG2/0129		Standard flange	.....ZFG2/0205
	1m probes	.....ZFG2/0185	43	M4 x 25 hexagon head screw	.....B10727		ANSI flange	.....ZFG2/0206
	1.5m probes	.....ZFG2/0186	44	Heater end support rods	.....ZFG2/0151		JIS flange	.....ZFG2/0207
	2m probes	.....ZFG2/0187	45	6BA x 1/4 in. screw	.....002018219		DIN	.....ZFG2/0208
18	Spring	.....B10723	46	Heater mounting plate	.....ZFG2/0158		Standard flange	.....ZFG2/0210
19	Heater wires:		47	Thermocouple/electrode lead sub-assembly	.....ZFG2/0037		ANSI flange	.....ZFG2/0211
	Brown	.....B2409	48	Heater assembly	.....ZFG2/0038		JIS flange	.....ZFG2/0212
	Blue	.....B2410	49	'O' ring	.....B10093		DIN	.....ZFG2/0213
	Heat shrink	.....J/0212/239	50	Tubing	.....2336BX201006	64	M4 full nut	.....B8690
20	M6 plain washer	.....B9283	51	M3 x 16 cheesehead screw	.....B6417	65	Stainless steel 'O' ring	.....002310036
21	'O' ring	.....B10093	52	6-way terminal block	.....B9255	66	Cell assembly	.....003000105SP
22	Head end heater insulator	.....ZFG2/0166	53	4-way terminal block	.....B9254	67	M4 x 10 socket head screw	.....B9760
23	Head extension rods	.....ZFG2/0150	54	Sealing ring	.....ZFG2/0147	68	Flame arrester	.....003000087
24	Insulation and sleeving:					69	Filter gasket	.....003000094
	Blue insulation	.....002410034				70	Ceramic filter	.....0030000345
	White insulation	.....002410033				71	Filter clamp assembly	.....0030000346
	Red insulation	.....002410032				72	M4 x 58 socket head screw	.....002101115
	Rubber sleeving	.....B738						
25	Head end thermocouple insulator	.....ZFG2/0168						

Spares List for 1.0m, 1.5m and 2.0m Probes – Fig. 10.2

---

## ...10 SPARES LIST

---

### 10.3 Conduit Assemblies

#### 10.3.1 Single Entry (Ref. Fig. 4.2A on page 12)

Standard 6 m .....	003000166
Standard 10 m .....	ZFG2/0060
IP65 6 m .....	ZFG2/0066
IP65 10 m .....	ZFG2/0066
Coupling (including lock nut) .....	B10728
M20 plain washer .....	YZ2291
M20 threaded bung .....	STT1826

#### 10.3.2 Double Entry (Ref. Fig. 4.2B on page 12)

Standard 6 m (Power) .....	ZFG2/0061
Standard 6 m (Signal) .....	ZFG2/0062
Standard 10 m (Power) .....	ZFG2/0063
Standard 10 m (Signal) .....	ZFG2/0064
IP65 6 m (Power) .....	ZFG2/0067
IP65 6 m (Signal) .....	ZFG2/0068
IP65 10 m (Power) .....	ZFG2/0069
IP65 10 m (Signal) .....	ZFG2/0070
Coupling (including lock nut) .....	B10728
M20 plain washer .....	YZ2291
M20 threaded bung .....	STT1826

### 10.4 Pump and Regulator Units for External Reference Air Supply

Mains-powered pump unit .....	003000240
Flow regulator unit .....	003000241

### 10.5 Filter Deflector

Filter deflector assembly .....	003000356
---------------------------------	-----------

---

**Note.** If the filter deflector is for use on a 0.4m probe, contact the company before ordering.

---

## APPENDICES

### A1 Removing a Welded Cell – Fig. A1.1

During prolonged service the cell tip may become welded to the helical contact on the end of the thermocouple/electrode lead assembly and thus prevent removal of the cell.

To free the cell, the thermocouple/electrode lead assembly must be released as detailed in this section to allow it to slide out of the probe with the cell.

Carry out the instructions detailed in Section 4.2.1 to gain access to the inside of the head.

With reference to Fig. A1.1:

- ① Slide the rubber 'O' ring off the electrode insulator and allow the electrode assembly to slide through its mounting plate under spring pressure.

---

**Note.** Slide the 'O' ring a sufficient distance along the leads to prevent it passing through the mounting plate.

---

Temporarily replace the head cover to prevent damage to the released thermocouple/electrode lead assembly.

- ② Lay the probe on its side and gently ease the cell mount out of the probe end until approximately 10mm of the thermocouple/electrode lead assembly is visible.

---

**Caution.** If the thermocouple/electrode lead assembly cannot be easily withdrawn it is possible that one of the ceramic insulator joints has caught on a baffle plate – see Fig. 8.7. If necessary, gently tap the probe body to free the joint.

---

- ③ Use a scalpel or similar tool to carefully separate the cell tip from the helical contact on the end of the inner electrode.

---

**Caution.** Take great care not to damage the helical contact; the contact is an integral part of the thermocouple/electrode lead assembly which can only be replaced as a complete unit.

---

- a) To relocate the thermocouple/electrode lead assembly remove the inner assembly (steps ① to ④ in Section 8.5) and then carry out step ③ in Section 8.7.
- b) Refit the inner assembly as detailed in Section 8.15.
- c) Fit a new cell as detailed in Section 8.4.
- d) Fit the ceramic filter as detailed in Section 8.2.
- e) Reconnect the cell, thermocouple and heater leads by reversing steps ① and ② in Section 8.5.
- f) Reassemble the head by reversing the steps detailed in Section 4.2.1.

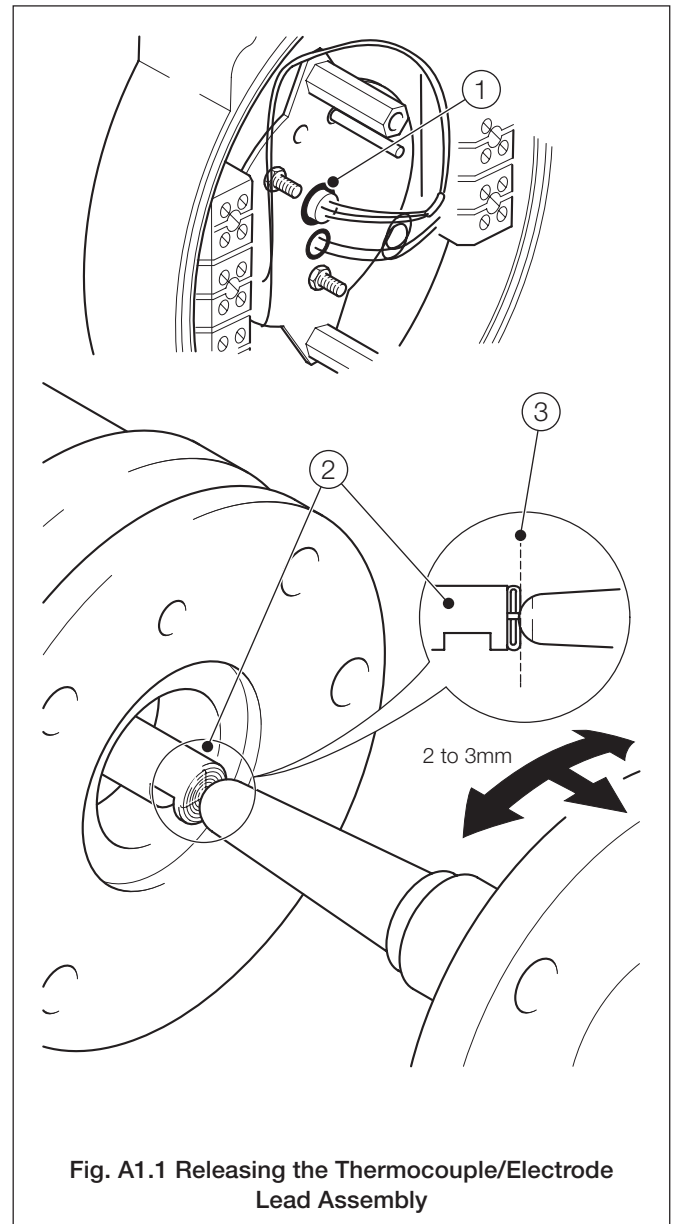

### A2 Flow Through Sample Chamber (0.4m Probes)

A sample chamber may be fitted to the end of a 0.4 m Z-FG probe for dry analysis of flue gases – see Fig. A2.1. The sample gas must be pre-conditioned (clean and dry) as for use with infrared analysers for emissions monitoring. The sample flow rate must not exceed 1 litre/minute.

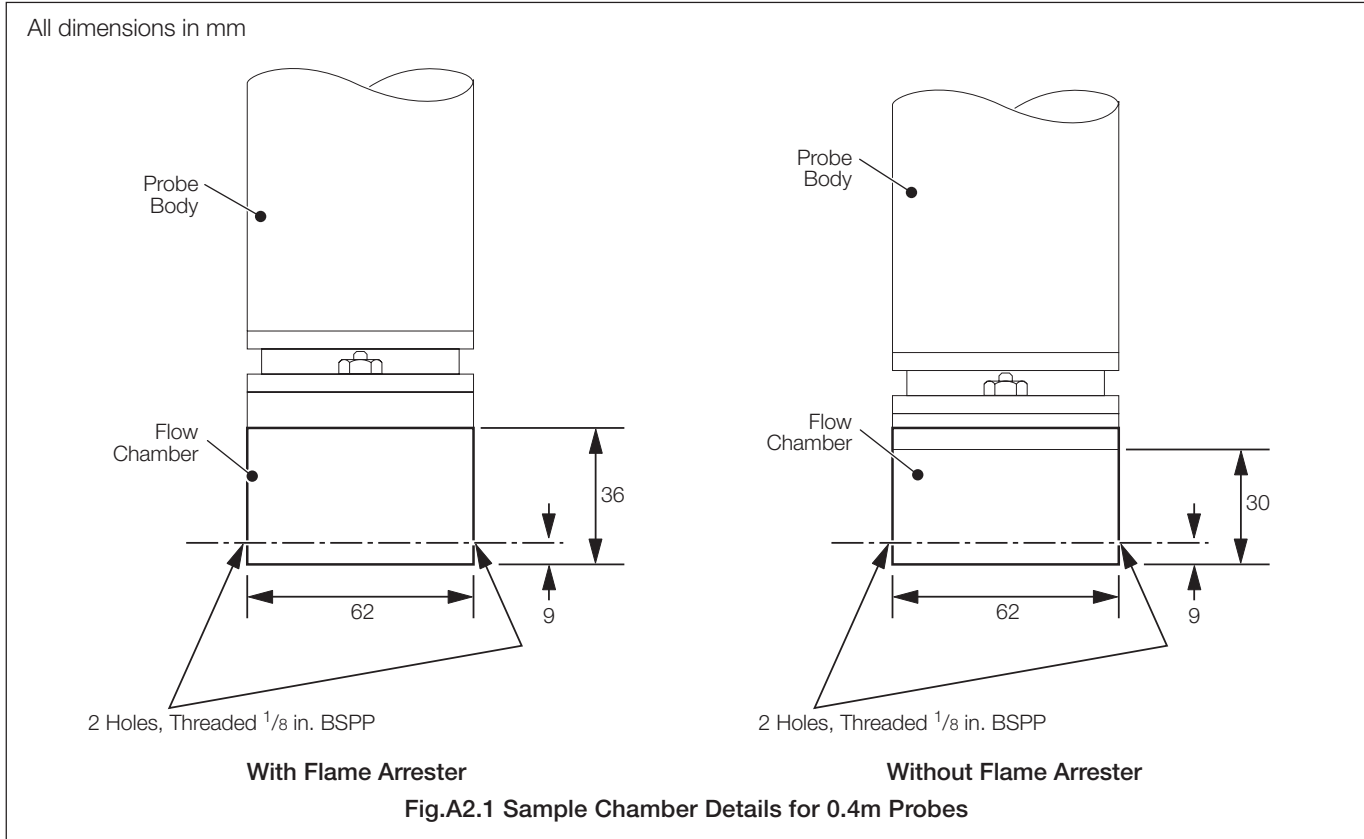

### A3 Probe Checking Using the Nernst Equation

The Nernst equation can be used for more accurate checking of the cell output than can be determined from the graph shown in Fig. 1.2 on page 3. The equation is used to calculate the theoretical cell output for a given certified test gas, as follows:

$$EmV = 0.0496 T \left( \log_{10} \frac{P_0}{P_1} \right) \pm CmV$$

Where:

- 0.0496 = gas constant
- T = absolute temperature (937°K)
- P<sub>0</sub> = reference O<sub>2</sub> partial pressure (21%)
- P<sub>1</sub> = measured O<sub>2</sub> partial pressure (% test gas)
- C = cell constant (typically ±1mV for a new cell)

#### Example 1.

For a certified test gas of 20.95%O<sub>2</sub> (air):

$$EmV = 0.0496 \times 973 \left( \log_{10} \frac{20.95}{20.95} \right) \pm CmV$$

$$EmV = 48.2608 \left( \log_{10} 1 \right) \pm CmV$$

$$EmV = CmV \text{ (cell constant)}$$

This method for calculating the cell constant is used in the Diagnostics Page of the ZDT electronics unit – see Section 12.3 of the ZDT Operating Instructions *IM/ZDT*.

#### Example 2.

For a certified test gas of 1%O<sub>2</sub>:

$$EmV = 0.0496 \times 973 \left( \log_{10} \frac{20.95}{1.00} \right) \pm CmV$$

$$EmV = 48.2608 \left( \log_{10} 20.95 \right) \pm CmV$$

$$EmV = 63.76mV \pm CmV$$

#### Example 3.

For a certified test gas of 10%O<sub>2</sub>:

$$EmV = 0.0496 \times 973 \left( \log_{10} \frac{20.95}{10.00} \right) \pm CmV$$

$$EmV = 48.2608 \left( \log_{10} 2.095 \right) \pm CmV$$

$$EmV = 15.50mV \pm CmV$$

---

**Note.** Pure N<sub>2</sub>, or any other inert gas, cannot be used to calibrate a zirconia system 'gas zero' since this equates to an infinite cell output voltage. A gas with a known value close to zero, e.g. 1% O<sub>2</sub> in N<sub>2</sub>, must be used for this purpose.

---

---

## NOTES

---



# PRODUCTS & CUSTOMER SUPPORT

## Products

### Automation Systems

- *for the following industries:*
  - Chemical & Pharmaceutical
  - Food & Beverage
  - Manufacturing
  - Metals and Minerals
  - Oil, Gas & Petrochemical
  - Pulp and Paper

### Drives and Motors

- *AC and DC Drives, AC and DC Machines, AC Motors to 1kV*
- *Drive Systems*
- *Force Measurement*
- *Servo Drives*

### Controllers & Recorders

- *Single and Multi-loop Controllers*
- *Circular Chart and Strip Chart Recorders*
- *Paperless Recorders*
- *Process Indicators*

### Flexible Automation

- *Industrial Robots and Robot Systems*

### Flow Measurement

- *Electromagnetic Flowmeters*
- *Mass Flow Meters*
- *Turbine Flowmeters*
- *Flow Elements*

### Marine Systems & Turbochargers

- *Electrical Systems*
- *Marine Equipment*
- *Offshore Retrofit and Refurbishment*

### Process Analytics

- *Process Gas Analysis*
- *Systems Integration*

### Transmitters

- *Pressure*
- *Temperature*
- *Level*
- *Interface Modules*

### Valves, Actuators and Positioners

- *Control Valves*
- *Actuators*
- *Positioners*

### Water, Gas & Industrial Analytics Instrumentation

- *pH, Conductivity, and Dissolved Oxygen Transmitters and Sensors*
- *Ammonia, Nitrate, Phosphate, Silica, Sodium, Chloride, Fluoride, Dissolved Oxygen and Hydrazine Analyzers.*
- *Zirconia Oxygen Analyzers, Katharometers, Hydrogen Purity and Purge-gas Monitors, Thermal Conductivity.*

## Customer Support

We provide a comprehensive after sales service via a Worldwide Service Organization. Contact one of the following offices for details on your nearest Service and Repair Centre.

### United Kingdom

ABB Limited  
Tel: +44 (0)1453 826661  
Fax: +44 (0)1453 829671

### United States of America

ABB Inc.  
Tel: +1 775 850 4800  
Fax: +1 775 850 4808

#### Client Warranty

Prior to installation, the equipment referred to in this manual must be stored in a clean, dry environment, in accordance with the Company's published specification.

Periodic checks must be made on the equipment's condition. In the event of a failure under warranty, the following documentation must be provided as substantiation:

1. A listing evidencing process operation and alarm logs at time of failure.
2. Copies of all storage, installation, operating and maintenance records relating to the alleged faulty unit.

---

ABB has Sales & Customer Support  
expertise in over 100 countries worldwide

[www.abb.com](http://www.abb.com)

The Company's policy is one of continuous product  
improvement and the right is reserved to modify the  
information contained herein without notice.

Printed in UK (10.07)

© ABB 2007



**ABB Limited**  
Oldends Lane, Stonehouse  
Gloucestershire  
GL10 3TA  
UK  
Tel: +44 (0)1453 826661  
Fax: +44 (0)1453 829671

**ABB Inc.**  
Analytical Instruments  
9716 S. Virginia St., Ste. E  
Reno, Nevada 89521  
USA  
Tel: +1 775 850 4800  
Fax: +1 775 850 4808