



The Company

We are an established world force in the design and manufacture of instrumentation for industrial process control, flow measurement, gas and liquid analysis and environmental applications.

As a part of ABB, a world leader in process automation technology, we offer customers application expertise, service and support worldwide.

We are committed to teamwork, high quality manufacturing, advanced technology and unrivalled service and support.

The quality, accuracy and performance of the Company's products result from over 100 years experience, combined with a continuous program of innovative design and development to incorporate the latest technology.

The UKAS Calibration Laboratory No. 0255 is just one of the ten flow calibration plants operated by the Company, and is indicative of our dedication to quality and accuracy.

BS EN ISO 9001:2000



Cert. No. Q05907

EN 29001 (ISO 9001)



Lenno, Italy – Cert. No. 9/90A

Stonehouse, U.K.



Electrical Safety

This equipment complies with the requirements of CEI/IEC 61010-1:2001-2 'Safety Requirements for Electrical Equipment for Measurement, Control and Laboratory Use'. If the equipment is used in a manner NOT specified by the Company, the protection provided by the equipment may be impaired.

Symbols

One or more of the following symbols may appear on the equipment labelling:

	Warning – Refer to the manual for instructions
	Caution – Risk of electric shock
	Protective earth (ground) terminal
	Earth (ground) terminal

	Direct current supply only
	Alternating current supply only
	Both direct and alternating current supply
	The equipment is protected through double insulation

Information in this manual is intended only to assist our customers in the efficient operation of our equipment. Use of this manual for any other purpose is specifically prohibited and its contents are not to be reproduced in full or part without prior approval of the Technical Publications Department.

Health and Safety

To ensure that our products are safe and without risk to health, the following points must be noted:

1. The relevant sections of these instructions must be read carefully before proceeding.
2. Warning labels on containers and packages must be observed.
3. Installation, operation, maintenance and servicing must only be carried out by suitably trained personnel and in accordance with the information given.
4. Normal safety precautions must be taken to avoid the possibility of an accident occurring when operating in conditions of high pressure and/or temperature.
5. Chemicals must be stored away from heat, protected from temperature extremes and powders kept dry. Normal safe handling procedures must be used.
6. When disposing of chemicals ensure that no two chemicals are mixed.

Safety advice concerning the use of the equipment described in this manual or any relevant hazard data sheets (where applicable) may be obtained from the Company address on the back cover, together with servicing and spares information.

CONTENTS

1	INTRODUCTION	2
1.1	Single PID Controlle	2
1.1.1	Reverse Acting (Base) Single PID Control	2
1.1.2	Direct Acting (Acid) Single PID Control ...	3
1.2	Dual (Bi-directional) PI Controller	3
1.3	Ouput Assignment	4
2	OPERATION	5
2.1	Introduction	5
2.2	Operating Page	7
2.2.1	Single PID Controller	7
2.2.2	Dual (Bi-directional) PI Controller	8
3	OPERATOR VIEWS	10
3.1	View Set Points	10
4	PROGRAMMING	11
4.1	Setting Up Three Term (PID) Control Parameters	11
4.2	Manual Tuning	11
4.3	Configure Control	12
4.3.1	Configure Single PID Controller	13
4.3.2	Configure Dual (Bi-directional) PI Controller	16
4.4	Configure Power Failure Recovery Mode	19

1 INTRODUCTION

The AX460 Single Input pH Analyzer has been enhanced with the addition of Proportional Integral Derivative (PID) control.

PID control can be either relay output (Time Proportioning or Pulse Frequency) or analog output.

The control output can be configured as either a **Single PID Controller** (Reverse or Direct Acting) or as a **Dual PI Controller** (Bi-directional Acid/Base).

The output from the **Single PID Controller** is assignable to either a relay or an analog output.

The outputs from the **Dual PI Controller** are assignable to either relays, analog outputs or one of each type.

This supplementary manual provides additional information relevant to the PID control features of the analyzer and must be read in conjunction with the *User Guide* (IM/AX4PH).

1.1 Single PID Controller – Fig. 1.1

The single PID controller is a basic feedback control system using three-term PID control with a local set point.

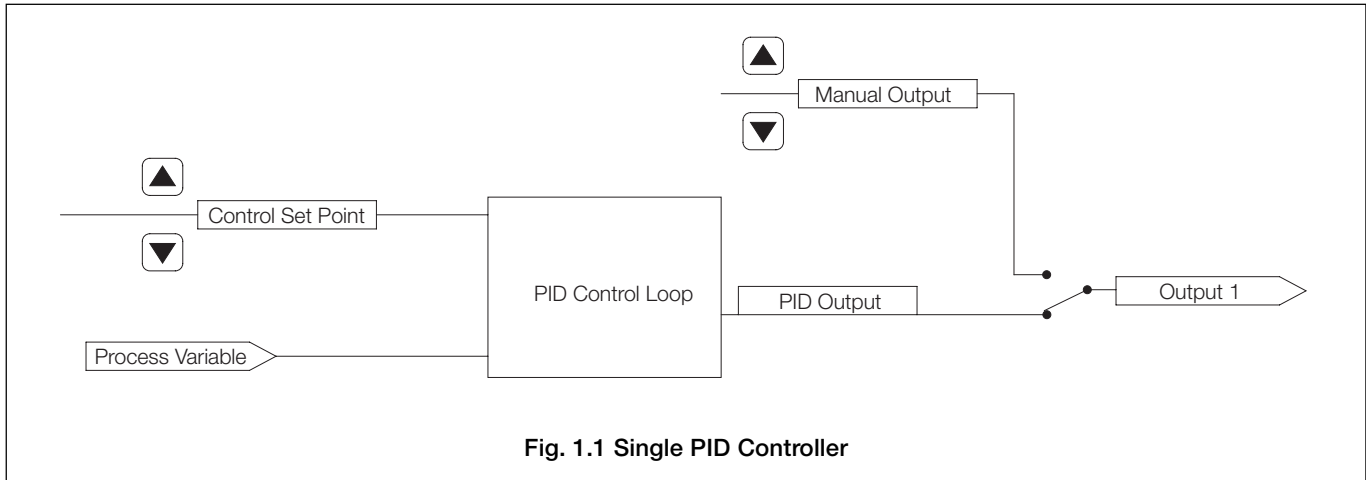

1.1.1 Reverse Acting (Base) Single PID Control – Fig. 1.2

Reverse acting control is used when the process pH is less than the required output pH. Normally, a base is added to the sample to increase the pH value.



1.1.2 Direct Acting (Acid) Single PID Control – Fig. 1.3

Direct acting control is used when the process pH is greater than the required output pH. Normally, acid is added to the sample to decrease the pH value.

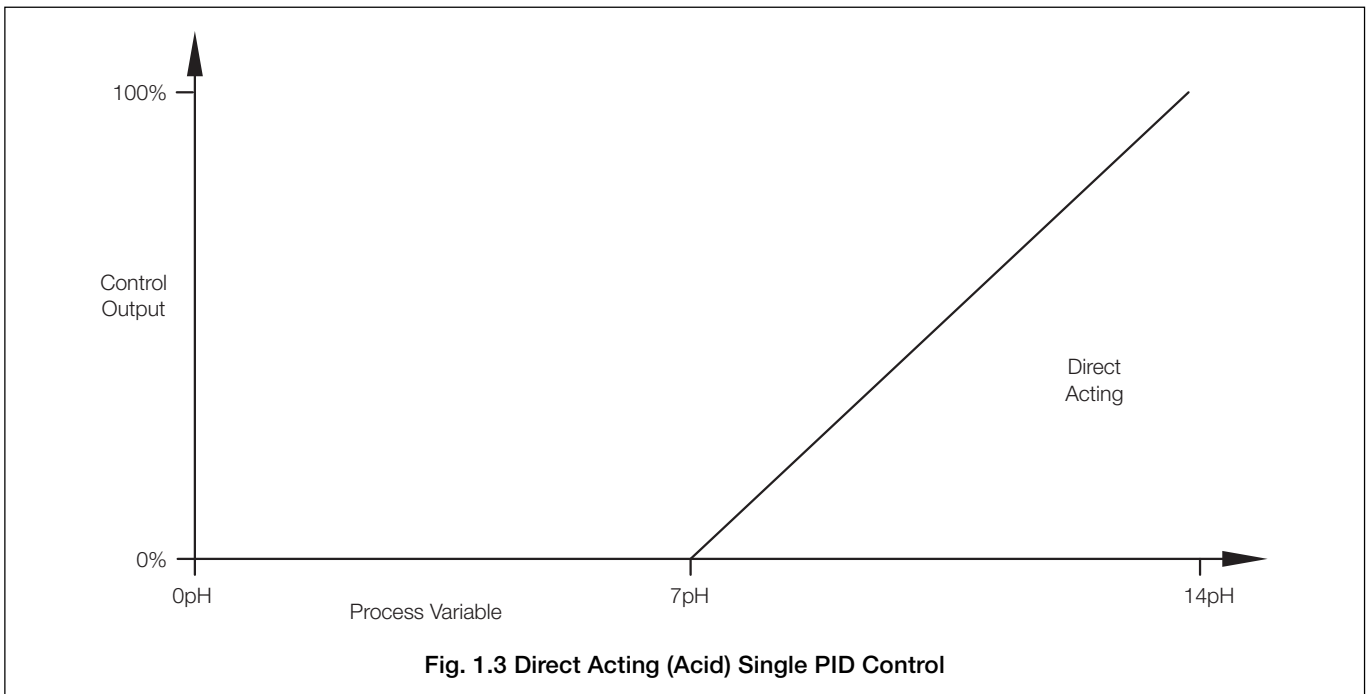

Fig. 1.3 Direct Acting (Acid) Single PID Control

1.2 Dual (Bi-directional) PI Controller – Figs 1.4 and 1.5

The dual (bi-directional) PI controller is a dual-feedback control system using P + I control with two local set points.

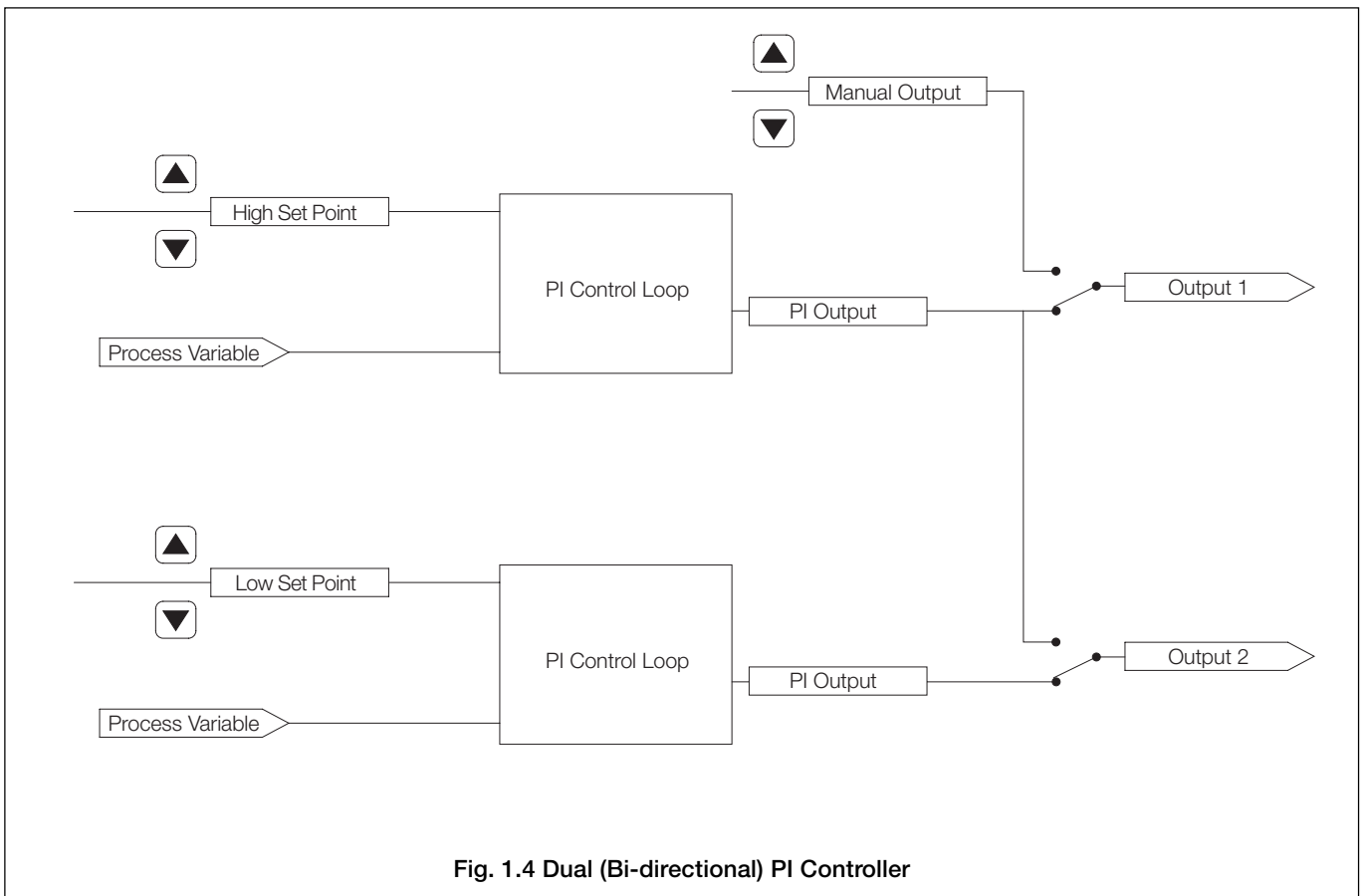
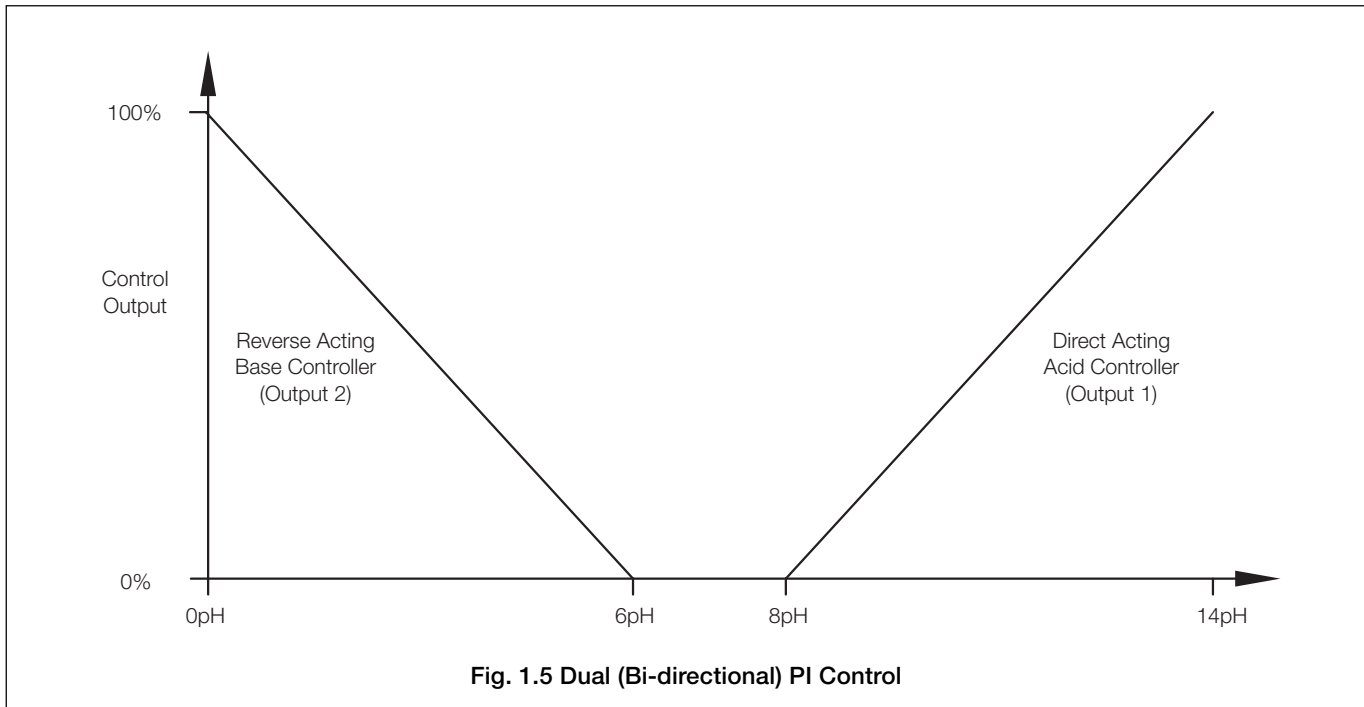

Fig. 1.4 Dual (Bi-directional) PI Controller

...1 INTRODUCTION

...1.2 Dual (Bi-directional) PI Controller – Figs 1.4 and 1.5

Dual (bi-directional) control is used if the pH value must be controlled within specified upper and lower limits. The minimum span between set points is 0.5pH.



1.3 Output Assignment

For single PID control, the output signal is assignable to either relay 1 or analog output 1. For dual (bi-directional) PI control, the output signals are assignable to any two of the following outputs: relay 1, relay 2, analog output 1 and analog output 2 – see Table 1.1 and Section 4.3.

Single PID Controller

Output Type	Relay 1	Relay 2	Relay 3	AO 1	AO 2
Analog	X	X	X	✓	X
Time or Pulse	✓	X	X	X	X

Dual (Bi-directional) PI Controller

Output Type (Direct Acting – Acid Controller)	Output Type (Reverse Acting – Base Controller)	Relay 1	Relay 2	Relay 3	AO 1	AO 2
Analog	Analog	X	X	X	✓	✓
Time or Pulse	Analog	✓	X	X	X	✓
Analog	Time or Pulse	X	✓	X	✓	X
Time or Pulse	Time or Pulse	✓	✓	X	X	X

Table 1.1 Output Assignment

2 OPERATION

2.1 Introduction

The location of the PID controller programming pages and menus within the analyzer's operating software is shown in the overall programming charts – see Figs. 2.1 and 2.2.

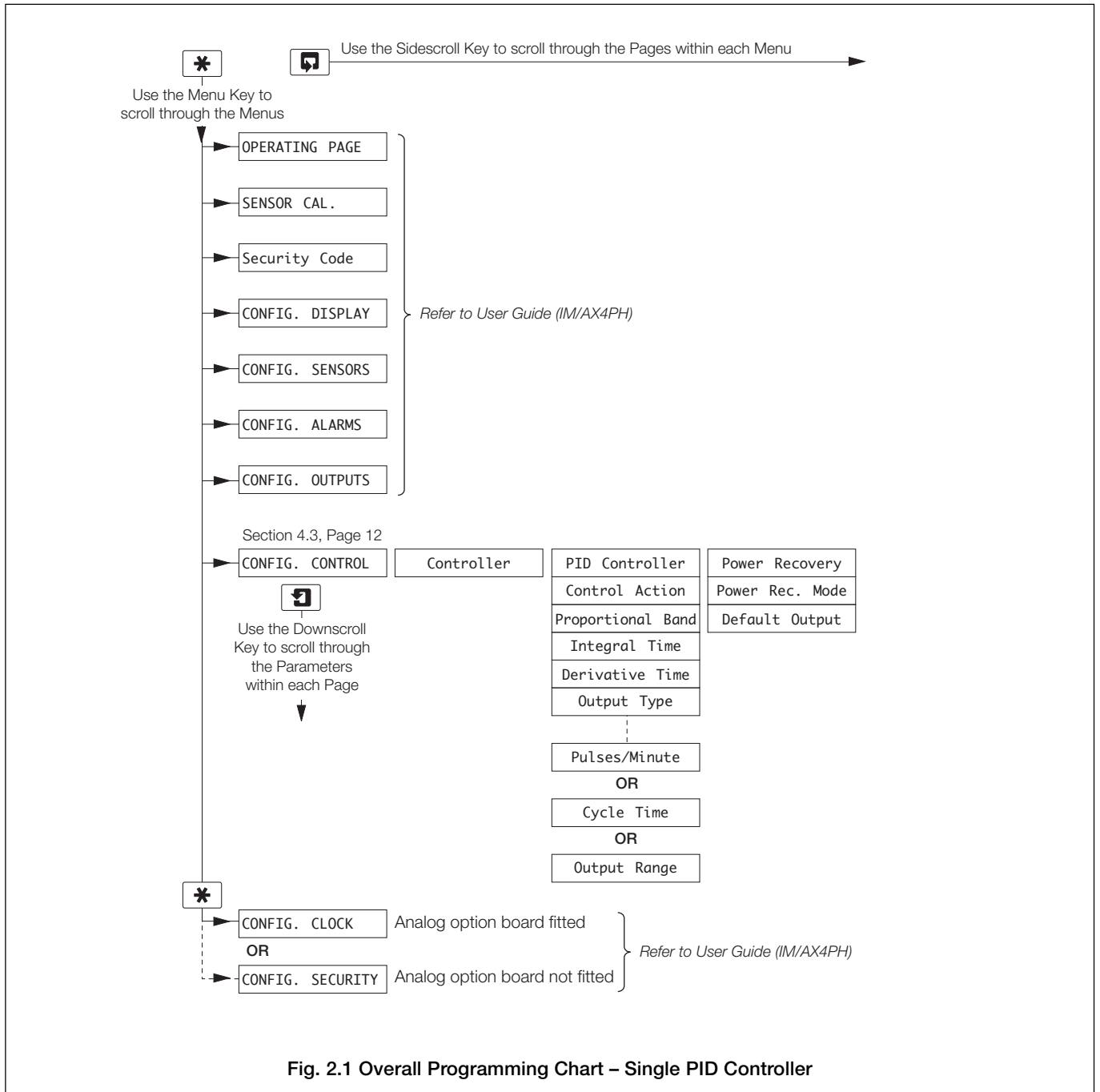

Fig. 2.1 Overall Programming Chart – Single PID Controller

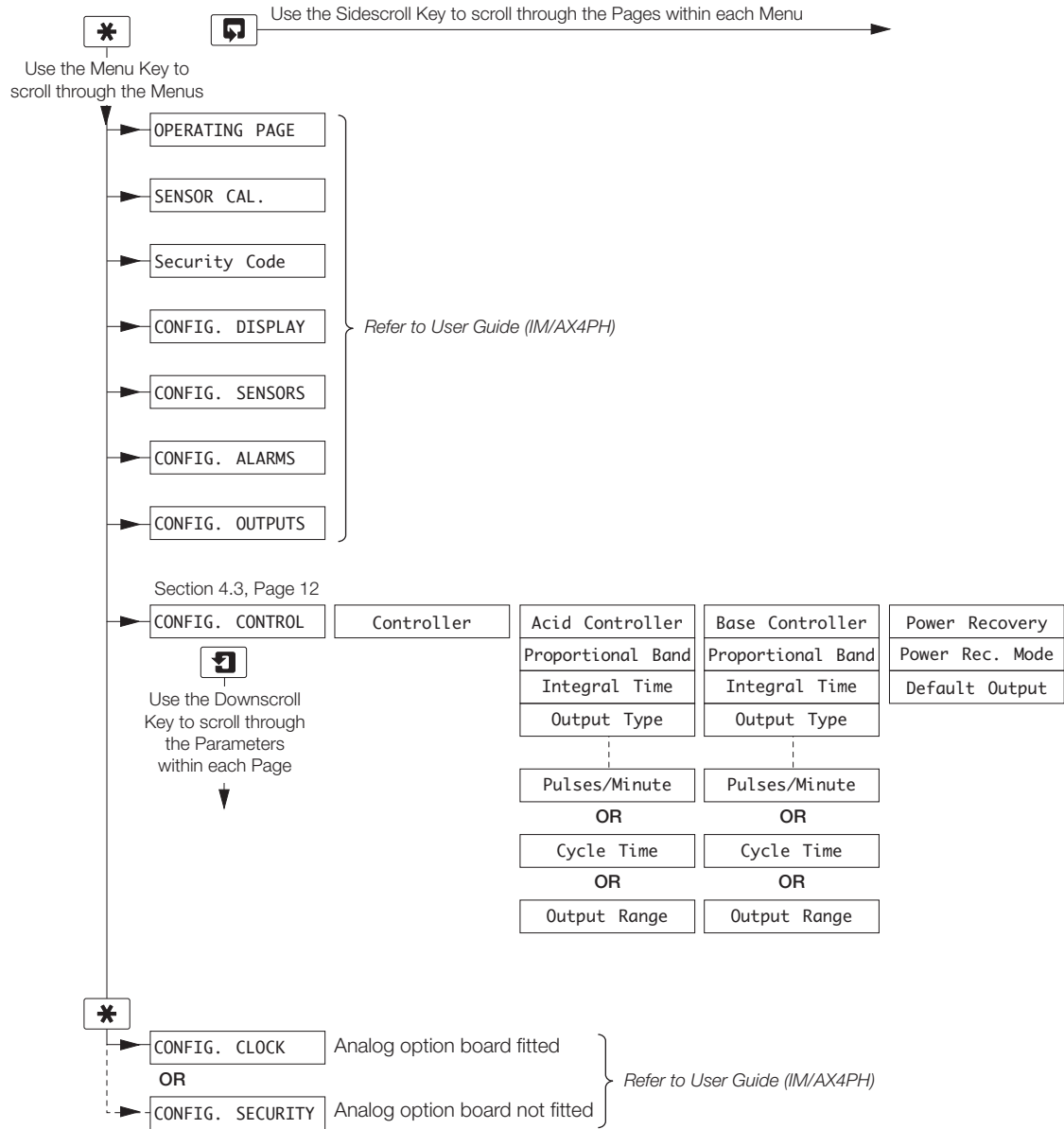
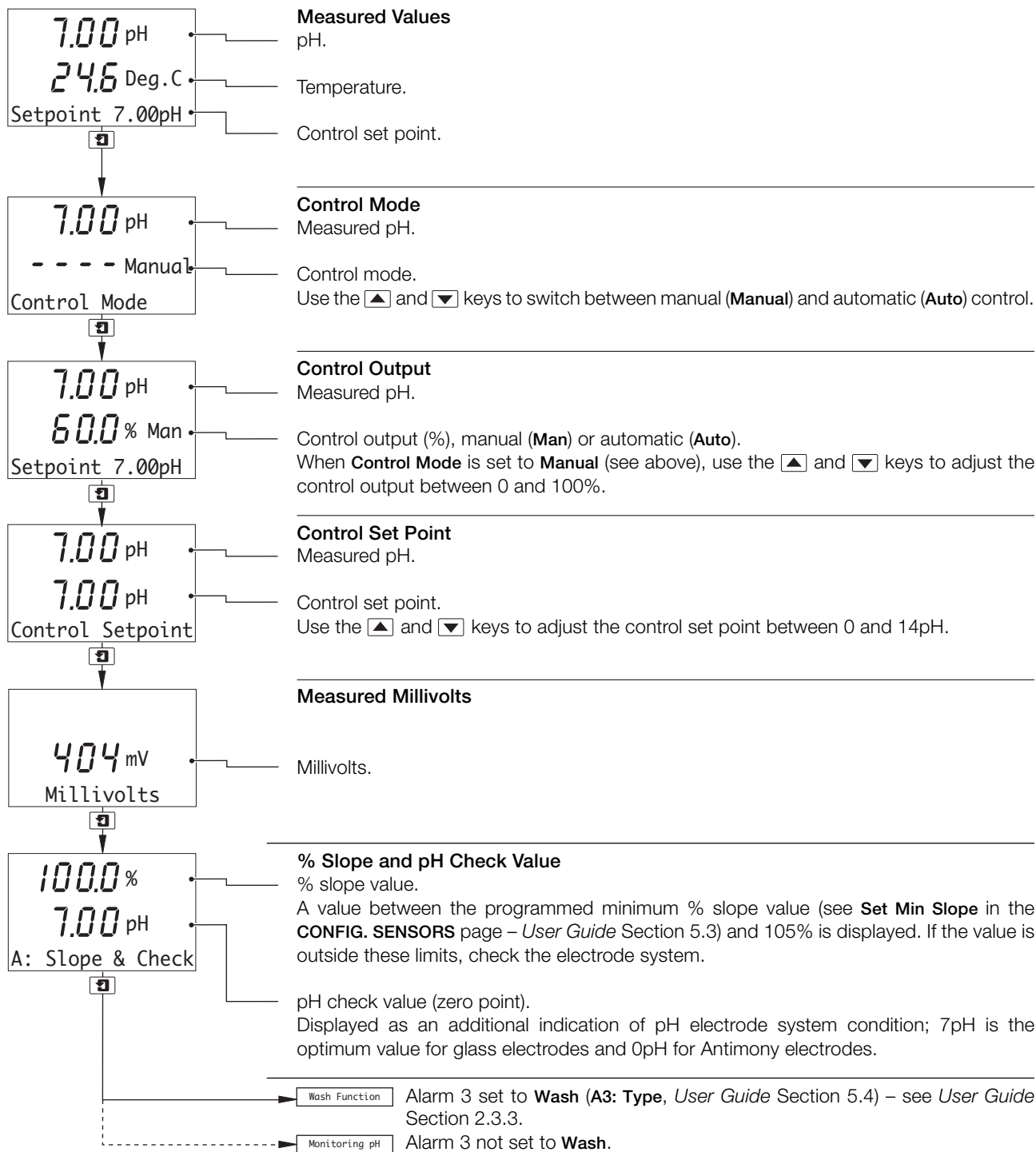

Fig. 2.2 Overall Programming Chart – Dual (Bi-directional) PI Controller

2.2 Operating Page

2.2.1 Single PID Controller

Note. The Single PID Controller operating page replaces the Single Input pH operating page shown in Section 2.3.1 of the *User Guide*, IM/AX4PH.



...2 OPERATION

...2.2 Operating Page

2.2.2 Dual (Bi-directional) PI Controller

Note. The Dual (Bi-directional) PI Controller operating page replaces the Single Input pH operating page shown in Section 2.3.1 of the *User Guide*, IM/AX4PH.

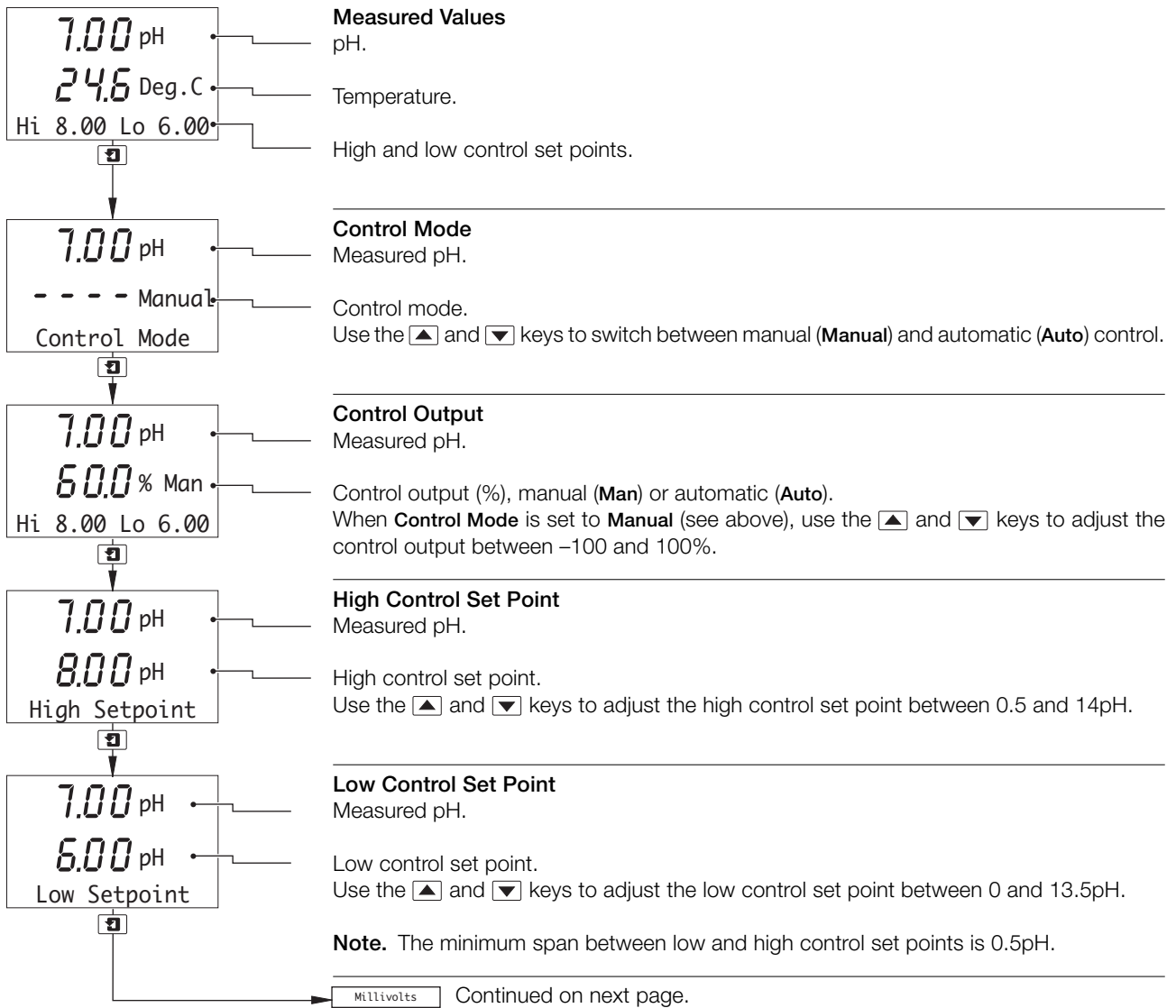

...2.2 Operating Page

...2.2.2 Dual (Bi-directional) PI Controller

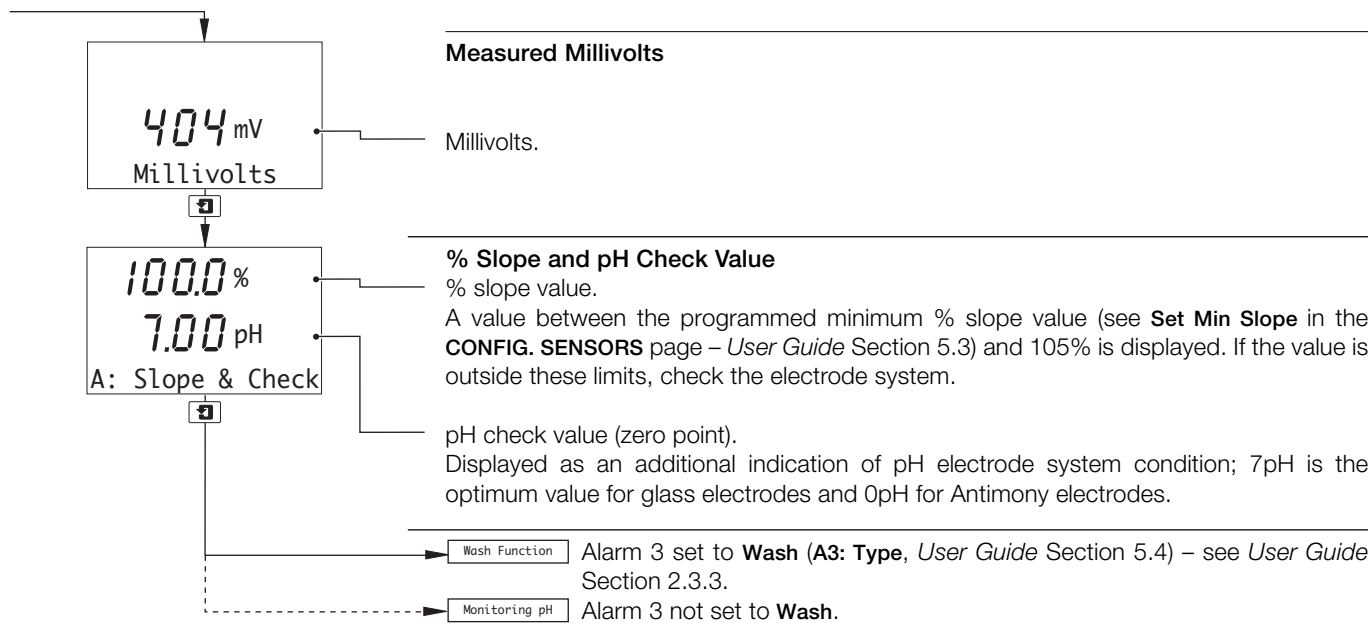

3 OPERATOR VIEWS

3.1 View Set Points

Notes.

- The View Set Points page replaces the View Set Points page shown in Section 3.1 of the *User Guide*, IM/AX4PH.
- The parameter names and units of measurement displayed in the View Set Points page depend on the Probe Type setting for Sensor A in the **CONFIG. SENSORS** page – see *User Guide*, Section 5.3. Those shown below are given as examples only.

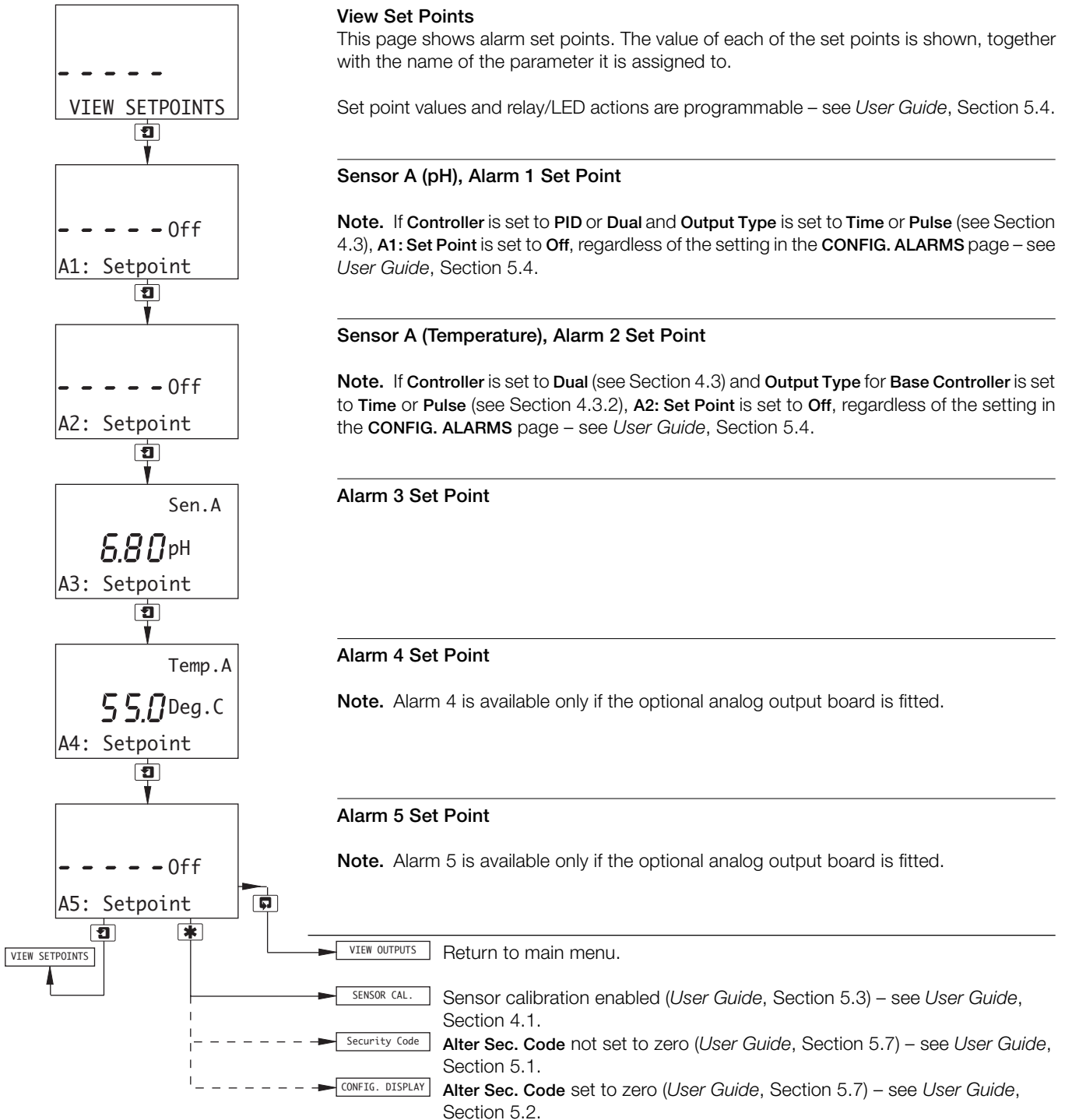

View Set Points

This page shows alarm set points. The value of each of the set points is shown, together with the name of the parameter it is assigned to.

Set point values and relay/LED actions are programmable – see *User Guide*, Section 5.4.

Sensor A (pH), Alarm 1 Set Point

Note. If **Controller** is set to **PID** or **Dual** and **Output Type** is set to **Time** or **Pulse** (see Section 4.3), **A1: Set Point** is set to **Off**, regardless of the setting in the **CONFIG. ALARMS** page – see *User Guide*, Section 5.4.

Sensor A (Temperature), Alarm 2 Set Point

Note. If **Controller** is set to **Dual** (see Section 4.3) and **Output Type** for **Base Controller** is set to **Time** or **Pulse** (see Section 4.3.2), **A2: Set Point** is set to **Off**, regardless of the setting in the **CONFIG. ALARMS** page – see *User Guide*, Section 5.4.

Alarm 3 Set Point

Alarm 4 Set Point

Note. Alarm 4 is available only if the optional analog output board is fitted.

Alarm 5 Set Point

Note. Alarm 5 is available only if the optional analog output board is fitted.

4 PROGRAMMING

4.1 Setting Up Three Term (PID) Control Parameters

To enable a process to be controlled satisfactorily, the following conditions must apply:

- The process must be capable of reaching a natural balance with a steady load.
- It must be possible to introduce small changes into the system without destroying either the process or the product.

The **Proportional Band** determines the gain of the system. (the gain is the reciprocal of the proportional band setting, e.g. a setting of 20% is equivalent to a gain of 5). If the proportional band is too narrow, the control loop may become unstable and cause the system to oscillate. With proportional band control only, the system normally stabilizes eventually but at a value which is offset from the set point.

The addition of **Integral Action Time** removes the offset but, if set too short, can cause the system to go into oscillation. The introduction of **Derivative Action Time** reduces the time required by the process to stabilize.

4.2 Manual Tuning

Before starting up a new process or changing an existing one:

- Select the **Configure Control** page and ensure that **Controller** is set to **PID** – see Section 4.3.
- Select the **PID Controller** page and set the following:

Proportional Band	– 100%	} – see Section 4.3.1
Integral Time	– 0 (off)	
Derivative Time	– 0 (off)	

Note. If the system goes into oscillation with increasing amplitude (Fig. 4.1 Mode B), reset the proportional band to 200%. If oscillation continues as in Mode B, increase the proportional band further until the system ceases to oscillate.

If the system oscillates as in Fig. 4.1 Mode A, or does not oscillate, refer to step c).

- Reduce the **Proportional Band** by 20% increments and observe the response. Continue until the process cycles continuously without reaching a stable condition (i.e. a sustained oscillation with constant amplitude as shown in Mode C). This is the critical point.
- Note the cycle time 't' (Fig. 4.1 Mode C) and the **Proportional Band** (critical value) setting.
- Set **Proportional Band** to:
 - 1.6 times the critical value (for P+D or P+I+D control)
 - 2.2 times the critical value (for P+I control)
 - 2.0 times the critical value (for P only control)
- Set **Integral Time** to:

$$\frac{t}{2} \text{ (for P+I+D control)}$$

$$\frac{t}{1.2} \text{ (for P+D control)}$$

- Set **Derivative Time** to:

$$\frac{t}{8} \text{ (for P+I+D control)}$$

$$\frac{t}{12} \text{ (for P+D control)}$$

The analyzer is now ready for fine tuning by small adjustments to the P, I and D terms, after the introduction of a small disturbance of the set point.

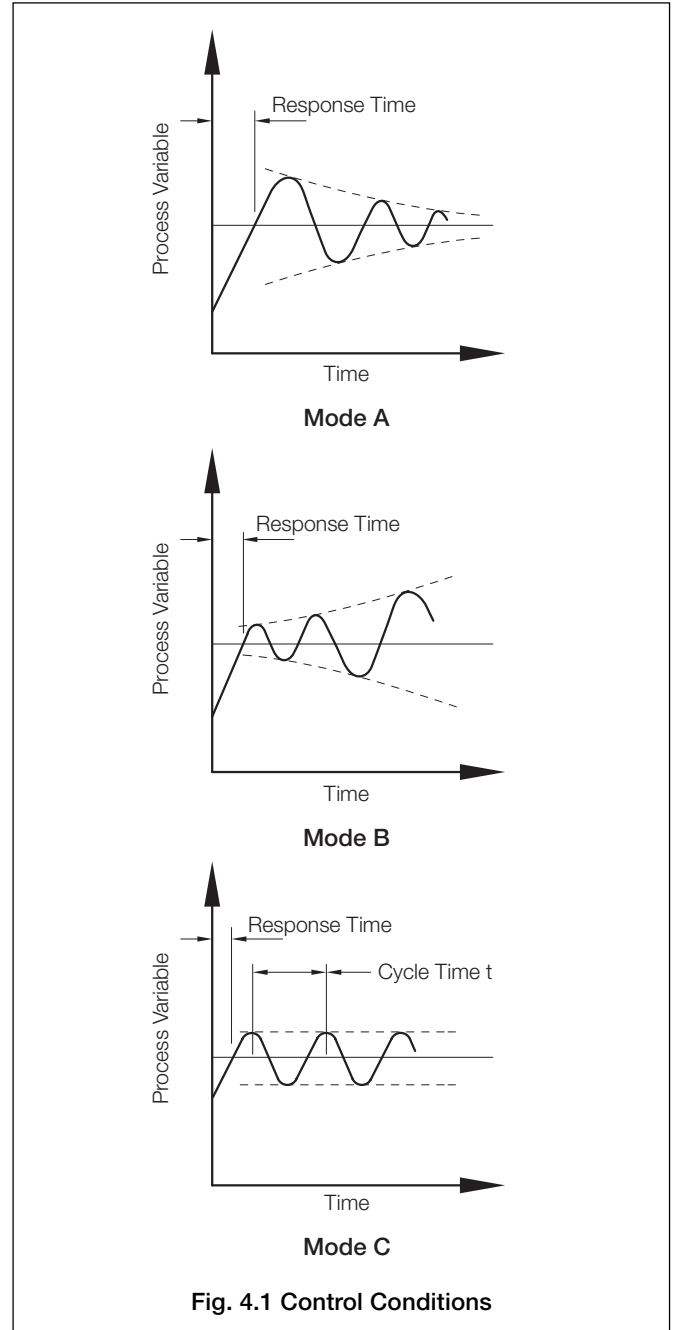

4.3 Configure Control

Note. Applicable only if **A: Probe Type** is set to **pH** – see *User Guide*, Section 5.3.

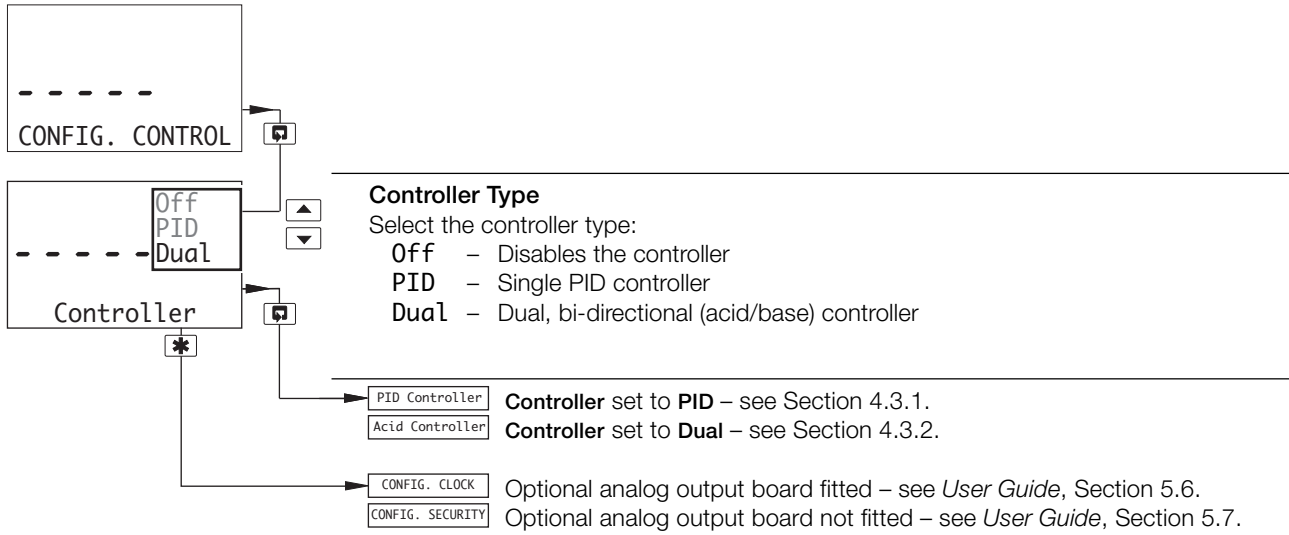

...4.3 Configure Control

4.3.1 Configure Single PID Controller

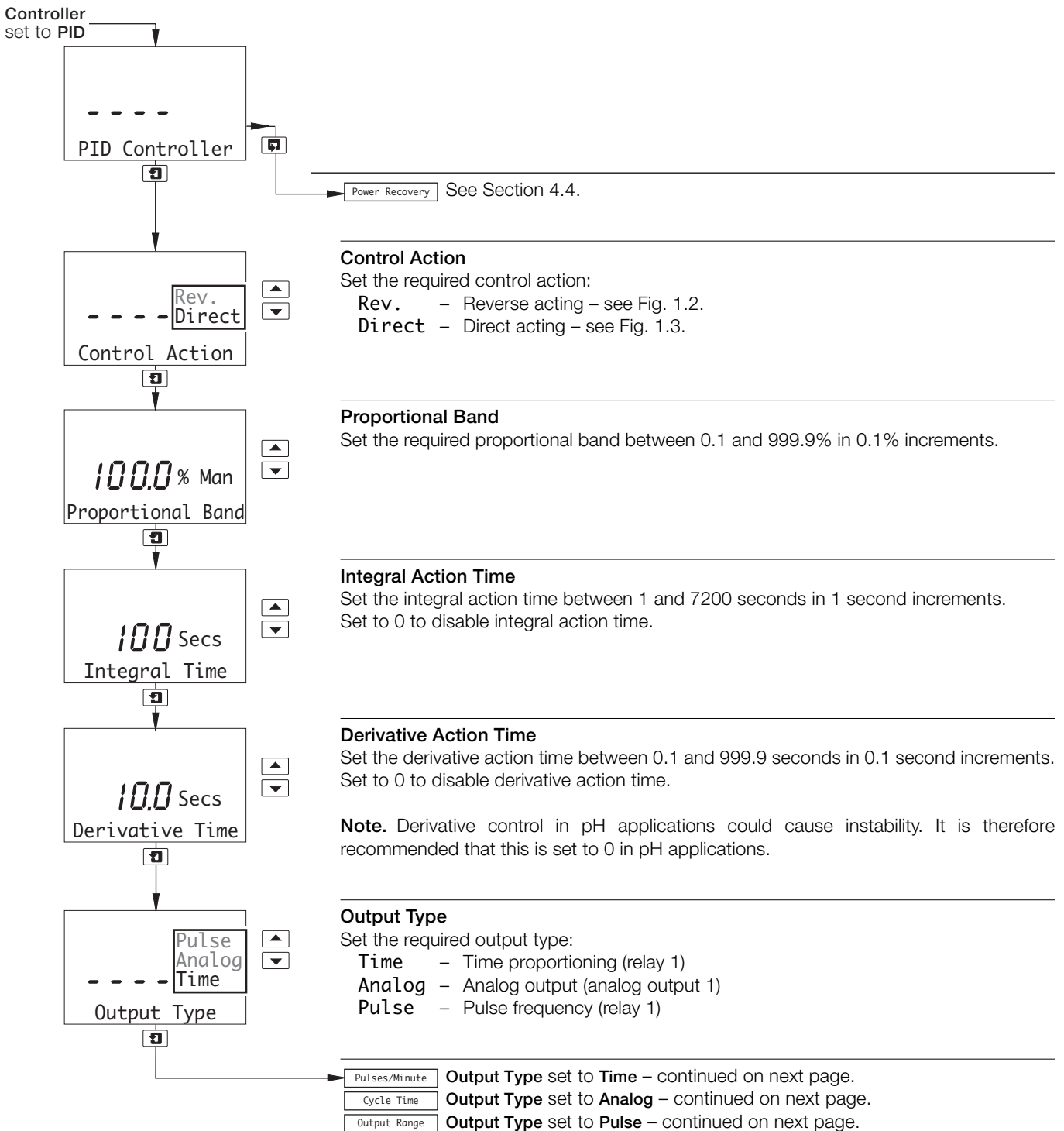

...4.3 Configure Control

...4.3.1 Configure Single PID Controller

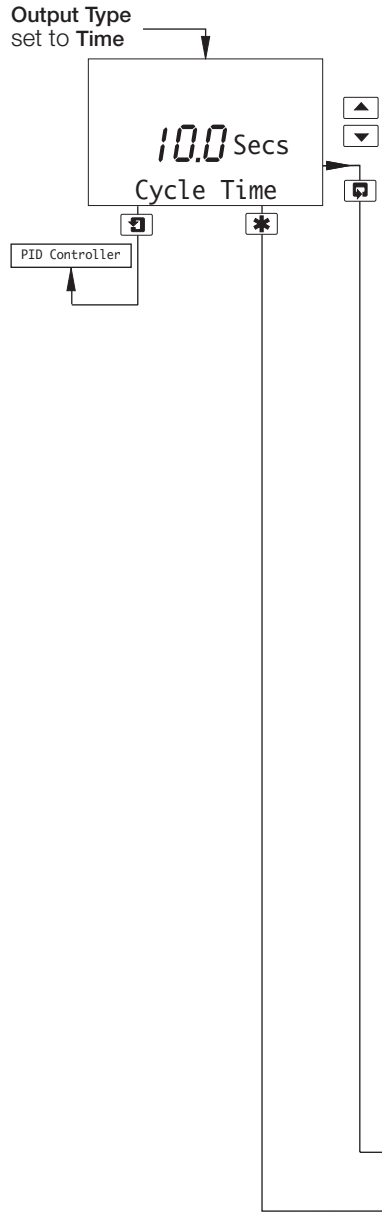

Time Proportioning Output

The Time Proportioning Output is interrelated to the retention time of the vessel and the flow of the chemical reagent and is adjusted experimentally to ensure that the chemical reagent is adequate to control the dosing under maximum loading. It is recommended that the Time Proportioning Output is adjusted in Manual Mode set to 100% valve output before setting up the PID parameters.

The time proportioning output value is calculated using the following equation:

$$\text{on time} = \frac{\text{control output} \times \text{cycle time}}{100}$$

Set the cycle time, between 1.0 and 300.0 seconds in 0.1 second increments – see Appendix B, Fig. B4 Mode C.

Note. Changes to the cycle time do not take effect until the start of a new cycle.

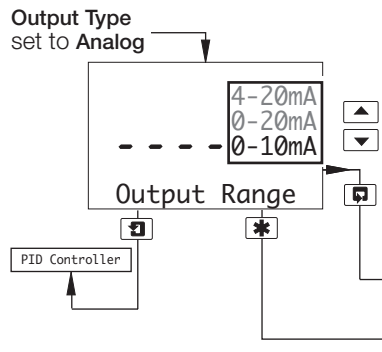
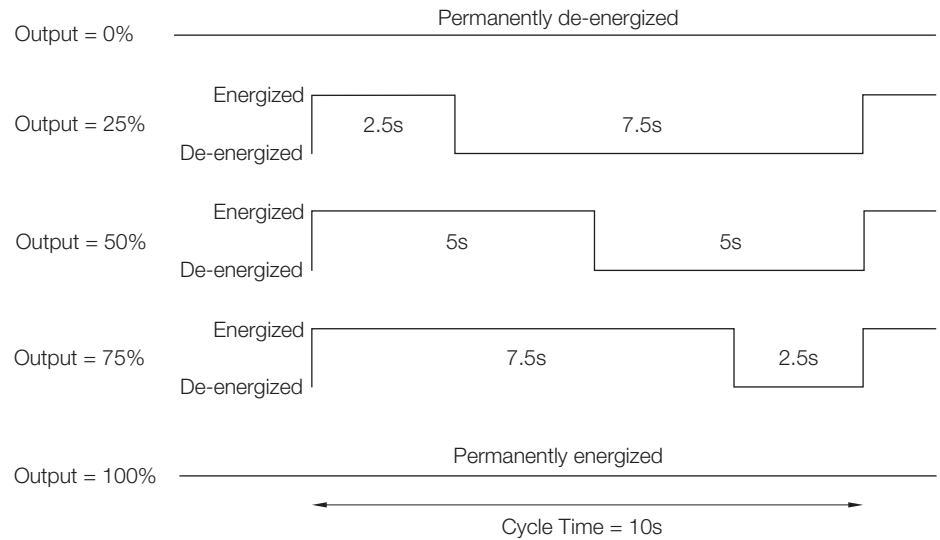

Analog Output

Set the analog current output range.

...4.3 Configure Control

...4.3.1 Configure Single PID Controller

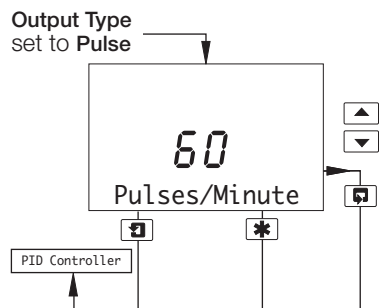

Pulse Frequency Output

The pulse frequency output is the number of relay pulses per minute required for 100% control output. The Pulse Frequency Output is interrelated to the chemical reagent strength and the solution flow rate. The chemical reagent flowrate and pulse frequency is adjusted experimentally to ensure that the chemical reagent is adequate to control the dosing under maximum loading. Adjust the Pulse Frequency Output in Manual Mode and set to 100% valve output before setting up the PID parameters.

For example, if the observed value on the display is 6 and the control point is 5 then the frequency needs to be increased.

The actual number of pulses per minute is calculated using the following equation:

$$\text{Actual pulses per minute} = \frac{\% \text{ control output} \times \text{pulse frequency output}}{100}$$

Set the pulse frequency between 1 and 120 pulses per minute in 1 pulse per minute increments.

Control Output	Pulse Frequency Output/Minute			
	1	10	50	120
0	0	0	0	0
25	0.25	2.5	12.5	30
50	0.50	5.0	25	60
75	0.75	7.5	37.5	90
100	1.00	10.0	50	120

Note. If the pulse frequency of 120 is reached then concentration of the reagent needs to be increased.

Note. Changes to the pulse frequency do not take effect until the start of a new cycle.

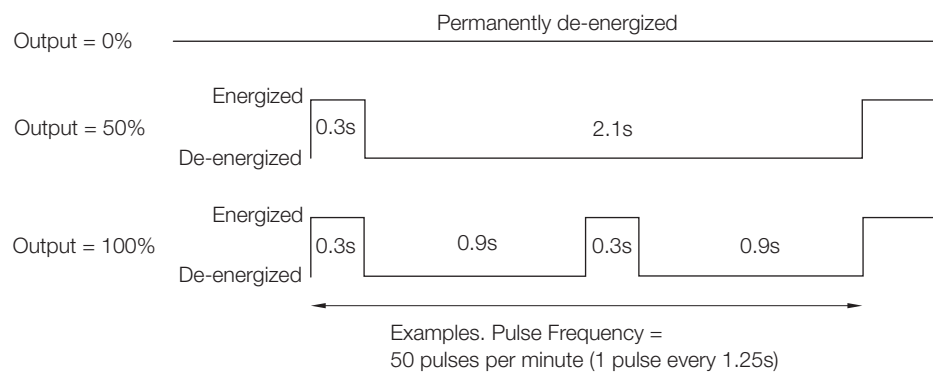

Power Recovery See Section 5.8.2.

CONFIG. SECURITY See Section 5.9.

...4.3 Configure Control

4.3.2 Configure Dual (Bi-directional) PI Controller

Controller
set to Dual

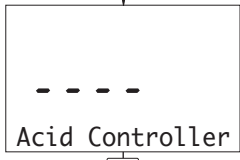

Base Controller See page 18.

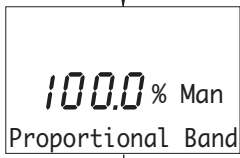

Proportional Band

Set the required proportional band between 0.1 and 999.9% in 0.1% increments.

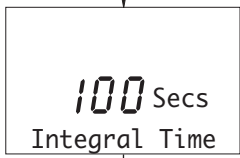

Integral Time

Set the integral action time between 1 and 7200 seconds in 1 second increments.
Set to 0 to disable integral action time.

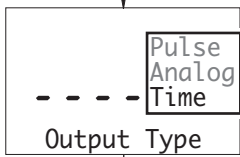

Output Type

Set the required output type:

- Time** - Time proportioning (relay 1)
- Analog** - Analog output (analog output 1)
- Pulse** - Pulse frequency (relay 1)



- Cycle Time **Output Type set to Time** – see next page.
- Output Range **Output Type set to Analog** – see next page.
- Pulses/Minute **Output Type set to Pulse** – see next page.

...4.3 Configure Control

...4.3.2 Configure Dual (Bi-directional) PI Controller

Output Type
set to Time

Time Proportioning Output
Set the cycle time between 1.0 and 300.0 seconds in 0.1 second increments.

Note. See also Section 4.3.1 page 14.

Acid Controller

Base Controller See next page.

CONFIG. CLOCK Optional analog output board fitted – see *User Guide*, Section 5.6.
CONFIG. SECURITY Optional analog output board not fitted – see *User Guide*, Section 5.7.

Output Type
set to Analog

Analog Output
Set the analog current output range.

Acid Controller

Base Controller See next page.

CONFIG. CLOCK Optional analog output board fitted – see *User Guide*, Section 5.6.
CONFIG. SECURITY Optional analog output board not fitted – see *User Guide*, Section 5.7.

Output Type
set to Pulse

Pulse Frequency Output
Set the pulse frequency between 1 and 120 pulses per minute in 1 pulse per minute increments.

Note. See also Section 4.3.1 page 15.

Acid Controller

Base Controller See next page.

CONFIG. CLOCK Optional analog output board fitted – see *User Guide*, Section 5.6.
CONFIG. SECURITY Optional analog output board not fitted – see *User Guide*, Section 5.7.

...4 PROGRAMMING

...4.3 Configure Control

...4.3.2 Configure Dual (Bi-directional) PI Controller

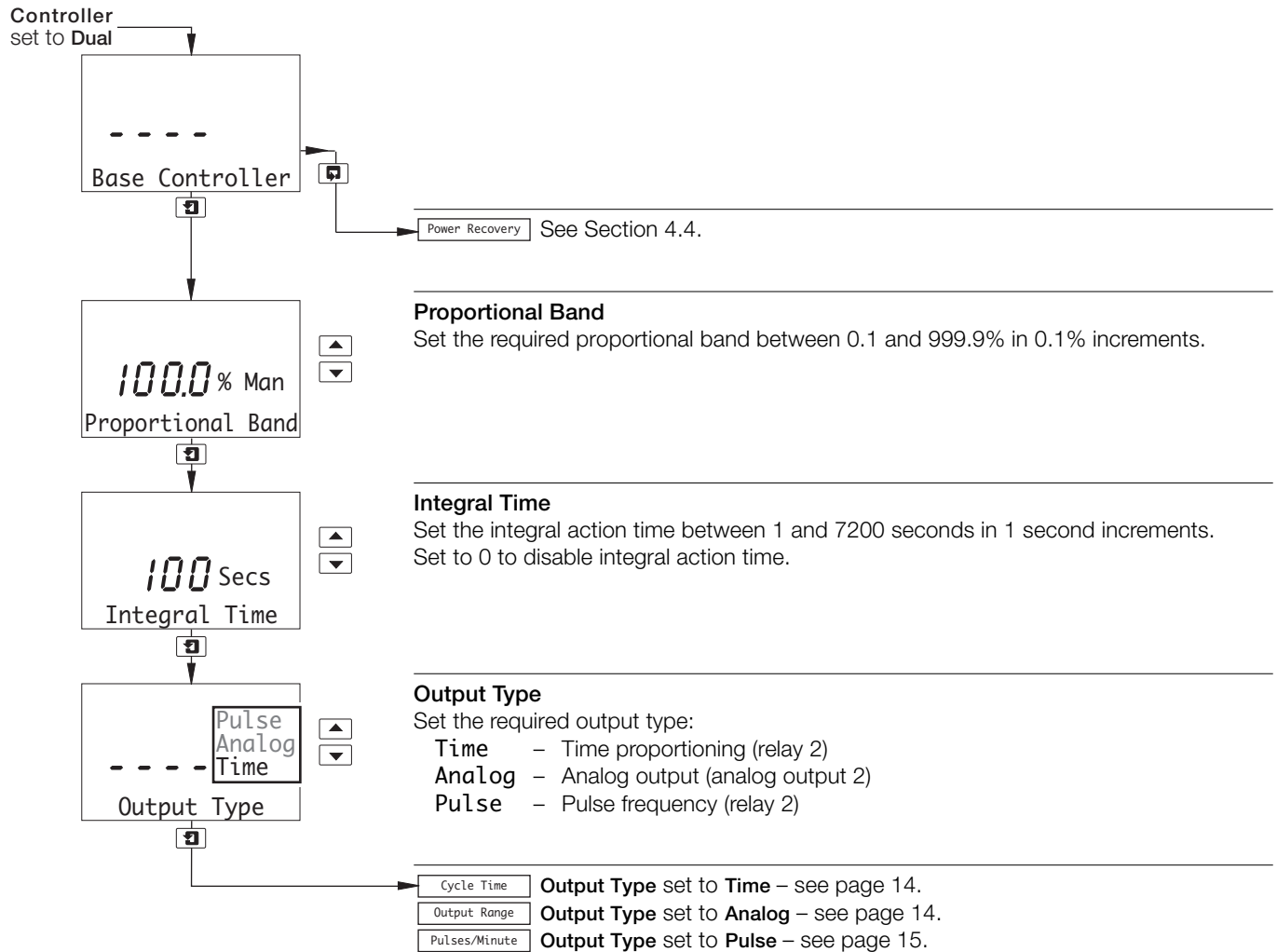

4.4 Configure Power Failure Recovery Mode

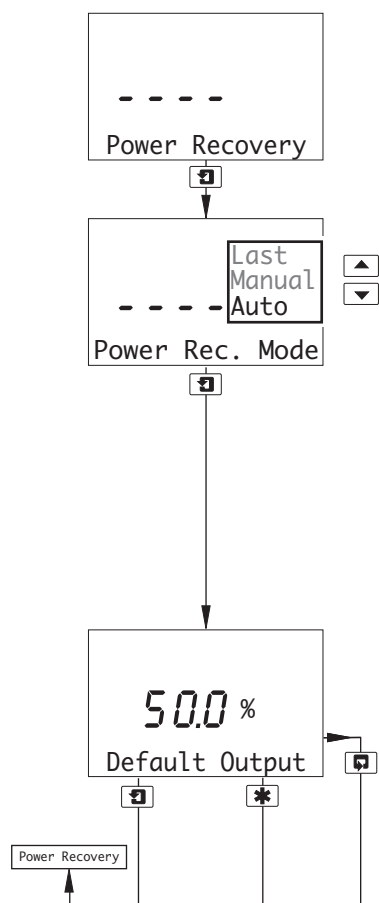
**Power Failure Recovery Mode**

When power to the analyzer is restored, **Control Mode** (see Section 2.2) is set automatically according to the chosen Power Failure Recovery Mode.

Set the required mode:

- Auto** – **Control Mode** is set to **Auto** irrespective of its setting prior to the power failure.
- Manual** – **Control Mode** is set to **Manual** irrespective of its setting prior to the power failure. **Control Output** (see Section 2.2) is set to the level set in the **Default Output** frame below.
- Last** – **Control Mode** and **Control Output** are set to the same state as that set prior to the power failure.

Default Output

If **Controller** is set to **PID** (see Section 4.3), set the default output required between 0 and 100% in 0.1% increments.

If **Controller** is set to **Dual** (see Section 4.3), set the default output required between –100 and 100% in 0.1% increments.

Notes.

- A setting of 1 to 100% represents a direct output.
- A setting of –1 to –100% represents a reverse output.
- A setting of 0% represents no output i.e. both direct and reverse outputs are switched off.

CONFIG. CONTROL Return to main menu.

CONFIG. CLOCK Optional analog output board fitted – see *User Guide*, Section 5.6.

CONFIG. SECURITY Optional analog output board not fitted – see *User Guide*, Section 5.7.

NOTES

PRODUCTS & CUSTOMER SUPPORT

Products

Automation Systems

- *for the following industries:*
 - Chemical & Pharmaceutical
 - Food & Beverage
 - Manufacturing
 - Metals and Minerals
 - Oil, Gas & Petrochemical
 - Pulp and Paper

Drives and Motors

- *AC and DC Drives, AC and DC Machines, AC Motors to 1kV*
- *Drive Systems*
- *Force Measurement*
- *Servo Drives*

Controllers & Recorders

- *Single and Multi-loop Controllers*
- *Circular Chart and Strip Chart Recorders*
- *Paperless Recorders*
- *Process Indicators*

Flexible Automation

- *Industrial Robots and Robot Systems*

Flow Measurement

- *Electromagnetic Magnetic Flowmeters*
- *Mass Flowmeters*
- *Turbine Flowmeters*
- *Flow Elements*

Marine Systems & Turbochargers

- *Electrical Systems*
- *Marine Equipment*
- *Offshore Retrofit and Refurbishment*

Process Analytics

- *Process Gas Analysis*
- *Systems Integration*

Transmitters

- *Pressure*
- *Temperature*
- *Level*
- *Interface Modules*

Valves, Actuators and Positioners

- *Control Valves*
- *Actuators*
- *Positioners*

Water, Gas & Industrial Analytics Instrumentation

- *pH, Conductivity and Dissolved Oxygen Transmitters and Sensors*
- *Ammonia, Nitrate, Phosphate, Silica, Sodium, Chloride, Fluoride, Dissolved Oxygen and Hydrazine Analyzers.*
- *Zirconia Oxygen Analyzers, Katharometers, Hydrogen Purity and Purge-Gas Monitors, Thermal Conductivity.*

Customer Support

We provide a comprehensive after sales service via a Worldwide Service Organization. Contact one of the following offices for details on your nearest Service and Repair Centre.

United Kingdom

ABB Limited
Tel: +44 (0)1453 826661
Fax: +44 (0)1453 829671

United States of America

ABB Inc.
Tel: +1 (0) 775 850 4800
Fax: +1 (0) 775 850 4808

Client Warranty

Prior to installation, the equipment referred to in this manual must be stored in a clean, dry environment, in accordance with the Company's published specification.

Periodic checks must be made on the equipment's condition. In the event of a failure under warranty, the following documentation must be provided as substantiation:

1. A listing evidencing process operation and alarm logs at time of failure.
2. Copies of all storage, installation, operating and maintenance records relating to the alleged faulty unit.

ABB has Sales & Customer Support
expertise in over 100 countries worldwide

www.abb.com

The Company's policy is one of continuous product
improvement and the right is reserved to modify the
information contained herein without notice.

Printed in UK (03.06)

© ABB 2006



ABB Limited
Oldends Lane, Stonehouse
Gloucestershire
GL10 3TA
UK
Tel: +44 (0)1453 826661
Fax: +44 (0)1453 829671

ABB Inc.
Analytical Instruments
9716 S. Virginia St., Ste. E
Reno, Nevada 89521
USA
Tel: +1 (0) 775 850 4800
Fax: +1 (0) 775 850 4808