

# AX418, AX438, AX480, AX468 and AX488

## Single and dual input analyzers for dissolved oxygen



# The Company

We are an established world force in the design and manufacture of measurement products for industrial process control, flow measurement, gas and liquid analysis and environmental applications.

As a part of ABB, a world leader in process automation technology, we offer customers application expertise, service and support worldwide.

We are committed to teamwork, high quality manufacturing, advanced technology and unrivalled service and support.

The quality, accuracy and performance of the Company's products result from over 100 years experience, combined with a continuous program of innovative design and development to incorporate the latest technology.

EN ISO 9001:2000



Cert. No. Q 05907

EN 29001 (ISO 9001)



Lenno, Italy – Cert. No. 9/90A

Stonehouse, U.K.



## Electrical Safety

This equipment complies with the requirements of CEI/IEC 61010-1:2001-2 'Safety Requirements for Electrical Equipment for Measurement, Control and Laboratory Use'. If the equipment is used in a manner NOT specified by the Company, the protection provided by the equipment may be impaired.

## Symbols

One or more of the following symbols may appear on the equipment labelling:

	<b>Warning</b> – Refer to the manual for instructions
	<b>Caution</b> – Risk of electric shock
	Protective earth (ground) terminal
	Earth (ground) terminal

	Direct current supply only
	Alternating current supply only
	Both direct and alternating current supply
	The equipment is protected through double insulation

Information in this manual is intended only to assist our customers in the efficient operation of our equipment. Use of this manual for any other purpose is specifically prohibited and its contents are not to be reproduced in full or part without prior approval of the Technical Publications Department.

### Health and Safety

To ensure that our products are safe and without risk to health, the following points must be noted:

1. The relevant sections of these instructions must be read carefully before proceeding.
2. Warning labels on containers and packages must be observed.
3. Installation, operation, maintenance and servicing must only be carried out by suitably trained personnel and in accordance with the information given.
4. Normal safety precautions must be taken to avoid the possibility of an accident occurring when operating in conditions of high pressure and/or temperature.
5. Chemicals must be stored away from heat, protected from temperature extremes and powders kept dry. Normal safe handling procedures must be used.
6. When disposing of chemicals ensure that no two chemicals are mixed.

Safety advice concerning the use of the equipment described in this manual or any relevant hazard data sheets (where applicable) may be obtained from the Company address on the back cover, together with servicing and spares information.

# CONTENTS

Section	Page	Section	Page
<b>1 INTRODUCTION</b> .....	<b>2</b>	<b>6 INSTALLATION</b> .....	<b>39</b>
1.1 System Description .....	2	6.1 Siting Requirements .....	39
1.2 PID Control .....	2	6.2 Mounting .....	40
1.3 AX400 Series Analyzer Options .....	2	6.2.1 Wall-/Pipe-mount Analyzers .....	40
<b>2 OPERATION</b> .....	<b>3</b>	6.2.2 Panel-mount Analyzers .....	41
2.1 Powering Up the Analyzer .....	3	6.3 Electrical Connections .....	42
2.2 Displays and Controls .....	3	6.3.1 Relay Contact Protection and Interference Suppression .....	43
2.2.1 Membrane Key Functions .....	3	6.3.2 Cable Entry Knockouts, Wall-/Pipe-mount Analyzer .....	44
2.3 Operating Page .....	6	6.4 Wall-/Pipe-mount Analyzer Connections .....	45
2.3.1 Single Input Dissolved Oxygen .....	6	6.4.1 Access to Terminals .....	45
2.3.2 Dual Input Dissolved Oxygen .....	7	6.4.2 Connections .....	46
2.3.3 Wash Function .....	8	6.5 Panel-mount Analyzer Connections .....	47
<b>3 OPERATOR VIEWS</b> .....	<b>9</b>	6.5.1 Access to Terminals .....	47
3.1 View Set Points .....	9	6.5.2 Connections .....	48
3.2 View Outputs .....	10	<b>7 CALIBRATION</b> .....	<b>49</b>
3.3 View Hardware .....	10	7.1 Equipment Required .....	49
3.4 View Software .....	11	7.2 Preparation .....	49
3.5 View Logbook .....	11	7.3 Factory Settings .....	50
3.6 View Clock .....	14	<b>8 SIMPLE FAULT FINDING</b> .....	<b>55</b>
<b>4 SETUP</b> .....	<b>15</b>	8.1 Error Messages .....	55
4.1 Sensor Calibration .....	15	8.2 No Response to DO Changes .....	55
<b>5 PROGRAMMING</b> .....	<b>20</b>	8.3 Checking the Temperature Input .....	55
5.1 Security Code .....	20	<b>SPECIFICATION</b> .....	<b>56</b>
5.2 Configure Display .....	21	<b>APPENDIX A</b> .....	<b>59</b>
5.3 Configure Sensors .....	22	A1 Oxygen Solubility in Pure Water .....	59
5.4 Configure Alarms .....	23	A2 Correction for Salinity .....	59
5.4.1 Wash Cycle Configuration (applicable only to Alarm 3) .....	26	A3 DO Calibration .....	60
5.5 Configure Outputs .....	28	A3.1 Zero Calibration .....	60
5.6 Configure Clock .....	30	A3.2 Span Calibration .....	60
5.7 Configure Control .....	31	<b>APPENDIX B</b> .....	<b>61</b>
5.7.1 Configure Single PID Controller .....	32	B1 Single PID Controller .....	61
5.7.2 Configure Power Failure Recovery Mode .....	35	B1.1 Reverse Acting Single PID Control .....	61
5.8 Configure Security .....	36	B1.2 Direct Acting Single PID Control .....	62
5.9 Configure Logbook .....	36	B2 Output Assignment .....	62
5.10 Test Outputs and Maintenance .....	37	B3 Setting Up Three Term (PID) Control Parameters .....	63
		B4 Manual Tuning .....	63

# 1 INTRODUCTION

## 1.1 System Description

The AX480 Single Input and AX488 Dual Input Dissolved Oxygen (DO) analyzers and associated sensors have been designed for continuous monitoring and control in a wide range of applications including aeration in sewage treatment and river/effluent monitoring. The sensor can be standardized to the instrument using the built-in calibration facility.

The analyzers are available in wall-/pipe-mount or panel-mount versions with either one or two programmable DO input channels, each with its own associated temperature input channels. When making temperature compensated measurements, the sample temperature is sensed by a Pt100 resistance thermometer mounted in the sensor.

All models incorporate a wash facility for system cleaning; the alarm 3 relay can be configured to control the wash system either automatically or manually. The relay can be configured to deliver either a continuous or pulsed signal to control an external power supply to a solenoid or pump and the frequency, duration and recovery time of the wash cycle are also programmable. During a wash cycle, the analog output value is held in its pre-cycle condition.

Analyzer operation and programming are performed using five tactile membrane keys on the front panel. Programmed functions are protected from unauthorized alteration by a four-digit security code.

## 1.2 PID Control – AX480 Analyzer Only

The AX480 single input dissolved oxygen analyzer incorporates Proportional Integral Derivative (PID) control as standard. For a full description of PID control, refer to Appendix B.

## 1.3 AX400 Series Analyzer Options

Table 1.1 shows the range of configurations that are possible for the AX400 Series analyzers. The analyzer detects the type of input board fitted for each input automatically and displays only the operating and programming frames applicable to that input board type. If no input board is fitted for a second input (Sensor B), Sensor B frames are not displayed.

Model	Analyzer Description	Sensor A	Sensor B
AX410	Single Input 2-Electrode Conductivity (0 to 10,000 $\mu$ S/cm)	2-Electrode Conductivity	Not Applicable
AX411	Dual Input 2-Electrode Conductivity (0 to 10,000 $\mu$ S/cm)	2-Electrode Conductivity	2-Electrode Conductivity
AX413	Dual Input 2-Electrode Conductivity and 4-Electrode Conductivity	2-Electrode Conductivity	4-Electrode Conductivity
AX416	Dual Input 2-Electrode Conductivity and pH/Redox(ORP)	2-Electrode Conductivity	pH/Redox(ORP)
AX418	Dual Input 2-Electrode Conductivity and Dissolved Oxygen	2-Electrode Conductivity	Dissolved Oxygen
AX430	Single Input 4-Electrode Conductivity (0 to 2,000 mS/cm)	4-Electrode Conductivity	Not Applicable
AX433	Dual Input 4-Electrode Conductivity (0 to 2,000 mS/cm)	4-Electrode Conductivity	4-Electrode Conductivity
AX436	Dual Input 4-Electrode Conductivity and pH/Redox(ORP)	4-Electrode Conductivity	pH/Redox(ORP)
AX438	Dual Input 4-Electrode Conductivity and Dissolved Oxygen	4-Electrode Conductivity	Dissolved Oxygen
AX450	Single Input 2-Electrode Conductivity (USP)	2-Electrode Conductivity	Not Applicable
AX455	Dual Input 2-Electrode Conductivity (USP)	2-Electrode Conductivity	2-Electrode Conductivity
AX456	Dual Input 2-Electrode Conductivity (USP) and pH/Redox(ORP)	2-Electrode Conductivity	pH/Redox(ORP)
AX460	Single Input pH/Redox(ORP)	pH/Redox(ORP)	Not Applicable
AX466	Dual Input pH/Redox(ORP)	pH/Redox(ORP)	pH/Redox(ORP)
AX468	Dual Input pH/Redox(ORP) and Dissolved Oxygen	pH/Redox(ORP)	Dissolved Oxygen
AX480	Single Input Dissolved Oxygen	Dissolved Oxygen	Not Applicable
AX488	Dual Input Dissolved Oxygen	Dissolved Oxygen	Dissolved Oxygen

Table 1.1 AX400 Series Analyzer Options

## 2 OPERATION

### 2.1 Powering Up the Analyzer



**Warning.** Ensure all connections are made correctly, especially to the earth stud – see Section 6.3.

- 1) Ensure the input sensor(s) is/are connected correctly.
- 2) Switch on the power supply to the analyzer. A start-up screen is displayed while internal checks are performed, then the *Operating Page* (Section 2.3) is displayed as the dissolved oxygen monitoring operation starts.

### 2.2 Displays and Controls – Fig. 2.1

The display comprises two rows of 4½ digit, 7-segment digital displays, that show the actual values of the measured parameters and alarm set points, and a 6-character dot matrix display showing the associated units. The lower display line is a 16-character dot matrix display showing operating and programming information.

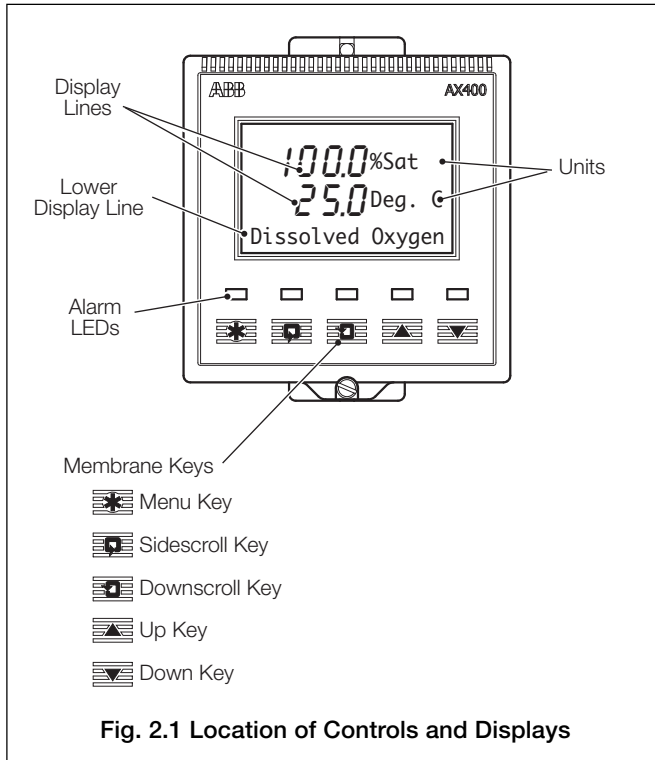

### 2.2.1 Membrane Key Functions – Fig. 2.2

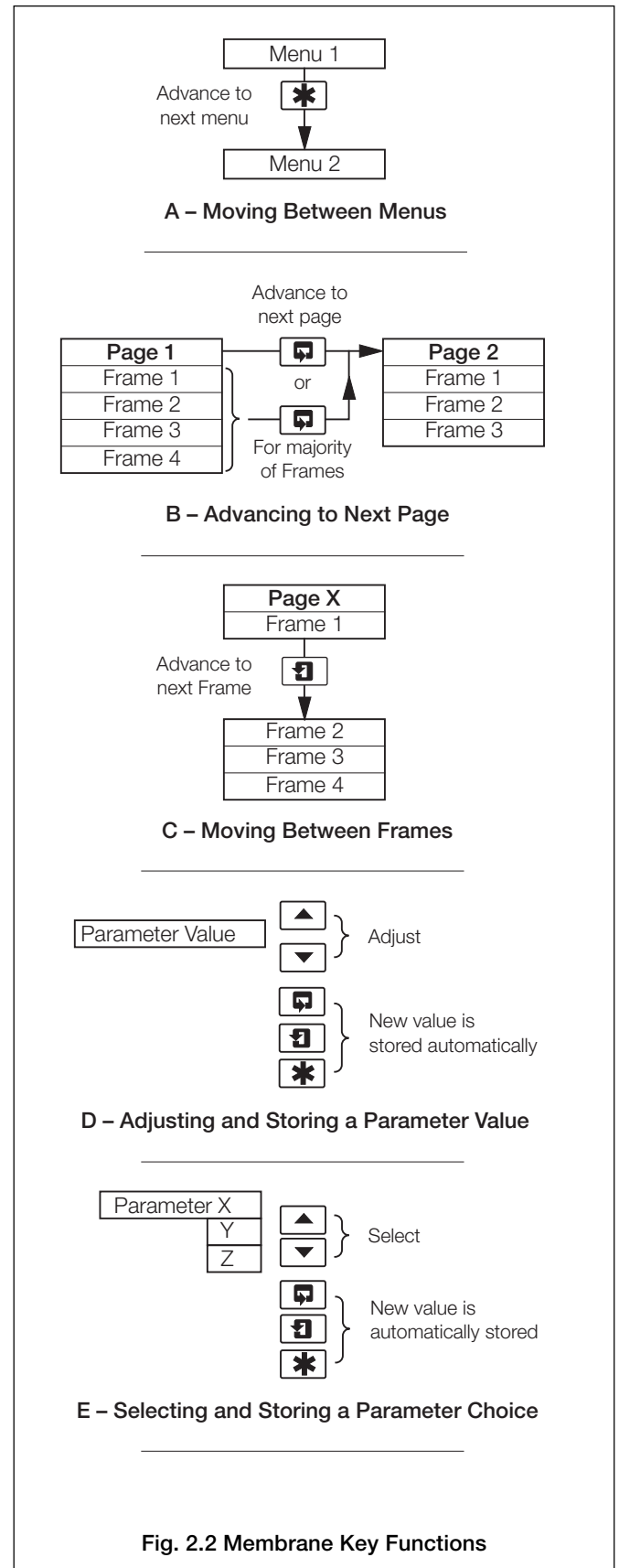

**Fig. 2.2 Membrane Key Functions**

## ...2 OPERATION

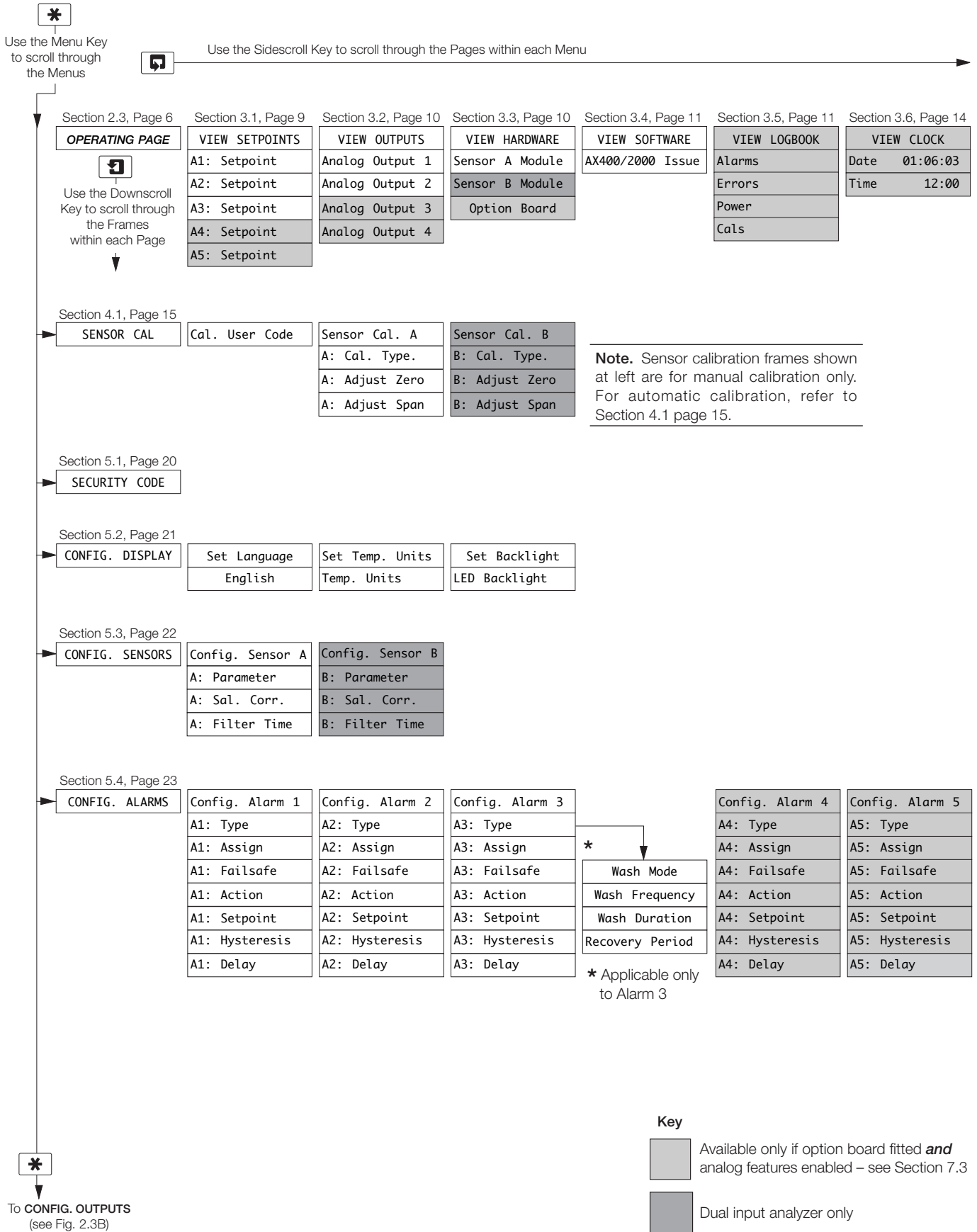

Fig. 2.3A Overall Programming Chart

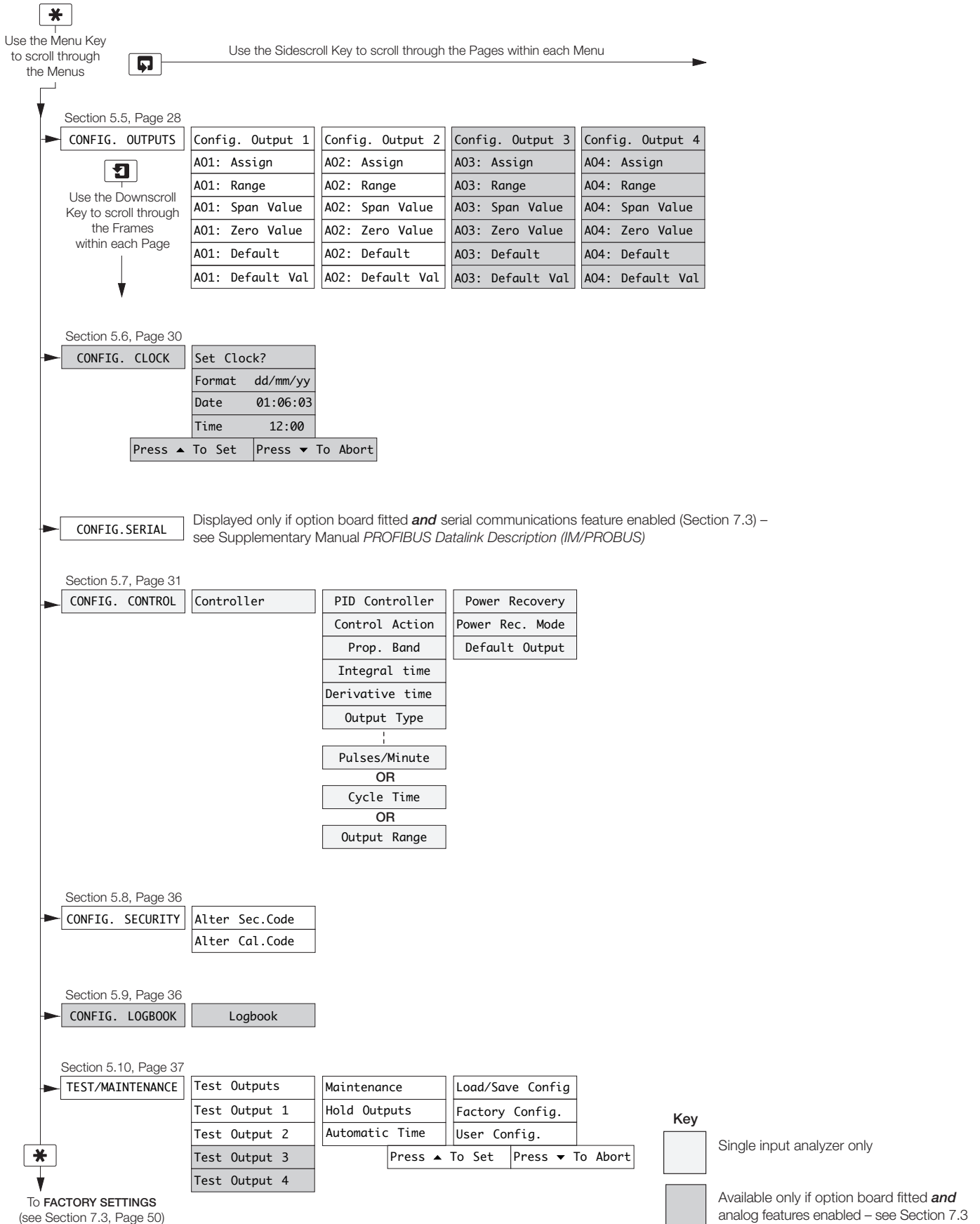
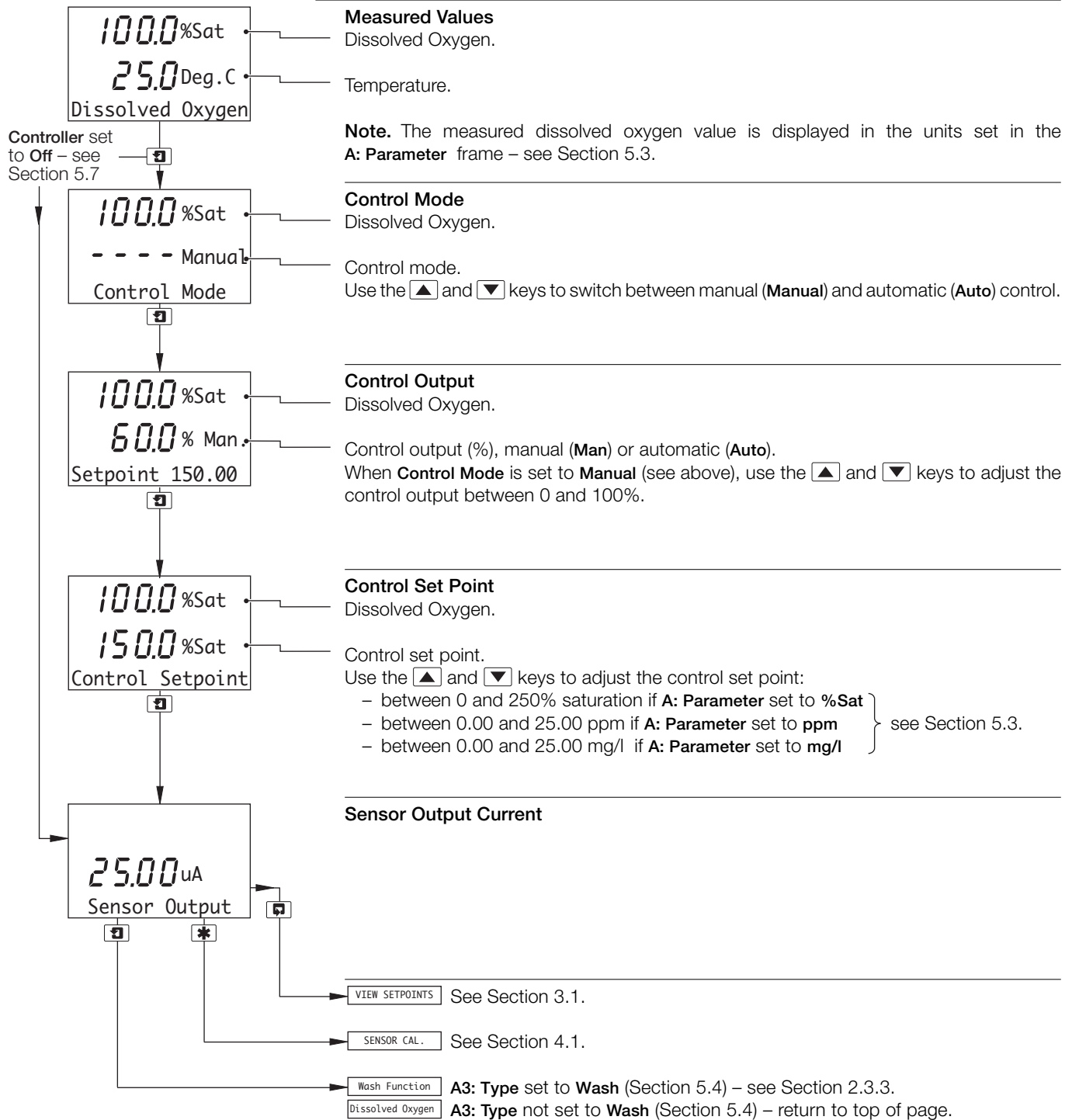

Fig. 2.3B Overall Programming Chart

2.3 Operating Page

2.3.1 Single Input Dissolved Oxygen



...2.3 Operating Page

2.3.2 Dual Input Dissolved Oxygen

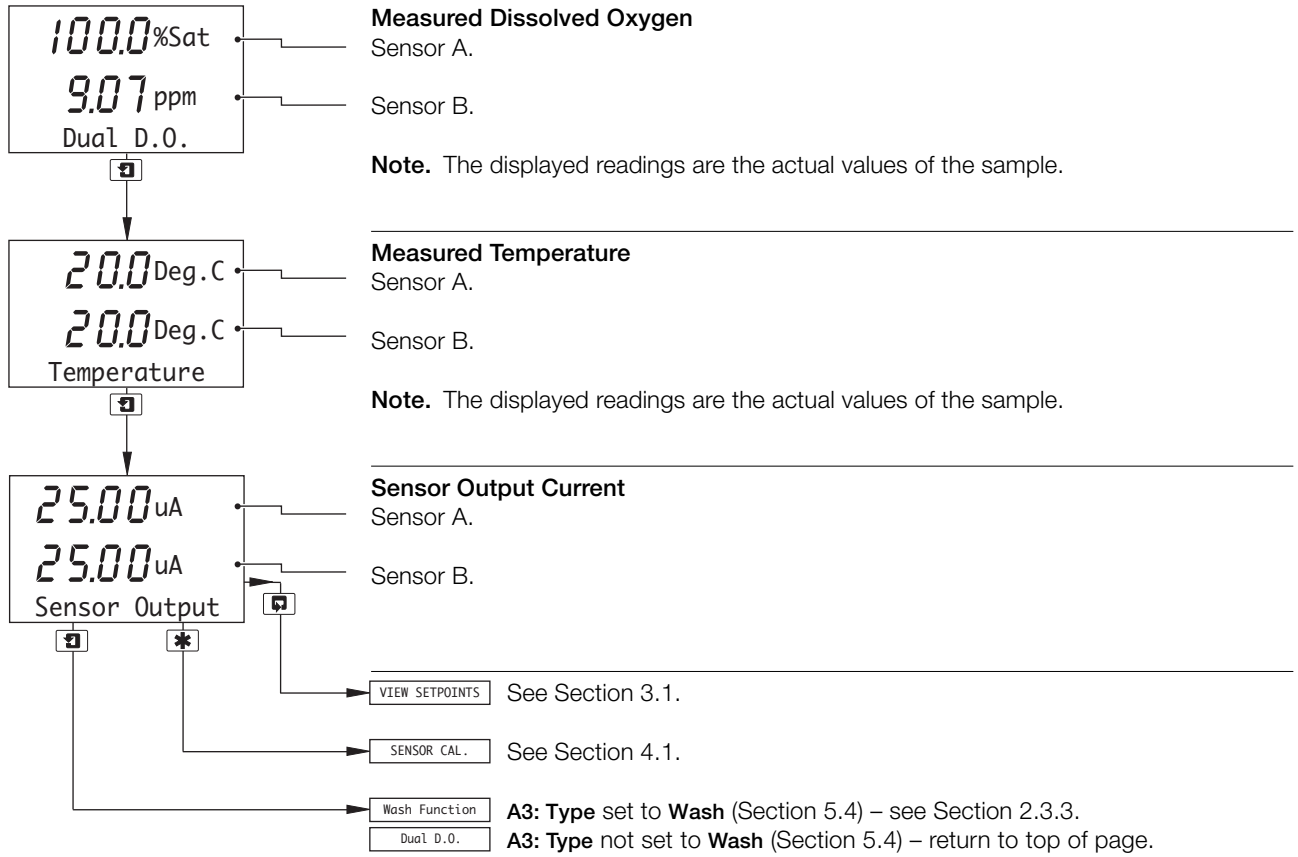

## ...2 OPERATION

### ...2.3 Operating Page

#### 2.3.3 Wash Function

**Note.** The Wash function is available only if **A3: Type** is set to **Wash** – see Section 5.4.

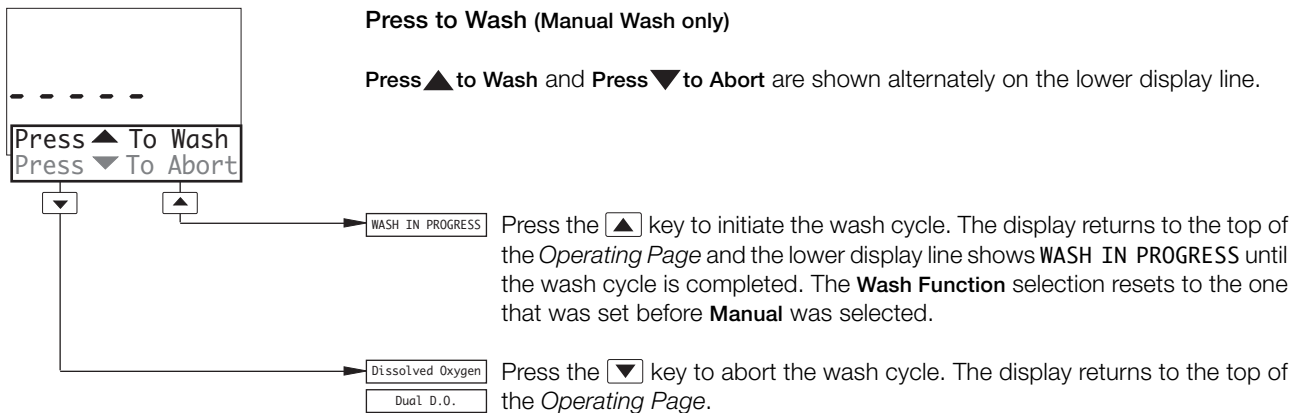
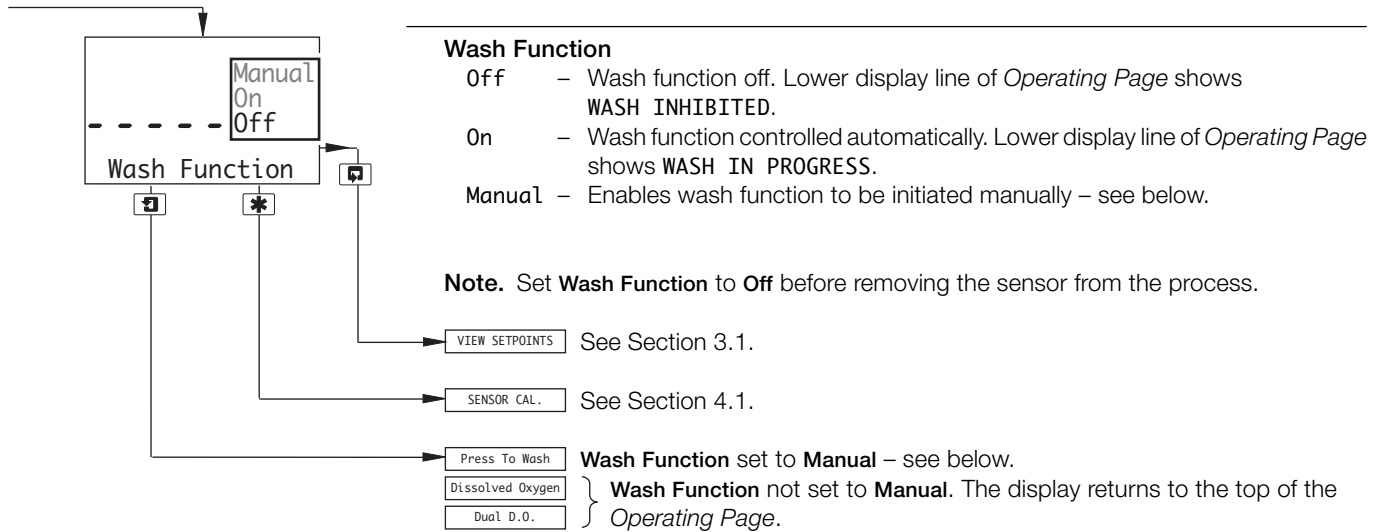

# 3 OPERATOR VIEWS

## 3.1 View Set Points

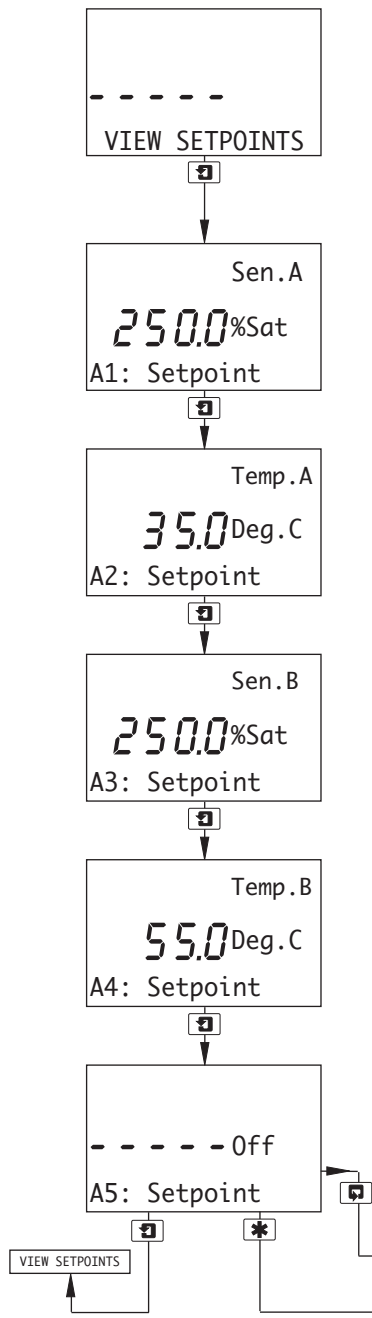

### View Set Points

This page shows alarm set points. The value of each of the set points is shown, together with the name of the parameter it's assigned to.

Alarm assignments, set point values and relay/LED actions are programmable – see Section 5.4. Those shown in the following frames are examples only.

### Sensor A (Dissolved Oxygen), Alarm 1 Set Point

### Sensor A (Temperature), Alarm 2 Set Point

### Sensor B (Dissolved Oxygen), Alarm 3 Set Point – Dual input analyzers only

### Sensor B (Temperature), Alarm 4 Set Point – Dual input analyzers only

**Note.** Alarm 4 available only if option board fitted **and** analog features enabled – see Section 7.3.

### Alarm 5 Set Point

**Note.** Alarm 5 available only if option board fitted **and** analog features enabled – see Section 7.3.

3.2 View Outputs

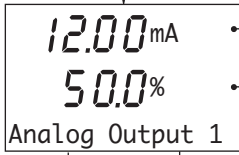
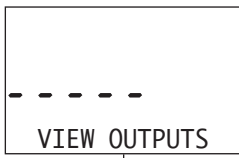

**Theoretical Analog Output**

There are up to four analog outputs, each showing information for one sensor.

**Note.** Analog outputs 3 and 4 available only if option board fitted **and** analog features enabled – see Section 7.3.

Live current output value being retransmitted.

Current output shown as a percentage of full scale for the output range set in **CONFIG. OUPUTS** – see Section 5.5.

VIEW HARDWARE See Section 3.3.

SENSOR CAL. See Section 4.1.

Analog Output 2 Advance to analog output 2 (and outputs 3 and 4 if option board fitted **and** analog features enabled – see Section 7.3).

3.3 View Hardware

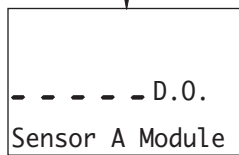
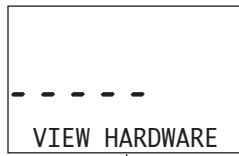

**Sensor A Module**

Shows the type of input board fitted to the analyzer for the Sensor A input.

D.O. – Dissolved Oxygen

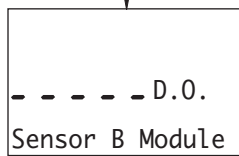

**Sensor B Module** – Dual input analyzers only

Shows the type of input board fitted to the analyzer for the Sensor B input.

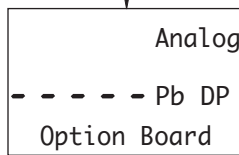

**Option Board**

**Note.** Displayed only if the option board is fitted.

Displays the optional features enabled in the **Factory Settings** page – see Section 7.3.

VIEW HARDWARE

VIEW SOFTWARE See Section 3.4.

SENSOR CAL. See Section 4.1.

### 3.4 View Software

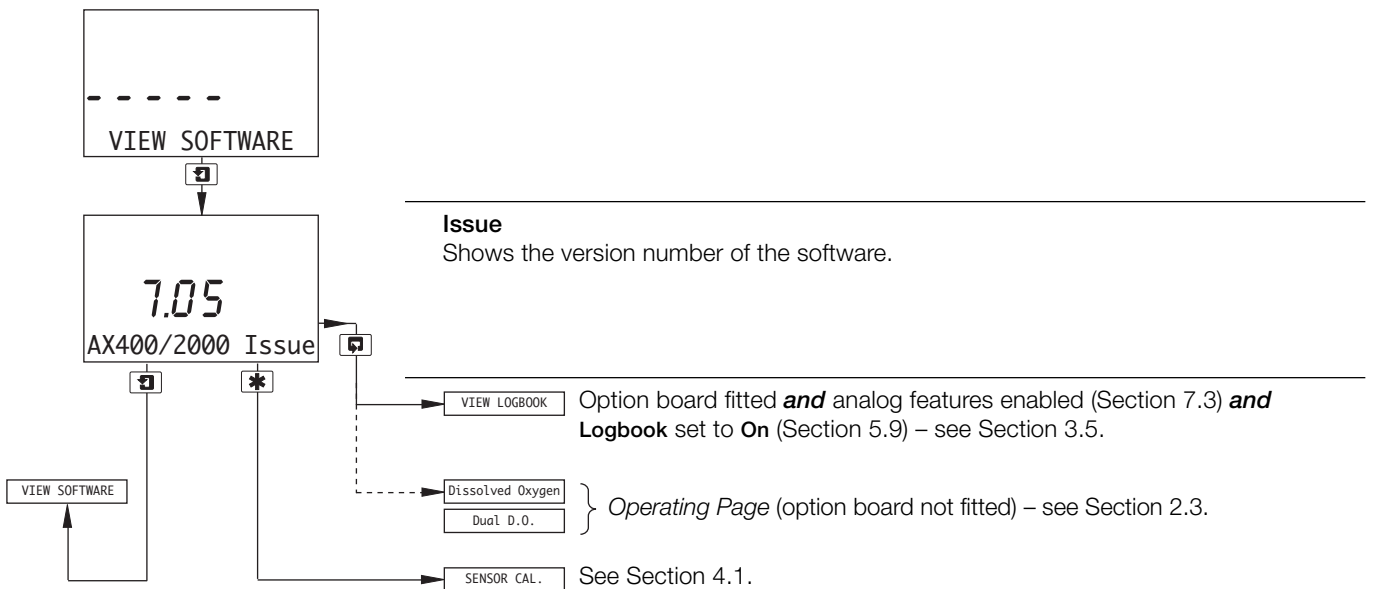

### 3.5 View Logbook

**Note.** The View Logbook function is available only if the option board is fitted **and** analog features enabled (Section 7.3) **and** Logbook is set to On (Section 5.9).

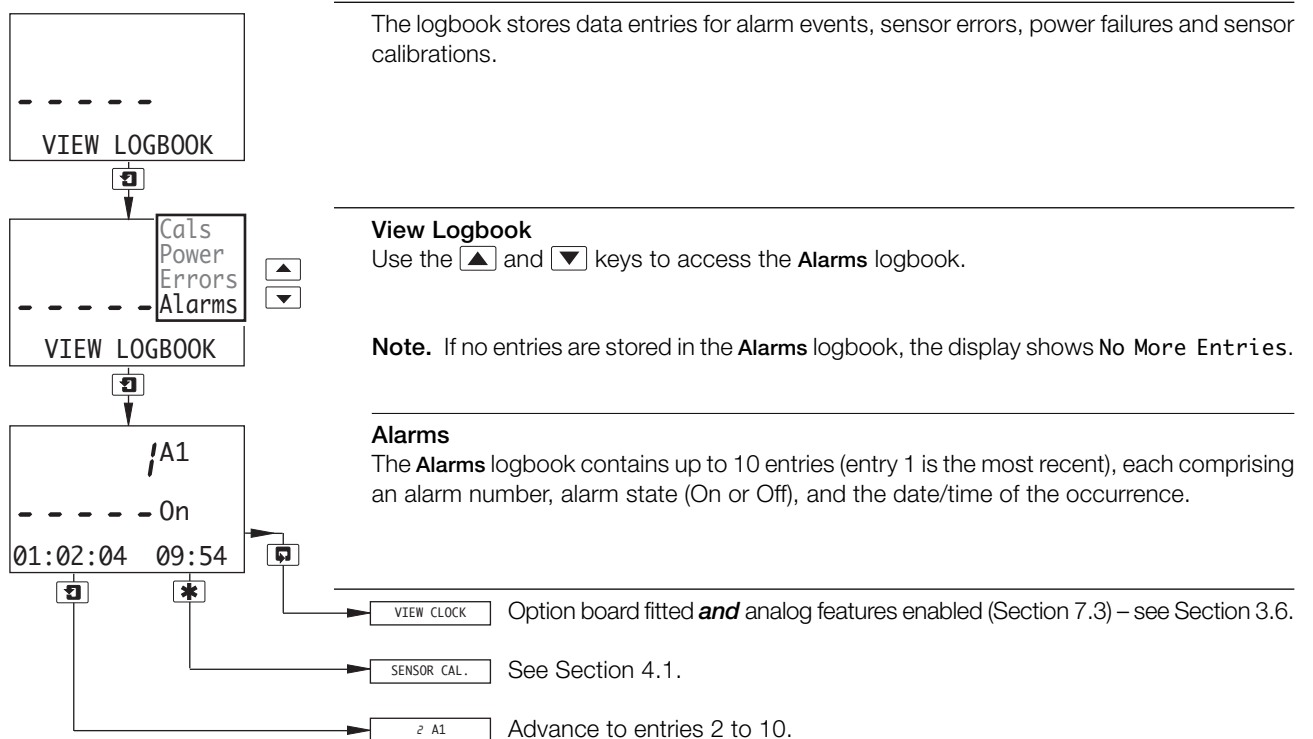

**Note.** If no more entries are stored, the display shows **No More Entries**.

### ...3 OPERATOR VIEWS

#### ...3.5 Logbook

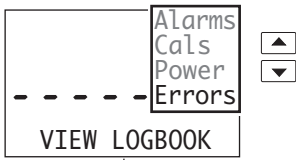

#### View Logbook

Use the and keys to access the **Errors** logbook.

**Note.** If no entries are stored in the **Errors** logbook, the display shows **No More Entries**.

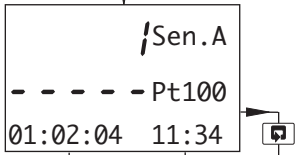

#### Errors

The **Errors** logbook contains up to 5 entries (entry 1 is the most recent), each comprising the sensor letter, error number and the date/time of the occurrence.

Option board fitted **and** analog features enabled (Section 7.3) – see Section 3.6.

See Section 4.1.

Advance to entries 2 to 5.

**Note.** If no more entries are stored, the display shows **No More Entries**.

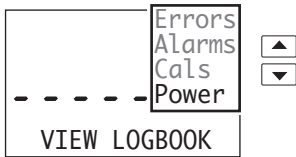

#### View Logbook

Use the and keys to access the **Power** logbook.

**Note.** If no entries are stored in the **Power** logbook, the display shows **No More Entries**.

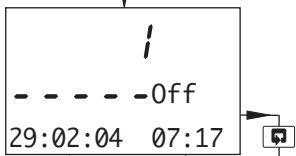

#### Power

The **Power** logbook contains up to 2 entries (entry 1 is the most recent), each comprising the power state (On or Off) and the date/time of the occurrence.

Option board fitted **and** analog features enabled (Section 7.3) – see Section 3.6.

See Section 4.1.

Advance to entry 2.

**Note.** If no more entries are stored, the display shows **No More Entries**.

...3.5 Logbook

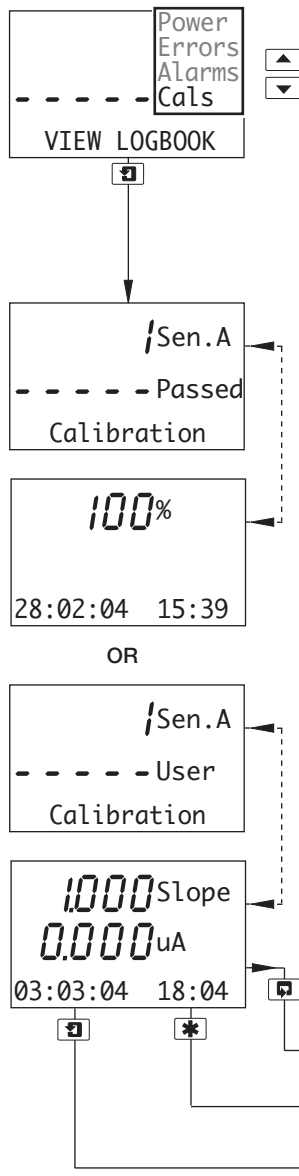

**View Logbook**

Use the ▲ and ▼ keys to access the **Cals** logbook.

**Note.** If no entries are stored in the **Cals** logbook, the display shows **No More Entries**.

**Calibration (Entry 1)**

The **Cals** logbook contains up to 5 entries (entry 1 is the most recent), each comprising 2 frames.

If an entry is generated by an automatic calibration:

- frame 1 contains the entry number, sensor letter and pass/fail indication.
- frame 2 contains the sensor % efficiency value, together with the date/time of the calibration.

If an entry is generated by a manual calibration:

- frame 1 contains the entry number, sensor letter and User indication.
- frame 2 contains the sensor zero and span (slope) values, together with the date/time of the calibration.

**Note.** If no more entries are stored, the display shows **No More Entries**.

**VIEW CLOCK** Option board fitted *and* analog features enabled (Section 7.3) – see Section 3.6.

**SENSOR CAL.** See Section 4.1.

**2 Sen.A** Advance to entries 2 to 5.

**Note.** If no more entries are stored, the display shows **No More Entries**.

### ...3 OPERATOR VIEWS

#### 3.6 View Clock

**Note.** The View Clock function is available only if the option board is fitted *and* analog features enabled – see Section 7.3.

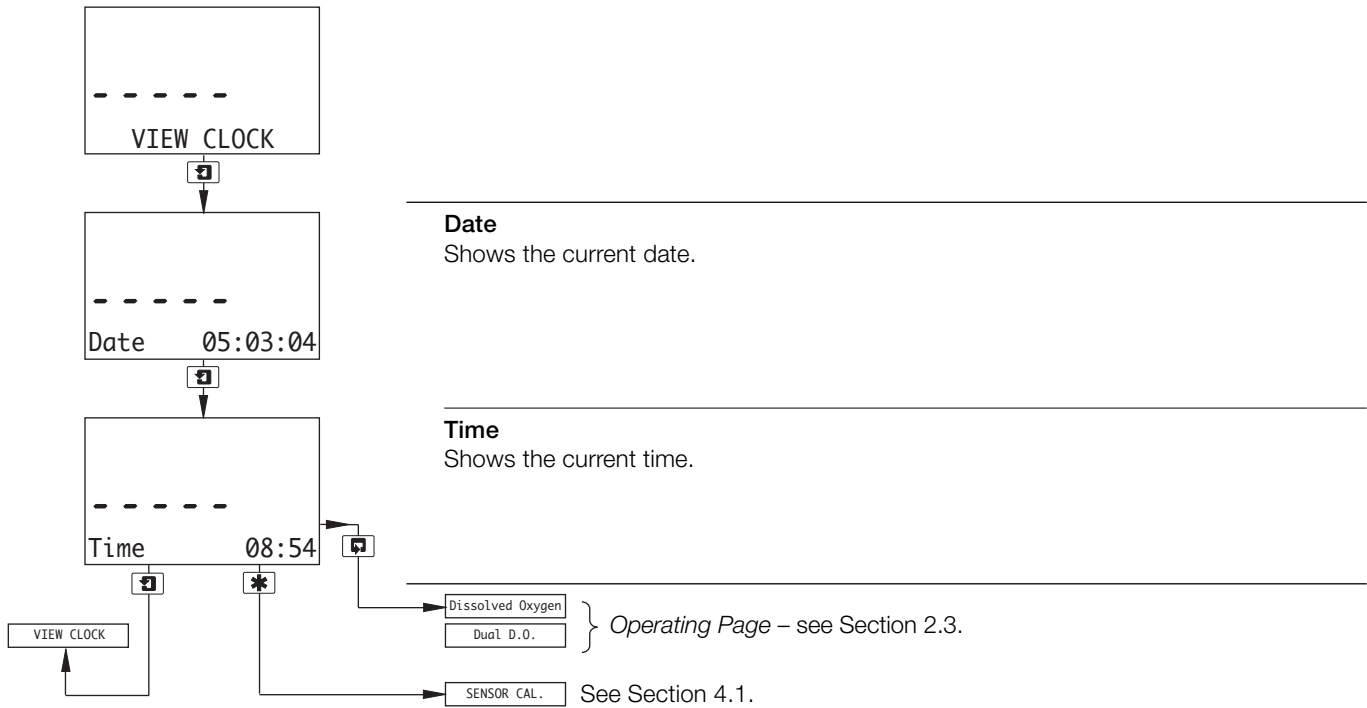

## 4 SETUP

### 4.1 Sensor Calibration

#### Notes.

- Sensor calibration involves standardizing the analyzer and the sensor using sample solutions and air.
- A 5% sodium sulphite, zero calibration solution is required for an automatic, commissioning calibration. Automatic, full scale (span) calibration is carried-out either in air or air-saturated water – see Appendix A3.

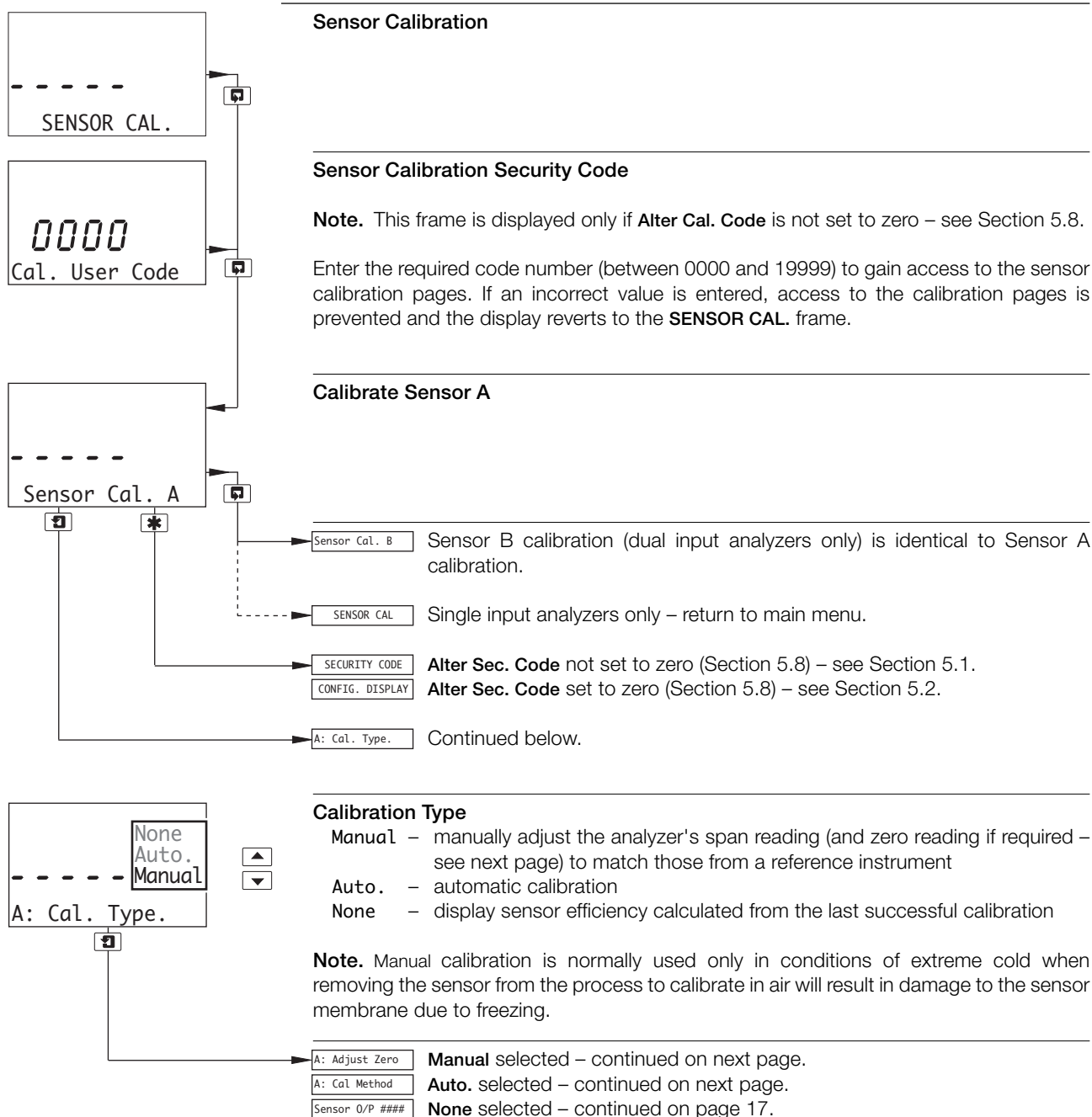

...4.1 Sensor Calibration

A: Cal. Type.  
set to Manual

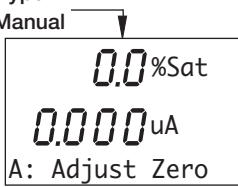

**Adjust Zero**

Adjust the  $\mu\text{A}$  value, between  $-2.000$  and  $2.000$  in  $0.001 \mu\text{A}$  increments, until the %Sat value matches that from the reference instrument.

Although the sensor can be immersed in a 5% sodium sulphite zero calibration solution (see Appendix A3.1) and zero adjusted manually, it is strongly recommended that, if this method is required, the automatic calibration type is used.

**Notes.**

- **Warning-Offset** is shown on the lower display line if the  $\mu\text{A}$  value is adjusted outside of the range  $-0.100$  to  $0.600$  – see Table 8.1, page 55.
- **Out-of-Range** is shown on the lower display line if the  $\mu\text{A}$  value is adjusted to the maximum of its range ( $\pm 2.000$ ). Adjustment outside this range is not possible – see Table 8.1, page 55.

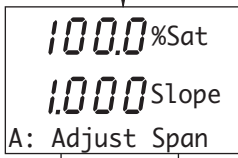

**Adjust Span**

Adjust the **Slope** value, between  $0.400$  and  $2.500$  in  $0.001$  increments, until the %Sat value matches that from the reference instrument.

**Notes.**

- **Warning-Low O/P** is shown on the lower display line if the **Slope** value is adjusted above  $2.000$  – see Table 8.1, page 54.
- **Out-of-Range** is shown on the lower display line if the **Slope** value is adjusted to the maximum of its range ( $0.400$  to  $2.500$ ). Adjustment outside this range is not possible – see Table 8.1, page 55.

Sensor Cal. B Sensor B calibration (dual input analyzers only) is identical to Sensor A calibration.

SENSOR CAL Single input analyzers only – return to main menu.

SECURITY CODE Alter Sec. Code not set to zero (Section 5.8) – see Section 5.1.  
CONFIG. DISPLAY Alter Sec. Code set to zero (Section 5.8) – see Section 5.2.

Sensor O/P ##### Continued on next page.

A: Cal. Type.  
set to Auto.

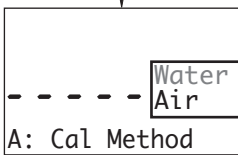

**Calibration Method**

Select the medium to be used for span calibration.

- Air** – Dry the sensor thoroughly and expose to air
- Water** – Immerse the sensor in air-saturated water

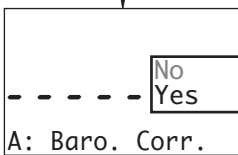

**Automatic Barometric Correction**

If the local barometric pressure is known, select **Yes** to enable automatic barometric correction.

If the local barometric pressure is not known, select **No**. The analyzer functions using the standard sea-level value barometric pressure ( $760\text{mm Hg}$ ) unless automatic altitude correction is selected below.

A: Pressure Yes selected – continued on next page.  
A: Alt. Corr. No selected – continued on next page.

...4.1 Sensor Calibration

A: Cal. Type.  
set to None

-----  
Sensor O/P #####

**Sensor Output**

The sensor efficiency calculated from the last successful calibration is displayed. When five bars are displayed, the sensor has maximum life remaining. When one bar is displayed and flashing, the sensor is exhausted. Order a replacement sensor when two bars are displayed.

A: Cal. Type. Return to page 15.

A: Baro. Corr.  
set to Yes

760 mmHg  
A: Pressure

**Barometric Pressure**

Set the local barometric pressure in mm Hg.

A: Cal. Type. Continued below.

A: Baro. Corr.  
set to No

----- No  
----- Yes  
A: Alt. Corr.

**Automatic Altitude Correction**

If the local barometric pressure is not known but the analyzer is installed at a known altitude significantly above sea-level (e.g. above 50m [164 ft.]), select **Yes** to enable automatic altitude correction.

If the local altitude is not known, select **No**. If neither automatic barometric correction nor automatic altitude correction have been selected, the analyzer functions at a default setting of 0m (sea-level) and 760mm Hg.

No  
Yes

50 m  
A: Altitude

**Altitude**

Set the local altitude in metres above sea level (1m = 3.28 ft.).

----- Std  
----- Comm  
A: Cal. Type.

**Calibration Type**

Select the required calibration type:

- Comm - (Commissioning calibration) includes a zero calibration procedure using 5% sodium sulphite. Recommended method following system installation or capsule change.
- Std - (Standard calibration) bypasses the zero calibration procedure. Recommended method for routine calibration.

Immerse Zero Sol Comm selected – continued on next page.

Immerse Span Sol A: Cal Method set to **Water and Std** selected – continued on next page.

Expose to Air A: Cal Method set to **Air and Std** selected – continued on next page.

...4.1 Sensor Calibration

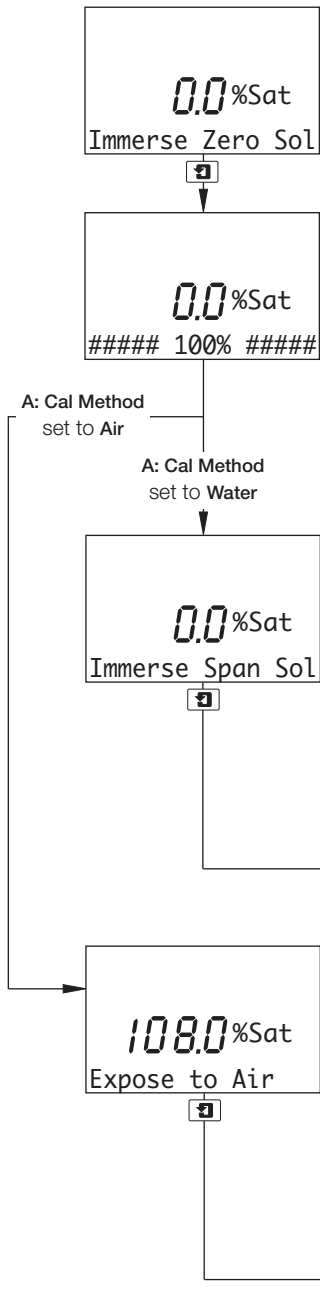

**Zero Calibration**

Immerse the sensor in a 5% sodium sulphite solution.

Press the **F1** key to initiate calibration.

**Note.** To abort calibration, press the **F1** key again at any time before calibration is complete – see next page.

The center display line shows, in the units selected in the **CONFIG. SENSORS** page (Section 5.3), the value to which the instrument's reading will be set following a successful zero calibration.

As calibration proceeds, a progress indicator appears in the lower display line. When a stable reading is detected, the lower display line shows **##### 100% #####** for 2 seconds, the display then advances automatically to the next frame.

**Span Calibration (Water Calibration Method)**

Thoroughly rinse the sensor with demineralized water and carefully dry the sensor capsule with a soft tissue.

Immerse the sensor capsule in air-saturated water.

Press the **F1** key to initiate calibration.

**Note.** To abort calibration, press the **F1** key again at any time before calibration is complete – see next page.

**Span Calibration (Air Calibration Method)**

Thoroughly rinse the sensor with demineralized water and carefully dry the sensor capsule with a soft tissue.

Expose the sensor to air.

Press the **F1** key to initiate calibration.

**Note.** To abort calibration, press the **F1** key again at any time before calibration is complete – see next page.

## ...4.1 Sensor Calibration

0.0%Sat  
##### 100% #####

-----  
Sensor O/P #####



The center display line shows, in the units selected in the **CONFIG. SENSORS** page (Section 5.3), the value to which the instrument's reading will be set following a successful span calibration. If either automatic barometric or altitude correction were selected, the displayed value includes the correction.

As calibration proceeds, a progress indicator appears in the lower display line. When a stable reading is detected, the lower display line shows **##### 100% #####** for 2 seconds, the display then advances automatically to the next frame.

**Sensor Output**

Provides an indication of sensor performance. When five bars are displayed, the sensor has maximum life remaining. When one bar is displayed and flashing, the sensor is exhausted. Order a replacement sensor when two bars are displayed.

**Note.** If a calibration results in a sensor efficiency indication of one bar, that calibration is ignored and the values obtained from the previous calibration are used.

Sensor Cal. A Return to top of page.

-----Yes  
A: Abort Cal.

**Abort Calibration**

Select **Yes** or **No**.

Sensor Cal. A **Yes** selected – return to top of page.

### 26% **No** selected – calibration continues.

---

## 5 PROGRAMMING

---

### 5.1 Security Code



---

**Note.** This frame is displayed only if **Alter Sec. Code** is not set to zero – see Section 5.8.

Enter the required code number (between 0000 and 19999), to gain access to the configuration pages. If an incorrect value is entered, access to the configuration pages is prevented and the display reverts to the *Operating Page* – see Section 2.3.

---

→ CONFIG. DISPLAY See Section 5.2.

5.2 Configure Display

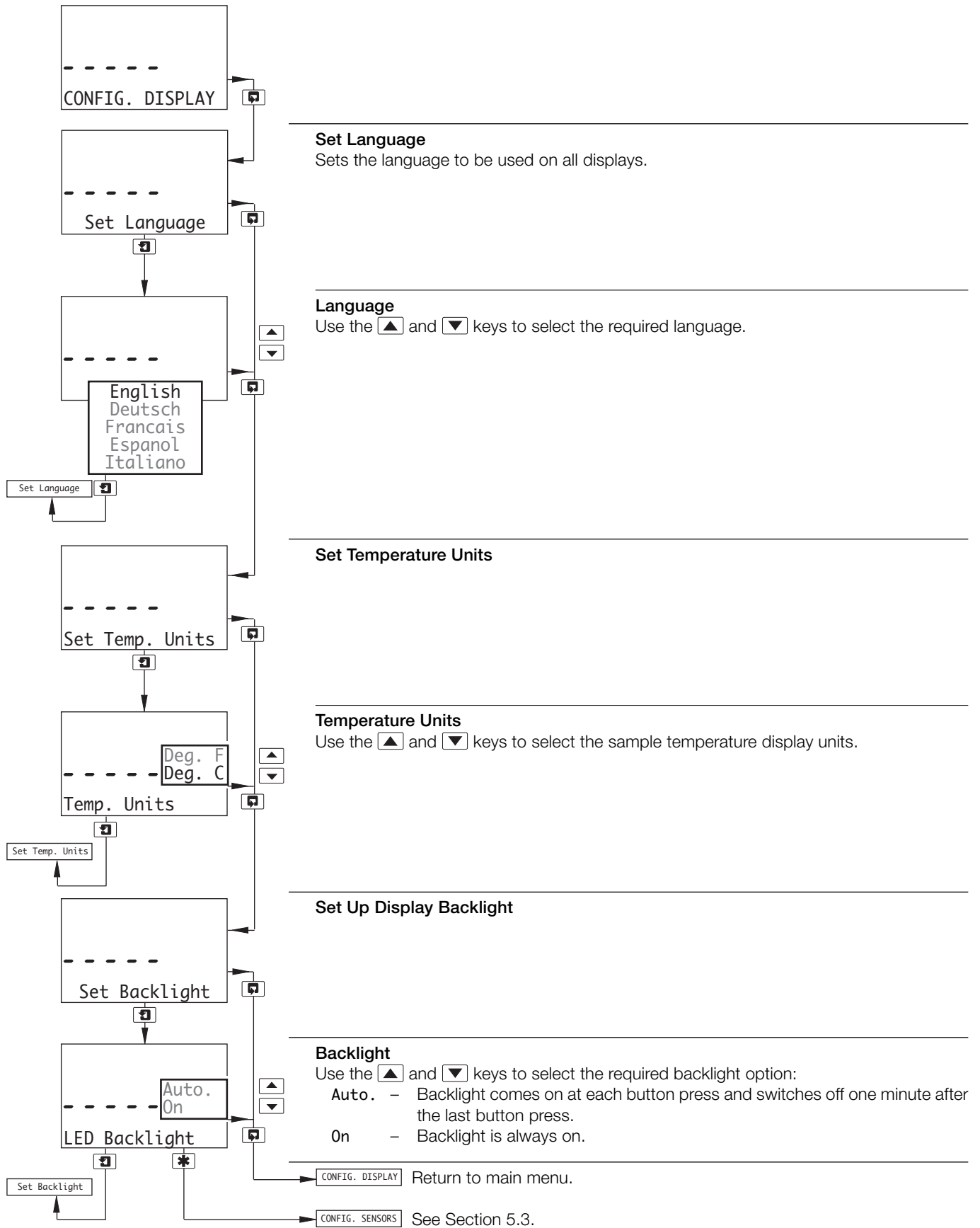

5.3 Configure Sensors

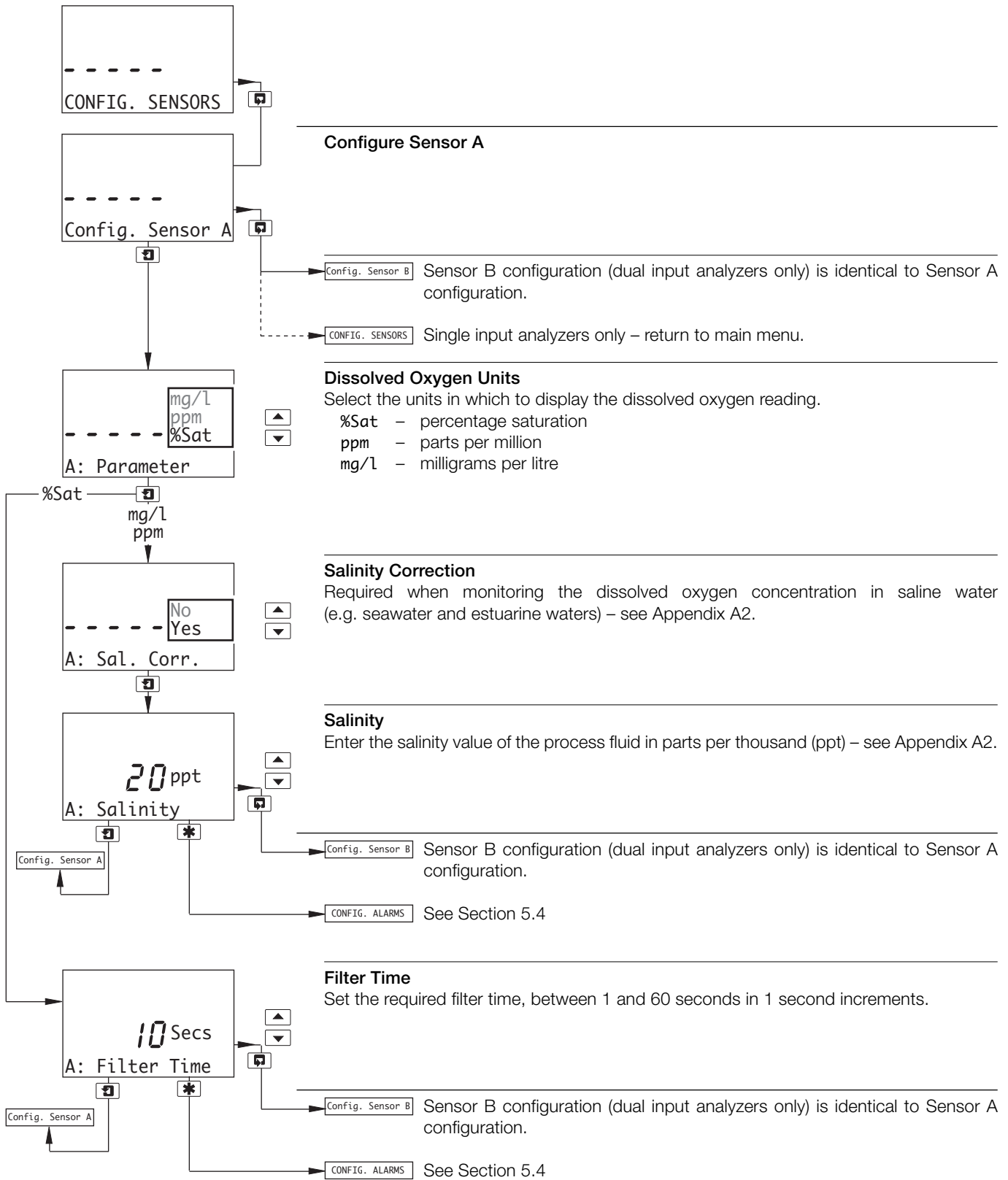

5.4 Configure Alarms

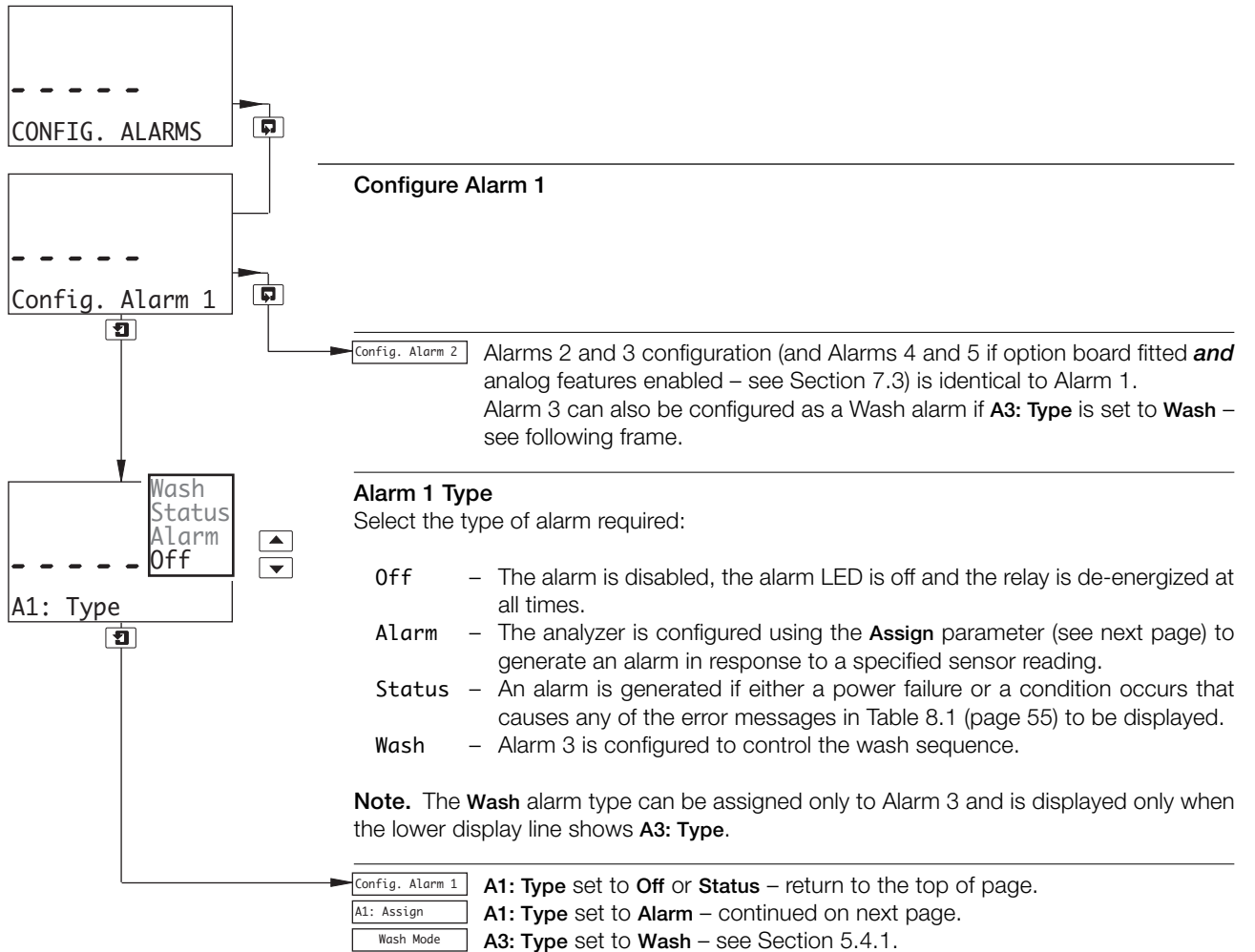

...5.4 Configure Alarms

A1: Type

set to Alarm

A1: Assign

**Alarm 1 Assign**

Select the alarm assignment required:

- Sen.A – The analyzer activates an alarm if the dissolved oxygen content of the process fluid measured by the selected sensor exceeds or drops below the value set in the **Alarm 1 Set Point** parameter, depending on the type of **Alarm 1 Action** selected – see next page.
- Sen.B – The analyzer activates an alarm if the dissolved oxygen content of the process fluid measured by the selected sensor exceeds or drops below the value set in the **Alarm 1 Set Point** parameter, depending on the type of **Alarm 1 Action** selected – see next page.
- Temp.A – The analyzer activates an alarm if the temperature of the process fluid measured by the selected sensor exceeds or drops below the value set in the **Alarm 1 Set Point** parameter, depending on the type of **Alarm 1 Action** selected – see next page.
- Temp.B – The analyzer activates an alarm if the temperature of the process fluid measured by the selected sensor exceeds or drops below the value set in the **Alarm 1 Set Point** parameter, depending on the type of **Alarm 1 Action** selected – see next page.
- A-B – The analyzer activates an alarm if the difference between the Sensor A and Sensor B readings exceeds or drops below the value set in the **Alarm 1 Set Point** parameter, depending on the type of **Alarm 1 Action** selected – see next page.

**Note.** The **Sen.B**, **Temp.B** and **A-B** alarm assignment types are applicable only to dual input analyzers and **A-B** is displayed only when the **Parameter** selection for each sensor is identical – see Section 5.3.

A1: Failsafe Continued on next page.

...5.4 Configure Alarms

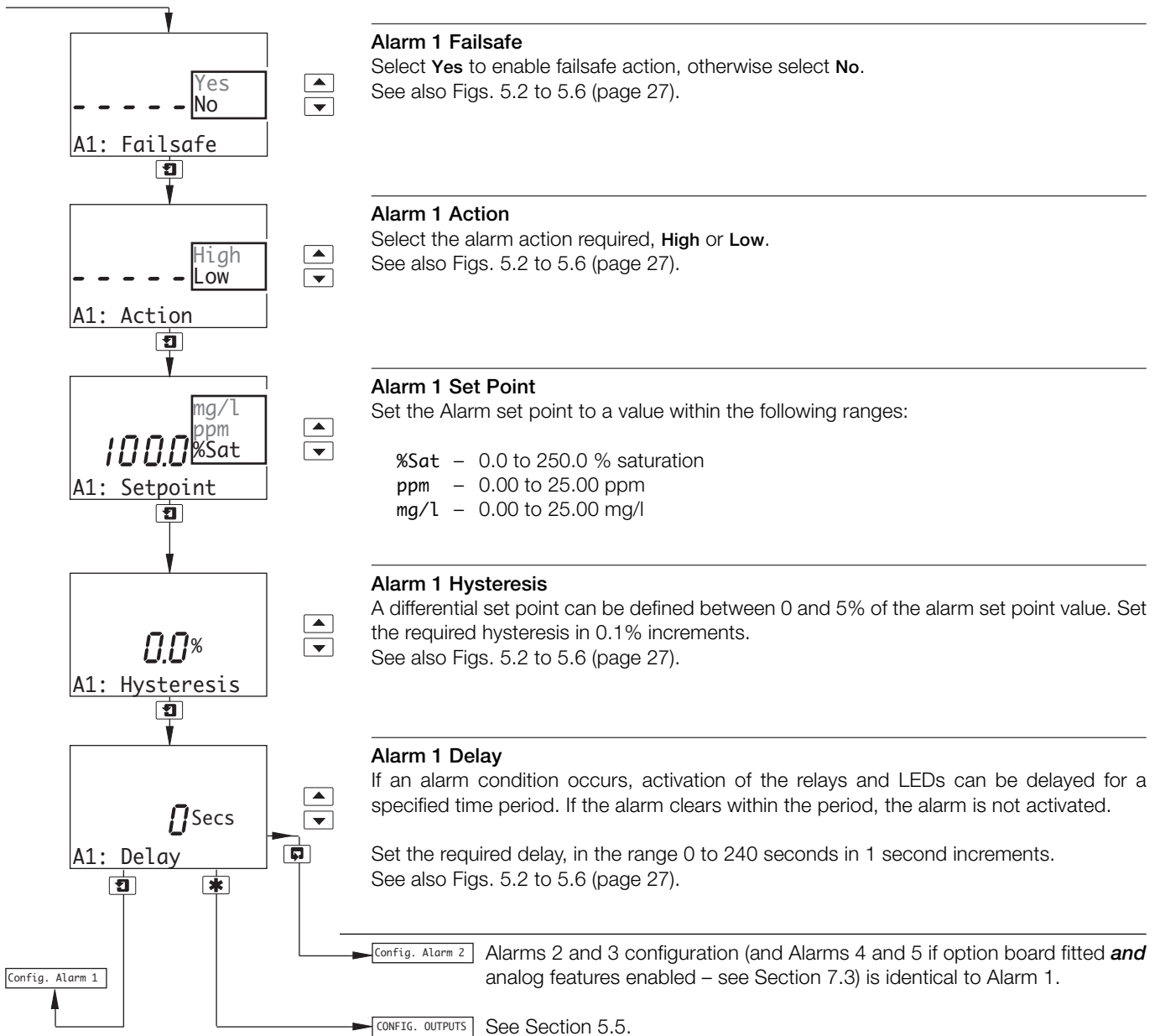

...5.4 Configure Alarms

5.4.1 Wash Cycle Configuration (applicable only to Alarm 3)

A3: Type  
set to Wash

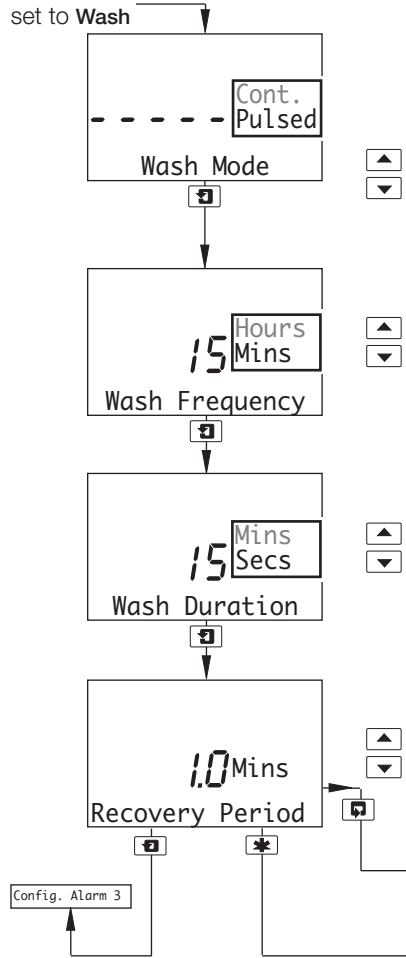

**Wash Mode**

Select the wash mode required.

- Cont. – (continuous) the relay remains energized for the wash duration
- Pulsed – the relay is switched on and off every second for the duration of the wash, – see Fig. 5.1

**Wash Frequency**

Set the wash frequency required.

Wash frequency is set in 15 minute increments between 15 and 45 minutes, then in 1 hour increments between 1 and 24 hours.

**Wash Duration**

Set the wash duration required.

Wash duration is set in 15 second increments between 15 and 45 seconds, then in 1 minute increments between 1 and 10 minutes.

**Recovery Period**

Set the recovery period required, between 0.5 and 5.0 minutes in 0.5 minute increments.

Config. Alarm 4 Option board fitted **and** analog features enabled (Section 7.3) – Alarm 4 configuration is identical to Alarm 1.

CONFIG. OUTPUTS Option board not fitted **or** option board fitted **and** analog features disabled (Section 7.3) – see Section 5.5.

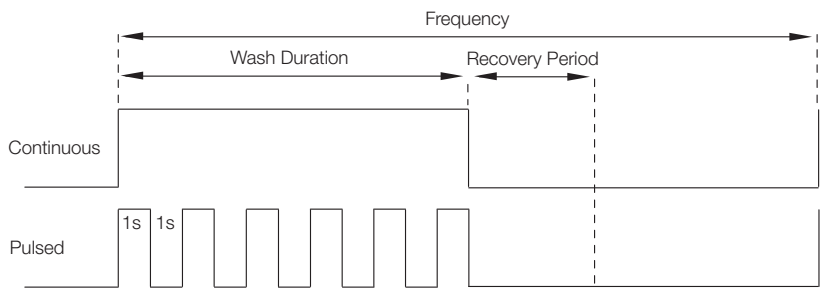
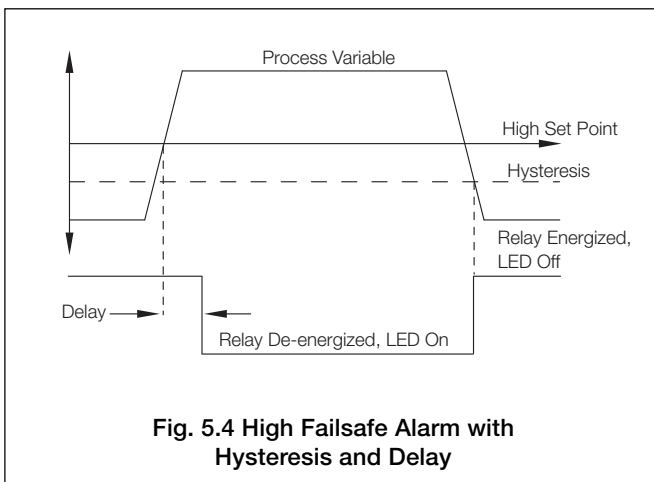
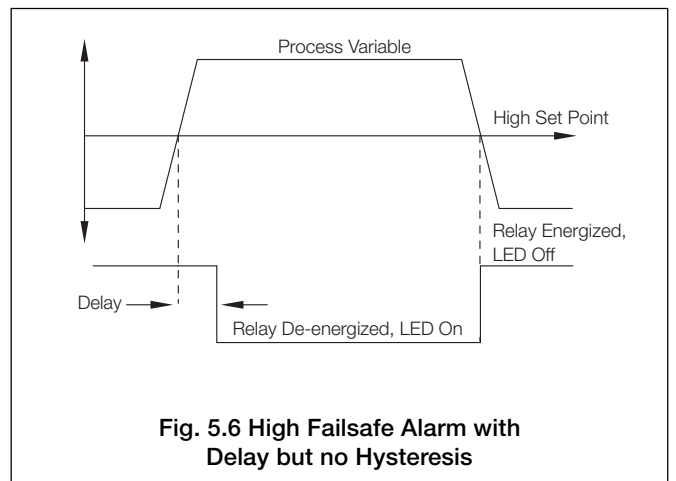
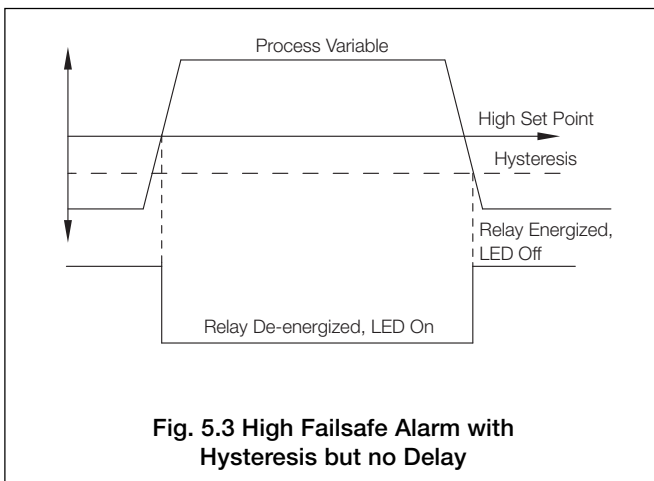
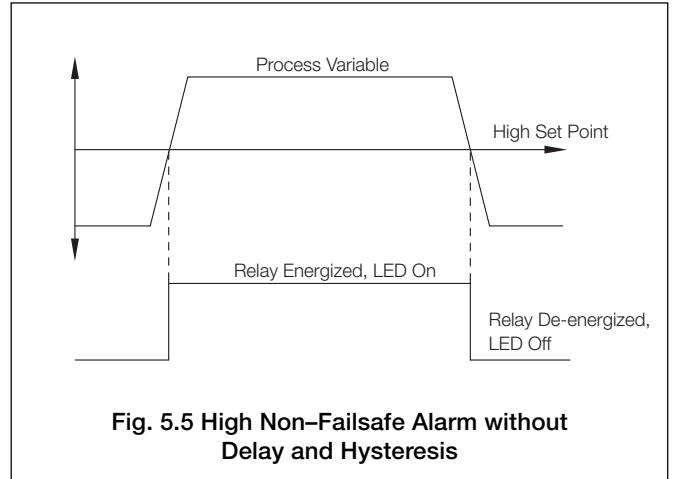
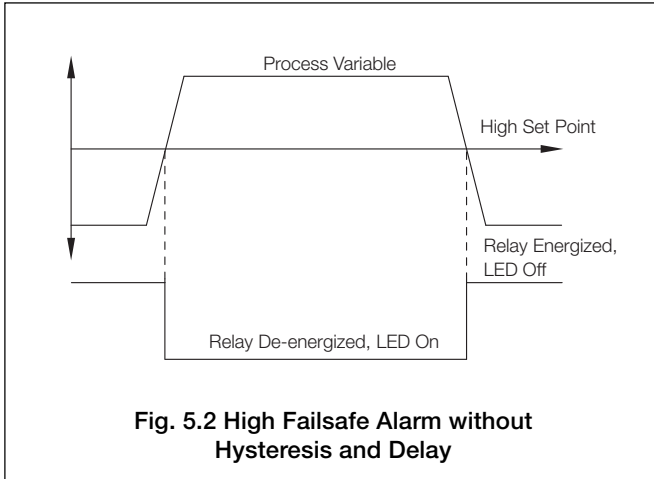

Fig. 5.1 Pulsed and Continuous Wash Cycles

...5.4 Configure Alarms

**Note.** The following examples illustrate **High Alarm Actions**, i.e. the alarm is activated when the process variable exceeds the defined set point. **Low Alarm Actions** are the same, except the alarm is activated when the process variable drops below the defined set point.



5.5 Configure Outputs

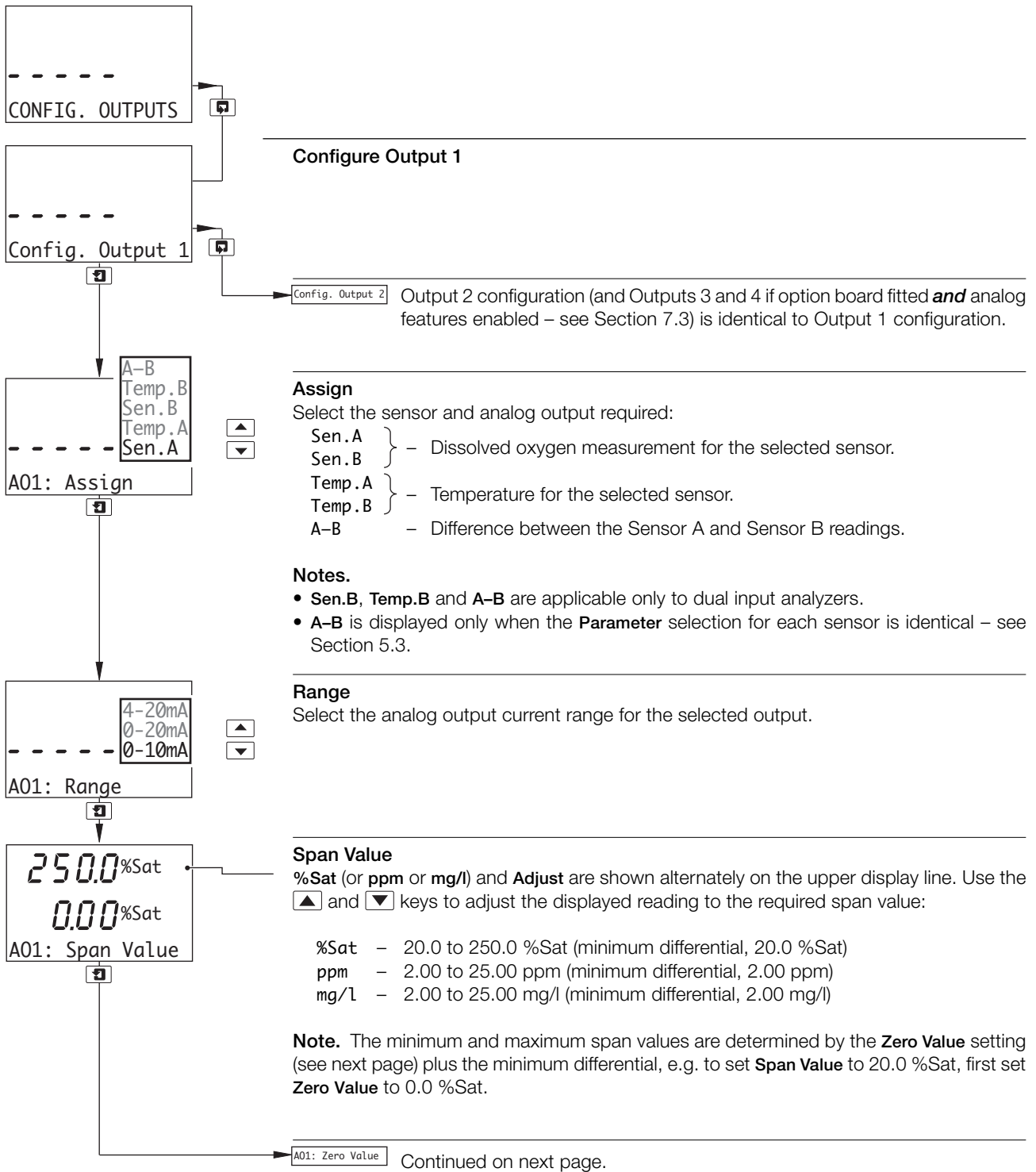

...5.5 Configure Outputs

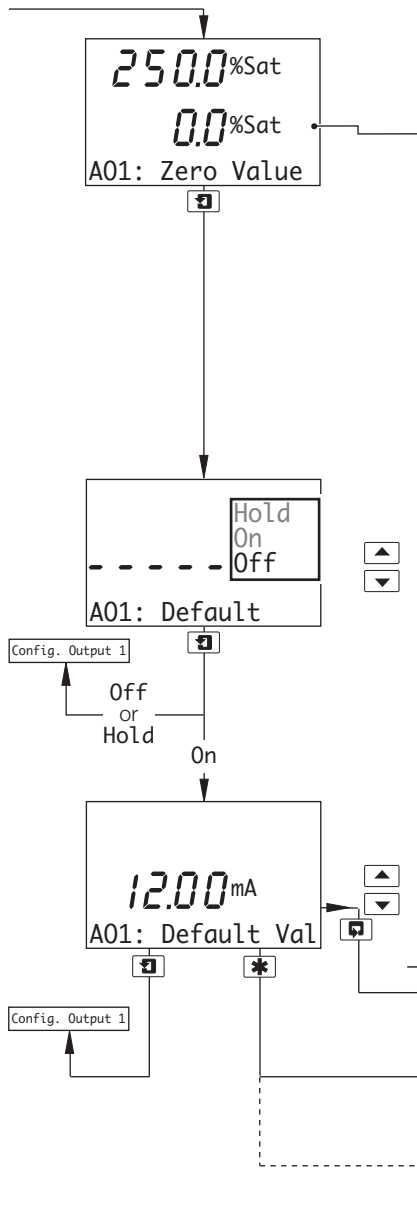

**Zero Value**

%Sat (or ppm or mg/l) and Adjust are shown alternately on the center display line. Use the ▲ and ▼ keys to adjust the displayed reading to the required zero value:

- %Sat – 0.0 to 230.0 %Sat (minimum differential, 20.00 %Sat)
- ppm – 0.00 to 23.00 ppm (minimum differential, 2.00 ppm)
- mg/l – 0.00 to 23.00 mg/l (minimum differential, 2.00 mg/l)

**Note.** The zero value setting plus the minimum differential determines the minimum and maximum values for the span setting, e.g. to set **Span Value** to 2.0 ppm, first set **Zero Value** to 0.00 ppm.

**Default Output**

Select the system reaction to failure:

- Hold – Hold the analog output at the value prior to the failure.
- On – Stop on failure. This drives the analog output to the level set in the **Default Val** frame below.
- Off – Ignore failure and continue operation.

**Default Value**

The level to which the analog output is driven if a failure occurs.

Set the value between 0.00 and 22.00mA.

- Config. Output 2 Output 2 configuration (and Outputs 3 and 4 if option board fitted **and** analog features enabled – see Section 7.3) is identical to Output 1 configuration.
- CONFIG. CLOCK Option board fitted **and** analog features enabled (Section 7.3) – see Section 5.6.
- CONFIG. SERIAL Option board fitted **and** Serial Communications feature enabled (Section 7.3) – see Supplementary Manual *PROFIBUS Datalink Description (IM/PROBUS)*.
- CONFIG. CONTROL Single input analyzer **and** option board not fitted – see Section 5.7.
- CONFIG. SECURITY Dual input analyzer **and** option board not fitted – see Section 5.8.

5.6 Configure Clock

**Note.** The Configure Clock function is available only if the option board is fitted **and** analog features enabled – see Section 7.3.

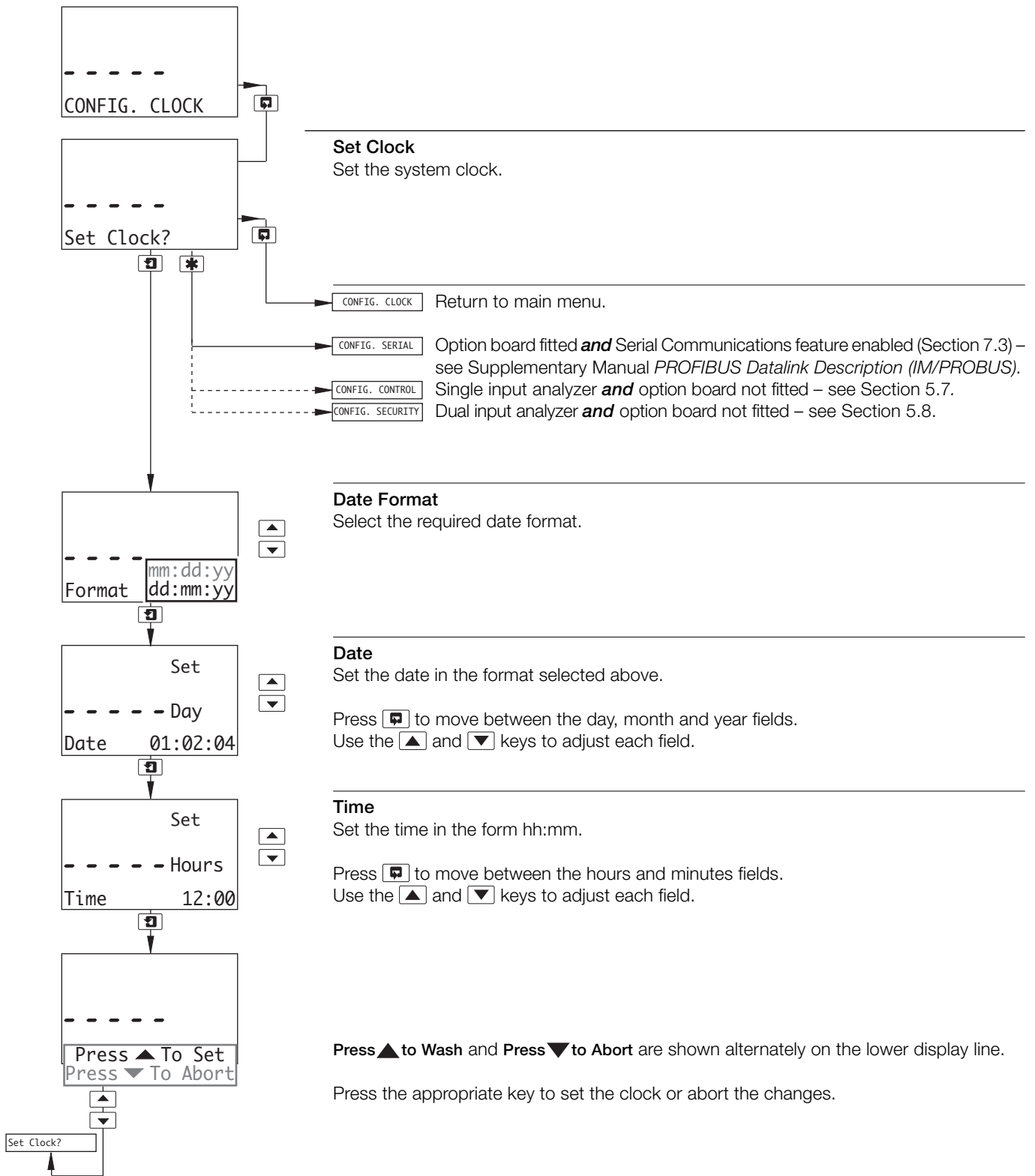

## 5.7 Configure Control

### Notes.

- PID control is applicable only to single input analyzers.
- Before configuring the PID controller, refer to Appendix B for further information.

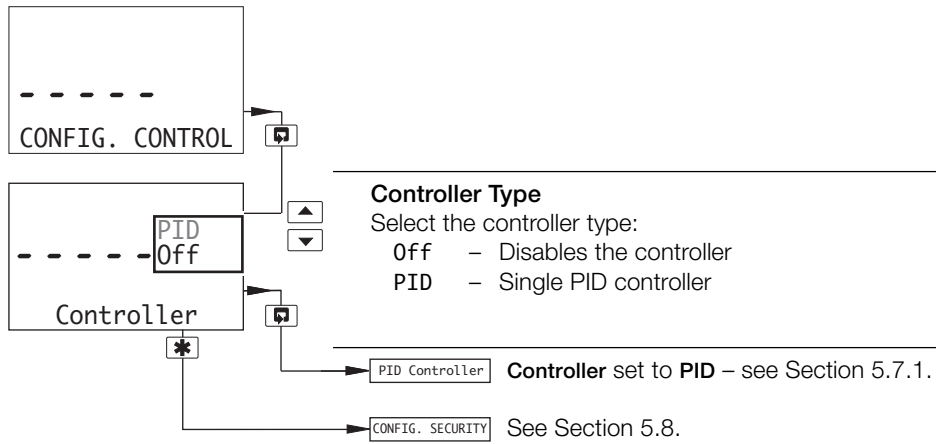

...5.7 Configure Control

5.7.1 Configure Single PID Controller

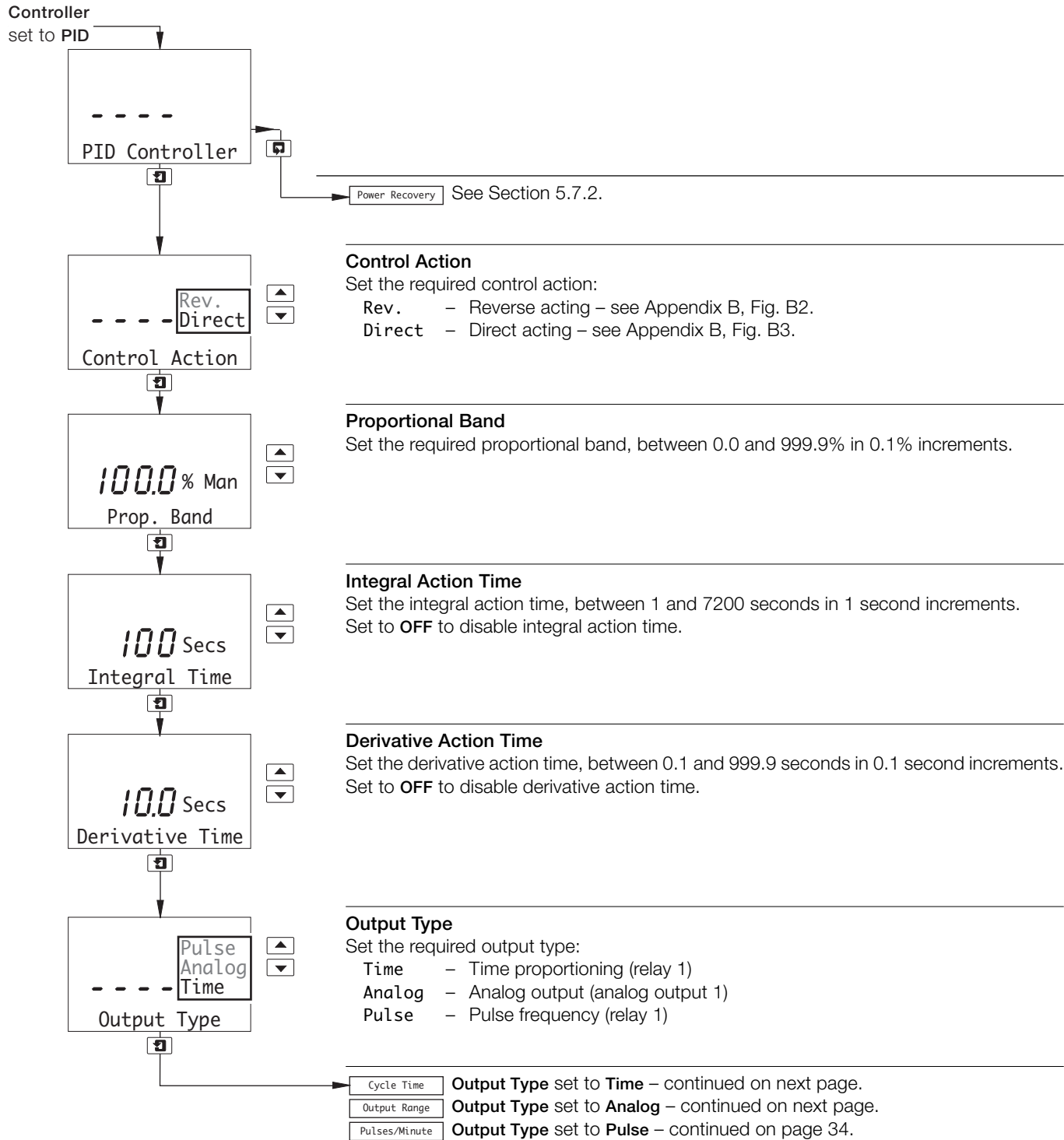

...5.7 Configure Control

...5.7.1 Configure Single PID Controller

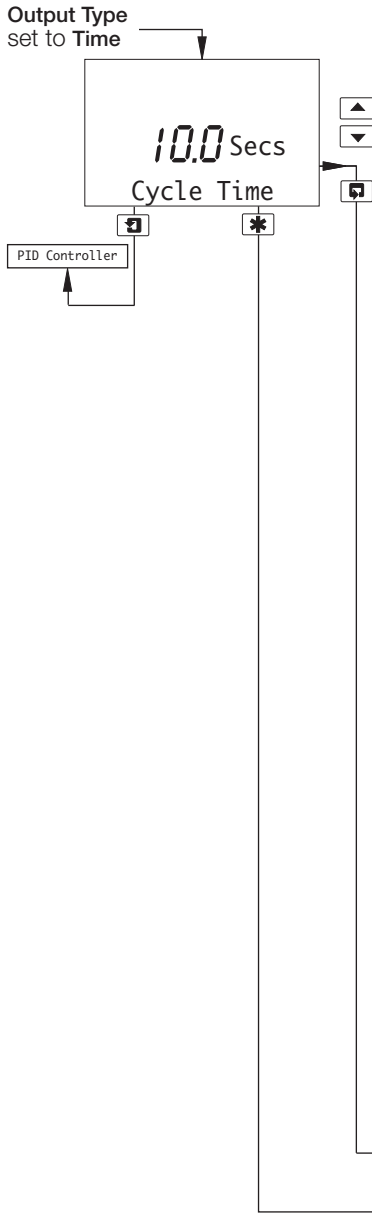

**Time Proportioning Output**

The Time Proportioning Output is interrelated to the retention time of the vessel and the flow of the chemical reagent and is adjusted experimentally to ensure that the chemical reagent is adequate to control the dosing under maximum loading. It is recommended that the Time Proportioning Output is adjusted in Manual Mode set to 100% valve output before setting up the PID parameters.

The time proportioning output value is calculated using the following equation:

$$\text{on time} = \frac{\text{control output} \times \text{cycle time}}{100}$$

Set the cycle time, between 1.0 and 300.0 seconds in 0.1 second increments – see Appendix B, Fig. B4 Mode C.

**Note.** Changes to the cycle time do not take effect until the start of a new cycle.

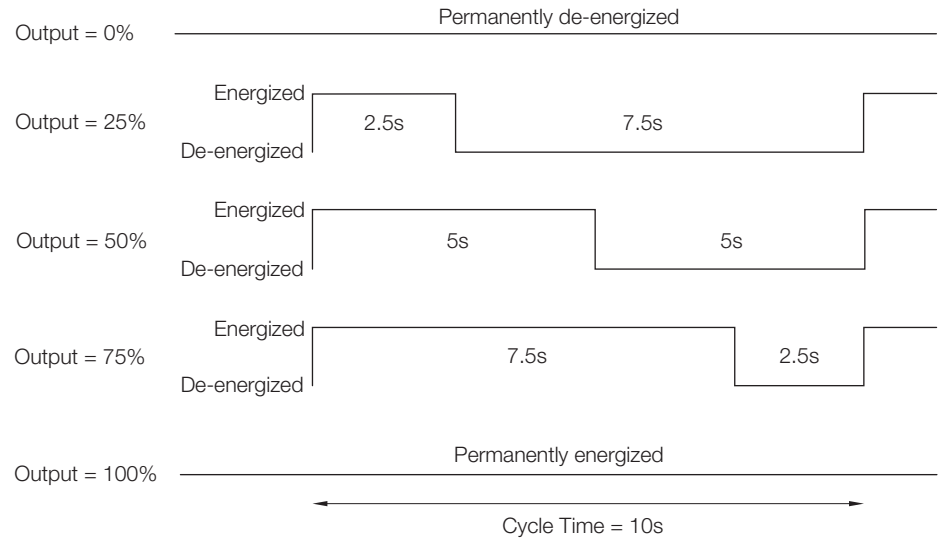

Power Recovery See Section 5.7.2.

CONFIG. SECURITY See Section 5.8.

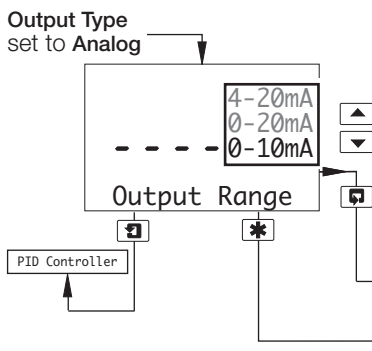

**Analog Output**

Set the analog current output range.

Power Recovery See Section 5.7.2.

CONFIG. SECURITY See Section 5.8.

...5.7 Configure Control

...5.7.1 Configure Single PID Controller

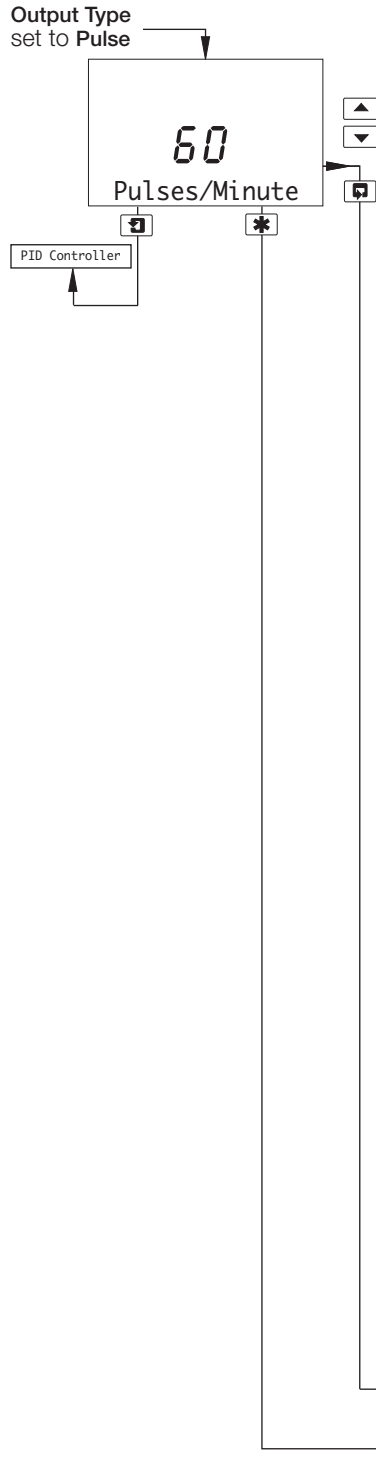

**Pulse Frequency Output**

The pulse frequency output is the number of relay pulses per minute required for 100% control output. The Pulse Frequency Output is interrelated to the chemical reagent strength and the solution flow rate. The chemical reagent flowrate and pulse frequency is adjusted experimentally to ensure that the chemical reagent is adequate to control the dosing under maximum loading. Adjust the Pulse Frequency Output in Manual Mode and set to 100% valve output before setting up the PID parameters.

For example, if the observed value on the display is 6 and the control point is 5 then the frequency needs to be increased.

The actual number of pulses per minute is calculated using the following equation:

$$\text{Actual pulses per minute} = \frac{\% \text{ control output} \times \text{pulse frequency output}}{100}$$

Set the pulse frequency between 1 and 120 pulses per minute in 1 pulse per minute increments.

Control Output	Pulse Frequency Output/Minute			
	1	10	50	120
0	0	0	0	0
25	0.25	2.5	12.5	30
50	0.50	5.0	25	60
75	0.75	7.5	37.5	90
100	1.00	10.0	50	120

**Note.** If the pulse frequency of 120 is reached then concentration of the reagent needs to be increased.

**Note.** Changes to the pulse frequency do not take effect until the start of a new cycle.

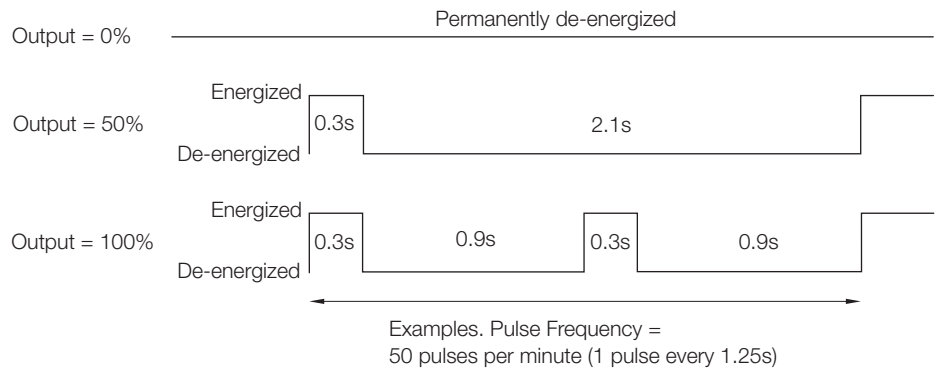

## ...5.7 Configure Control

## 5.7.2 Configure Power Failure Recovery Mode

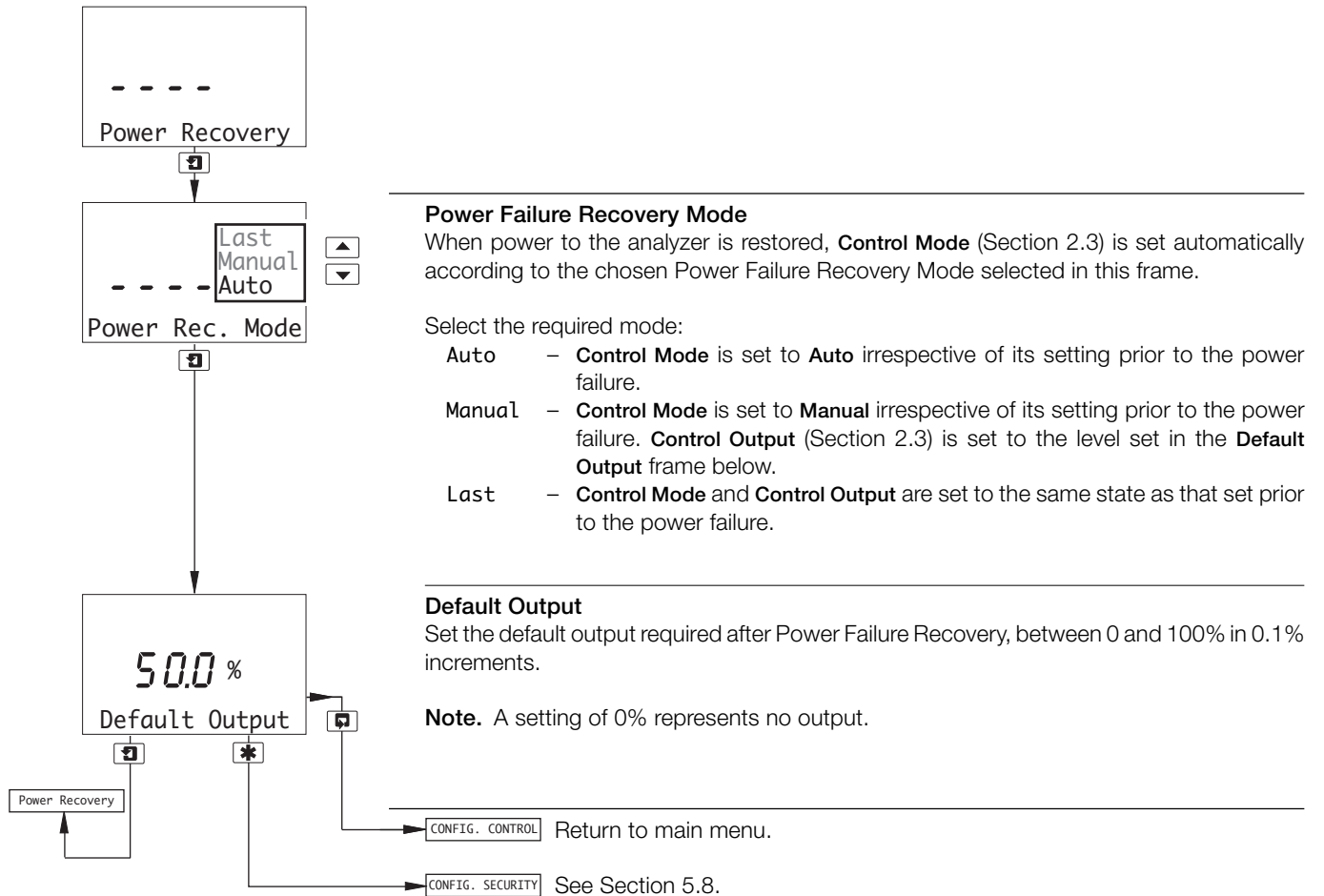

### 5.8 Configure Security

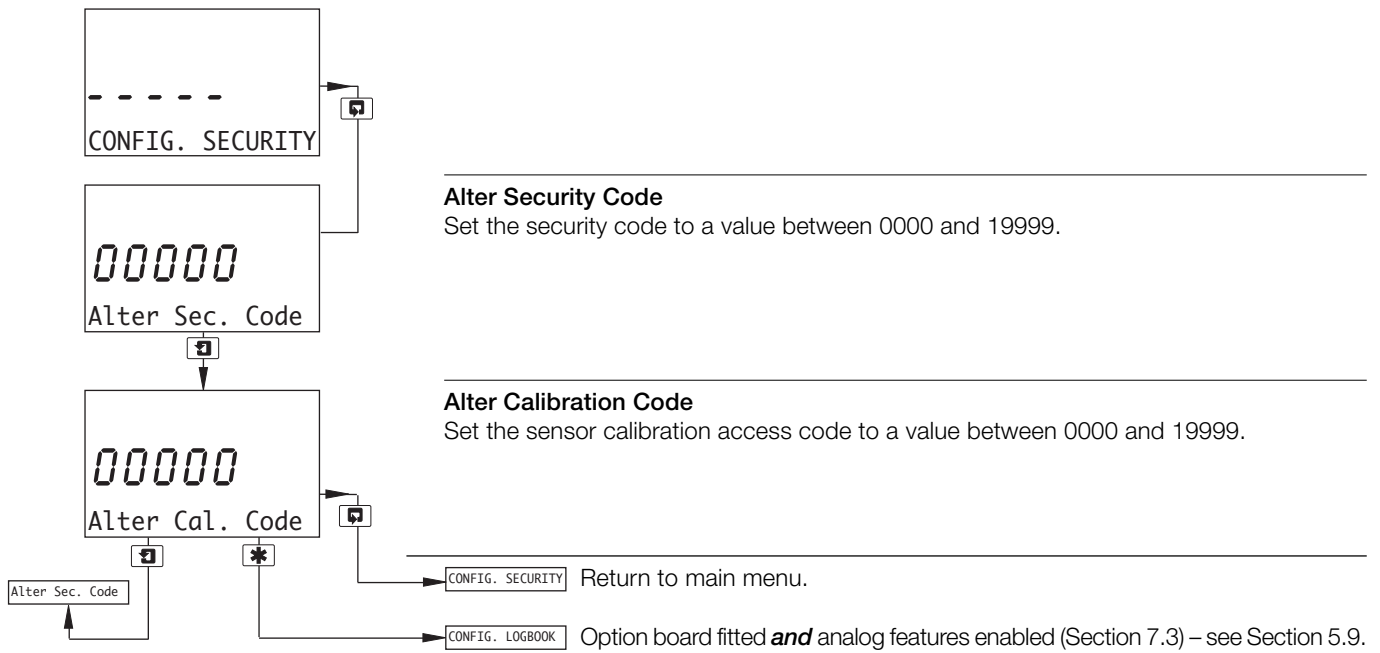

### 5.9 Configure Logbook

**Note.** The Configure Logbook function is available only if the option board is fitted **and** analog features enabled – see Section 7.3.

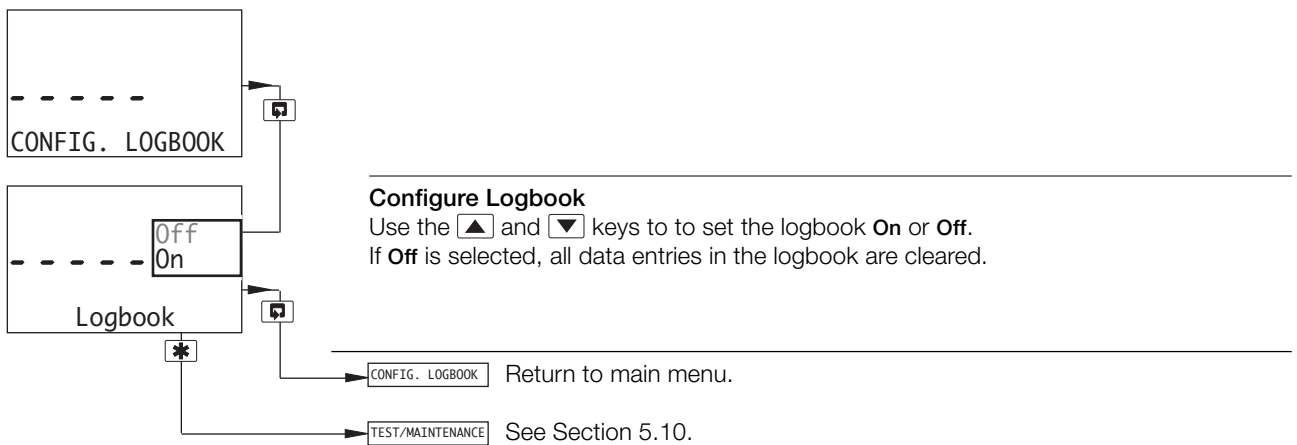

5.10 Test Outputs and Maintenance

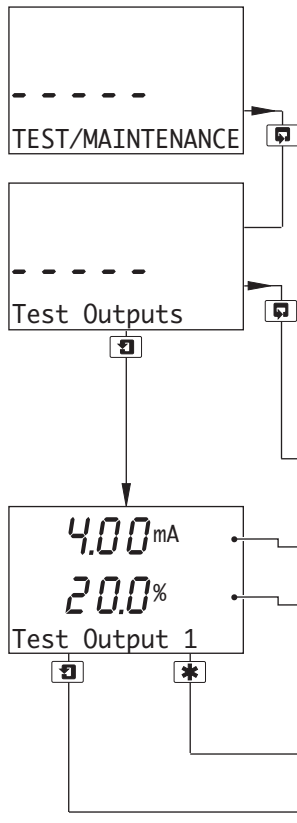

**Test Outputs**

Displays the output test details for the analog outputs.

**Note.** Outputs 3 and 4 are available only if the option board is fitted **and** analog features enabled – see Section 7.3.

**Test Output 1** frame only is shown; the format of frames for the remaining outputs is identical.

Maintenance See below.

**Test Output 1**

The theoretical output current value.

Output current as a percentage of the full range current.

Use the ▲ and ▼ keys to adjust the displayed theoretical output current value to give the output required.

FACTORY SETTINGS See Section 7.3.

Test Output 2 Test remaining outputs.

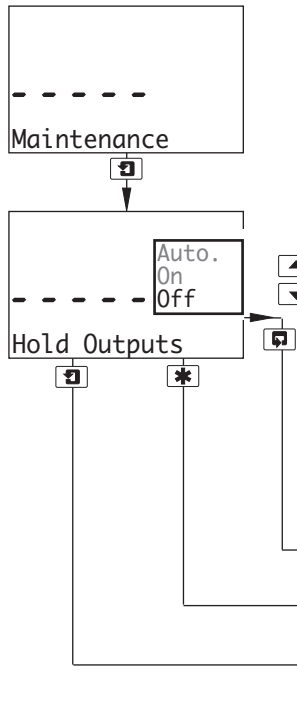

**Maintenance**

**Hold Outputs**

Enables the relay action and analog outputs to be maintained.

- Auto. – Changes in relay action and analog outputs are disabled during sensor calibration.
- On – Changes in relay action and analog outputs are disabled.
- Off – Changes in relay action and analog outputs are not disabled.

**Note.** The LEDs flash while the analyzer is in 'Hold' mode.

Load/Save Config Continued on next page.

FACTORY SETTINGS See Section 7.3.

Maintenance **Hold Outputs** set to Off or On – return to main menu.

Automatic Time **Hold Outputs** set to Auto. – continued on next page.

...5.10 Test Outputs and Maintenance

Hold Outputs  
set to Auto.

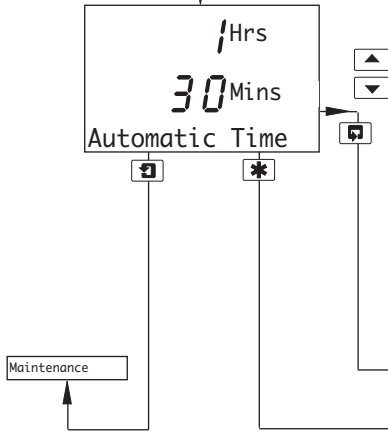

**Automatic Time**

If required, set a time period between 1 and 6 hours, in 30 minute increments, for which the outputs are held when **Hold Outputs** is set to **Auto**.

At the default setting of **None**, changes in relay action and analog outputs are disabled during sensor calibration and enabled automatically at the end of the procedure.

If a time is set, changes in relay action and analog outputs are disabled during sensor calibration, but if the calibration is not completed within the set time, the calibration is aborted, the display returns to the *Operating Page* and **CAL. ABORTED** is displayed.

Continued below.

See Section 7.3.

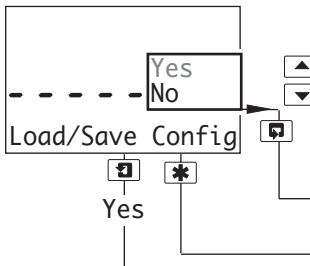

**Load/Save Configuration**

Select whether a configuration is to be loaded or saved.

**Note.** If **No** is selected, pressing the key has no effect.

Return to main menu.

See Section 7.3.

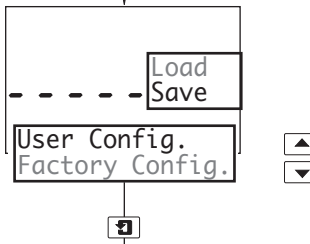

**Load User/Factory Configuration**

**Note.** Applicable only if **Load/Save Config** is set to **Yes**.

- Factory Config. – resets all the parameters in the **Configuration Pages** to the Company Standard.
- Save User Config. – saves the current configuration into memory.
- Load User Config. – reads the saved user configuration into memory.

**User Config.** and **Factory Config.** are displayed alternately if a User Configuration has been saved previously. Use the and keys to make the required selection.

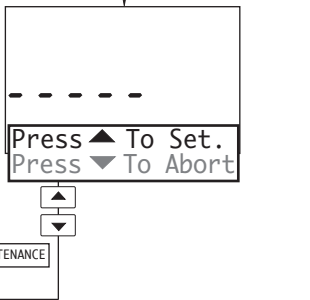

**Press ▲ to Wash** and **Press ▼ to Abort** are displayed alternately on the lower display line.

Press the appropriate key to load/save the configuration or abort the changes.

# 6 INSTALLATION

## 6.1 Siting Requirements

### Notes.

- Mount in a location free from excessive vibration, and where the temperature and humidity specification will not be exceeded.
- Mount away from harmful vapors and/or dripping fluids and ensure that it is suitably protected from direct sunlight, rain, snow and hail.s.
- Where possible, mount the analyzer at eye level to allow an unrestricted view of the front panel displays and controls.

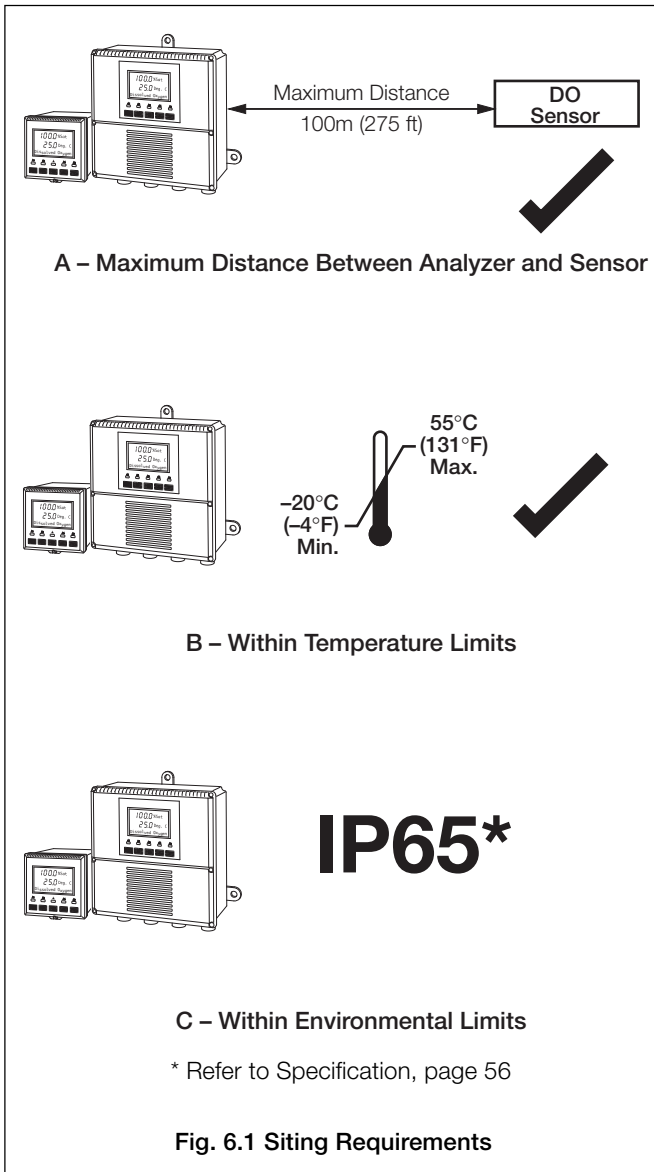

6.2 Mounting

6.2.1 Wall-/Pipe-mount Analyzers – Figs. 6.2 and 6.3

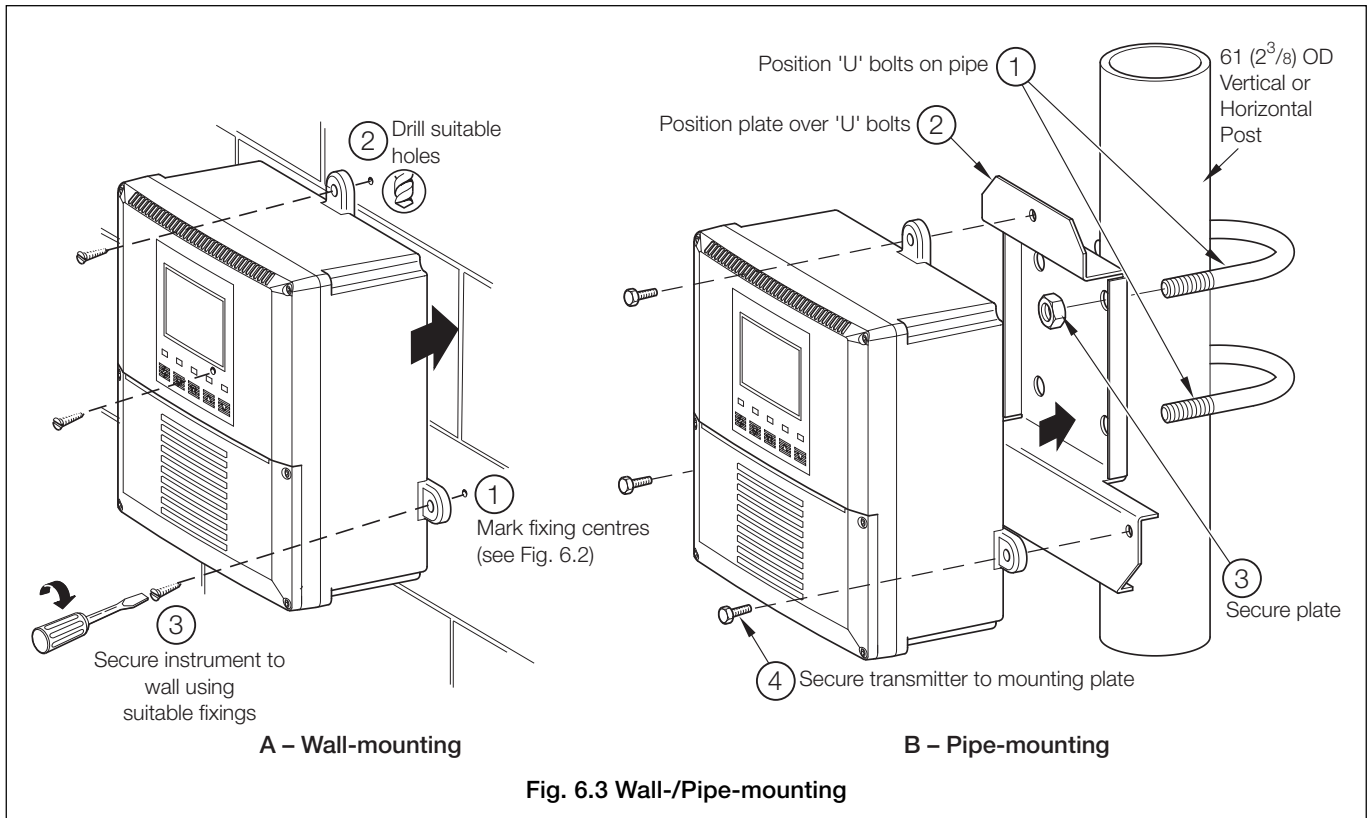
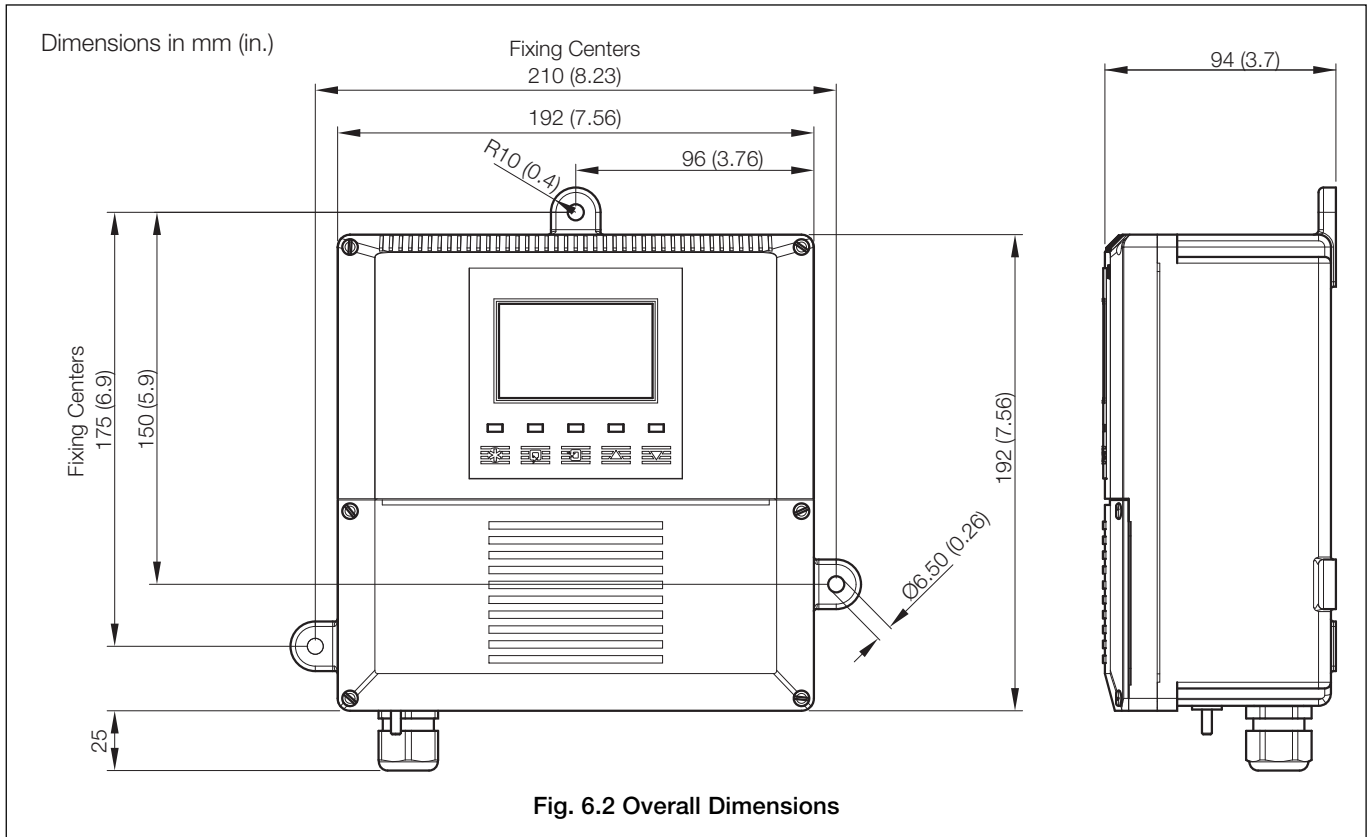

## ...6.2 Mounting

## 6.2.2 Panel-mount Analyzers – Figs. 6.4 and 6.5

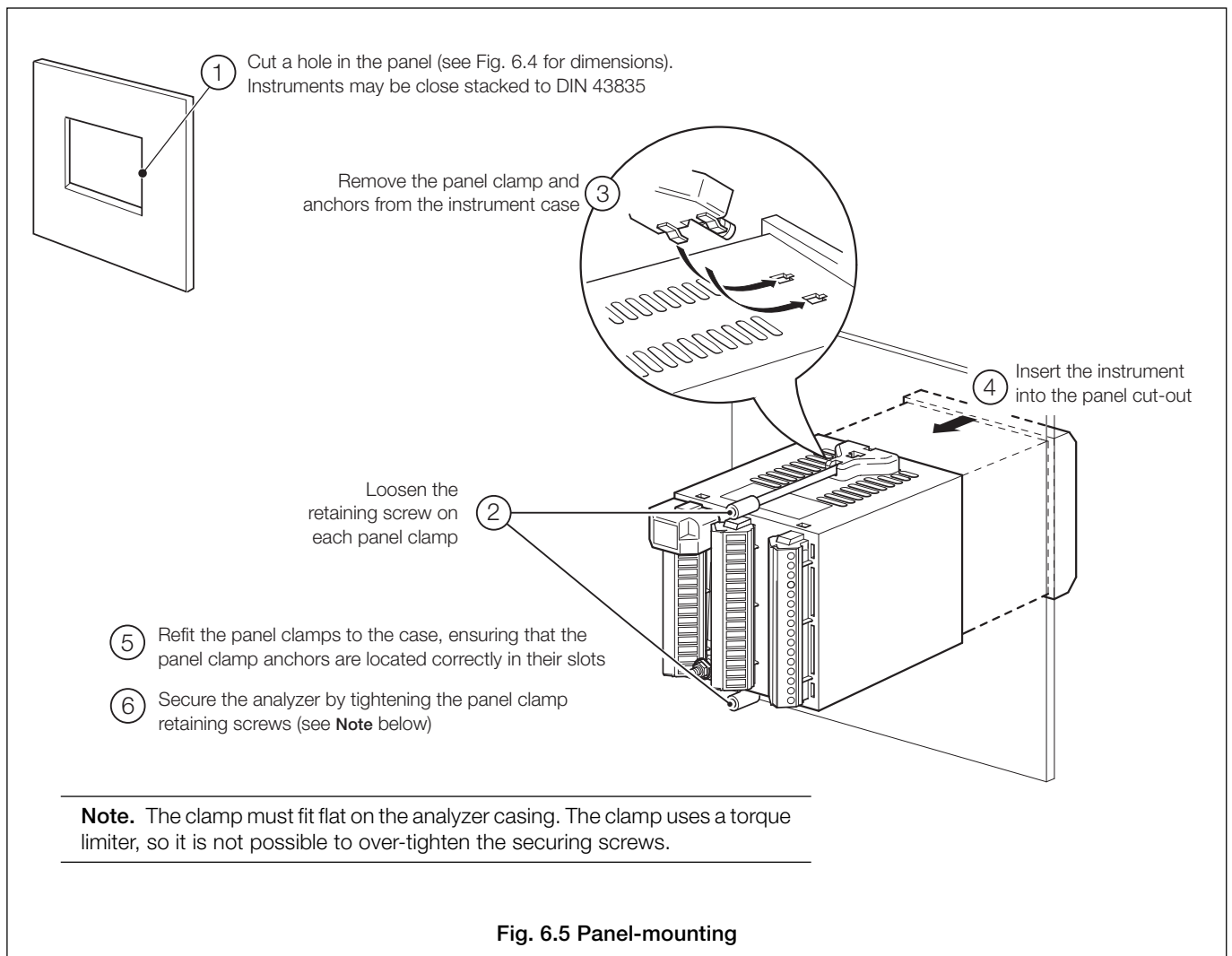
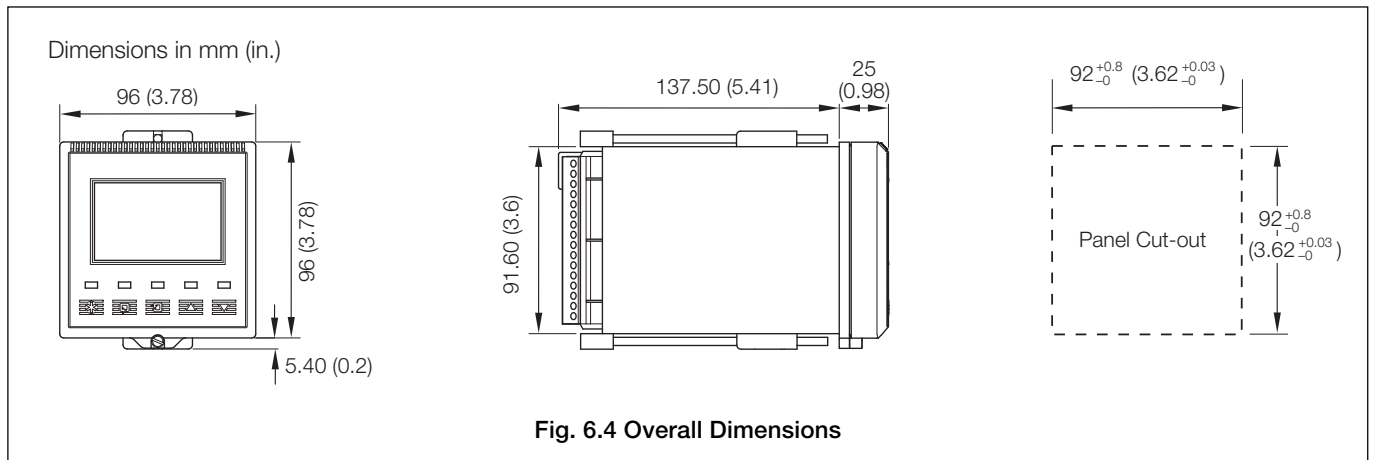

### 6.3 Electrical Connections



#### Warnings.

- The instrument is not fitted with a switch therefore a disconnecting device such as a switch or circuit breaker conforming to local safety standards must be fitted to the final installation. It must be fitted in close proximity to the instrument within easy reach of the operator and must be marked clearly as the disconnection device for the instrument.
- Remove all power from supply, relay and any powered control circuits and high common mode voltages before accessing or making any connections.
- The power supply earth (ground) **must** be connected to reduce the effects of RFI interference and ensure the correct operation of the power supply interference filter.
- The power supply earth (ground) **must** be connected to the earth (ground) stud on the analyzer case – see Fig. 6.8 (wall-/pipe-mount analyzers) or Fig. 6.10 (panel-mount analyzers).
- Use cable appropriate for the load currents. The terminals accept cables from 20 to 14 AWG (0.5 to 2.5mm<sup>2</sup>) UL Category AVL2.
- The instrument conforms to Mains Power Input Insulation Category III. All other inputs and outputs conform to Category II.
- All connections to secondary circuits must have basic insulation.
- After installation, there must be no access to live parts, e.g. terminals.
- Terminals for external circuits are for use only with equipment with no accessible live parts.
- The relay contacts are voltage-free and must be appropriately connected in series with the power supply and the alarm/control device which they are to actuate. Ensure that the contact rating is not exceeded. Refer also to Section 6.3.1 for relay contact protection details when the relays are to be used for switching loads.
- Do not exceed the maximum load specification for the selected analog output range.  
The analog output is isolated, therefore the –ve terminal must be connected to earth (ground) if connecting to the isolated input of another device.
- If the instrument is used in a manner not specified by the Company, the protection provided by the equipment may be impaired.
- All equipment connected to the instrument's terminals must comply with local safety standards (IEC 60950, EN61010-1).

#### USA and Canada Only

- The supplied cable glands are provided for the connection of signal input and ethernet communication wiring ONLY.
- The supplied cable glands and use of cable / flexible cord for connection of the mains power source to the mains input and relay contact output terminals is not permitted in the USA or Canada.
- For connection to mains (mains input and relay contact outputs), use only suitably rated field wiring insulated copper conductors rated min. 300 V, 14 AWG 90C. Route wires through suitably flexible conduits and fittings.

---

#### Notes.

- Earthing (grounding) – a stud terminal is fitted to the analyzer case for bus-bar earth (ground) connection – see Fig. 6.8 (wall-/pipe-mount analyzers) or Fig. 6.10 (panel-mount analyzers).
  - Always route signal output/sensor cell cable leads and mains-carrying/relay cables separately, ideally in earthed (grounded) metal conduit. Use twisted pair output leads or screened cable with the screen connected to the case earth (ground) stud.  
  
Ensure that the cables enter the analyzer through the glands nearest the appropriate screw terminals and are short and direct. Do not tuck excess cable into the terminal compartment.
  - Ensure that the IP65 rating is not compromised when using cable glands, conduit fittings and blanking plugs/bungs (M20 holes). The M20 glands accept cable of between 5 and 9mm (0.2 and 0.35 in.) diameter.
-

### ...6.3 Electrical Connections

#### 6.3.1 Relay Contact Protection and Interference Suppression – Fig. 6.6

If the relays are used to switch loads on and off, the relay contacts can become eroded due to arcing. Arcing also generates radio frequency interference (RFI) which can result in analyzer malfunctions and incorrect readings. To minimize the effects of RFI, arc suppression components are required; resistor/capacitor networks for AC applications or diodes for DC applications. These components must be connected across the load – see Fig 6.6.

For **AC applications** the value of the resistor/capacitor network depends on the load current and inductance that is switched. Initially, fit a 100R/0.022 $\mu$ F RC suppressor unit (part no. B9303) as shown in Fig. 6.6A. If the analyzer malfunctions (locks up, display goes blank, resets etc.) the value of the RC network is too low for suppression and an alternative value must be used. If the correct value cannot be obtained, contact the manufacturer of the switched device for details on the RC unit required.

For **DC applications** fit a diode as shown in Fig. 6.6B. For general applications use an IN5406 type (600V peak inverse voltage at 3A).

**Note.** For reliable switching the minimum voltage must be greater than 12V and the minimum current greater than 100mA.

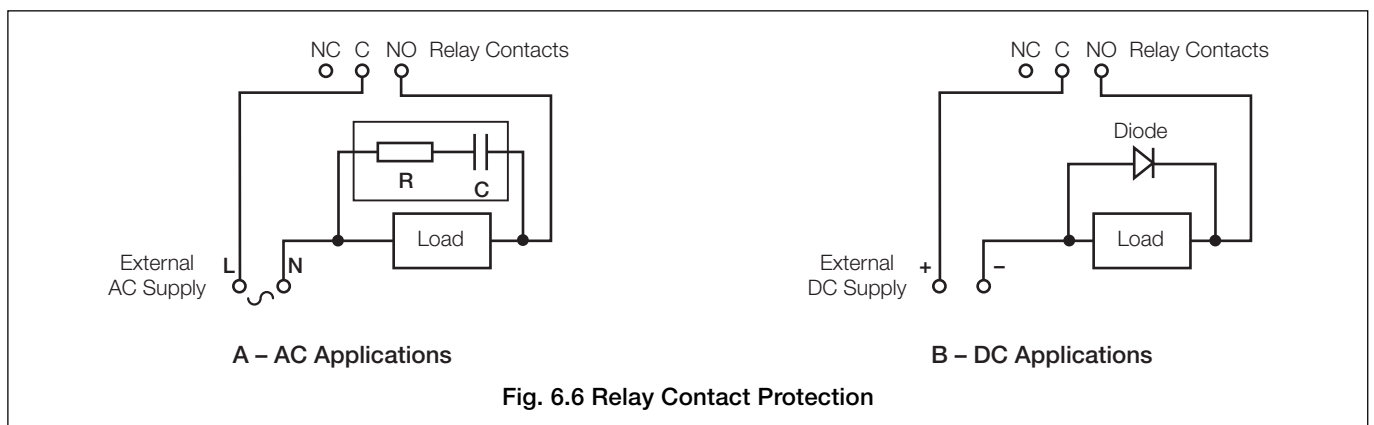

## ...6 INSTALLATION

### ...6.3 Electrical Connections

#### 6.3.2 Cable Entry Knockouts, Wall-/Pipe-mount Analyzer – Fig. 6.7

The analyzer is supplied with 7 cable glands, one fitted and six to be fitted, as required, by the user – see Fig. 6.7.

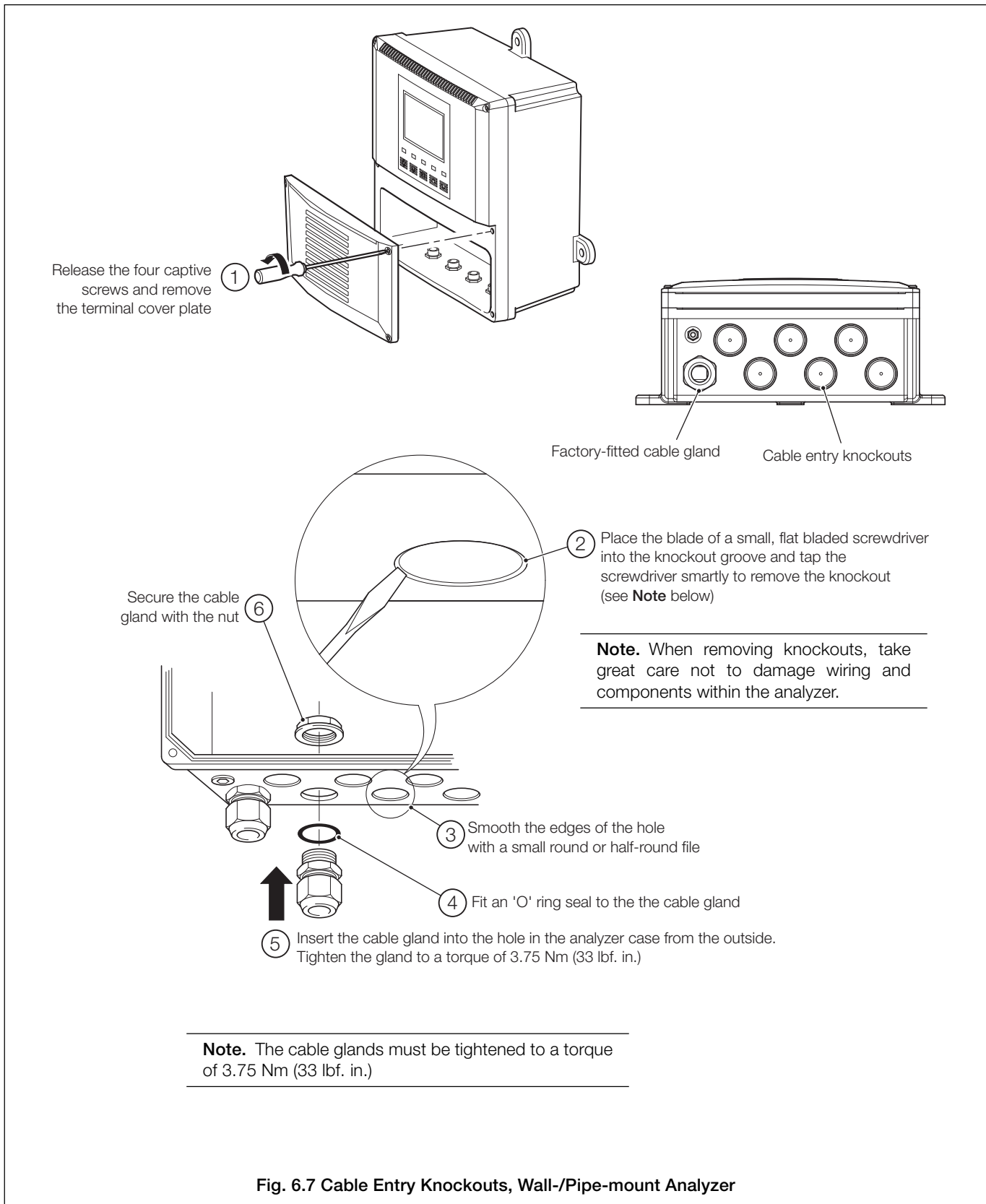

## 6.4 Wall-/Pipe-mount Analyzer Connections

### 6.4.1 Access to Terminals – Fig. 6.8

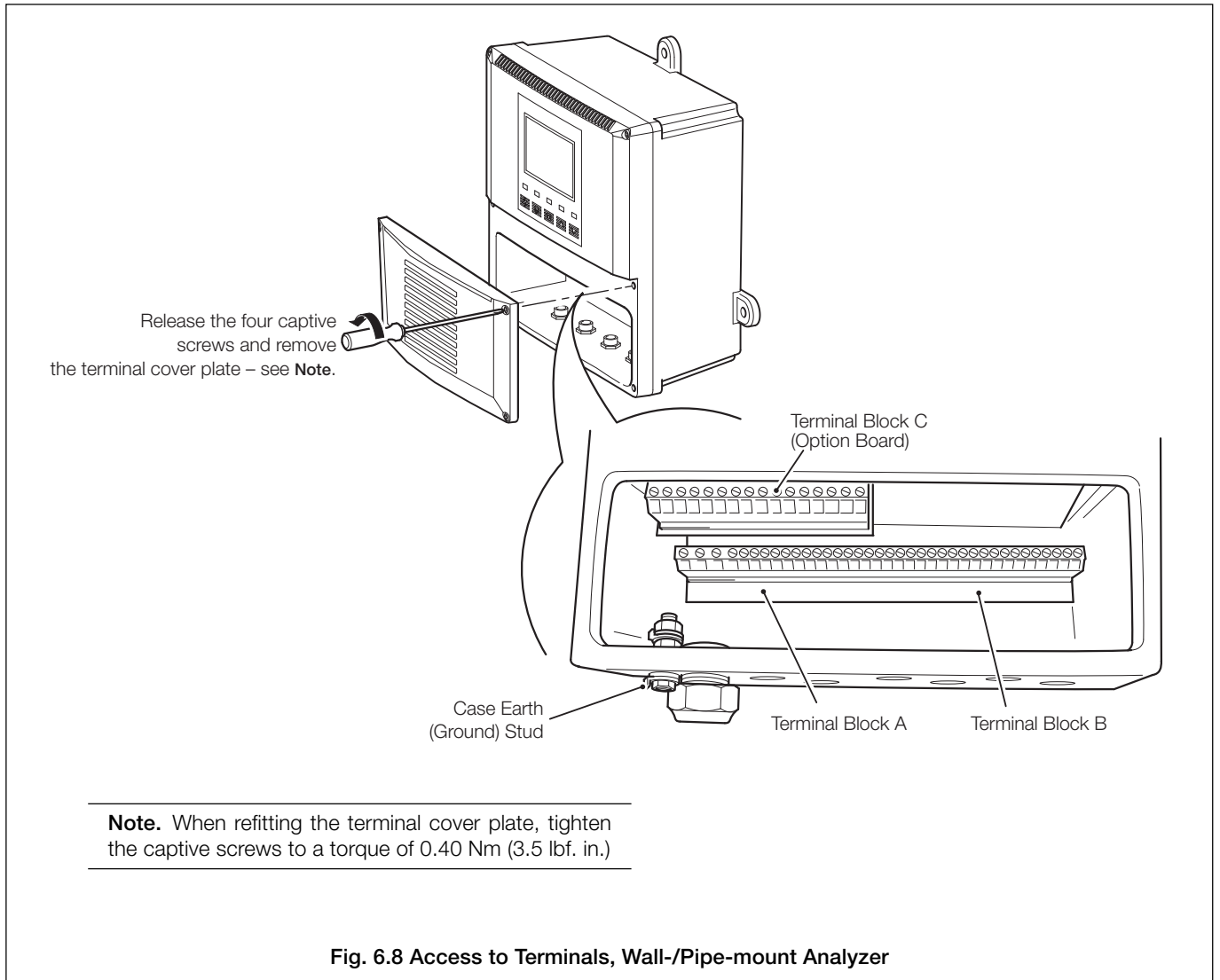

## ...6.6 INSTALLATION

### ...6.4 Wall-/Pipe-mount Analyzer Connections

#### 6.4.2 Connections – Fig. 6.9

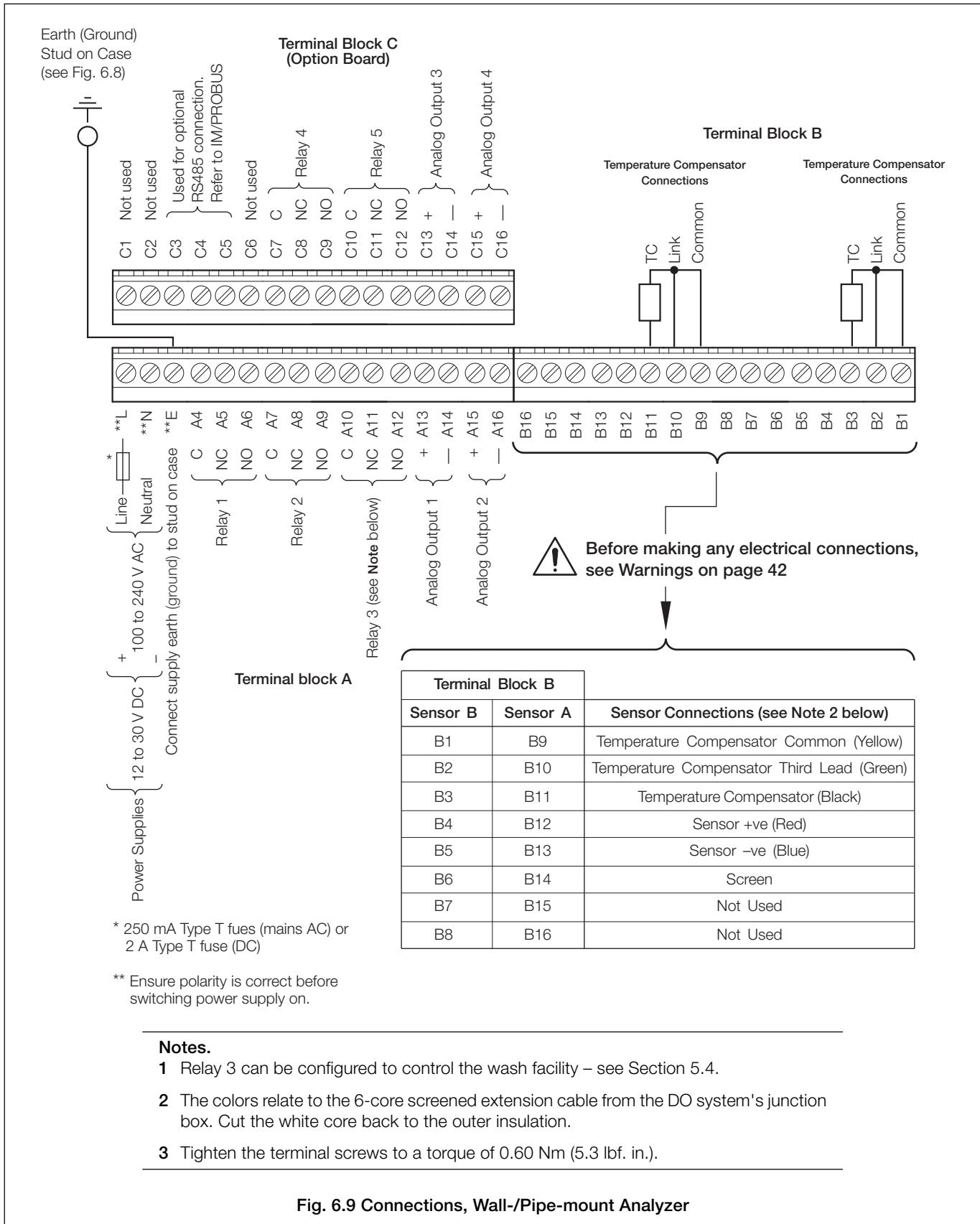
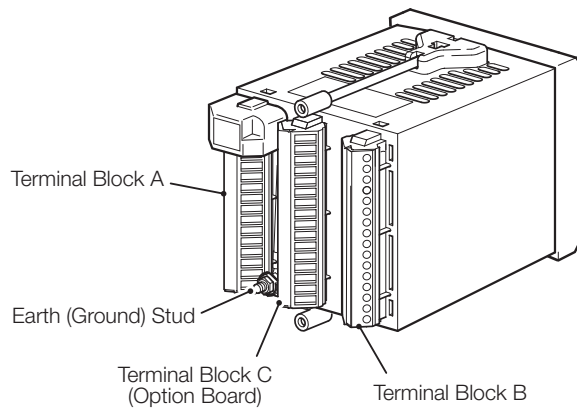

Fig. 6.9 Connections, Wall-/Pipe-mount Analyzer

## 6.5 Panel-mount Analyzer Connections

### 6.5.1 Access to Terminals – Fig. 6.10



**Fig. 6.10 Access to Terminals, Panel-mount Analyzers**

## ...6.6 INSTALLATION

### ...6.5 Panel-mount Analyzer Connections

#### 6.5.2 Connections – Fig. 6.11

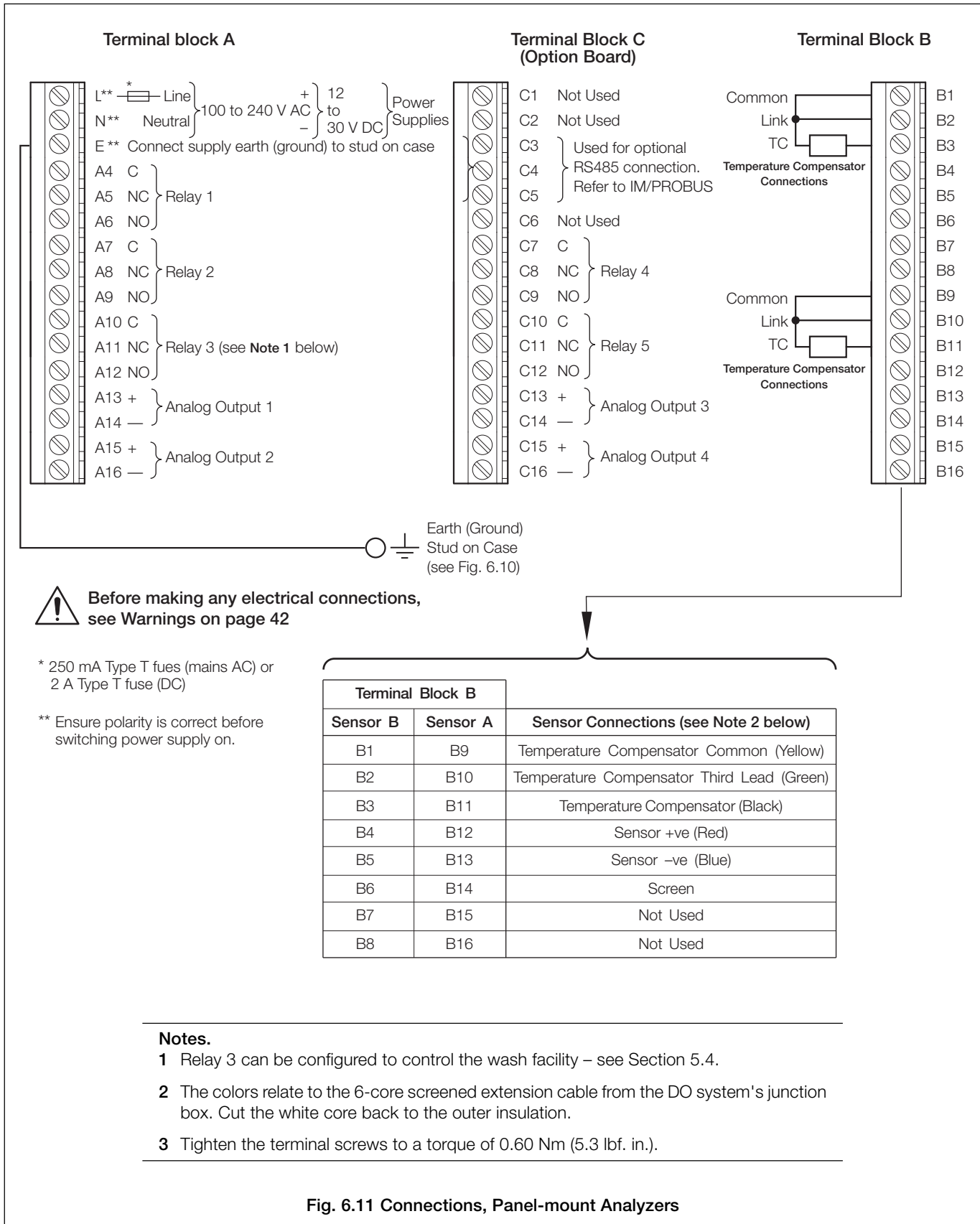

Fig. 6.11 Connections, Panel-mount Analyzers

## 7 CALIBRATION

### Notes.

- The analyzer is calibrated by the Company prior to dispatch and the Factory Settings pages are protected by an access code.
- Routine recalibration is not necessary – high stability components are used in the analyzer's input circuitry and, once calibrated, the Analog-to-Digital converter chip self-compensates for zero and span drift. It is therefore unlikely that the calibration will change over time.
- **Do Not** attempt recalibration without first contacting ABB.
- **Do Not** attempt recalibration unless the input board has been replaced or the Factory Calibration tampered with.
- Before attempting recalibration, test the analyzer's accuracy using suitably calibrated test equipment – see Sections 7.1 and 7.2.

### 7.1 Equipment Required

- a) Current source (sensor simulator): 0 to 100 $\mu$ A (in increments of 0.1 $\mu$ A), accuracy  $\pm$ 0.1%.
- b) Decade resistance box (Pt100 temperature input simulator): 0 to 1k $\Omega$  (in increments of 0.01 $\Omega$ ), accuracy  $\pm$ 0.1%.
- c) Digital milliammeter (current output measurement): 0 to 20mA.

**Note.** Decade resistance boxes have an inherent residual resistance that may range from a few m $\Omega$  up to 1 $\Omega$ . This value must be taken into account when simulating input levels, as should the overall tolerance of the resistors within the boxes.

### 7.2 Preparation

- a) Switch off the supply and disconnect the sensor(s), temperature compensator(s) and current output(s) from the analyzer's terminal blocks.
- b) Sensor A – Fig. 7.1:
  - 1) Link terminals B9 and B10.
  - 2) Connect the current source to terminals B12 (+ve) and B13 (–ve) to simulate the sensor input. Connect the current source earth (ground) to the Case Earth (Ground) Stud – see Fig. 6.8 (wall-/pipe-mount analyzer) or Fig. 6.10 (panel-mount analyzer).
  - 3) Connect the 0 to 10k $\Omega$  decade resistance box to terminals B9 and B11 to simulate the Pt100.

Sensor B:

- 1) Link terminals B1 and B2 (dual input analyzers only) – Fig. 7.1.
  - 2) Connect the current source to terminals B4 (+ve) and B5 (–ve) to simulate the sensor input. Connect the current source earth (ground) to the Case Earth (Ground) Stud – see Fig. 6.8 or (wall-/pipe-mount analyzer) or Fig. 6.10 (panel-mount analyzer).
  - 3) Connect the 0 to 10k $\Omega$  decade resistance box to terminals B1 and B3 to simulate the Pt100.
- c) Connect the milliammeter to the analog output terminals.
  - d) Switch on the supply and allow ten minutes for the circuits to stabilize.
  - d) Select the **FACTORY SETTINGS** page and carry out Section 7.3.

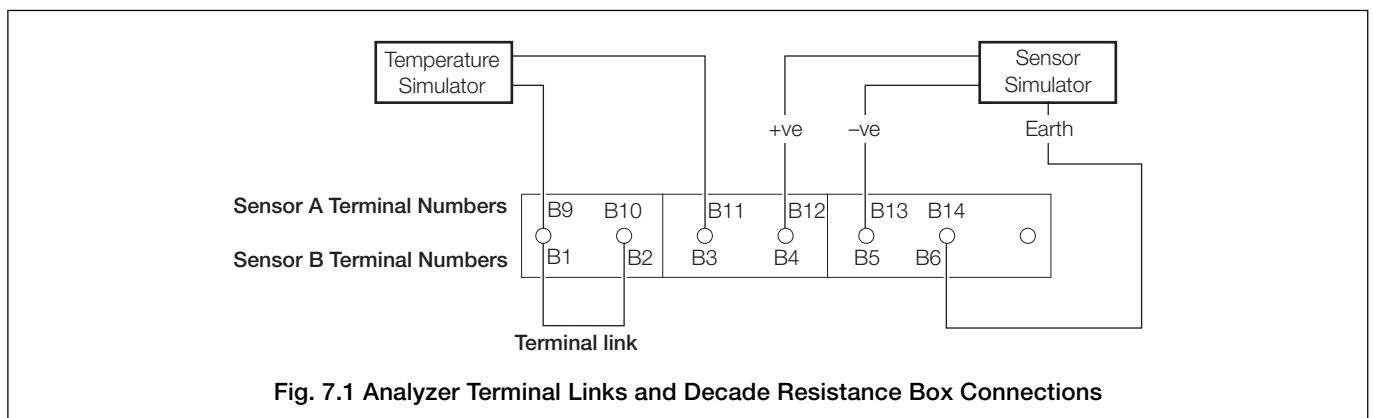

Fig. 7.1 Analyzer Terminal Links and Decade Resistance Box Connections

7.3 Factory Settings

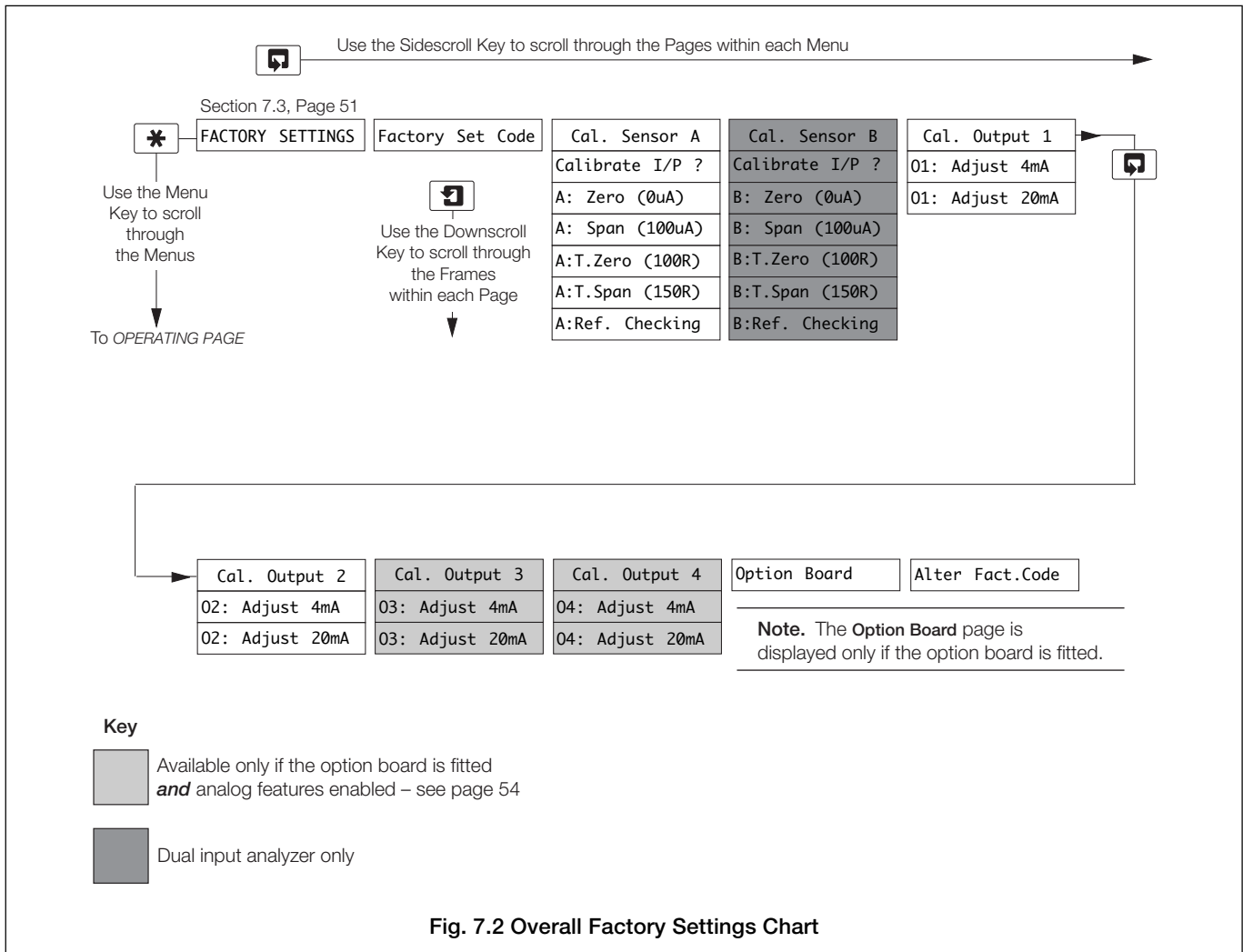
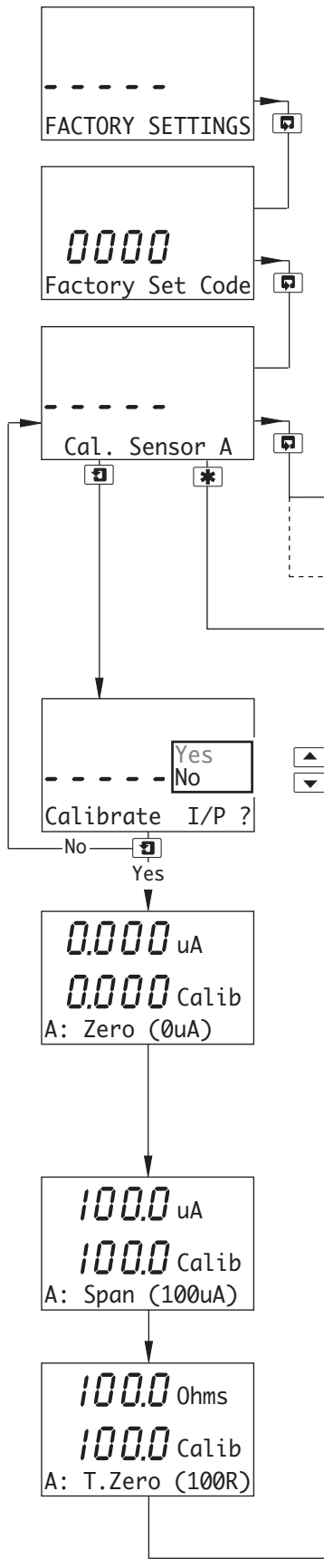

Fig. 7.2 Overall Factory Settings Chart

...7.3 Factory Settings



**Factory Settings Access Code**

Enter the required code number (between 0000 and 19999) to gain access to the factory settings. If an incorrect value is entered, access to subsequent frames is prevented and the display reverts to the top of the page.

**Calibrate Sensor A**

**Note.** The values in the display lines for sensor calibration are shown as examples only – the actual values obtained will differ.

- Cal. Sensor B    Sensor B calibration (dual input analyzers only) is identical to Sensor A calibration.
- Cal. Output 1    Single input analyzers only – see page 53.
- Dissolved Oxygen } Operating Page – see Section 2.3.
- Dual D.O.        }

**Calibrate Input for Sensor A ?**

If calibration is required select **Yes** otherwise select **No**.

**Note.** To abort calibration, press the key again at any time before calibration is complete – see next page.

**Current Zero (0µA)**

Set the sensor simulator reading to 0µA.

The display advances automatically to the next step once a stable and valid value is recorded.

**Note.** The upper 6-segment display shows the measured value. Once the signal is within range the lower 6-segment display shows the same value and **Calib** is displayed to indicate that calibration is in progress.

**Span (100µA)**

Set the sensor simulator reading to 100µA.

The display advances automatically to the next step once a stable and valid value is recorded.

**Temperature Zero**

Set the temperature simulator reading to 100Ω.

The display advances automatically to the next step once a stable and valid value is recorded.

A: T.Span (150R)    Continued on next page.

## ...7 CALIBRATION

### ...7.3 Factory Settings

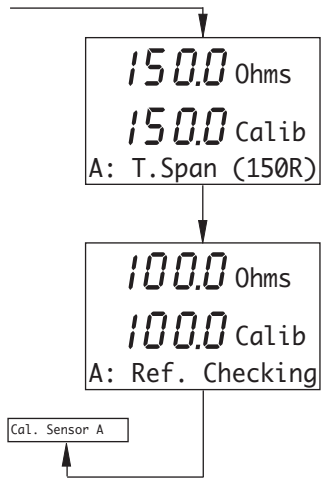

#### Temperature Span (150R)

Set the temperature simulator to 150Ω

The display advances automatically to the next step once a stable and valid value is recorded.

#### Reference Resistance Checking

The analyzer calibrates the internal reference resistance automatically to compensate for changes in ambient temperature.

The display returns automatically to **Cal. Sensor A** once a stable and valid value is recorded.

#### Abort Calibration

Select **Yes** or **No**.

**Yes** selected:

→ **A: T.Zero (100R)** – **before** completion of **A: Span (100uA)** frame – calibration advances to **A: T.Zero (100R)** and continues.

→ **CAL. SENSOR A** – **after** completion of **A: Span (100uA)** frame – the display returns to the **Calibrate Sensor A** page.

**No** selected – calibration continues from the point at which the **[F]** key was pressed.

...7.3 Factory Settings

**Calibrate Output 1**

**Note.** When adjusting the 4 and 20mA output values, the display reading is unimportant and is used only to indicate that the output is changing when the ▲ and ▼ keys are pressed.

Cal. Output 2 See below.

---

**Adjust 4mA**

Use the ▲ and ▼ keys to set the milliammeter reading to 4mA.

**Note.** The analog output range selected in **Configure Outputs** (Section 5.5) does not affect the reading.

---

**Adjust 20mA**

Use the ▲ and ▼ keys to set the milliammeter reading to 20mA.

**Note.** The analog output range selected in **Configure Outputs** (Section 5.5) does not affect the reading.

Cal. Output 1

Cal. Output 2 See below.

Dissolved Oxygen  
Dual D.O. } *Operating Page – see Section 2.3.*

**Calibrate Output 2**

**Note.** Output 2 calibration is identical to Output 1 calibration.

Cal. Output 3 Option board fitted **and** analog features enabled – continued on next page.  
Option Board Option board fitted, additional features disabled – continued on next page.  
Alter Fact. Code Option board not fitted – continued on next page.

---

Cal. Output 3 Option board fitted **and** analog features enabled – continued on next page.  
Option Board Option board fitted, additional features disabled – continued on next page.  
Alter Fact. Code Option board not fitted – continued on next page.

Dissolved Oxygen  
Dual D.O. } *Operating Page – see Section 2.3.*

...7.3 Factory Settings

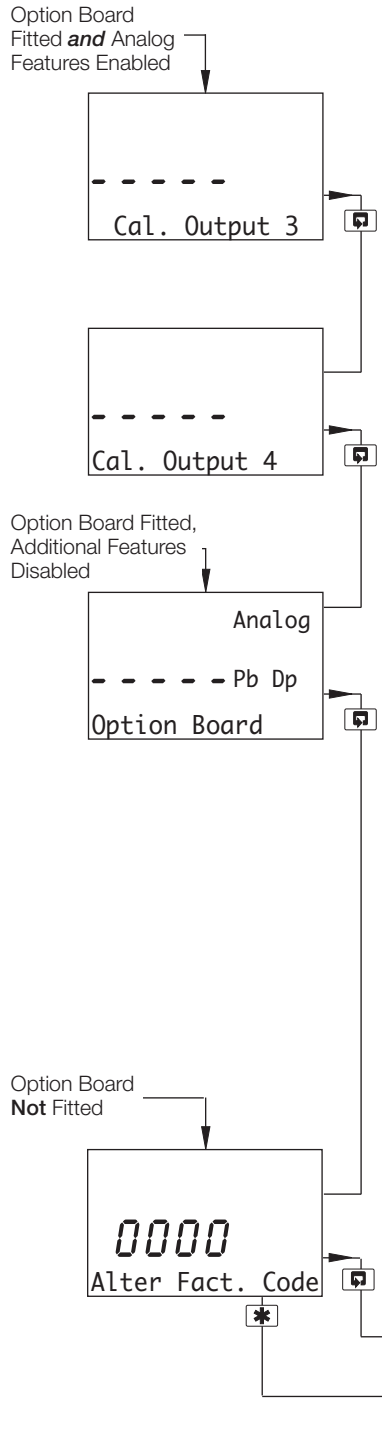

Calibrate Output 3

Notes.

- Output 3 (and Output 4) calibration is applicable only if the option board is fitted **and** analog features enabled – see below.
- Output 3 calibration is identical to Output 2 calibration.

Calibrate Output 4

**Note.** Output 4 calibration is identical to Output 3 calibration.

Configure Option Board

Notes.

- This parameter is displayed only if an option board is fitted.
- The software detects if an option board is fitted but cannot detect the additional features available.
- If an option board is fitted, the correct selection must be made below to enable use of the available features. If an incorrect selection is made, the software menus and frames associated with that option are displayed in the Operating and Configuration pages but the features do not work.

Use the ▲ and ▼ keys to enable the features for the type of option board(s) fitted:

- Analog – Analog features enabled (comprising two additional analog outputs, two additional alarm relays, clock and logbook facility).
- Pb Dp – PROFIBUS-DP digital communications features enabled.
- Analog + Pb Dp – Both analog and PROFIBUS-DP features enabled.

Alter Factory Code

Set the factory settings access code to a value between 0000 and 19999.

## 8 SIMPLE FAULT FINDING

### 8.1 Error Messages

If erroneous or unexpected results are obtained the fault may be indicated in the *Operating Page* by an error message – see Table 8.1. However, some faults may cause problems with analyzer calibration or give discrepancies when compared with independent laboratory measurements.

Error Message	Possible Cause/Remedy
A: FAULTY PT100	Temperature compensator/associated connections for Sensor A are either open circuit or short circuit.
B: FAULTY PT100	Temperature compensator/associated connections for Sensor B are either open circuit or short circuit.
A: High Temp	The temperature of Sensor A has exceeded 40°C (104°F).
B: High Temp	The temperature of Sensor B has exceeded 40°C (104°F).
* Warning-Offset	The $\mu\text{A}$ value in the <b>Adjust Zero</b> frame has been adjusted beyond the range $-0.100$ to $0.600\mu\text{A}$ – see Section 4.1. Ensure sensor connections are clean and dry. Check zero calibration solution (if used) – see Appendix A3.1. Repeat the calibration. If the fault persists, replace the sensor.
* Warning-Low O/P	The <b>Slope</b> value in the <b>Adjust Span</b> frame has been adjusted above 2.000 – see Section 4.1. The sensor is becoming fatigued. Order a replacement.
* Out Of Range	The $\mu\text{A}$ value in the <b>Adjust Zero</b> frame has been adjusted to the maximum of its range ( $\pm 2.000\mu\text{A}$ ) – see Section 4.1. Adjustment outside this range is not possible. Check zero calibration solution (if used) – see Appendix A3.1. Repeat the calibration. If the fault persists, replace the sensor. <b>OR</b> The <b>Slope</b> value in the <b>Adjust Span</b> frame has been adjusted to the maximum of its range (0.400 to 2.500) – see Section 4.1. Adjustment outside this range is not possible. The sensor is exhausted, replace the sensor.
A: Sens O/P ##	Sensor A is becoming fatigued. Order a replacement.
B: Sens O/P ##	Sensor B is becoming fatigued. Order a replacement.
A: Sens O/P # (Note. # flashing)	Calibration of Sensor A has failed. Repeat the calibration. If the fault persists, replace the sensor.
B: Sens O/P # (Note. # flashing)	Calibration of Sensor B has failed. Repeat the calibration. If the fault persists, replace the sensor.
WASH INHIBITED	<b>Wash Function</b> is set to <b>Off</b> in the <b>Operating Page</b> . Set <b>Wash Function</b> to <b>On</b> – see Section 2.3.3.

\* Manual calibration type only

**Table 8.1 Error Messages**

### 8.2 No Response to DO Changes

The majority of problems are associated with the DO sensor. Replace the sensor as an initial check – refer to the appropriate instruction manual. It is also important that all program parameters have been set correctly and have not been altered inadvertently – see Section 5.

If the above checks do not resolve the fault:

- Carry out an electrical calibration as detailed in Section 7 and check that the instrument responds correctly to the current input.

Failure to respond to the input usually indicates a fault with the analyzer, which must be returned to the Company for repair.

- If the response in a) is correct, select the *Operating Page* and set the current source to a value which gives an on-scale DO reading on the analyzer. Make a note of the current source setting and the DO reading. Reconnect the sensor cable and connect the current source to the sensor end of the cable. Set the same current value on the source and check that the analyzer displays the noted reading in this configuration.

If check a) is correct but check b) fails, check the cable connections and condition. If the response for both checks is correct, replace the sensor.

### 8.3 Checking the Temperature Input

Check the analyzer responds to a temperature input. Disconnect the Pt100 leads and connect a suitable resistance box directly to the analyzer inputs – see Section 7.2. Check the analyzer displays the correct values as set on the resistance box – see Table 8.2.

Incorrect readings usually indicate an electrical calibration problem. Re-calibrate the analyzer as detailed in Section 7.3.

Temperature		Pt100 Input Resistance ( $\Omega$ )
$^{\circ}\text{C}$	$^{\circ}\text{F}$	
0	32	100.00
10	50	103.90
20	68	107.79
25	77	109.73
30	86	111.67
40	104	115.54
50	122	119.40
60	140	123.24
70	158	127.07
80	176	130.89
90	194	134.70
100	212	138.50
130.5	267	150.00

**Table 8.2 Temperature Readings for Resistance Inputs**

---

# SPECIFICATION

---

## Dissolved Oxygen – AX480, AX488 and AX468

### Range

Programmable 0 ... 250% saturation, 0 ... 25 mg<sup>l</sup><sup>-1</sup> or 0 ... 25ppm

### Minimum span

0 ... 2 mg<sup>l</sup><sup>-1</sup> or ppm

0 ... 20% saturation

### Units of measure

% saturation, mg<sup>l</sup><sup>-1</sup> and ppm

### Resolution

0.1 (% saturation), 0.01 (mg<sup>l</sup><sup>-1</sup>) or 0.01 (ppm)

### Accuracy

1 (% saturation), 0.1 (mg<sup>l</sup><sup>-1</sup>) or 0.1 (ppm)

### Operating temperature range

0 ... 40 °C (32 ... 104 °F)

### Temperature sensor input

3-wire Pt100

### Salinity correction

Automatic over the range 0 ... 40 parts per thousand

### Auto sensor life indicator

Indicates conditions of remaining sensor life

---

## pH/Redox – AX468 only

### Inputs

One pH or mV input and solution earth

One temperature sensor

Enables connection to glass or enamel pH and reference sensors and Redox (ORP) sensors

### Input resistance

Glass > 1 x 10<sup>13</sup>Ω

Reference 1 x 10<sup>13</sup>Ω

### Range

-2 ... 16 pH or -1200 ... +1200 mV

### Minimum span

Any 2 pH span or 100 mV

### Resolution

0.01 pH

### Accuracy

0.01 pH

### Temperature compensation modes

Automatic or manual Nernstian compensation

Range -10 ... 200 °C (14 ... 392 °F)

Process solution compensation with configurable coefficient

Range -10 ... 200 °C (14 ... 392 °F)

adjustable -0.05 ... 0.02%/ °C (-0.02 ... 0.009%/ °F)

---

### Temperature sensor

Programmable Pt100 (3-wire), Pt1000 & Balco 3k.

### Calibration Ranges

Check value (zero point) 0 ... 14 pH

### Slope

Between 40 and 105% (low limit user-configurable)

---

## Electrode Calibration Modes

### Calibration with auto-stability checking

Automatic one or two point calibration selectable from:

ABB

DIN

Merck

NIST

US Tech

Two x user-defined buffer tables for manual entry or

Two-point calibration or single-point process calibration

---

## Display

### Type

Dual 5-digit, 7-segment, backlit LCD

### Information

16-character, single line dot-matrix

### Energy-saving function

Backlit LCD configurable as ON or Auto Off after 60s

### Logbook\*

Electronic record of major process events and calibration data

### Real-time clock\*

Records time for logbook and auto-manual functions

\*Available if option board is fitted

---

## Sensor Cleaning Function

### Configurable cleaning action relay contact

Continuous or

Pulse in 1s on and off times

### Frequency

5 minutes ... 24 hours, programmable in 15 minute increments up to

1 hour then in 1 hour increments for 1 ... 24 hours

### Duration

15s ... 10 minutes, programmable in 15s increments up to

1 minute then in 1 minute increments up to 10 minutes

### Recovery period

30s ... 5 minutes, programmable in 30s increments

---

---

## Relay Outputs – On/Off

### Number of relays

Three supplied as standard or five with option board fitted

### Number of set points

Three supplied as standard or five with option board fitted

### Set point adjustment

Configurable as normal or failsafe high/low or diagnostic alert

### Hysteresis of reading

Programmable 0 ... 5% in 0.1% increments

### Delay

Programmable 0 ... 60s in 1s intervals

### Relay contacts

Single-pole changeover

### Rating 5A, 115/230V AC, 5A DC

Insulation

2kV RMS contacts to earth/ground

---

## Analog Outputs

### Number of current outputs (fully isolated)

Two supplied as standard or four with option board fitted

### Output ranges

0 ... 10 mA, 0 ... 20 mA or 4 ... 20 mA

Analog output programmable to any value between 0 and 22 mA to indicate system failure

### Accuracy

±0.25% FSD, ±0.5% of reading (whichever is the greater)

### Resolution

0.1% at 10 mA, 0.05% at 20 mA

### Maximum load resistance

750Ω at 20 mA

### Configuration

Can be assigned to either measured variable or either sample temperature

---

## Digital Communications

### Communications

Profibus DP (with option board fitted)

## Control Function – AX480 Only

### Controller Type

P, PI, PID (Configurable)

---

## Control Outputs

### Output

Can be assigned a maximum of two relays, two analog outputs or one of each

### Analog

Current output control (0 ... 100%)

### Time proportioning cycle time

1.0 ... 300.0s, programmable in increments of 0.1s

### Pulse frequency

1 ... 120 pulses per minute, programmable in increments of 1 pulse per minute

### Controller action

Direct or reverse

### Proportional band

0.1 ... 999.9%, programmable in increments of 0.1%

### Integral action time (Reset)

1 ... 7200s, programmable in increments of 1s (0 = Off)

### Derivative

0.1 ... 999.9s programmable in increments of 0.1s, only available for single set point control

### Auto/Manual

User-programmable

---

## Access to Functions

### Direct keypad access

Measurement, maintenance, configuration, diagnostics or service functions

Performed without external equipment or internal jumpers

### Mechanical Data

#### Wall-/Pipe-mount versions

IP65 (not evaluated under UL certification)

Dimensions (height, width, depth) 192 x 230 x 94 mm  
(7.56 x 9.06 x 3.7 in)

Weight 1 kg (2.2 lb)

#### Panel-mount versions

IP65 (front only)

Dimensions (height, width, depth) 96 x 96 x 162 mm  
(3.78 x 3.78 x 6.38 in)

Weight 0.6kg (1.32 lb)

#### Cable Entry Types

Standard – 5 or 7 x M20 cable glands

N. American – 7 x knockouts suitable for 1/2 in. Hubble gland

---

### Power Supply

#### Voltage requirements

100 to 240 V AC 50/60 Hz  
(90 V Min. to 264 V Max. AC)

12 to 30 V DC

#### Power consumption

10 W

#### Insulation

Mains to earth (line to ground) 2kV RMS

---

### Environmental Data

#### Operating temperature limits

-20 to 55 °C (-4 ... 131 °F)

#### Storage temperature limits

-25 to 75 °C (-13 ... 167 °F)

#### Operating humidity limits

Up to 95%RH non condensing

### EMC

#### Emissions and immunity

Meets requirements of:

EN61326 (for an industrial environment)

EN50081-2

EN50082-2

---

### Approvals, Certification and Safety

#### Safety approval

UL

#### CE Mark

Covers EMC & LV Directives (including latest version EN 61010)

#### General safety

EN61010-1

Overvoltage Class II on inputs and outputs

Pollution category 2

---

### Languages

#### Languages configurable

English

French

German

Italian

Spanish

## APPENDIX A

### A1 Oxygen Solubility in Pure Water

Table A1 gives values for the solubility of oxygen in pure water at various temperatures. The solubility values are given in mg/l (ppm) and relate to pure water in equilibrium with water vapor-saturated normal air at the standard atmospheric pressure of 760 mmHg.

**Note.** The instrument compensates automatically for solubility in pure water variations due to temperature, using the values stated in Table A1.

Temperature °C	Solubility in Pure Water (ppm)
0	14.59
1	14.19
2	13.81
3	13.44
4	13.08
5	12.75
6	12.42
7	12.12
8	11.82
9	11.54
10	11.27
11	11.01
12	10.75
13	10.52
14	10.28
15	10.07
16	9.85
17	9.64
18	9.44
19	9.25
20	9.07
21	8.90
22	8.73
23	8.55
24	8.40
25	8.24
26	8.08
27	7.94
28	7.80
29	7.66
30	7.54
31	7.41
32	7.28
33	7.15
34	7.04
35	6.93
36	6.82
37	6.71
38	6.61
39	6.51
40	6.41

This table is abstracted from Table IVb of 'International Oceanographic Tables' volume 2, National Institute of Oceanography of Great Britain and UNESCO, 1973 (0 to 35°C) and from R. Weiss, Deep Sea Res., 1970 17, 721 (36 to 40°C).

**Table A1 Oxygen Solubility in Pure Water**

### A2 Correction for Salinity

Automatic correction for the effect of salinity on oxygen solubility is available for the measurement of dissolved oxygen concentrations in saline water, provided the salinity value of the water is known and is constant. Correction is applied by entering the known value of salinity, in parts per thousand, in the **A: Salinity** frame (see Section 5.3, page 22) after the instrument has been calibrated.

Automatic salinity correction is based on data given in 'International Oceanographic Tables', Volume 2 (National Institute of Oceanography of Great Britain and UNESCO, 1973) and is applicable only to sea or estuarine waters. For waters containing significant amounts of dissolved salts other than sodium chloride, it may be necessary to determine appropriate oxygen solubility values experimentally, e.g. by saturating aliquots of the water with air at various temperatures, spanning the required measurement range, and determining the resulting dissolved oxygen concentrations titrimetrically. The analyzer can then be used to measure both % saturation and temperature. The required oxygen concentration can be calculated from:

$$\text{concentration} = S_x \left[ \frac{\% \text{ Saturation}}{100} \right] \text{ ppm}$$

where  $S_x$  = experimentally determined oxygen solubility, mg/l(ppm), at measurement temperature.

### A3 DO Calibration

---

**Note.** Both the oxygen and the temperature sensors must be exposed to the calibration medium.

---

#### A3.1 Zero Calibration

A 5% sodium sulphite solution is required that must be prepared well in advance by dissolving 5.0g of anhydrous sodium sulphite in 100ml of demineralized water. It must be stored in a tightly closed bottle. Ideally, this bottle should have a sufficiently wide neck to allow direct insertion of the oxygen and temperature sensors. Do not store the solution for more than one week.

When the oxygen sensor is dipped into the solution, ensure that no air bubbles are trapped on, or close to, the membrane and that the sensor is supported so that the membrane cannot be damaged by contact with the bottom of the bottle.

When the sensors are withdrawn, all traces of sodium sulphite must be removed by rinsing them thoroughly with demineralized water.

#### A3.2 Span Calibration

Either air or air-saturated water may be used. Air calibration is more convenient and is likely, in practice, to be at least as accurate as calibration in air-saturated water.

##### A3.2.1 Air Calibration

The air must be saturated with water vapour. This is conveniently achieved by suspending the sensors inside a bottle containing a few drops of water. Alternatively, the sensors can be suspended close (within a few centimetres) to the surface of a body of water.

The operation of the oxygen sensor is such that the output in air is slightly higher than in air-saturated water at the same temperature. This difference is reproducible, allowing calibration in air by adjusting the instrument reading to 108% saturation (or the equivalent concentration) rather than 100%. This adjustment is made automatically in the calibration procedure.

##### A3.2.2 Air-saturated Water Calibration

The air-saturated water must be prepared, as described below, well in advance. Using an aeration stone, or a sintered glass diffuser, aerate approximately 1 litre (0.22 galls.) of demineralized water, either continuously for at least five minutes with a small pump, or intermittently for at least 15 minutes with hand bellows. These techniques are adequate for many applications provided the ambient temperature is constant. However, to obtain an accurate 100% saturation solution, the water must be maintained at constant temperature and stirred gently, without forced aeration, using a magnetic stirrer set to provide continuous agitation without breaking the liquid surface. This process must be continued for at least two hours to attain complete equilibrium. For calibration, the sensors must be suspended in the air-saturated water, which must be stirred continuously so that the flow velocity at the membrane of the oxygen sensor is at least 30cm/s (9.8 ft/s).

## APPENDIX B

### B1 Single PID Controller – Fig. B1

The single PID controller is a basic feedback control system using three-term PID control with a local set point.

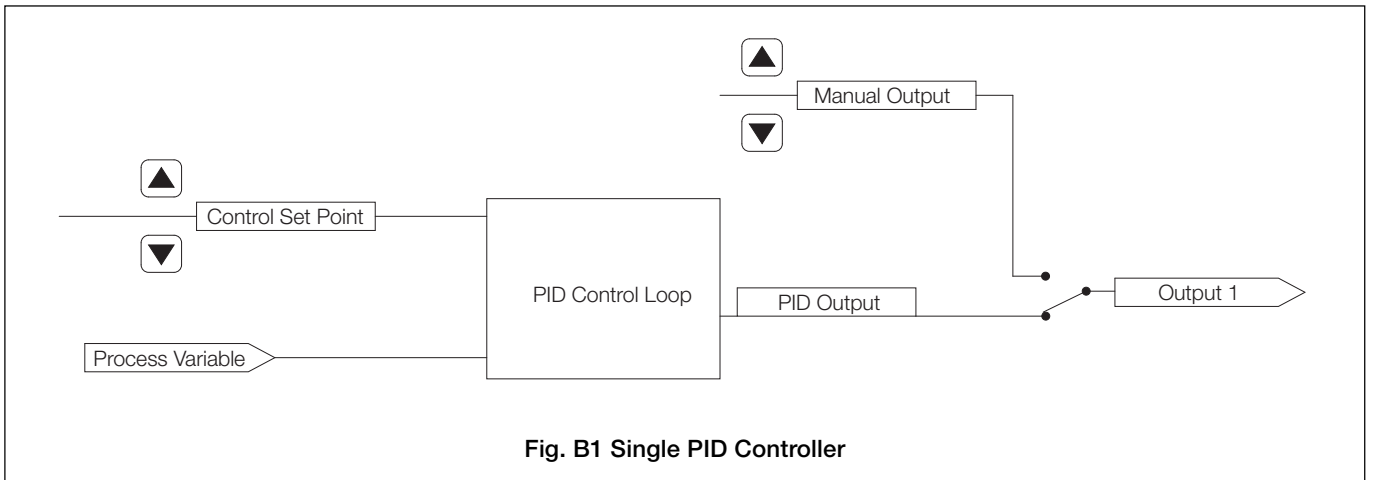

### B1.1 Reverse Acting Single PID Control – Fig. B2

Reverse acting control is used when the process DO is less than the required output DO.

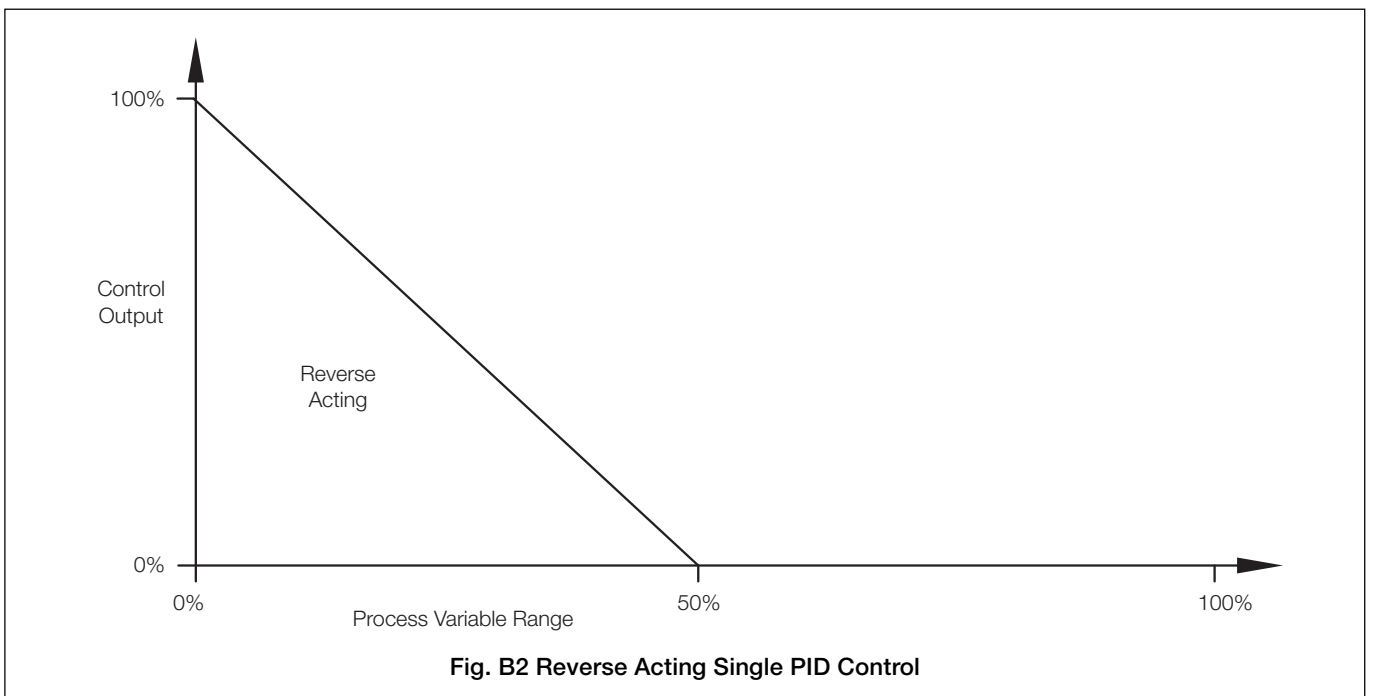

**B1.2 Direct Acting Single PID Control – Fig. B3**

Direct acting control is used when the process DO is greater than the required output DO.

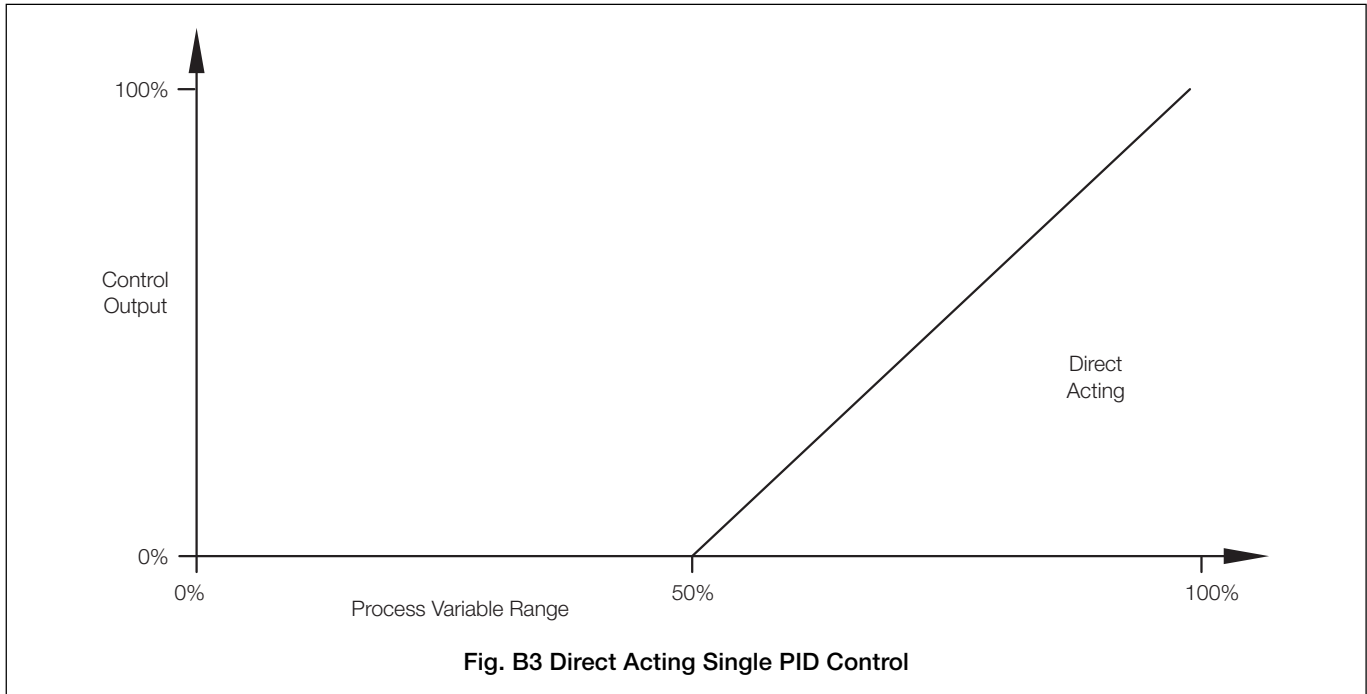

**B2 Output Assignment**

The output signal is assignable to either relay 1 (Time or Pulse output type) or analog output 1 (Analog output type).

### B3 Setting Up Three Term (PID) Control Parameters

To enable a process to be controlled satisfactorily, the following conditions must apply:

- a) The process must be capable of reaching a natural balance with a steady load.
- b) It must be possible to introduce small changes into the system without destroying either the process or the product.

The **Proportional Band** determines the gain of the system. (the gain is the reciprocal of the proportional band setting, e.g. a setting of 20% is equivalent to a gain of 5). If the proportional band is too narrow, the control loop may become unstable and cause the system to oscillate. With proportional band control only, the system normally stabilizes eventually but at a value which is offset from the set point.

The addition of **Integral Action Time** removes the offset but, if set too short, can cause the system to go into oscillation. The introduction of **Derivative Action Time** reduces the time required by the process to stabilize.

### B4 Manual Tuning

Before starting up a new process or changing an existing one:

- a) Select the **Config. Control** page and ensure that **Controller** is set to **PID** – see Section 5.7.
- b) Select the **PID Controller** page and set the following:

<b>Proportional Band</b>	- 100%	} – see Section 5.7.1
<b>Integral Time</b>	- 0 (off)	
<b>Derivative Time</b>	- 0 (off)	

**Notes.**

- If the system goes into oscillation with increasing amplitude (Fig. B4 Mode B), reset the proportional band to 200%. If oscillation continues as in Mode B, increase the proportional band further until the system ceases to oscillate.
- If the system oscillates as in Fig. B4 Mode A, or does not oscillate, refer to step c).

- c) Reduce the **Proportional Band** by 20% increments and observe the response. Continue until the process cycles continuously without reaching a stable condition (i.e. a sustained oscillation with constant amplitude as shown in Mode C). This is the critical point.
- d) Note the cycle time 't' (Fig. B4 Mode C) and the **Proportional Band** (critical value) setting.
- e) Set **Proportional Band** to:
  - 1.6 times the critical value (for P+D or P+I+D control)
  - 2.2 times the critical value (for P+I control)
  - 2.0 times the critical value (for P only control)

- f) Set **Integral Time** to:
  - $\frac{t}{2}$  (for P+I+D control)
  - $\frac{t}{1.2}$  (for P+D control)

- g) Set **Derivative Time** to:
  - $\frac{t}{8}$  (for P+I+D control)
  - $\frac{t}{12}$  (for P+D control)

The analyzer is now ready for fine tuning by small adjustments to the P, I and D terms, after the introduction of a small disturbance of the set point.

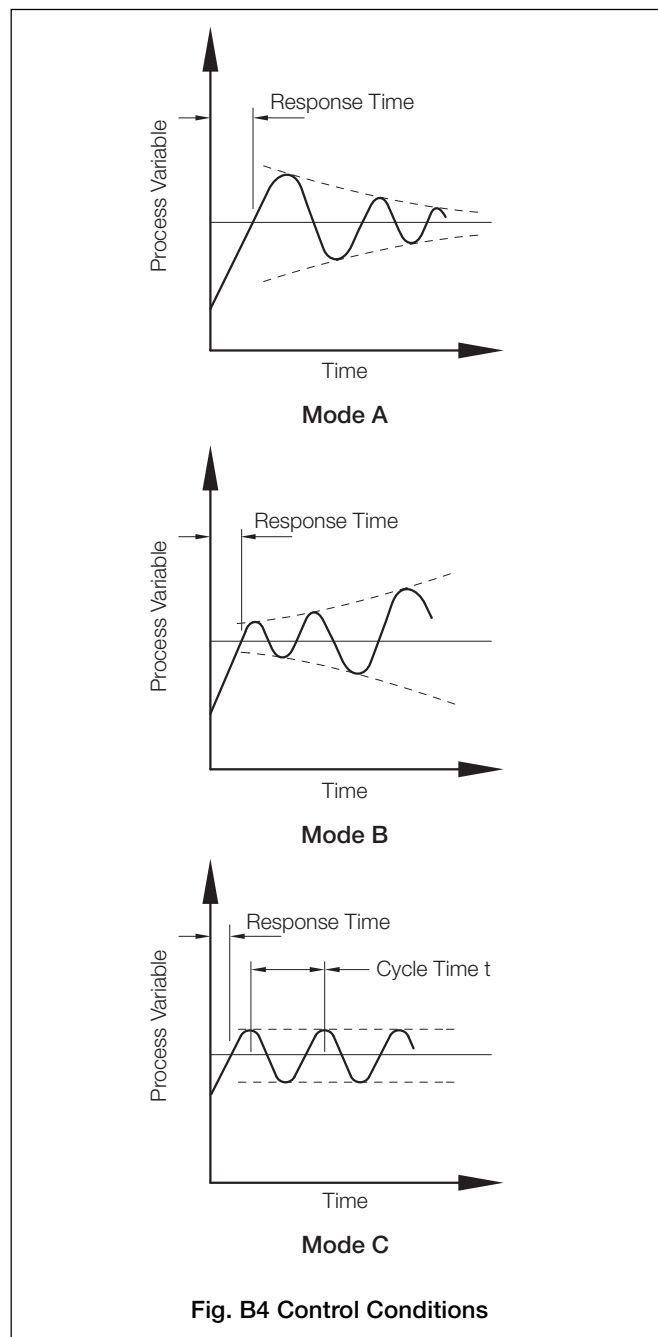

---

## NOTES

---

# Products and customer support

## Automation Systems

For the following industries:

- Chemical & Pharmaceutical
- Food & Beverage
- Manufacturing
- Metals and Minerals
- Oil, Gas & Petrochemical
- Pulp and Paper

## Drives and Motors

- AC and DC Drives, AC and DC Machines, AC Motors to 1kV
- Drive Systems
- Force Measurement
- Servo Drives

## Controllers & Recorders

- Single and Multi-loop Controllers
- Circular Chart and Strip Chart Recorders
- Paperless Recorders
- Process Indicators

## Flexible Automation

- Industrial Robots and Robot Systems

## Flow Measurement

- Electromagnetic Flowmeters
- Mass Flowmeters
- Turbine Flowmeters
- Wedge Flow Elements

## Marine Systems & Turbochargers

- Electrical Systems
- Marine Equipment
- Offshore Retrofit and Refurbishment

## Process Analytics

- Process Gas Analysis
- Systems Integration

## Transmitters

- Pressure
- Temperature
- Level
- Interface Modules

## Valves, Actuators and Positioners

- Control Valves
- Actuators
- Positioners

## Water, Gas & Industrial Analytics Instrumentation

- pH, Conductivity and Dissolved Oxygen Transmitters and Sensors
- Ammonia, Nitrate, Phosphate, Silica, Sodium, Chloride, Fluoride, Dissolved Oxygen and Hydrazine Analyzers
- Zirconia Oxygen Analyzers, Katharometers, Hydrogen Purity and Purge-gas Monitors, Thermal Conductivity

## Customer support

We provide a comprehensive after sales service via a Worldwide Service Organization. Contact one of the following offices for details on your nearest Service and Repair Centre.

### UK

ABB Limited  
Tel: +44 (0)1453 826661  
Fax: +44 (0)1453 829671

### USA

ABB Inc.  
Tel: +1 215 674 6000  
Fax: +1 215 674 7183

### Client Warranty

Prior to installation, the equipment referred to in this manual must be stored in a clean, dry environment, in accordance with the Company's published specification. Periodic checks must be made on the equipment's condition. In the event of a failure under warranty, the following documentation must be provided as substantiation:

- A listing evidencing process operation and alarm logs at time of failure.
- Copies of all storage, installation, operating and maintenance records relating to the alleged faulty unit.

# Contact us

## **ABB Limited**

### **Process Automation**

Oldends Lane  
Stonehouse  
Gloucestershire GL10 3TA  
UK

Tel: +44 1453 826 661

Fax: +44 1453 829 671

## **ABB Inc.**

### **Process Automation**

125 E. County Line Road  
Warminster  
PA 18974  
USA

Tel: +1 215 674 6000

Fax: +1 215 674 7183

[www.abb.com](http://www.abb.com)

#### Note

We reserve the right to make technical changes or modify the contents of this document without prior notice. With regard to purchase orders, the agreed particulars shall prevail. ABB does not accept any responsibility whatsoever for potential errors or possible lack of information in this document.

We reserve all rights in this document and in the subject matter and illustrations contained therein. Any reproduction, disclosure to third parties or utilization of its contents in whole or in parts – is forbidden without prior written consent of ABB.

Copyright© 2011 ABB

All rights reserved