











Electrical Safety

This equipment complies with the requirements of CEI/IEC 61010-1:2001-2 "Safety Requirements for Electrical Equipment for Measurement, Control and Laboratory Use". If the equipment is used in a manner NOT specified by the Company, the protection provided by the equipment may be impaired.

Symbols

One or more of the following symbols may appear on the instrument labelling:

	Warning – Refer to the manual for instructions		Direct current supply only
	Caution – Risk of electric shock		Alternating current supply only
	Protective earth (ground) terminal		Both direct and alternating current supply
	Earth (ground) terminal		The equipment is protected through double insulation

Information in this manual is intended only to assist our customers in the efficient operation of our equipment. Use of this manual for any other purpose is specifically prohibited and its contents are not to be reproduced in full or part without prior approval of the Technical Publications Department.

Health and Safety

To ensure that our products are safe and without risk to health, the following points must be noted:

1. The relevant sections of these instructions must be read carefully before proceeding.
2. Warning labels on containers and packages must be observed.
3. Installation, operation, maintenance and servicing must only be carried out by suitably trained personnel and in accordance with the information given.
4. Normal safety precautions must be taken to avoid the possibility of an accident occurring when operating in conditions of high pressure and/or temperature.
5. Chemicals must be stored away from heat, protected from temperature extremes and powders kept dry. Normal safe handling procedures must be used.
6. When disposing of chemicals ensure that no two chemicals are mixed.

Safety advice concerning the use of the equipment described in this manual or any relevant hazard data sheets (where applicable) may be obtained from the Company address on the back cover, together with servicing and spares information.

GETTING STARTED

This manual is divided into 5 sections which contain all the information needed to install, configure, commission and operate the COMMANDER V100. Each section is identified clearly by a symbol as shown below.



Displays and Function Keys

- Displays and function keys
- LED Indication
- Error Messages



Operator Mode (Level 1)

- Operator menus for:
 - *Standard controller*
 - *Remote Set Point controller*
 - *Profile controller*
 - *Multiple Fixed Set Points controller*



Set Up Mode (Levels 2, 3 and 4)

- Level 2 – Tuning
- Level 3 – Set Points
- Level 4 – Profile



Configuration Mode (Levels 5 and 6)

- Level 5 – Basic hardware and control functions
- Level 6 – Ranges and passwords



Installation

- Siting
- Mounting
- Electrical connections

Symbol Identification and Section Contents

CONTENTS

1	DISPLAYS AND FUNCTION KEYS	3
1.1	Introduction	3
1.2	Use of Function Keys	4
1.3	LED Alarms and Indicators	5
1.4	Error Messages	6
2	OPERATOR MODE	7
2.1	Introduction	7
2.2	Standard Controller	8
2.3	Remote Set Point Controller	10
2.4	Profile Controller	12
2.5	Multiple Fixed Set Points Controller	14
3	SET UP MODE	16
3.1	Introduction	16
3.2	Motorized Valve Control	17
3.3	Tuning (Level 2)	19
3.4	Set Points (Level 3)	20
3.5	Profile (Level 4)	23
4	CONFIGURATION MODE	26
4.1	Introduction	26
4.2	Accessing the Configuration Mode	26
4.3	Basic Hardware and Configuration (Level 5)	28
4.4	Ranges and Passwords (Level 6)	38
5	INSTALLATION	41
5.1	Siting	41
5.2	Mounting	43
5.3	Electrical Connections	45
5.4	Relays, Arc Suppression, Inputs and Outputs	45

Information.

The fold-out page inside on the back cover of this manual shows all the frames in the programming levels. Space is provided on the page for writing the programmed setting or selection for each frame.

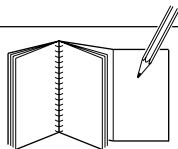

1 DISPLAYS AND FUNCTION KEYS

1.1 Introduction – Fig. 1.1

The COMMANDER V100 front panel displays, function keys and LED indicators are shown in Fig. 1.1.

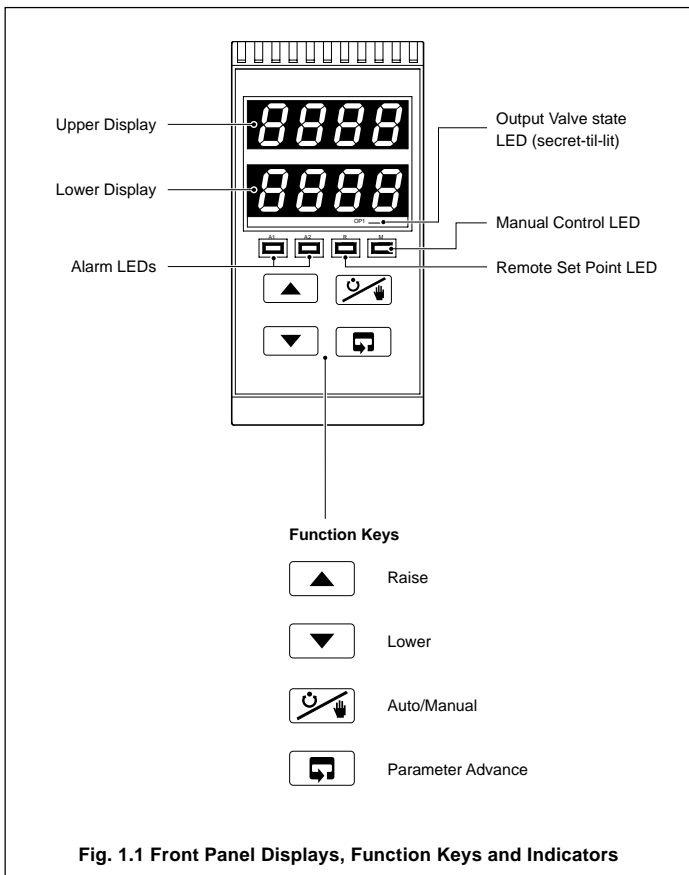
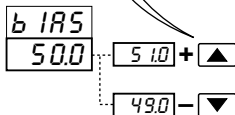

Fig. 1.1 Front Panel Displays, Function Keys and Indicators

1.2 Use of Function Keys – Fig. 1.2

A – Raise and Lower Keys



Use to change/set a parameter value... and...

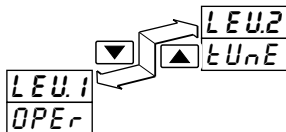

...move between levels

B – Parameter Advance Key

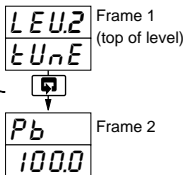

Use to advance to the next frame within a level...

and...

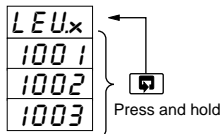

...select the top (LEUEL) frame from within a level

Note. This key also stores any changes made in the previous frame

C – Auto/Manual Key

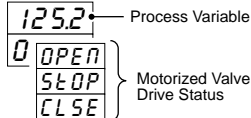
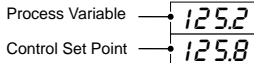
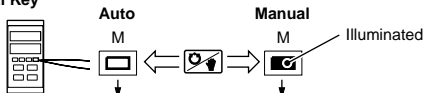

Use to select Auto or Manual control mode

Fig. 1.2 Use of Function Keys



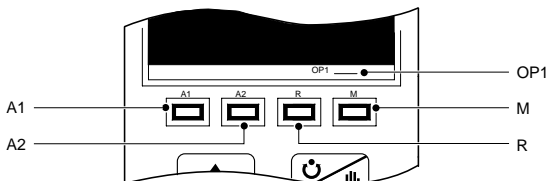





1.3 LED Alarms and Indicators

**LED Status**

- All** • All LED's flashing – controller is in the configuration mode.
- A1** • Flashes when Alarm 1 is active (off when inactive).
- A2** • Flashes when Alarm 2 is active (off when inactive).
- R**
- On when the controller is operating on the remote set point value.
 - Off when the controller is operating using the local set point value or one of the four fixed set points (in multiple set point mode).
 - Flashes when a Ramp/Soak profile is running.
- M**
- On when the controller is operating in Manual control mode.
 - Off when the controller is operating in Auto control mode.
- OPI** • Secret-til-lit LED indicates when the output valve state is displayed in the lower display.

Fig. 1.3 LED Alarms and Indicators

1.4 Error Messages

Display	Error/Action	To Clear Display
	Calibration error Turn mains power off and on again (if the error persists contact the Service Organization).	Press the  key
	Configuration error The configuration and/or setup data for the instrument is corrupted. Turn mains power off and on again (if the error persists, check configuration/setup settings).	Press the  key
	A to D Converter Fault The analog to digital converter is not communicating correctly.	Turn the power off and on again, if the error persists contact the service organization.
	Process Variable Over/Under Range	Restore valid input
	Remote Set Point Over/Under Range The remote set point value is over or under range. Flashing stops automatically when the remote set point input comes back into range.	Select the local set point (rSP.n) in the Operating Page or the Set Points Level
	Option error Communications to the option board have failed.	Contact the Service Organization



2 OPERATOR MODE

2.1 Introduction

Operator Mode (Level 1) is the normal day-to-day mode of the COMMANDER 100. Frames displayed in level 1 are determined by the control strategy which is selected during configuration of the instrument – see Section 4.

Note. Only the operating frames relevant to the configured strategy are displayed in Operator Mode.

The four control strategies are:

- **Standard controller** – page 8
- **Remote Set Point controller** – page 10
- **Profile controller** – page 12
- **Multiple Fixed Set Points controller** – page 14



2.2 Standard Controller

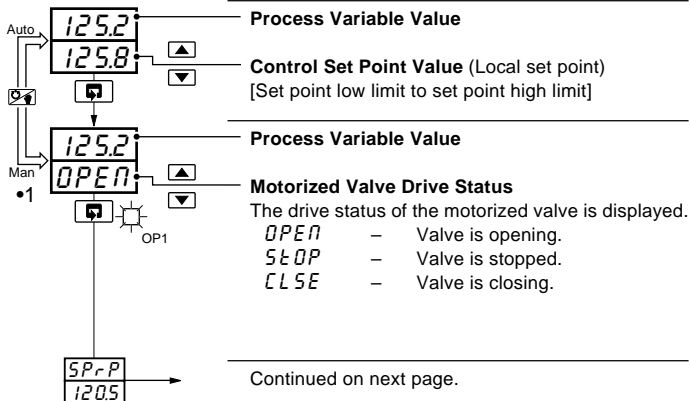

- 1 The Valve Drive Status is adjustable in Manual mode only.



...2.2 Standard Controller

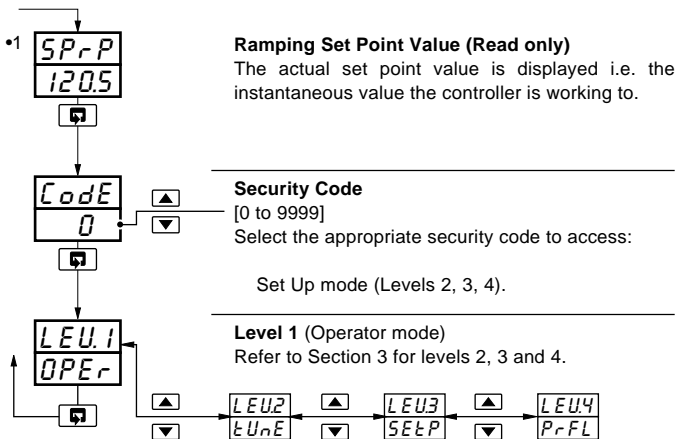

Ramping Set Point Value (Read only)

The actual set point value is displayed i.e. the instantaneous value the controller is working to.

Security Code

[0 to 9999]

Select the appropriate security code to access:

Set Up mode (Levels 2, 3, 4).

Level 1 (Operator mode)

Refer to Section 3 for levels 2, 3 and 4.

- 1 Not displayed if the ramping set point facility is turned off – refer to Section 3.4.

2.3 Remote Set Point Controller

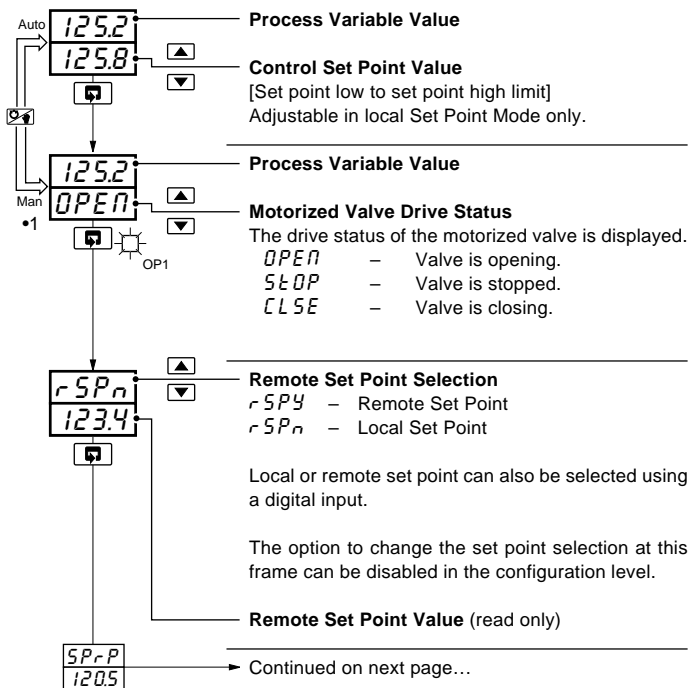

Note.

If the remote set point input fails while selected, the controller selects the local set point value automatically. The upper display changes to *rSP.F* and the lower display flashes. When the fault condition is removed the remote set point is re-selected automatically. To clear the error condition while the remote set point input is still outside its allowed range, select the local set point by pressing the ∇ key (*rSP.n* is displayed).

*1 The Valve Drive Status is adjustable in Manual mode only.



...2.3 Remote Set Point Controller

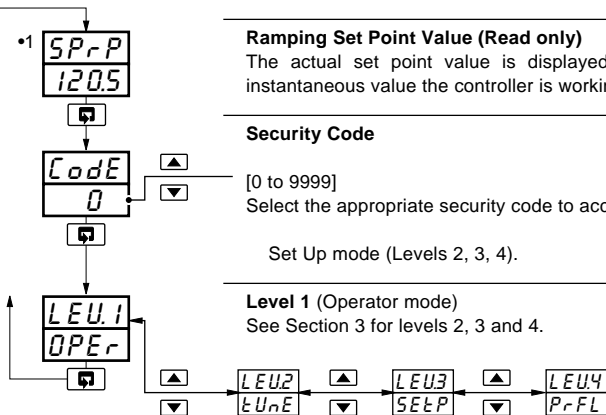

- 1 Not displayed if the ramping set point facility is turned off – refer to Section 3.4.



2.4 Profile Controller

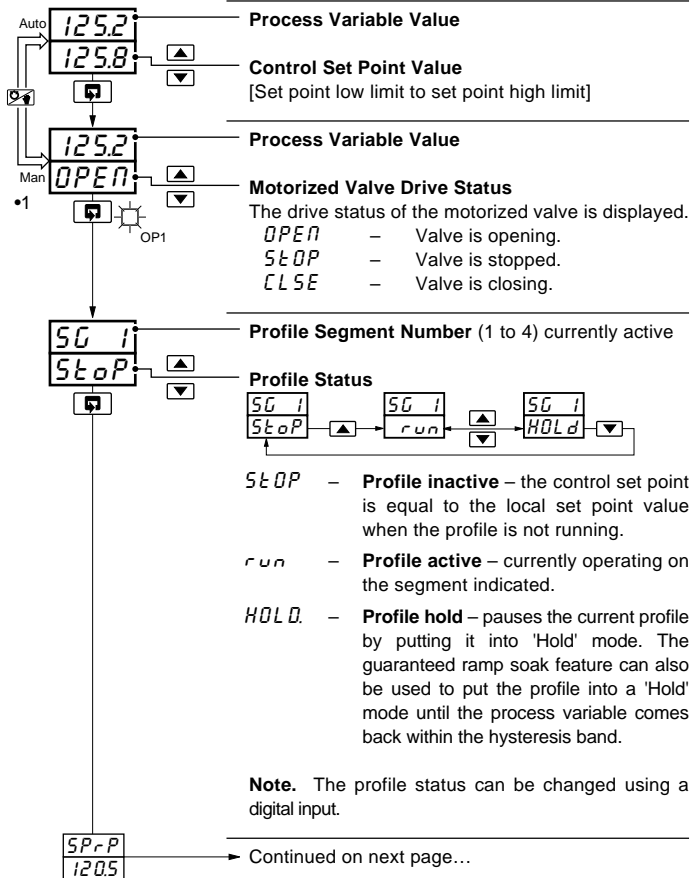

•1 The Valve Drive Status is adjustable in Manual mode only.



...2.4 Profile Controller

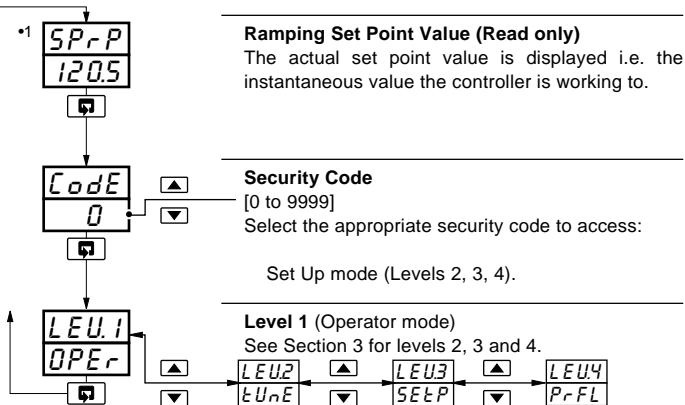

- 1 Not displayed if the ramping set point facility is turned off – refer to Section 3.4.



2.5 Multiple Fixed Set Points Controller

If the Multiple Fixed Set Points Controller type is selected during configuration, four fixed control set points can be set – see Section 4.4.

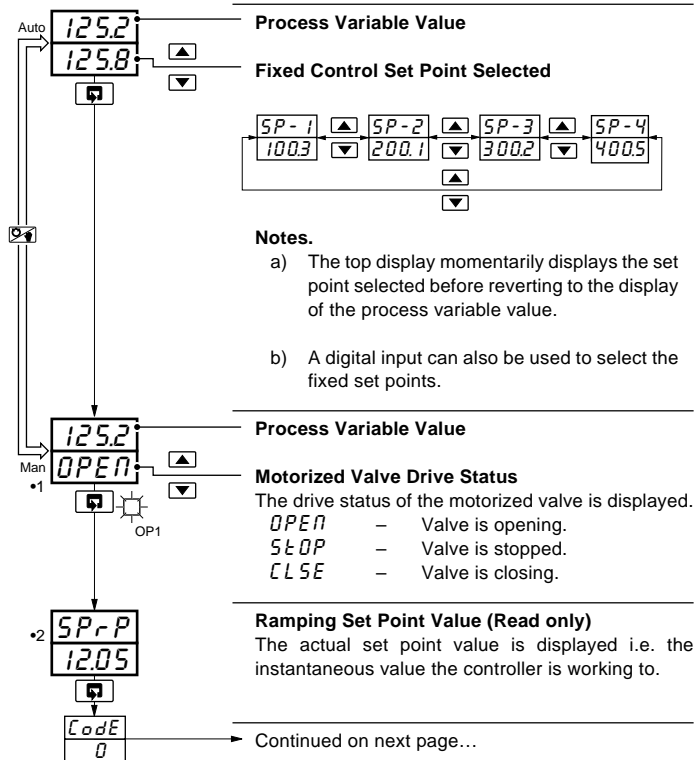

- 1 The Valve Drive Status is adjustable in Manual mode only
- 2 Not displayed if the ramping set point facility is turned off – refer to Section 3.4.



...2.5 Multiple Fixed Set Points Controller

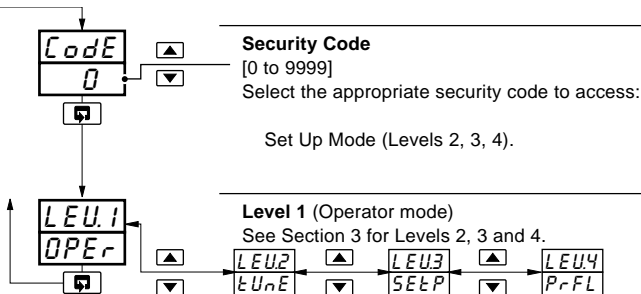

3.1 Introduction

To access the Set Up Mode (Levels 2, 3 and 4) the correct password must be entered in the security code frame (the default password code is 0). Refer to the fold-out sheet at the back of this manual for the contents of these levels.

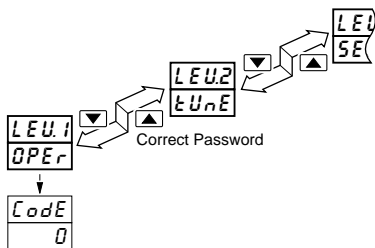

Refer to the fold-out sheet
for the contents of each level

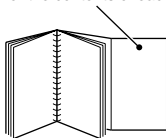



3.2 Motorized Valve Control – Fig. 3.1

The V100 is a 'boundless' process controller which provides an output that is effectively the time derivative of the required regulator position, i.e. the controller signals the regulator, not where to go to (position derivative), but in which direction to travel and how far to move, by a series of integral action pulses. Thus, the controller does not need to know the absolute regulator position and is unaffected when regulator reaches the upper or lower limit, as determined by the regulator's limit switches (giving rise to the term 'boundless').

When a deviation from set point is introduced the regulator is driven, for a length of time equivalent to the proportional step. The regulator is then driven by integral action pulses until the deviation is within the deadband setting.

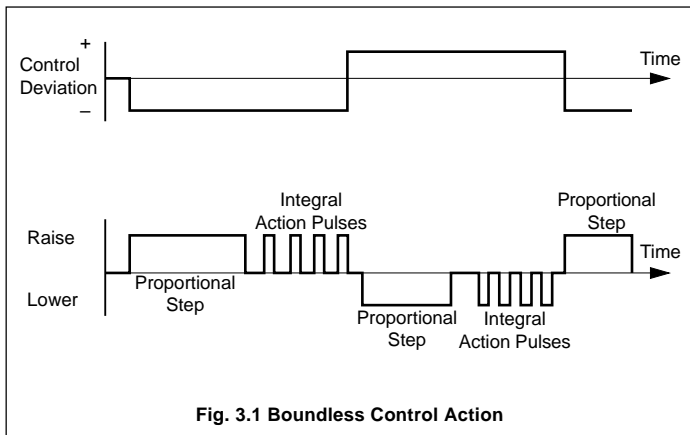



3.2.1 Calculation for Control Pulses, Steps and Deviation (Boundless Control only)

The following calculations, carried out by the instrument, are shown for guidance when setting deadband/travel time values. They can be used to check the suitability of boundless control for a particular application.

Minimum 'ON' time of integral action pulses (for a fixed control deviation).

$$= \frac{\text{Travel Time} \times \text{Deadband \%}}{\% \text{ Proportional Band}} \quad (\text{in seconds})$$

Minimum (approximate) time between integral action pulses (for a fixed control deviation)

$$= \frac{\text{Integral Action Time} \times \text{Deadband \%}}{2 \times \% \text{ Control Deviation}} \quad (\text{in seconds})$$

Duration of the proportional step

$$= 2 \times \left[\frac{\% \text{ Control Deviation}}{\% \text{ Proportional Band}} \right] \times \text{Travel Time in Seconds}$$

$$\% \text{ Control Deviation} = \frac{\text{Set Point} - \text{Process Variable}}{\text{Eng Hi} - \text{Eng Lo}} \times 100$$

$$\% \text{ Deadband} = \frac{\text{Deadband}}{\text{Eng Hi} - \text{Eng Lo}} \times 100$$



3.3 Tuning (Level 2)

LEU.2
tUNE



Pb
100.0



Intr
30



dr IU
1.0



dbnd
0.0



r.tr U
1000



Level 2 – Tuning Level

Note. To select this frame from anywhere in this page, press the key for a few seconds.

Proportional Band

Enter the proportional band value.
[0.1% to 999.9%]

Integral Action Time

[1 to 7200 seconds or OFF (OFF=0)]

Derivative Action Time

[0.1 to 999.9 seconds or OFF (OFF=0)].

Motorized Valve Deadband

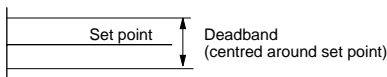

1 to 9999 [in engineering units].

Regulator Travel Time

Time taken for the regulator to travel from the fully open to the fully closed position.

[10 to 5000 seconds.]

3.4 Set Points (Level 3)

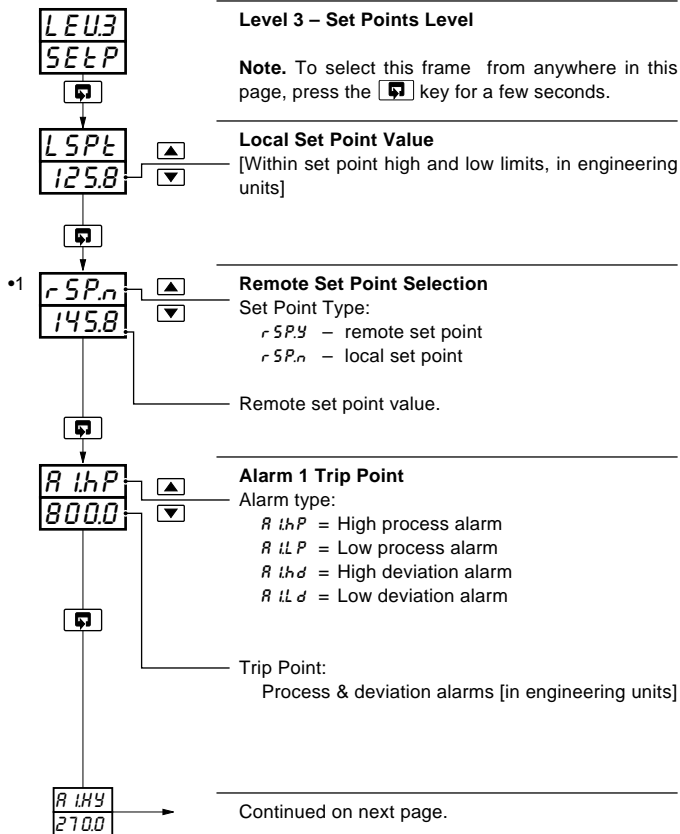



...3.4 Set Points (Level 3)

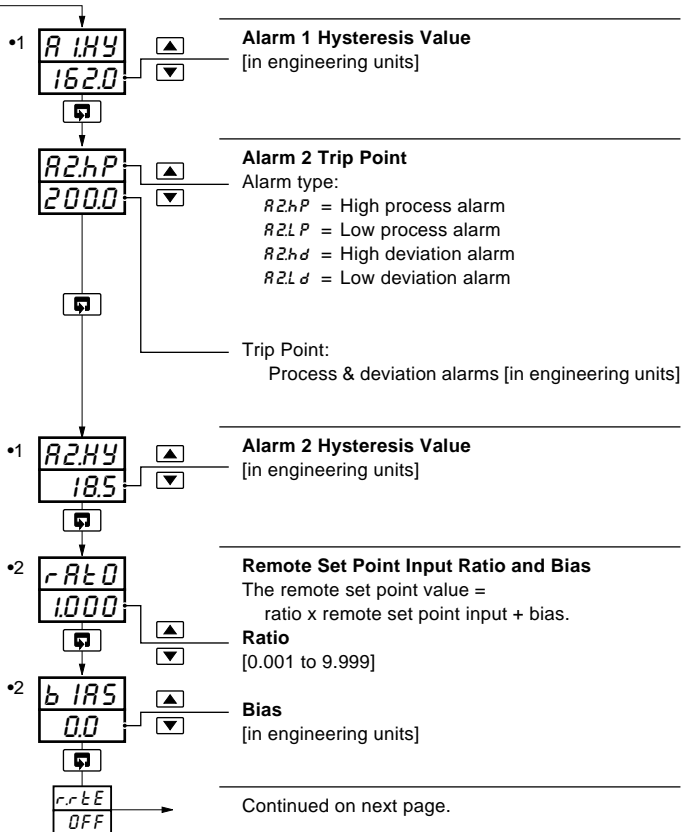

- 1 Only displayed if custom alarm hysteresis is selected – see section 4.3.2,
- 2 Only displayed if the remote set point option is selected.

...3.4 Set Points Level

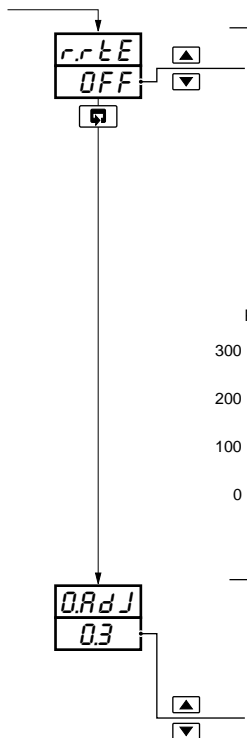
**Ramp Rate (for ramping set point facility)**

[1 to 9999 engineering units per hour, or OFF]

The ramping set point facility can be used to prevent a large disturbance to the control output when the set point value is changed. This only applies to the local and multiple fixed set points.

Note. For remote set points, the ramp rate is applicable only when switching from remote to local, not from local to remote.

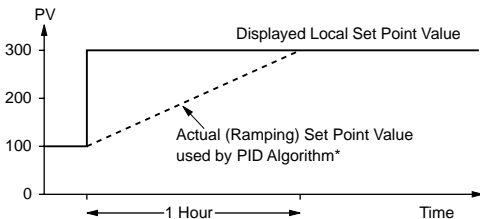

* e.g. Ramp Rate = 200 Increments/Hour

Offset Adjustment

An offset can be applied to the process variable input to enable spot calibration or the removal of system errors.

[±10% of engineering range in engineering units]



3.5 Profile (Level 4)

A four segment ramp/soak profile facility is provided. This level can only be accessed if the profile option is selected in the configuration level. The four segments are fixed as ramps or soaks as follows:

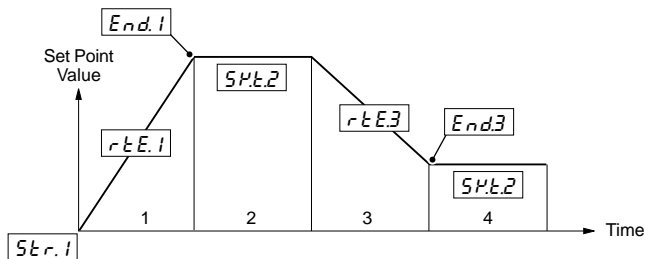

LEU.4
P-FL



*1

Str.1
100.0



End.1
200.0



rLE.1
10.0

Level 4 – Profile Level

Note. To select to this frame from anywhere in this page, press the key for a few seconds.

Start value for 1st Segment (ramp).

[Within display range (in engineering units)]

Enter the start value required.

End Value for 1st Segment (ramp).

[Within display range (in engineering units)]

Enter the end value required.

Continued on next page.

- *1 With the self-seeking set point facility enabled, the first ramp starts at the current process variable value instead of the start value for the 1st segment.

...3.5 Profile (Level 4)

•1
r t E.1
40.00

Ramp Rate for 1st Segment.

[Engineering units*]

Enter the ramp rate required.

* The time option Eng Units/hr or Eng Units/min is set in the configuration level – see section 4.3.2.

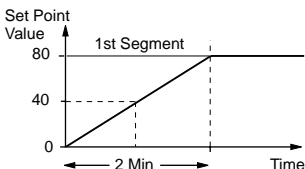

Example. Required Ramp Rate 40°C/min

Ramp Rate set to 40, Time Option set to 'Min' – see section 4.3.2

SPL.2
60.00

Soak Time for 2nd Segment.

[0 to 999.9 minutes or hours]*

End.3
100.0

End Value for 3rd Segment (ramp).

[Within display range (in engineering units)]

r t E.3
20.00

Ramp Rate for 3rd Segment.

[Engineering units/hour or /minute]*

* Depending on the time option selected in the configuration level.

SPL.4
30.00

Continued on next page.

•1 The engineering value is shown with an extra decimal place (up to a maximum of 3) for greater accuracy in setting the ramp rate.



...3.5 Profile (Level 4)

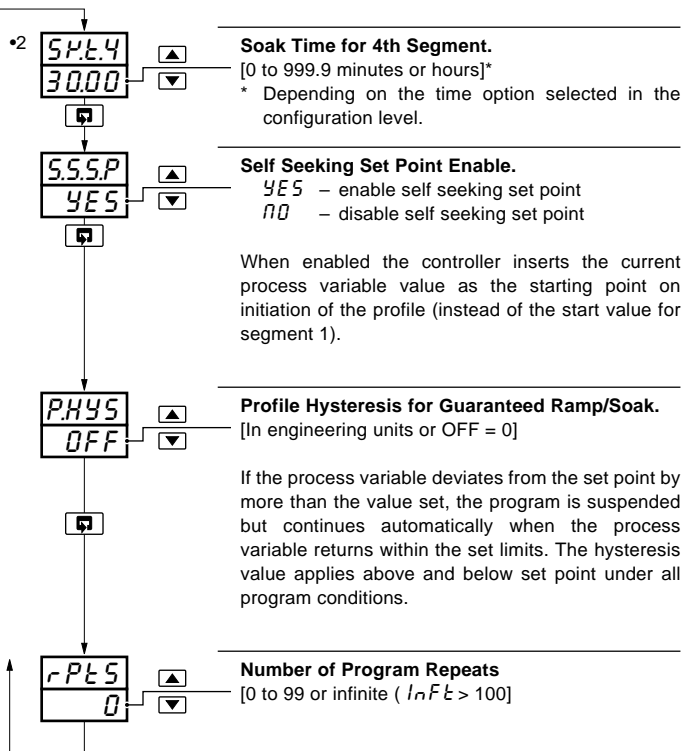

- 2 The engineering value is shown with an extra decimal place (up to a maximum of 3) for greater accuracy in setting the ramp rate.



4 CONFIGURATION MODE

4.1 Introduction

The Configuration Mode comprises two levels (5 and 6) as shown in Fig. 4.2.

Level 5 is divided into four frames. For most simple applications it is only necessary to set up the parameters in the first frame.

Note.

When in the configuration level:

- All the l.e.d. indicators flash.
- All relays and logic outputs are turned off.
- The analog output reverts to 0% (4mA) output level.

4.2 Accessing the Configuration Mode – Fig. 4.1

To access the Configuration Mode set the security switch to the 'Configure' position (levels 1 to 4 cannot be accessed from this setting). When the configuration parameters are programmed, reset the security switch to the 'Normal' position and the Operating page is displayed automatically .

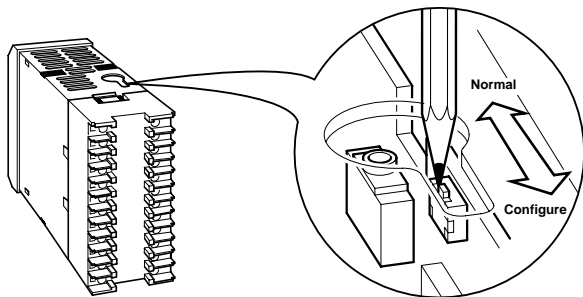

Fig. 4.1 Accessing the Configuration Mode (Config/Normal Switch)

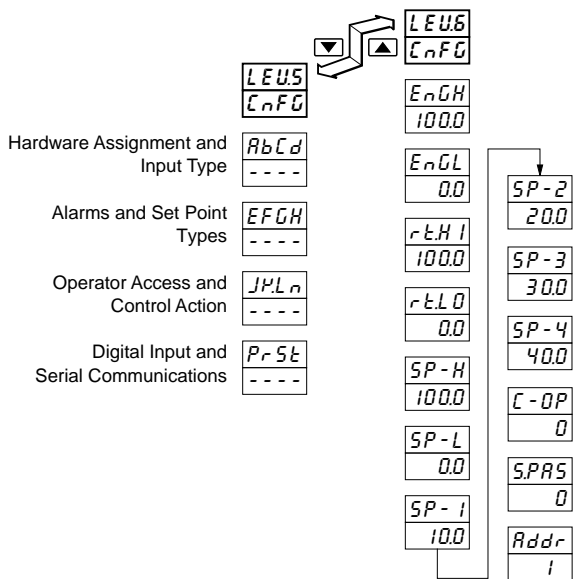

Fig. 4.2 Configuration Frames (Levels 5 and 6)



4.3 Basic Hardware and Configuration (Level 5)

4.3.1 Hardware Assignment and Input Type – Fig. 4.3



Level 5 –Configuration

Note. To select this frame from anywhere in this page, press the  key for a few seconds.

'ABCD' Settings

The parameter to be changed is indicated by the letter which is flashing. Parameter options are shown in Fig. 4.3.

- A* = Hardware configuration
- b* = Input type and range
- c* = Temperature units
- d* = Process variable display decimal places

Notes.

Note 1. When the input type (parameter *b*) is changed, the range is set automatically to the maximum permissible for the input type selected.

Note 2. For custom settings contact the local distributor.

Continued on page 30.



AbCd
6400

A – Hardware Configuration

Frequency	Rly 1	Rly 2	Rly 3*	Logic O/P	An. O/P 1	Control Type
50 Hz	Open valve	Close valve	Alarm 1	Alarm 2	PV Rtx	Boundless
60 Hz						
δ	Custom	Custom	Custom	Custom	Custom	Custom
F						
U	Custom	Custom	Custom	Custom	Custom	Custom

* Only available if option boards 2 or 3 are fitted

AbCd
6400

B – Input Type and Range Configuration

Display		Display	
b	THC Type B	i	0 to 20 mA
E	THC Type E	2	4 to 20 mA
J	THC Type J	3	0 to 5 V
K	THC Type K	4	1 to 5 V
n	THC Type N	δ	0 to 50 mV
r	THC Type R	7	4 to 20 mA (square root lineariser)
S	THC Type S	U	Custom Configuration
t	THC Type T		
P	PT100 RTD		

AbCd
6400

C – Temperature Units

Display	Temperature Units
C	Degrees C*
F	Degrees F*
0	No temperature units

* Temperature inputs only

AbCd
6400

D – Process Variable Display
Decimal Places

Display	
0	xxxx
1	xxx . x
2	xx . xx
3	x . xxx

Fig. 4.3 Hardware Assignment and Input Type



4.3.2 Alarms and Set Point Types – Fig. 4.4

Note. All relays are **de-energised** in the alarm state.

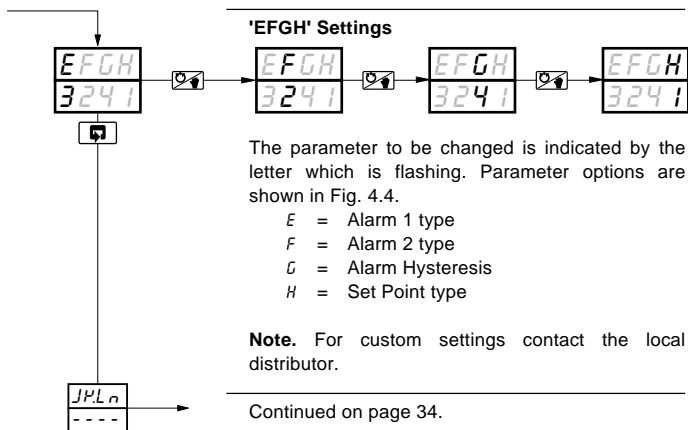



EFGH
3241

E – Alarm 1 Type*

Display	
0	None
1	High Process
2	Low Process
3	High Deviation
4	Low Deviation

EFGH
3241

F – Alarm 2 Type*

Display	
0	None
1	High Process
2	Low Process
3	High Deviation
4	Low Deviation

* Refer to Figs. 4.5 and 4.6 for alarm action

EFGH
3241

G – Alarm Hysteresis

Display	
0	None
1	0.1%
2	0.2%
3	0.5%
4	1.0%
5	2.0%
6	5.0%
U	Custom

} Value in % of
engineering
range

} Value in engineering units – see Note 1

Note 1. When custom alarm hysteresis is selected, the alarm hysteresis values are set individually in the **set up level** – see section 3.3

EFGH
3241

H – Set Point Type

Display	
0	Local Set Point Only
1	Local + Remote Set Point (no Remote Set Point Tracking)**
2	Local + Remote Set Point (with Remote Set Point Tracking)**
3	Multiple Fixed Set Points
4	Ramp/Soak (Time Units in Minutes)
5	Ramp/Soak (Time Units in Hours)

} See Note 2

**Only available if option board is fitted. Remote set point input is 4 to 20 mA

Note 2. With remote set point tracking enabled the local set point tracks the remote set point when in the remote set point mode.

Fig. 4.4 Alarms and Set Point Types



...4.3.2 Alarms and Set Point Types – Fig. 4.4

Note. All relays are **de-energised** in the alarm state.

Process and Deviation Alarms (High/Low) – Figs 4.5 and 4.6

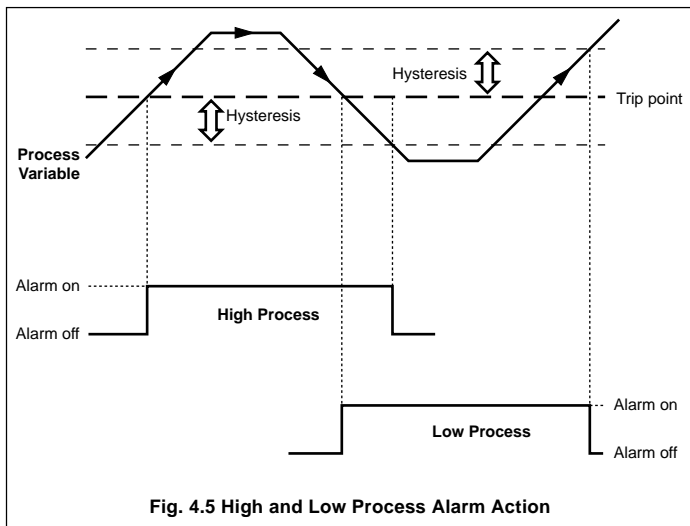

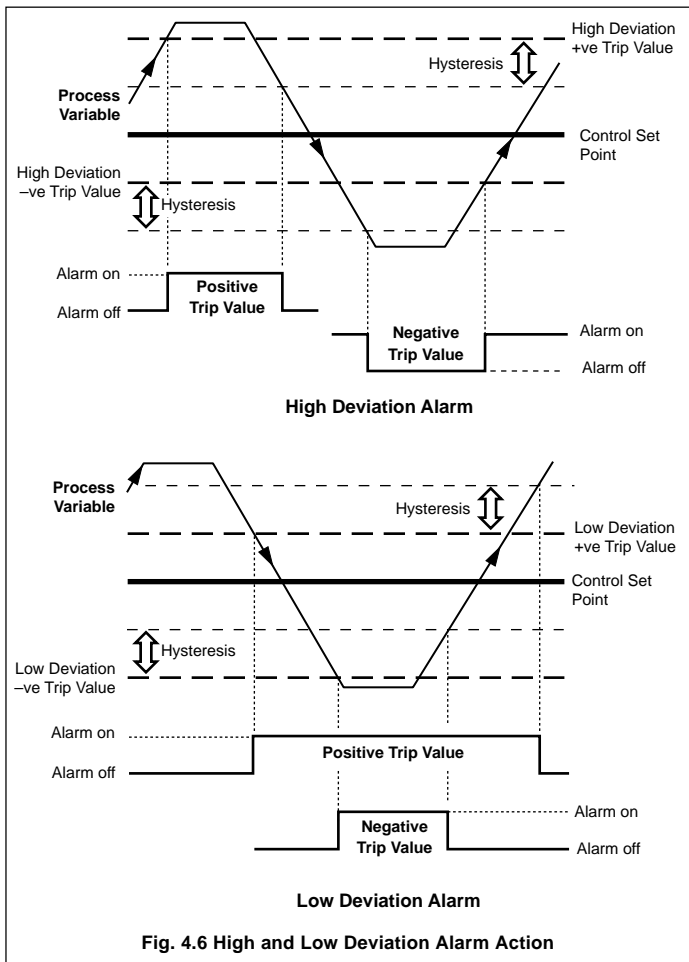



4.3.3 Operator Access and Control Action – Fig. 4.7

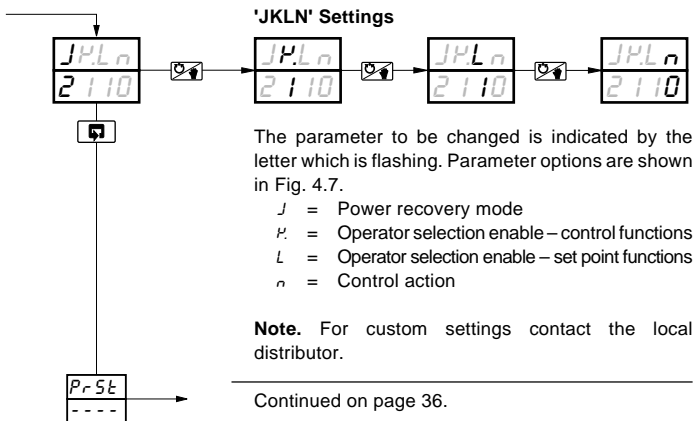

Continued on page 36.



JPLn
2110

J – Power Recovery Mode

Display	Mode
0	Last Mode
1	Manual with last Valve position
2	Manual with Valve fully closed
3	Manual with Valve fully open
4	Auto
U	Custom

JPLn
2110

K – Operator Selection Enable Control Functions

Display	Auto/Manual
0	Enable Auto/Manual
1	Disable Auto/Manual

JPLn
2110

L – Operator Selection Enable – Set Point Functions

Display	Local Set Point Adjustment and Local/Remote Set Point Selection
0	Enable Both Functions
1	Disable Set Point Adjust, Enable Local/Remote Selection
2	Enable Set Point Adjust, Disable Local Remote Function
3	Disable Both Functions

JPLn
2110

N – Control Action

Display	Action
0	Reverse
1	Direct

Fig. 4.7 Operator Access and Control Action



4.3.4 Digital Input and Serial Communications – Fig. 4.8

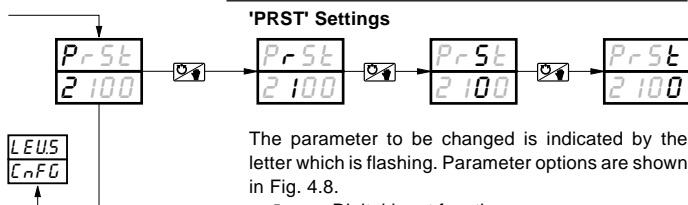

The parameter to be changed is indicated by the letter which is flashing. Parameter options are shown in Fig. 4.8.

- P* = Digital input function
- r* = Analog input digital filter
- S* = Serial communications configuration
- t* = Serial communication parity

Note. For custom settings contact the local distributor.

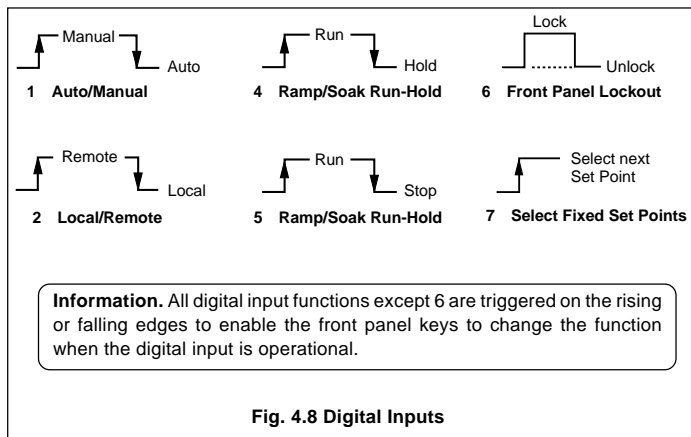

Fig. 4.8 Digital Inputs

P – Digital Input Functions

PrSt
2 100

Display	Function
0	None
1	Auto/Manual
2	Local/Remote
4	Ramp/Soak Run-Hold
5	Ramp/Soak Run-Stop
6	Front Panel Lockout
7	Select Fixed Set Points

R – Analog Input Digital Filter

PrSt
2 100

Display	
0	0 seconds
1	1 second
2	2 seconds
5	5 seconds
A	10 seconds
B	20 seconds
C	40 seconds
D	60 seconds

Input filter averages the process variable input values over the time set

S – Serial Communication Configuration

PrSt
2 100

Display	Baud Rate, 2/4 Wire
0	Off
1	2400, 2 Wire
2	2400, 4 Wire
3	9600, 2 Wire
4	9600, 4 Wire

T – Serial Communications Parity

PrSt
2 100

Display	
0	None
1	Odd
2	Even

Fig. 4.9 Digital Input and Serial Communications



4.4 Ranges and Passwords (Level 6)

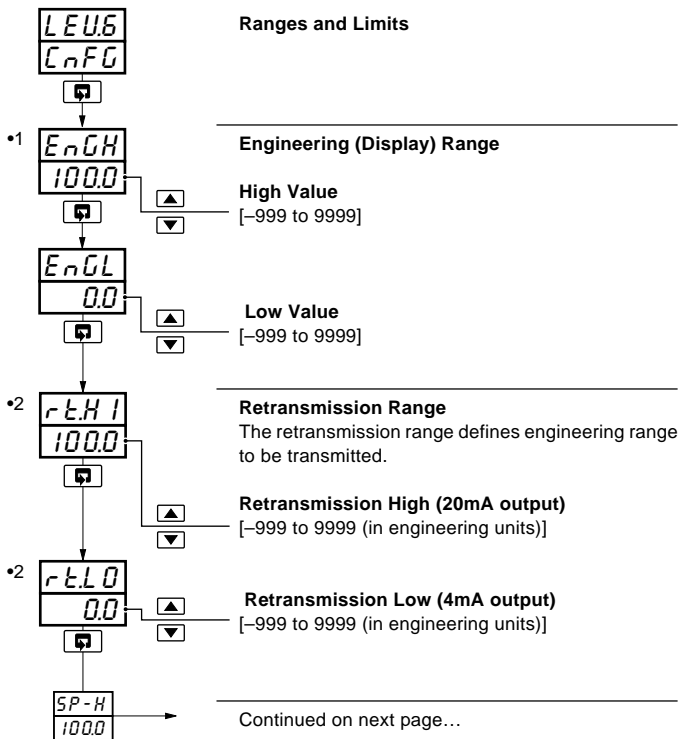

•1 The engineering range high and low values are automatically set to the maximum allowed value when thermocouple or RTD is selected in the configuration level – see Section 4.3.1.

•2 Only displayed if the analog output is configured to retransmit the process variable or control set point value.



...4.4 Ranges and Passwords (Level 6)

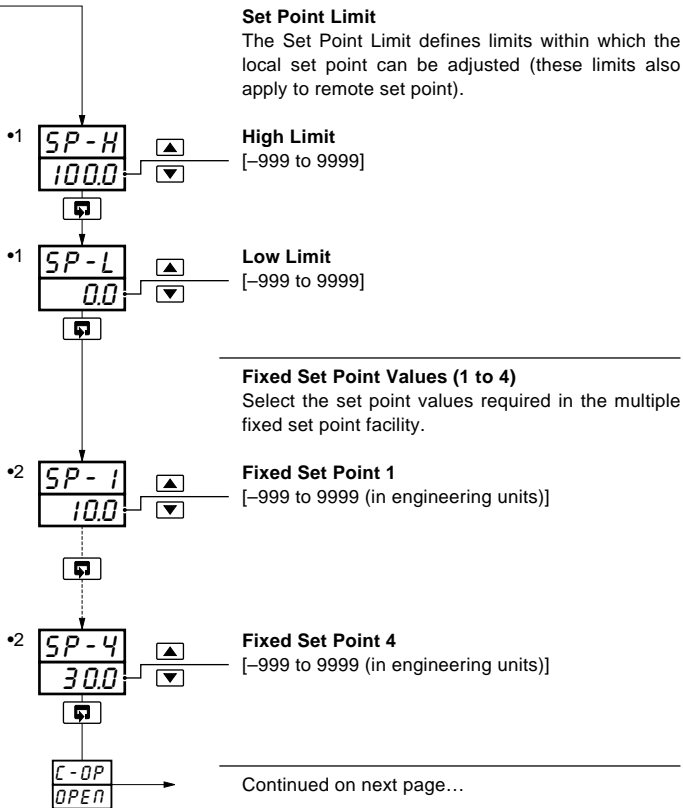

- 1 This limit applies to the local and remote set point values.
- 2 Only displayed if the multiple fixed set point facility is selected.



...4.4 Ranges and Passwords (Level 6)

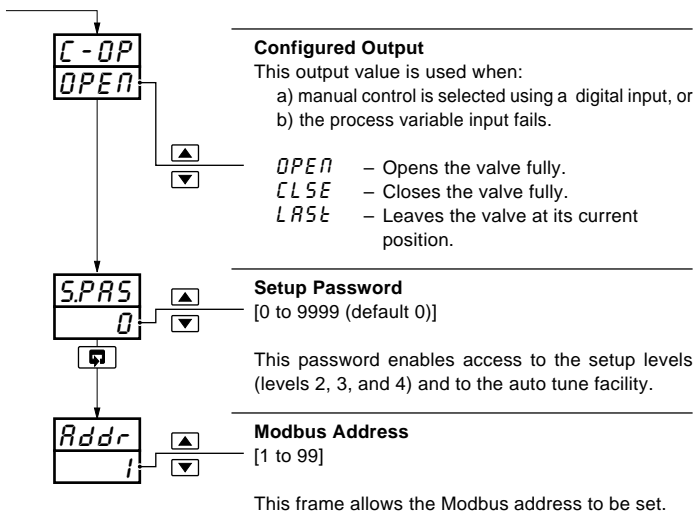



5.1 Siting – Figs. 5.1 and 5.2

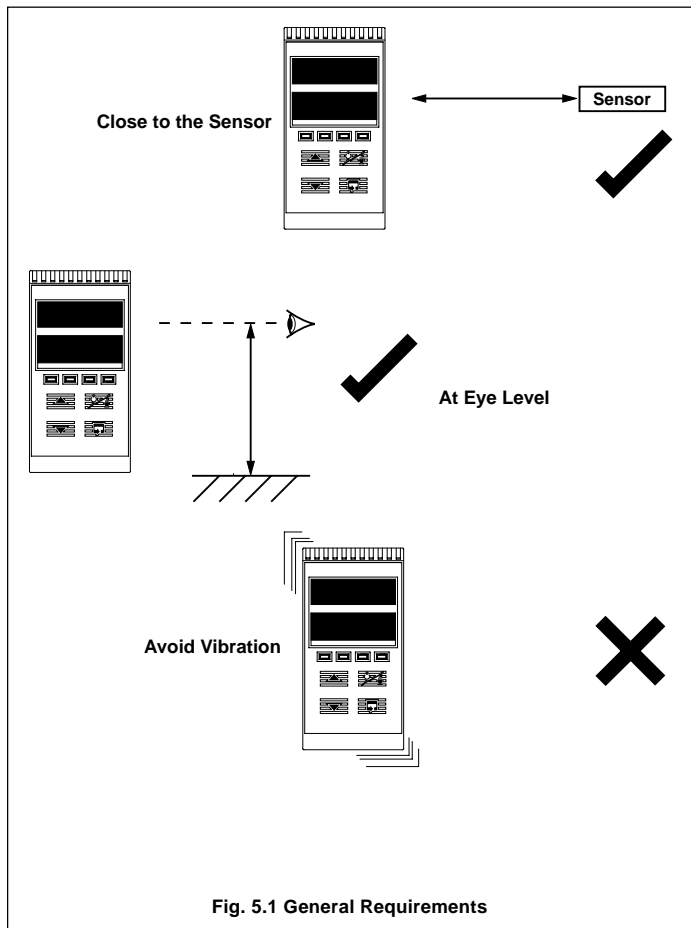



...5 INSTALLATION

...5.1 Siting – Figs. 5.1 and 5.2

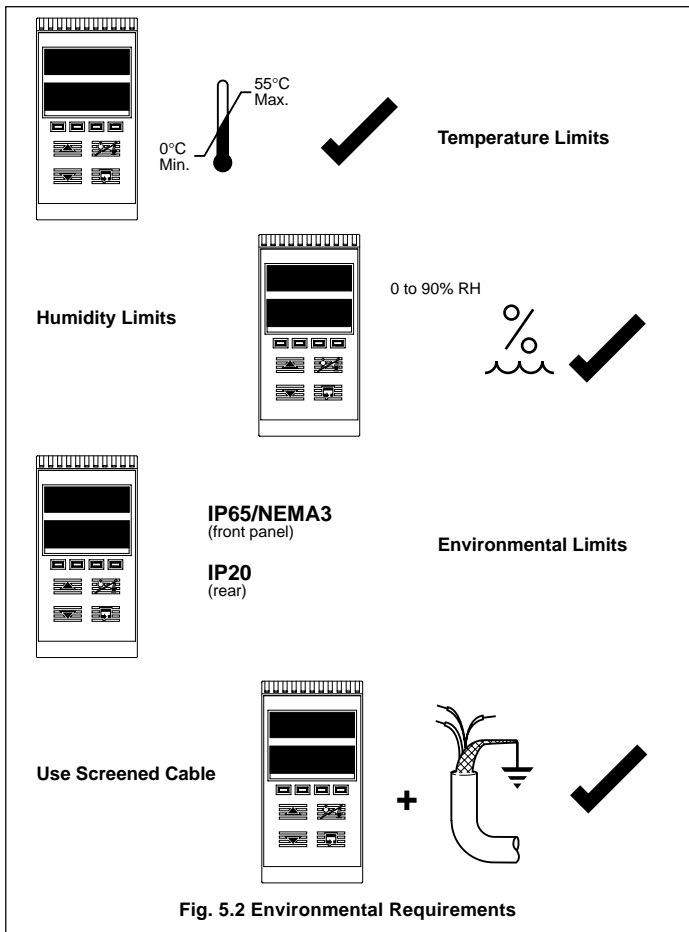



5.2 Mounting – Figs. 5.3 and 5.4

The instrument is designed for panel mounting (see Fig. 5.4). Overall dimensions are shown in Fig. 5.3.

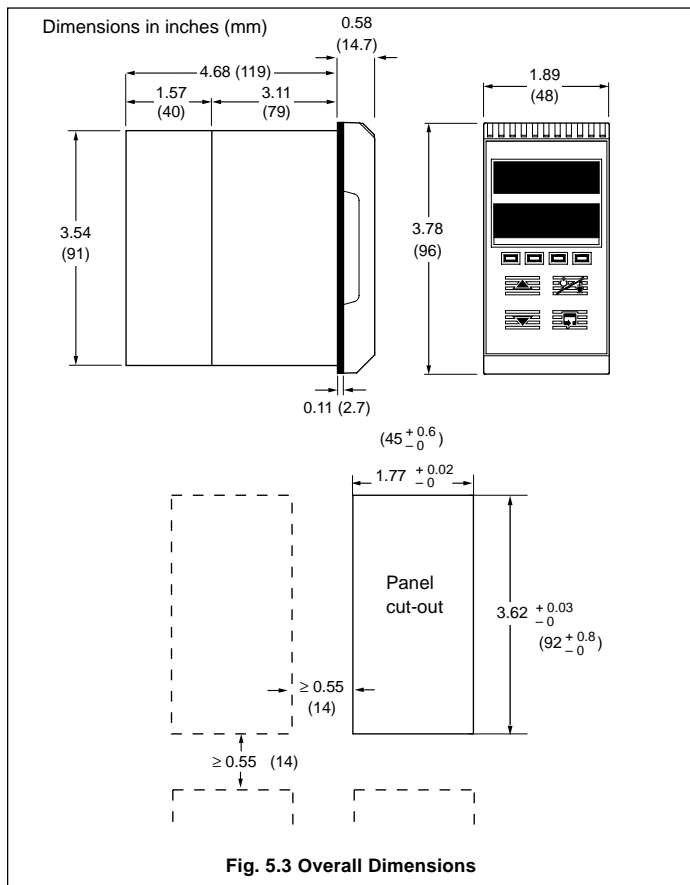



...5.2 Mounting – Figs. 5.3 and 5.4

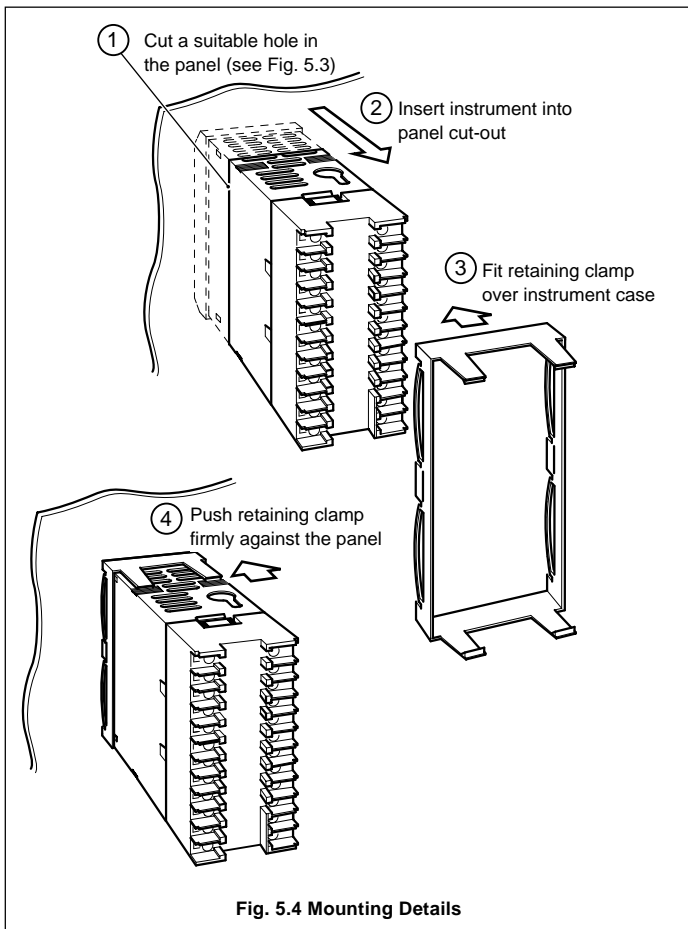

Fig. 5.4 Mounting Details



EC Directive 89/336/EEC

In order to meet the requirements of the EC Directive 89/336/EEC for EMC regulations, this product must not be used in a non-industrial environment.

5.3 Electrical Connections – Fig. 5.5 (overleaf)

Warning. Before making any connections, ensure that the power supply, any powered control circuits and high common mode voltages are switched off.

Note. If it is not possible to avoid strong electrical and magnetic fields, screened cables within earthed metal conduit must be used.

5.4 Relays, Arc Suppression, Inputs and Outputs

5.4.1 Relay Contact Ratings

Relay contacts are rated at:

115/230V AC at 5A (non-inductive).

250V DC 25W max.

5.4.2 Arc Suppression

Arc suppression components are fitted to relay outputs 2 and 3 only. The arc suppression components supplied must be fitted to relay output 1.

5.4.3 Logic Output

18V DC at 20mA, minimum load 900 Ω .

Isolated from inputs (not from analog O/P),

dielectric strength 500V d.c. for 1 minute.

5.4.4 Retransmission Analog Output

Max. load 15V (750 Ω at 20mA).

Isolated from inputs (not from logic O/P),

dielectric strength 500V d.c. for 1 minute.

5.4.5 Digital Input

Type: Volt-free

Minimum Pulse: 250ms



...5 INSTALLATION

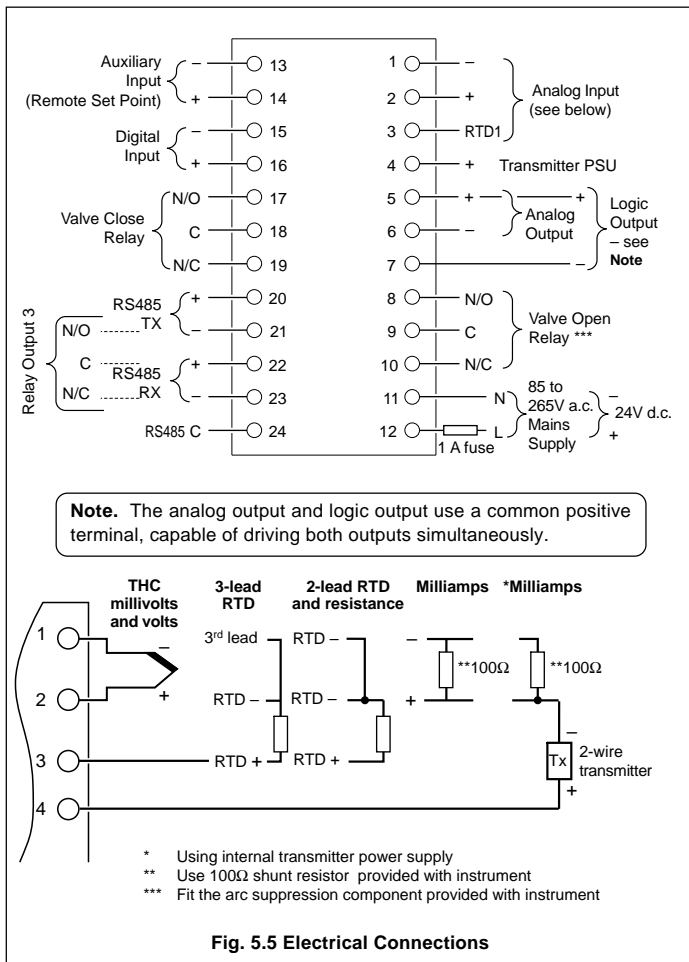

Fig. 5.5 Electrical Connections

Customer Support

We provide a comprehensive after sales service via our Worldwide Service Organization. Contact one of the following offices for details of your nearest Service and Repair Centre.

United Kingdom

ABB Limited
Tel: +44 (0)1480 475321
Fax: +44 (0)1480 217948

United States of America

ABB Inc.
Tel: +1 215 674 6000
Fax: +1 215 674 7183

Client Warranty

Prior to installation, the equipment referred to in this manual must be stored in a clean, dry environment, in accordance with the Company's published specification. Periodic checks must be made on the equipment's condition.

In the event of a failure under warranty, the following documentation must be provided as substantiation:

1. A listing evidencing process operation and alarm logs at time of failure.
2. Copies of all storage, installation, operating and maintenance records relating to the alleged faulty unit.

CUSTOMER SETUP LOG

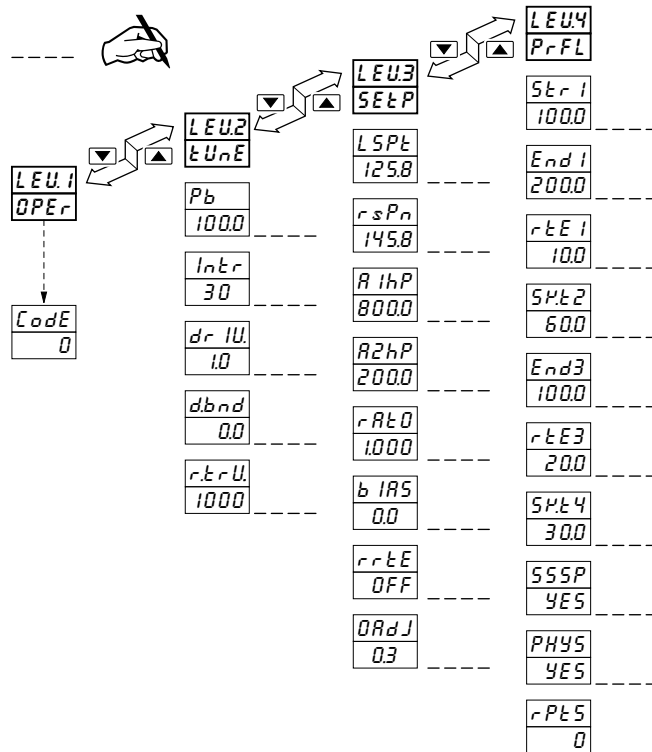

Company Standard settings are shown in the lower display

Instrument Serial Number: _____

Product Code: V 1 0 0 / _ _ _ _ / _ _ _ _



CUSTOMER CONFIGURATION LOG

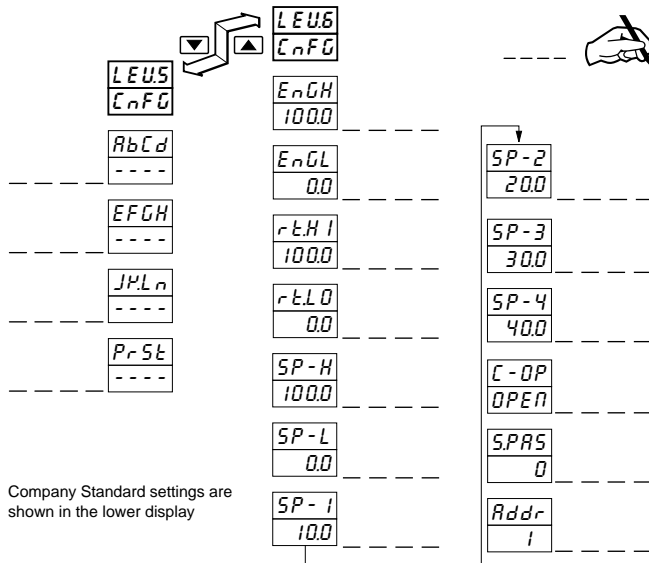

Company Standard settings are shown in the lower display

ABB has Sales & Customer Support expertise in over 100 countries worldwide

www.abb.com

The Company's policy is one of continuous product improvement and the right is reserved to modify the information contained herein without notice.

Printed in UK (03.05)

© ABB 2005



ABB Limited
 Howard Road, St. Neots
 Cambridgeshire
 PE19 8EU
 UK
 Tel: +44 (0)1480 475 321
 Fax: +44 (0)1480 217948

ABB Inc.
 125 E. County Line Road
 Warminster
 PA 18974
 USA
 Tel: +1 215 674 6000
 Fax: +1 215-674 7183