

C1900 Series Circular Chart Recorders and Recorder / Controllers

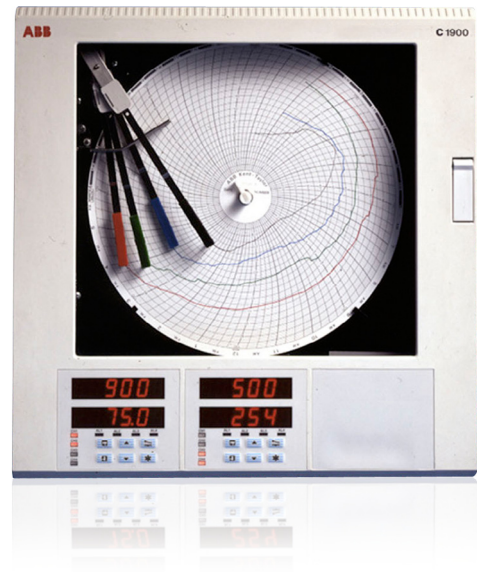

The Company

We are an established world force in the design and manufacture of measurement products for industrial process control, flow measurement, gas and liquid analysis and environmental applications.

As a part of ABB, a world leader in process automation technology, we offer customers application expertise, service and support worldwide.

We are committed to teamwork, high quality manufacturing, advanced technology and unrivalled service and support.

The quality, accuracy and performance of the Company's products result from over 100 years experience, combined with a continuous program of innovative design and development to incorporate the latest technology.

EN ISO 9001:2000



Cert. No. Q 05907

EN 29001 (ISO 9001)



Lenno, Italy – Cert. No. 9/90A

Stonehouse, U.K.



0255

Electrical Safety

This equipment complies with the requirements of CEI/IEC 61010-1:2001-2 'Safety Requirements for Electrical Equipment for Measurement, Control and Laboratory Use'. If the equipment is used in a manner NOT specified by the Company, the protection provided by the equipment may be impaired.

Symbols

One or more of the following symbols may appear on the equipment labelling:

	Warning – Refer to the manual for instructions
	Caution – Risk of electric shock
	Protective earth (ground) terminal
	Earth (ground) terminal

	Direct current supply only
	Alternating current supply only
	Both direct and alternating current supply
	The equipment is protected through double insulation

Information in this manual is intended only to assist our customers in the efficient operation of our equipment. Use of this manual for any other purpose is specifically prohibited and its contents are not to be reproduced in full or part without prior approval of the Technical Publications Department.

Health and Safety

To ensure that our products are safe and without risk to health, the following points must be noted:

1. The relevant sections of these instructions must be read carefully before proceeding.
2. Warning labels on containers and packages must be observed.
3. Installation, operation, maintenance and servicing must only be carried out by suitably trained personnel and in accordance with the information given.
4. Normal safety precautions must be taken to avoid the possibility of an accident occurring when operating in conditions of high pressure and/or temperature.
5. Chemicals must be stored away from heat, protected from temperature extremes and powders kept dry. Normal safe handling procedures must be used.
6. When disposing of chemicals ensure that no two chemicals are mixed.

Safety advice concerning the use of the equipment described in this manual or any relevant hazard data sheets (where applicable) may be obtained from the Company address on the back cover, together with servicing and spares information.

CONTENTS

Section	Page
1 INTRODUCTION	1
2 PREPARATION	2
2.1 Accessories	2
2.2 Checking the Code Number	2
2.2.1 Non-upgradeable Version	2
3 MECHANICAL INSTALLATION	3
3.1 Siting	3
3.2 Mounting	3
3.2.1 Wall-/Pipe-Mounting	4
3.2.2 Panel Mounting	5
4 ELECTRICAL INSTALLATION	6
4.1 Identifying the Input/Output Modules	7
4.2 Channel Connections	7
4.2.1 Selecting the Analog Input Type(s)	8
4.2.2 Voltage and Current	9
4.2.3 2-wire Transmitter Input	9
4.2.4 Thermocouple	9
4.2.5 Resistance Thermometer (RTD)	9
4.2.6 Logic Inputs	9
4.2.7 Analog Output	9
4.2.8 Relay Output	9
4.2.9 Motorized Valve	10
4.3 Module Connections	11
4.3.1 Standard I/O or Analog + Relay (Module Types 1, 2 and 7)	11
4.3.2 Four Relay Module (Module Type 3)	11
4.3.3 Eight Digital Inputs or Outputs (Module Types 4 and 5 respectively)	11
4.4 Power Supply Connections	13
5 INSTALLATION RECORD	13

1 INTRODUCTION

The documentation for the C1900 series of circular chart recorders is shown in Fig. 1.1. The **Standard Manuals**, including the data sheet, are supplied with all instruments. The **Supplementary Manuals** supplied depend on the specification of the instrument.

This manual includes an **Installation Record** which should be completed as a log of the electrical installation. The record is useful when carrying out initial instrument programming and can be retained for future reference.

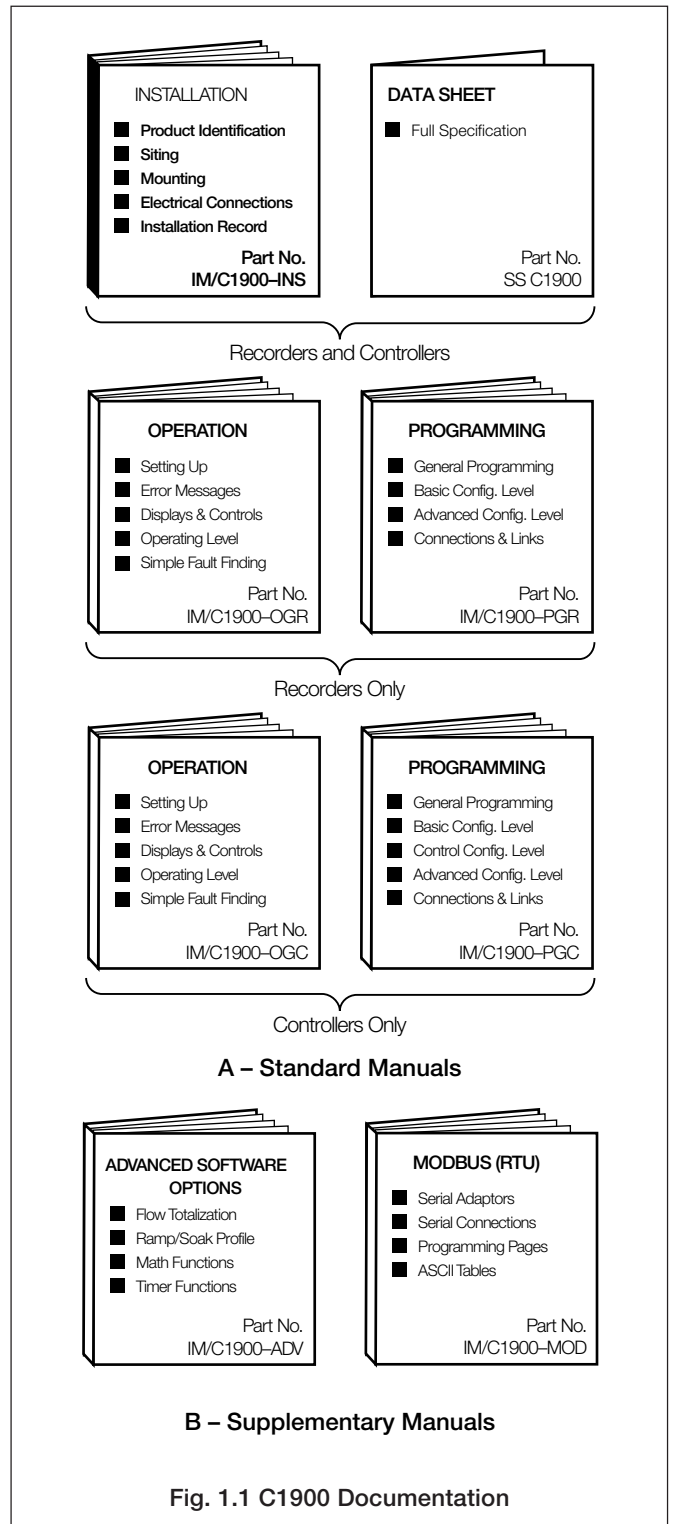
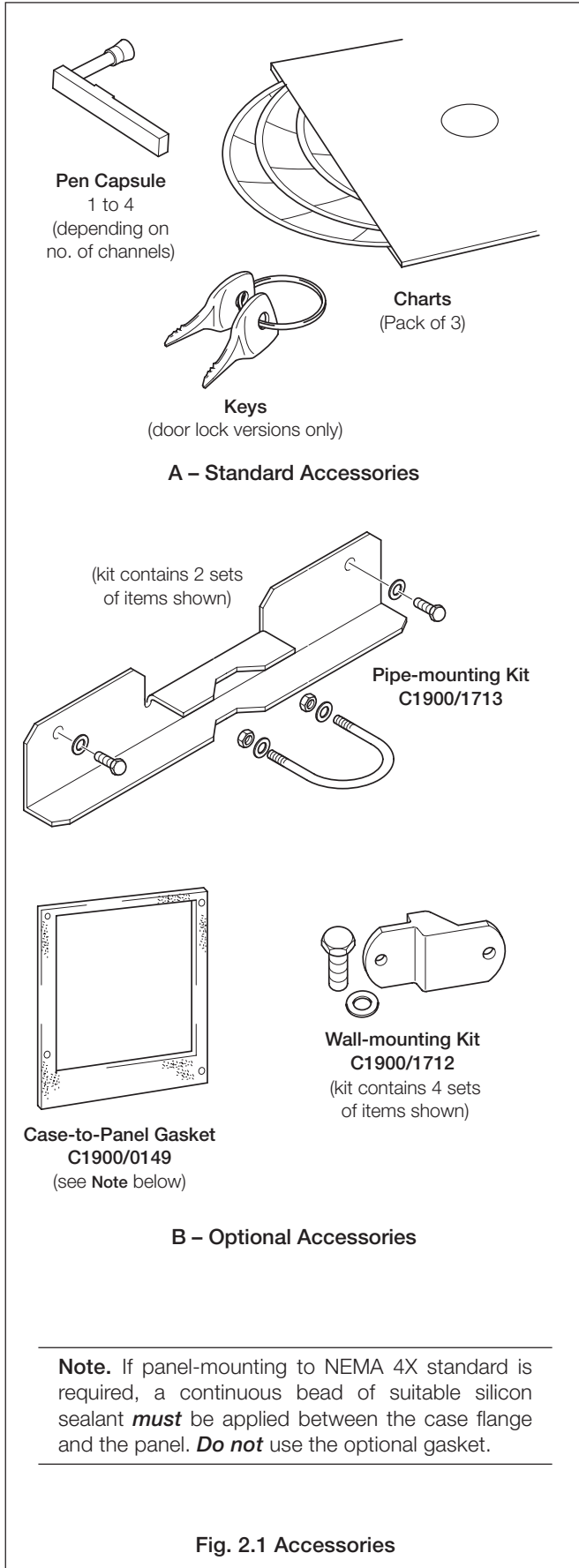

Fig. 1.1 C1900 Documentation

2 PREPARATION

2.1 Accessories – Fig. 2.1



2.2 Checking the Code Number – Fig. 2.2

2.2.1 Non-upgradeable Version

Note. The 1901J is a basic, non-upgradeable single pen recorder. This version is not fitted with an analog output, relay, transmitter power supply unit or digital inputs and no additional modules can be fitted. The full identification code is shown below.

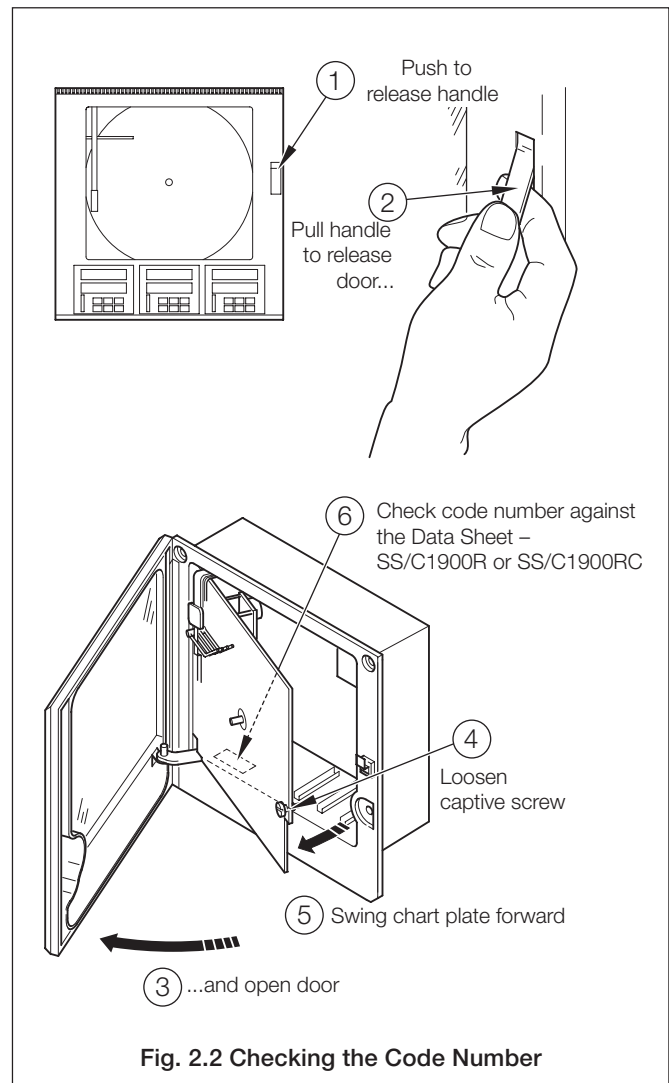
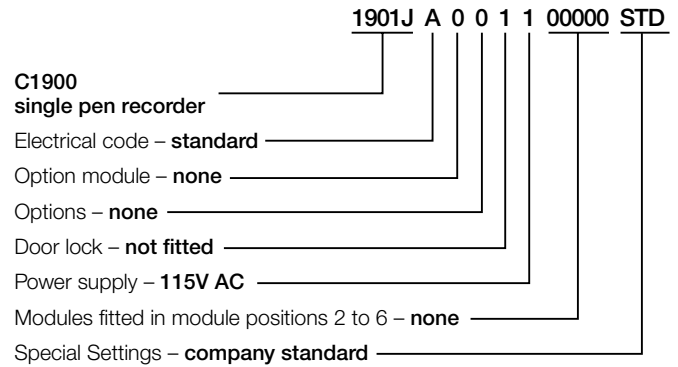

3 MECHANICAL INSTALLATION

3.1 Siting – Figs 3.1 and 3.2

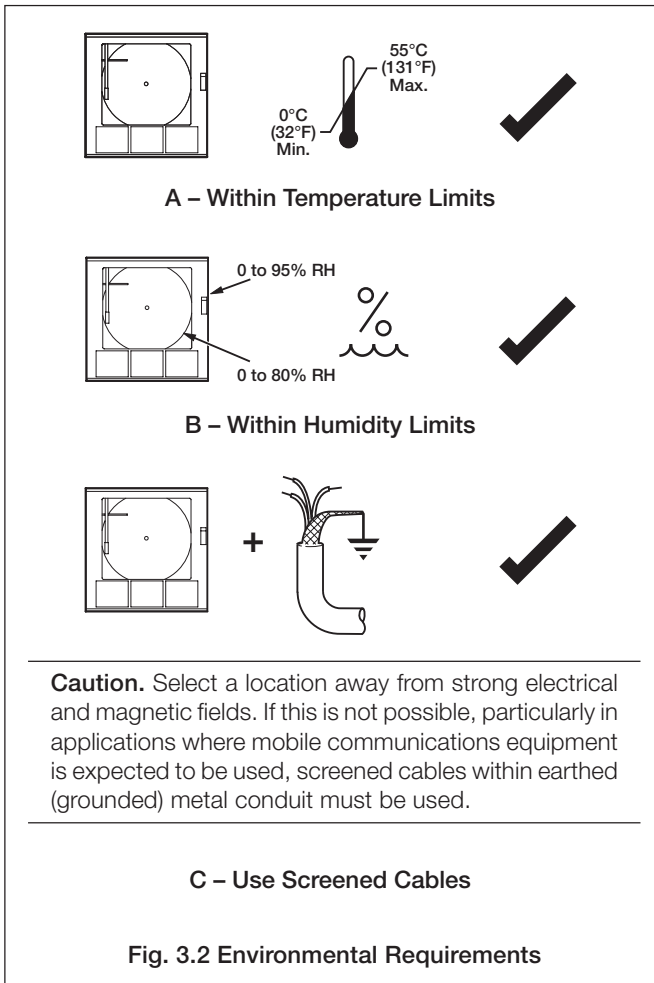
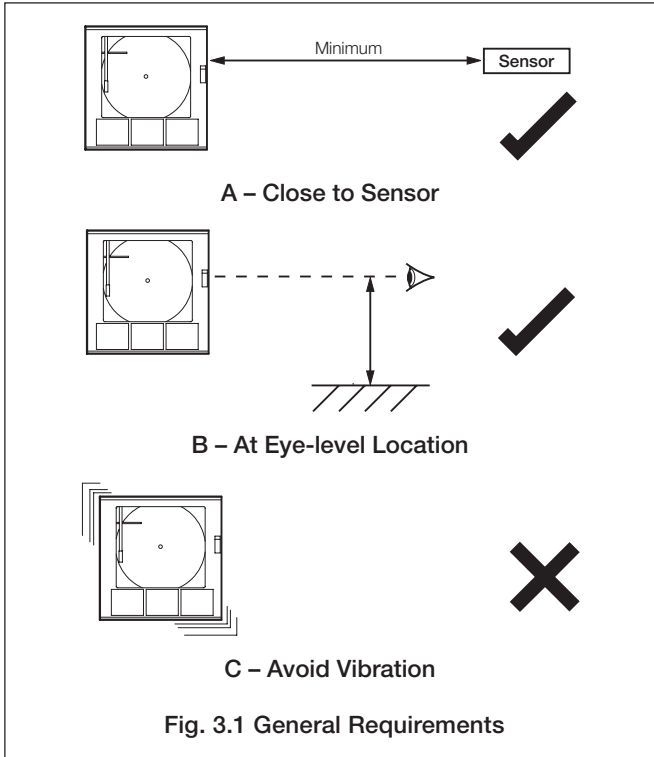

3.2 Mounting – Figs. 3.3 to 3.5

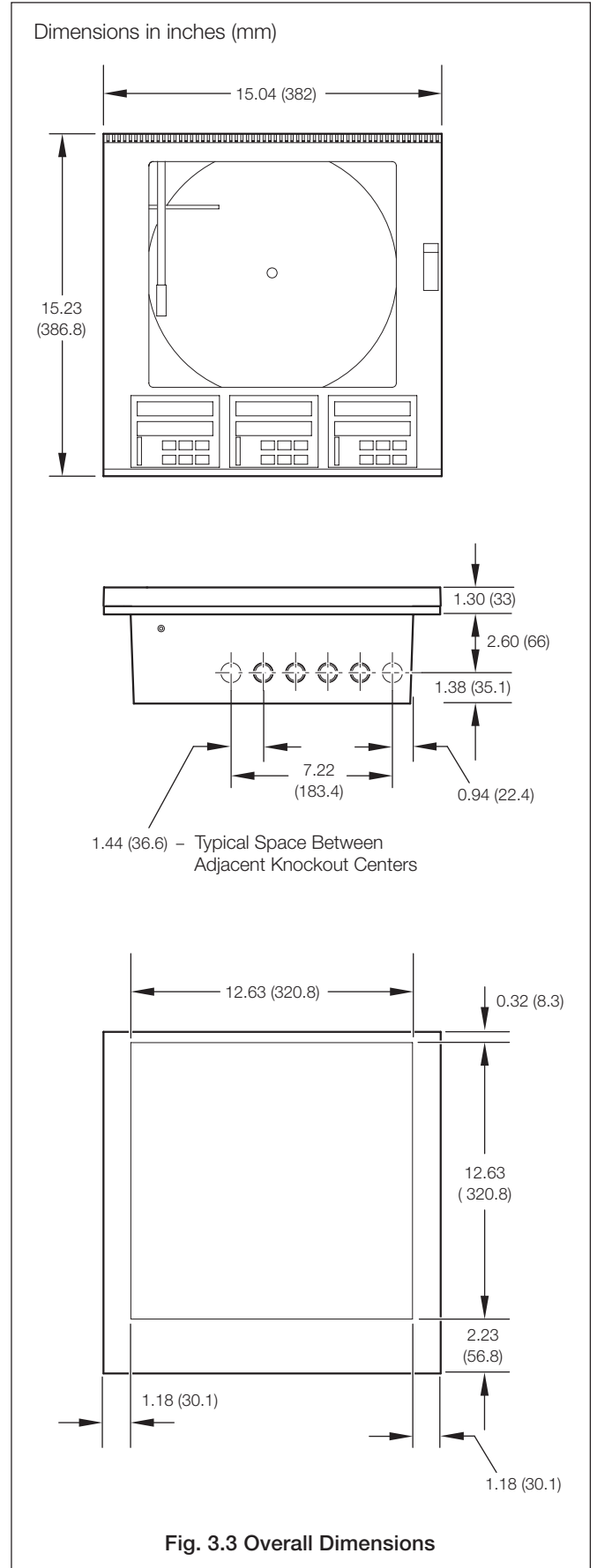

3.2.1 Wall-/Pipe-Mounting – Fig. 3.4

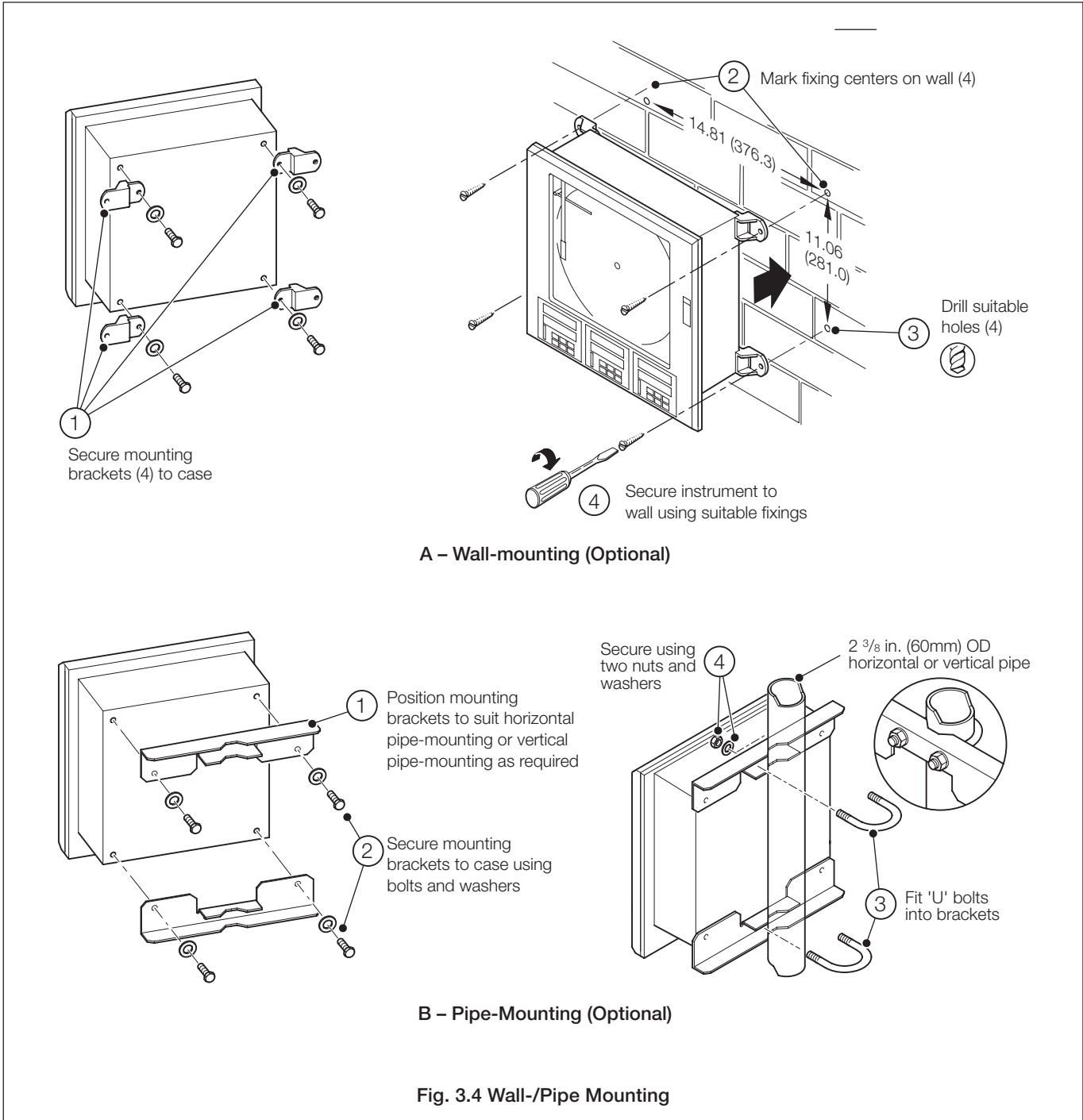

3.2.2 Panel Mounting – Fig. 3.5

Dimensions in inches (mm)

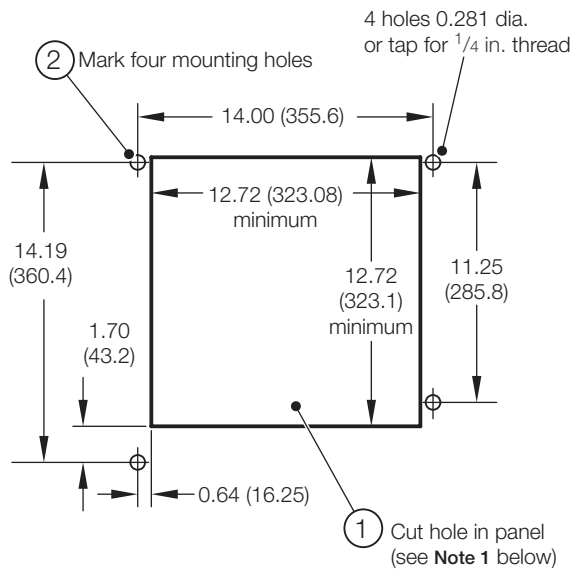

Minimum Cut-out Dimensions

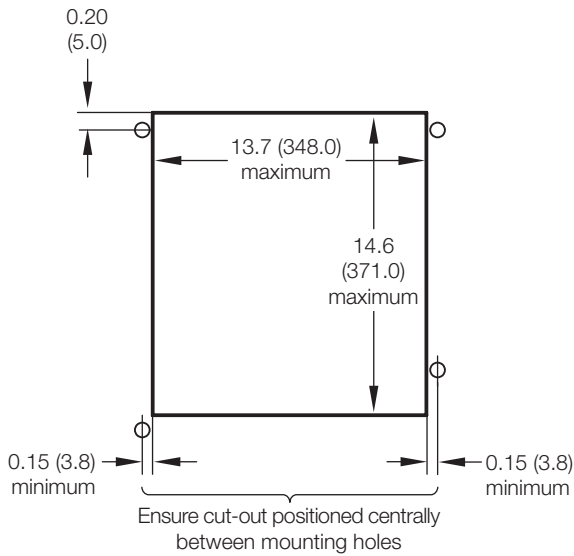

Maximum Cut-out Dimensions

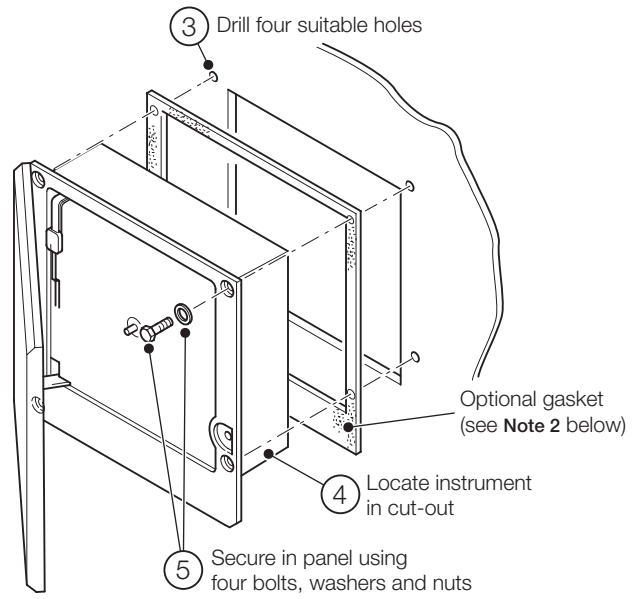

Notes.

1. The instrument can be inserted into a panel cut-out of any size between the minimum and maximum dimensions illustrated, provided the cut-out is positioned centrally relative to the fixing holes. If the panel cut-out is larger than the maximum, a locally manufactured adaptor plate will be required.
2. If panel-mounting to NEMA 4X hosedown standard is required, a continuous bead of suitable silicon sealant **must** be applied between the case flange and the panel. **Do not** use the optional gasket.

Fig. 3.5 Panel Mounting

4 ELECTRICAL INSTALLATION



Warnings.

- To comply with Underwriter Laboratories (UL) and Canadian Standards Association (CSA) certification, route signal leads and power cables in earthed (grounded), flexible metal conduit. Use the Position 1 protective ground stud \oplus (NOT the terminal module ground stud) to ground the flexible metal conduit.
- Instruments not fitted with the optional internal on/off switch and fuse must have a disconnecting device such as a switch or circuit breaker conforming to local safety standards fitted to the final installation. It must be fitted in close proximity to the instrument within easy reach of the operator and must be marked clearly as the disconnection device for the instrument.
- Remove all power from supply, relay and any powered control circuits and high common mode voltages before accessing or making any connections.
- Use cable appropriate for the load currents. The terminals accept cables up to 14AWG (2.5mm²).
- The instrument and all inputs and outputs conform to Mains Power Input Insulation Category II.
- All connections to secondary circuits must have basic insulation.
- After installation, there must be no access to live parts e.g. terminals.
- Terminals for external circuits are for use only with equipment with no accessible live parts.
- If the instrument is used in a manner not specified by the Company, the protection provided by the equipment may be impaired.
- All equipment connected to the instrument's terminals must comply with local safety standards (IEC 60950, EN601010-1).

Notes.

- Always route signal leads and power cables separately.
- Use screened cable for signal inputs and relay connections. Connect the screen to the earth (ground) stud – see Fig. 4.10.
- The terminal blocks can be removed from the main PCB when making connections – see Fig. 4.1. Before removing a module, note its position.
- If wall- or pipe-mounting to NEMA 4X hosedown standard is required, suitable cable glands must be used to prevent water ingress.

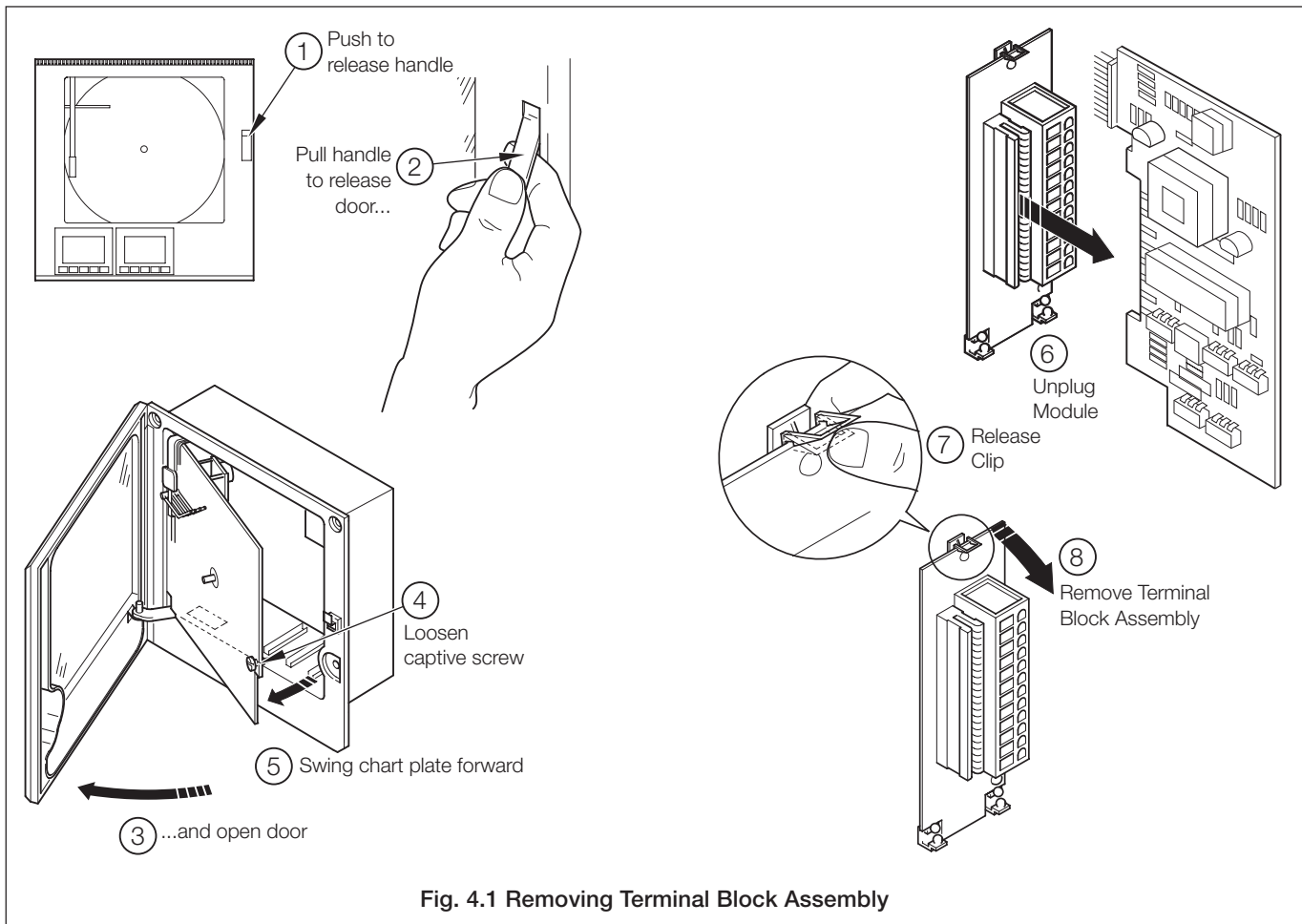

Fig. 4.1 Removing Terminal Block Assembly

4.1 Identifying the Input/Output Modules – Fig. 4.2

To gain access to the modules, open the door and chassis – see Fig. 2.2. There are six module positions as shown in Fig. 4.2.

4.2 Channel Connections

Channel 1 connections are made directly to the terminal block mounted on the motherboard.

Other Channel connections are made to standard I/O modules, fitted in positions 2, 3 or 4 – see Fig. 4.2.



Warning. The maximum channel to channel voltage (between any 2 channels) must not exceed 500V DC.

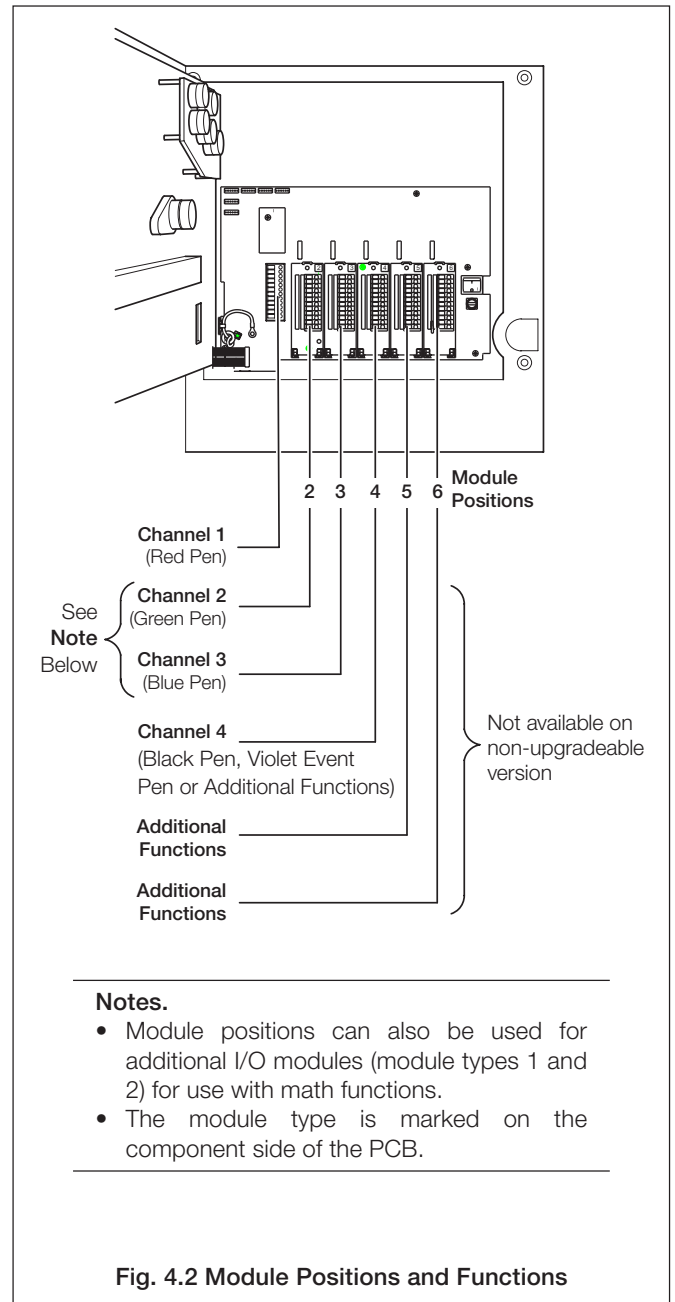

...4 ELECTRICAL INSTALLATION

4.2.1 Selecting the Analog Input Type(s) – Figs. 4.3 and 4.4

Plug-in links are used to select the input type:

- Channel 1** PL1 & PL8 on the main p.c.b. (Fig. 4.3)
- Channels 2 to 4** PL1 & PL3 on the module (Fig. 4.4)

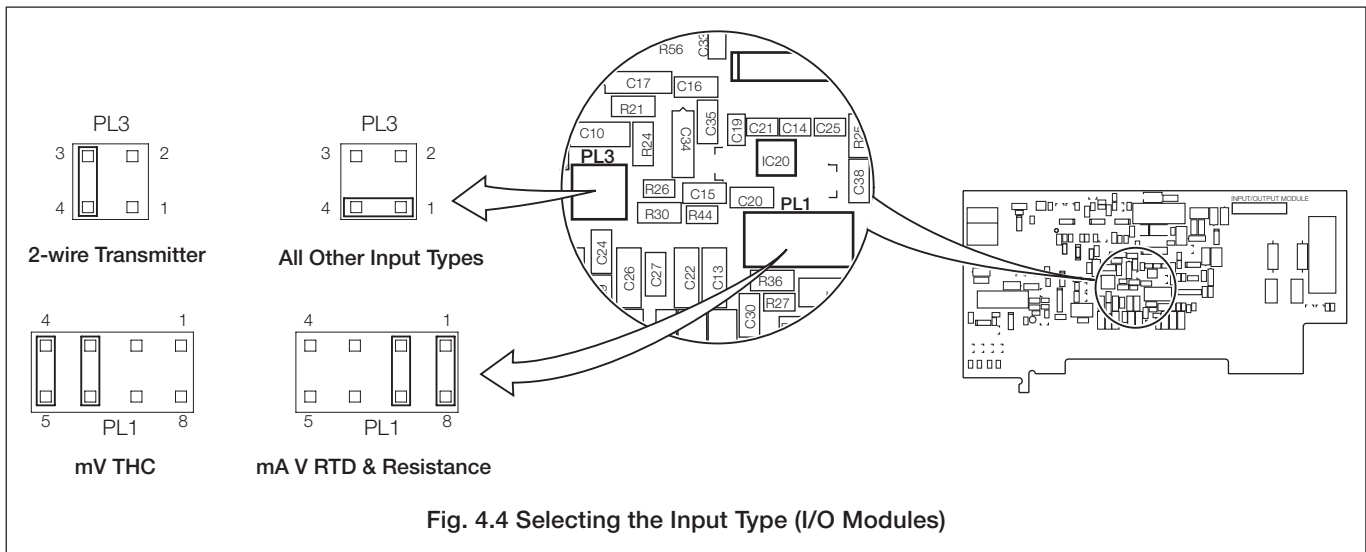
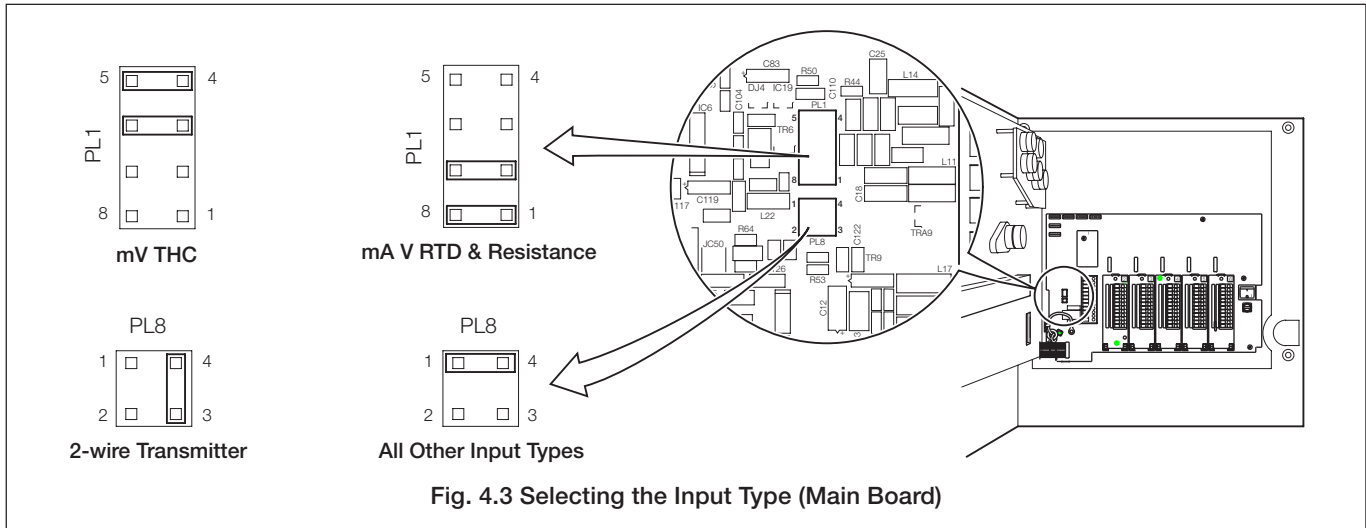

Type of Thermocouple	Compensating Cable											
	BS1843			ANSI MC 96.1			DIN 43714			BS4937 Part No.30		
	+	-	Case	+	-	Case	+	-	Case	+	-	Case
Ni-Cr/Ni-Al (K)	Brown	Blue	Red	Yellow	Red	Yellow	Red	Green	Green	Green	White	Green*
Ni-Cr/Cu-Ni (E)		—			—			—		Violet	White	Violet*
Nicrisil/Nisil (N)	Orange	Blue	Orange	Orange	Red	Orange		—		Pink	White	Pink
Pt/Pt-Rh (R and S)	White	Blue	Green	Black	Red	Green	Red	White	White	Orange	White	Orange*
Pt-Rh/Pt-Rh (B)		—			—			—		Grey	White	Grey*
Cu/Cu-Ni (T)	White	Blue	Blue	Blue	Red	Blue	Red	Brown	Brown	Brown	White	Brown*
Fe/Con (J)	Yellow	Blue	Black	White	Red	Black	Red	Blue	Blue	Black	White	Black*
* Case Blue for intrinsically safe circuits												
Fe/Con (DIN 43710)		—			—		DIN 43710				—	
							Blue/Red	Blue	Blue			

Table 4.1 Thermocouple Compensating Cable

4.2.2 Voltage and Current – Fig. 4.5

Input impedances:

Low voltage (mV)	>10MΩ
Voltage	>10MΩ
Current (mA)	100Ω

4.2.3 2-wire Transmitter Input – Fig. 4.5

Power for the transmitter is supplied by terminal 6.

Note. The voltage across terminals 4 and 6 is 20V (nominal). This is due to internal voltage drops across a shunt resistor and measurement circuitry.

4.2.4 Thermocouple – Fig. 4.5

Use correct compensating cable between the thermocouple and the terminals – see Table 4.1 (previous page).

Automatic cold junction (ACJC) is incorporated but an independent cold (reference) junction may be used.

4.2.5 Resistance Thermometer (RTD) – Fig. 4.5

If long leads are necessary it is preferable to use a 3-lead resistance thermometer.

If 2-lead resistance thermometers are used each input must be calibrated to take account of the lead resistance.

4.2.6 Logic Inputs – Fig. 4.5

The two logic inputs accept either volt-free (switch) or TTL (5V) input types and can be used for remote switching of many recorder functions, e.g. chart stop/go, alarm acknowledgment, totalizer reset etc. Refer to the **Programming Guide**, IM/C1900-PGR or IM/C1900-PGC.

4.2.7 Analog Output – Fig. 4.5

4.2.8 Relay Output – Fig. 4.5

Relay specification:

Type	single pole changeover	
Voltage	250V AC	250V DC
Current	5A AC	5A DC
Loading (non inductive)	1250VA	50W
Isolation, contacts to earth	2kV RMS	

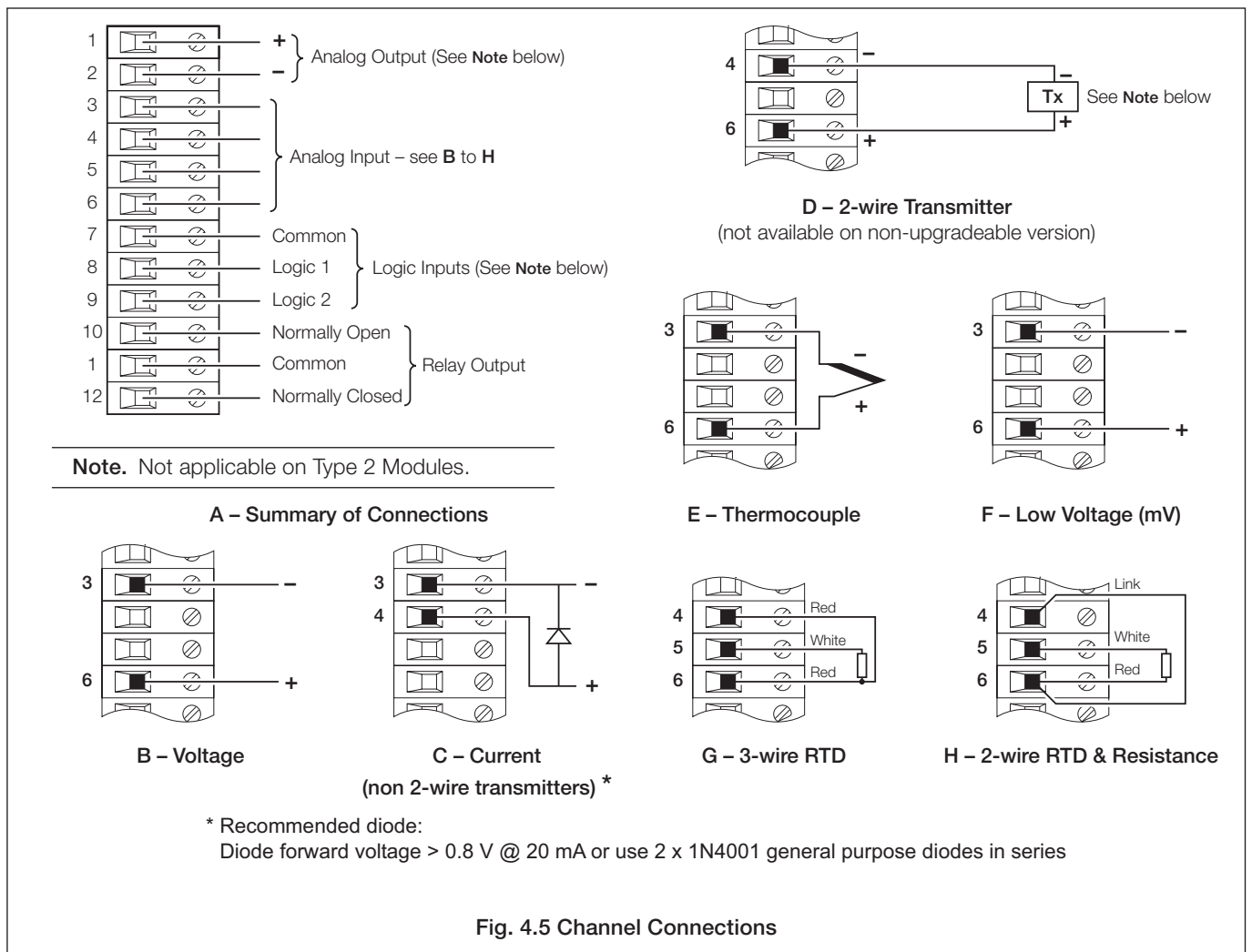
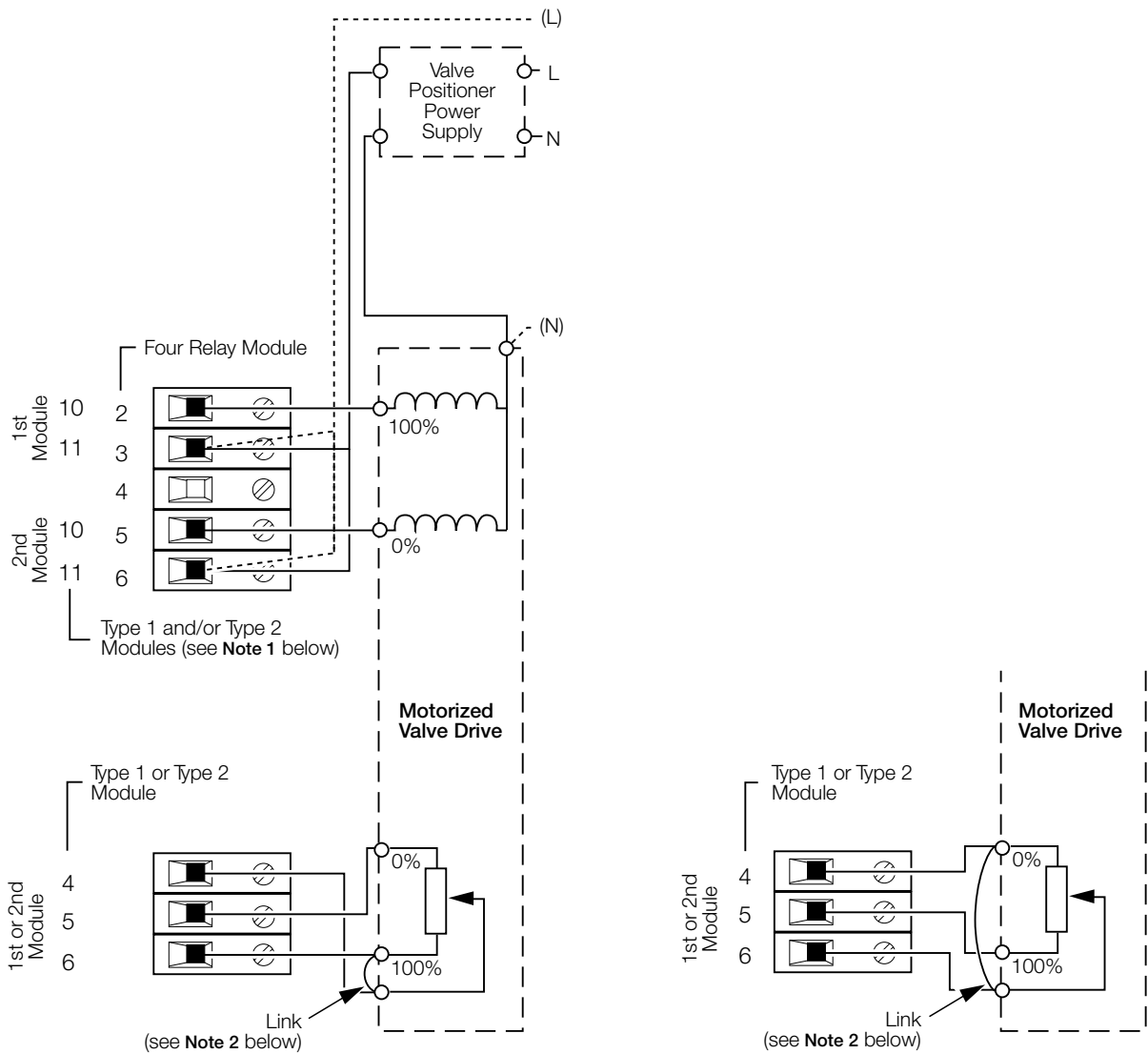

Fig. 4.5 Channel Connections

4.2.9 Motorized Valve – Fig. 4.6

A motorized valve with or without feedback requires 2 relays (common and normally open terminals) to drive the valve in either direction. Any two relays can be allocated for this function. Fig. 4.6 A shows two possible combinations.

Note. For valves with position feedback using low voltage (mV), voltage (V) or current (C), refer to Fig. 4.5 B, C and F for connections.



A – Standard Feedback Slidewire Configuration

B – Alternative Feedback Slidewire Configuration

Notes.

- 1 Type 1 and type 2 modules have one relay output, therefore two modules are required.
- 2 Link must be connected at valve drive end, not at the controller terminals.

Fig 4.6 Motorized Valve Connections (using feedback slidewire)

4.3 Module Connections

4.3.1 Standard I/O or Analog + Relay (Module Types 1, 2 and 7) – Fig. 4.5

The connections are the same as Channel connections to the main board. Refer to Section 4.2.

4.3.2 Four Relay Module (Module Type 3) – Fig. 4.7

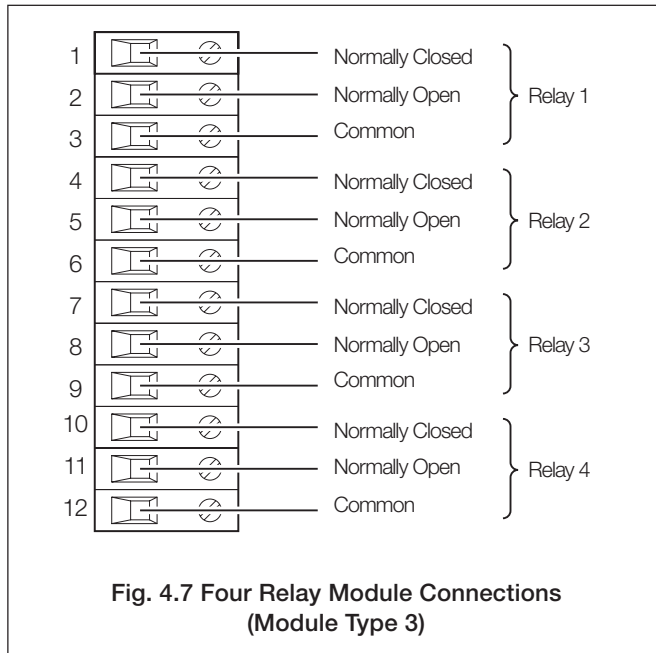

4.3.3 Eight Digital Inputs or Outputs (Module Types 4 and 5 respectively) – Figs. 4.8 and 4.9

A plug-in link is used to select the board's function; digital inputs or digital outputs – see Fig. 4.8. The maximum current drain from each TTL output must not exceed 5mA.

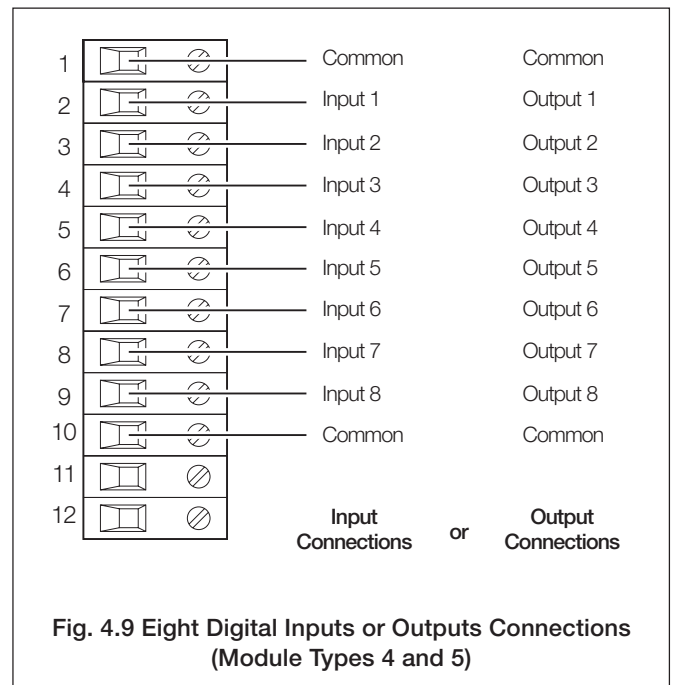
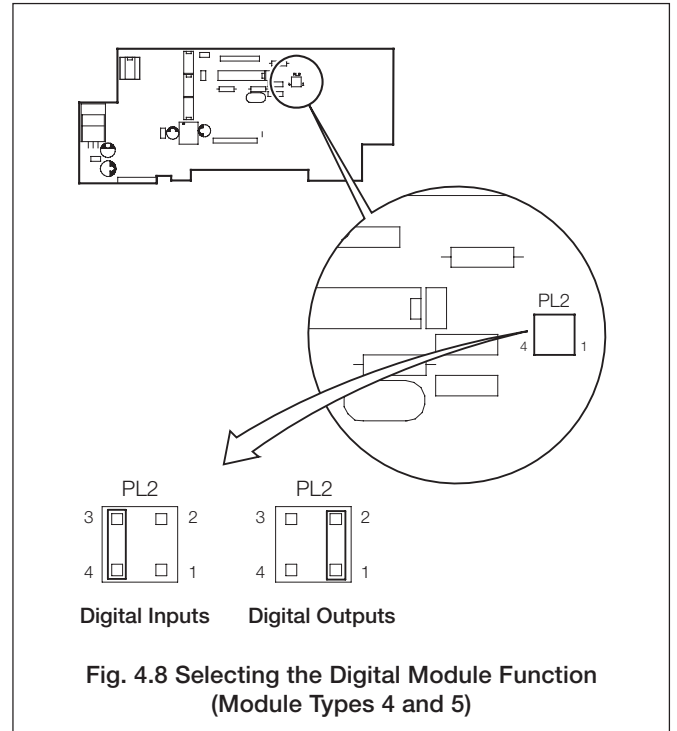

4.4 Power Supply Connections – Fig. 4.10

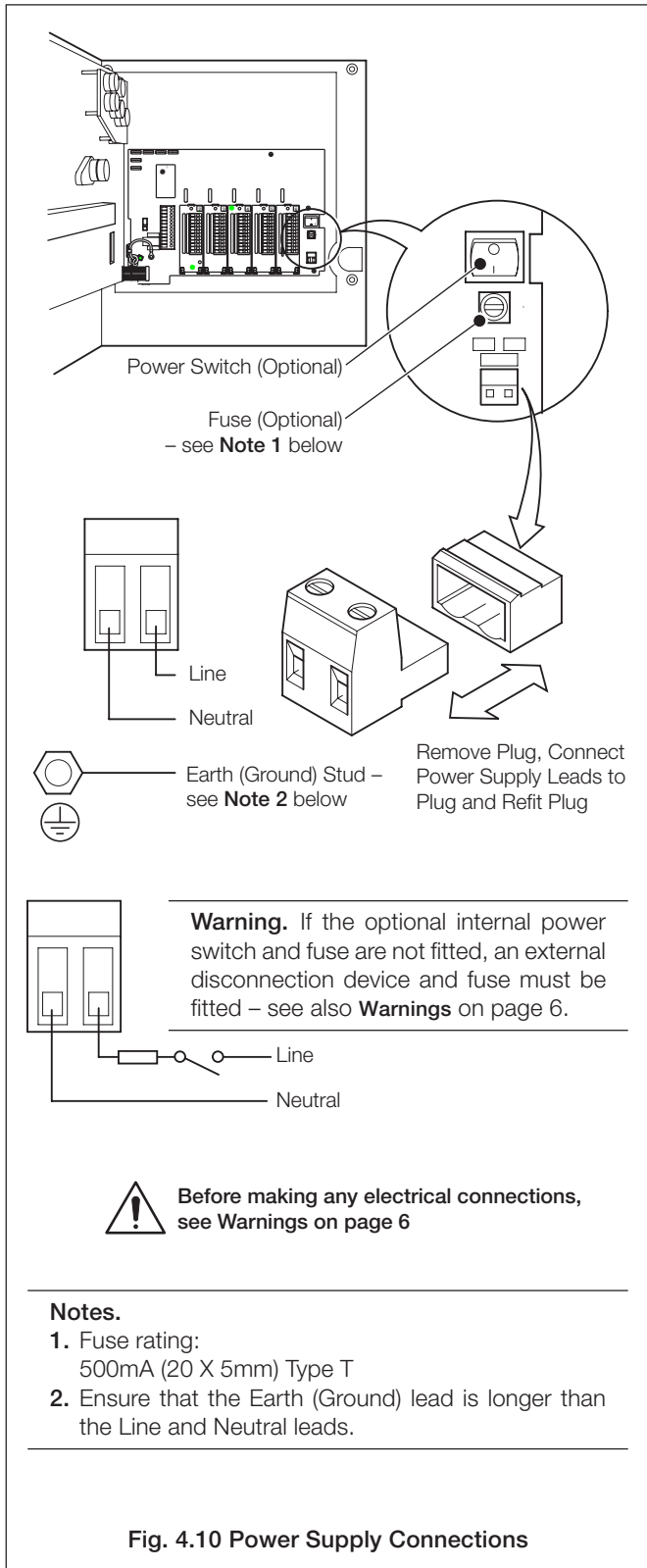

Note. Recorders manufactured before June 2005 are fitted with a Mainboard that is not equipped with a universal power supply. Ensure the supply voltage selector switch is set correctly and the appropriate fuse is fitted – see Fig 4.11.

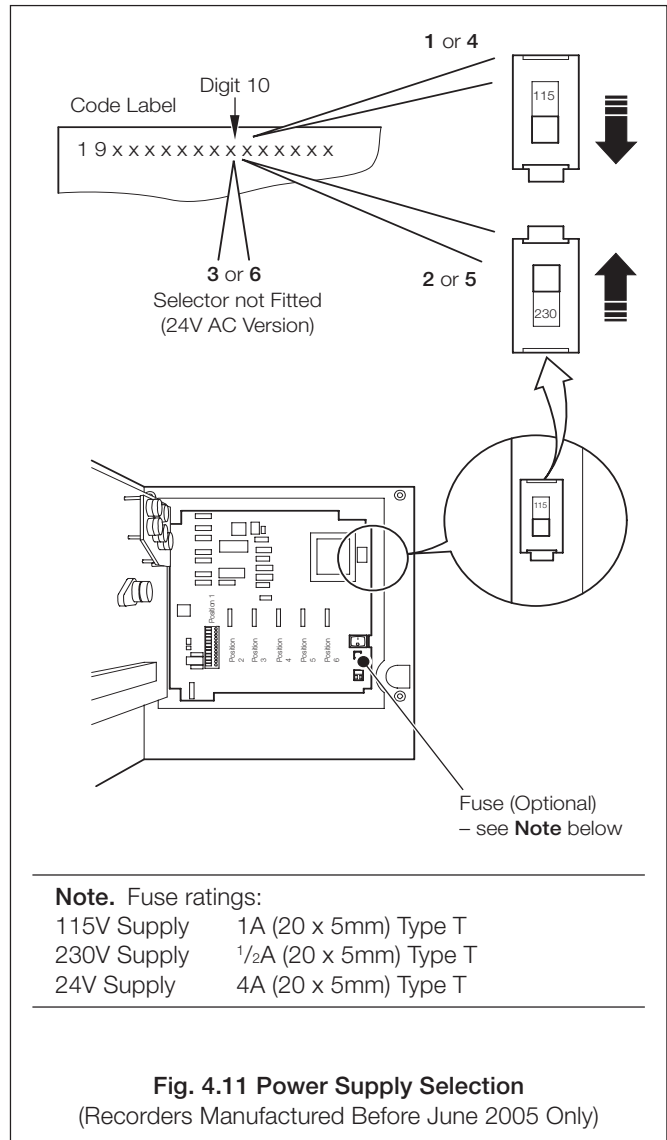

5 INSTALLATION RECORD

Position 1

Module Type 1

1	+	
2	-	
3		
4	Analog Input	
5		
6		
7	C	
8	L1	
9	L2	
10	NO	
1	C	
12	NC	

Position 2

Module Type 1 2

1	+	
2	-	
3		
4	Analog Input	
5		
6		
7	C	
8	L1	
9	L2	
10	NO	
1	C	
12	NC	

Position 3

Module Type 1 2

1	+	
2	-	
3		
4	Analog Input	
5		
6		
7	C	
8	L1	
9	L2	
10	NO	
1	C	
12	NC	

* Not applicable on Module Type 2

* Not applicable on Module Type 2

Position 4

Module Type 1 2 6 7

1	+	
2	-	
3		
4	Analog Input	
5		
6		
7	C	
8	L1	
9	L2	
10	NO	
1	C	
12	NC	

* Not applicable on Module Type 2

4 5

1	C	
2	1	
3	2	
4	3	
5	4	
6	5	
7	6	
8	7	
9	8	
10	C	

Logic I/Ps (Type 4) or Logic O/Ps (Type 5)

Link Positions (Tick Box)	
	Type 4
	Type 5

Position 5

Module Type (Tick Box) 2

1	+	
2	-	
3		Link Positions (Tick Boxes)
4		
5		
6		
7	C	
8	L1	
9	L2	
10	NO	
1	C	
12	NC	

* Not available on Module Type 2

3

1	NC	
2	NO	
3	C	
4	NC	
5	NO	
6	C	
7	NC	
8	NO	
9	C	
10	NC	
1	NO	
12	C	

4 5

1	C	
2	1	
3	2	
4	3	
5	4	
6	5	
7	6	
8	7	
9	8	
10	C	

Logic I/Ps (Type 4) or Logic O/Ps (Type 5)

Link Positions (Tick Box)
 Type 4 Type 5

Position 6

Module Type (Tick Box) 2

1	+	
2	-	
3		Link Positions (Tick Boxes)
4		
5		
6		
7	C	
8	L1	
9	L2	
10	NO	
1	C	
12	NC	

* Not available on Module Type 2

4 5

1	C	
2	1	
3	2	
4	3	
5	4	
6	5	
7	6	
8	7	
9	8	
10	C	

Logic I/Ps (Type 4) or Logic O/Ps (Type 5)

Link Positions (Tick Box)
 Type 4 Type 5

NOTES

Products and customer support

Automation Systems

For the following industries:

- Chemical & Pharmaceutical
- Food & Beverage
- Manufacturing
- Metals and Minerals
- Oil, Gas & Petrochemical
- Pulp and Paper

Drives and Motors

- AC and DC Drives, AC and DC Machines, AC Motors to 1kV
- Drive Systems
- Force Measurement
- Servo Drives

Controllers & Recorders

- Single and Multi-loop Controllers
- Circular Chart and Strip Chart Recorders
- Paperless Recorders
- Process Indicators

Flexible Automation

- Industrial Robots and Robot Systems

Flow Measurement

- Electromagnetic Flowmeters
- Mass Flowmeters
- Turbine Flowmeters
- Wedge Flow Elements

Marine Systems & Turbochargers

- Electrical Systems
- Marine Equipment
- Offshore Retrofit and Refurbishment

Process Analytics

- Process Gas Analysis
- Systems Integration

Transmitters

- Pressure
- Temperature
- Level
- Interface Modules

Valves, Actuators and Positioners

- Control Valves
- Actuators
- Positioners

Water, Gas & Industrial Analytics Instrumentation

- pH, Conductivity and Dissolved Oxygen Transmitters and Sensors
- Ammonia, Nitrate, Phosphate, Silica, Sodium, Chloride, Fluoride, Dissolved Oxygen and Hydrazine Analyzers
- Zirconia Oxygen Analyzers, Katharometers, Hydrogen Purity and Purge-gas Monitors, Thermal Conductivity

Customer support

We provide a comprehensive after sales service via a Worldwide Service Organization. Contact one of the following offices for details on your nearest Service and Repair Centre.

UK

ABB Limited
Tel: +44 (0)1453 826661
Fax: +44 (0)1453 829671

USA

ABB Inc.
Tel: +1 215 674 6000
Fax: +1 215 674 7183

Client Warranty

Prior to installation, the equipment referred to in this manual must be stored in a clean, dry environment, in accordance with the Company's published specification. Periodic checks must be made on the equipment's condition. In the event of a failure under warranty, the following documentation must be provided as substantiation:

- A listing evidencing process operation and alarm logs at time of failure.
- Copies of all storage, installation, operating and maintenance records relating to the alleged faulty unit.

Contact us

To find your local ABB contact visit:

www.abb.com/contacts

For more product information visit:

www.abb.com

Note

We reserve the right to make technical changes or modify the contents of this document without prior notice. With regard to purchase orders, the agreed particulars shall prevail. ABB does not accept any responsibility whatsoever for potential errors or possible lack of information in this document.

We reserve all rights in this document and in the subject matter and illustrations contained therein. Any reproduction, disclosure to third parties or utilization of its contents in whole or in parts - is forbidden without prior written consent of ABB.

Copyright© 2010 ABB

All rights reserved

IM/C1900-INS Rev. N 06.2010