

In this application, the concentration of organics would be measured at the outlet of the carbon filter to monitor the correct performance. Typically, readings would be less than 1mg/litre and the low range monitor would be used for this application.

Suitable valving and/or pressure reduction equipment may be necessary, depending on the particular plant conditions.

Why use UV Absorption Monitors on a Carbon Filter

- ▶ To determine when the carbon filter needs replacement carbon powder.
- ▶ To measure the effectiveness of the treatment plant.
- ▶ To monitor the final water as a further verification of water quality.
- ▶ To monitor the efficiency of the carbon filter.
- ▶ To protect against breakthrough of organisms in the final water.
- ▶ To ensure compliance with drinking water standards.

Why use ABB Instrumentation?

- ▶ Utilises auto cleaning to prevent optical fouling.
- ▶ Works reliably even with high levels of manganese and iron in the sample.
- ▶ Stable, no-drift performance – performance verification is minimal.
- ▶ Long life light source – up to 10 years.
- ▶ Fixed trials have demonstrated the effectiveness of this analyzer on this application.
- ▶ No reagents or consumables (i.e. pump tubing) required – virtually no running costs.

What ABB Products are Suitable?

- ▶ 7320/1000 Complete System, which operates over the range 0 to 10 mg/l, with a minimum range of 0.2mg/l.

Associated ABB Products for use in Potable Water Treatment Plant

- ▶ Turbidity on raw water, after the clarifiers, after the filters and final water.
- ▶ pH control of the coagulation process.
- ▶ pH of raw water and of final water.
- ▶ Ammonia on raw water intake and on final water.
- ▶ Fluoride monitoring.
- ▶ Phosphate monitoring on final water.
- ▶ Nitrate monitoring of intake and final water.
- ▶ Flow measurement and recording.

Installation

- ▶ Avoid air bubbles by regulating the flow down stream of the monitor.
- ▶ Ensure the flow rate is within the limits stated in specification sheet.
- ▶ Ensure there is sufficient space to allow easy access to the wiper motor, the light source and the receiver.
- ▶ Ensure there is sufficient head room to make calibration a convenient procedure.

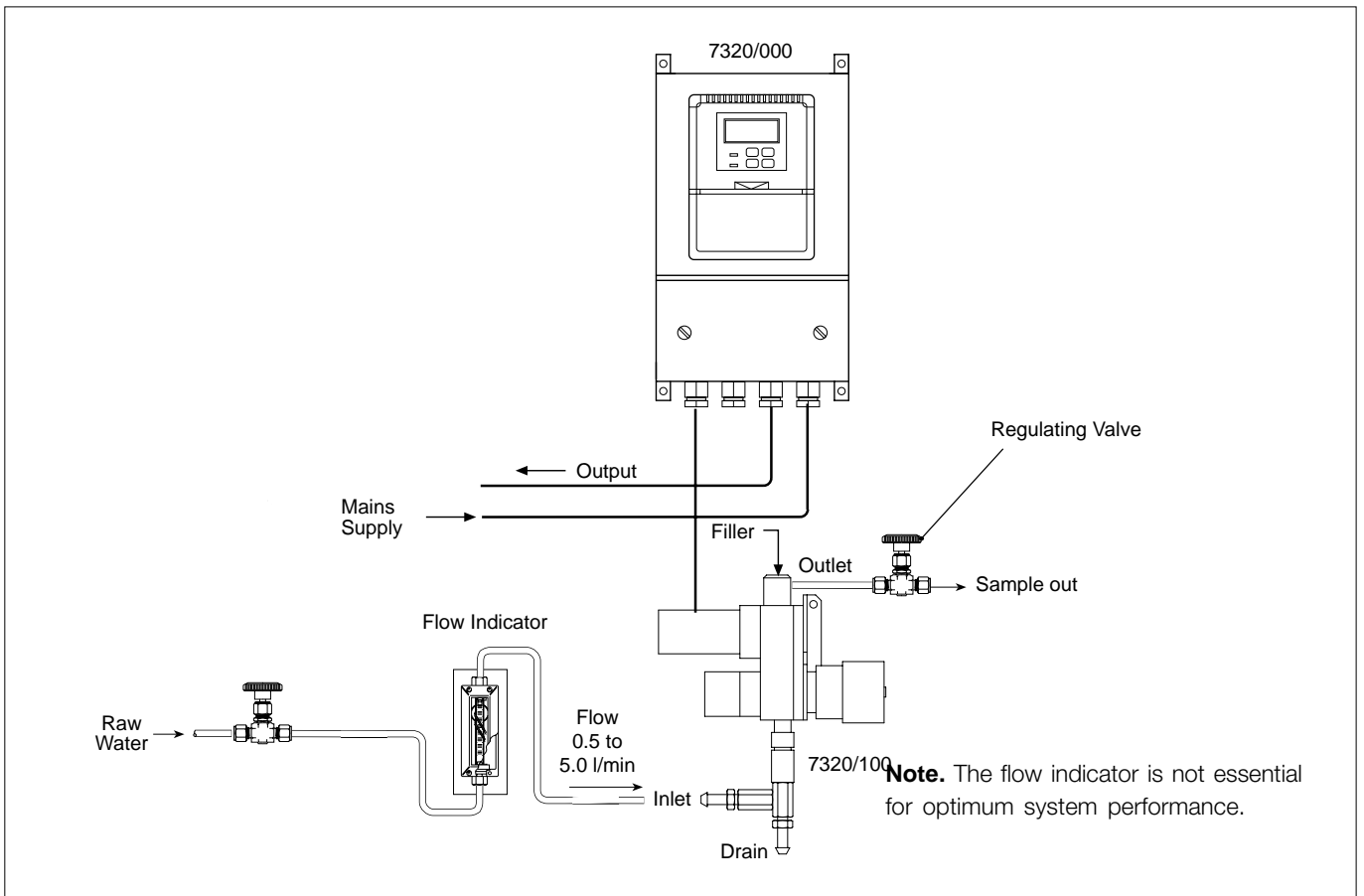

Comparison of Colour/UV Absorbtion

Graph showing analyzer results against laboratory T.O.C. analysis which demonstrates the strong and consistent relationship between the two measurements. By applying a coefficient factor it is possible to use the UV measurement as a cost effective surrogate measurement for T.O.C. where site conditions are suitable.



ABB has Sales & Customer Support
expertise in over 100 countries worldwide

www.abb.com

The Company's policy is one of continuous product
improvement and the right is reserved to modify the
information contained herein without notice.

Printed in UK (12.03)

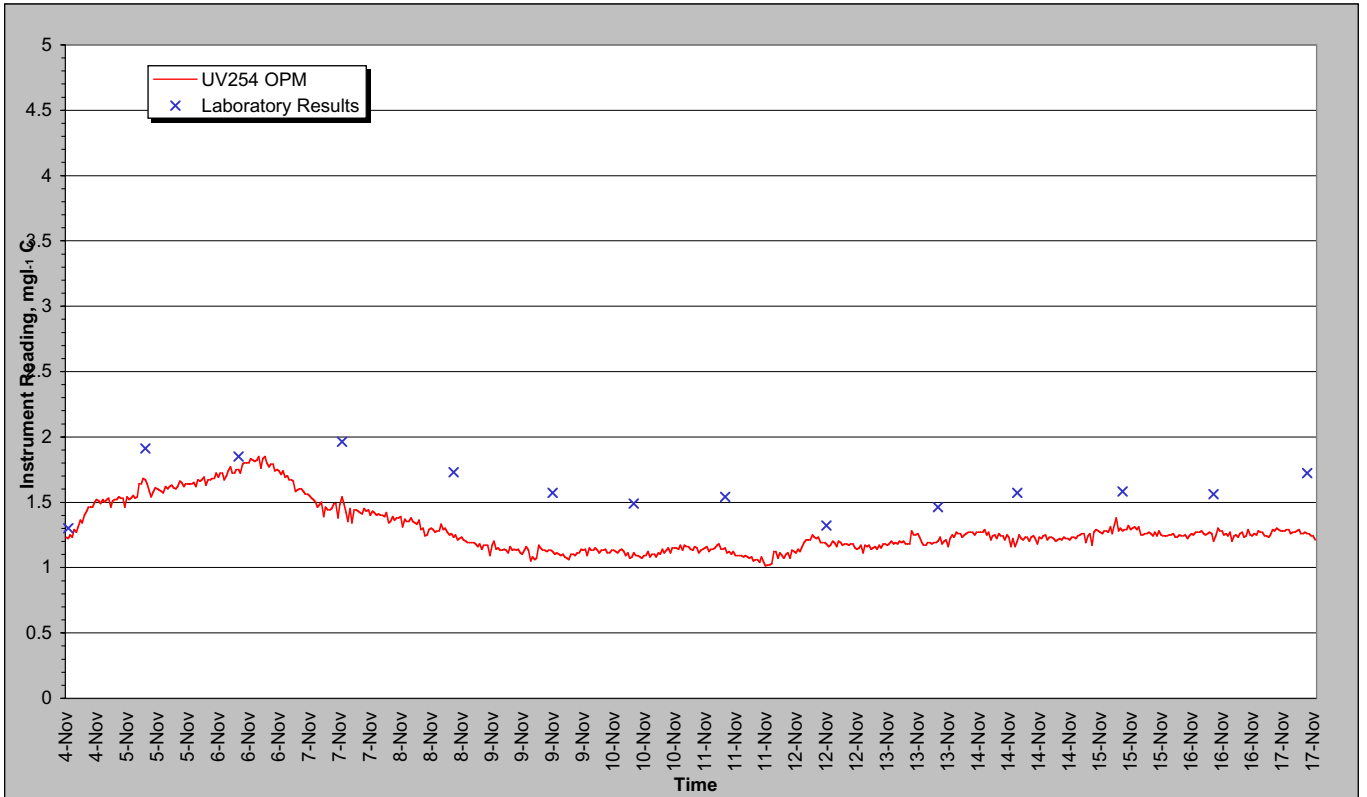
© ABB 2003



ABB Limited

Oldends Lane, Stonehouse
Gloucestershire
GL10 3TA
UK
Tel: +44 (0)1453 826661
Fax: +44 (0)1453 827856

ABB Inc.

125 E. County Line Road
Warminster
PA 18974
USA
Tel: +1 215 674 6000
Fax: +1 215 674 7183