







---

# 1 INTRODUCTION

---

## 1.1 General

The Model 8036 is a microprocessor controlled on-line monitor for measuring sodium in steam raising plant. Sampling points include mixed bed outlets in water treatment plants, extraction pump discharge, boiler feed, boiler drum and steam.

Two range groups are available:

- 0.01  $\mu\text{g kg}^{-1}$  to 1  $\text{mg kg}^{-1}$
- 0.1  $\mu\text{g kg}^{-1}$  to 10  $\text{mg kg}^{-1}$

with current output automatically switched to cover two decades within one group at any one time.

Two types of instrument are available: a  $\text{CE}$  approved version and a version without  $\text{CE}$  approval.

The  $\text{CE}$  approved version includes the addition of a user's terminal box on the side of the transmitter unit, containing electrical filtering on all inputs and outputs, and the mounting together of the sensor and transmitter as one unit.

The version without  $\text{CE}$  approval retains the facility of separating the sensor and transmitter units by a distance of up to 100 meters.

This manual covers both versions of the monitor, and where there are specific differences between the two, the  $\text{CE}$  approval mark is included in the drawings of the approved version.

## 1.2 Description

### 1.2.1 Sensor Units

The sensor units consist of a metal case which houses the liquid handling equipment. Pipework carrying the sample is mounted on a panel, bolted to the back of the unit with four M6 captive bolts.

The pre-amplifier and the container for the reagent are mounted on the sensor unit door. The junction box, convenient for the electrical connection of the electrode pair, is also mounted on the door.

The Liquid Handling Section contains a clear, acrylic flowcell where the sodium ion responsive electrode and the silver/chloride reference electrode measure the sample. The flowcell also houses a temperature sensor for temperature correction of electrode output.

The correct pH value of the sample is achieved by pretreating it with an alkaline vapour.

Calibration is carried out using standard solutions of a known value under the control of the transmitter unit.

A split drain tundish is provided to separate the clean drain from the contaminated drain.

### 1.2.2 Transmitter Units

The transmitter units consist of a metal case of similar construction to that of the sensor units with a chassis unit supporting circuit boards and other electrical sub-assemblies.

Microprocessor electronics control the functions of the transmitters, and the three main functions;

- a) interpret and display a reading of sodium received from the sensor unit,
- b) control the calibration sequence,
- c) provide various outputs to remote equipment.

Displays are three-digit, seven-segment light emitting diodes (l.e.ds) types showing the level of sodium and also giving operating mode information. They also show the operator when the instrument is in the calibration mode, and when the calibration has not been successful.

On the left hand side of the  $\text{CE}$  approved transmitter is a terminal box fitted with cable glands for the power input cable, the cable to the sensor unit and cables for alarm signals and other signal outputs. The terminal box lid is secured by six screws.

The transmitter unit, without  $\text{CE}$  approval, has a provided cable gland fitted to the gland plate on the left hand side of the case for the cable to the sensor unit. The gland plate is also drilled with five other holes which may be enlarged to accept customer's cable glands suitable for the cables carrying the alarm signals and other signal outputs. The maximum gland size is PG21.

## 2 INSTALLATION

### 2.1 Fixing of Units (Figs. 2.1 to 2.6)

#### 2.1.1 Location and Layout (Figs. 2.1 and 2.2)

Sensor and transmitter units should be mounted in a clean, vibration-free area, avoiding direct radiant heat, sunlight and drafts. Sites containing chlorination equipment should also be avoided.

Sensor units should be mounted not more than 10 meters from the associated sample cooler.

In the  $\text{CE}$  approved version (Fig. 2.1), the transmitter must be mounted immediately above the sensor unit and the two units must be interconnected by the supplied conduit.

The standard solution container is then mounted on a shelf (optional extra – Part No. 9390 742) alongside the transmitter, with the base of the container at the same level as the top of the sensor unit, and close enough to allow fitting of the quick release coupling tube between container and sensor unit.

The transmitter which is not  $\text{CE}$  approved may be mounted alongside or up to 100 meters away from the sensor unit. If the transmitter is to be mounted directly above the sensor unit, allow at least 250 mm separation between the units for access to the standard solution containers – see Fig. 2.2. Also allow sufficient space on the left hand side for connection of cables to the unit via the gland plate.

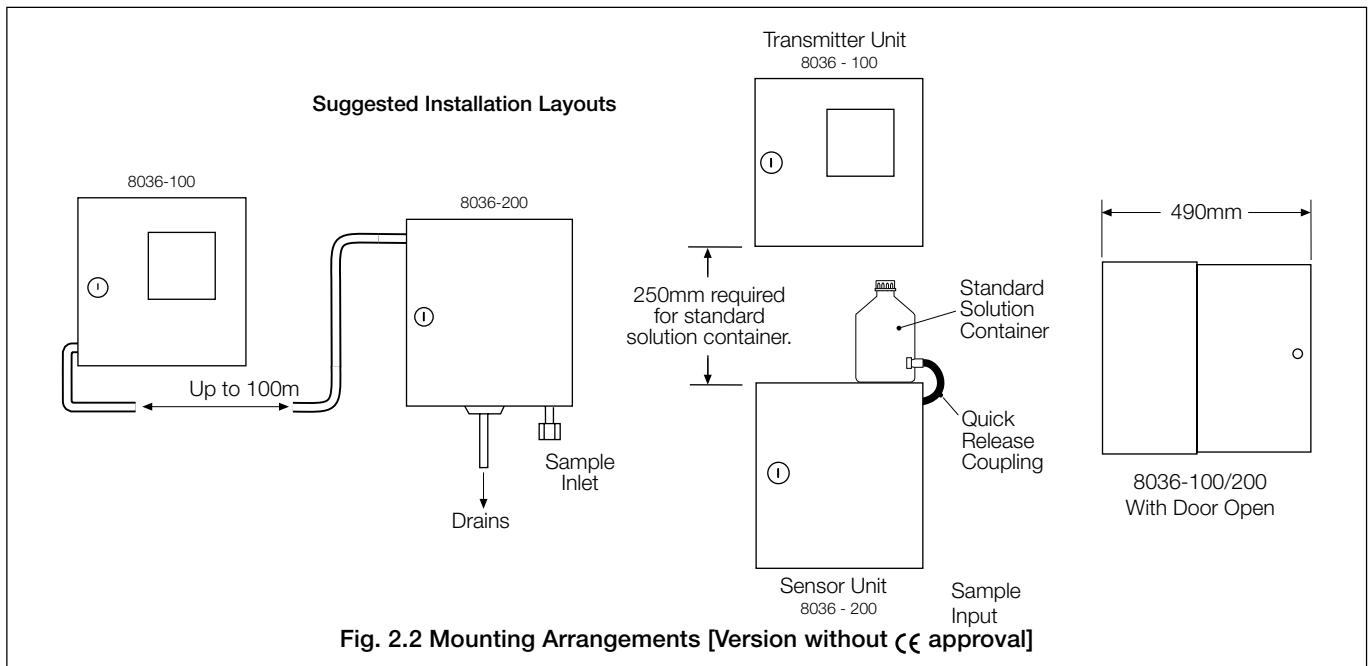
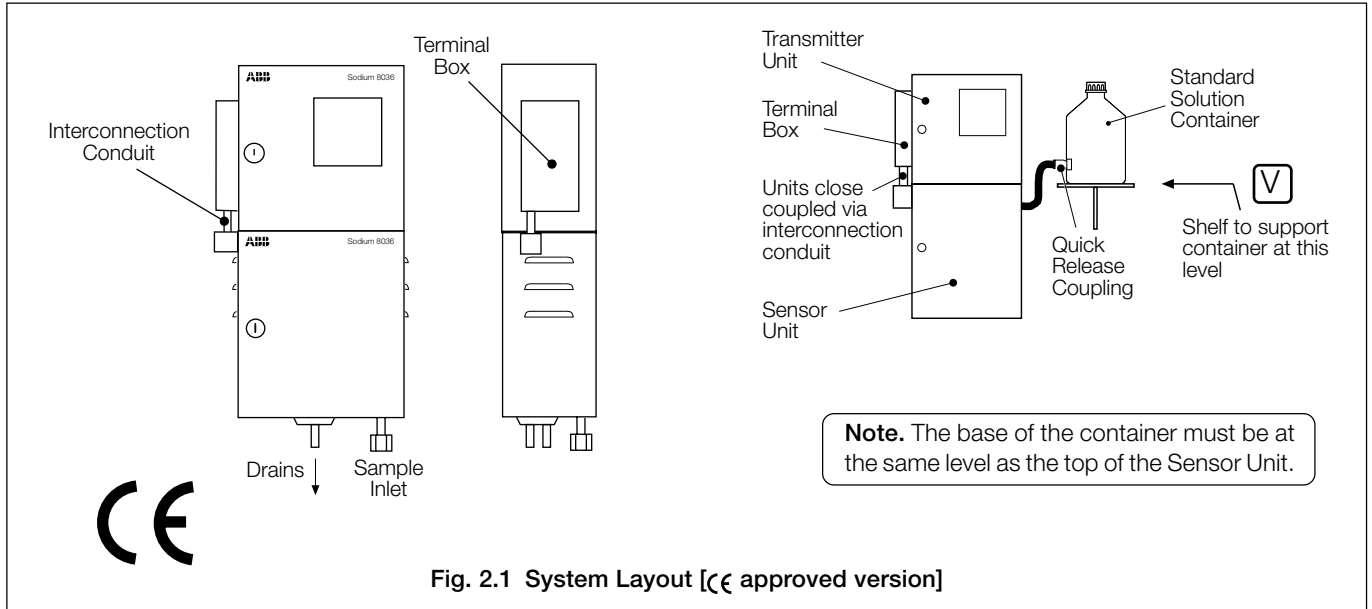

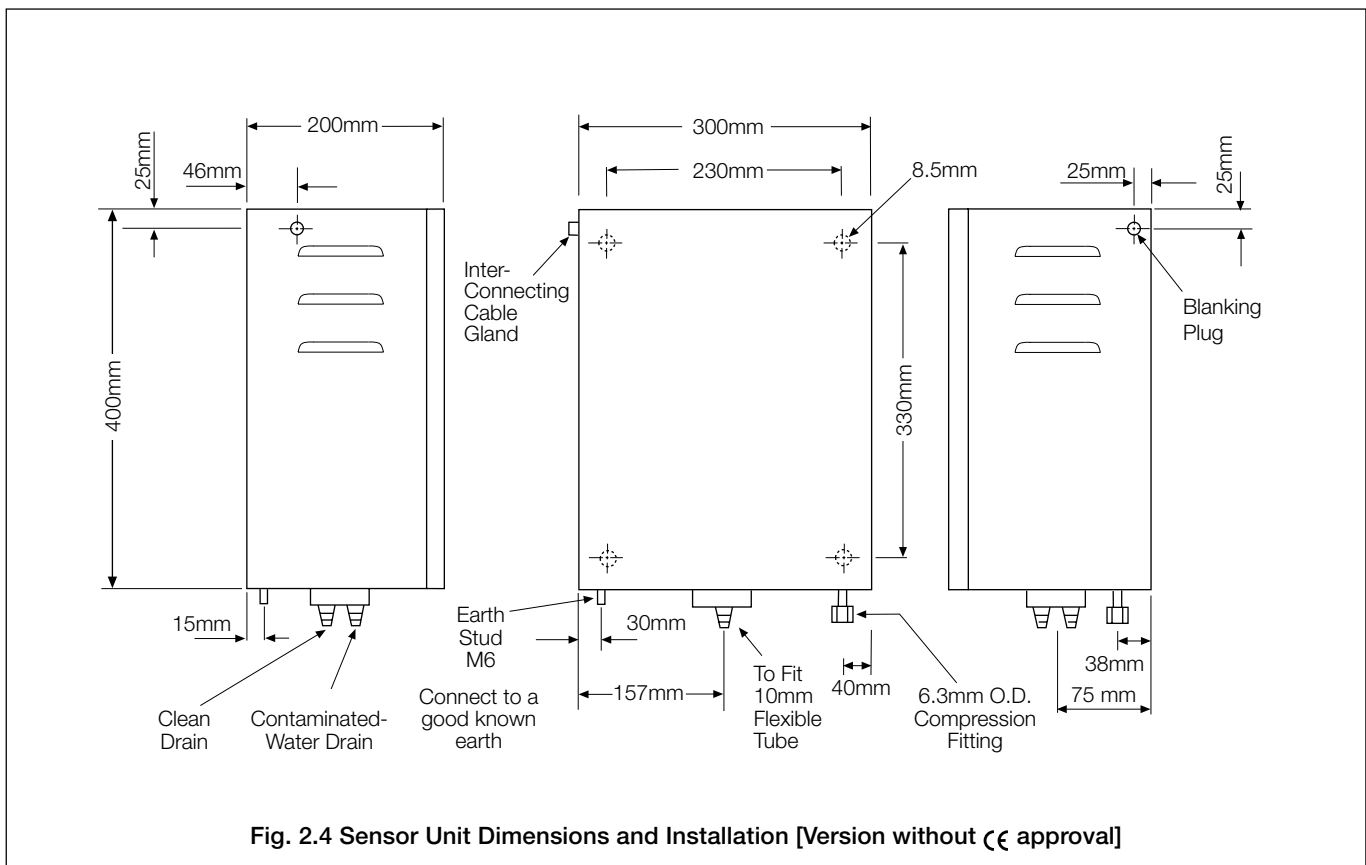
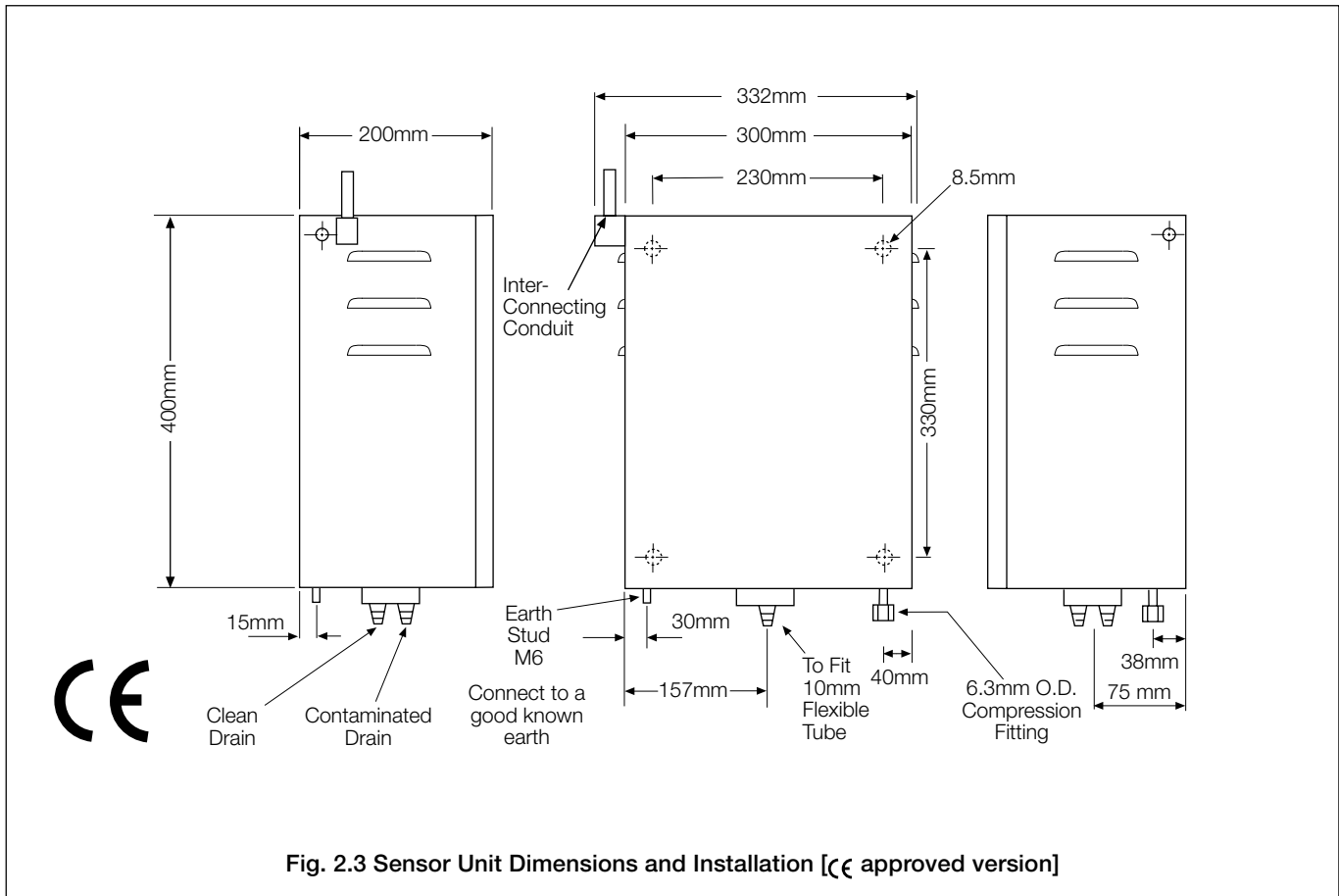

### 2.1.2 Sensor Units (Fig. 2.3 and 2.4)

Wall mounting is by four 8 mm diameter fasteners on 230 x 330 mm centres.

Refer to Fig. 2.1 for correct positioning of sensor and transmitter units. The  $\text{CE}$  approved transmitter unit mounted above the sensor unit, requires access to the terminal box on the left hand side, and sufficient space is required for the standard solution container on the right hand side. It is suggested that the sensor unit is mounted first, to allow the associated metal gland in the transmitter terminal box to be fitted over the interconnecting cable and conduit at the top of the sensor unit.

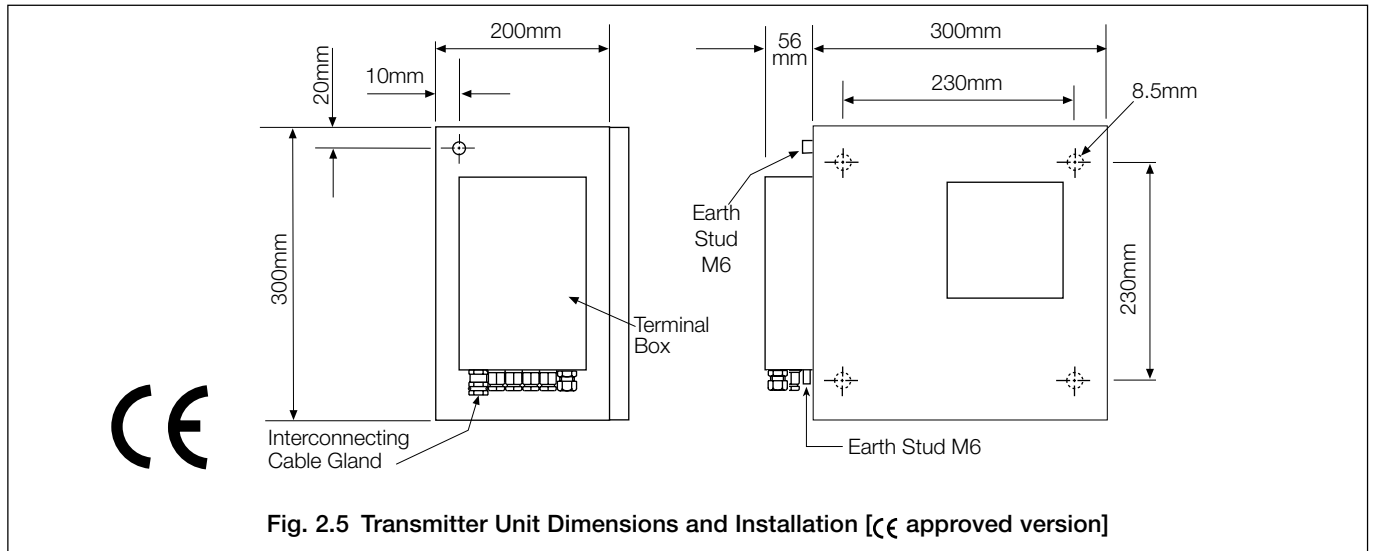

Fig. 2.5 Transmitter Unit Dimensions and Installation [ $\text{CE}$  approved version]

#### For access to wall mounting holes remove the chassis unit as follows:

- 1 Unlock the door and open it fully.
- 2 To release the escutcheon plate, remove all the 17 screws, and with a small coin or similar tool, turn the four black fasteners 1/4 turn in either direction.
- 3 Hold the front panel with two fingers through the slot at the left side. Ease the front panel forward over the Range Switch knob.
- 4 Remove the safety earth (ground) bonding leads attached to the metal case.
- 5 Release the captive screws securing the chassis assembly to the back of the case and remove the chassis.

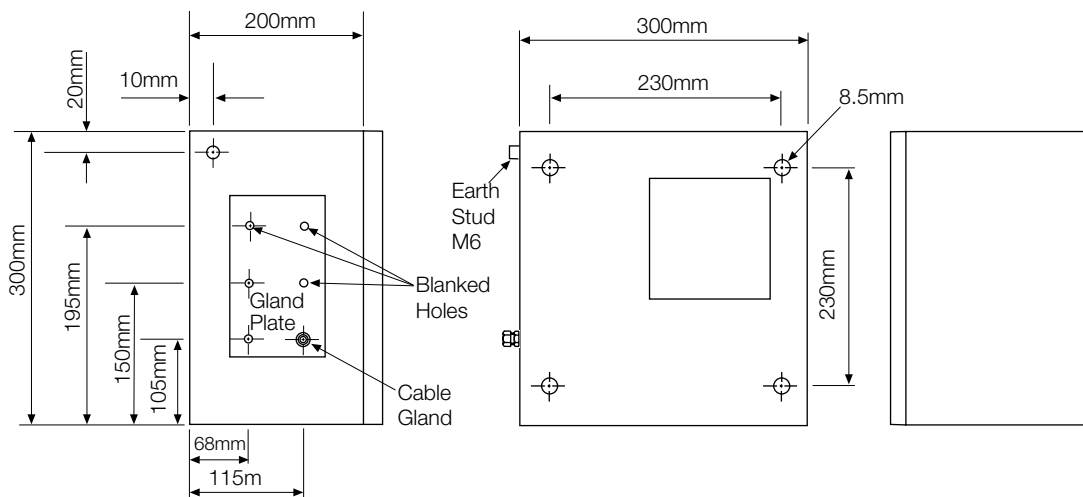
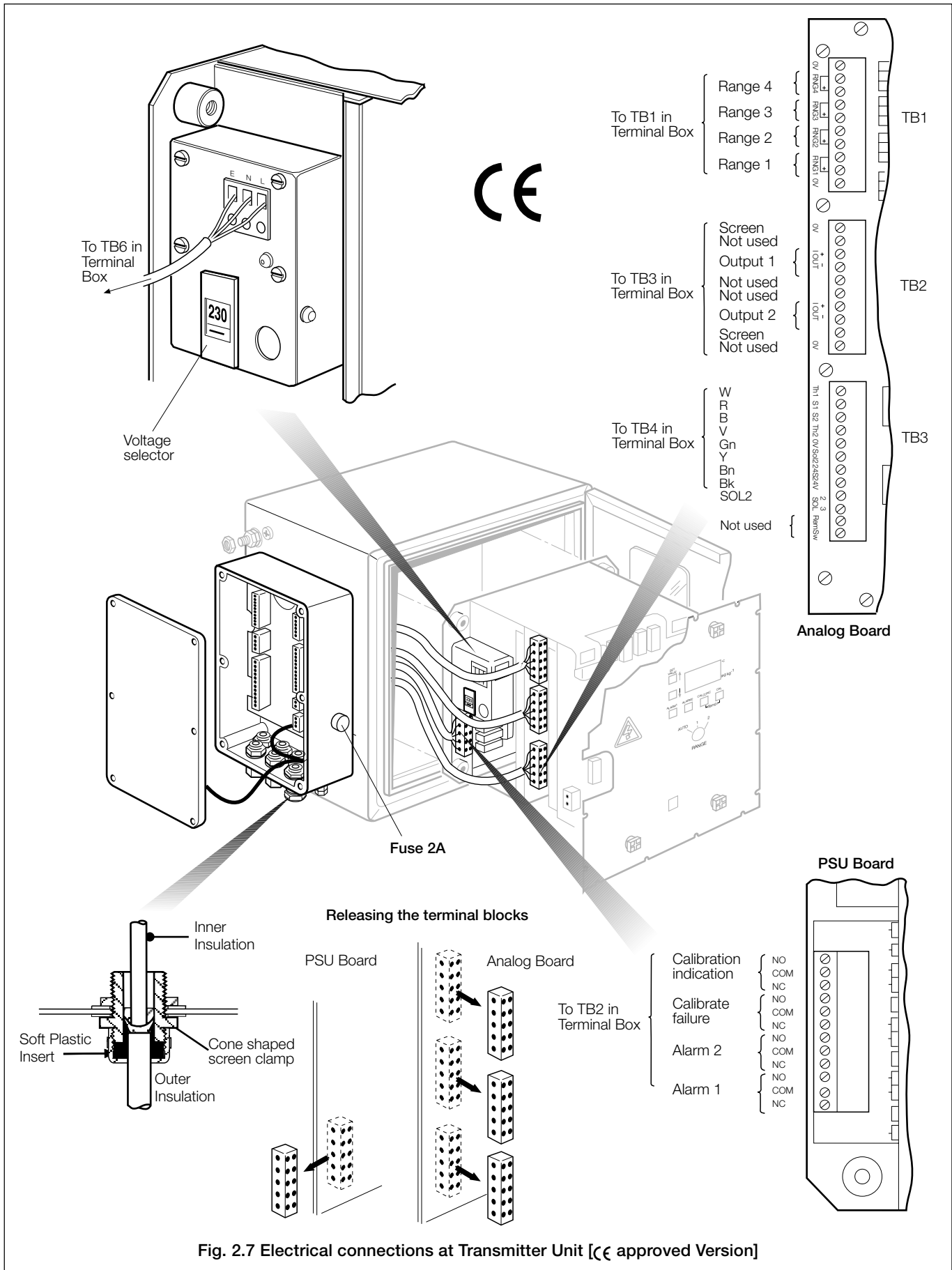

Fig. 2.6 Transmitter Unit Dimensions and Installation [Version without  $\text{CE}$  approval]



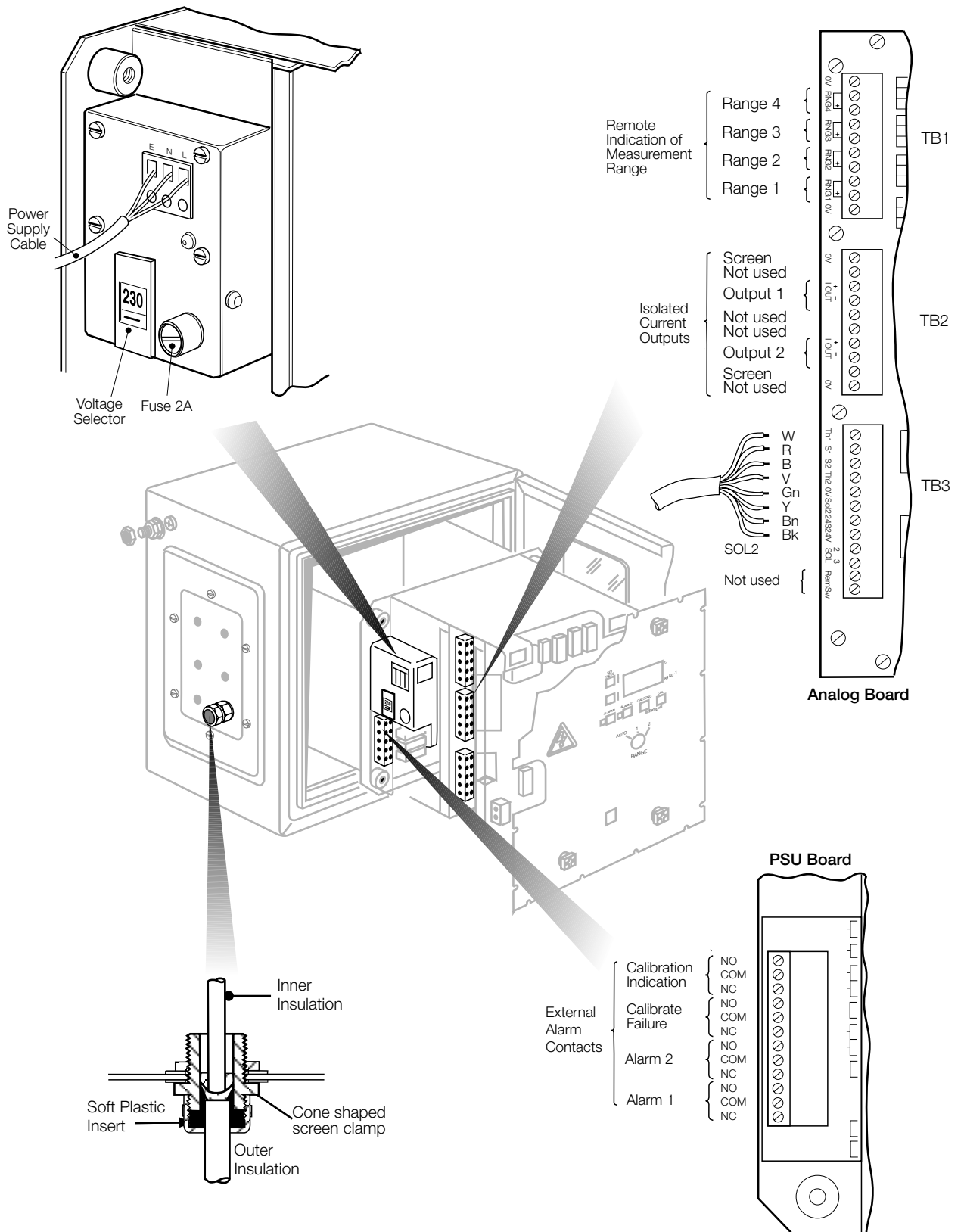

Fig. 2.8 Electrical connections at Transmitter Unit [Version without CE approval]

## ...2 INSTALLATION

### 2.1.3 Transmitter Units (Fig. 2.7 and 2.8)

Wall mounting is by four 8 mm diameter fasteners on 230 x 230 mm centres. Sufficient access space, as detailed previously, must be left for making cable connections to the transmitters and for the mounting of standard solution containers.

For access and fitting of the **CE** approved version, proceed as follows, and for the version without **CE** approval refer to the instructions in Fig. 2.6.

- a) Unlock the door and open it fully.
- b) To release the escutcheon plate remove all the 17 screws, and with a small coin or similar tool, turn the four plastic fasteners  $\frac{1}{4}$  turn in either direction.
- c) Hold the escutcheon plate with two fingers through the slot at the left side. Ease the escutcheon plate forward over the Range Switch knob.
- d) Remove the safety earth (ground) bonding leads attached to the metal case.
- e) Release the captive screws securing the chassis assembly to the back of the case and ease the chassis forwards.
- f) After recording the position of the connection blocks on the circuit boards – see Fig. 2.7, remove the connection blocks from the analog board by applying force outwards from the face of the analog board. To remove the connector from the PSU board, slide the connector sideways towards the vertical edge of the board.
- g) Loosen the associated screws to release the three wires from the mains input connector on the PSU Board – see Fig. 2.7.
- h) Remove the chassis.
- i) To position the transmitter unit above the sensor unit, loosen the two screws in the metal gland in the transmitter terminal box. Feed the sensor cable through the gland and the metal conduit into the gland. The conduit is secured at the sensor unit with two grub screws, which should be loosened, to aid the alignment of transmitter and sensor units.
- j) With the two units fixed in position, secure the interconnection cable with the gland clamp nut **before** securing the conduit by tightening the two screws on the gland and the two grub screws at the sensor unit.

**Note.** Before fitting the chassis unit, check that the voltage selector is set to the correct value before connecting the unit to the supply, and refer to Section 2.6 for procedures required before Start-up.

**Caution.** When replacing the connection blocks, care should be taken to ensure that the blocks are aligned correctly to cover all the associated connecting pins.

k) With the transmitter case secured to a wall or panel, offer the chassis to the case and wire the mains connection. Fit the connection blocks onto the circuit boards.

l) Fit the chassis unit, secure it with the captive screws and replace the earth (ground) bonding leads.

m) Position the escutcheon plate and secure it with the four plastic fasteners. Fit all 17 screws.

## 2.2 Sample Requirements

**Warning.** The maximum pressures and temperatures specified must not be exceeded.

Where pressure reducing equipment is being used it is recommended, for safety reasons, that a pressure relief valve should be installed between this and the sample inlet to the monitor.

The sample should be brought to the temperature and pressure suitable for measurement (see Section 7) using sample coolers and pressure reducing equipment.

## 2.3 External Pipe Connections

### 2.3.1 Inlet

The sample should be connected to the sensor unit using 6.3 mm ( $\frac{1}{4}$  in) o.d. tubing (stainless steel or rigid plastic). Connect this to the sample inlet coupling on the right-hand side of the bottom of the case.

The inlet tubing should be of sufficient wall thickness to withstand the highest sample pressure, and pipe lengths should be kept short.

Where particulate matter is present (e.g. magnetite in boiler samples) it is recommended that a 60 micron sample filter is fitted to the sample line.

A shut-off valve (not supplied with the equipment) is necessary in the sample inlet.

### 2.3.2 Drain

The drain from the tundish at the bottom of the sensor unit case consists of two stub pipe connections suitable for 10 mm ( $\frac{3}{8}$  in) bore plastic or rubber tubing. Alkaline effluent from the monitor flow cell appears at one connection and waste sample from the other.

The two connections can either be linked by a 'Y' piece and taken to a contaminated drain, or they can be kept separate and led to appropriate drains.

## 2.4 Electrical Interconnections

### Warning.

- Although certain instruments are fitted with internal fuse protection, a suitably rated external protection device, e.g. fuse or miniature circuit breaker (m.c.b.), must also be fitted by the installer.
- Before making any connections, ensure that the power supply and high voltage power-operated control circuits are switched off.
- This equipment operates on a.c. mains supply voltage electricity. Suitable safety precautions must always be taken to avoid the possibility of an electric shock.

### 2.4.1 Sensor Units

The 8-way cable connecting the sensor unit to the transmitter unit is preformed and is supplied already connected to the sensor unit. This avoids the need to open the pre-amplifier box which could admit moisture, and because of the very high source impedance of the sodium electrode (up to 5000 Mohm, at sample temperature of 5 °C), would affect the instrument's performance.

For units without  $\text{CE}$  approval, distances up to 100 meters between the sensor unit and transmitter unit are possible. The cable is extended using a junction box mounted adjacent to the sensor unit and the required length of 8-way cable.

**Note.** A stud terminal is fitted to the bottom of the sensor unit case and must be connected to a good known earth (ground).

### 2.4.2 The $\text{CE}$ Approved Transmitter

To gain access to make the necessary connections, if not already done, remove the six screws from the terminal box on the side of the transmitter and remove the lid. Then:

- Prepare the cable from the sensor unit to terminate it on terminal block TB4 inside the terminal box. Connect the screen of the cable to the internal earthing (ground) point at the bottom of the terminal box.
- Pass the cables, necessary for the supply, output signals, alarms and remote function, through the plastic glands and connect the cables as follows – see also Fig. 2.9:

#### Range relays (TB1)

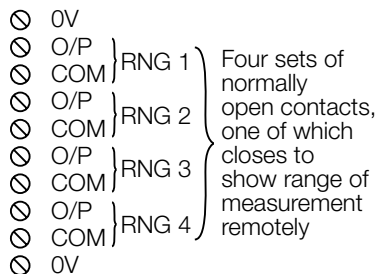

See Section 2.5 for further details regarding the wiring of the above connector.

#### Alarm relays (TB2)

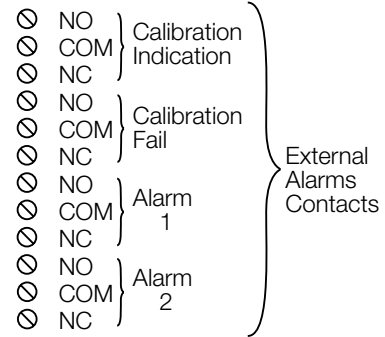

#### Current outputs (TB3)

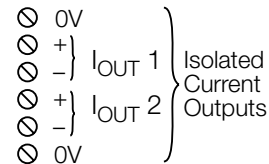

#### Sensor unit (TB4)

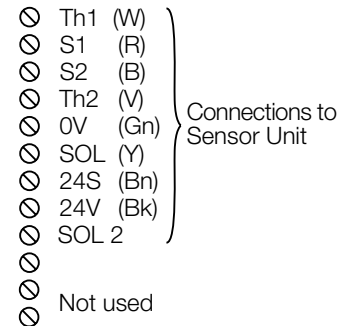

#### (TB5)



#### Power supply (TB6)

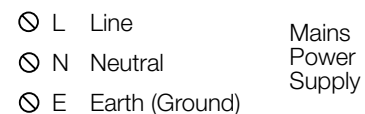

#### (TB7)



#### Chassis

**Warning.** The power supply earth (ground) must be connected to ensure safety to users, reduction of the effects of RF interference, and correct operation of the power supply interference filter.

A voltage selector is located on the chassis unit. This voltage selector must be set to the correct value before connecting the instrument to the supply – see Fig. 2.7.

Tidy the cables in the terminal box and fit and secure the terminal box lid. Tighten the gland nuts.

## ...2 INSTALLATION

### 2.4.3 Transmitter Unit (Fig. 2.8)

For the  $\text{CE}$  approved version transmitter, see Section 2.4.2.

To gain access to make the necessary connections, proceed as follows:

- Remove the six screws securing the gland plate to the left-hand side of the transmitter case. Fit suitable cable glands to the plate, to take the cables necessary for the supply, output signals, alarms and remote function, if used.
- Open the transmitter door and remove the escutcheon plate – see Section 2.1.3, paragraphs a,b and c.
- Cut the cable from the sensor unit to a length to reach the transmitter easily to terminate on terminal block TB3 on the analog board.
- Push the end of the cable through the supplied gland in the gland plate.
- Noting that the screening braid terminates at the cable gland and is prepared as shown in Fig. 2.8, prepare the cable end and attach it to the terminal block TB3. The terminal block may be pulled off the pins on the board if required.

**Caution.** The terminal block for sensor unit connection has eight terminals, whereas there are 12 pins on the board. Ensure that the correct eight pins are chosen for connection; these are marked, on the PCB, with a separate 'box' – see the following text and Fig. 2.8.

Pass the remaining cables through the glands. Note that Pin 1 of each block is nearest the top of the case. Prepare the cable ends and attach them to the terminal blocks as follows – see also Fig. 2.8.

Digital board (nearest front panel - no terminations).

#### Analog board TB1 (top edge):

PIN	1	0V		
	2	NO	} R4	Four sets of normally open contacts, one of which closes to show range of measurement remotely.
	3	COM		
	4	NO	} R3	
	5	COM		
	6	NO	} R2	
	7	COM		
	8	NO	} R1	
	9	COM		
	10	0V		

See Section 2.5 for further details regarding the wiring of the above connector.

#### Analog board TB2 (middle):

PIN	1	0V	} Isolated current outputs
	2	Not used	
	3	+	
	4	-	
	5	Not used	
	6	Not used	
	7	+	
	8	-	
	9	Not used	
	10	0V	

#### Analog board TB3 (bottom edge):

PIN	1		} Connections to sensor unit
	2	+	
	3	-	
	4		
	5	0V	
	6	Solenoid valve	
	7	24V sense	
	8	24V	
	9	Not used	
	10	Not used	
	11	Not used	
	12	Not used	

#### PSU board TB3:

PIN	1	NO	} External alarm contacts
	2	COM	
	3	NC	
	4	NO	
	5	COM	
	6	NC	
	7	NO	
	8	COM	
	9	NC	
	10	NO	
	11	COM	
	12	NC	

#### Chassis

**Warning.** The power supply earth (ground) must be connected to ensure safety to users, reduction of the effects of RF interference, and correct operation of the power supply interference filter.

A voltage selector is located next to the supply terminals. This voltage selector must be set to the correct value before connecting the instrument to the supply – see Fig. 2.8.

Tidy the cables in the gland plate and fit the gland plate to the transmitter. Tighten the gland nuts.

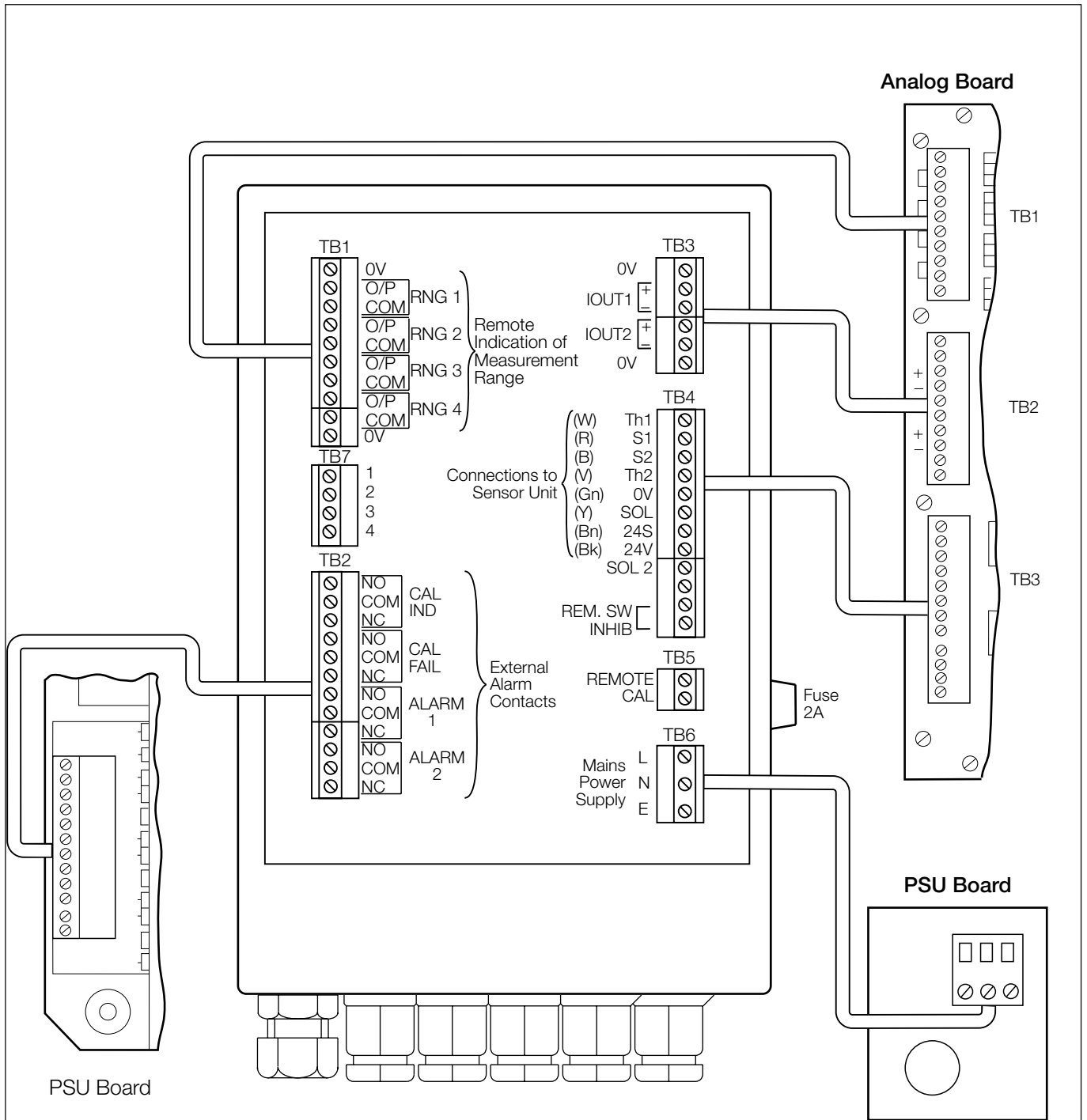

PSU Board

PSU Board



**Note.** A stud terminal is fitted to the bottom of the transmitter unit case and must be connected to a good known earth (ground).

Fig. 2.9 Electrical Connections at Transmitter Unit [CE approved Version]

## 2.5 Ancillary Equipment

### 2.5.1 Recorders

The choice of two different isolated recorder output signals enables the instrument to be used with a wide variety of recording and data processing equipment. The load requirements are shown in Section 7, and the positions of the circuit board switches are given in Section 3.2.3.

### 2.5.2 Range Indication

The remote range indication relays (TBI connections) can be used in several different arrangements to suit the requirements of the installation. The relays can, for example, be wired directly into the PLC or data logger, but if a recorder is used, a method of indicating the set range is required. A 2 pen recorder is necessary; pen 1 indicating the sodium concentration as above, and pen 2 recording the instrument range.

Suitable range indication recorder input can be achieved using a resistor network, connected as shown in the two examples in Fig. 2.10. and consists of four  $\frac{1}{4}$  watt resistors. A suitable resistor network kit is listed in Section 6. A recorder with suitable voltage and resistance inputs can be provided by the Company. The recorder gives 60, 70, 80 and 90% scale deflection for ranges 1 to 4 respectively.

Other arrangements should be designed to suit the requirements of the system.

Ensure that all external equipment is set up and working according to the relevant instructions supplied with it.

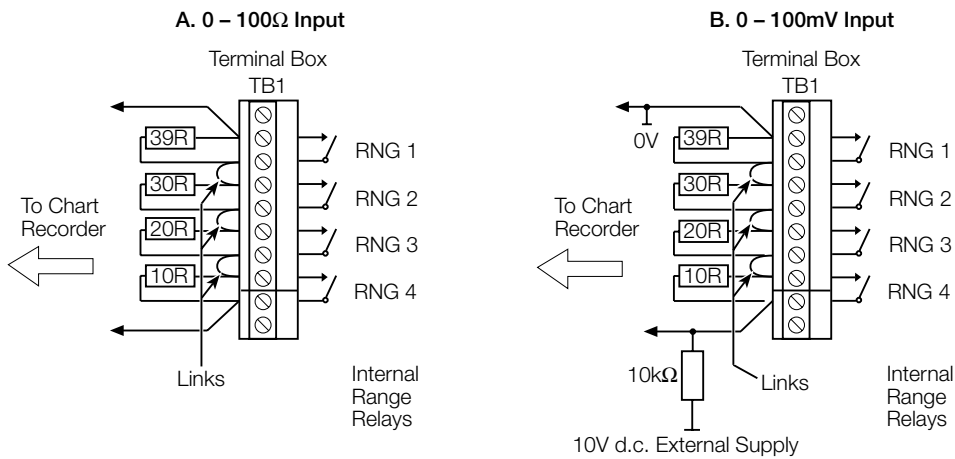

Fig. 2.10 Resistor Network for 'Auto' Remote Range Indication Recorder [ $\zeta\zeta$  approved version]

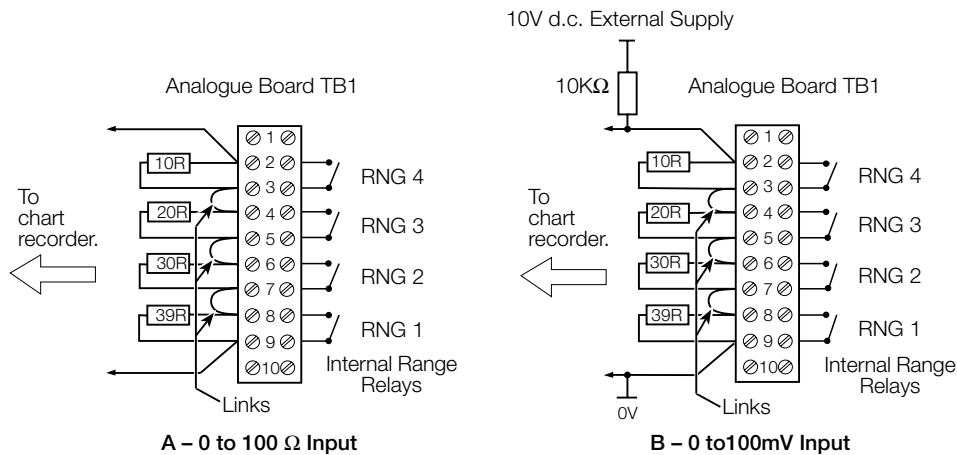
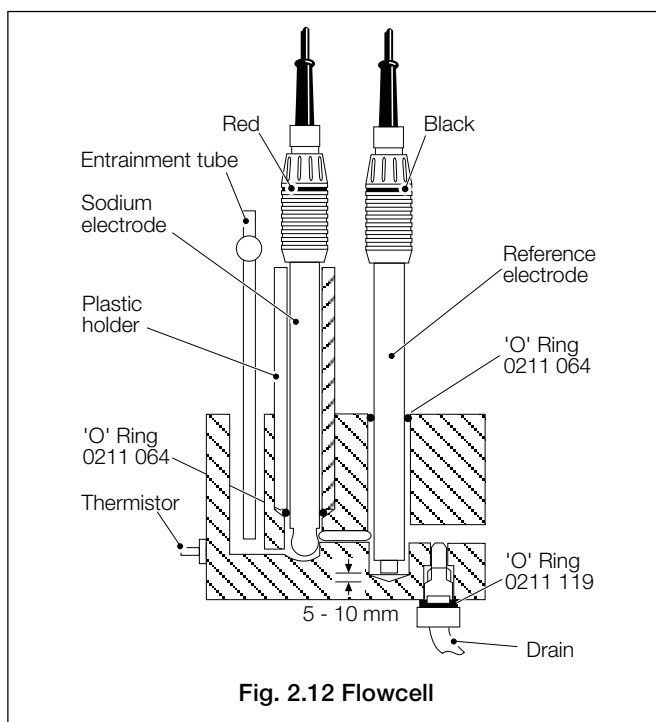

Fig. 2.11 Resistor Network for 'Auto' Remote Range Indication Recorder [Version without  $\zeta\zeta$  approval]

### 2.6 Start-Up (Figs. 2.11, 2.12 and 3.5)

- a) Open the transmitter unit door and remove the escutcheon plate if this has not already been done – see Section 2.1.3.
- b) Set the battery switch, SW10, to ON – see Fig. 3.5.
- c) Replace the escutcheon plate and secure with the plastic fasteners and 17 screws.
- d) Power up the monitor at the external source and set the Range Switch to AUTO.
- e) Unpack the sodium electrode and carefully remove the rubber teat. Remove the cylindrical plastic holder from the central chamber – see Fig. 2.11, and slide the electrode fully into the holder. Carefully screw the holder, with electrode, into the centre chamber of the flow cell so that the electrode bulb passes through the 'O' ring, and position the electrode so that when the plastic holder is tightened against the 'O' ring, the bulb of the electrode is just above the bottom of the chamber. Connect the red connector to the electrode (see Fig. 2.9).
- f) Unpack the reference electrode and remove the rubber teat. Release the black rubber filling hole plug. Remove the supplied 'O' ring (temporarily secured to the top of the right-hand chamber), and fit the 'O' ring over the electrode body. Carefully position the electrode centrally in the right-hand chamber of the flowcell so that the ceramic plug is between 5 and 10 mm from the bottom of the chamber. Connect the black connector to the electrode (see Fig. 2.11).
- g) Fill the reagent solution container with appropriate solution – see Section 5.1 .
- h) Open the shut-off valve upstream of the sensor unit and adjust it until sample is overflowing from the constant head unit. The maximum and minimum flow rates are given in Section 7.
- i) Leave for at least one hour.
- j) Set up the transmitter as described in Section 3.2.3.
- k) Carry out a calibration as detailed in Section 4.
- l) The monitor is now in operation. The lamp adjacent to the marked unit of measurement being illuminated.
- m) If required, turn the range switch to one of the non-auto ranges.
- n) Press the ALARM 1 button and use the UP/DOWN buttons to set to the desired value. Repeat for ALARM 2.



**Note.** It is extremely important that the 'O' rings are correctly fitted and that the inside of the electrode connectors are dry and completely sealed. Moisture reduces the circuit impedance and affects the performance of the monitor.

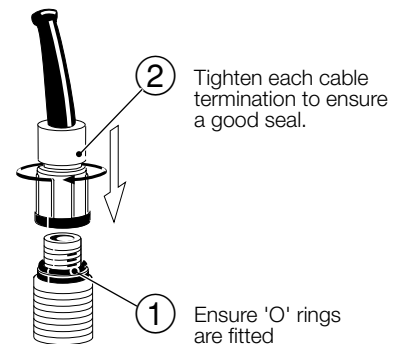

### 3 PRINCIPLE OF OPERATION

#### 3.1 Sensor Units (Fig. 3.1 and 3.2)

A flow schematic is shown in Fig. 3.1 and the physical layout of the unit is shown in Fig. 3.2.

The sample enters via a compression fitting at the bottom of the case and passes through one half of a heat exchanger which is used during the calibration sequence to bring the standard solution close to the temperature of the sample. This minimizes the calibration time.

From the heat exchanger the sample passes through a solenoid valve to the constant head unit which removes the effect of changes in sample pressure and flow-rate. A small tube overflowing into the constant head on one side, ensures self starting when the sample is lost, and enables the monitor to function over a wide sample flow.

The sample is then delivered to the 'T' piece and stainless steel entrainment tube, where an alkaline vapour reagent is added to the sample to raise the pH value, before flowing past the sodium and reference electrodes mounted in the flowcell. The sample leaves the flowcell and is passed to the drain at the bottom of the case.

The potential developed between the sodium ion-responsive electrode and silver/silver chloride reference electrode is logarithmic with respect to changes in sodium ion concentration. The signal from the electrode pair is connected

via a junction box to a voltage-to-current pre-amplifier whose output is connected to the transmitter unit via the interconnection cable.

A temperature sensor, fitted into the flowcell, detects the temperature of the sample. The sensor is connected to the transmitter unit which compensates for changes in output from the electrode pair over a range of 5 to 55 °C.

Calibration of the monitor is controlled by the microprocessor. After connection of the calibration tube to the standard solution container, the appropriate button on the transmitter unit is pressed. The solenoid valve on the liquid handling panel is energized changing over from sample to standard solution which first passes through the second half of the heat exchanger. The solution is presented to the electrode pair via the constant head unit and the vapour entrainment tube.

The solenoid valve is closed to the sample during a calibration sequence, but under sample pressure the pressure relief valve opens allowing sample to pass through the heat exchanger thus bringing the standard solution to a similar value to that of the sample.

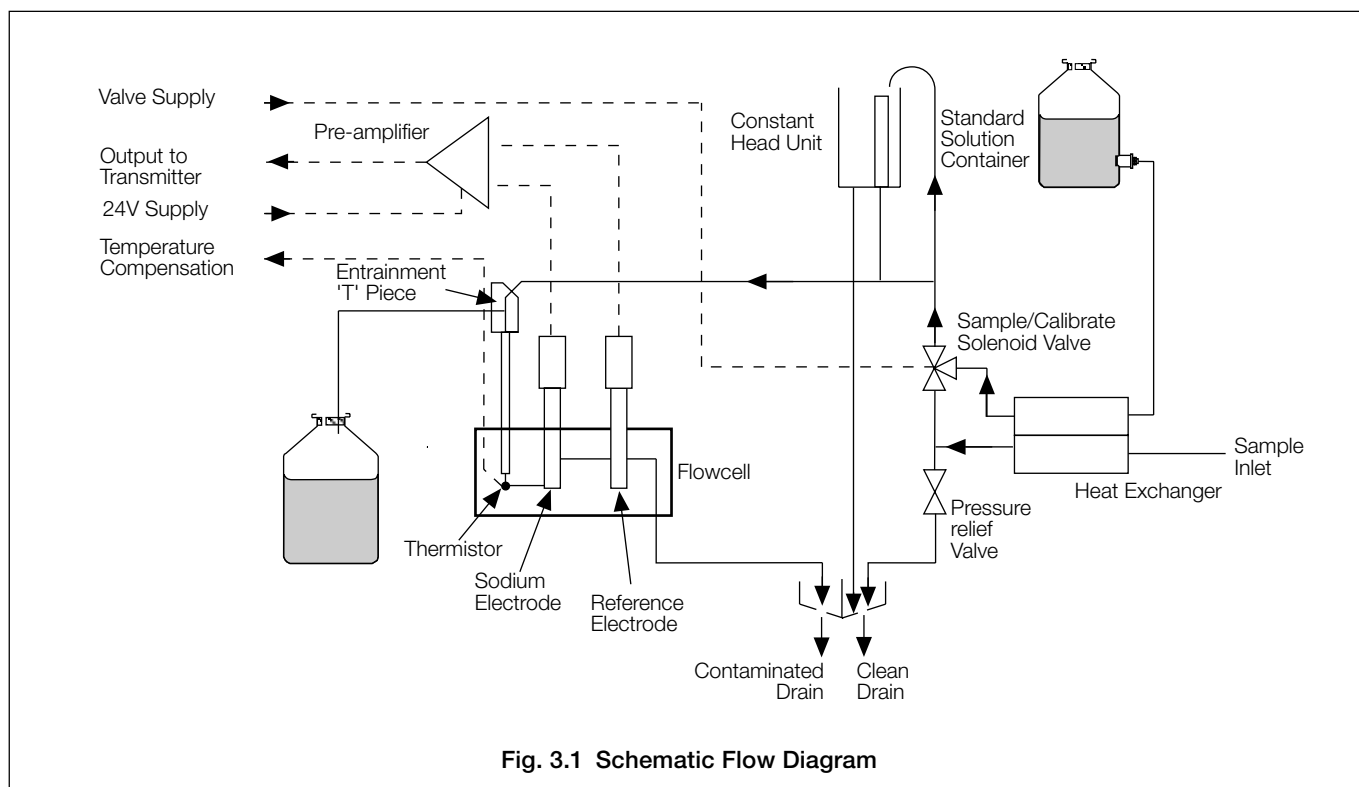

Fig. 3.1 Schematic Flow Diagram

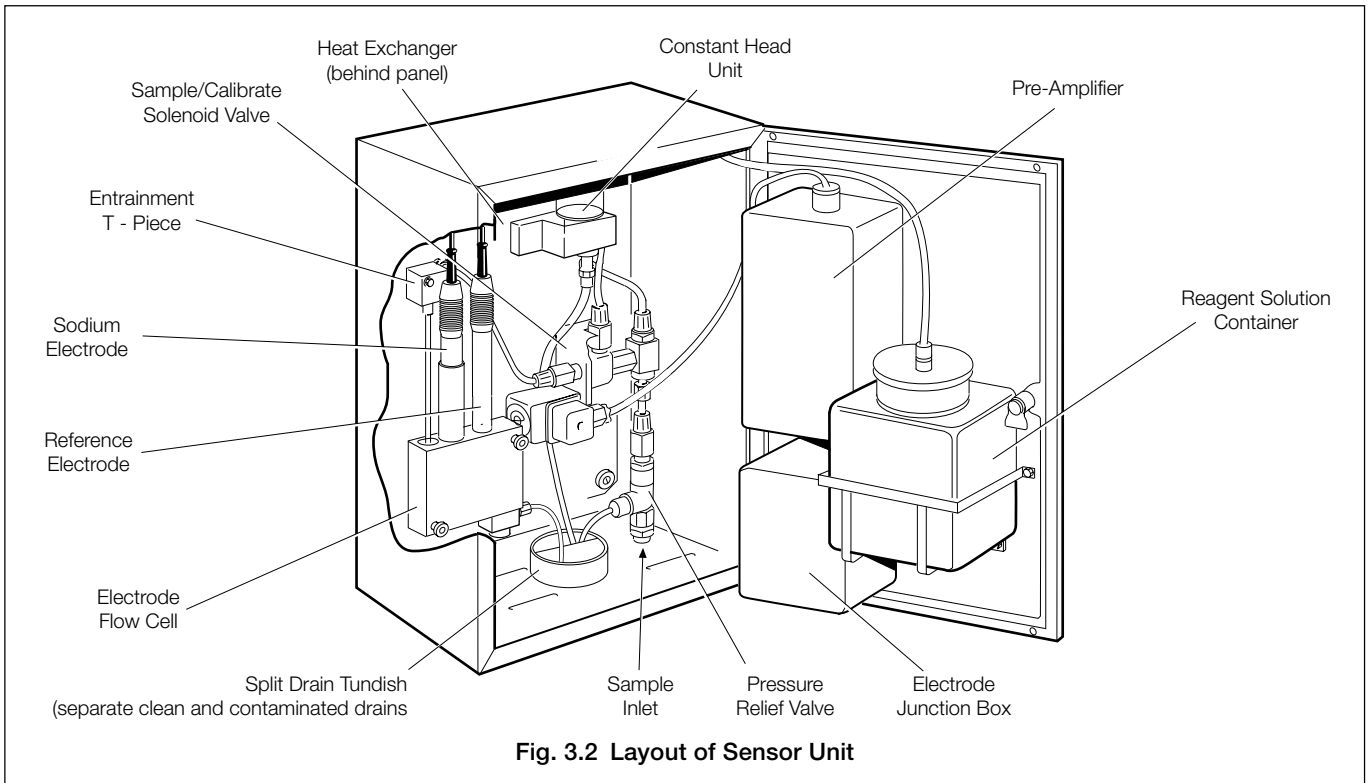

Fig. 3.2 Layout of Sensor Unit

### 3.2 Transmitter Units (Fig. 3.3)

#### 3.2.1 Electronics Chassis

The chassis contains three circuit boards:

- Digital board –** Behind the escutcheon plate, containing the central processor unit, front panel controls and the display.
- Analog board –** Middle board, containing the analog input and current output circuitry.
- PSU board –** Rear board, containing the power supply and output relays.

#### 3.2.2 Front Panel Controls (Fig. 3.4)

The controls are mounted on the front circuit board in the chassis and protrude through holes in the escutcheon plate. The chassis is secured to the escutcheon plate by four plastic fasteners, and the escutcheon plate is secured to the transmitter container with screws.

A 3-digit red l.e.d. display shows the sodium level in milligrams or micrograms per kilogram, the range being indicated by a lamp in the display adjacent to the relevant legend on the panel. The controls have the following functions:

- RANGE switch** (5 Position) ①  
Positions 1, 2, 3 and 4 are the manual ranges within the 5 decade preset range selected on SW1, – see Section 3.2.3. Position 5, AUTO, automatically switches to a range suitable for the sodium level being measured within the overall preset range. Remote range indication is provided.
- SET VALUE:** ②  
These buttons (UP/DOWN arrows) increase or decrease the value displayed on the digital indicator; used for setting the alarms and standard solution values.
- CAL 1:** ③  
When the button is pressed a primary calibration sequence is initiated. Pressing CAL1 during a calibration for at least five seconds cancels the sequence.
- CAL 2:** ④  
When the button is pressed a secondary calibration sequence is initiated. Pressing CAL2 during a calibration for at least five seconds cancels the sequence.

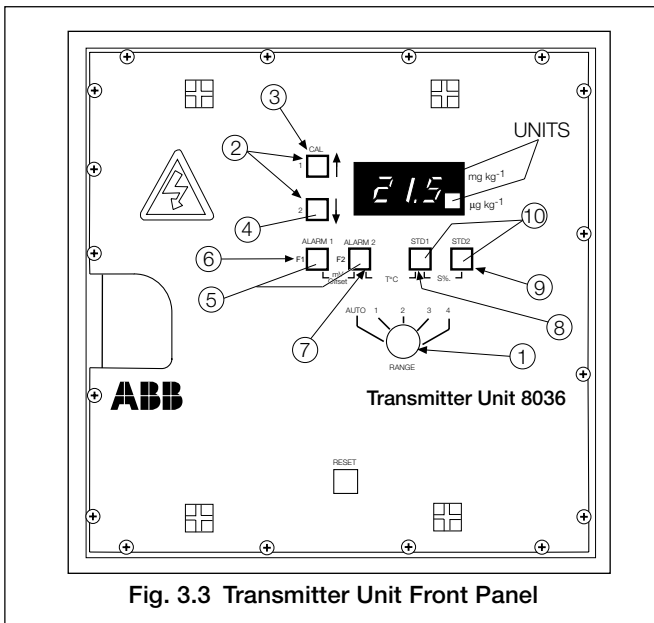

Fig. 3.3 Transmitter Unit Front Panel

### ...3 PRINCIPLE OF OPERATION

**Alarm 1/Alarm 2:** ⑤

Used in conjunction with the UP/DOWN buttons to set the values at which the alarm relays operate.

**F1:** ⑥

Pressing this button during a calibration sequence, displays the output from the sodium electrode.

**F2:** ⑦

Holding this button while pressing and releasing RESET defaults the calibration slope value to 100% and the zero offset to zero.

**mV Offset:**

Pressing F1 and F2 together gives the offset (in mV) generated by the electrode at the last calibration.

**STD1:** ⑧

Used in conjunction with the UP/DOWN

**STD2:** ⑨

buttons to set the values of the standard solutions into the instrument.

**S%:** ⑩

Pressing STD1 and STD2 together gives an indication of the electrode % slope value, which was calculated during the last TWO POINT CALIBRATION.

**Temp.**

Pressing F2 and STD1 together displays the temperature (in °C) of the solution in the flow cell.

**RESET:**

Used to regain control of the instrument in the unlikely event of a malfunction due to high supply transient, etc. (This button is not visible when the cabinet door is closed.)

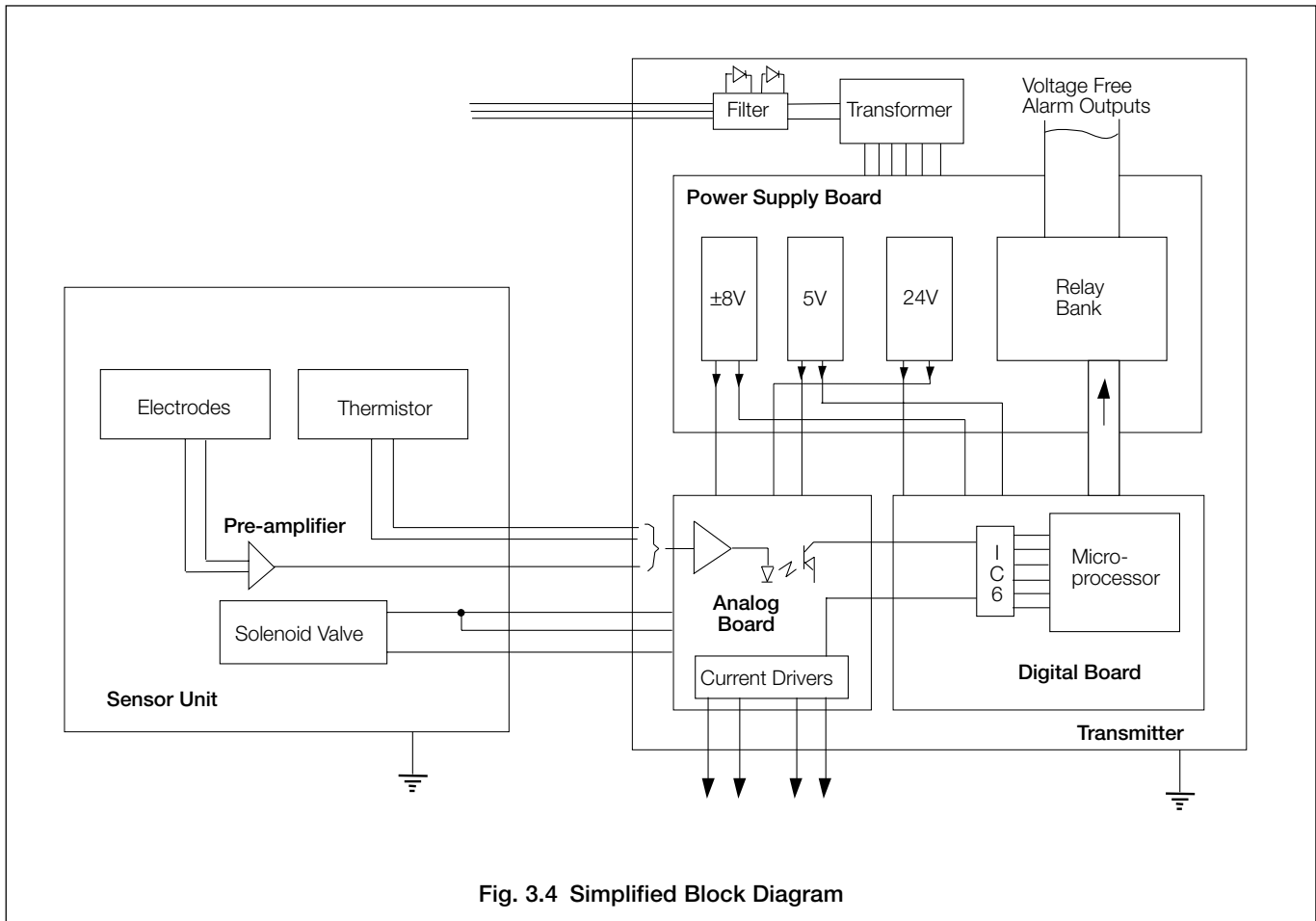

**3.2.3 Circuit Board Function Switch SW1 (Fig. 3.5)**

A series of eight ON/OFF switches in a dual-in-line package is sensed by the microprocessor and provides controlling functions for the alarms, output current and calibration – see Table 3.1.

		SW1							
		1	2	3	4	5	6	7	8
Current Output (mA)	0-10	ON	ON						
	0-20	OFF	OFF						
	4-20	OFF	ON						
Output Law	Linear Log.			OFF ON					
Low Cal. Solution	Standard Sample				OFF ON				
Range Group	1					OFF ON			
	2					ON			
Not used									
Alarm 2	Failsafe Normal							OFF ON	
Alarm 1	Failsafe Normal								OFF ON

**Table 3.1 Circuit Board Function Switch**

Range	Group 1 (SW1.5 OFF) 0.1 µg kg <sup>-1</sup> – 10 mg kg <sup>-1</sup>	Group 1 (SW1.5 ON) 0.01 µg kg <sup>-1</sup> – 1 mg kg <sup>-1</sup>
1	100 µg kg <sup>-1</sup> – 10 mg kg <sup>-1</sup>	10 µg kg <sup>-1</sup> – 1 mg kg <sup>-1</sup>
2	10 µg kg <sup>-1</sup> – 1 mg kg <sup>-1</sup>	1 – 100 µg kg <sup>-1</sup>
3	1 – 100 µg kg <sup>-1</sup>	0.1 – 10 µg kg <sup>-1</sup>
4	0.1 – 10 µg kg <sup>-1</sup>	0.01* – 1 µg kg <sup>-1</sup>

**Table 3.2 Range Groups**

\* Electronically, this is the lowest concentration which can be displayed; however, it is unlikely to be achieved in practice. Low concentration sodium measurements depend on sample and electrode conditions.

**3.2.4 Alarms**

**Note.** The alarms cannot be set during a calibration sequence.

Two sodium concentration alarm control relays are provided, each having one pair of changeover contacts rated at 2 A 250 V a.c. (non-inductive). Alarms 1 and 2 are designated as low and high alarms respectively. These values can be displayed by pressing the appropriate buttons on the front panel, and adjusted by pressing the UP/DOWN buttons.

Terminal connections for alarms are shown in Section 2.4 and switches SW1.7 and SW1.8 determine contacts which are closed in non-alarm conditions – see Section 3.2.3.

Functions are as follows:

- In NORMAL the relays are de-energized, i.e. NC contacts are closed.
- In FAIL-SAFE the relays are energized, i.e. NO contacts are closed. Thus if the power source fails, both external alarms are flagged indicating a malfunction.

Two other sets of relay contacts are provided. One set changes over during a calibration sequence and the other set changes over to indicate failure to calibrate .

**3.2.5 Analog Outputs (Table 3.2 & Fig. 3.6)**

Two identical isolated current outputs are available. Both outputs may be set to one of the three current ranges using switches SW1.1 and SW1.2. In each case the upper current limit corresponds to the full-scale reading of the range displayed on the front panel.

**Note.** If SW1.1 is set to ON and SW1.2 is set to OFF, no valid output is produced.

The two current outputs cover five decades of sodium concentration divided into four overlapping ranges. The overall range is determined by the RANGE GROUP selected by the position of SW1.5

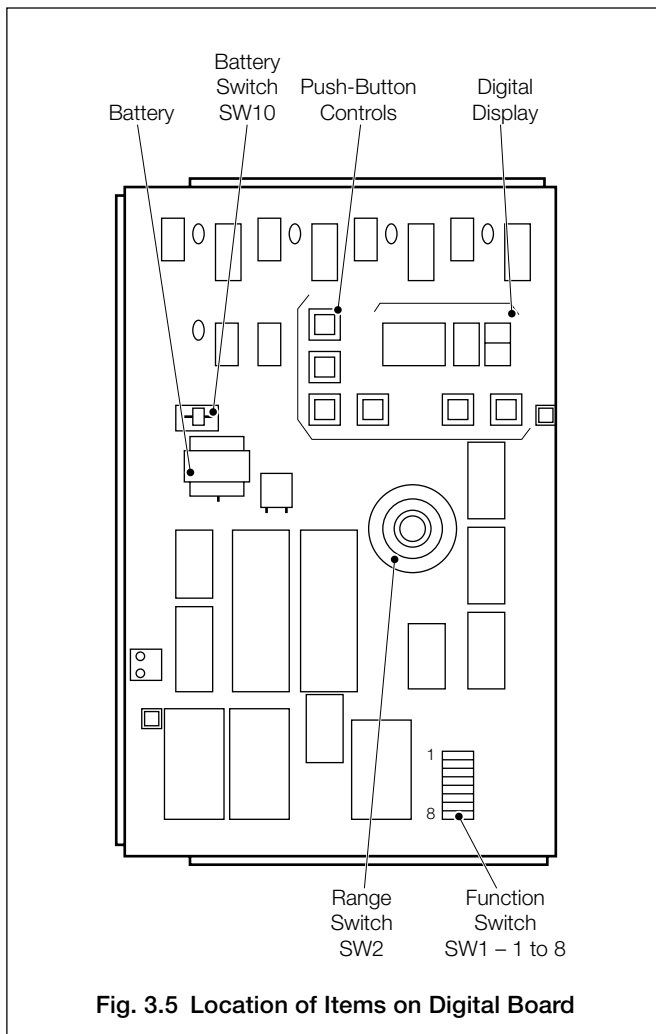

**Fig. 3.5 Location of Items on Digital Board**

### ...3 PRINCIPLE OF OPERATION

Within the selected RANGE GROUP both available current outputs represent two decades of sodium concentration at any one time. The RANGE SWITCH on the front panel selects manually RANGES 1 to 4, but in AUTO mode the monitor switches automatically between these ranges as the sodium concentration varies. The following points about ranges should be noted:

- The range selection only refers to the current output, the digital display covers the full range capability of the monitor.
- If the concentration is outside the individual range or RANGE GROUP selected, the digital display flashes - (reading) - 'out' - (reading) - 'out' -, in every other way the monitor functions normally.
- In AUTO, as the concentration increases, switching to the next range takes place at 100% of the current output, giving

a 50% output on the upper range (10% in linear output). When the concentration decreases, switching takes place at 0% of the current output, giving a 50% output on the lower range (10% in linear output). This gives a range switching hysteresis of one decade.

- At all times the current output range can be monitored or recorded remotely using the four remote RANGE INDICATION RELAY contacts.

The outputs can be set to LOGARITHMIC or LINEAR (determined by the position of SW1.3). When the LOGARITHMIC output is selected, the output represents two decades of concentration (e.g. 0.1 to 10, 1 to 100  $\mu\text{g kg}^{-1}$  etc.). When the LINEAR output is selected the output represents zero to the full-scale reading (e.g. 0 to 10, 0 to 100  $\mu\text{g kg}^{-1}$  etc.).

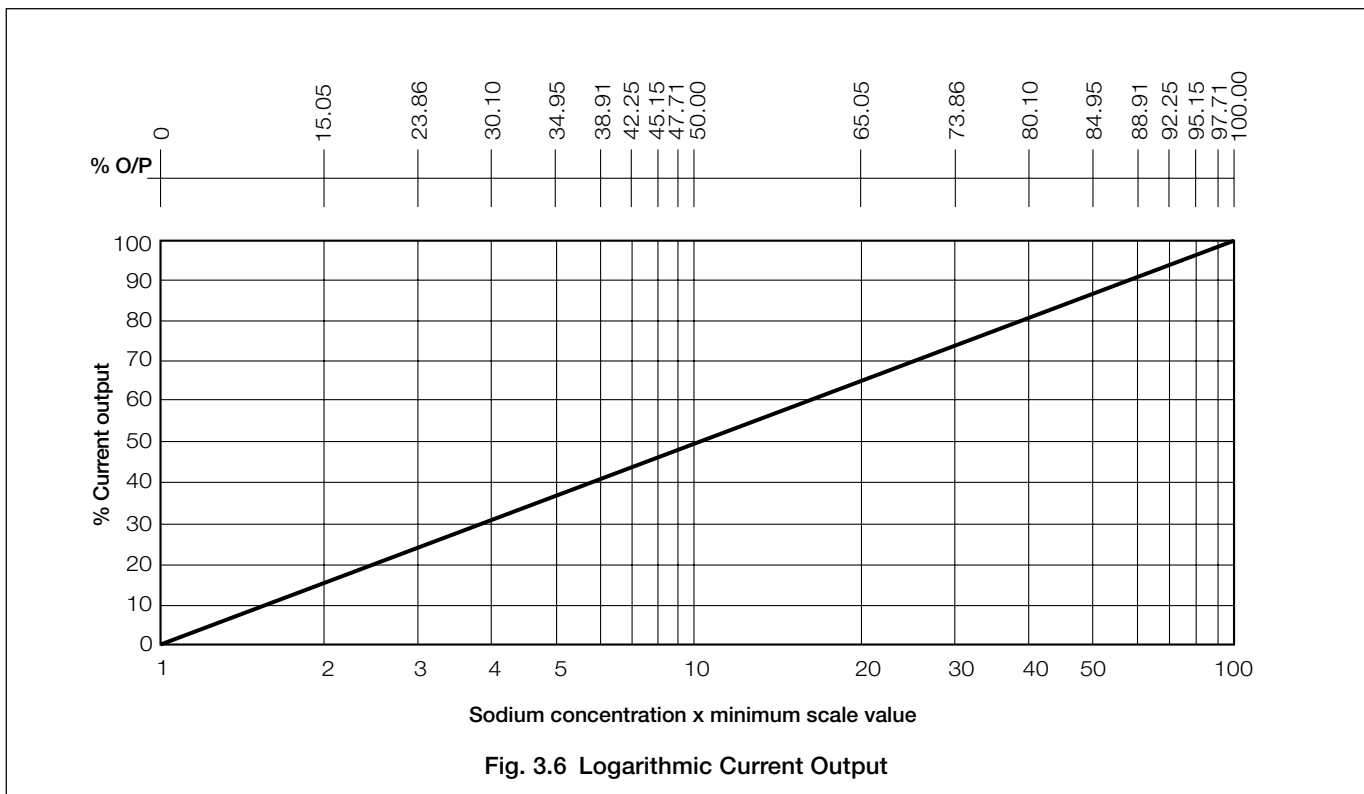

## 4 CALIBRATION PROCEDURE

Before starting an automatic calibration sequence, rinse the solution containers with high purity water and fill with fresh standard solution. If a single point calibration is to be done only one solution (STD1) is required. If a two point calibration is to be done, it is recommended that the lower value solution should be used first.

Either single or two point calibration can be done depending on the operating conditions. The slope of a sodium electrode is relatively stable, therefore frequent two point calibration may be unnecessary. It is suggested that single point calibration should be done weekly and two point calibration carried out monthly, but a suitable schedule must be determined to suit the operating conditions.

### 4.1 Single Point Calibration

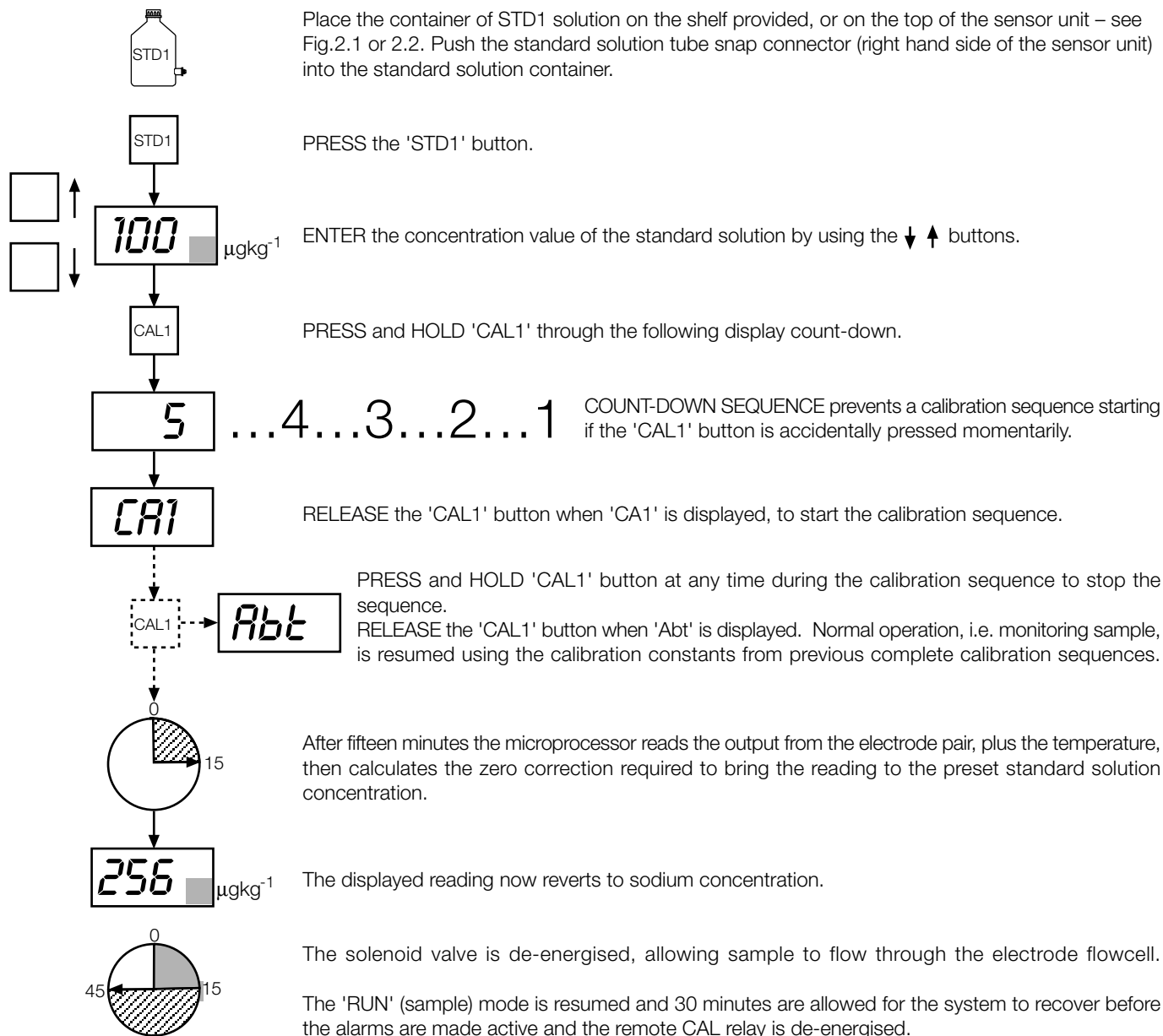

...continued on next page.

## ...4 CALIBRATION PROCEDURE

...continued from previous page.

### 4.2 Two Point Calibration

The following full calibration sequence takes approximately 60 minutes:

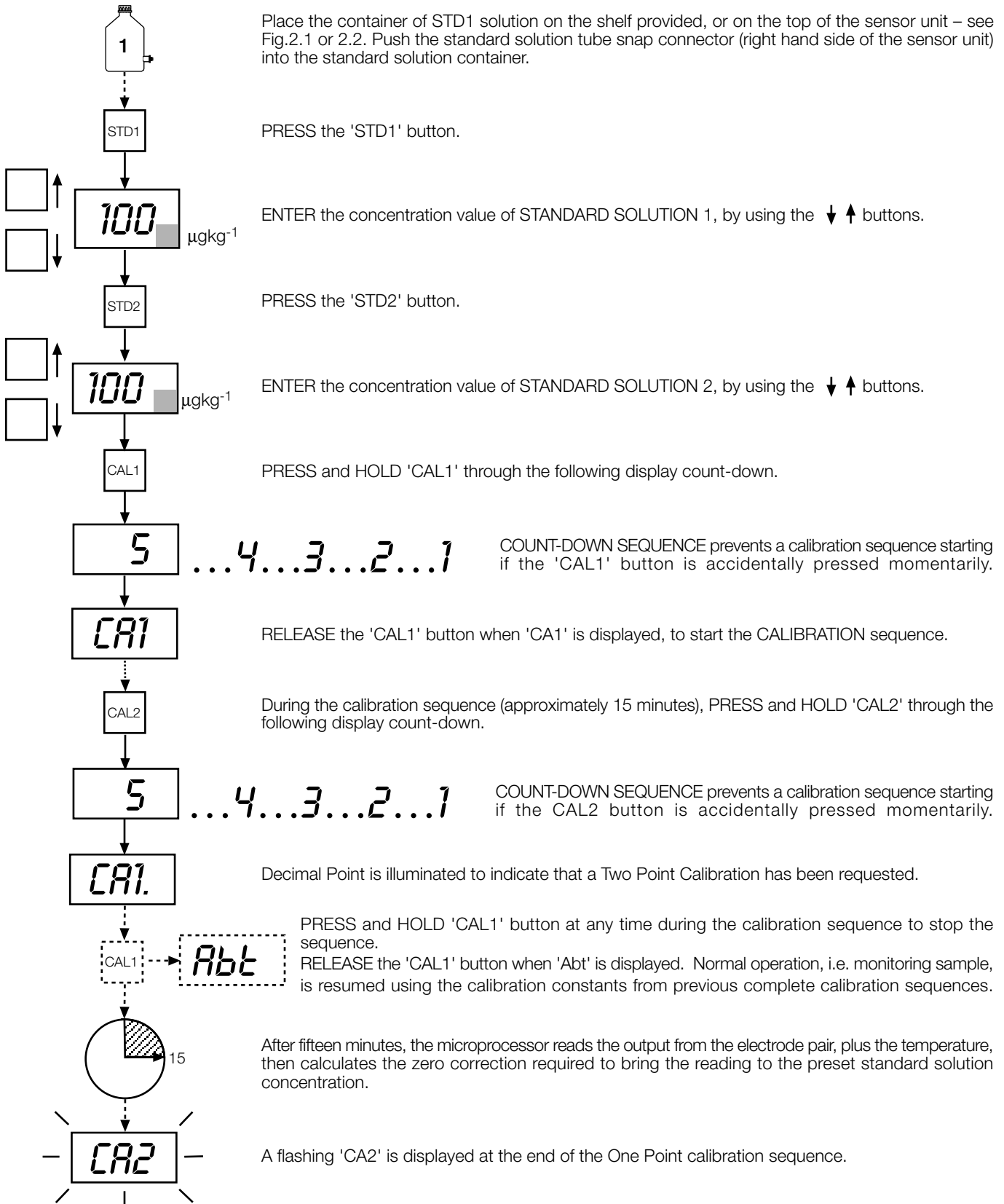

...continued from previous page

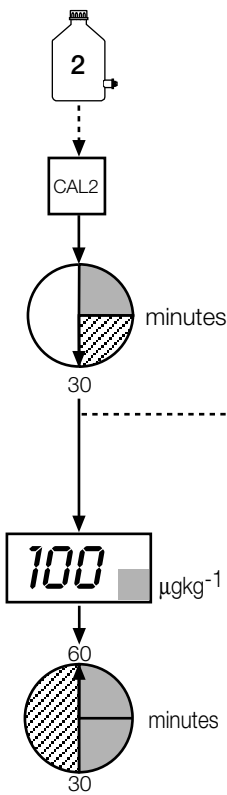

Disconnect the standard solution tube snap connector (right hand side of the sensor unit) from the STD1 container and remove the container. Place the container of STD2 solution on the shelf provided, or on the top of the sensor unit – see Fig.2.1 or 2.2. Push the standard solution tube snap connector into the STD2 standard solution container.

PRESS 'CAL2' button to continue the sequence.

**Note.** The two point calibration will be cancelled if the 'CAL2' button is not pressed within 15 minutes after the end of the first calibration.

Fifteen minutes after the 'CAL2' button is pressed, the microprocessor reads the output plus the temperature from the electrode pair, then calculates the slope correction required to bring the reading to the second preset standard solution concentration – see – Calibration Parameters, below.

CALIBRATION SEQUENCE ends if the slope value is above 83% – see Calibration Parameters, below. The display reverts to showing the sodium concentration.

The solenoid valve is de-energised, allowing sample to flow through the electrode flowcell.

The 'RUN' (sample) mode is resumed and 30 minutes are allowed for the system to recover before the alarms are made active and the remote CAL relay is de-energised.

### 4.3 Calibration Parameters

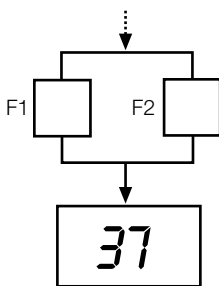

PRESS and HOLD 'F1' and 'F2' together, after a calibration, to display the mV offset. This is the difference between the voltage from the electrode and that expected from an ideal electrode (typical range expected in practice is  $\pm 50$  mV). The magnitude of the offset is not important; however, large deviations from one calibration to the next indicates instability and the cause should be investigated, e.g. a faulty sodium or reference electrode, poor connections etc. If, over many months, the offset is seen to be approaching the range limit ( $\pm 99$  mV), a replacement electrode pair should be considered.

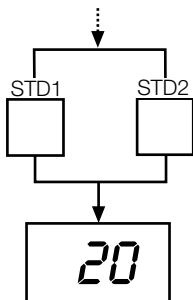

PRESS STD1 and STD2 together to display an indication of the electrode % slope value, which was calculated during the last TWO POINT CALIBRATION. If the slope value falls below about 83%, the external CAL FAIL alarm is activated and 'CF' is displayed. This indicates that the sodium electrode requires attention.

## 5 MAINTENANCE

### 5.1 Chemical Solutions

The reagents and calibration solutions detailed in this section are required to keep the monitor operating. Solutions should be stored in plastic bottles and where possible, should be freshly made.

#### 5.1.1 Reagent Solutions

**Warning.** These reagents are mildly toxic and hazardous, and should be handled with care.

Two alternative reagent solutions may be used, depending on the required lower limit of measurement. Concentrated ammonia solution, which provides adjustment of sample pH to 10.7 is suitable for measurements of sodium ion to approximately  $0.5 \mu\text{g kg}^{-1}$ . At concentrations below this, hydrogen ion interference becomes significant and a reagent of 50% diethylamine solution should be used. This adjusts the sample pH between 11.2 and 11.5 and enables measurements to be made to concentrations below  $0.1 \mu\text{g kg}^{-1}$ .

##### a) Concentrated ammonia solution – one litre.

**Warning.** This reagent should only be handled under a fume hood. It causes burns and is irritating to the eyes, respiratory system and skin. Wear rubber gloves and eye protection. In warm weather pressure increases in the bulk container of ammonia and the cap must be released with care.

A 35% w/v solution (s.g. 0.88) is recommended, but lower concentrations, to a minimum of 30% w/v (s.g. 0.89), can be used. Refer to section 5.4.2 which relates sodium concentration and pH.

##### b) Diethylamine Solution – (50%)

**Warning.** Diethylamine is an extremely flammable and irritating colourless liquid with a strong smell of ammonia. It should be handled with care at all times. The following points should also be noted:

- Avoid breathing vapour and avoid contact with skin and eyes.
- Work under a fume hood, wearing rubber gloves and eye protection.
- In the event of a fire, extinguish with water spray, foam, dry powder or carbon dioxide.
- If a spillage occurs, shut off all possible sources of ignition, and instruct others to keep at a safe distance. Mop up spillage with plenty of water, diluting greatly. Ventilate the area well to evaporate any remaining liquid and dispel vapour.
- Effluent from the monitor contains diethylamine (if this reagent is used). Contact with it should also be avoided.

Put 500 ml of high purity water into the reagent container and carefully add 500 ml of analytical reagent grade diethylamine ( $\text{C}_2\text{H}_5)_2\text{NH}$ . Swirl the solution and allow it to cool to room temperature before fitting the container cap.

#### 5.1.2 Standard Solutions

The following instructions refer to the preparation of  $100 \mu\text{g kg}^{-1}$  and  $1 \text{ mg kg}^{-1}$  sodium, LOW and HIGH standard solutions respectively, but any concentrations can be prepared within the measuring range selected by appropriate dilution of the stock solution.

Two litres of each standard solution are required:

- a) Dissolve  $2.543 (\pm 0.001)$  g of analytical reagent grade sodium chloride in approximately 100 ml high purity water. Transfer this solution to a one litre volumetric flask and make up to the one litre mark with more high purity water to give a stock solution of  $1000 \text{ mg kg}^{-1}$  sodium ions. Store in a plastic container.
- b) Pipette 10 ml of this solution to a one litre volumetric flask. Make up to the one litre mark with high purity water to give a solution of  $10 \text{ mg kg}^{-1}$  sodium ions.
- c) Pipette 20 ml of the  $10 \text{ mg kg}^{-1}$  solution into a two litre volumetric flask and make up to the two litre mark with high purity water to give the LOW standard solution of  $100 \mu\text{g kg}^{-1}$  sodium ions. Transfer this solution to the bottle labelled STANDARD SOLUTION 1 (LOW).
- d) Transfer 200 ml of the  $10 \text{ mg kg}^{-1}$  solution to a two litre volumetric flask and make up to the two litre mark with high purity water to give the HIGH standard solution of  $1 \text{ mg kg}^{-1}$  sodium ions. Transfer this solution to the bottle labelled STANDARD SOLUTION 2 (HIGH).
  - i) It is not advisable to prepare static sodium solutions of less than  $50 \mu\text{g kg}^{-1}$  because low concentration solutions rapidly become contaminated and change in concentration.
  - ii) Although the HIGH and LOW standard solutions are typically one decade apart in sodium concentration, any concentration difference can be used within the constraints of i) above and the need to have a significant change in electrode output to achieve an accurate calibration.

**Note.** High purity water = water containing less than  $2 \mu\text{g kg}^{-1}$  sodium ions and a specific conductivity of less than approximately  $0.2 \mu\text{S cm}^{-1}$ .

#### 5.1.3 Etch Solution

For use on applications where the sample sodium concentration is below  $1 \mu\text{g kg}^{-1}$  – see also Section 5.2.2.

**Warning.** Sodium Fluoride is toxic. Avoid inhaling the dust and prevent contact with skin and eyes. Wear a dust mask, rubber gloves and eye protection. When prepared, the etch solution contains 0.1 M Hydrofluoric acid (0.2% HF). Take care to prevent contact with skin and eyes.

### ...5.1.3 Etch Solution

Dissolve 5.0 ( $\pm 0.2$ ) g analytical grade sodium fluoride, NaF, in approximately 400 ml high purity water. Add to this solution 20 ( $\pm 0.2$ ) ml 5M acetic acid \*,  $\text{CH}_3\text{COOH}$ , and dilute to one litre.

\* 5M acetic acid can be prepared from concentrated acid by adding 144 ( $\pm 1$ ) ml analytical reagent grade glacial acetic acid (1.05 s.g.) to 500 ml of high purity water.

**Warning.** When preparing the acetic acid solution, carry out operation under a fume hood and observe the appropriate precautions when handling concentrated acids.

### 5.1.4 Salt Bridge Solution

This solution is required for refilling the silver/silver chloride reference electrode at extended intervals. A stock solution of 3.5 M potassium chloride is prepared by dissolving 26.1 g of analytical grade potassium chloride in approximately 90 ml high purity water and then diluting to 100 ml with more water. This solution should be stored in a tightly-stoppered plastic bottle. The electrode is most conveniently filled using a syringe.

## 5.2 Scheduled Servicing

The following procedures are guides to the maintenance requirements of the monitor. The procedure chosen depends on the particular installation and sample conditions.

### 5.2.1 Weekly

If the monitor is continuously running at high concentrations ( $>100 \mu\text{g kg}^{-1}$ ) a weekly Single Point Calibration is recommended – see Section 4.1.

### 5.2.2 Monthly

- a) Replace the bottle of reagent solution. The level of solution should not be allowed to fall below about three-quarters full. On low ambient temperature installations and for low sodium concentrations, the solution may require replacement more frequently.
- b) Check the level of reference electrode filling solution; refill as required.
- c) The following procedures should be carried out:
  - i) When the sodium concentration is above  $1 \mu\text{g kg}^{-1}$ , carry out a Two Point Calibration – see Section 4.2; note the slope value.
  - ii) When the sodium concentration is below  $1 \mu\text{g kg}^{-1}$ , apply the following reactivation/etch procedure before carrying out a Two Point Calibration:

**Note.** When used for prolonged periods at low concentrations, leeching of sodium ions from the electrode surface accelerates the ageing process of the electrode which is shown by poor response time, low slope value and a limitation to respond to low levels. Calibration may then be in error owing to slow response and poor reproducibility.

The reactivation procedure minimizes problems from these sources.

- 1) Remove the sodium electrode from the flowcell and slide off the sleeve and 'O' ring; it is unnecessary to detach the electrode lead.
- 2) Prepare two plastic beakers, one containing about 50 ml of etch solution, the other about 200 ml high purity water.
- 3) Dip the electrode in the etch solution for 60 ( $\pm 5$ ) seconds; then rinse in high purity water.

**Caution.** It is important not to exceed the etch time or the performance of the electrode may be permanently degraded.

- 4) Dispose of the etch solution by diluting to waste with plenty of water. Use fresh etch solution each time.
- 5) Fit the 'O' ring and sleeve and return the electrode to the flowcell. Run the monitor for one to two hours on low level sodium sample before attempting a calibration. No further calibration should be needed until the next reactivation procedure.

It is important that this procedure is carried out at regular monthly intervals and that the process is started as soon as a new electrode is put into service.

**Note.** It is extremely difficult to recover an 'old' electrode.

As the reagent solution, in most circumstances, is replaced monthly, the calibration procedure should be carried out 24 hours after replenishment to allow pH stability to be achieved.

This procedure applies to both ammonia and amine buffered systems.

### 5.2.3 3-Monthly

- a) Check the condition of all plastic tubing; replace it as required. Clean the flowcell to remove any deposits.
- b) Regenerate the desiccator by placing it in oven at  $130 \text{ }^\circ\text{C}$  for two hours.

## 5.3 Shut-Down Procedures

- a) Close the sample valve upstream of the monitor.
- b) Remove the reagent container and safely dispose of the solution. Rinse the containers thoroughly.

**Warning.** For safe handling instructions of reagent solutions refer to Section 5.1.1.

- c) Fill the calibration solution container with high purity water and do a single point calibration to flush the system.
- d) Remove the electrodes and follow procedure in Section 5.3.1.
- e) Use a syringe to flush all tubing with high purity water. This removes any particulate deposits.
- f) Switch off the mains supply to the Transmitter Unit.
- g) SW10 should be set to 'OFF' if the instrument is to be out of commission for longer than about one week.

### 5.3.1 Storage of Electrodes

Fill the rubber teat, supplied with the sodium electrode, with 1 mg kg<sup>-1</sup> sodium containing a few drops of concentrated ammonia solution – see Section 5.1.1 for safe handling of ammonia solutions. Push the teat over the end of the electrode. Fill the rubber teat supplied with the reference electrode with salt bridge solution and push the teat over the end of the electrode. Refit the filling hole plug to seal the refill aperture.

**Note.** Do not let either electrode dry out.

### 5.4 Unscheduled Servicing

Abnormal operation is shown on the I.e.d. display as follows:

#### Fault Possible cause

Display shows 'CAL1 or 'CAL2'	Normal display when calibration sequence is taking place. Display shows flashing 'CAL2' when waiting for CAL2 button to be pressed to start calibration on second solution.
Display flashes (reading) -'out'-	Sample concentration exceeds the range group selected.
Display shows 'CF' Calibration Fail	- the monitor was unable to achieve a successful calibration.
Display shows 'hot'	Sample temperature has risen above 55 °C – check cause.

#### 5.4.1 Calibration Fail alarm

A Calibration Fail condition occurs after a TWO POINT CALIBRATION when the calculated slope value is less than 83%. This could be caused by a number of factors which should be investigated. Some indication of the problem can be obtained by displaying the slope value "S%" (press STD1 and STD2 together).

##### a) Slope values just below 83%

- Check that vapour bubbles are emerging from the bottom of the stainless steel entrainment tube.
- Check the condition of the reagent solution.
- Reactivate the sodium electrode – see Sections 5.13 and 5.2.2. If the slope value is not improved following a further calibration, the electrode should be replaced.

##### (b) Very low or zero % slope

- Check the operation of the solenoid valve.
- Check flow of standard solution through flowcell.
- Check the level of the salt bridge solution in the reference electrode.
- Check for open-circuit reference electrode by substituting it with an electrode of known performance.

- Check all electrical connections in the electrode junction box and interconnection cable.

### 5.4.2 Malfunctions of the Monitor

These may produce many effects after calibration, some of which produce the following:

- Abnormal slope values – see Section 3.2.4.
- Display alternates between (value) and 'out'. A very large offset from the electrode takes the reading beyond the range of the monitor.

Any unpredictable problems may be due to the standard or reagent solutions. If doubts exist about the integrity of these solutions they should be replaced with freshly prepared solutions in the early stages of the fault finding investigations.

The accuracy of the monitor is controlled by the condition of all the solutions involved, one or more of which can be incorrectly made or contaminated.

Measuring the pH of the effluent from the flowcell indicates adequate buffering. The minimum pH depends on the minimum sodium concentration, but the pH value is calculated as:

pH must be greater than  $pNa + 3$ , so ideally at:

- 100 µg kg<sup>-1</sup> Na<sup>+</sup>, the pH must be greater than 8.4
- 10 µg kg<sup>-1</sup> Na<sup>+</sup>, the pH must be greater than 9.4
- 1 µg kg<sup>-1</sup> Na<sup>+</sup>, the pH must be greater than 10.4
- 0.1 µg kg<sup>-1</sup> Na<sup>+</sup>, the pH must be greater than 11.4

**Note.** If the reagent is allowed to become completely exhausted, the reading may be very erratic due to the lack of ionic strength adjustment of the high purity sample.

Mechanical components involved with liquid handling should be systematically checked for leaks or blockages as they change the chemical conditions around the electrode. Most problems are found to be associated with the chemistry and the liquid handling section.

### 5.4.3 Replacement of Plastic Tubing (Fig. 5.1)

In time certain sections of plastic tubing require replacement due to leakage, blockages, or poor condition. It is good practice to remove the liquid handling panel every twelve months for a complete refurbishment which includes replacing all plastic tubing. Use only the correct size and type of tube – see Fig. 5.1 for part numbers.

Two specific sections of tubing are critical:

- 1) Between the constant head unit and the entrainment 'T' piece: Cut 100 mm of the 1 mm i.d. silicon rubber tube and fit onto the tube connectors. The tube should be taut; any changes to this tube interfere with the flow and self starting characteristics.
- 2) Between the reagent container and entrainment 'T' piece; this must be a polyethylene lined tube which has good chemical resistance to the reagent.

### 5.4.4 Simple Electronic Check

Check the ability of the pre-amplifier and the transmitter unit to respond to an input in the following way:

- a) Disconnect the electrode leads from the terminals in the junction box on the Sensor Unit door.

- b) Connect a millivolt source to the electrode terminals:  
negative to 'Na+'  
positive to 'REF'  
link 'REF' to 'SCR'.
- c) Connect a 10 kohms resistor across terminals TH1 and TH2 in the transmitter unit to simulate 25 °C.
- d) Hold F2 and press RESET to set to the default calibration parameter values.
- e) Inject 200 mV and wait for two minutes.
- f) Note the reading on the display.
- g) Inject 259 mV and wait for two minutes.
- h) The reading should decrease by approximately one decade, e.g. from 95 to 9.5  $\mu\text{g kg}^{-1}$ . The exact change in reading is not important because this test is simply to check that the electronics respond to changes in input voltage.
- i) A further 59 mV decreases the reading by one decade.

The same procedure can be carried out using a pH simulator, injecting millivolts or equivalent pH values. Each pH unit change gives about one decade change on the display. A pH simulator also has the advantage of being able to check input insulation – see appropriate instruction manual for the simulator.

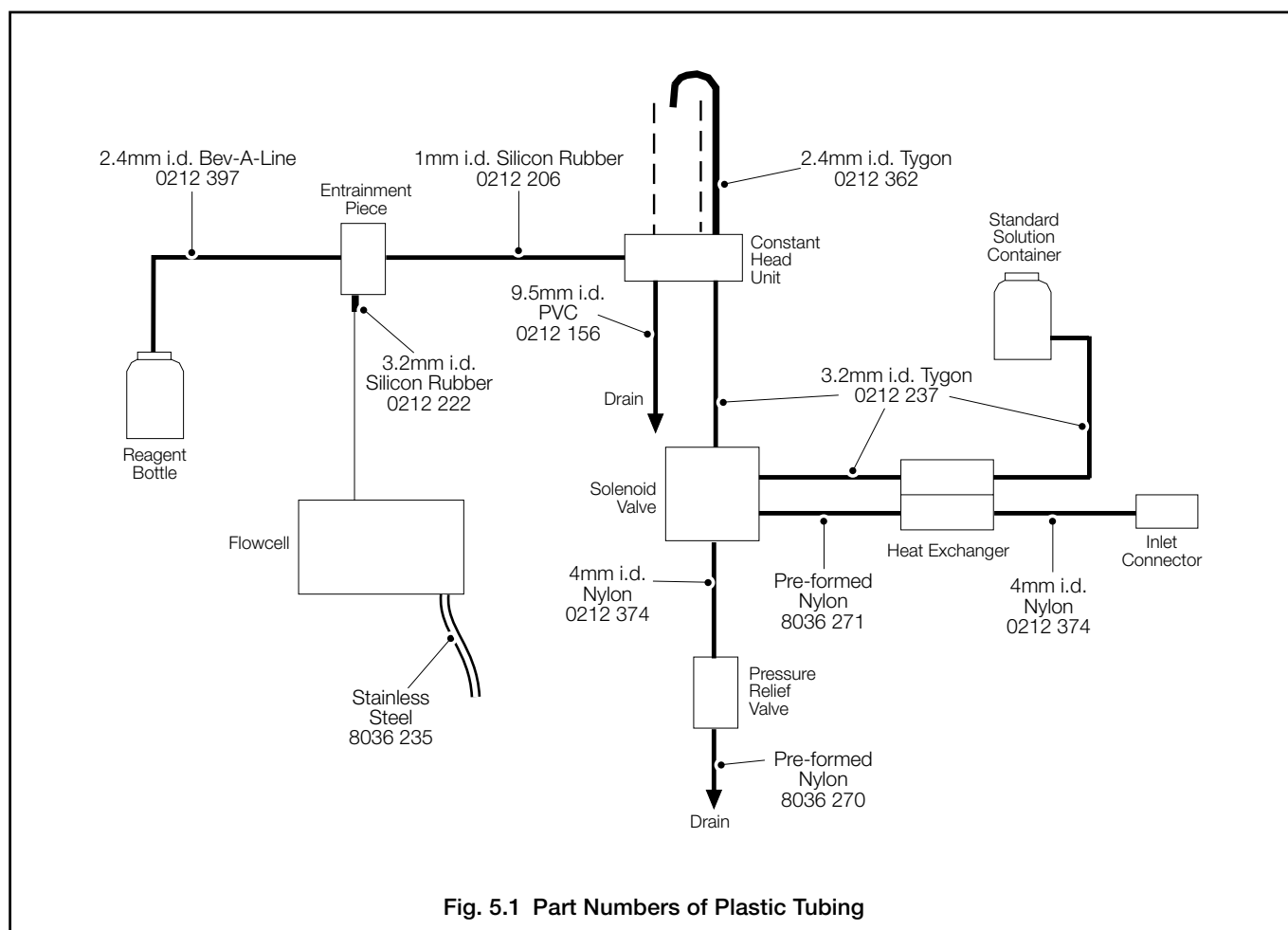

Fig. 5.1 Part Numbers of Plastic Tubing

## 6 SPARES LIST

No consumable spares are required for this instrument.

### Refurbishment Spares. One Year's Requirement.

Part no.	Description	No. Required
1048 836	Low level sodium electrode .....	1
1436 836	Silver/silver chloride reference electrode .....	1
8036 040	Annual Refurbishment Spares Kit ('O' rings and tubing) .....	1

### Strategic Spares Rarely Requiring Replacement

Part no.	Description	No. Required
8036 235	Tube stainless steel flowcell drain .....	1
0214 047	Tube connector 1.5 mm .....	6
0214 048	Tube connector 2.5 mm .....	6
0214 526	Hose connector 9.5 mm on constant head unit .....	1
0216 451	Tube connector used on solenoid valve .....	2
0216 452	Tube connector used on solenoid valve & inlet to pressure relief valve .....	2+1
0216 453	Tube connector outlet on pressure relief valve .....	1
8061 660	Knurled nut on flowcell .....	2
8036 216	Entrainment 'T' piece .....	1
8035 677	Entrainment/earthing tube .....	1
8036 247	Reagent container .....	1
8063 660	Reagent container cap assembly .....	1
8036 258	Standard solution container (LOW) .....	1
8036 262	Standard solution container (HIGH) .....	1
0216 449	Female connector on standard solution containers .....	2
0216 447	Male connector used on calibration tube assembly .....	1
8036 227	Thermistor in flowcell .....	1
0231 536	Fuse, 2A quick blow 20 x 5 mm .....	3
0232 971	Illuminated push switch .....	2
0211 683	Thermistor retaining bush .....	1
8036 180	Digital circuit board .....	1
7835 170	Analog circuit board .....	1
9435 160	Power supply circuit board .....	1
8036 050	Pre-amplifier/box assembly .....	1
8036 230	Flowcell complete assembly. (less electrodes) .....	1
8036 222	Solenoid valve assembly .....	1
8036 210	Constant head unit assembly .....	1
0216 454	Pressure relief valve .....	1
8036 236	Heat exchanger .....	1
1048 870	Sodium electrode cable assembly .....	1
1431 870	Reference electrode cable assembly .....	1
8036 286	Sodium electrode retaining sleeve .....	1

### Optional Extras

Part no.	Description
9435 040	Resistor kit for remote range Indication
9390 742	Shelf to support standard solution container

## 7 SPECIFICATION

Ranges	0.01 $\mu\text{g kg}^{-1}$ to 1 $\text{mg kg}^{-1}$ or 0.1 $\mu\text{g kg}^{-1}$ to 10 $\text{mg kg}^{-1}$ internally selectable.	Weight of Sensor Unit:	11 kg.
Accuracy	$\pm 10\%$ of concentration or $\pm 0.1 \mu\text{g kg}^{-1}$ whichever is the greater (when sample temperature is within $\pm 5^\circ\text{C}$ of calibration temperature).	Connections to Sensor Unit:	Sample inlet: 6.3 mm o.d. compression fitting. Sample drains: 10 mm flexible, atmospheric drain via gland, cable size 7 to 10.5 mm Electrical: 24/0.2 mm
Reproducibility	$\pm 5\%$ of concentration or 0.1 $\mu\text{g kg}^{-1}$ (whichever is the greater) at constant temperature.	Max. core size:	Mains: 32/0.2 mm Signal: 24/0.2 mm
Response Time	1 to 100 $\mu\text{g kg}^{-1}$ – less than 4 minutes for 90% step change 100 to 1 $\mu\text{g kg}^{-1}$ – less than 6 minutes for 90% step change.	Dimensions of Transmitter Unit:	300 mm wide x 300 mm high x 200 mm deep. CE Approved: 356 mm wide x 300 mm high x 200 mm deep.
Outputs	Two isolated current outputs in the range 0 to 10, 0 to 20 or 4 to 20 mA.	Mounting for Transmitter Unit:	Four Holes: 8.5 mm diameter 230 mm horizontal 230 mm vertical.
Maximum impedance	1 kohm Logarithmic or linear.	Weight of Transmitter Unit:	11 kg. CE Approved: 12 kg.
Remote Range	Four voltage-free contacts rated 125 V a.c.,	Electrical Connections:	Via gland plate to fit glands as required. CE Approved: Via glands in terminal box.
Indication	0.4 A non-inductive.	Power supply Requirements:	115/230 V, 50/60 Hz 100 VA.
External Alarms	Two normal or fail-safe, high and low concentration alarms. Calibration Mode indication. Calibration Fail indication. All voltage free 250 V, 2 A noninductive.	Power Supply Tolerances:	Voltage: +10% –20%. Frequency: minimum 47 Hz, maximum 65 Hz.
Calibration	Manual initiation of automatic calibration sequence. Calibration frequency 1 to 4 weeks depending on operating conditions.	Case Protection of Transmitter Unit:	IP55.
Battery Backup	Issue 6, 8036 180 digital boards: 10 years Prior to Issue 6: 4 weeks.	Maximum Distance between Sensor & Transmitter Unit:	100 meters. CE Approved: Nil.
<b>Installation Information</b>			
Sample Temperature:	5° to 55 °C.		
Sample Flow:	50 ml min <sup>-1</sup> to 500 ml min <sup>-1</sup> .		
Sample Pressure:	Minimum 0.14 bar (2 psi).		
Ambient Temperature:	0° to 55 °C.		
Dimensions of Sensor Unit:	300 mm wide x 400 mm high x 200 mm deep. CE Approved: 332 mm wide x 400 mm high x 200 mm deep.		
Mounting for Sensor Unit:	Four Holes 8.5 mm diameter 230 mm horizontal 330 mm vertical.		

# APPENDIX A

## A.1 Transmitter Unit

### A.1.1 Previous Type Digital Circuit Board

(8036 180 – prior to Issue 6, as marked)

This digital board was fitted to earlier versions of the monitor and is now superseded by the board described in the main text of this manual. The principle difference is the extension of the volatile memory on the later version. User programmable information on the earlier version is only retained for up to four weeks in unpowered conditions. Users of monitors with the earlier version board need to undertake additional tasks on a different board layout to the information given in the main text.

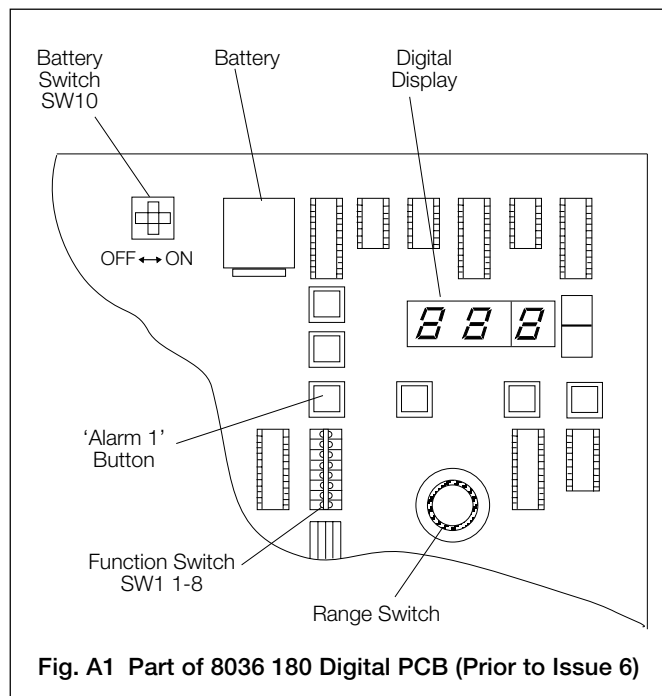

Fig. A1 Part of 8036 180 Digital PCB (Prior to Issue 6)

#### Setting digital circuit board

##### Function switch (SW1)

This is situated just below the ALARM 1 push button, and is a series of eight dual-in-line switches – See Fig. A2. This switch is functionally similar and set as described in the main text.

##### Battery switch (SW10)

This is located at the top of the board – See Fig. A2. This switch is functionally similar and operated as described in the main text. However, SW10 must be set to the 'OFF' position when the mains supply is switched off for periods greater than four weeks to prevent damage to the Nickel-Cadmium battery.

##### Other switches and controls

These are located as shown in Fig. A2, and are functionally similar and are operated as described in the main text.

##### Cold start

This takes place on reconnection of the mains supply when the mains supply was lost for longer than four weeks,\* or when the battery switch SW10 was set to OFF. Pressing RESET while holding F2 also initiates a COLD START.

After a COLD START the data in the volatile memory is lost, so the microprocessor:

- Sets Alarm 1 to minimum range value;
- Sets Alarm 2 to full scale;
- Reads default standard solution values on SW1.6;
- Sets the slope value to 100% and sets the zero offset to a default value.

Point d) enables the display to follow changes on the input to the Transmitter Unit, making electronics testing a simple operation.

The display permanently shows '888' after the mains supply has been connected. This indicates that the battery requires recharging. After approximately five minutes, normal operation can be resumed by pressing the RESET button. A TWO POINT CALIBRATION must now be carried out.

**Note.** Following a COLD START a full TWO POINT CALIBRATION is required before the instrument can produce valid sodium concentration values.

##### Warm start

This takes place when the mains supply has only been lost for a period of less than four weeks,\* when data held in the volatile memory is maintained. The instrument returns to normal operation, maintaining calibration, standard solution and alarm values previously held.

**\*Note.** This refers to 8036-180 digital boards prior to Issue 6. Issue 6 boards retain the memory for 10 years.

##### Sample temperature

The temperature of the sample water is continuously monitored by a thermistor housed in the flowcell.

If the temperature of the sample rises above 55 °C, the display shows 'hot'. After 30 minutes the temperature is again measured. This procedure repeats until the sample temperature is less than 55°C; the monitor then operates in the 'RUN' mode.

## A.2 Shut-Down Procedure

### A.2.1 Transmitter unit

Use the following procedure:

- Open the unit for access to the digital board. Remove the 17 screws, and turn the four plastic fasteners a 1/4 turn in either direction to release the escutcheon plate. Remove the escutcheon plate.
- Set the battery switch (SW 10) to 'OFF'.
- Fit the escutcheon plate and secure with the screws and fasteners.

### A.3 Spares List

Substitute the new Digital Circuit Board (part number 9435 180) as a replacement for the previous type. Check the new board against Section 3.2.3 and follow the procedures given in the main text in Section 2.4 and Section 2.6.

# PRODUCTS & CUSTOMER SUPPORT

## Products

### Automation Systems

- *for the following industries:*
  - Chemical & Pharmaceutical
  - Food & Beverage
  - Manufacturing
  - Metals and Minerals
  - Oil, Gas & Petrochemical
  - Pulp and Paper

### Drives and Motors

- *AC and DC Drives, AC and DC Machines, AC Motors to 1kV*
- *Drive Systems*
- *Force Measurement*
- *Servo Drives*

### Controllers & Recorders

- *Single and Multi-loop Controllers*
- *Circular Chart and Strip Chart Recorders*
- *Paperless Recorders*
- *Process Indicators*

### Flexible Automation

- *Industrial Robots and Robot Systems*

### Flow Measurement

- *Electromagnetic Flowmeters*
- *Mass Flow Meters*
- *Turbine Flowmeters*
- *Flow Elements*

### Marine Systems & Turbochargers

- *Electrical Systems*
- *Marine Equipment*
- *Offshore Retrofit and Refurbishment*

### Process Analytics

- *Process Gas Analysis*
- *Systems Integration*

### Transmitters

- *Pressure*
- *Temperature*
- *Level*
- *Interface Modules*

### Valves, Actuators and Positioners

- *Control Valves*
- *Actuators*
- *Positioners*

### Water, Gas & Industrial Analytics Instrumentation

- *pH, Conductivity and Dissolved Oxygen Transmitters and Sensors*
- *Ammonia, Nitrate, Phosphate, Silica, Sodium, Chloride, Fluoride, Dissolved Oxygen and Hydrazine Analyzers*
- *Zirconia Oxygen Analyzers, Katharometers, Hydrogen Purity and Purge-gas Monitors, Thermal Conductivity*

## Customer Support

We provide a comprehensive after sales service via a Worldwide Service Organization. Contact one of the following offices for details on your nearest Service and Repair Centre.

### United Kingdom

ABB Limited  
Tel: +44 (0)1453 826661  
Fax: +44 (0)1453 829671

### United States of America

ABB Inc.  
Tel: +1 (0) 775 850 4800  
Fax: +1 (0) 775 850 4808

#### Client Warranty

Prior to installation, the equipment referred to in this manual must be stored in a clean, dry environment, in accordance with the Company's published specification.

Periodic checks must be made on the equipment's condition. In the event of a failure under warranty, the following documentation must be provided as substantiation:

1. A listing evidencing process operation and alarm logs at time of failure.
2. Copies of all storage, installation, operating and maintenance records relating to the alleged faulty unit.

---

**ABB** has Sales & Customer Support  
expertise in over 100 countries worldwide

[www.abb.com](http://www.abb.com)

The Company's policy is one of continuous product  
improvement and the right is reserved to modify the  
information contained herein without notice.

Printed in UK (03.05)

© ABB 2005



**ABB Limited**  
Oldends Lane, Stonehouse  
Gloucestershire  
GL10 3TA  
UK  
Tel: +44 (0)1453 826661  
Fax: +44 (0)1453 829671

**ABB Inc.**  
Analytical Instruments  
9716 S. Virginia St., Ste. E  
Reno, Nevada 89521  
USA  
Tel: +1 (0) 775 850 4800  
Fax: +1 (0) 775 850 4808