



# ABB

## The Company

We are an established world force in the design and manufacture of instrumentation for industrial process control, flow measurement, gas and liquid analysis and environmental applications.

As a part of ABB, a world leader in process automation technology, we offer customers application expertise, service and support worldwide.

We are committed to teamwork, high quality manufacturing, advanced technology and unrivalled service and support.

The quality, accuracy and performance of the Company's products result from over 100 years experience, combined with a continuous program of innovative design and development to incorporate the latest technology.

The UKAS Calibration Laboratory No. 0255 is just one of ten flow calibration plants operated by the Company and is indicative of our dedication to quality and accuracy.

EN ISO 9001:2000



Cert. No. Q5907

EN 29001 (ISO 9001)



Lenno, Italy – Cert. No. 9/90A

Information in this manual is intended only to assist our customers in the efficient operation of our equipment. Use of this manual for any other purpose is specifically prohibited and its contents are not to be reproduced in full or part without prior approval of the Technical Publications Department.

### Health and Safety

To ensure that our products are safe and without risk to health, the following points must be noted:

1. The relevant sections of these instructions must be read carefully before proceeding.
2. Warning labels on containers and packages must be observed.
3. Installation, operation, maintenance and servicing must only be carried out by suitably trained personnel and in accordance with the information given.
4. Normal safety precautions must be taken to avoid the possibility of an accident occurring when operating in conditions of high pressure and/or temperature.
5. Chemicals must be stored away from heat, protected from temperature extremes and powders kept dry. Normal safe handling procedures must be used.
6. When disposing of chemicals ensure that no two chemicals are mixed.

Safety advice concerning the use of the equipment described in this manual or any relevant hazard data sheets (where applicable) may be obtained from the Company address on the back cover, together with servicing and spares information.

---

# CONTENTS

---

<b>1</b>	<b>INTRODUCTION .....</b>	<b>2</b>	<b>4</b>	<b>THEORY .....</b>	<b>16</b>
<b>2</b>	<b>GENERAL INFORMATION .....</b>	<b>3</b>	<b>5</b>	<b>SPECIFICATION .....</b>	<b>17</b>
2.1	Requirements .....	3	<b>6</b>	<b>SPARES &amp; ACCESSORIES .....</b>	<b>17</b>
2.2	Accessory Equipment .....	3			
2.3	Probe Assembly Instructions .....	3			
2.4	Storage .....	5			
2.5	Internal Filling Solution .....	5			
<b>3</b>	<b>PROBE MEASUREMENTS .....</b>	<b>5</b>		<b>APPENDIX .....</b>	<b>18</b>
3.1	General Procedure .....	5	A.1	Procedure for Chloridising the Reference Element .....	18
3.2	Buffer Solution – Sample pH .....	6	A.1.1	Requirements .....	18
3.3	Probe Calibration .....	8	A.1.2	Cleaning .....	18
3.4	Probe Range and Response .....	9	A.1.3	Chloridisation .....	18
3.5	Temperature Effects .....	9			
3.6	Interference .....	10			
3.7	Continuous flow analysis .....	10			
3.8	The Known Addition Method .....	12			
3.9	Modification of the Internal Filling Solution .....	12			
3.10	Analysis of Kjeldahl Digests .....	13			
3.10.1	Method .....	14			
3.10.2	Standard Solutions .....	14			
3.10.3	Probe Filling Solution .....	15			
3.11	Drift .....	15			
3.12	Ageing of the Glass Electrode .....	15			
3.13	Checking the Performance of the Glass Electrode .....	16			
3.14	Aging of the Reference Element .....	16			
				<b>REFERENCES .....</b>	<b>19</b>
				<b>NOTES .....</b>	<b>20</b>

# 1 INTRODUCTION

The Ammonia Probe, Model 8002, is a high sensitivity gas sensing probe developed by ABB. It measures the partial pressure, and hence concentration of ammonia in aqueous solution. Ammonium concentrations can be measured after the sample has been treated with alkaline buffer to generate ammonia. The probe has a Nernstian response up to 1000mg  $\text{NH}_3\text{J}^{-1}$  or 10,000mg  $\text{NH}_3\text{J}^{-1}$  with modification of the internal filling solution. The lower limit has not been determined as it is set by the purity of available water.

Model 8002 should be used in conjunction with an expanded scale pH meter such as Model 7046; for convenience the direct reading concentration scales may be used with the function switches set to monovalent anion. The probe is supplied with membranes and filling solution and a flow-through cap which enables continuous analyses of up to 60 samples per hour, when incorporated into a suitable flow system.

The probe may also be used as a sensor in industrial monitors, for example the Model 8232 Ammonia Monitor, an industrial continuous flow analyser incorporating automatic standardisation.

Model 8002 is widely used for the determination of ammonia in boiler water, river water, treated and untreated sewage, etc., (see References 2, 3, 5, 6, 7, 9 and 10). Total nitrogen in the forms of ammonia in the residue from the Kjeldahl digestion may also be measured quickly and easily with the probe without the need for the usual final distillation step, (see References 4 and 8). The internal filling solution of the probe must be modified in this application and in the measurement of other samples containing a high concentration of dissolved species.

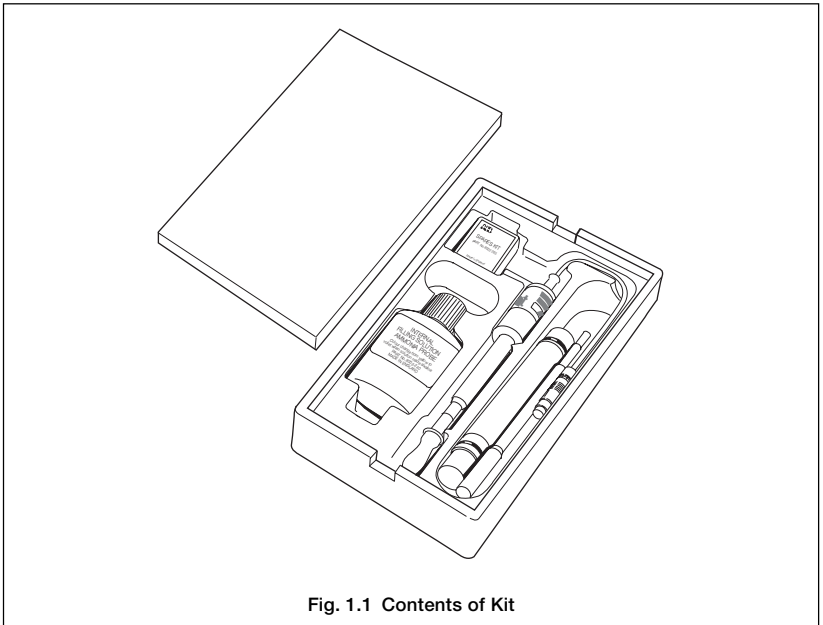

Fig. 1.1 Contents of Kit

## 2 GENERAL INFORMATION

### 2.1 Requirements

The following will be required in addition to the probe:

- a) An expanded scale pH meter, such as ABB Model 7046 (which has a direct reading concentration scale).
- b) Standard solutions of an ammonium salt.
- c) Alkaline buffer solution (see Section 3).
- d) Magnetic stirrer.

### 2.2 Accessory Equipment

**Note.** See list of spares and accessories.

Flow-through cap, Part No. 8002-830. This item is supplied with the kit. It allows samples to be pumped directly onto the sensing membrane of the probe. A simple closed flow system may be constructed using the cap. Further details are given in Section 3.

### 2.3 Probe Assembly Instructions

The probe takes only a few minutes to assemble, but for the best results the instructions must be followed carefully.

- a) Unscrew the end cap from the probe body. Rinse out the probe body with distilled or deionised water and allow to drain.
- b) Remove the teat from the glass electrode and rinse the electrode with distilled or deionised water. Dry with a paper tissue.
- c) Insert the glass electrode into the body and screw it in until the top of the electrode is flush with the end face of the probe. Note the number on the electrode cap in line with the mark on the probe body. Unscrew the electrode cap four full turns.

- d) Take one of the washers and a membrane from the spares kit. Carefully peel off the backing material from the membrane. Drop the washer into the end cap, then place the membrane on to the washer.
- e) Screw the end cap firmly onto the body: both the body seal and the membrane sealing washer should be under compression. The end cap should not be screwed on so tightly that the membrane wrinkles.

**Note.** If the probe is to be used to measure ammonia in sea water, it is recommended that 1.7 g of ammonium chloride and 1 drop (approximately 0.05 ml) of 0.1M silver nitrate is added to the contents of the 50 ml bottle.

- f) Hold the probe upright and fill the probe through the filling hole with the internal filling solution provided until there is a 50 to 60mm depth of solution inside. Wipe any excess filling solution from the body.
- g) Tap the end of the probe with a finger to dislodge any air bubbles which may have become trapped between the end of the glass electrode and the membrane. Then screw the glass electrode down four turns to the flush position again and then a further  $\frac{1}{3}$  to  $\frac{1}{2}$  turn. The tip of the electrode will now be pressing against the membrane. In some circumstances, particularly if the electrode response is found to be unusually slow, the screw may be given a further  $\frac{1}{4}$  turn.

**Note.** Screwing the electrode down too far may puncture the membrane.

- h) Push the probe cap onto the top of the probe body.

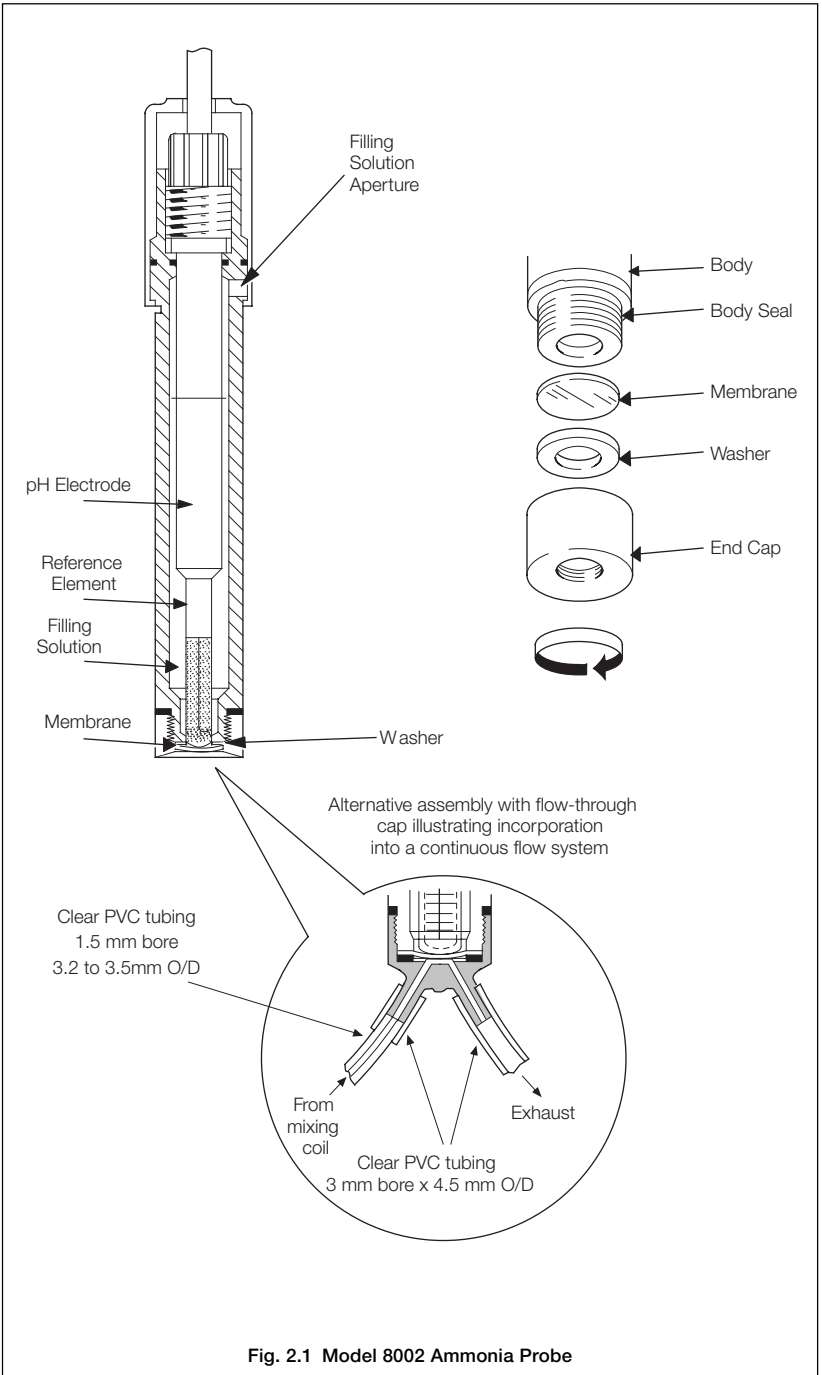

Fig. 2.1 Model 8002 Ammonia Probe

### **2.4 Storage**

Store the assembled probe with the end dipped into a 0.1M ammonium chloride solution in order to keep the osmotic pressure of the solutions on either side of the membrane equal – see Section 4. After storage the probe should be well rinsed in distilled or deionised water. Satisfactory results will not be obtained if the probe is stored in distilled or deionised water.

On no account should the end of the probe be allowed to dry out, should this accidentally occur the performance of the probe may sometimes be restored by loosening and tightening the electrode retaining nut to allow more filling solution to flow between the glass electrode and the membrane. If this procedure is not successful the membrane and filling solution need replacement.

If the probe is to be returned to its box it must be dismantled: firstly the glass electrode should be unscrewed, then the rest of the probe emptied, rinsed and drained. The glass electrode should be stored with its end in a teat containing a neutral buffer solution, taking care not to cover the reference element.

### **2.5 Internal Filling Solution**

The internal filling solution incorporates a coloured indicator which is normally yellow. The indicator changes to blue if the probe membrane, or membrane seal, allows alkaline reagent to leak into the probe. If this occurs the membrane and the filling solution should be replaced. Take care to tighten the end cap sufficiently to provide a good seal. The solution keeps indefinitely.

### **3.1 General Procedure**

For measurement of either the ammonium ion or 'total' ammonia concentration in samples, the samples must be alkaline when measured so that ammonia species are present as free ammonia. As most samples are not alkaline it is necessary to treat them with a buffer solution, the choice of which is explained in the following section.

Alkaline samples slowly lose ammonia so measurements in open beakers are not always satisfactory. Thus it is suggested that the samples are contained in 100ml conical flasks to reduce losses. The probe body will fit closely into the top of such a flask but losses may be further reduced by slipping the larger of the 'O' rings from the spares kit over the probe stem so that it makes a seal with the neck of the flask.

All samples should be stirred during measurement; this may conveniently be done using a magnetic stirrer. With some stirrers it will be necessary to put a sheet of thermal insulating material, such as polystyrene sheet, underneath the beaker to prevent heating of the sample by the stirrer motor.

After immersing the tip of the probe in a stirred sample check that no air bubbles are trapped on the end of the probe. Allow time for the probe potential to reach a steady value; the equilibration time will be dependent on the concentration of the ammonia in the sample. At a sample concentration of  $10^{-3}\text{M}$  ( $17\text{mg NH}_3\text{ l}^{-1}$ ) the time taken by the probe to reach its equilibrium potential should be under two minutes, although it may take longer with certain types of sample.

The probe is sensitive to the osmotic pressure of samples and special attention needs to be paid to this in the analysis of samples containing a high total concentration of dissolved species (i.e. the sum of the concentrations of all anions, or cations and non-dissociated species).

If this total concentration in the buffered sample presented to the probe is greater than 0.25M, the probe potential will drift. To overcome this problem either the samples should be diluted or the internal filling solution of the probe modified, as explained in a later section.

The probe is sensitive to changes in both ambient temperature and the temperature of samples, hence it is recommended that the probe is not used in direct sunlight or in a series of samples or standards at different temperatures. For the most accurate and reproducible results the probe should be kept at a constant temperature by use of a jacketed cell or by immersion of the lower half of the probe in a water bath (using the probe, fitted with a flow-through cap, in a flow system).

In addition to the measurement of 'total' ammonia in samples, the probe may also be used directly in untreated samples to measure the 'free' ammonia concentration. This is particularly useful in complex equilibria studies or in the measurements of strong ammonia solutions at fixed pH.

### **3.2 Buffer Solution – Sample pH**

The two functions of the buffer solution are to adjust the pH of the samples to greater than 11 so that all the ammonium ions are converted to ammonia and to fix the total concentration of dissolved species in the buffered sample at approximately 0.2M. In order to ensure virtually complete conversion of the ammonium ions it is necessary to have a sufficient excess of hydroxyl ions over the ammonium ions: to ensure the correct pH the final hydroxyl concentration should be at least two or three times the maximum ammonium ion concentration expected (both concentrations expressed as molarities).

Thus a 1M sodium hydroxide solution (NaOH) added to samples at a volume ratio of 1 : 10, is a suitable buffer for samples containing up to  $5 \times 10^{-2} \text{M NH}_4^+$  (ca.  $1000 \text{mg l}^{-1}$ ), provided the samples do not contain a high concentration of dissolved species. However for a sample which contains less than  $5 \times 10^{-3} \text{M NH}_4^+$  (ca.  $100 \text{mg l}^{-1}$ ) but has a total concentration of dissolved species of 0.2M, a suitable buffer for addition at a volume ratio of 1 : 10 is 0.1M NaOH, as this produces the correct pH while maintaining the correct level of dissolved species.

A correlation between % conversion and pH is shown in Fig. 3.1.

If samples contain small concentrations of metal ions, such as copper, nickel or mercury ions, these will complex part of the ammonia to be measured and cause a low result. Hence if such interferences are likely to be present it is advisable to replace the usual 1M NaOH solution with a buffer of 1M NaOH + 0.1M  $\text{Na}_2 \text{EDTA}$ .

For the analysis of samples containing greater than 0.25M total dissolved species or more than  $5 \times 10^{-2} \text{M NH}_4^+$ , see later section.

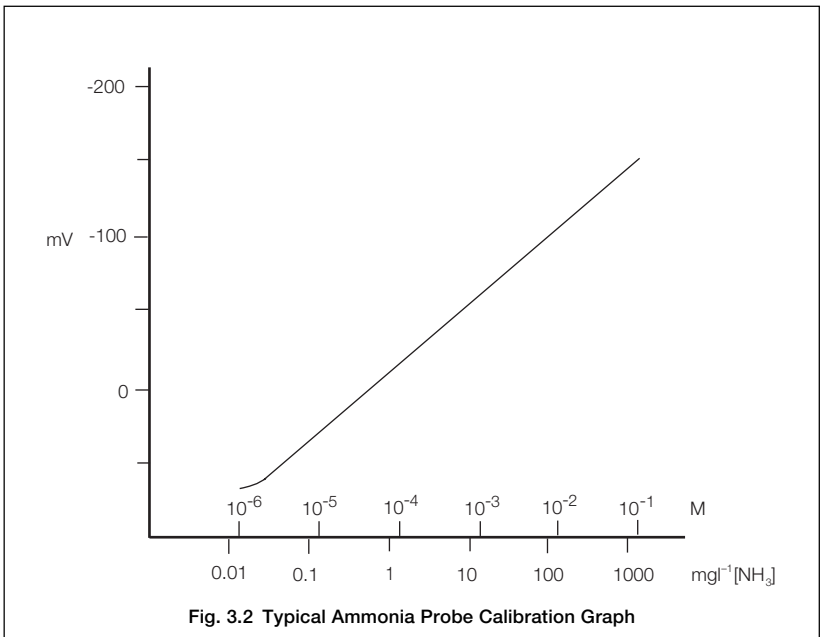
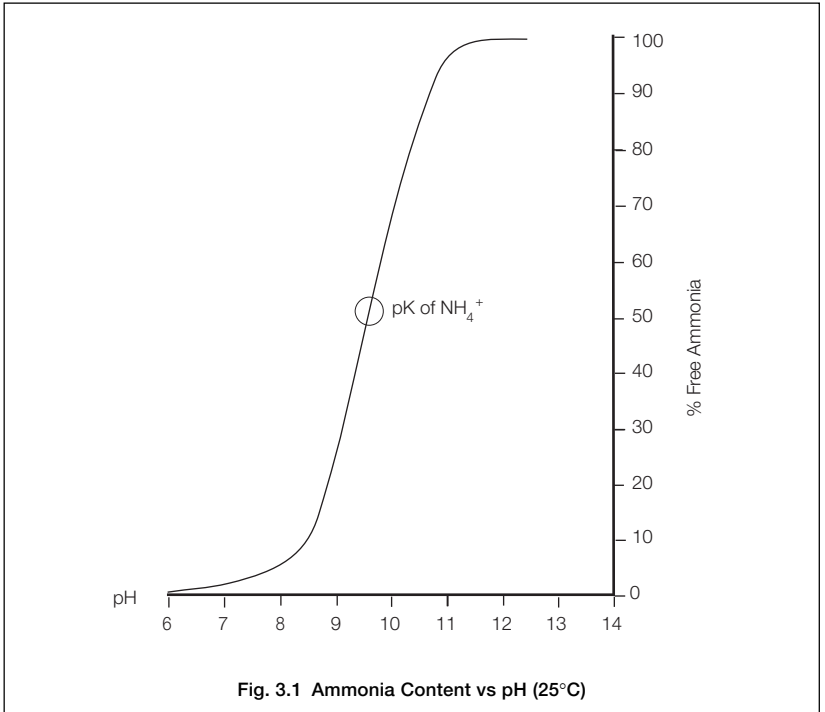

### 3.3 Probe Calibration

The probe should be calibrated regularly. After the calibration graph has been prepared, the calibration should be checked at a single point every two or three hours. The concentrations of the standard solutions used to calibrate the probe should be chosen to bracket the expected range of concentration of the samples.

The standard solutions for calibration of the probe may conveniently be prepared by serial dilution of fresh standard 0.1M or (if working in  $\text{mg l}^{-1}$  units) 2000  $\text{mg l}^{-1}$  ammonium chloride solution. The diluted standards are treated with a buffer as discussed in the previous section; typically 1 volume of 1M sodium hydroxide is added to every 10 volumes of standard. Record the potential of the probe in each of the buffered standards and prepare a calibration graph of the probe by plotting the potentials against the logarithm of the concentration of ammonium ions in the standards. This procedure is simplified if the graph is plotted on semi-logarithmic graph paper with the concentration along the logarithmic axis. A typical calibration graph is shown in Fig. 3.2.

If the level of ammonia contamination in the water and reagents is sufficiently low with respect to the lowest concentration of ammonia in standards and samples for the probe to give a Nernstian response in the required measurement range, then the calibration procedure may be simplified by using a pH meter with a direct reading concentration scale. Consult the pH meter instruction manual for the procedure. Use the monovalent anion setting on the function switch.

For accurate results the composition of the standards should be as similar as possible to that of the samples. Thus when the composition of the samples is well defined, standards should be prepared from the model samples with known amounts of added ammonium ion. In this way the constancy of the Henry's Law constant (see Section 4) between standards and samples is assured.

In common with other gas sensing membrane probes and many ion selective electrodes, the ammonia probe reaches equilibrium more quickly after an increase in determinand concentration than after a decrease. Accordingly it is recommended that the probe is calibrated in the standard solutions in ascending order of concentration.

The probe may be used to measure the 'free' ammonia in equilibrium with ammonium ions in samples. In such applications it is usually not satisfactory to pretreat the samples before measurement as this may upset the equilibria in the samples. The calibration of the probe for these measurements should be done with standards of known ammonia concentration after buffering; for example, one volume of a standard  $10^{-4}\text{M NH}_4^+$  buffered with one volume of 0.2M NaOH is a  $5 \times 10^{-5}\text{M NH}_3$  standard. Thus in this case the probe is calibrated against ammonia standards in place of the usual ammonium ion standards.

### 3.4 Probe Range and Response

The probe has a Nernstian response up to  $5 \times 10^{-2}\text{M}$  (approximately  $1000\text{mg NH}_3\text{I}^{-1}$ ); this range may be extended by modification of the internal filling solution. The lower limit of Nernstian response is set by the purity of reagents and water, as these inevitably contain small traces of ammonia; if no special care is taken the level of ammonia in distilled or deionised water usually produces a lower Nernstian limit of approximately 0.1 to 0.2mg  $\text{NH}_3\text{I}^{-1}$  (approximately  $10^{-5}\text{M}$ ).

The response times of the probe have been reported in Reference 1. The typical time taken for the probe to reach 1mV from the final equilibrium potential after a tenfold increase in ammonia concentration is 30 to 35 seconds.

The probe will drift if used continually near its upper limit; for the analysis of samples containing more than  $10^{-2}\text{M}$  (approximately  $200\text{mg NH}_3\text{I}^{-1}$ ) it is advisable to rinse the probe between measurements in 0.1M  $\text{NH}_4\text{Cl}$  solution, or briefly in distilled water, to prevent accumulation of ammonia in the bulk of the filling solution.

### 3.5 Temperature Effects

The temperature coefficient of the ammonia probe is approximately  $+1$  to  $+2\text{mV}/^\circ\text{C}$  depending on the conditions of measurement. Thus the probe should not be used in direct sunlight or in an area of rapidly changing temperature. Also the temperature of standards and samples should be held as constant as possible.

The temperature sensitivity of the probe arises from the temperature dependence of both of the electrodes' potentials, the osmotic equilibria and the positions of the equilibria of the chemical reactions.

The Nernst factor also varies with temperature and so the slope of the calibration graph as well as the normal potential of the probe vary. The theoretical values of the Nernst factor at different temperatures are given in Table 3.1.

$^\circ\text{C}$	$\text{mV}/\rho\text{NH}^3$	$^\circ\text{C}$	$\text{mV}/\rho\text{NH}^3$
5	55.19	25	59.16
10	56.18	30	60.15
15	57.17	35	61.14
20	58.17	40	62.13

**Table 3.1 Variation of Nernst Factor with Temperature**

A further temperature dependent parameter is the Henry's Law Constant; thus the partial pressure of ammonia in a solution of fixed concentration varies with temperature.

The effect of temperature on the probe is discussed in more detail in Reference 1.

### **3.6 Interference**

The probe is virtually free from interference. As the gas permeable membrane is hydrophobic, neither anions nor cations can interfere with the response. However, interference does result from volatile or filming amines in the solution, such as hydrazine, cyclohexylamine or octadecylamine, (see References 2 and 3); these produce an apparent increase in the ammonia concentration in the samples.

### **3.7 Continuous flow analysis**

The response of the probe is sufficiently rapid for it to be used for the continuous flow analysis of discrete samples. For this purpose, the flow-through cap is fitted onto the probe body in place of the standard end cap. A suitable flow system is shown in Fig. 3.3. Samples are separated by appropriate wash solution in the usual way. The flow rate through the cap should be approximately 2 to 5 ml per minute. Care must be taken to flush out air bubbles from the cap; this may be assisted by using narrow bore tubing (approximately 1mm) up to the cap inlet and only a short length of tubing on the outlet.

An example of a trace obtained with such a system is shown in Fig. 3.3 where ammonia samples were analysed at the rate of 60ml/hour. A higher sampling rate of 120/hour has been used and although the precision of the results was somewhat poorer, such rates would certainly be practical in many cases. The mixing coil in the Fig. 3.3 is necessary to ensure that the sample and buffer are thoroughly mixed before reaching the probe.

An ammonia probe has been used in this way for total nitrogen analysis by the Kjeldahl method as discussed in a later section and in Reference 4. After the digestion step the acidic digest is made alkaline and its ammonia content determined directly with the probe. The sample becomes hot after the alkali addition and the mixing coil and probe body were therefore immersed in a thermostatted water bath to ensure thermal stability; there is no danger of loss of ammonia because the alkali addition is made in a closed system.

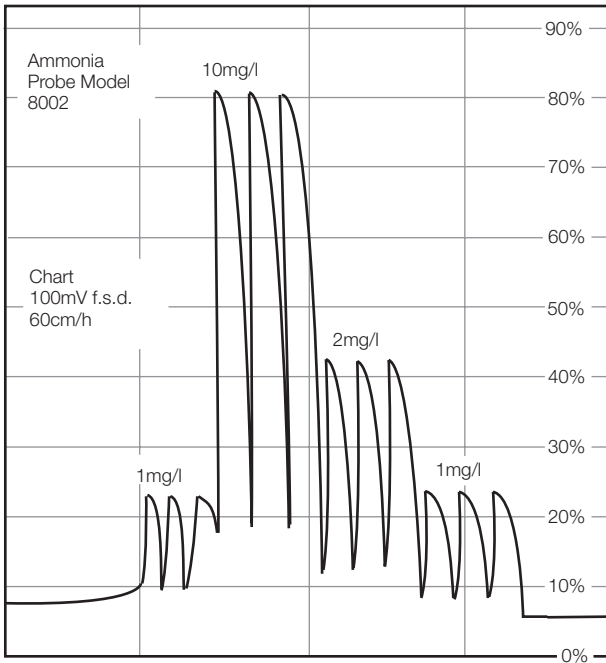

Traces Obtained from an Automatic Flow System

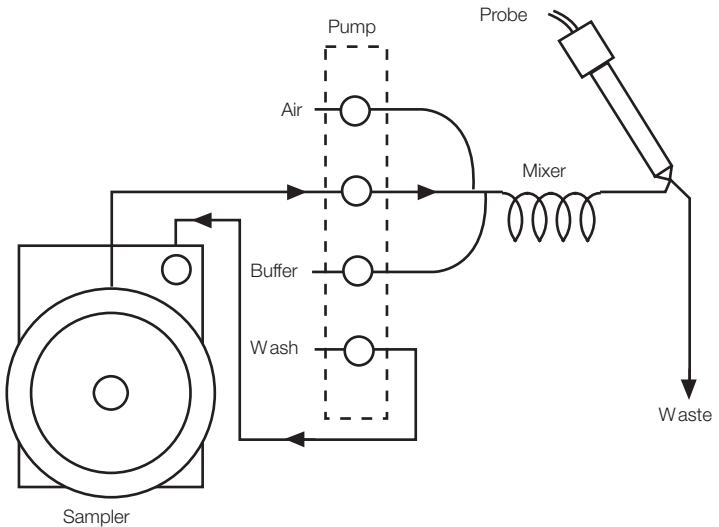

Fig. 3.3 Flow System

### 3.8 The Known Addition Method

There are some advantages in using the Known Addition Method of analysis for occasional samples with ammonia concentrations greater than the lower Nernstian limit in the experimental conditions used. This method reduces the number of standard solutions required to one; the concentration of this standard solution should be between ten and a hundred times that of the sample. The experimental slope factor ( $S$  mV/pNH<sub>3</sub>) of the probe should be known.

To analyse a sample by this method, pipette an aliquot,  $V_s$  ml, of alkaline sample into a beaker and measure the potential of the probe in this solution,  $E_1$  mV. Add a known volume,  $V_a$  ml, of the standard solution (where  $10V_a \ll V_s$ ) of concentration  $C_a$  mol l<sup>-1</sup> and after stirring measure the new potential of the probe,  $E_2$  mV. It should be so arranged that the potential change is several millivolts. The concentration of ammonia in the original alkaline sample,  $C_s$  mol l<sup>-1</sup>, may then be calculated from the formula:

$$C_s = \frac{\frac{C_a V_a}{V_a + V_s}}{\text{antilog}_{10} \left[ \frac{E_2 - E_1}{S} \right] \frac{V_s}{(V_a + V_s)}}$$

### 3.9 Modification of the Internal Filling Solution

For analysis of samples containing very high concentrations of ammonia the internal filling solutions must be modified to prevent the osmotic transfer of water across the membrane (see Reference 1). The internal filling solution provided in the kit consists principally of 0.1M ammonium chloride saturated with silver chloride.

In the case of measurements in strong ammonia solutions the molarity of ammonium chloride in the internal filling solution should be increased so that it is at least two or three times the molarity of the strongest ammonia solution to be analysed. Sufficient silver nitrate solution should be added to ensure that the solution is saturated with silver chloride. The buffer for treating the samples should be chosen so that the buffered samples have pH greater than 11 and the total concentration of dissolved species matches that in the new filling solution.

For measurements of samples containing a high total concentration of dissolved species, sufficient inert electrolyte, e.g. potassium nitrate, must be added to the filling solution so that the concentrations in the internal filling solution and buffered samples are equal. Such modification of the filling solution is necessary in the analysis of, for example, seawater or Kjeldahl digests. An example of the calculation of the correct concentration of inert electrolyte to add is given in the subsequent sections.

**Note.** A simple method for normal seawater analysis is to add 1.7 g of ammonium chloride and 1 drop (approximately 0.05 ml) of 0.1M silver nitrate to the contents of the 50 ml filling solution bottle.

### 3.10 Analysis of Kjeldahl Digests

The Ammonia probe can be used for the direct determination of the ammonia content of the residue from Kjeldahl digestions, thus eliminating the distillation step required before a colorimetric or titrimetric finish (Reference 4).

**Warning.** The normal safety procedures carried out during Kjeldahl digestions should always be observed.

After digestion of the sample the residue is cooled, diluted with ammonia free water and an aliquot is made alkaline for ammonia measurements with the probe. The exact procedure varies with the application but the important requirements are as follows:

- a) The initial dilution of the residue after digestion should be as large as possible to simplify the procedure. If the dilution factor is such that the total concentration of dissolved species in the solution presented exceeds 0.25M then the probe filling solution should be modified to prevent osmotic transfer of water through the membrane.
- b) Loss of ammonia during and after addition of alkali to the diluted residue must be prevented. Losses of ammonia can be minimised by efficient cooling to dissipate the heat of reaction.
- c) Standard solutions should be similar in composition to the diluted residue to avoid changes in the Henry's Law constant. In general it will be most convenient to use standard solutions containing the same concentration of sulphuric acid as the diluted residue.
- d) The temperature of all solutions presented to the probe should be essentially the same (see b above).
- e) If the digestion mixture contains a mercury catalyst, sodium iodide should be added to the alkaline buffer to prevent interference; for a copper catalyst EDTA should be added to prevent precipitation.

**Note.** Many of these requirements may be met by the use of a continuous flow system, as already noted.

**3.10.1 Method**

There are many variations of the Kjeldahl digestion process, but all result in a very acid residue of high dissolved solids content. With the above points in mind, a typical procedure can be outlined.

- a) Place sample containing 0.5 to 5.0 mg<sup>-1</sup>N in Kjeldahl flask.
- b) Add 10ml H<sub>2</sub>SO<sub>4</sub> (1.84 s.g.) and any catalyst and/or other additives required.
- c) Carry out digestion.
- d) After cooling make digest up to 100ml with ammonia free water.
- e) Pipette 25ml diluted digest into 100ml conical flask.
- f) Add 25ml buffer solution (4.0M NaOH), stopper the flask, Swirl and cool rapidly to the working temperature.
- g) Remove stopper, place magnetic stirrer bar in flask and insert probe containing modified filling solution.
- h) Stir the solution gently and note instrument reading immediately a stable potential is obtained.

The procedure in this section produces a final solution for measurement having the approximate composition:

0.90M Na<sub>2</sub>SO<sub>4</sub>

0.20M NaOH

and the standard solution and probe filling solution compositions can be calculated from this.

**3.10.2 Standard Solutions**

These should contain N in the ranges 5 to 50mg<sup>-1</sup> in the form NH<sub>4</sub>Cl. In addition, they should contain sulphuric acid, catalyst and other additives used for digestion; 1 litre of standard solution should contain ten times the amount of each of these used in step b) of the procedure in Section 3.10.1.

They should be treated in exactly the same way as the diluted digest, i.e. taken through steps e) to h) of Section 3.10.1.

### 3.10.3 Probe Filling Solution

The total concentration of dissolved species,  $\Sigma c_i$ , should be the same as that in the final solution, i.e.

$$\begin{aligned}\Sigma c_i &= (\text{Na}^+) + (\text{SO}_4^{2-}) + (\text{OH}^-) \\ &= ([2 \times 0.90] + 0.20) + 0.90 + 0.20\text{M} \\ &= 3.10\text{M}\end{aligned}$$

The standard filling solution is 0.1M  $\text{NH}_4\text{Cl}$  and this should be modified by the addition of solid  $\text{Na}_2\text{SO}_4$  to increase  $\Sigma c_i$  from 0.2 to 3.1M; this is achieved by the addition of 3.44g anhydrous  $\text{Na}_2\text{SO}_4$  to 25ml standard filling solution.

If the increase in  $\Sigma c_i$  is greater than 3.0M then NaCl should be used in place of  $\text{Na}_2\text{SO}_4$ .

The above calculation assumes that the solutions exhibit ideal behaviour, but this will not be the case in practice. Thus, in general, some drift in probe potential will still be observable and further adjustment of the probe filling solution may be necessary. If the probe potential drifts in the direction of lower ammonia concentration, then the filling solution requires more  $\text{Na}_2\text{SO}_4$  and vice versa. It is recommended that  $\Sigma c_i$  for the filling solution be changed in 5% increments until the drift is adequately small.

The matching of total concentration of dissolved species on either side of the probe membrane is more critical as the solutions become more concentrated; thus some preliminary dilution of the residue after digestion is advantageous.

### 3.11 Drift

Drift of the potential of the probe at a rate greater than 1mV in 12 hours should not be experienced. If greater drift does occur it is probably due to:

- inadequate temperature control;
- osmotic effects, i.e. total concentration of dissolved species in samples too high;
- loss of ammonia from the sample;
- use of the probe in very strong ammonia solution immediately prior to measurement;
- puncture of the membrane (usually visible);
- interference;
- ageing of the glass electrode – see Section 3.12.

### 3.12 Ageing of the Glass Electrode

After the probe has been in use for some months, the performance of the glass electrode may eventually deteriorate due to its continued use in weakly buffered solutions at near neutral pH. The response of the probe becomes sluggish and the response slope drops. The electrode may frequently be restored to its initial condition by soaking for 12 hours in 0.1M hydrochloric acid. The performance of the electrode may be checked as described below.

### 3.13 Checking the Performance of the Glass Electrode

The glass electrode may be checked independently of the probe with a laboratory calomel reference electrode (e.g. Model 1370 210) by testing the pair in pH buffer solutions.

The glass electrode should only be immersed to a depth of 5 to 10mm. There should be no liquid contact with the reference element.

Connect the electrodes to a pH meter and calibrate with pH buffers in the usual way. The glass electrode may be found to be somewhat slower in response than a conventional bulb type electrode, but adequate scale length should be obtained, typically better than 90% of the theoretical slope value.

### 3.14 Aging of the Reference Element

The silver chloride coating of the reference element gradually dissolves after many months use. If drift is experienced in an old electrode it could be due to this effect. Either replace the inner electrode (Part No. 8002-650) or CAREFULLY follow the chlorodisation procedure in Section 7.1.

The probe responds to the partial pressure of ammonia in the sample solution. When the probe is immersed in a sample, ammonia is transferred across the gas-permeable membrane until the partial pressure of the gas in the thin film of solution between the glass electrode and the membrane is equal to the partial pressure in the sample. The internal filling solution contains ammonium ions. The ratio of the amount of ammonia to the activity of these ions in the thin film gives rise to a characteristic pH which is measured by the glass electrode/reference electrode system. The value of this pH is a function of the chemical reactions in the solution. As a result of the equilibria the probe exhibits a potential in ammonia solutions which may be represented by:

$$E = E_{\infty} - \frac{2.3RT}{F} \log_{10} [\text{NH}_3]$$

Ammonia obeys Henry's Law in dilute solutions, so the partial pressure of ammonia in the solutions is directly proportional to its concentration, i.e.

$$\text{PNH}^3 = H[\text{NH}_3]_{\text{aq}}$$

where  $\text{PNH}^3$  is the partial pressure of ammonia,  $H$  is the Henry's Law constant and  $[\text{NH}_3]_{\text{aq}}$  the concentration of ammonia in the aqueous solution. The constant,  $H$ , is as previously discussed, a function of temperature but also of the total concentration of dissolved species in the solution. Thus the temperature and total concentration of dissolved species in samples should be as closely similar as possible to those of the calibration standards.

The effect of the osmotic pressure of samples on the probe response is discussed in Reference 1.

---

## 5 SPECIFICATION

---

### Concentration Range

0.1 mg<sup>-1</sup> to 1000mg<sup>-1</sup> NH<sub>3</sub>  
(5 x 10<sup>-6</sup>M to 5 x 10<sup>-2</sup>M)

### pH Range:

7 to 14pH

### Temperature Range:

5 to 40°C

### Reproducibility:

Better than ±2% of concentration

### Minimum Sample Size

5ml in a 50ml beaker

### Storage

Probe should be stored in 0.1M ammonium chloride solution.

**Caution.** Do not store dry.

### Life

Under normal operating conditions the probe life is at least 60 days without renewal of membrane

### Dimensions

Total Length 152mm  
Length below cap 105mm  
Stem diameter 17.5mm

---

## 6 SPARES & ACCESSORIES

---

Item	Part No.
Combination electrode assembly	8002 650
Flow-through cap	8002 830
Internal filling solution (50ml bottle)	8002 240
End cap	8002 820
Spares kit comprising: 10 membranes 1 silicone washer 1 pH electrode O-ring 2 O-rings (end cap & top cap) 1 O-ring (for use in flowcell)	8002 260

## APPENDIX

### A.1 Procedure for Chloridising the Reference Element

#### A.1.1 Requirements

- 1) Chemicals:
  - a) Plating solution Hydrochloric acid 0.1M (500ml)

**Note.** Do not use acid preserved with mercuric ions.

- b) Plating solution
  - c) Cleaning solutions:  
Ammonia solution 50% vol./vol. (200ml)

To prepare, dilute 100ml A.R. concentrated ammonia solution, s.g. 0.88, with 100ml distilled water and stir.

Nitric acid, 25% vol./vol. (200ml)

To prepare, cautiously pour 50ml A.R. concentrated nitric acid, s.g. 1.42, into 150ml distilled water, stirring continuously. Allow to cool before use.

**Caution.** Strong ammonia solutions and strong nitric acid are both very poisonous and corrosive. Care should be taken not to inhale the fumes of either or to get any on skin or clothing. Any slight spillage on skin, clothing or working surface should be washed away with plenty of water.

- 2) Hardware:  
Constant current supply, 2mA d.c. output  
  
Silver wire (counter electrode)  
  
1 beaker

#### A.1.2 Cleaning

Immerse the lower 5cm of the combination electrode (i.e. so that the silver reference element is covered) in the ammonia solution for about one minute. Remove and rinse with distilled water.

Immerse the electrode to the same depth in the 25% nitric acid until the silver element is a uniform creamy white. This process usually takes about one minute but the element must be **inspected frequently** as prolonged immersion is detrimental.

If the element is not uniform in colour repeat the ammonia/nitric acid process.

When clean, rinse with distilled water and immediately transfer to the plating solution such that the reference element is completely immersed.

#### A.1.3 Chloridisation

Attach the screen of the combination electrode cable to the negative terminal of the constant current supply and immerse the lower 5cm of the electrode in the plating solution so that the reference element is covered. Immerse a silver counter electrode in the plating solution and connect to the positive terminal of the supply.

Pass a current of 2mA for approximately 30 seconds. Carefully tap the electrode to remove all bubbles and then reverse the connections to the supply (i.e. the electrode to be plated is connected to the positive terminal).

Pass a current of 2mA for 30 minutes after which time the electrode will be a dark brown or grey colour. A more uniform coating may be obtained by employing moderate stirring during the process

Remove the electrode from the plating solution, rinse with /distilled water and dry with a tissue.

---

## REFERENCES

---

1. Performance characteristics of Gas Sensing Membrane Probes by P.L. Bailey and M. Riley Analyst, 1975, 100, 145.
2. Determination of Ammonia in Condensed Steam and Boiler Feed-water with a Potentiometric Ammonia Probe by D. Midgley and K. Torrance Analyst, 1972, 97,626.
3. Manual determination of Ammonia in Fresh Waters using an Ammonia sensitive membrane electrode by M. J. Beckett and A. L. Wilson Water Research, 1974, 8, 333.
4. Estimation of Nitrogen with an Ammonia Probe by G. K. Buckee Journal of the Institute of Brewing, 1974, 80, 291.
5. Determination of Ammonia levels in Water and Waste water with an Ammonia Probe by W. H. Evans and B. F. Partridge Analyst, 1974, 99, 367.
6. Electrometric Ammonia Determination in Plasma by G.T.B. Sanders and W. Thornton Clinica Chimica Acta, 1973, 46, 465.
7. A simple Method for the Estimation of Plasma Ammonia using an Ion Specific Electrode by N. J. Park and J.C.B. Fenton Journal of Clinical Pathology, 1973, 26, 802.
8. Use of the Ammonia Electrode for Determination of Nitrogen in Meat Products by P. M. Todd Journal of the Science of Food and Agriculture, 1973, 24, 488.
9. Continuous Determination of Ammonia in Condensed Steam and High purity Boiler Feed-water by Using a Potentiometric Ammonia Probe. by D. Midgley and K. Torrance Analyst, 1973, 98, 217.
10. On-Stream Determination of Ammonia in Boiler Feed-water with an Ammonium Ion Selective Electrode and an Ammonia Probe by J. Mertens, P. Van den Winkel and D. L. Massart Bull. Soc. Chim. Belg., 1974, 83, 19.
11. Semi-automated Ammonia Probe Determination of Kjeldahl Nitrogen in Fresh waters by R. J. Stevens Water Research, 1976, 10, 171.
12. Total Nitrogen Estimation in Herbage and Soils using the Ammonia Gas sensing Electrode by A. J. Clark Laboratory Practice, 1979, 28, No.10.



# PRODUCTS & CUSTOMER SUPPORT

## Products

### Automation Systems

- *for the following industries:*
  - Chemical & Pharmaceutical
  - Food & Beverage
  - Manufacturing
  - Metals and Minerals
  - Oil, Gas & Petrochemical
  - Pulp and Paper

### Drives and Motors

- *AC and DC Drives, AC and DC Machines, AC motors to 1kV*
- *Drive systems*
- *Force Measurement*
- *Servo Drives*

### Controllers & Recorders

- *Single and Multi-loop Controllers*
- *Circular Chart and Strip Chart Recorders*
- *Paperless Recorders*
- *Process Indicators*

### Flexible Automation

- *Industrial Robots and Robot Systems*

### Flow Measurement

- *Electromagnetic Flowmeters*
- *Mass Flowmeters*
- *Turbine Flowmeters*
- *Wedge Flow Elements*

### Marine Systems & Turbochargers

- *Electrical Systems*
- *Marine Equipment*
- *Offshore Retrofit and Refurbishment*

### Process Analytics

- *Process Gas Analysis*
- *Systems Integration*

### Transmitters

- *Pressure*
- *Temperature*
- *Level*
- *Interface Modules*

### Valves, Actuators and Positioners

- *Control Valves*
- *Actuators*
- *Positioners*

### Water, Gas & Industrial Analytics Instrumentation

- *pH, Conductivity and Dissolved Oxygen Transmitters and Sensors*
- *Ammonia, Nitrate, Phosphate, Silica, Sodium, Chloride, Fluoride, Dissolved Oxygen and Hydrazine Analyzers.*
- *Zirconia Oxygen Analyzers, Katharometers, Hydrogen Purity and Purge-gas Monitors, Thermal Conductivity.*

## Customer Support

We provide a comprehensive after sales service via a Worldwide Service Organization. Contact one of the following offices for details on your nearest Service and Repair Centre.

### UK

ABB Limited  
Tel: +44 (0)1453 826661  
Fax: +44 (0)1453 829671

### USA

ABB Inc.  
Tel: +1 215 674 6000  
Fax: +1 215 674 7183

### Client Warranty

Prior to installation, the equipment referred to in this manual must be stored in a clean, dry environment, in accordance with the Company's published specification.

Periodic checks must be made on the equipment's condition. In the event of a failure under warranty, the following documentation must be provided as substantiation:

1. A listing evidencing process operation and alarm logs at time of failure.
2. Copies of all storage, installation, operating and maintenance records relating to the alleged faulty unit.

---

**ABB** has Sales & Customer Support  
expertise in over 100 countries worldwide

[www.abb.com](http://www.abb.com)

The Company's policy is one of continuous product  
improvement and the right is reserved to modify the  
information contained herein without notice.

Printed in UK (06.08)

© ABB 2008



**ABB Limited**

Oldends Lane Stonehouse  
Gloucestershire  
GL10 3TA  
UK

Tel: +44 (0)1453 826661  
Fax: +44 (0)1453 829671

**ABB Inc.**

125 E County Line Road  
Warminster  
PA 18974  
USA

Tel: +1 215 674 6000  
Fax: +1 215 674 7183