



ABB

The Company

We are an established world force in the design and manufacture of instrumentation for industrial process control, flow measurement, gas and liquid analysis and environmental applications.

As a part of ABB, a world leader in process automation technology, we offer customers application expertise, service and support worldwide.

We are committed to teamwork, high quality manufacturing, advanced technology and unrivalled service and support.

The quality, accuracy and performance of the Company's products result from over 100 years experience, combined with a continuous program of innovative design and development to incorporate the latest technology.

The UKAS Calibration Laboratory No. 0255 is just one of the ten flow calibration plants operated by the Company and is indicative of our dedication to quality and accuracy.

EN ISO 9001:2000



Cert. No. Q 05907

EN 29001 (ISO 9001)



Lenno, Italy – Cert. No. 9/90A

Stonehouse, U.K.



0255

Information in this manual is intended only to assist our customers in the efficient operation of our equipment. Use of this manual for any other purpose is specifically prohibited and its contents are not to be reproduced in full or part without prior approval of the Technical Publications Department.

Health and Safety

To ensure that our products are safe and without risk to health, the following points must be noted:

1. The relevant sections of these instructions must be read carefully before proceeding.
2. Warning labels on containers and packages must be observed.
3. Installation, operation, maintenance and servicing must only be carried out by suitably trained personnel and in accordance with the information given.
4. Normal safety precautions must be taken to avoid the possibility of an accident occurring when operating in conditions of high pressure and/or temperature.
5. Chemicals must be stored away from heat, protected from temperature extremes and powders kept dry. Normal safe handling procedures must be used.
6. When disposing of chemicals ensure that no two chemicals are mixed.

Safety advice concerning the use of the equipment described in this manual or any relevant hazard data sheets (where applicable) may be obtained from the Company address on the back cover, together with servicing and spares information.

CONTENTS

1	INTRODUCTION	1
2	SYSTEM TYPES	2
2.1	Unpacking	2
2.2	Floating Ball System	2
2.2.1	Assembled Version	2
2.2.2	Kit Version	2
2.3	Dip Systems	3
2.3.1	Assembled Version	3
2.3.2	Kit Version	3
2.4	Submersible System	3
3	MECHANICAL INSTALLATION	4
3.1	Assembling Kit Systems	4
3.1.1	Floating Ball	4
3.1.2	Dip	5
3.2	Installation	6
3.2.1	Floating Ball System	6
3.2.2	Dip Systems	7
3.2.3	Submersible Systems	7
3.3	Water Supply for Water Wash Systems	8
4	ELECTRICAL INSTALLATION	9
4.1	Connection to the Dissolved Oxygen Transmitter	9
4.2	Calibrating the Sensor	9
5	MAINTENANCE	10
5.1	Replacing the Oxygen Sensor Capsule	10
5.1.1	Floating Ball System	10
5.1.2	Dip Systems	11
5.1.3	Submersible Systems	11
5.2	Replacing the Oxygen Sensor Block	11
5.2.1	Floating Ball System	11
5.2.2	Dip Systems	11
5.2.3	Submersible Systems	12
5.3	Changing the Temperature Compensator	12
5.3.1	Floating Ball and Dip Systems	12
5.3.2	Submersible System	12
6	SPECIFICATION	12
7	SPARE PARTS LIST	13
7.1	Floating Ball System	13
7.2	Dip System	13
7.3	Submersible System	13
APPENDIX A – SUPPORT BRACKET CONVERSION		
A1	Kit Parts List	14
A2	Conversion Procedure	14

1 INTRODUCTION

The ABB Model 9408 Floating Ball is a dissolved oxygen measuring system primarily for use in sewage treatment works where fouling of the dissolved oxygen sensor by rags or other large solids is a common occurrence.

To prevent this contamination, a flat ended sensor is mounted inside a relatively large diameter flotation collar, and therefore presents a surface to the contaminant upon which it is almost impossible for the contaminant to collect.

Two other systems are available:

- dip
- submersible

which are for use in open tanks and where access is difficult. See below for a list of variations.

All measuring systems are compatible with the 4640 and 4645 dissolved oxygen transmitters.

A water wash option is available on all dissolved oxygen systems described in this manual. Optional items are shown in illustrations as dotted lines.

Information. To enable easy access to the floating ball sensor a conversion kit is available which converts the standard bracket into a swivel bracket – see appendix for ordering and conversion information.

The following systems are currently available:

Floating Ball

Assembled

Standard	9408 700
With water wash	9408 702

Metric kit

Standard	9408 750
With water wash	9408 752

Imperial kit

Standard	9408 760
With water wash	9408 762

Dip

Assembled

Standard	9408 710 (1 m)
	9408 720 (2 m)
	9408 730 (3 m)
With water wash	9408 712 (1 m)
	9408 722 (2 m)
	9408 732 (3 m)

Imperial kit

Standard	9408 771
With water wash	9408 773

Submersible

Standard	9408 600
With water wash	9408 602

2 SYSTEM TYPES

2.1 Unpacking

After carefully removing the 9408 system from its packing, check that the following systems include the associated items and that they are in good condition.

2.2 Floating Ball System

2.2.1 Assembled Version

The system (9408 700 and 702) is fully assembled with a 3 metre boom except for the oxygen sensor capsule (8012 170). Dimensions are as shown in Fig. 2.1b.

2.2.2 Kit Version – Fig. 2.1

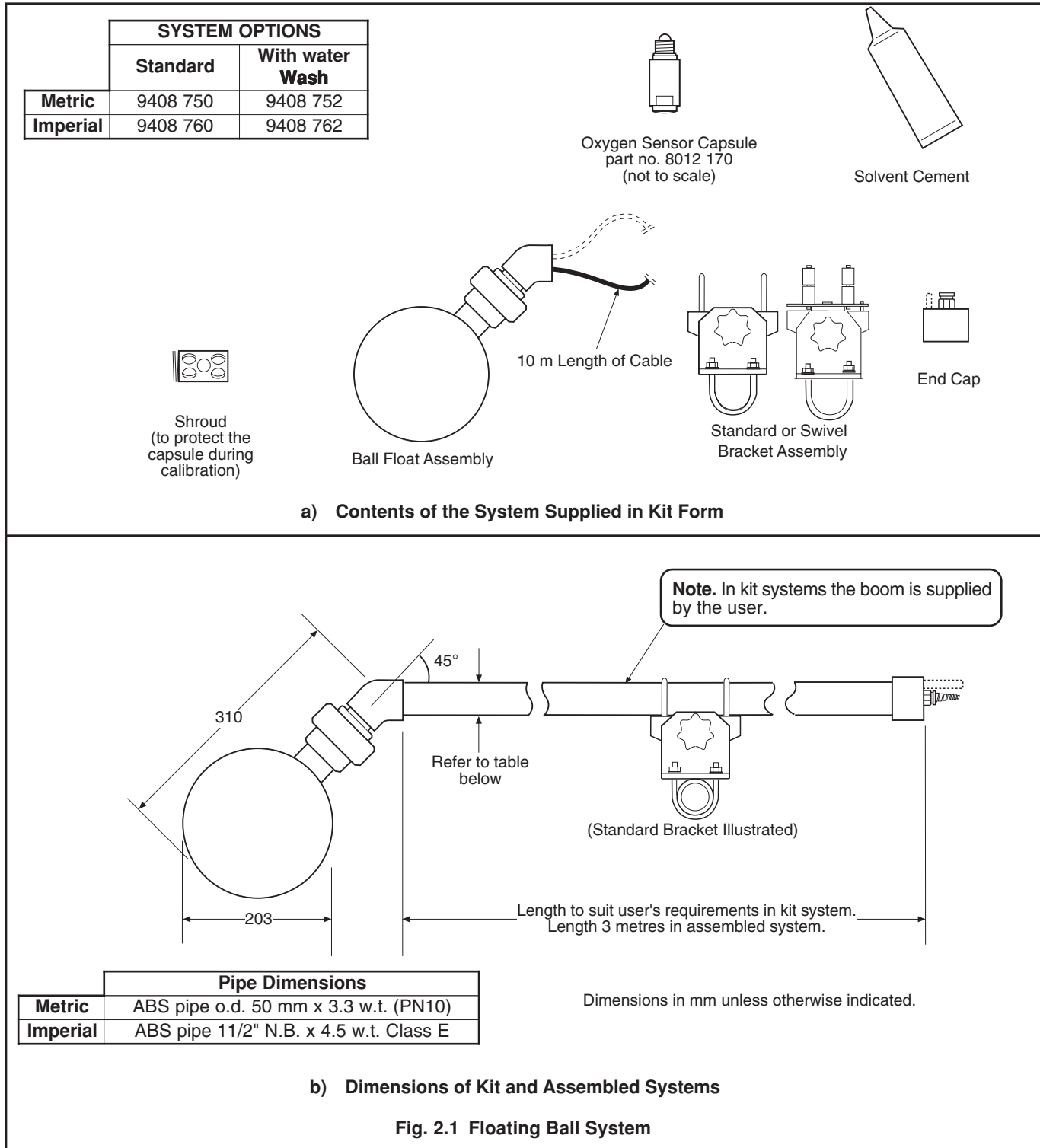

2.3 Dip Systems

2.3.1 Assembled Version – Fig. 2.2

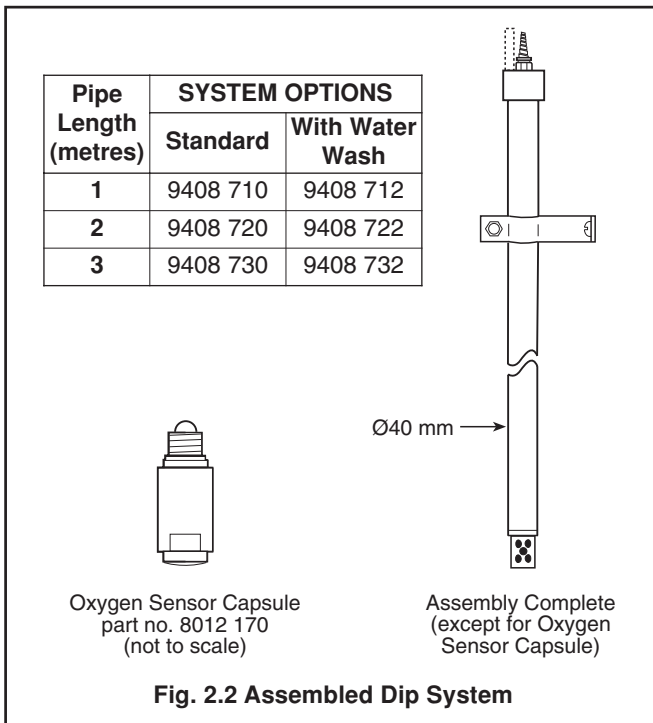

2.4 Submersible System – Fig. 2.4

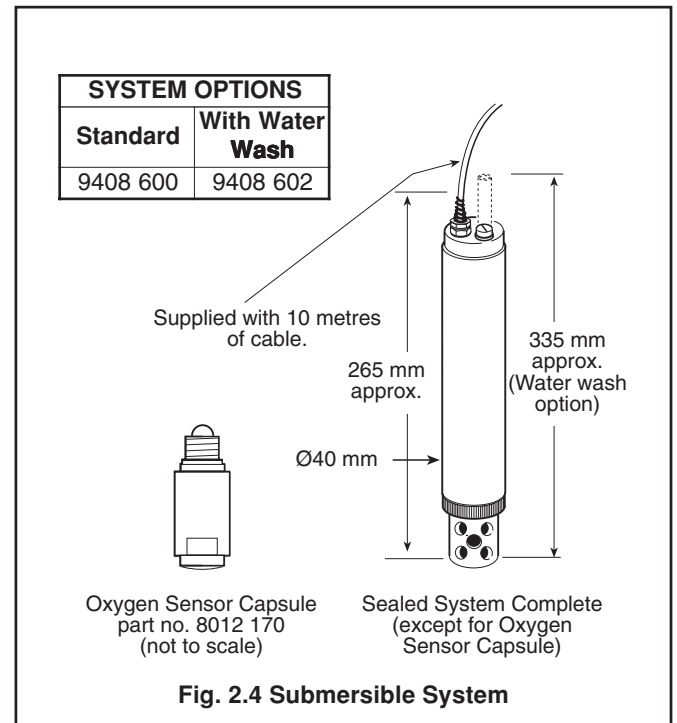

2.3.2 Kit Version – Fig. 2.3

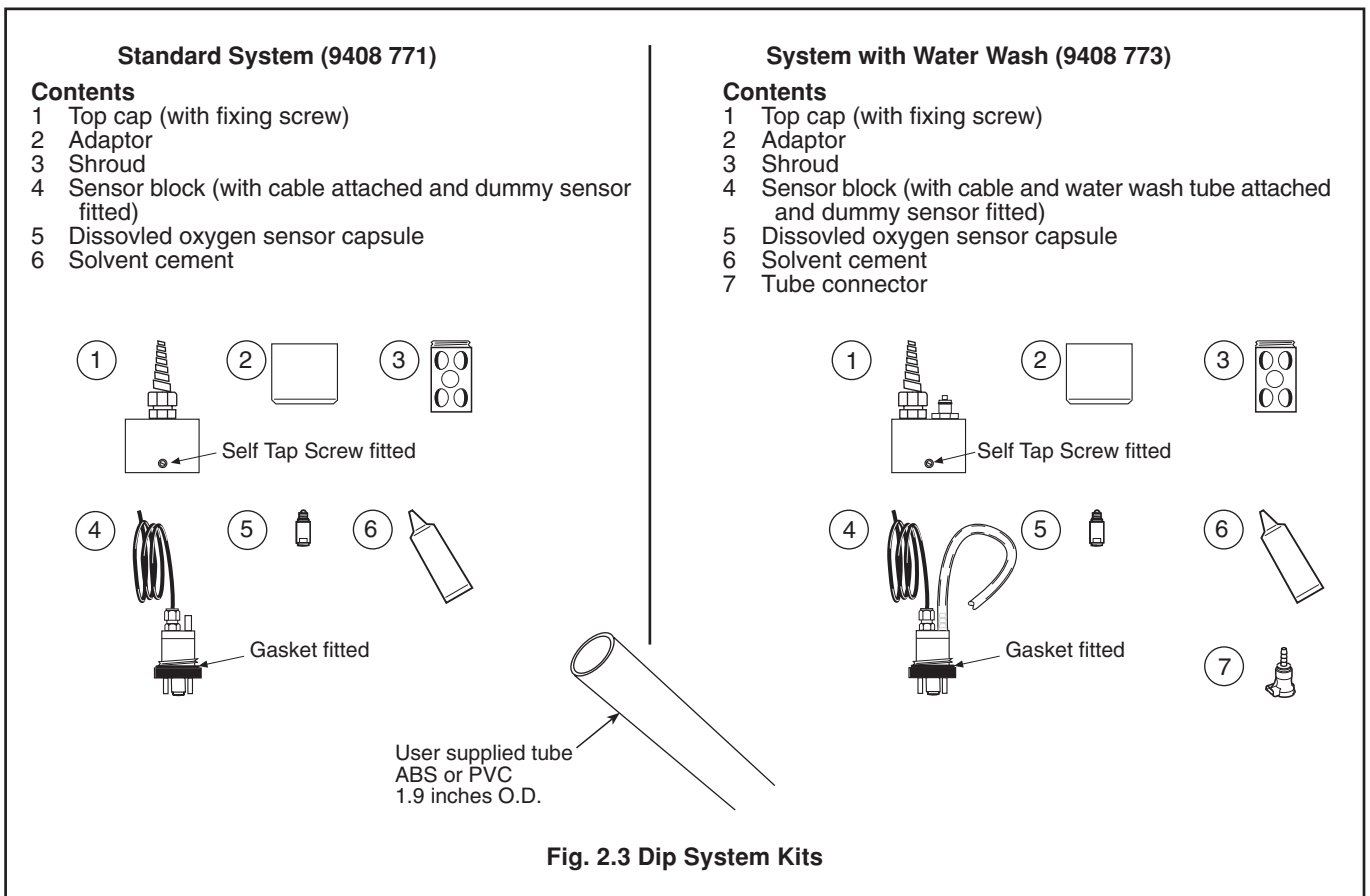

3 MECHANICAL INSTALLATION

3.1 Assembling Kit Systems

3.1.1 Floating Ball – Fig. 3.1

For installation of the assembled unit see Section 3.2.1 Floating Ball System.

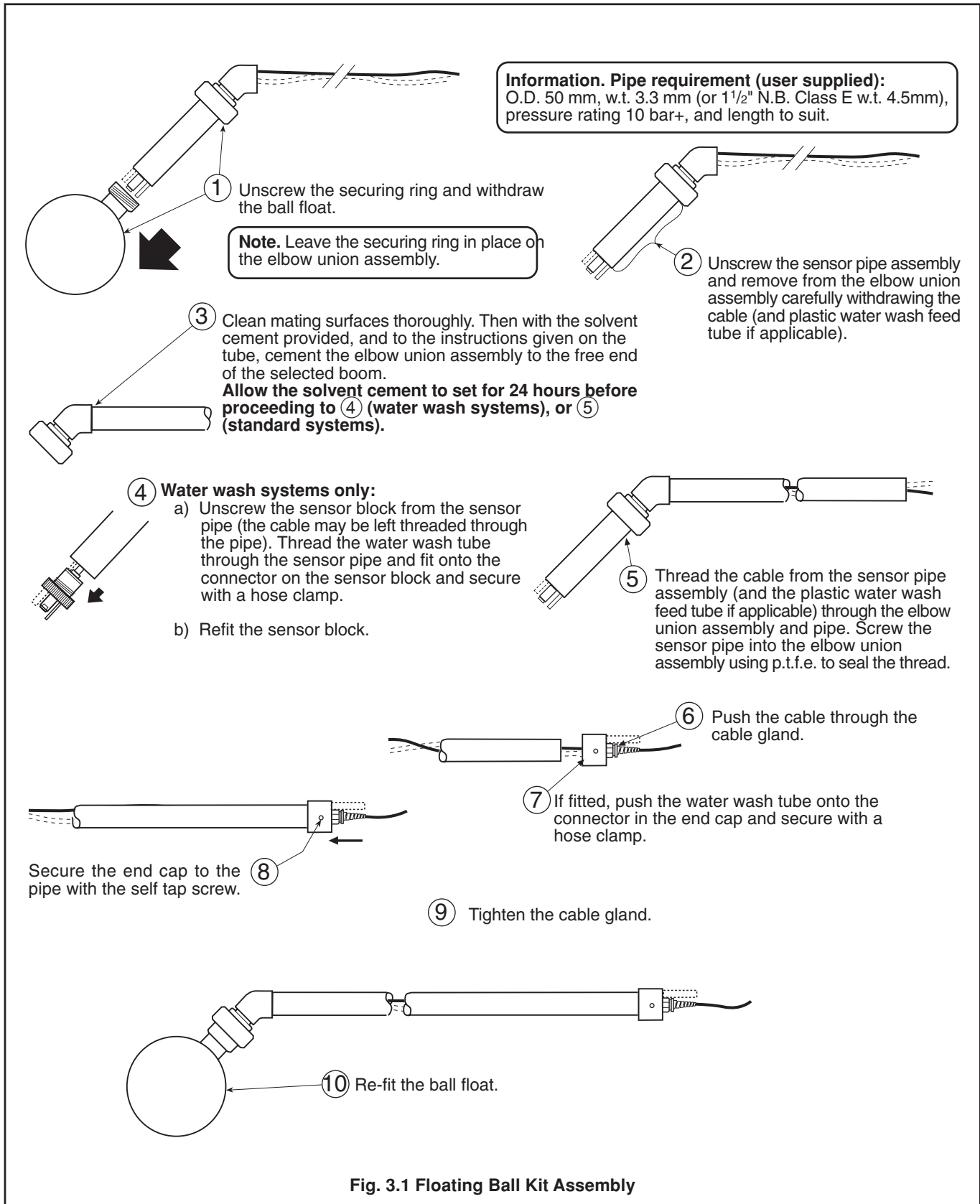

Fig. 3.1 Floating Ball Kit Assembly

3.1.2 Dip – Fig. 3.2

For installation of the assembled unit see Section 3.2.2 Dip Systems.

Information. Pipe requirement (user supplied):
O.D. 1.9", 1 1/2" N.B., pressure rating 10 bar+, and cut length to suit.

Note. There is no bracket supplied with this kit.

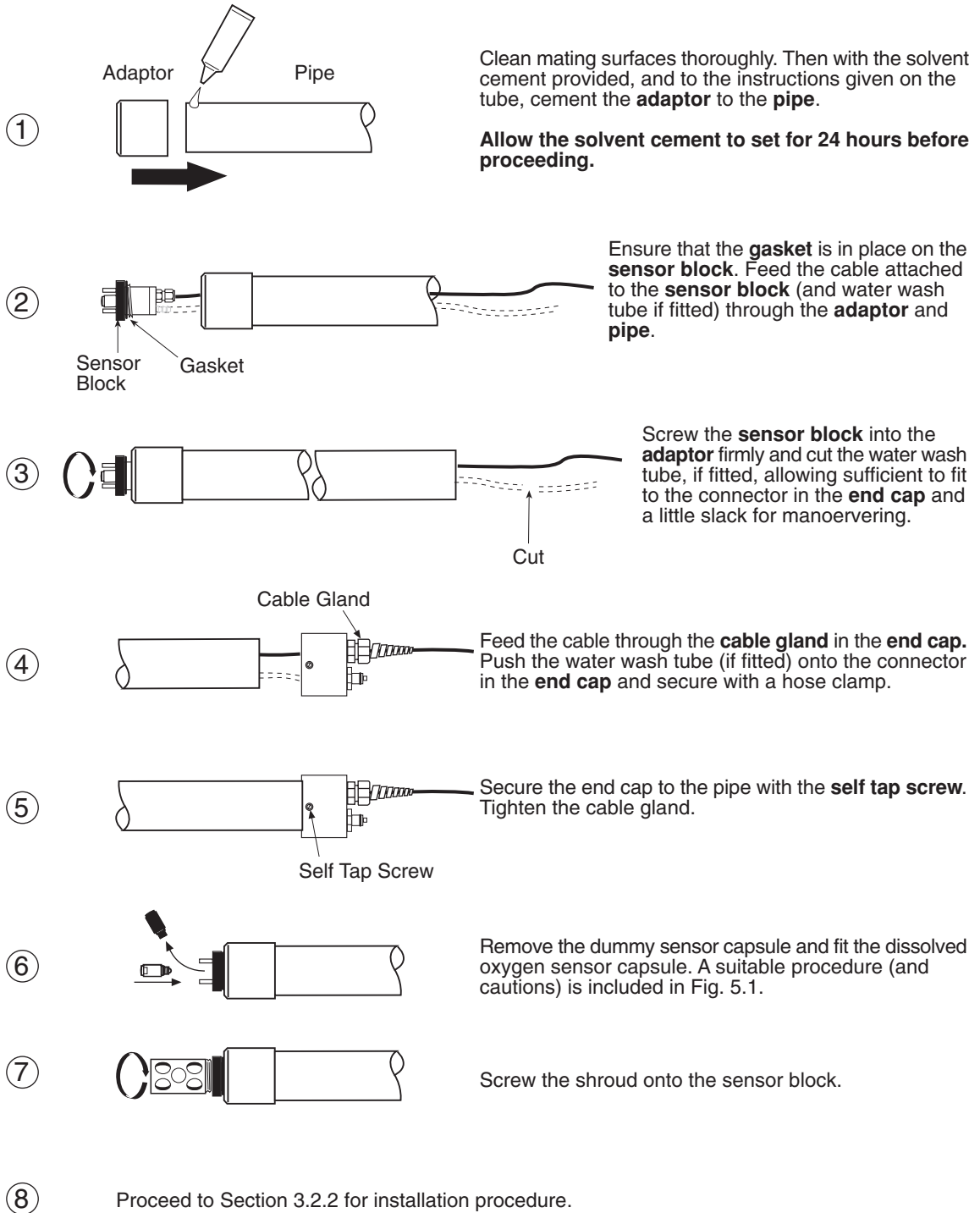

Fig. 3.2 Dip Kit Assembly

...3 MECHANICAL INSTALLATION

3.2 Installation

Caution. The system is supplied with the temperature probe and a dummy oxygen capsule fitted into the oxygen sensor body which is in the ball assembly. Before securing the boom to the handrail bracket, unscrew the dummy capsule from the end of the oxygen sensor body and fit the oxygen sensor capsule to the sensor body – see Section 5.1 **Replacing the Oxygen Sensor Capsule.**

The floating ball system is provided with pipe clamp fittings for handrail fixing. The installation should be arranged to ensure that when the boom is anchored to the rail, the sensor in the ball is fully covered by the liquid to be monitored.

3.2.1 Floating Ball System – Fig. 3.3

Select the position for the floating ball system on the handrail.

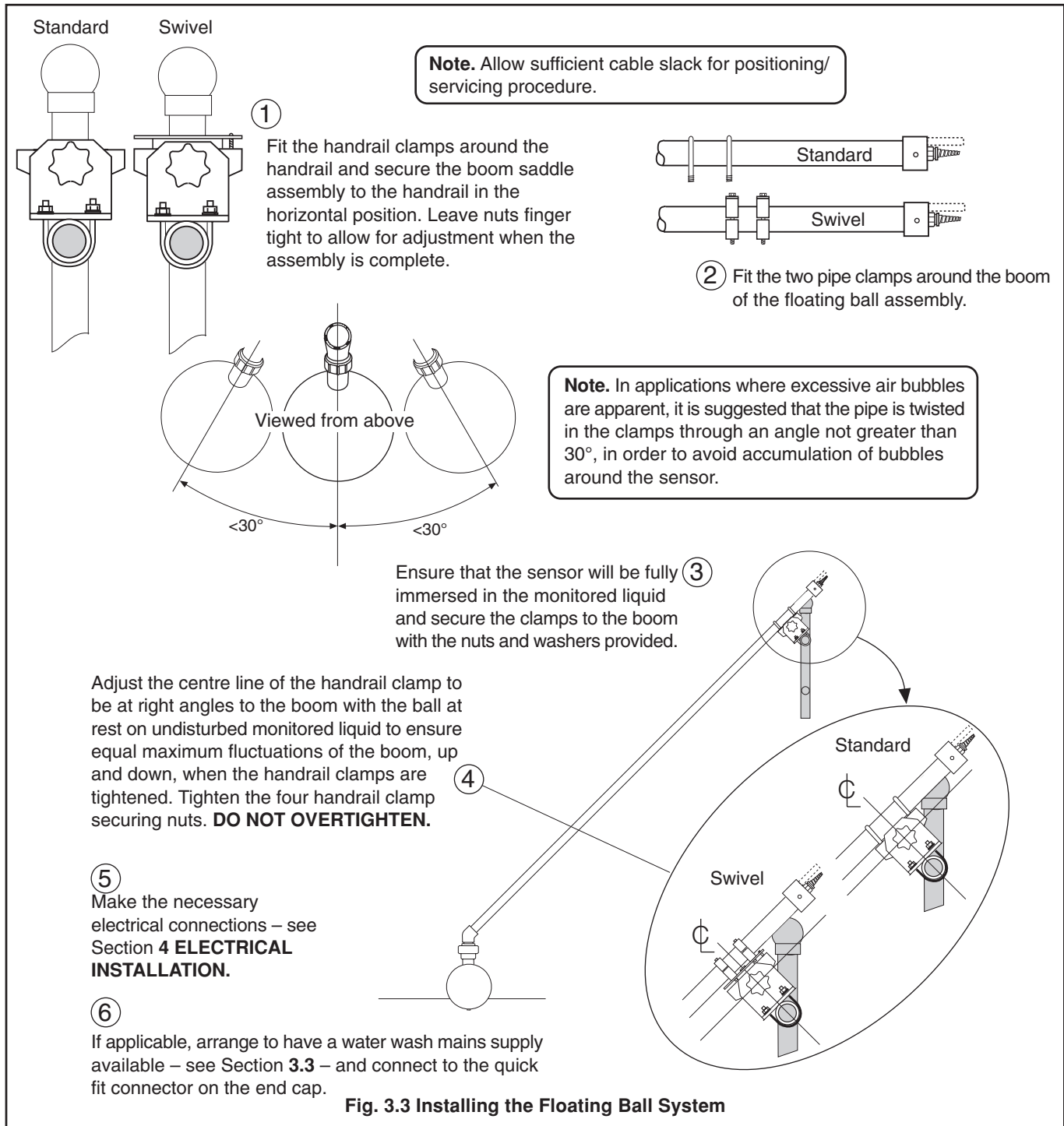

3.2.2 Dip Systems – Fig. 3.4

Note.

- The standard dip system is supplied with the temperature probe and oxygen sensor body fitted. Before fitting the dip tube to any bracket or fixing, remove the protective shroud, unscrew the dummy capsule from the end of the oxygen sensor body and fit the oxygen sensor capsule to the sensor body (see Section 5.1 Replacing the Oxygen Sensor Capsule) and replace the shroud. See section 3.1.2 for assembling dip kit systems.
- If the final mounting position of the dip system is inconvenient for wiring when fitted, wire the system prior to fixing – see Section 4 ELECTRICAL INSTALLATION.

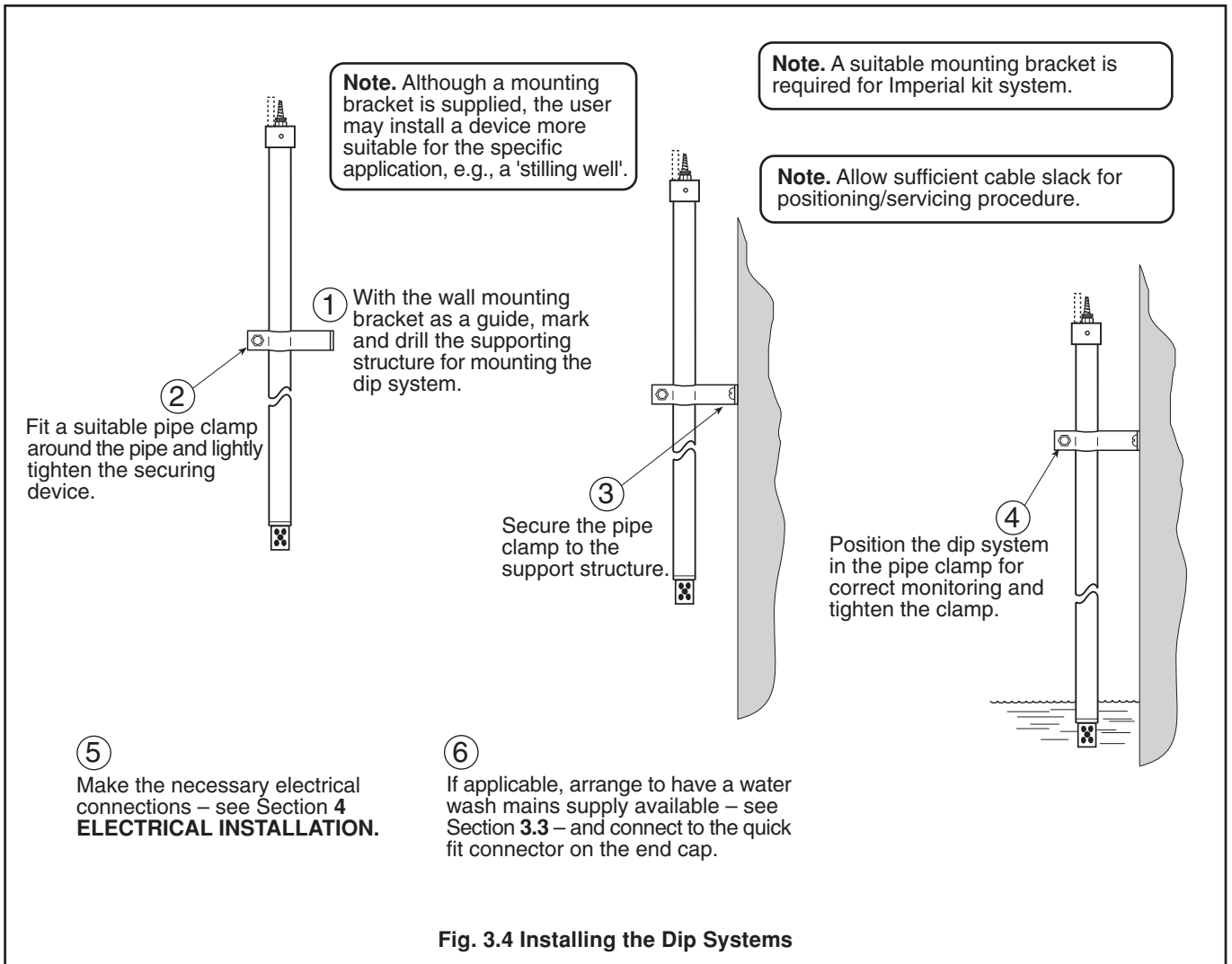

Fig. 3.4 Installing the Dip Systems

3.2.3 Submersible Systems – Fig. 3.5

Note. The submersible system is supplied with the temperature probe and oxygen sensor body fitted. Remove the protective shroud, unscrew the dummy capsule from the end of the oxygen sensor body and fit the oxygen sensor capsule to the sensor body (see Section 5.1 Replacing the Oxygen Sensor Capsule) and replace the shroud.

Note. The submersible system is provided with a screw fixing to enable it to be suspended on a small chain (not provided). This is to prevent cable strain and allows the system to be lowered to the required depth.



Fig. 3.5 Submersible Systems

...3 MECHANICAL INSTALLATION

3.3 Water Supply for Water Wash Systems – Fig. 3.6

Important Note. Installation must only be carried out in accordance with the local water authority and council bylaws.

Caution. The maximum water pressure at the electrode should not exceed 50 psi (4 bar). At NO time should the sample pressure be allowed to exceed that of the water wash water supply. Fit a non return valve if this possibility exists.

Information. As all quick-fit connectors used in Water Wash systems incorporate cutoff valves, tubes may subsequently be disconnected on operational equipment without sample loss or water wash discharge.

Note. For optimum performance of the Water Wash function in flow systems, the sample pressure should be at least 2 bars lower than that of the water wash water supply.

The water supply for the water wash system must come from a suitable supply via a solenoid valve. A general specification for the solenoid valve is:

Brass body: 2/2, NC
Orifice size: 3.0 / 4.0 mm
Port size: 1/4 in – 1/2 in BSP or NPT
Pressure: 0 to 6 bar
Coil: 24 V a.c., 110/115 V a.c. or
230/240 V a.c. 50/60 Hz

Note. See Fig. 3.6 for recommended tubing.

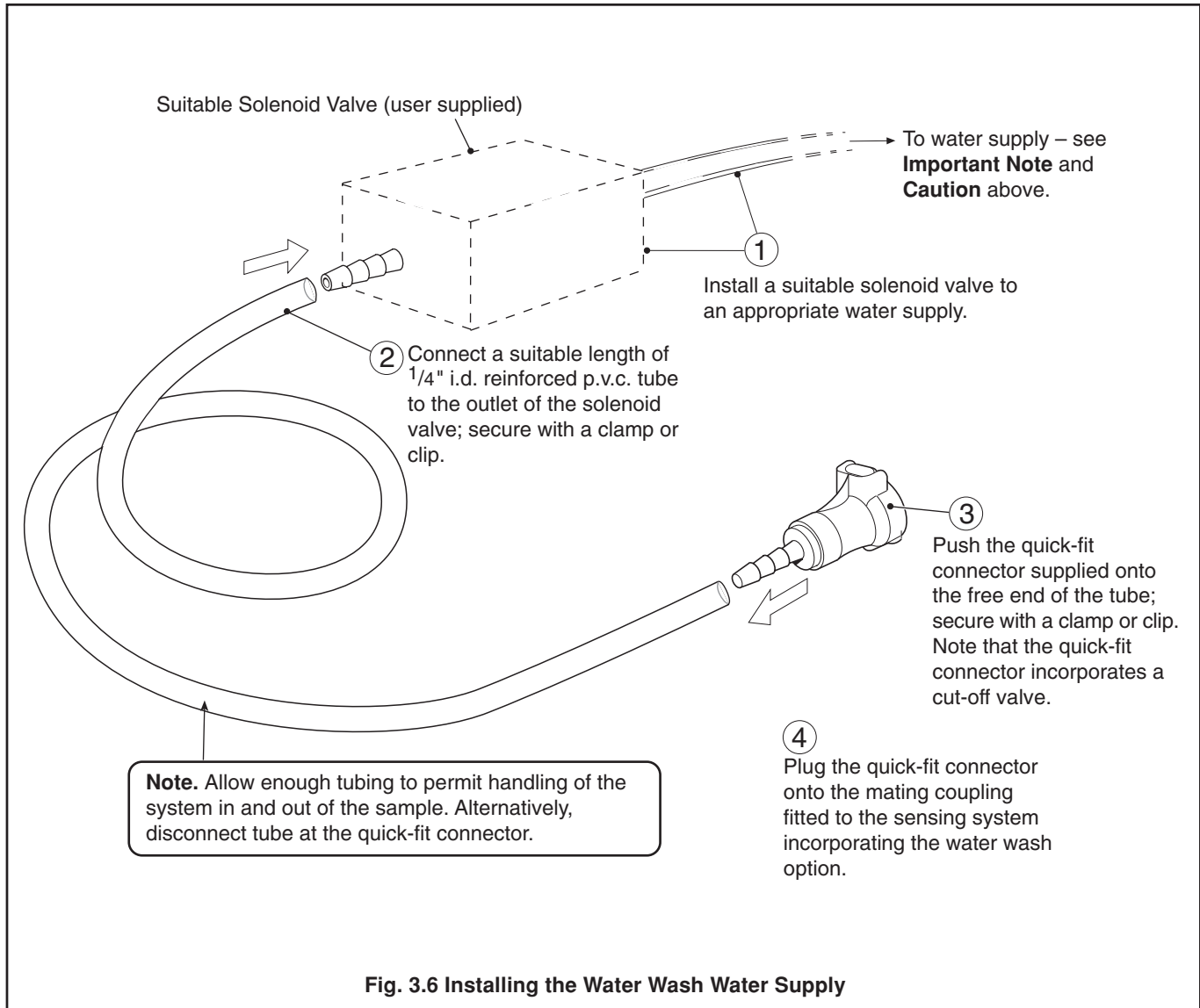

4 ELECTRICAL INSTALLATION

Caution. Cable should be of circular cross-section and of sufficient diameter to effect a seal inside the cable glands.

4.1 Connection to the Dissolved Oxygen Transmitter

Note. With floating ball and dip systems sufficient spare cable should be provided for manipulating the floating ball system if space is restricted when installing the interconnection cable between the floating ball and the transmitter.

Connect the cable (supplied permanently attached to the system) to the transmitter unit as detailed in the associated transmitter operating instructions, using the **terminal sleeve colors** to correspond with those in the operating instructions. For convenience, Tables 4.1 and 4.2 detail the connections to transmitters 4640 and 4645 respectively.

4640		
	Terminal No.	Wire
Sensor	1	+ve (Red)
	2	
	3	- ve (Blue)
	4	Screen
Temperature Compensator	5	Black
	6	Green
	7	Yellow

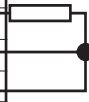

Table 4.1 Connections to the 4640 Dissolved Oxygen Transmitter

4645		
TBB		
	Terminal No.	Wire
Temperature Compensator	6	Yellow
	7	Green
	8	Black
Sensor	10	- ve (Blue)
	11	
	12	+ve (Red)

Connect the screen to the earth stud on the case.



Table 4.2 Connections to the 4645 Dissolved Oxygen Transmitter

4.2 Calibrating the Sensor – Fig. 4.1

The procedures for zero and span calibration are fully described in the 4600 Series Transmitter Unit Operating Instructions, to which reference should be made.

Note. It is advisable to switch off the water wash before starting the calibration procedure. This can be done either by turning off at the 4600 transmitter unit, or by disconnecting the quick-fit connector.

- 1) Remove the system from its mounting bracket.
- 2) If the system is a floating ball type, unscrew the securing collar and remove the ball – Fig. 4.1.
- 3) Carefully wash the exposed sensor capsule with clean water.
- 4) If the system is a floating ball type, fit the shroud, provided with the system, to protect the sensor capsule – Fig. 4.1.
- 5) Calibrate as instructed in the 4600 Series Operating Instructions.
- 6) If the system is a floating ball type, remove the protective shroud after calibration and replace the ball – Fig. 4.1.
- 7) Re-enable the water wash if applicable.

Regular maintenance is limited to periodic cleaning and calibration.

The sensor capsule is replaced whenever the existing one becomes exhausted – see Section 5.1 **Replacing the Oxygen Sensor Capsule**. Typical sensor life is approximately 12 months.

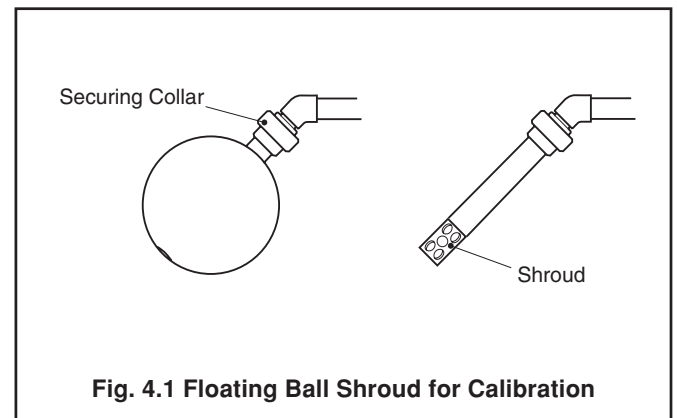

Fig. 4.1 Floating Ball Shroud for Calibration

5 MAINTENANCE

5.1 Replacing the Oxygen Sensor Capsule

Storage

- DO:**
- use sensors in date rotation to prevent them being stored longer than necessary.
 - at all times, store sensors in a dry and cool environment.
 - store sensors in a refrigerator to extend their life, but **DO NOT** allow them to freeze.
- DO NOT:**
- allow sensors to dry out, either in storage or in use.
 - leave sensors in vehicles where they are likely to freeze or be exposed to high temperatures.
 - leave sensors on-site without protection from direct sun or high temperatures.
 - use the sensor if it's sealed environment has dried out.

5.1.1 Floating Ball System – Fig. 5.1

Refer to Fig. 3.2 for information about accessing the floating ball. Use the necessary procedure steps in reverse order.

Notes.

- For systems fitted with the standard bracket the boom will have to be freed from the bracket clamp to access the floating ball.
- For systems fitted with a swivel bracket, when the boom is in the horizontal position, unscrew the swivel plate locking bolt sufficiently to release the swivel plate. Swing the boom so that the floating ball is accessible.

① Unscrew the securing ring whilst restraining the ball from turning.

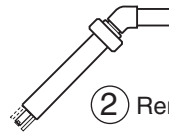
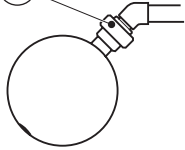

② Remove the ball from the sensor pipe.

Caution. Clean and dry the area around the sensor capsule before removal, as indicated below.

- ③ Use the capsule housing as a tool to unscrew the old capsule from the sensor block (see ⑩ for method); discard the old capsule in accordance with local regulations.
- ④ Dry the sensor block with a paper tissue; ensure that the gold electrical contacts, and the recess into which the capsule screws, are clean and completely dry.

Caution.

- Do not leave the new capsule exposed to air for more than 30 minutes as the membrane will dry out.
- Ensure the following steps are done carefully to avoid damaging the membrane covering the silver cathode.

⑤ Access the new capsule by unscrewing the capsule housing

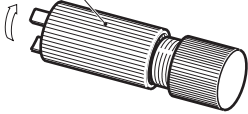

⑥ Unscrew the capsule from the shorting cap using the reverse end of the capsule housing as a tool.

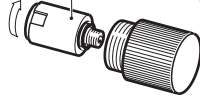

⑦ Remove and discard the rubber sealing ring from the new capsule.

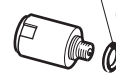

- ⑧ Dry the capsule with a paper tissue taking care not to damage the delicate, transparent membrane covering the silver cathode. Ensure that the gold contacts, and the threaded portion of the capsule are clean and completely dry.
- ⑨ Fit the new sealing ring supplied – see ⑦ above and screw the capsule into the sensor block by hand, firmly.

⑩ Reverse the capsule housing and locate the lugs into the keyways on top of the capsule. Then using the capsule housing as a tool, tighten the the sensor firmly by hand to ensure a good seal.

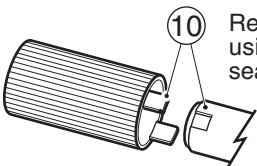

⑪ Calibrate the sensor - see Section 4.2 Calibrating the Sensor.

⑫ Align the holes in the end of the ball with the protruding sensor capsule and temperature compensator and replace the ball assembly over the sensor pipe. Ensure that an 'O' ring is in place in the union half.

⑬ Tighten the securing ring whilst restraining the ball from turning; rotation of the ball may damage the sensing end of the system.

Fig. 5.1 Replacing the Oxygen Sensor Capsule

5.1.2 Dip Systems

The procedure is identical to that for the Floating Ball System except that, in this case, it is only necessary to remove and replace the protective shroud instead of the ball. The shroud is removed from the end of the sensor block by unscrewing it.

5.1.3 Submersible Systems

The procedure is identical to that for the Dip System – see Section 5.1.2 **Dip Systems**.

5.2 Replacing the Oxygen Sensor Block

5.2.1 Floating Ball System – Fig. 5.2

- 1) To avoid damaging the sensor capsule dry around it then carefully remove it from the end of the sensor block and store safely. DO NOT touch the membrane.

Caution. Do not leave the capsule exposed to air for more than 30 minutes as the membrane will dry out.

- 2) Disconnect the cable from the dissolved oxygen transmitter (or junction box if applicable) and attach a draw wire of suitable length.
- 3) Slacken the cable gland on the end of the boom.

- 4) Remove the self tap screw and pull off the end cap.
- 5) Draw the cable through the gland.
- 6) Unscrew the securing ring of the ball float (whilst restraining the ball from turning) and withdraw the ball from the elbow union.
- 7) Carefully unscrew the sensor block from the end of the sensor pipe.
- 8) If fitted, disconnect the water wash feed tube from the sensor block.
- 9) Pull the cable through the boom, leaving sufficient draw wire at the end cap end to enable the replacement to be pulled through.
- 10) Disconnect the sensor block cable from the draw wire.
- 11) Attach the draw wire to the replacement sensor block cable and re-assemble in the reverse order of the previous steps.
- 12) Remove the dummy capsule from the replacement sensor block and carefully replace the sensor capsule into the sensor block.

5.2.2 Dip Systems

The procedure is identical to that for the floating ball system except that it is only necessary to remove and replace the protective shroud instead of the ball. Remove the shroud by unscrewing it.

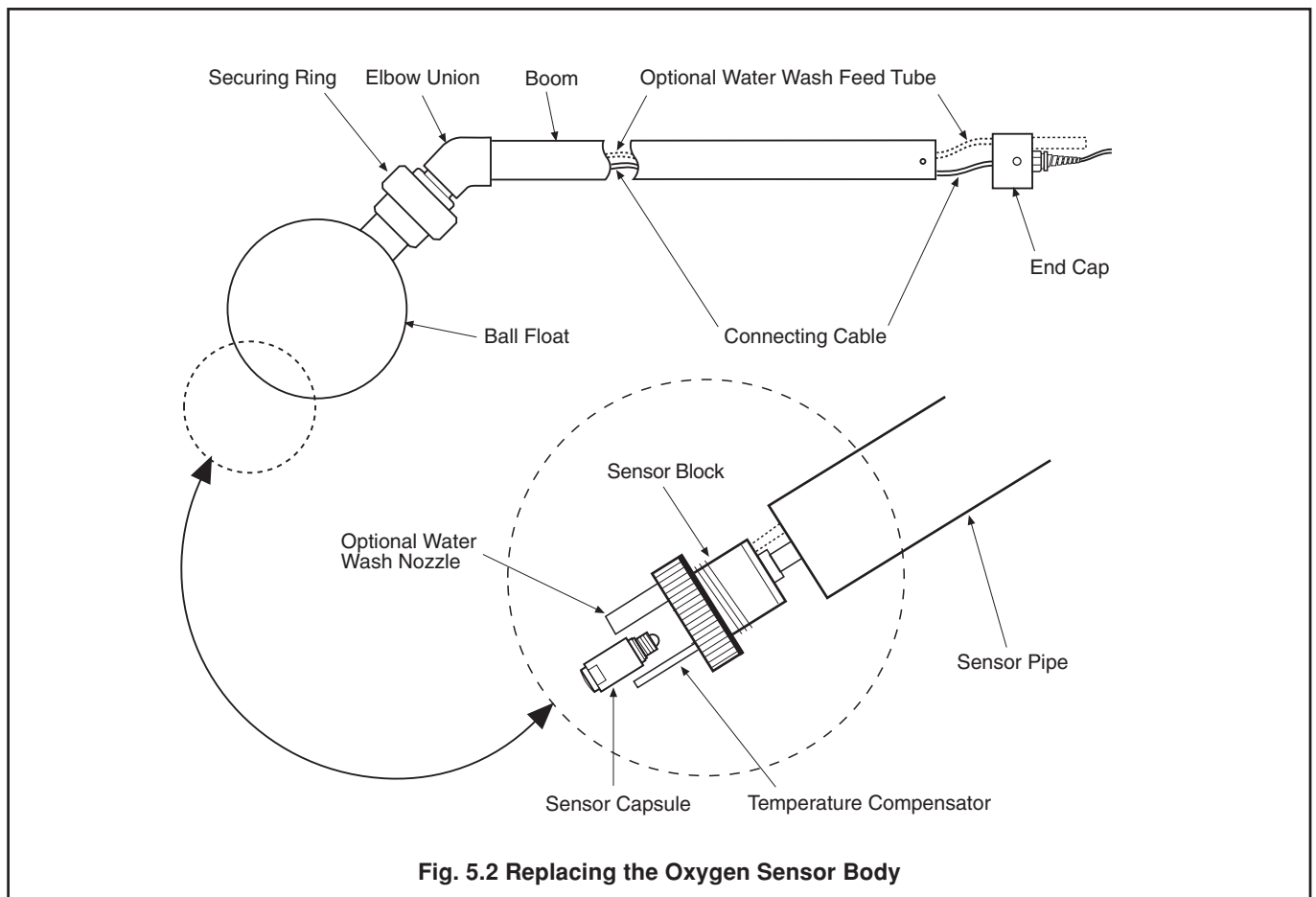

...5 MAINTENANCE

5.2.3 Submersible Systems

Submersibles are sealed systems and apart from sensor capsule replacement, no other maintenance is possible.

5.3 Changing the Temperature Compensator

5.3.1 Floating Ball and Dip Systems

This item is an integral part of the sensor body and is, therefore, not maintainable. Change the complete sensor body as described in Section 5.2.

5.3.2 Submersible System

The submersible system includes a sealed unit housing the combined temperature compensator/oxygen sensor body and is not accessible for maintenance purposes except for the replacement of the sensor capsule – see Section 5.1.3 Dip Systems.

6 SPECIFICATION

Sensor Type: 8012-170 sensor capsule.

Response:

Typically 20 seconds for 90% of a step change of oxygen concentration at 20°C.

Temperature Compensation:

Automatic correction by means of integral Pt 100 resistance thermometer.

Accuracy:

±0.2 mg l⁻¹ or ±2% saturation within ±10°C of the calibration temperature in the range 0 to 35°C.

Operating Temperature Range: 0 to 40°C

Operating Pressure: Atmospheric

Dimensions:

Floating Ball

Ball diameter: 203 mm

Boom, outside diameter: Metric - 50 mm
Imperial - 1⁷/₈ in (48 mm approximately)

Boom length

Assembled 3 metres

Kit 3 metres, user supplied

Dip

Dip Tubes:

Assembled (metric) 1,2 or 3 metre options
40 mm outside diameter

Kit (Imperial) user supplied
1.9 in outside diameter

Submersible

Diameter 40 mm

Length Approximately 265 mm
(335 mm with water wash)

Cable length 10 m

Materials of Construction:

Boom: ABS

Sensor body: ABS

Flotation ball: Polypropylene

Tube on dip system Polypropylene

Body of submersible system Polypropylene

Bracket metalwork Stainless steel

Extra Connection Cable:

Part No.: 0233-828

Maximum distance: 100 metres (328 feet)

7 SPARE PARTS LIST

7.1 Floating Ball System

Item No.	Description	Part No.	
1	Ball Float Assembly	9408 065	
2	Bracket Assemblies: Standard	Metric	9408 115
		Imperial	9408 116
		Metric	9408 135
		Imperial	9408 136
2A	Swivel		
3	Oxygen Capsule	8012 170	
4	Sensor Body:	Standard	9408 080
		With water wash	9408 081
5	Shroud	9408 026	
6	Gasket (Sensor Tube to Sensor Body)	9408 025	

Table 7.1 Floating Ball Spares List

Fig. 7.1 Floating Ball System

7.2 Dip System

Item No.	Description	Part No.	
1	Oxygen Capsule	8012 170	
2	Sensor Body:	Standard	9408 080
		With water wash	9408 081
3	Shroud	9408 026	
4	Gasket (Sensor Tube to Sensor Body)	9408 025	
5	Gasket (Shroud to Sensor Body)	9404 130	

Table 7.2 Dip Spares List

Fig. 7.2 Dip System

7.3 Submersible System

- Oxygen Capsule 8012 170
- Shroud 9408 026

APPENDIX A – SUPPORT BRACKET CONVERSION

A1 Kit Parts List – Fig. A.1

Table A.1 Contents of Conversion Kit

Item No.	Description	No. Off	Pt Nos
1	Boom clamps	4	Metric Kit 9408 135
2	Boom clamps ends	2	
3	Boom clamps bolts	4	
4	Shoulder screw	1	Imperial Kit 9408 136
5	Swivel plate	1	
6	Swivel plate locking screw	1	
7	Bearing washer	1	

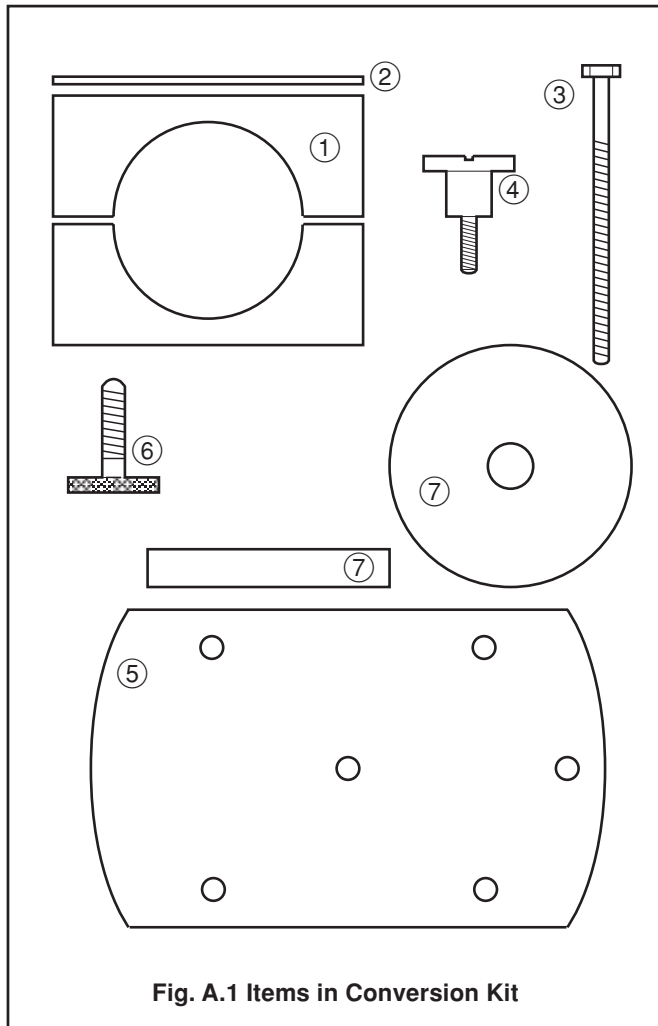

A2 Conversion Procedure – Fig. A.2

- 1) Discard the upper 'U' bolts from the standard bracket.
- 2) Assemble the items from the conversion kit shown in Table A.1 and Fig. A.1 on to the clamp base plate – see Fig. A.2.

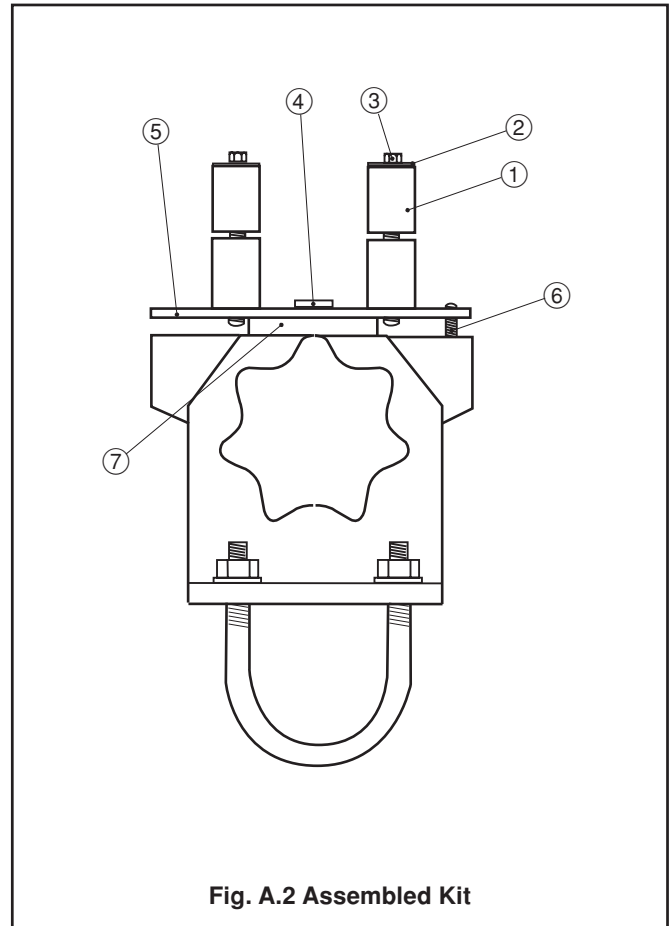

NOTES

PRODUCTS & CUSTOMER SUPPORT

Products

Automation Systems

- *for the following industries:*
 - Chemical & Pharmaceutical
 - Food & Beverage
 - Manufacturing
 - Metals and Minerals
 - Oil, Gas & Petrochemical
 - Pulp and Paper

Drives and Motors

- *AC and DC Drives, AC and DC Machines, AC motors to 1kV*
- *Drive systems*
- *Force Measurement*
- *Servo Drives*

Controllers & Recorders

- *Single and Multi-loop Controllers*
- *Circular Chart and Strip Chart Recorders*
- *Paperless Recorders*
- *Process Indicators*

Flexible Automation

- *Industrial Robots and Robot Systems*

Flow Measurement

- *Electromagnetic Flowmeters*
- *Mass Flow Meters*
- *Turbine Flowmeters*
- *Flow Elements*

Marine Systems & Turbochargers

- *Electrical Systems*
- *Marine Equipment*
- *Offshore Retrofit and Refurbishment*

Process Analytics

- *Process Gas Analysis*
- *Systems Integration*

Transmitters

- *Pressure*
- *Temperature*
- *Level*
- *Interface Modules*

Valves, Actuators and Positioners

- *Control Valves*
- *Actuators*
- *Positioners*

Water, Gas & Industrial Analytics Instrumentation

- *pH, conductivity, and dissolved oxygen transmitters and sensors*
- *ammonia, nitrate, phosphate, silica, sodium, chloride, fluoride, dissolved oxygen and hydrazine analyzers.*
- *Zirconia oxygen analyzers, katharometers, hydrogen purity and purge-gas monitors, thermal conductivity.*

Customer Support

We provide a comprehensive after sales service via a Worldwide Service Organization. Contact one of the following offices for details on your nearest Service and Repair Centre.

United Kingdom

ABB Limited
Tel: +44 (0)1453 826661
Fax: +44 (0)1453 829671

United States of America

ABB Inc.
Tel: +1 775 850 4800
Fax: +1 775 850 4808

Client Warranty

Prior to installation, the equipment referred to in this manual must be stored in a clean, dry environment, in accordance with the Company's published specification.

Periodic checks must be made on the equipment's condition. In the event of a failure under warranty, the following documentation must be provided as substantiation:

1. A listing evidencing process operation and alarm logs at time of failure.
2. Copies of all storage, installation, operating and maintenance records relating to the alleged faulty unit.

ABB has Sales & Customer Support
expertise in over 100 countries worldwide

www.abb.com

The Company's policy is one of continuous product
improvement and the right is reserved to modify the
information contained herein without notice.

Printed in UK (06.07)

© ABB 2007



ABB Limited
Oldends Lane, Stonehouse
Gloucestershire
GL10 3TA
UK
Tel: +44 (0)1453 826661
Fax: +44 (0)1453 829671

ABB Inc.
Analytical Instruments
9716 S. Virginia St., Ste. E
Reno, Nevada 89521
USA
Tel: +1 775 850 4800
Fax: +1 775 850 4808