

# AquaMaster 3 Electromagnetic flowmeter

The smart solution for  
remote applications



#### Widest flow range, highest accuracy

- reduced bore version measures minimal night flows and peak day flows
- full bore version for irrigation applications

#### OIML R49 and MID approved

- type approved to OIML R49 Class 1 and Class 2 and MID for any pipe orientation

#### Install in any location

- OIML R49 approved with zero diameter upstream and downstream straight pipe lengths

#### Backward-compatible

- comprehensive range of adaptors for connection to existing AquaMaster sensors

#### Sealed-for-life transmitter

- all input / outputs via external IP68 plug-and-socket connections

#### Optional integral multi-speed, multichannel, dual-variable logger

- high precision, high resolution datalogging

#### Logged data transmitted via SMS text message

- facilitates automated handling of logged data via GSM SMS

#### Battery, mains and renewable energy operation

- option of a 10-year battery life

## The next generation commercial water flowmeter

AquaMaster 3, available in sizes 15 to 600 mm (1/2 to 24 in.) with a reduced bore construction, is the total solution for flow measurement in the water industry. Outstanding performance, innovative features and user benefits, coupled with low cost of ownership ensures that AquaMaster 3 is the first choice for District Metering, Bulk Revenue, Trunk Mains and Treatment Works applications.

AquaMaster 3 is also available in sizes 25 to 300 mm (1 to 12 in.) in a full-bore construction where zero pressure loss is essential, such as irrigation applications.

AquaMaster has been designed specifically for the water industry in response to its stringent demands for enhanced metering capability; enabling ever more efficient and cost-effective operation and compliance with increasing legislative requirements.

Based on our proven technology, AquaMaster 3 is supported by the expertise of ABB – the world's leading flowmeter manufacturer with many pioneering advances in water flow metering over the last decade – for example AquaMag™, MagMaster™, AquaProbe™, WaterMaster™ and CalMaster™. ABB operates nationally- and internationally-accredited flow calibration facilities in the UK, USA, Germany, Australia and India. We also offer comprehensive, locally-based before- and after-sales support and service.

In addition to high measurement performance, AquaMaster 3 offers totalizer readings via the industry-standard inductive pad reader.

## Typical applications

- Bulk revenue
- District metering
- Trunk mains
- Treatment works
- Irrigation



*AquaMaster 3 system*

AquaMaster 3 is a new design of mains, renewable energy and battery-powered transmitter for the AquaMaster range of flowmeters. It has a stainless steel housing with a thermoplastic outer and the assembly is sealed-for-life to IP68 as standard. The transmitter incorporates plug & socket connections for all inputs and outputs.

## Transmitter

- Comprehensive display
- Rated IP68 (NEMA 6P) for submerged use in flooded chambers
- Resettable or secure totals
- 8 mm (0.31 in.) high displays for Totals (exceeds ISO 4064 requirements)
- All connections via plug & socket
- Tamper-resistant and MID approved
- 3 outputs (forward and reverse pulse, or pulses, direction and alarm)

The AquaMaster 3 transmitter provides the most comprehensive range of flow data and information currently available to the water industry. If all the data is not required, the transmitter can be configured so that only the required values are displayed, ensuring simple reading with no superfluous data.

The transmitter can be mounted directly onto the AquaMaster sensor (close-coupled) or remotely from it. For close-coupled meters, the mounting system positions the display so that it is visible from both the top and the side. The AquaMaster 3's program memory (or firmware) uses reprogrammable flash memory technology that has been enhanced to enable this firmware to be upgraded in the field via a local serial port connection. This future-proofs AquaMaster 3, making enhancements or new features available to installed units.

The AquaMaster 3 transmitter can contain an optional multi-speed, multi-channel, dual-variable logger. The ability of the logger to run at two speeds simultaneously enables the user to investigate, in precise detail, flow and pressure activity during a period of interest. The logger records both flow and pressure via direct digital data transfer, ensuring optimum accuracy and measurement resolution. Traditional techniques of counting pulses over a short logging interval leads to 'quantization' effects corresponding to whole numbers of pulses on logger graphs. AquaMaster 3 eliminates such effects, averaging digitally over the selected logging interval. Such high resolution data facilitates step testing, leak detection and water network analysis.

The AquaMaster's internal loggers feature an advanced automatic time synchronization facility that ensures operation on synchronized time boundaries, irrespective of what logging interval is set. This ensures all flow and pressure data, when combined with data from other meters, is synchronized precisely.

For revenue application, not only is flow and pressure information available; there are also totalizer and tariff loggers, that log all volume totals (forward, reverse, net) and tariff readings totals daily at midnight. The in-built memory of 732 days keeps all records for 2 years. The readings stored are the precise register volumes and are not inferred by pulse integration or other similar techniques.

Access to the loggers and logger configuration is security-protected by user-definable passwords.

### Remote access via mobile phone technology

- Remote access to logger data over Quad band GSM network by SMS text message
- Remote configuration, status monitoring and preventive maintenance
- Diagnostics and configuration, via standard GSM mobile phone
- Automated metering data reporting via SMS text
- SMS data accessible via industry-standard SMS Gateways capable of exporting data using Windows DDE, OLE, XML etc.

## Transmitter power options

### Mains power with super capacitor back-up

- Mains-only option supplied with a built-in rechargeable super capacitor backup power source
- The super capacitor can operate for up to 5 days without power (depending on operating conditions)
- The super capacitor has recharge cycles greater than 10,000 and with mains power offers continuous SMS operation
- In the event of mains interruption, continuous measurement is maintained and alarms reported via SMS protocols for up to 5 days without power
- No batteries to replace

### Battery power for remote locations

- Up to 10-year\* battery life
- Option of 3D, 6D or 9D cells for external lithium battery packs for high temperature locations
- Option of manganese alkaline battery pack\*
- Site-replaceable battery pack
- The battery can be replaced without loss of logger contents enabling smooth switchover

\*Operation at extremes of temperature can significantly shorten battery capacity and life.

AquaMaster 3 is the ideal solution for locations where there is no external power.

### Solar and wind power

Utilizes a simple DC (6 to 12 V) connection from sources as small as a 5 W solar panel / wind generator. Wind generators and solar panels are not supplied by ABB.

- No external rechargeable batteries required
- No external regulators
- Very simple installation
- Super capacitor backup

It is now possible to access sun and wind energy power sources. The internal super capacitor can power the transmitter at night or for up to 3 weeks during power interruptions (dependent on operational conditions).

## Tariff feature

AquaMaster 3 incorporates a multiple tariff feature where the accumulated flow volume is routed to one of two 8-digit signed tariffs; tariff A or tariff B, depending on time and date. This feature is fully-programmable by the user for time-of-day, day-of-week or date during the year. These user-defined times / days / dates can be combined in a variety of modes to produce the tariff regimes illustrated in the tables below.

### Weekly cycle defined

Mode	Tariff A	Tariff B
1	Day time during weekend	Night time at weekend + day and night during week
2	Day time during week	Night time during week + day and night during weekend
3	All day times	All night times
4	Night time during weekend	Day time during weekend + day and night during week
5	Day and night during weekend	Day and night during week
6	Day time during weekend + night time during weekend	Night time during week + day time during weekend
7	All day times + night time during weekend	Night time during week

### Yearly cycle defined

Mode	Tariff A	Tariff B
1	Day time during summer	Night time during summer + day and night during winter
2	Day time during winter	Night time during winter + day and night during summer
3	All day times	All night times
4	Night time during summer	Day time during summer + day and night during winter
5	Day and night during summer	Day and night during winter
6	Day time during winter + night time during summer	Night time during winter + day time during summer
7	All day times + night time during summer	Night time during winter

**Easy, low-cost installation**

No matter what the location or installation requirements, AquaMaster 3 provides a cost-effective solution. Both the sensor and the transmitter are fully submersible, enabling installation in flooded chambers. In addition, the sensor is buriable, eliminating the need for a chamber.

Installation merely involves excavating to the pipeline, fitting the sensor and back-filling the hole, ensuring very fast, low-cost installation. The associated transmitter is then located in the most convenient position for the user. The elimination of bypasses and ancillary items such as strainers, enables the installation cost to be kept to an absolute minimum.

Installation requirement of zero pipe diameters (OD) upstream and downstream for the reduced bore version removes concern over where to install a sensor, while delivering the highest performance. These factors, together with the innovative 'Fit and Flow™' system, ensure foolproof installation with total user confidence.

**Fit and flow**

- No need to match sensor and transmitter
- Fast, reliable installation
- Foolproof, no errors
- Sensor stores all calibration factors, site settings and serial numbers
- Volume totalizer and tariff values backed-up in sensor for total security
- Multiple, programmable password levels stored for measurement security

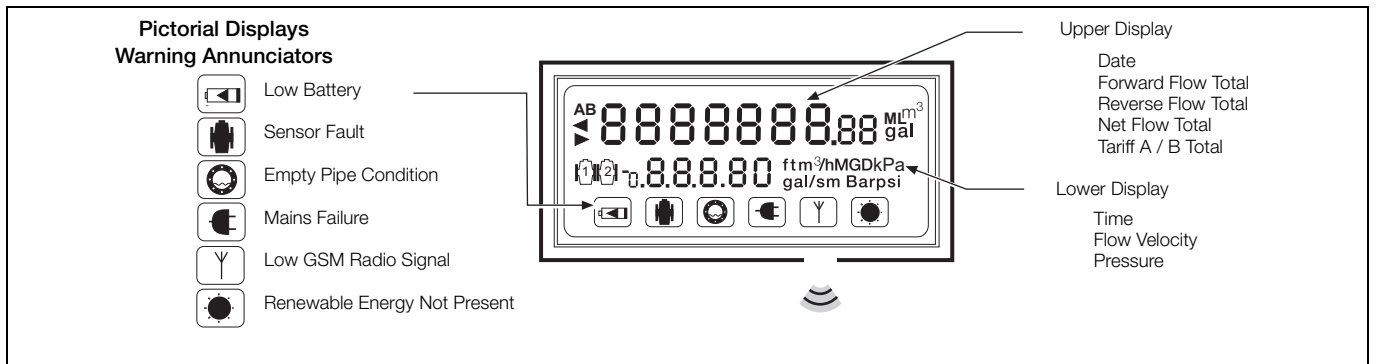

AquaMaster 3 Display

## New performance standards for flow measurement

With the widest flow range, optimum accuracy and long term stable calibration, AquaMaster 3 sets new performance standards in the water industry.

The reduced bore (MM/GA) performance is OIML R49 type approved (DN40 to DN300) to the latest Class 1 and Class 2 accuracies with a tighter accuracy above  $Q_{0.5}$  % and  $Q_{0.25}$  % (Fig. 1).

This unique low flow rate capability enables previously unrecordable minimal night flow rates to be metered; particularly important for bulk revenue and district metering applications.

The clear bore of the AquaMaster 3 eliminates the possibility of damage by particulate matter and the absence of moving and wearing components ensures that this unique level of performance is maintained long term.

The unique design of the AquaMaster 3 sensor conditions the flow profile in the measuring section so that distortions in the flow profile, either upstream or downstream, are flattened. The result is excellent in situ meter performance, even with very bad hydraulic installation conditions.

Hydraulic disturbance tests conducted during OIML R49 type approval confirmed a guaranteed accuracy to Class 1 and Class 2, even with flow disturbers bolted directly on the meter, either upstream or downstream at zero pipe diameters.

AquaMaster 3 reduced bore version has been type examined and conforms to EU Measuring Instrument Directive (MID).

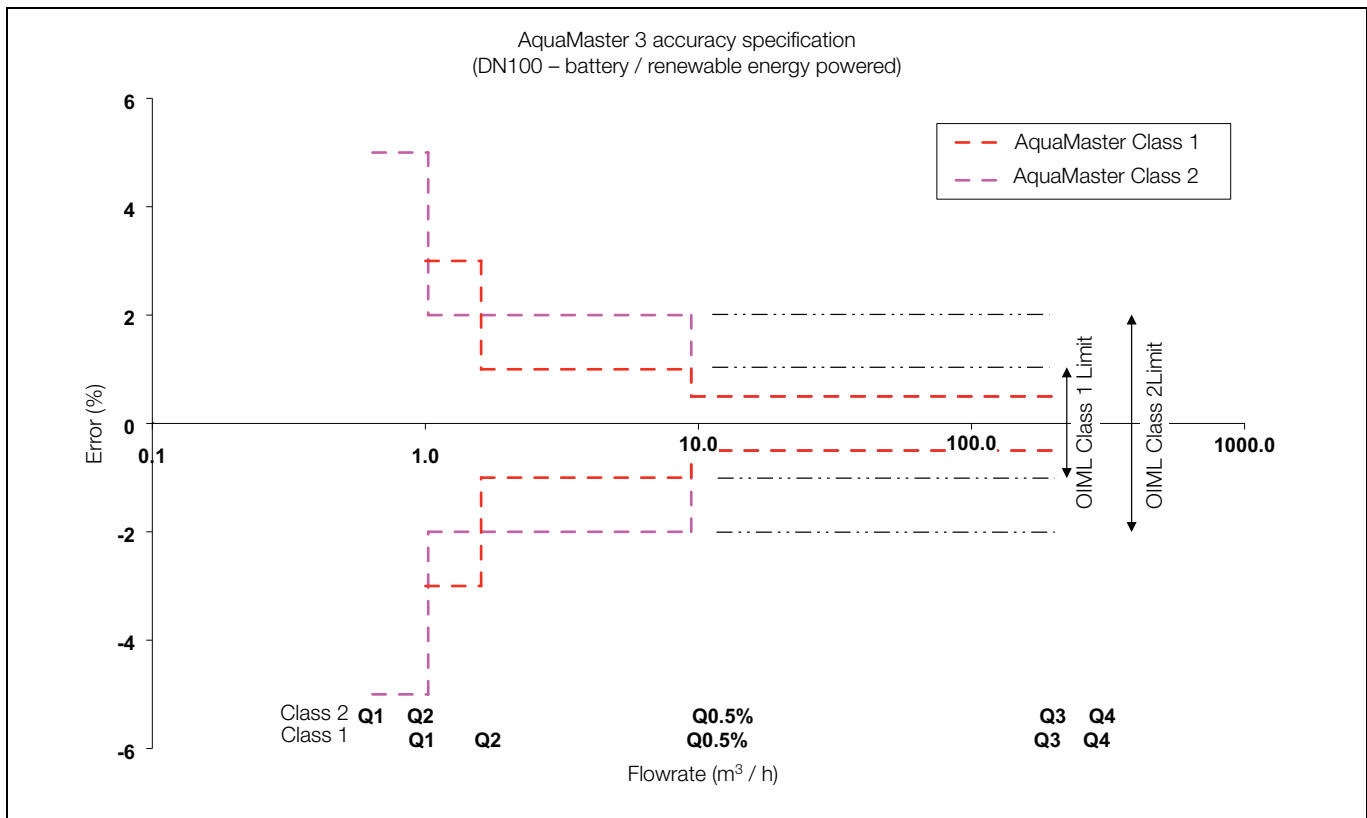

AquaMaster 3 specification to OIML R49

## Specification – flowmeter

### Battery- or renewable energy-powered reduced bore meters – flow specifications

Size		OIML Class 2 specification					OIML Class 1 specification			
		Q <sub>4</sub>	Q <sub>3</sub>	Q <sub>(0.5%)</sub>	Q <sub>2</sub>	Q <sub>1</sub>	R	Q <sub>2</sub>	Q <sub>1</sub>	R
mm	in.	m <sup>3</sup> / h (Ugal / min)	m <sup>3</sup> / h (Ugal / min)	m <sup>3</sup> / h (Ugal / min)	m <sup>3</sup> / h (Ugal / min)	m <sup>3</sup> / h (Ugal / min)		m <sup>3</sup> / h (Ugal / min)	m <sup>3</sup> / h (Ugal / min)	
15	1/2	5 (22)	4 (18)	0.24 (1.05)	0.026 (0.110)	0.016 (0.070)	250	0.04 (0.176)	0.025 (0.11)	160
20	3/4	7.9 (34.8)	6.3 (28)	0.37 (1.62)	0.04 (0.176)	0.025 (0.110)	250	0.063 (0.277)	0.04 (0.176)	160
25	1	12.5 (55)	10 (44)	0.6 (2.64)	0.064 (0.281)	0.04 (0.176)	250	0.1 (0.44)	0.063 (0.277)	160
40*	1 1/2	31 (138)	25 (110)	1.5 (6.6)	0.16 (0.704)	0.1 (0.44)	250	0.25 (1.10)	0.16 (0.704)	160
50*	2	50 (220)	40 (176)	2.4 (10.56)	0.26 (1.14)	0.16 (0.70)	250	0.4 (1.76)	0.25 (1.10)	160
65	2 1/2	79 (347)	63 (277)	3.7 (16.29)	0.40 (1.76)	0.25 (1.10)	250	0.63 (2.77)	0.4 (1.76)	160
80*	3	125 (550)	100 (440)	5.9 (25.97)	0.64 (2.81)	0.4 (1.76)	250	1 (4.40)	0.63 (2.77)	160
100*	4	200 (880)	160 (700)	9.4 (41.38)	1.0 (4.4)	0.64 (2.81)	250	1.6 (7.04)	1 (4.40)	160
125	5	200 (880)	160 (700)	9.4 (41.38)	1.0 (4.4)	0.64 (2.81)	250	1.6 (7.04)	1 (4.40)	160
150*	6	500 (2200)	400 (1760)	23.5 (103.46)	2.56 (11.27)	1.6 (7.04)	250	4 (17.61)	2.5 (11)	160
200*	8	788 (3470)	630 (2770)	37 (162.90)	4.0 (17.61)	2.5 (8.8)	250	6.3 (27.73)	3.9 (17.17)	160
250*	10	1250 (5500)	1000 (4400)	60 (260)	6.4 (28.18)	4 (17.6)	250	10 (44)	6.3 (27.73)	160
300*	12	2000 (8810)	1600 (7040)	90 (400)	10.2 (44.91)	6.4 (28.18)	250	16 (70.44)	10 (44)	160
350	14	2000 (8810)	1600 (7040)	110 (484.3)	16 (70.44)	10 (44.02)	160	41 (180.5)	25 (110)	63
400	16	3125 (13760)	2500 (11010)	170 (748.48)	25 (110)	15.6 (68.68)	160	63 (277.4)	40 (176)	63
450	18	3125 (13760)	2500 (11007)	170 (748.48)	25 (110)	15.6 (68.68)	160	63 (277.4)	40 (176)	63
500	20	5000 (22010)	4000 (17610)	270 (1188.72)	40 (176.11)	25 (110)	160	100 (440.3)	63.5 (279.6)	63
600	24	7875 (34670)	6300 (27740)	420 (1849.20)	63 (277.38)	39 (171.71)	160	160 (704.4)	100 (440.3)	63

\* OIML R49 version available to Class 1 and Class 2

**Note.** OIML R49–1 allows Class 1 only for meters with Q<sub>3</sub> ≥ 100 m<sup>3</sup> / h. Meters outside this range were tested to Class 1 accuracy and passed.

### Battery- or renewable energy-powered full bore meters – flow specifications

DN	Class 2 specification					R
	Q <sub>4</sub>	Q <sub>3</sub>	Q <sub>(0.5%)</sub>	Q <sub>2</sub>	Q <sub>1</sub>	
	m <sup>3</sup> / h (Ugal / min)	m <sup>3</sup> / h (Ugal / min)	m <sup>3</sup> / h (Ugal / min)	m <sup>3</sup> / h (Ugal / min)	m <sup>3</sup> / h (Ugal / min)	
25	20 (88)	16 (70)	1.1 (4.83)	0.16 (0.70)	0.10 (0.44)	160
40	50 (220)	40 (176)	2.7 (11.9)	0.4 (1.76)	0.25 (1.10)	160
50	79 (348)	63 (277)	4.2 (18.5)	0.63 (2.77)	0.4 (1.76)	160
65	125 (550)	100 (440)	6.7 (29.5)	1.0 (4.40)	0.63 (2.77)	160
80	200 (880)	160 (704)	10.7 (47.1)	1.6 (7.04)	1.0 (4.40)	160
100	313 (1378)	250 (1100)	16.7 (73.5)	2.5 (11.00)	1.6 (7.04)	160
150	788 (3469)	630 (2733)	42 (184.9)	6.3 (27.73)	3.9 (17.2)	160
200	1,250 (5503)	1,000(4402)	67 (294.9)	10.0 (44.02)	6.3 (27.73)	160
250	2,000 (8805)	1,600 (7044)	107 (471.1)	16.0 (70.44)	10 (44.02)	160
300	3,125 (13759)	2,500 (11007)	167 (735.3)	25.0 (110.07)	15.6 (68.68)	160

## AC-powered reduced bore meters – flow specifications

Size		OIML Class 2 specification						OIML Class 1 specification		
		Q <sub>4</sub>	Q <sub>3</sub>	Q <sub>(0.25%)</sub>	Q <sub>2</sub>	Q <sub>1</sub>	R	Q <sub>2</sub>	Q <sub>1</sub>	R
mm	in.	m <sup>3</sup> / h (Ugal / min)	m <sup>3</sup> / h (Ugal / min)	m <sup>3</sup> / h (Ugal / min)	m <sup>3</sup> / h (Ugal / min)	m <sup>3</sup> / h (Ugal / min)		m <sup>3</sup> / h (Ugal / min)	m <sup>3</sup> / h (Ugal / min)	
15	1/2	5 (22)	4 (18)	0.11 (0.48)	0.010 (0.044)	0.006 (0.026)	630	0.016 (0.070)	0.010 (0.04)	400
20	3/4	7.9 (35)	6.3 (28)	0.18 (0.79)	0.016 (0.070)	0.010 (0.044)	630	0.025 (0.11)	0.016 (0.070)	400
25	1	12.5 (55)	10 (44)	0.29 (1.27)	0.025 (0.11)	0.016 (0.070)	630	0.04 (0.176)	0.025 (0.11)	400
40*	1 1/2	31 (138)	25 (110)	1.5 (6.6)	0.063 (0.28)	0.040 (0.176)	630	0.1 (0.44)	0.063 (0.28)	400
50*	2	50 (220)	40 (176)	1.5 (6.6)	0.1 (0.44)	0.063 (0.277)	630	0.16 (0.70)	0.1 (0.44)	400
65	2 1/2	79 (247)	63 (277)	1.8 (6.2)	0.16 (0.7)	0.1 (0.44)	630	0.25 (1.10)	0.16 (0.70)	400
80*	3	125 (550)	100 (440)	3 (13.2)	0.3 (1.32)	0.16 (0.70)	630	0.4 (1.76)	0.25 (1.10)	400
100*	4	200 (880)	160 (700)	4.6 (20.25)	0.41 (1.8)	0.25 (1.10)	630	0.64 (2.82)	0.4 (1.76)	400
125	5	200 (880)	160 (700)	4.6 (20.25)	0.41 (1.8)	0.25 (1.10)	630	0.64 (2.82)	0.4 (1.76)	400
150*	6	500 (2200)	400 (1760)	11.4 (50.19)	1 (4)	0.63 (12.77)	630	1.6 (7.04)	1.0 (4.40)	400
200*	8	788 (3470)	630 (2770)	18 (79.25)	1.6 (7)	1.0 (4.40)	630	2.5 (11)	1.6 (7.04)	400
250*	10	1250 (5500)	1000 (4400)	29 (127.7)	2.5 (11)	1.6 (7.04)	630	4 (17.6)	2.5 (11)	400
300*	12	2000 (8810)	1600 (7040)	46 (202)	4.1 (18)	2.5 (11)	630	6.4 (28.18)	4 (17.6)	400
350	14	2000 (8810)	1600 (7040)	80 (352)	6.4 (28.18)	4 (17.6)	400	12.8 (56.35)	8 (35.22)	200
400	16	3125 (13760)	2500 (11007)	125 (550)	10 (44)	6.3 (27.73)	400	20 (88.05)	12.5 (55.03)	200
450	18	3125 (13760)	2500 (11007)	125 (550)	10 (44)	6.3 (27.73)	400	20 (88.05)	12.5 (55.03)	200
500	20	5000 (22010)	4000 (17610)	200 (880)	16 (70.44)	10 (44)	400	32 (140.9)	20 (88.05)	200
600	24	7875 (34760)	6300 (27740)	315 (1387)	25.2 (110.9)	15.8 (69.56)	400	50.4 (221.9)	31.5 (138.7)	200

\* OIML R49 version available to Class 1 and Class 2

**Note.** OIML R49–1 allow Class 1 only for meters with Q<sub>3</sub> ≥ 100 m<sup>3</sup> / h. Meters outside this range were tested to Class 1 accuracy and passed.

## AC-powered full bore meters – flow specifications

DN	Class 2 specification					
	Q <sub>4</sub>	Q <sub>3</sub>	Q <sub>(0.25%)</sub>	Q <sub>2</sub>	Q <sub>1</sub>	R
	m <sup>3</sup> / h (Ugal / min)	m <sup>3</sup> / h (Ugal / min)	m <sup>3</sup> / h (Ugal / min)	m <sup>3</sup> / h (Ugal / min)	m <sup>3</sup> / h (Ugal / min)	
25	20 (88)	16 (70)	1.6 (7)	0.08 (0.35)	0.05 (0.22)	315
40	50 (220)	40 (176)	4 (17.6)	0.2 (0.88)	0.13 (0.57)	315
50	79 (348)	63 (277)	6.3 (27.7)	0.32 (1.41)	0.20 (0.88)	315
65	125 (550)	100 (440)	10 (44)	0.5 (2.20)	0.32 (1.41)	315
80	200 (880)	160 (704)	16 (70.4)	0.81 (3.56)	0.51 (2.24)	315
100	313 (1378)	250 (1100)	25 (110)	1.3 (5.72)	0.79 (3.47)	315
150	788 (3469)	630 (2733)	63 (277)	3.2 (14.09)	2.0 (8.80)	315
200	1,250 (5503)	1,000(4402)	100 (440)	5.1 (22.45)	3.2 (14.09)	315
250	2,000 (8805)	1,600 (7044)	160 (704)	8.1 (35.66)	5.1 (22.45)	315
300	3,125 (13759)	2,500 (11007)	250 (1100)	12.7 (55.91)	7.9 (34.78)	315

## Specification – sensor

### Wetted materials

#### Screw-end meters

Brass and stainless steel 316L

#### Flanged meters

Electrodes – stainless steel 316L

### Potable water approvals

	WRAS Listed	NSF Approved	ACS
MM/GA	✓	Pending	DN40 to 300, excluding DN65 and 125
MM/GF	✓	✓	x

### Pressure limitations

As flange rating

PN25 Max Process Temp 50 °C (122 °F)

PN40 Max Process Temp 40 °C (104 °F)

OIML / MID Approved Meters 16 bar (232 psi)

### Pressure equipment directive 97/23/EC

This product is applicable in networks for the supply, distribution and discharge of water and associated equipment and is therefore exempt.

### Environmental Protection

Rating

IP68 (NEMA 6P) to 10 m (33 ft.)

Buriable (sensor only) to 5 m (16 ft.)

### Conductivity

>50 µS/cm

### End connections

#### Thread-end connections (MM/GA)

15 mm – ISO 228 G 3/4 in. B 3/4 in. NPSM

20 mm – ISO 228 G 1 in. B 1 in. NPSM

25 mm – ISO 228 G 1 1/4 in. B 1 1/4 in. NPSM

#### 40 to 300 mm (1.5 to 12 in.) flanged (MM/GA)

EN1092-1 / ISO 7005 – PN10, PN16

ANSI B16.5 Class 150

AS 2129 Tables C, D, E and F

AS 4087 PN14, PN16, PN21

JIS to BS2210, 10k

#### 350 to 600 mm (14 to 24 in.) flanged (MM/GA)

EN1092-1 / ISO 7005 – PN10, PN16

AS 4087 PN14, PN16, PN21

AS 2129 Tables C, D

JIS to B2210 5k and 10k

#### 25 to 300 mm (1 to 12 in.) flanged (MM/GF)

EN1092-1 / ISO 7005 – PN10, PN16

ANSI B16.5 Class 150

AS 4087, PN16

### OIML R49 approval (MM/GA only)

#### Size range and flow specification

See specification table

#### Accuracy class

1 and 2

#### Environmental class

T50 0.1 °C to 50 °C (32.18 °F to 122 °F)

#### Pressure loss class

< 0.63 bar

#### Minimum upstream pipe

0 D

#### Minimum downstream pipe

0 D

#### Orientation

Any

#### MID Approval

Approved to directive 2004/22/EC

## Specification – transmitter

### AquaMaster 3 transmitter

#### Mounting

Directly on sensor

or

Remote up to 200 m (650 ft)

#### Housing

IP68 (NEMA 6P)

Stainless steel housing in a thermoplastic outer cover with window, encapsulated with polyurethane-based resin.

#### Electrical connections

IP68 plug and socket, mains cable

#### Sensor cable

ABB cable supplied as standard

SWA cable available (via adaptor box) on application

#### Mains supply

85 to 265 V AC @ <3 VA

Connection cable: approx. 3 m (10 ft.)

Mains power failure backup time: approx. 5 days

#### Renewable power

Solar or wind

Input voltage: 6 to 22 V DC @ <5 W

**Note.** Renewable energy generators do not operate at maximum capacity, for example, low wind speed, coating of the solar panel, short daylight periods. As a consequence some installations will require generators with a capacity greater than the specified 5 W minimum.

Max. current: 200 mA

Backup power time up to 3 weeks  
(dependent on operating conditions)

#### External battery pack

IP68 (NEMA 6P)

Manganese alkaline battery life: 0 to 45 °C (32 to 113 °F)  
typically 5 years

Lithium battery pack life: 0 to 60 °C (140 °F) typically 10 years

Battery life is shorter with GSM, depending on how frequently it is used and for what period. For example, used once per day for SMS automated reporting of data logged at 15 minute intervals, the life of a battery pack would be typically reduced by 20 %.

#### Backup power time

Approximately 1 minute

#### Pulse and alarm outputs

Three bidirectional solid state switches with common isolation

±35 V DC 50mA

Output 1 forward only or forward plus reverse pulses

Output 2 reverse pulses or direction indicator

Output 3 alarm indicates any problem with measurement or with power

Pulse output 50 Hz maximum, 50 % nominal duty cycle

#### Communications options

Serial data communications

Local Port RS232

**Note.** On battery and renewable energy versions frequent use of the RS232 port considerably reduces battery / standby life.

RS485 MODBUS

MODBUS RTU slave

Baud rates: 1200, 2400, 4800, 9600 or 19200

RS485: 2-wire + ground signalling

Low power shut-off mode after 10 s of inactivity

## Encoder interface (non-logging versions only)

### Function

Remote reading of totalizer and serial no.

### Protocol

ABB encoder

### Connections

2-wire for inductive pads (max. cable length 80 m [260 ft.])

3-wire for AMR

### Compatible readers

Severn Trent Services Smart reader

ABB or Elster SR100 and SR50

Logicon Versaprobe

Itron ERT

### Compatible inductive pads

Starpad

ABB

### Telemetry applications (option)

#### GSM / SMS modem

Mounting:

Internal

Frequency bands:

Quad band: 850 / 900 / 1800 / 1900 MHz

Functions:

SMS auto report of flow and optionally, pressure logger data (typically 1 s or 1 min. average)

SMS report frequency: typically daily

SMS alarm reporting at time of event, for example power loss, limited to 1 per day

SMS flowmeter configuration

SMS flowmeter diagnosis

SMS total / tariff auto report

#### GSM antenna (option)

Quad band operation:

850 / 900 / 1800 / 1900 MHz

Mounting:

Integral with transmitter or remote.

Antenna environmental:

IP66 (NEMA4) waterproof for accidental submersion

**Note.** The GSM does not operate with integral antenna under water.

General advice is to mount the antenna as high as possible, always outside of any metal enclosure and not under the surface of the ground.

## Pressure system – external transducer (option)

### Pressure range

16 bar Abs.

### Connection

Standard quick-fit male probe connector via an adapter cable

### Operating temperature range

-20 (ambient) to 70 °C (-4 to 158 °F)

Protect the sample and transducer from freezing.

### Accuracy (typical)

±0.4 % of range

### Thermal error band (typically 100 °C [212 °F])

±1.5 % span

### Cable length

5 or 10 m (16 or 33 ft)

## Temperature ranges

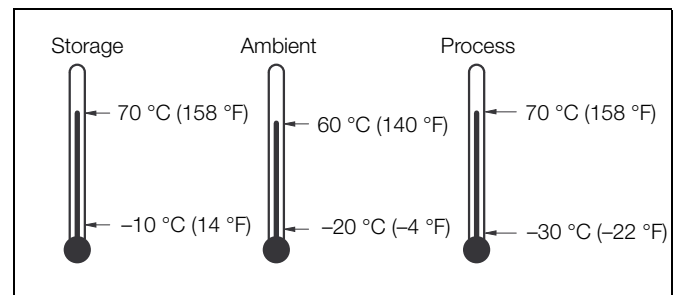

Operation outside ambient temperature limits of 0 to 45 °C (32 to 113 °F) reduces battery capacity and shortens battery life.

### Response time (programmable)

#### Minimum

1 s (mains-powered)

15 s (battery-powered + external renewable energy)

### Device languages

English

French

German

Spanish

Italian

Dutch

### Mounting

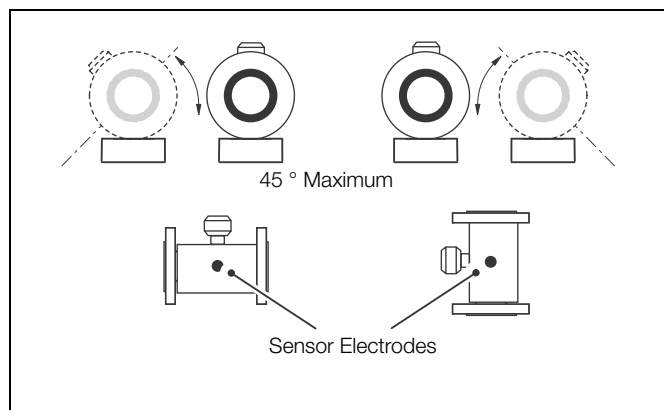

### Pipe conditions

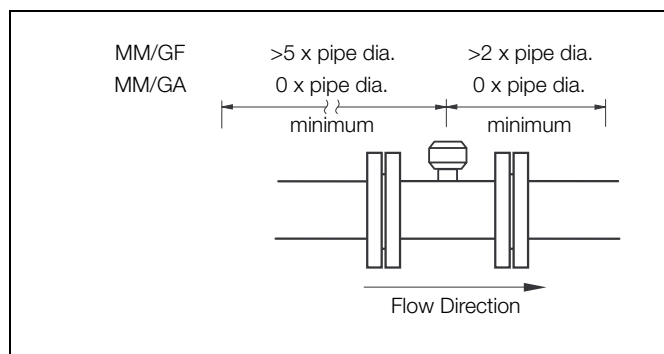

### Pressure loss (MM/GA only)

Flow Rate	Pressure Loss in bar (psi)
$Q_3$	<0.63 (9.1)
$Q^3 / 2$	<0.16 (2.3)

### Logger details (option)

Logger Function	Logger		
	1	2	3
Flow & Pressure	Flow & Pressure	Flow & Pressure	Forward, Reverse, Tariffs & Net Flow Totals
No. of Records	8831	11361	732
Logging Interval	15 to 65500 s (adjustable)		24 hr (fixed)
Typical Capacity	3 months @15 min	7 days (approx.) @ 1 min	2 year

### Software availability

Software	Direct RS232	SMS (Text)
ABB LogMaster	✓	✗
Technolog (PMAC)	✓	✗
Primayer Primeware	✓	✗
OSI PI Database or Capula	✓	✗
Hydreka (Winfluid)	✓	✗
Mobile phone text	✗	✓
AutoChart	✗	✓
Areal (Tokapi)	✗	✓
ABB Logger Server	✗	✓
EcoTech	✗	✓
Q Tech	✗	✓

**Sensor specification (nominal dimensions)**

**15 to 25 mm (1/2 to 1 in.) – screw ends (MM/GA)**

Meter Size		Dimensions mm (in.)		Approx. Weight	
mm	in.	A	Connection	kg	lb
15	1/2	119 (4.7)	G 3/4 in. B or 3/4 in. NPSM	2.5	5
20	3/4	127 (5)	G 1 in. B or 1 in. NPSM	2.5	5
25	1	127 (5)	G 1 1/4 in. B or 1 1/4 in. NPSM	2.5	5

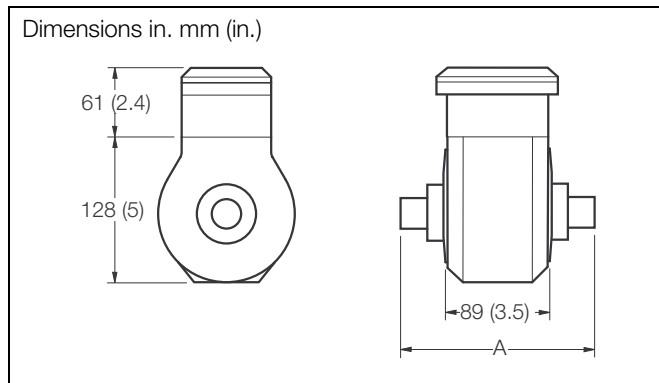

**350 to 600 mm (14 to 24 in.) – flanged (MM/GA)**

Meter Size		Dimensions mm (in.)			Approx. Weight	
mm	in.	A	B	C	kg	lb
350	14	513 (20.2)	520 (20.5)	550 (21.7)	100	220
400	16	570 (22.4)	576 (22.7)	600 (23.6)	115	253
450	18	632 (24.9)	627 (24.7)	698 (27.5)	160	352
500	20	686 (27.0)	679 (26.7)	768 (30.2)	217	455
600	24	772 (30.4)	770 (30.3)	918 (36.1)	315	693

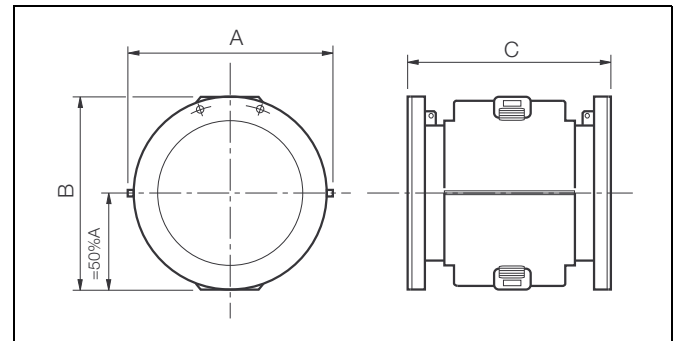

**40 to 300 mm (1 1/2 to 12 in.) – flanged (MM/GA)**

Meter Size		Dimensions mm (in.)		Approx. Weight	
mm	in.	A	B	kg	lb
40	1 1/2	150 (5.9)	200 (7.9)	11	24
50	2	165 (6.5)	200 (7.9)	12	27
65	2 1/2	219 (8.6)	200 (7.9)	13	29
80	3	200 (7.9)	200 (7.9)	18	40
100	4	220 (8.6)	250 (9.8)	25	55
125	4	220 (8.6)	250 (9.8)	25	55
150	6	285 (11.2)	300 (11.8)	31	68
200	8	340 (13.3)	350 (13.8)	48	106
250	10	405 (15.9)	450 (17.7)	75	165
300	12	460 (18.1)	500 (19.7)	112	247

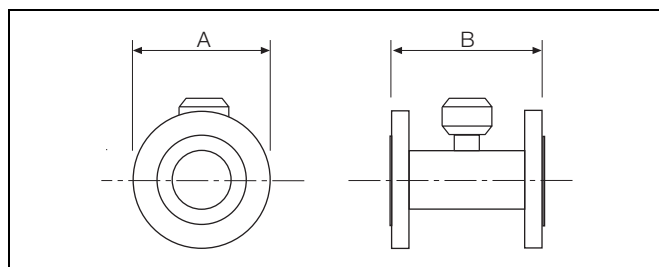

**25 to 300 mm (1 to 12 in.) – full bore (MM/GF)**

Meter Size		Dimensions mm (in.)		Approx. Weight	
mm	in.	A	B	kg	lb
25	1	115 (4.5)	200 (7.9)	7	15
40	1 1/2	150 (5.9)	200 (7.9)	9	20
50	2	165 (6.5)	200 (7.9)	10	23
65	2 1/2	185 (7.3)	200 (7.9)	18	40
80	3	200 (7.9)	200 (7.9)	18	40
100	4	230 (9.0)	250 (9.8)	24	54
150	6	285 (11.2)	300 (11.8)	38	84
200	8	345 (13.6)	350 (13.8)	37	81
250	10	410 (16.1)	450 (17.7)	60	132
300	12	485 (19.1)	500 (19.7)	70	154

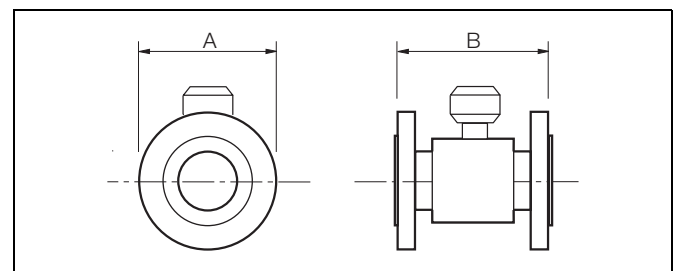

### Overall dimensions

#### AquaMaster 3

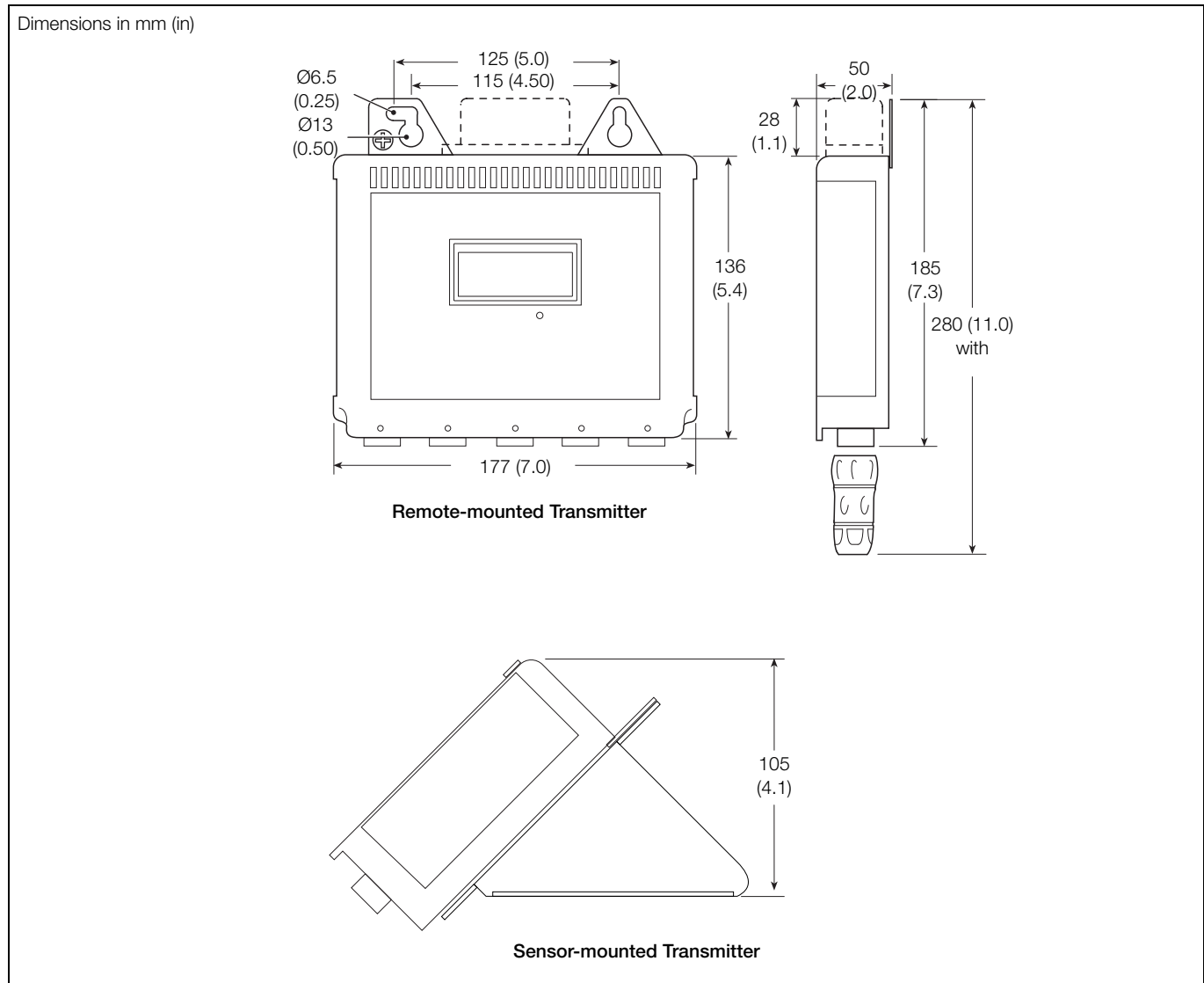

Transmitter dimensions

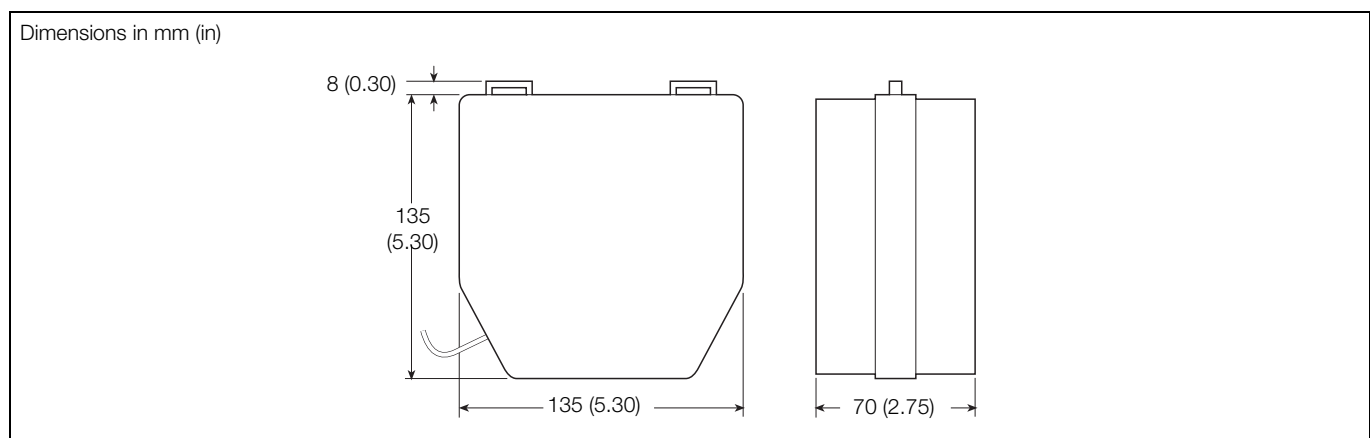

Battery pack dimensions

Electrical connections

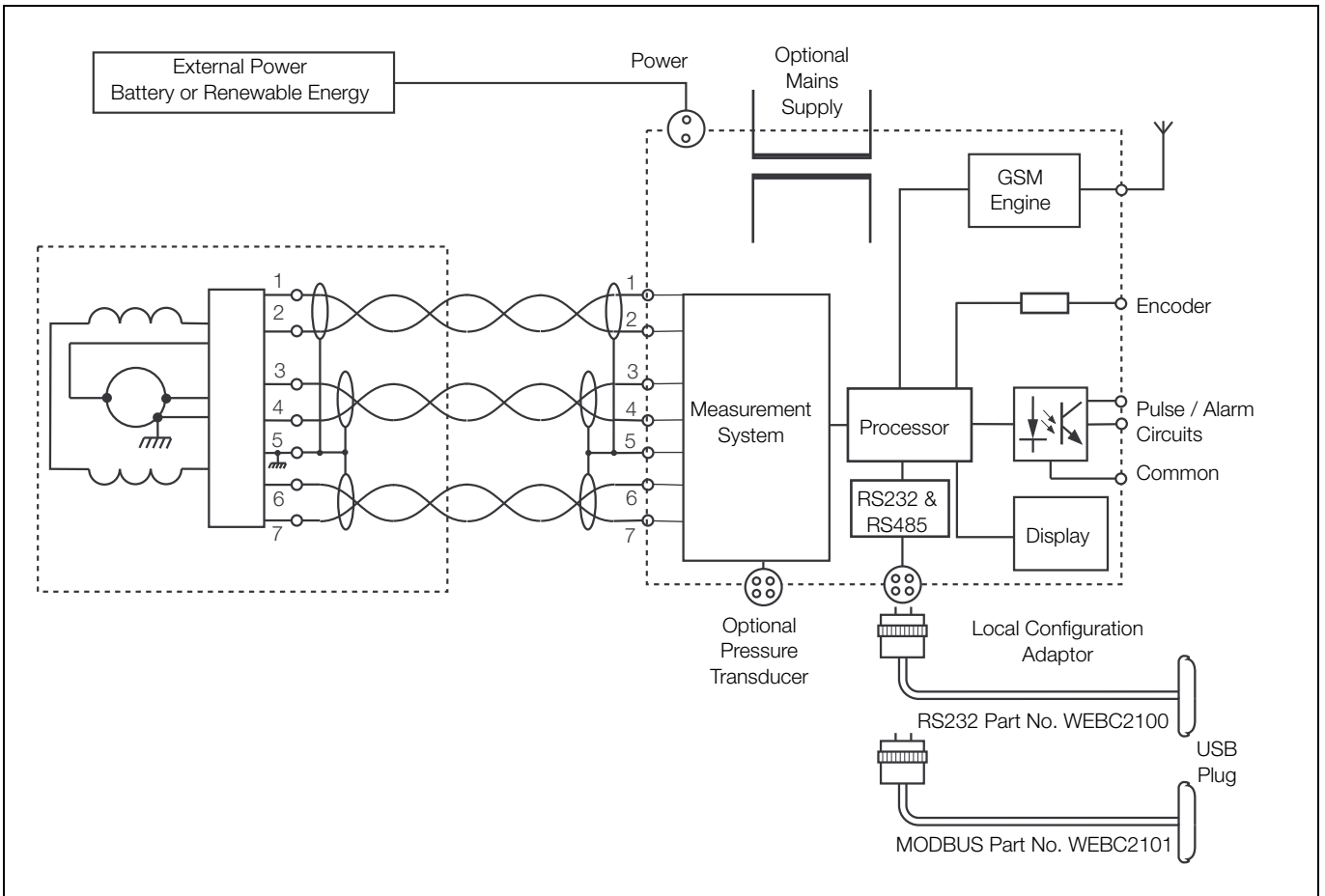

Transmitter

## Ordering Information – AquaMaster

				Main code				Optional code													
AquaMaster 3 reduced bore sensor				MM/GA	X	XXXX	X	X	X	X	X	X	0	X	X	0	0	0	0	0	
Country	Default flange type 40 to 600 mm	Default flange type 3 to 25 mm	Default cable entry																		
Australia	AS4087 PN16	Threaded ISO 228	20 mm	A																	
Germany	ISO7005 PN16	Threaded ISO 228	20 mm	D																	
Spain	ISO7005 PN16	Threaded ISO 228	20 mm	E																	
France	ISO7005 PN16	Threaded ISO 228	20 mm	F																	
UK	ISO7005 PN16	Threaded ISO 228	20 mm	G																	
Holland	ISO7005 PN16	Threaded ISO 228	20 mm	H																	
Italy	ISO7005 PN16	Threaded ISO 228	20 mm	I																	
USA	ANSI B 16.5 Class 150	Threaded NPSM	1/2 in. NPT	U																	
<b>Calibrated bore</b>																					
mm	in.																				
15	5/8					0015															
20	3/4					0020															
25	1					0025															
40	1 1/2					0040															
50	2					0050															
65	2 1/2					0065															
80	3					0080															
100	4					0100															
125	5					0125															
150	6					0150															
200	8					0200															
250	10					0250															
300	12					0300															
350	14					0350															
400	16					0400															
450	18					0450															
500	20					0500															
600	24					0600															
<b>Transmitter version and mounting</b>																					
Close-coupled sensor only, to suit AquaMaster 3 transmitter (DN40 to 600)																					
Remote Sensor only, to suit AquaMaster 3 transmitter																					
<b>Power supply</b>																					
AC (with backup)																					
Battery / renewable energy																					
<b>Options</b>																					
With earthing rings																					
<b>Cable length</b>																					
Not Required	0					60 m															
10 m	1					70 m															
20 m	2					80 m															
30 m	3					100 m															
40 m	4					150 m															
50 m	5					175 m															
						200 m															

Continued on next page...

**AquaMaster 3**  
Electromagnetic flowmeter

		Main code							Optional code									
AquaMaster 3 reduced bore sensor		MM/GA	X	XXXX	X	X	X	X	X	X	0	X	X	0	0	0	0	0
<b>Labelling / Construction</b>																		
ABB UK		0																
<b>Flange style / end connections</b>																		
As defined by country digit (see page 16)		0																
AS4087 PN14 (40-600mm [1.5 to 24in])		A																
AS4087 PN16 (50 to 600 mm [2 to 24 in.])		Z																
AS4087 PN21 (50 to 600 mm [2 to 24 in.])		B																
AS2129 Table C (40 to 600 mm [1.5 to 24 in.])		C																
AS2129 Table D (40-600mm [1.5 to 24in])		D																
AS2129 Table E (40 to 80 mm [1.5 to 3 in.])		H																
AS2129 Table F (40 to 80 mm [1.5 to 3 in.])		R																
ISO7005 / EN1092-1 PN10 (40 to 600 mm [1.5 to 24 in.])		M																
ISO7005 / EN1092-1 PN16 (40 to 600 mm [1.5 to 24 in.])		E																
ANSI B 16.5 Class 150 (1.5 to 12 in. only)		U																
JIS B2210, 5k (350 to 600 mm [14 to 24in])		L																
JIS B2210, 10k (40 to 600 mm [1.5 to 24 in.])		J																
Parallel thread to ISO228-1 Class B (15 to 25 mm [ <sup>5</sup> / <sub>8</sub> to 1 in.])		T																
Threaded to NPSM ( <sup>5</sup> / <sub>8</sub> to 1 in.)		Y																
<b>Cable entries</b>																		
MIL connector (sensor). Cable fitted / potted to remote sensor		5																
<b>Not used</b>		0																
<b>Calibration</b>																		
Class 2 Calibration, OIML* R49, 3 Point		2																
Class 1 Calibration, OIML* R49, 3 Point		B																
Class 2 Calibration, OIML* R49, with CalMaster 2 fingerprint		P																
Class 1 Calibration, OIML* R49, with CalMaster 2 fingerprint		C																
Class 2 Extended Range Calibration, MID*, with CalMaster 2 fingerprint		E																
Class 1 Extended Range Calibration, MID*, with CalMaster 2 fingerprint		D																
<b>Construction</b>																		
Standard		0																
<b>Not Used</b>		0																

\* OIML and MID options are available only in DN40, DN50, DN80, DN100, DN150, DN200, DN250 and DN300

				Main code				Optional code														
AquaMaster 3 full bore sensor				MM/GF	X	XXXX	X	X	X	X	X	X	X	0	X	0	0	0	0	0	0	
<b>Country</b>	<b>Default range</b>	<b>Default cable entry</b>																				
Australia	AS4087 Class 16	20 mm		A																		
Germany	ISO7005 PN16	20 mm		D																		
Spain	ISO7005 PN16	20 mm		E																		
France	ISO7005 PN16	20 mm		F																		
UK	ISO7005 PN16	20 mm		G																		
Holland	ISO7005 PN16	20 mm		H																		
Italy	ISO7005 PN16	20 mm		I																		
USA	ANSI B 16.5 Class 150	1/2 in. NPT		U																		
<b>Calibrated bore</b>																						
mm	in.																					
25	1					0025																
40	1 1/2					0040																
50	2					0050																
65	2 1/2					0065																
80	3					0080																
100	4					0100																
125	5					0125																
150	6					0150																
200	8					0200																
250	10					0250																
300	12					0300																
<b>Transmitter version and mounting</b>																						
Close-coupled sensor only, to suit AquaMaster 3 transmitter																						
Remote Sensor only, to suit AquaMaster 3 transmitter																						
<b>Power supply</b>																						
AC (with backup)																						
Battery / renewable energy																						
<b>Options</b>																						
With earthing rings																						2
<b>Cable length</b>																						
Not Required	0					60 m																6
10 m	1					70 m																7
20 m	2					80 m																8
30 m	3					100 m																A
40 m	4					150 m																C
50 m	5					175 m																D
						200 m																E
<b>Labelling / Construction</b>																						
ABB UK																						0

Continued on next page...

**AquaMaster 3**  
Electromagnetic flowmeter

	Main code										Optional code										
AquaMaster 3 full bore sensor	MM/GF	X	XXXX	X	X	X	X	X	X	X	X	0	X	0	0	0	0	0	0	0	
<b>Flange style / end connections</b>																					
As defined by country digit (see page 16)											0										
AS4087 PN16 Flanges (50 to 600 mm [2 to 24 in.] only)											Z										
ISO7005 PN10 Flanged (40 to 600 mm [1.5 to 24 in.] only)											M										
ISO7005 PN16 Flanged (40 to 600 mm [1.5 to 24 in.] only)											E										
ISO7005 / EN1092-1 PN25 (40 to 600 mm [1.5 to 24 in.] only)											N										
ANSI B 16.5 Class 150 (1.5 to 12 in. only)											U										
<b>Cable entries</b>																					
MIL connector (sensor). Cable fitted to remote sensor											5										
<b>Not used</b>																					
											0										
<b>Calibration</b>																					
3 Point																					2
3 Point with CalMaster 2 fingerprint																					P

	Main code			Additional codes																		
AquaMaster 3 transmitter	FET2211A0Y5G	X	X	X																		
<b>Power Supply</b>																						
Battery			5																			
AC + backup			7																			
External renewable energy			8																			
<b>Input and output signal type</b>																						
Mobile radio communication										H												
MODBUS with RS485										M												
ScanReader										S												
Without										Y												
<b>Note.</b> Pulse outputs and RS232 are always present																						
<b>Configuration</b>																						
Standard																					1	
<b>Accessories</b>																						
RS232 Communication lead	AC	<b>Logger and protocols</b>																				
Manganese alkaline battery pack	AD	ABB																			LP1	
Lithium high temperature pack	AE	Capula																			LP2	
Battery container with lead	AF	Technolog																			LP3	
		Primayer																				LP4
Quad band antenna – integral	G3	Hydreka																				LP5
Quad band antenna – remote, 1 m	G6	QTech																				LP6
Quad band antenna – remote, 5 m	G7	Areal Topkapi																				LP7
		EcoTech																				LP8
		AutoChart																				LP9
		HydroComp																				LPA
		No logger																				LP0
<b>Documentation language</b>																						
German	M1	French																				M4
Italian	M2	English (default)																				M5
Spanish	M3																					
<b>Pressure options</b>																						
Without																						PT0
Remote, no transducer, MID compatible																						PT2
Remote, with ABS transducer, 5 m cable, MID compatible																						PT4
Remote, with ABS transducer, 10 m cable, MID compatible																						PT5
Remote, with ABS transducer, 20 m cable, MID compatible																						PT6
10 Bar (145 psi)																						PS1
16 Bar (232 psi)																						PS2
20 Bar (300 psi)																						PS3
<b>Certification</b>																						
MID																						CM1

# Contact us

## **ABB Limited**

### **Process Automation**

Oldends Lane  
Stonehouse  
Gloucestershire GL10 3TA  
UK

Tel: +44 1453 826 661

Fax: +44 1453 829 671

## **ABB Inc.**

### **Process Automation**

125 E. County Line Road  
Warminster  
PA 18974  
USA

Tel: +1 215 674 6000

Fax: +1 215 674 7183

[www.abb.com](http://www.abb.com)

## Note

We reserve the right to make technical changes or modify the contents of this document without prior notice. With regard to purchase orders, the agreed particulars shall prevail. ABB does not accept any responsibility whatsoever for potential errors or possible lack of information in this document.

We reserve all rights in this document and in the subject matter and illustrations contained therein. Any reproduction, disclosure to third parties or utilization of its contents – in whole or in parts – is forbidden without prior written consent of ABB.

Copyright© 2011 ABB

All rights reserved

3KXF224203R1001

Windows, Microsoft is a registered trademark of Microsoft Corporation in the United States and/or other countries.

MODBUS is a registered trademark of the Modbus-IDA organization.