

Sample Conditioning for Kiln

SCK

Sampling System for Dry Gas Sampling

at Rotary Cement Kiln Gas Exit and Calciner Gas Exit

Data Sheet

10/23-8.81 EN April 2009

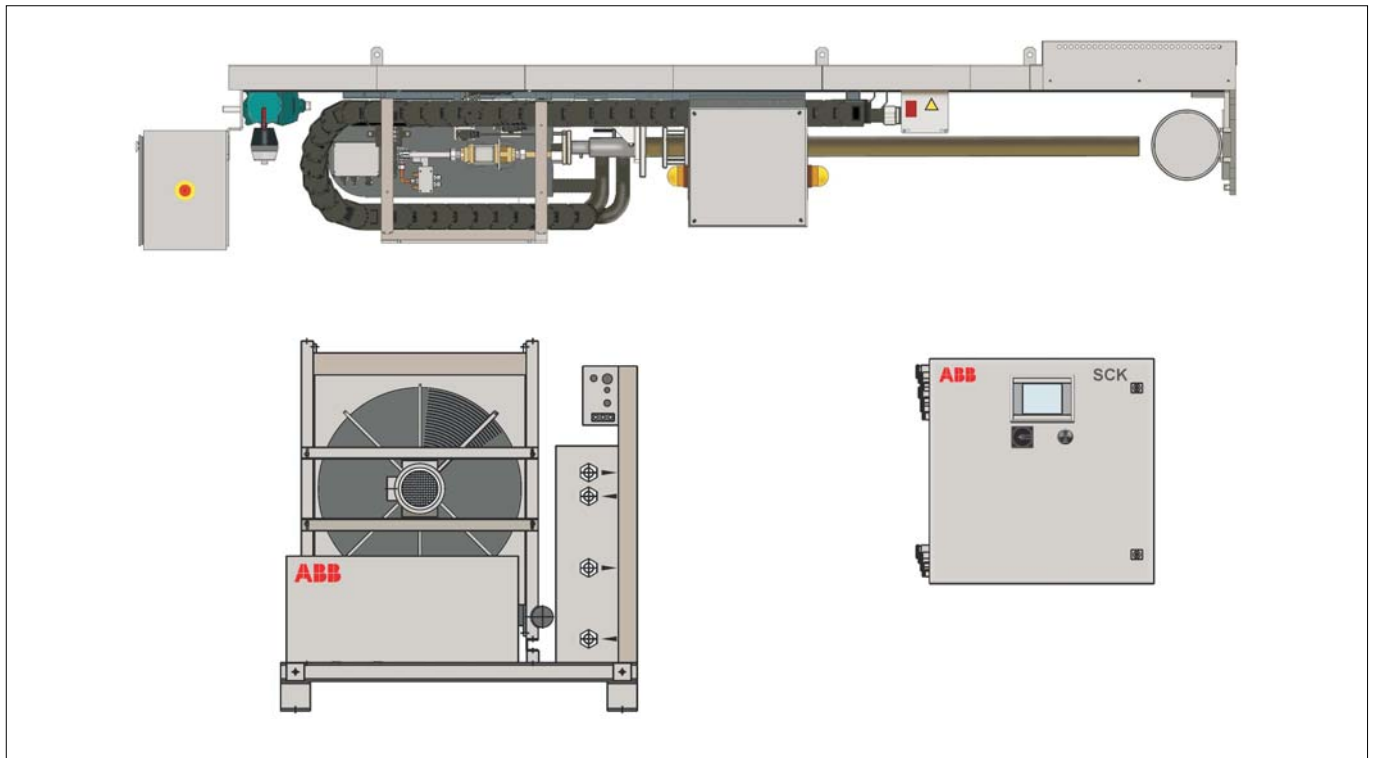

- Complete sampling system comprising only three pre-assembled modules
- Pre-assembled tubes and bus cables significantly reducing the system installation time
- Robust system design
- Standardized interfaces to ABB's and third-party manufacturers' analyzer systems
- Pneumatically driven probe retractor with dust cover and automatic oven flap
- Robust, water cooled gas sampling probe types
- Probe type H with automatic mechanical cleaning
- Automatic probe retraction in case of compressed air or power supply failure
- Automatic cyclic cleaning of probe and filter
- Closed cooling water circuit with speed-controlled heat exchanger
- Continuous monitoring of cooling water pressure, temperature and flow
- Control unit with color touch panel featuring comprehensive operation, diagnosis and maintenance capabilities
- Graphic trend displays for predictive maintenance purposes
- Password-protected menu levels adapted for the needs of different user groups in the cement plant
- Various tools for remote operation and remote diagnosis available
- User interface in national languages available on request

Application and System Overview

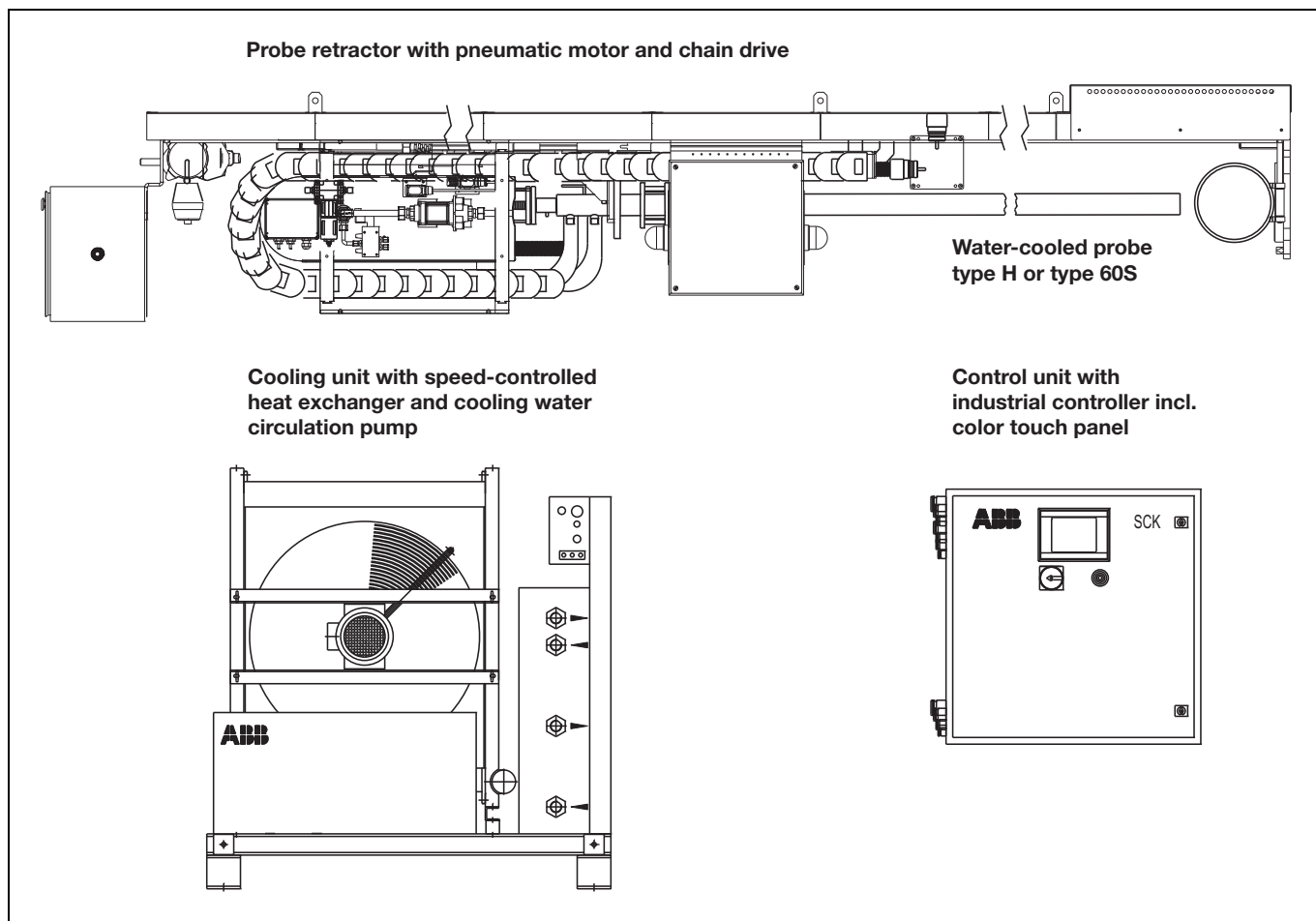

Application

The SCK sampling system is designed for sampling of hot cement flue gas with a high dust load for gas analysis. Usage sites are the rotary cement kiln gas exit and the calciner gas exit in dry process clinker kilns. The system is suitable for applications in rough environmental conditions.

The SCK sampling system is preferably combined with ABB's ACX analyzer system. The combination of SCK with analyzer systems of third-party manufacturers is also possible.

System Overview

The SCK sampling system comprises the following modules:

- Probe retractor with pneumatic motor and chain-driven water-cooled probe type H or type 60S
- Cooling unit with speed-controlled heat exchanger and cooling water circulation pump
- Control unit with industrial controller incl. color touch panel

Retractor

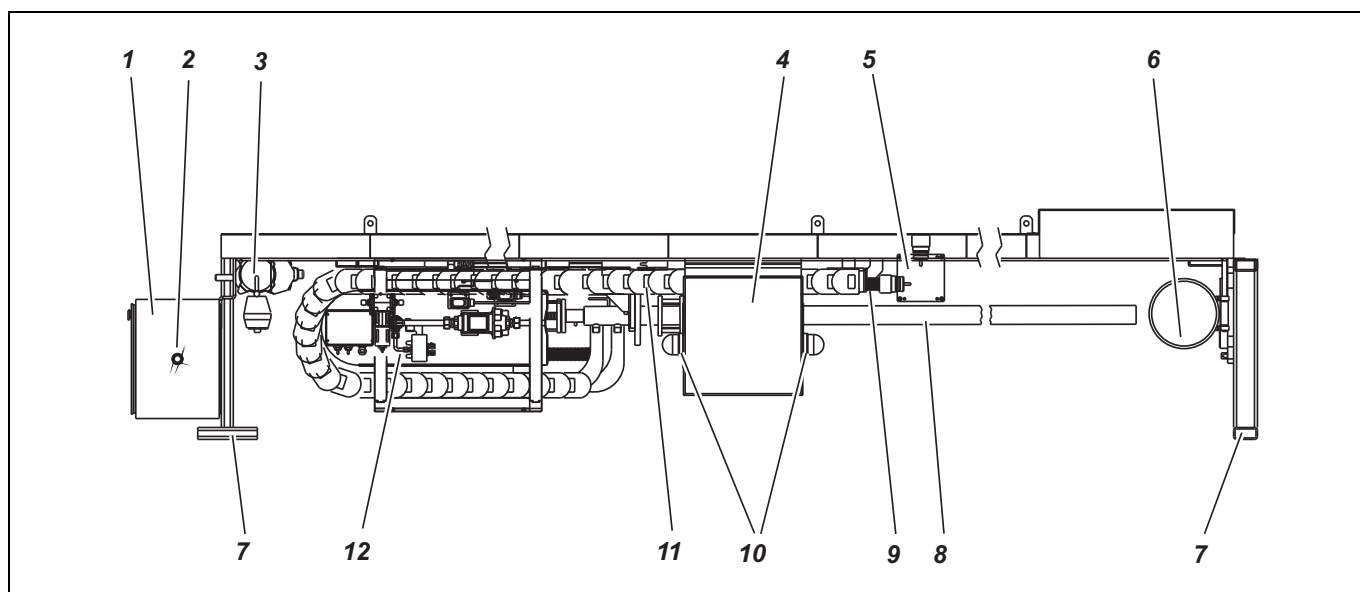

- | | |
|---|---|
| <p>1 Pneumatic box 2 Emergency stop button "Probe action" 3 Pneumatic motor 4 Terminal box for system-internal electric cables connections 5 Heated connection box for sample gas line connection 6 Pneumatically driven oven flap</p> | <p>7 Transport brackets (dismounted at installation site) 8 Gas sampling probe type H (see p. 5) or type 60S (see p. 6) 9 Internal heated sample gas line 10 Flashing lights "Probe action" 11 Cable drag chain 12 Probe cleaning unit</p> |
|---|---|

Description

The retractor with its pneumatic chain driver carries the gas sampling probe in a double beam construction. It is used to insert and retract the probe to defined front or rear positions in order to scrape off possible material deposits or encrustations.

The integrated pneumatically driven oven flap closes the sampling opening when the probe is retracted, thus preventing hot and toxic gases to exhaust from the oven and cause damage to man and machinery.

The integrated cable drag chain bundles the tubes and cables for smooth probe movements.

The probe is automatically retracted when

- Cooling water temperature is too high
- Cooling water flow or pressure is too low
- Cooling water circulation pump failure occurs
- Compressed-air failure occurs
- Power supply failure occurs

Technical Data

Double Beam Construction

- Chain drive
- Pneumatic motor
- Probe carrier with installed gas sampling probe
- Pneumatically driven oven flap
- Dust cover

Cable Drag Chain

- Cooling water tubes
- Electric cables
- Pneumatic tubes
- Self-regulating heated sample gas line

Pneumatic Box

Pneumatic equipment for compressed-air conditioning and control of:

- Probe movement
 - Oven flap opening/closing
 - Plunger movement (for probe type H)
- Connection of external compressed air

Terminal Box

Connection of system-internal power supply and signal cables

Heated Connection Box

Connection of an external unheated or heated sample gas line (see System Technical Data, page 10)

Dimensions

Dimensional drawing see page 12

Standard retractor lengths:

4500 mm for probe length $L = 1.5\text{--}2.5$ m

5500 mm for probe length $L = 3.0\text{--}3.5$ m

Option: Retractor length adjusted to the probe length; retractor length is approx. probe length $L + 2$ m.

Weight

Max. 600 kg incl. probe

Mounting

- Hanging mounting
 - 6 fixing points, required bearing capacity 10000 N each
- Mounting diagram see page 14

Gas Sampling Probe Type H

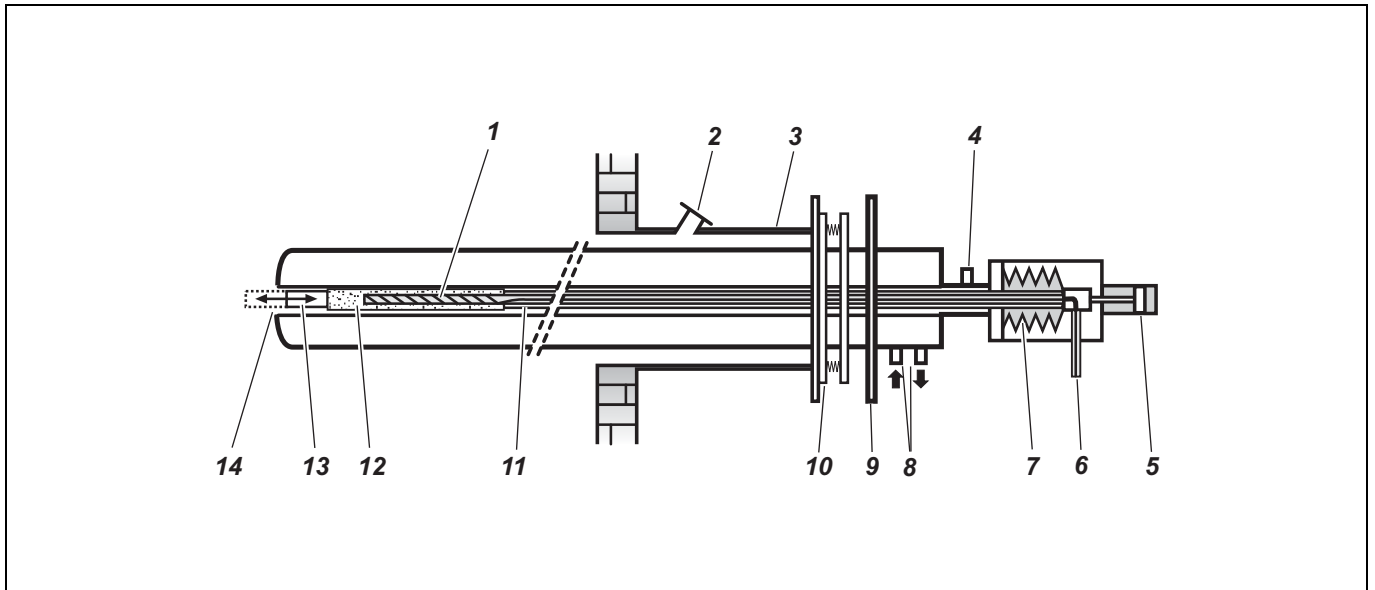

- | | | | |
|----------|---------------------------------|-----------|---|
| 1 | Heated gas pipe | 8 | Cooling water connections |
| 2 | Connection for air shock blower | 9 | Mounting flange (for mounting to the retractor) |
| 3 | Mounting pipe | 10 | Tube sealing device |
| 4 | Compressed-air connection | 11 | Pipe |
| 5 | Compressed-air cylinder | 12 | Filter |
| 6 | Sample gas outlet | 13 | Plunger |
| 7 | PTFE bellows | 14 | Sample gas suction opening |

Description

The water-cooled gas sampling probe type H is installed in kilns, where extremely hard encrustations are to be expected.

By using the probe type H, long measuring periods without interruptions are possible: The pneumatically driven plunger which is welded on the filter tip mechanically breaks the encrustations at the probe gas entry without interruption of the measurement.

After a preset number of plunger movements, the probe is automatically retracted. Thereby, possible material deposits are scraped off. After re-insertion filter and tube tip are purged with compressed air. Through the automatic probe movement and purging it is assured that the probe tube is practically free of deposits and the filter is free of dust.

Technical Data

Material

Cooling tube: EN4541 (ASTM 321)
Inner gas pipe: EN4436 (ASTM 316)

Probe Length

L = 1.5 m / 2.0 m / 2.5 m preferably for use at calciner gas exit
L = 3.0 m / 3.5 m preferably for use at cement kiln gas exit

Weight

approx. 95 kg for probe length L = 3.0 m

Gas Sampling Probe Type 60S

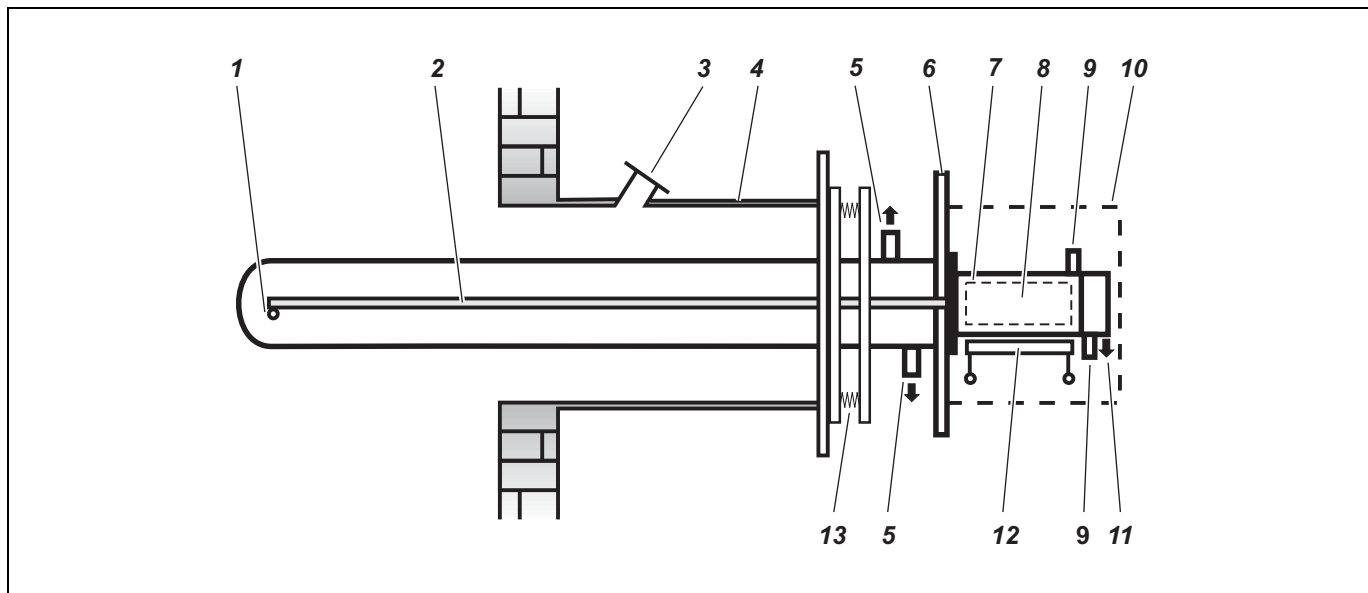

- | | | | |
|----------|---------------------------------|-----------|----------------------------|
| 1 | Sample gas suction openings | 8 | Ceramic filter |
| 2 | Gas pipe | 9 | Compressed-air connections |
| 3 | Connection for air shock blower | 10 | Protective casing |
| 4 | Mounting pipe | 11 | Sample gas outlet |
| 5 | Cooling-water connections | 12 | Ring heater |
| 6 | Mounting flange | 13 | Tube-sealing device |
| 7 | Filter unit FE2 | | |

Description

The water-cooled gas sampling probe type 60S is installed in kilns where less hard encrustations are to be expected.

By using the probe type 60S with two sample gas openings at the side of the probe tip, an effective pre-dedusting of the sample gas is achieved at the tip thus reducing the frequency of the automatic back purging actions.

After a preset number of back purging actions of the filtering unit and the sample pipe, the probe is automatically retracted. Thereby, possible material deposits are scraped off. After re-insertion filter and tube tip are purged with compressed air. Through the automatic probe movement and purging it is assured that the probe tube is practically free of deposits and the filter unit is free of dust.

Technical Data

Material

Cooling tube: EN4541 (ASTM 321)
Inner gas pipe: EN4571 (ASTM 316Ti)

Probe Length

L = 1.5 m / 2.0 m / 2.5 m preferably for use at calciner gas exit
L = 3.0 m / 3.5 m preferably for use at cement kiln gas exit

Weight

approx. 45 kg for probe length L = 3.0 m

Cooling Unit

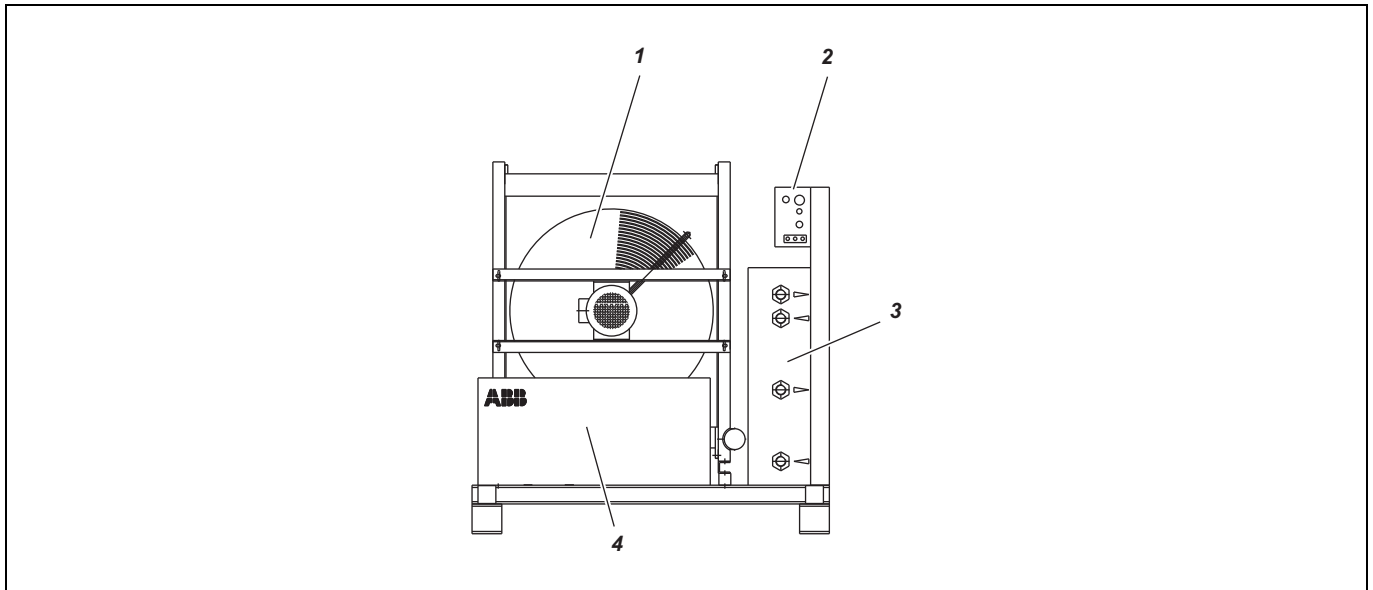

- 1 Heat exchanger
- 2 Electrical connections
- 3 Cooling water connections
- 4 Cooling water supply pump and analog sensors

Description

Due to the prevailing conditions a cooling of the gas sampling probe is mandatory. The cooling unit is used to provide and monitor the cooling water supply. The cooling water circuit is completely closed thus minimizing cooling water consumption and avoiding scaling.

The cooling unit contains the speed-controlled heat exchanger and the cooling water supply pump as well as analog sensors for monitoring the cooling water temperature, flow and pressure.

Technical Data

Cooling Water Circuit

- Capacity (first fill) 50 to 60 l
- Pressure 1 to 2 bar
- Controlled temperature 75 to 85 °C
- Circulation 5 to 6 m³/h
- Drinking water quality, anti-freeze agent necessary at ambient temperature < 0 °C

Cooler Block Material

Copper/brass for corrosion-proof operation

Dimensions

Dimensional drawing see page 13

Weight

approx. 250 kg

Mounting

Ground mounting

Mounting diagram see page 15

Control Unit

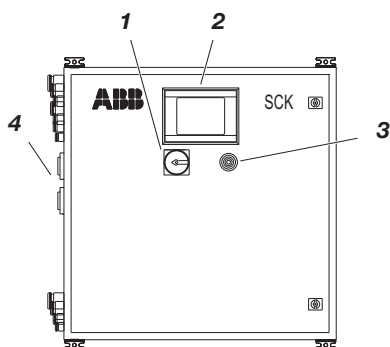

- 1 Maintenance switch (lockable)
- 2 Color touch panel
- 3 Buzzer
- 4 Main switches

Description

The control unit comprises the control system including the display and operator control unit for monitoring and operating the gas sampling system. Electrical power supply and all signals for the entire gas sampling system are fed-in and distributed in the control unit.

The control program offers different levels which are partly password-protected. Various locking mechanisms prevent possible sampling probe damages caused by erroneous operation or failure of single modules.

Operation

Probe movement and cleaning are controlled either in automatic mode or in manual mode. The program sequences are menu-driven and provide:

- Operation (automatic or manual probe retraction/insertion, oven flap opening/closing, probe cleaning, etc.)
- Diagnosis (cooling water parameters, trend displays, status messages, etc.)
- Set-up for process optimization (timers, limit parameters, etc.)
- Login levels to allow authorized access only (operators, technicians, etc.)
- Support via help texts

Technical Data

Modules

- Industrial controller with display and operator control unit
- Color touch panel with special-hardened glass surface
- Maintenance switch (lockable)
- Buzzer
- Main switches
- Input and output terminals
- Automatic fuses
- Power supply
- Frequency controller

Material

Sheet steel

Color

Light gray (RAL 7035)

Degree of Protection

IP54 to EN 60529

Dimensions

Dimensional drawing see page 13

Weight

approx. 75 kg

Mounting

Wall mounting
Mounting diagram see page 16

Pneumatic and Piping Diagram

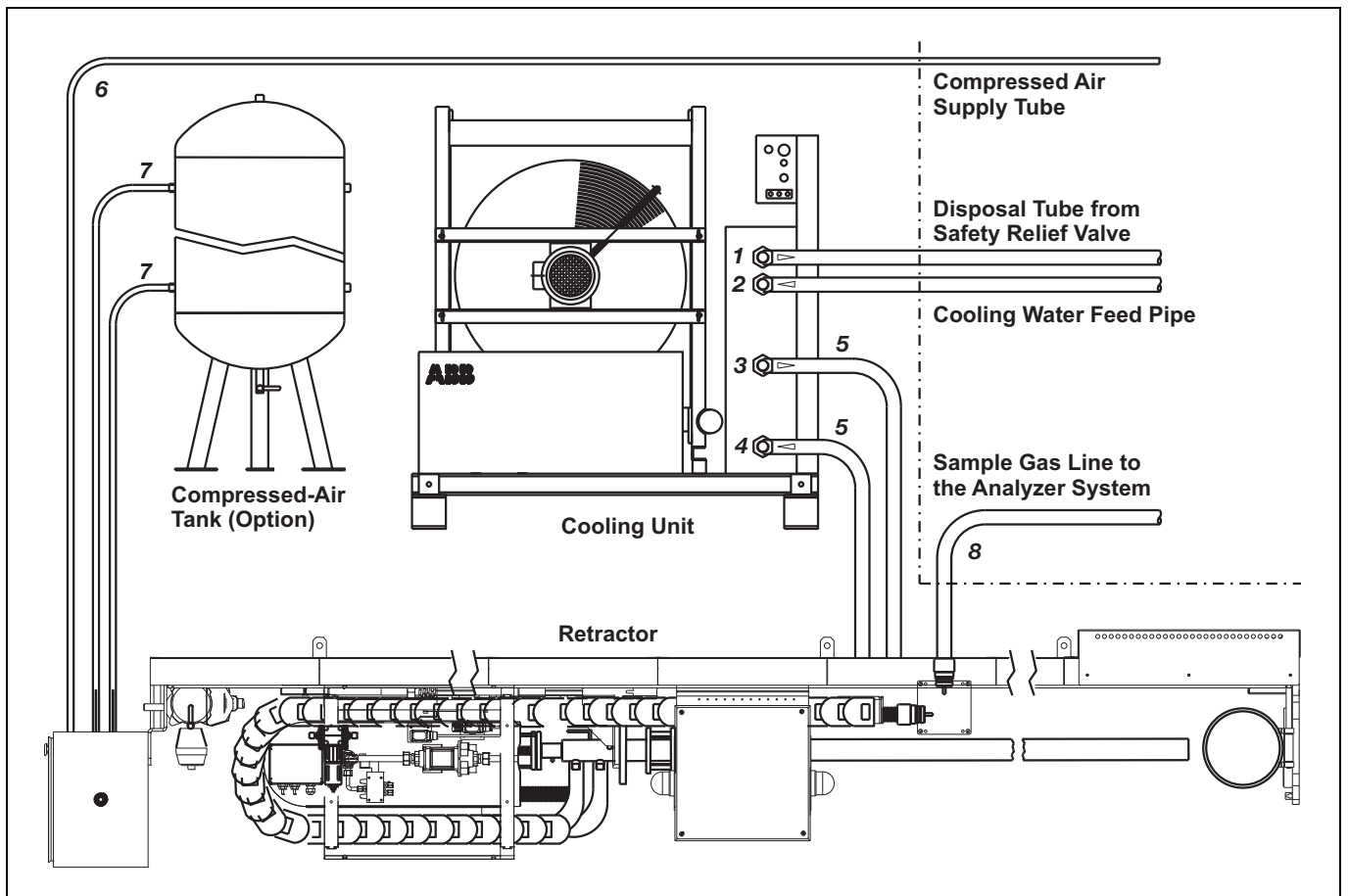

- | | |
|-------------------------------------|--|
| 1 Safety relief valve outlet | 6 Compressed-air supply tube (compressed-air supply requirements see page 11) |
| 2 Cooling water inlet | 7 Compressed-air tubes |
| 3 Cooling water feed | 8 Unheated or heated sample gas line to the analyzer system (requirements see page 10) |
| 4 Cooling water return | |
| 5 Cooling water tubes | |

System Technical Data

Connections

Power Supply

Control Unit

| | |
|------------------------------------|-----------------------------|
| 230/400 VAC supply lines: | 4.0 mm ² (AWG10) |
| UPS 230 VAC supply lines (Option): | 2.5 mm ² (AWG12) |

Control Unit to Retractor

| | |
|--|-----------------------------|
| 230 VAC supply lines: | 1.5 mm ² (AWG14) |
| 230 VAC supply lines (for probe type 60S): | 1.5 mm ² (AWG14) |
| 24–30 VAC supply lines (for probe type H): | 2.5 mm ² (AWG12) |
| 24 VDC supply lines: | 1.0 mm ² (AWG18) |

Control Unit to Cooling Unit

| | |
|-----------------------|-----------------------------|
| 400 VAC supply lines: | 1.5 mm ² (AWG14) |
| 24 VDC supply lines: | 1.0 mm ² (AWG18) |

Signal Interfaces

- Relay contacts (max. load 110 VDC/230 VAC, 1.5 A)
- Profibus DP slave RS485 (optional)
- Modbus (optional, for connection to ACX analyzer system)

Power supply and signal interfaces diagram see page 17

System Bus CANopen

2 cables attached to the control unit and to the retractor for connection to the cooling module, length = 15 m each

Compressed-Air Connections (at Retractor)

Fittings, diameter 18 mm (supplied)

Cooling Water Connections (at Cooling Unit)

1" (supplied)

Sample Gas Line to the Analyzer System

The sampling system can be prepared for connection of an unheated gas sample line or a self-regulating heated sample gas line, depending on application.

Requirements on a heated sample gas line: No flange connection, outside diameter of isolation 45–48 mm, outside diameter of inner core 6 mm, length of nipple max. 30 mm, temperature-resistant up to 150 °C.

Accessories

Cooling Water Tube

25/39x7 mm, length = 30 m (can be cut as required), incl. fittings, weight approx. 40 kg (included in delivery)

Compressed-Air Tube

PA 18/14x2 mm, length = 25 m, (can be cut as required), incl. fittings (included in delivery of optional compressed-air tank)

Acoustic Emission

Retractor and Cooling Module

approx. 89 dB(A)

Declaration of Conformity

Electrical Safety

The regulations of European directive 2006/95/EC for low voltage are complied with.

Electromagnetic Compatibility

The regulations of European directive 2004/108/EC for EMC are complied with.

Machinery

The regulations of European directive 2006/42/EC for machinery are complied with.

Requirements at the Installation Site

Power Supply

Operating Voltage

230/400 VAC, $\pm 10\%$, 50 Hz (fuses 3 x 20 A required),
3-phase connection (5 wires, N-conductor necessary)
or
230/400 VAC, $\pm 10\%$, 60 Hz (fuses 3 x 20 A required),
3-phase connection (5 wires, N-conductor necessary)
or
3 x 208 VAC, $\pm 10\%$, 60 Hz incl. transformer (fuses 3 x 20 A
required), 3-phase connection (4 wires)
Other voltages on request

Power Consumption

max. 6 kVA

Option "UPS"

230 VAC or 120 VAC, $\pm 10\%$, 50 to 60 Hz (fuse 1 x 6 A required)

Compressed Air Supply

Purpose

For movement and cleaning of the gas sampling probe

Requirements

Compressed air free of dirt, oil and water droplets, 6 bar
positive pressure, dried to 5 °C below ambient temperature
Recommendation: Instrument air (dew point -40 °C)

Consumption

approx. 3 m³/h (at standard conditions)

Emergency Tank

A compressed-air tank with a capacity of at least 250 l must
be installed near the sampling system. This emergency tank is
necessary to supply sufficient compressed air for retracting
the probe from the kiln in case of a compressed-air or power
supply failure. The tank can be provided by the customer or
by ABB Analytical.

Cooling Water Supply

Purpose

For cooling of the gas sampling probe

Requirements

Drinking-water quality
Anti-freeze agent (approx. 20 l, without anticorrosion agent,
oil-free) must be added if the ambient temperature is < 0 °C.

Capacity

First fill 50 to 60 l at 1 to 2 bar

Ambient Conditions

Ambient Temperature

+5 to +45 °C,
-20 to +45 °C with anti-freeze agent in the cooling water
Compressed Air Tank (option): -10 to +50 °C

Transport and Storage Temperature

+5 to +55 °C,
-20 to +55 °C after draining and drying all parts in contact
with cooling water or condensate

Relative Air Humidity

$\leq 75\%$ annual average, for a short time up to 95 %,
infrequent and slight condensation possible

Installation Site

The control unit must be installed at a low-vibration location
and protected from direct sunshine, dust and rain.

Process Gas Conditions

Pressure

± 3 kPa related to atmospheric pressure

Temperature

max. 1300 °C

Dust Load

max. 2000 g/m³

Gas Velocity at Sampling Point

max. 20 m/sec

Retractor: Dimensional Drawing

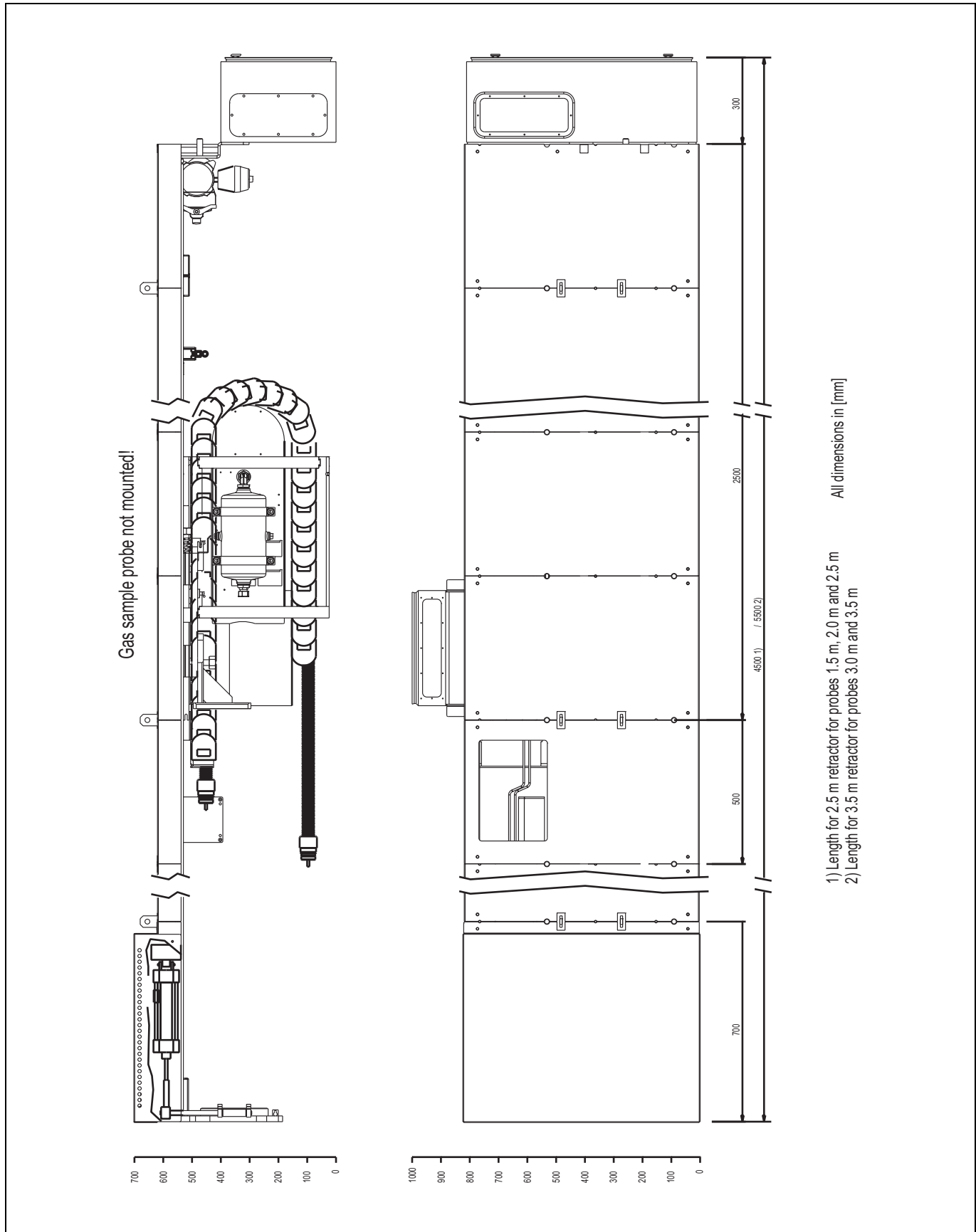

Cooling Unit: Dimensional Drawing

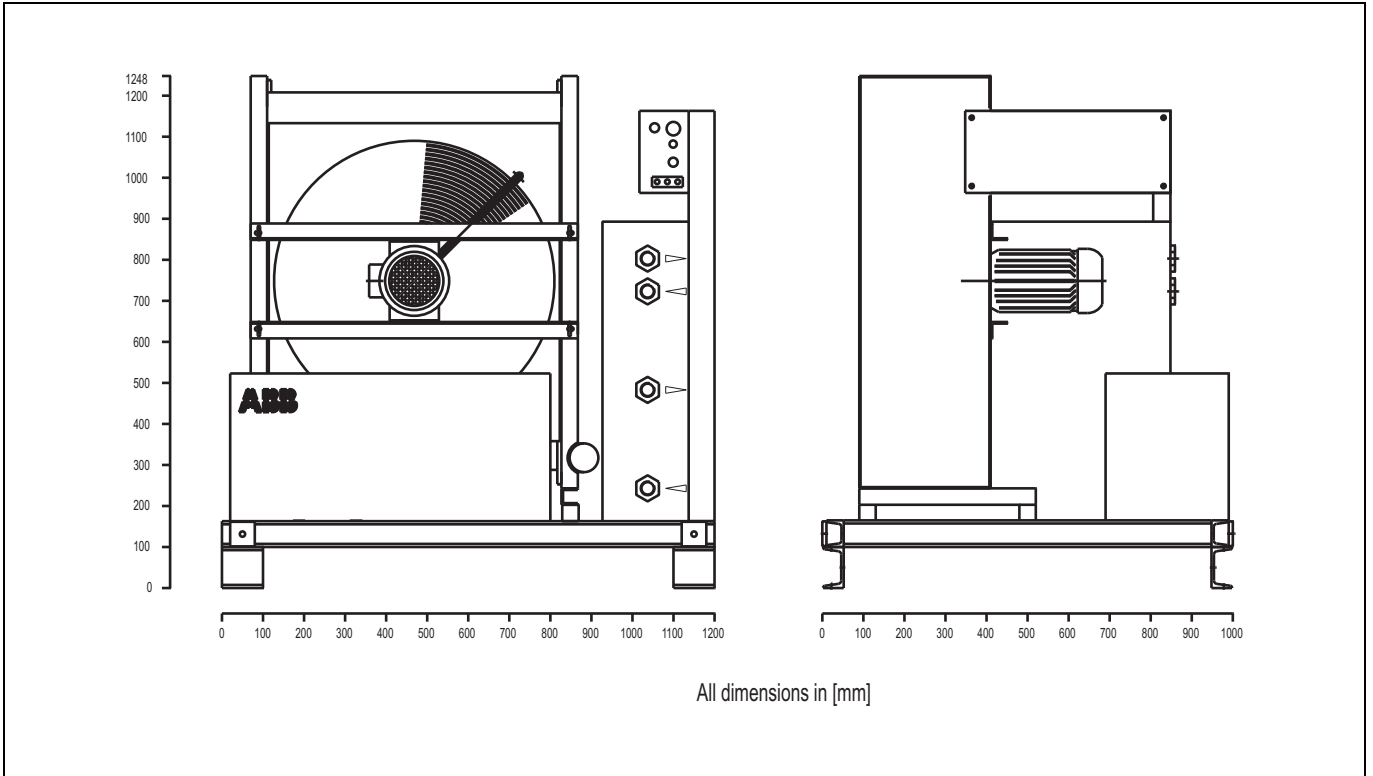

Control Unit: Dimensional Drawing

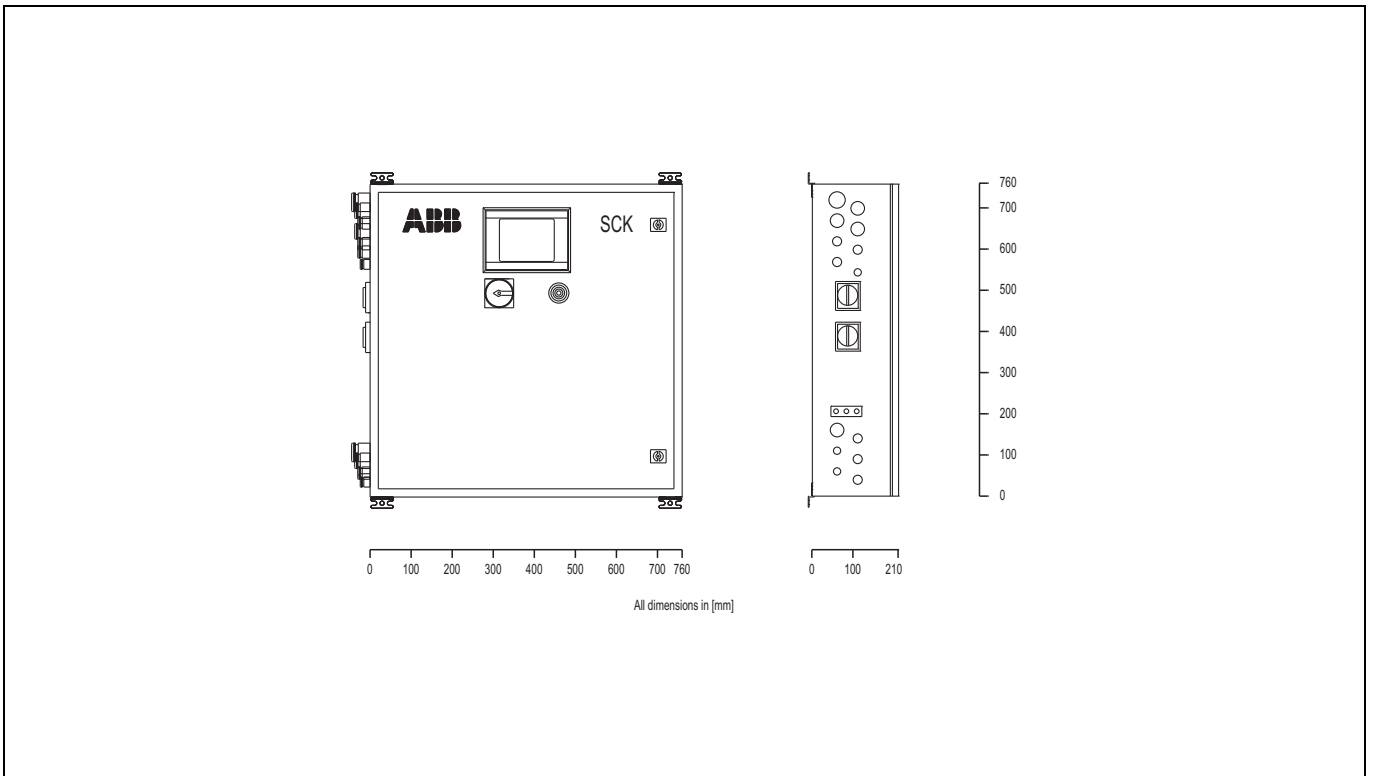

Retractor: Mounting Diagram

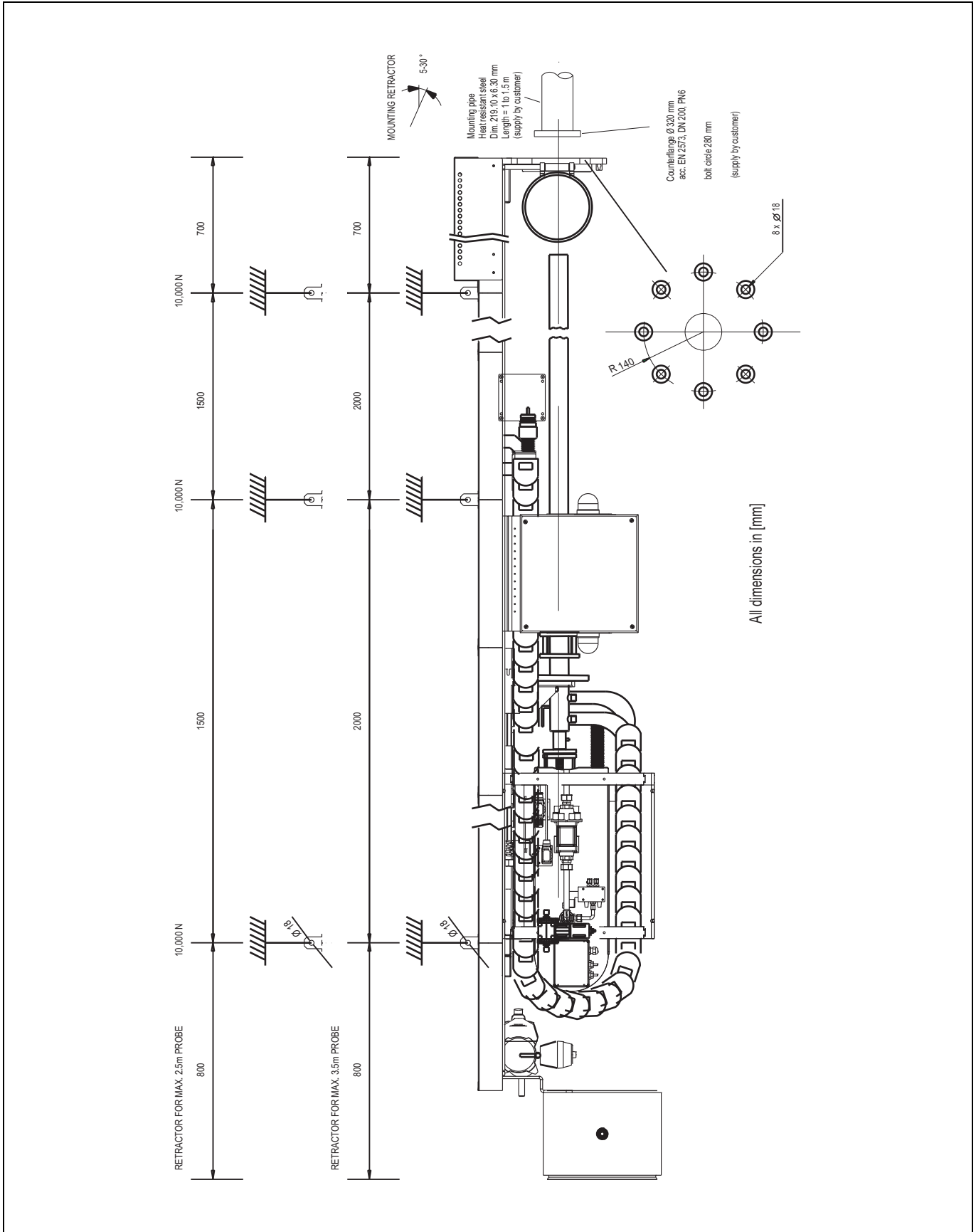

Cooling Unit: Mounting Diagram

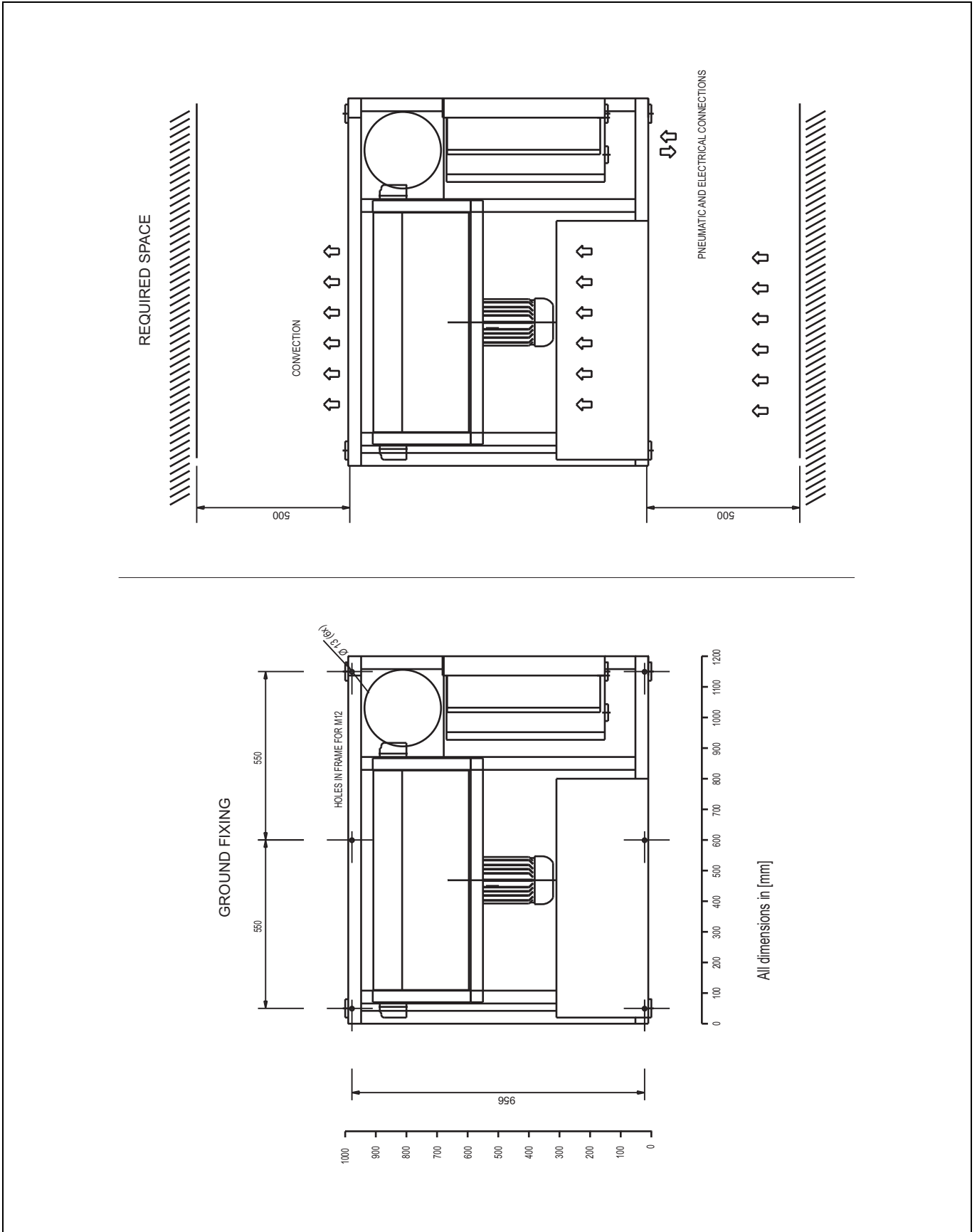

Control Unit: Mounting Diagram

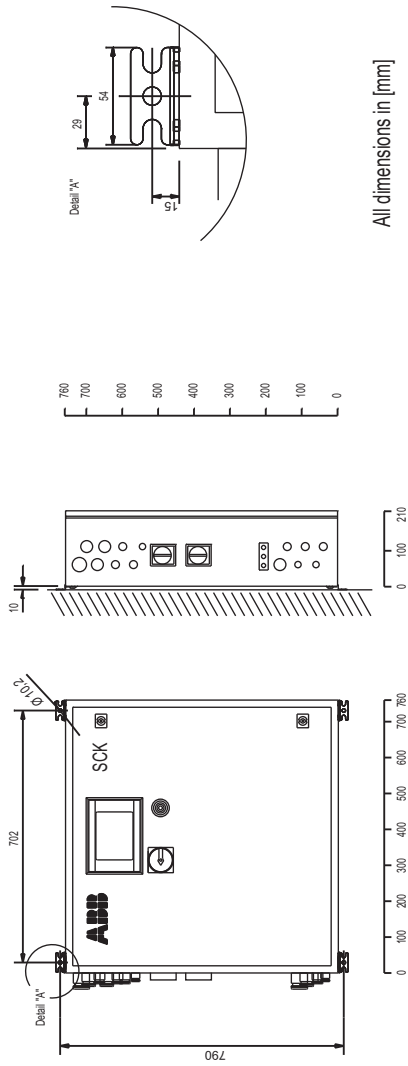

All dimensions in [mm]

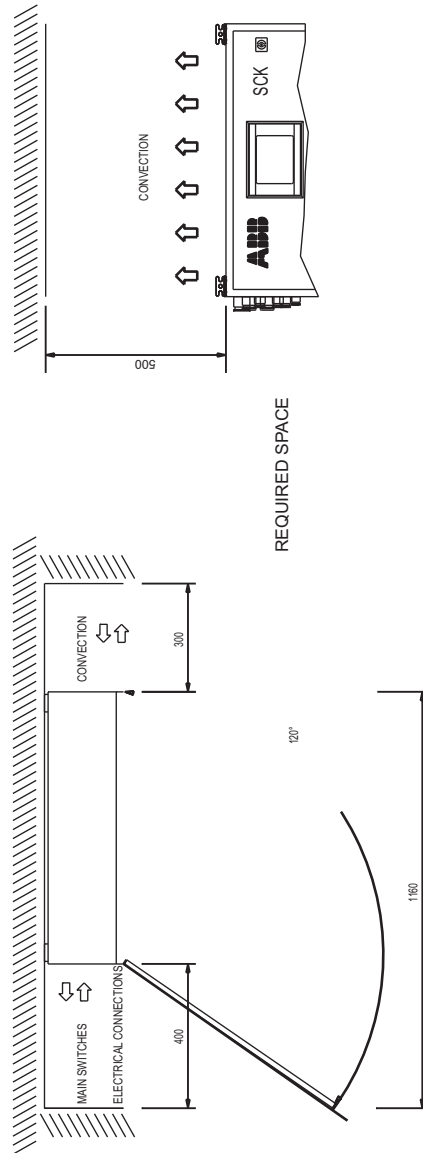

Control Unit: Power Supply and Signal Interfaces Diagram



ABB has Sales & Customer Support expertise
in over 100 countries worldwide.

www.abb.com

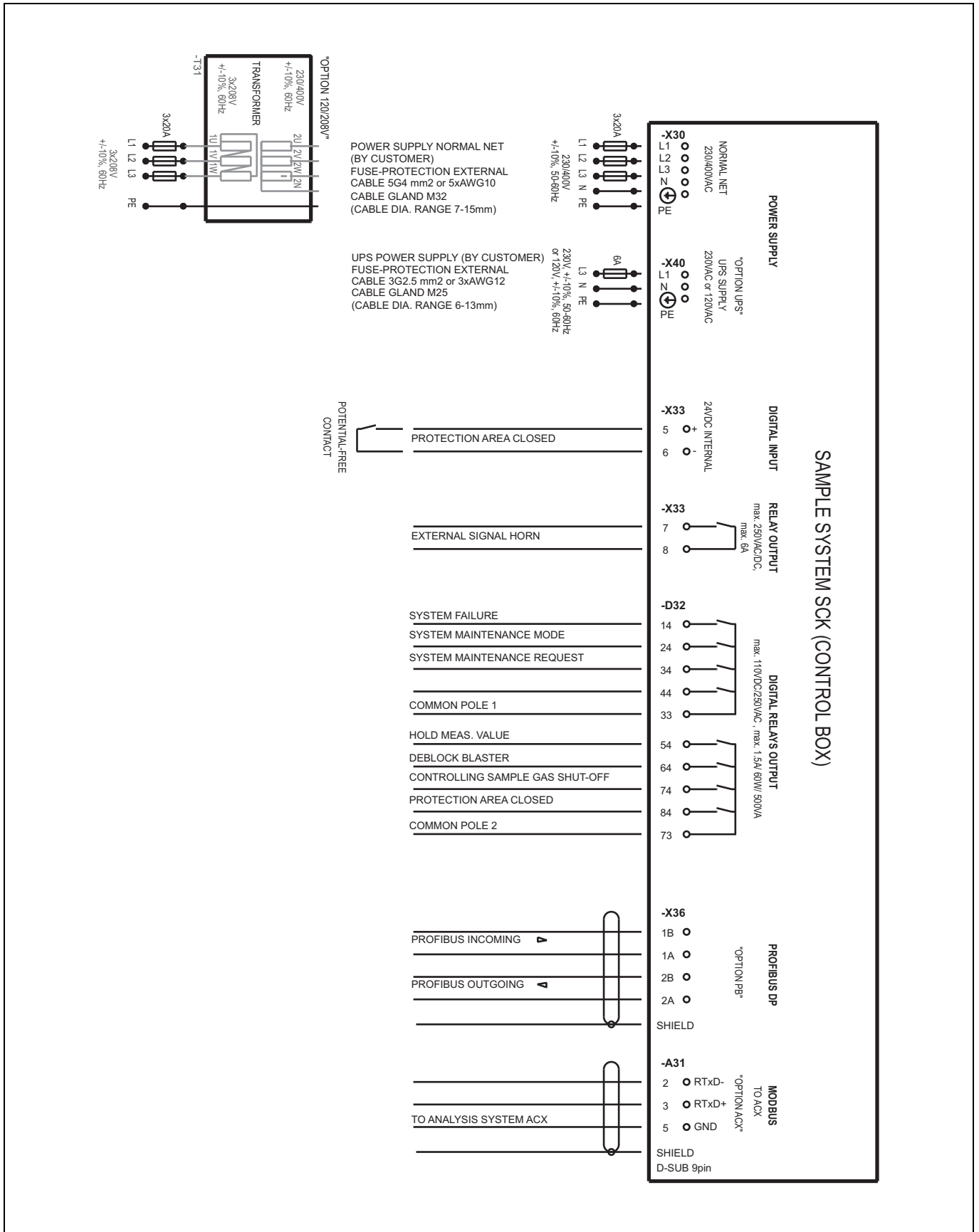

ABB Automation GmbH

Analytical
Stierstaedter Strasse 5
60488 Frankfurt am Main
Germany
Phone: +49 69 7930-40
Fax: +49 69 7930-4566
E-Mail: analytical-mkt.deapr@de.abb.com

The Company's policy is one of continuous product
improvement and the right is reserved to modify
the information contained herein without notice.

Printed in the Fed. Rep. of Germany (04.09)

© ABB 2009