

Model NBC

Absolute pressure transmitter

Deltapi N Series
A complete range of
pneumatic pressure transmitters

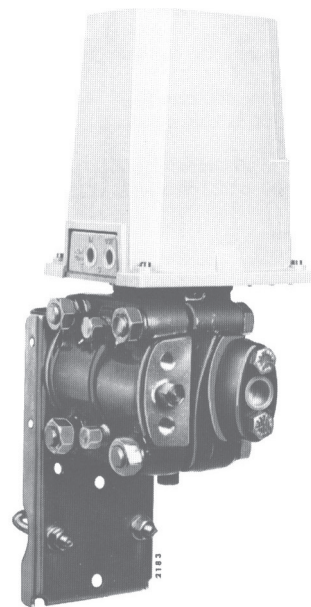

Introduction

The blind type absolute pressure transmitter mod. NBC is used to measure an absolute pressure and convert it into a proportional pneumatic signal.

DESCRIPTION

The instrument works on the force-balance principle and consists of two main units.

The measuring unit detects the absolute-pressure variation and consists of two forged bodies and a measuring capsule. A diaphragm capsule is placed within two halfbodies to relieve the absolute pressure applied to the positive chamber. The capsule is available in two versions: 2in or 3in diameter diaphragms inside of which is obtained the vacuum. The structure of the diaphragm capsule can withstand the maximum overrange without damage.

The transmission unit converts the force applied to the measuring element into a proportional output pneumatic signal.

The output pressure, generated by a flapper nozzle relay, is fed to a feedback bellows with a rising pressure until the bellows force balances that of the measuring element.

Span value continuously adjustable by an internal micrometric screw.

Zero value adjustable by an external screw.

Mounting in a vertical position on 2in diameter pipe by a special bracket.

OPTIONAL EXTRA FEATURES

Special feedback bellows allow to reduce the standard calibration span to a lower value (see table)

A zero suppression device allows to set as a zero of the transmitter a measured variable value different from the absolute zero.

The sum of the zero suppression value (S) plus the calibrated span cannot exceed the upper range limit (M) suitable for the diaphragm capsule : $S + \text{span} \leq M$ (see table).

Air filter regulator can be directly mounted on the transmitter, with or without pressure gauge, and connected with piping and fittings either in stainless steel or copper.

Special versions of air filter regulator and gauges, in stainless steel, are available on request.

Oxygen measurements, special degreasing and final test operations can be required on the oxygen measuring transmitter.

SPECIFICATIONS

The data were obtained from laboratory tests on standard instruments with:
carbon steel or AISI 316L bodies; AISI 316L measuring element with silicone oil filling; gasket: PTFE;
calibration span : 18 kPa - 180 mbar (for 3in diaphragm), 70 kPa - 700 mbar (for 2in diaphragm)

MEASURING CAPSULE (DIAPHRAGM DIA.)	SPAN LIMITS (absolute) min. and max.	RANGE LIMITS (absolute) lower and upper (M)	MAXIMUM ZERO SUPPRESSION (S)	OVERRRANGE LIMIT
2 in	30 and 170 kPa 300 and 1700 mbar	0 and 170 kPa 0 and 1700 mbar	140 kPa 1400 mbar	2.5 MPa 25 bar
3 in	5 and 52 kPa 50 and 520 mbar	0 and 52 kPa 0 and 520 mbar	47 kPa 470 mbar	
3 in with special feedback bellows	2.5 and 7.5 kPa 25 and 75 mbar	0 and 52 kPa 0 and 520 mbar	49.5 kPa 495 mbar	

Air supply

nom. 140 kPa (1.4 bar, 20 psi); min. 125 kPa (1.25 bar, 18 psi); max. 175 kPa (1.75 bar, 25 psi)

Output signal

20 to 100 kPa/0.2 to 1 bar, 3 to 15 psi or 0.2 to 1 kg/cm²

Static air consumption

350 NI/h

Maximum output flow

- with rising output pressure: 30 NI/min.
- with falling output pressure: 40 NI/min.

Accuracy

± 0.5% F.S.D. (typical)

Thermal drift (for ambient temperature variation between -20° C and +65° C)

- with 2in diaphragm
 - span 30 to 80 kPa (300 to 800 mbar): 0.4%/10°C
 - span 80 to 170 kPa (800 to 1700 mbar): 0.3%/10°C
- with 3in diaphragm
 - span 5 to 10 kPa (50 to 100 mbar): 0.6%/10°C
 - span 10 to 52 kPa (100 to 520 mbar): 0.4%/10°C

Maximum displacement

- with 2in diaphragm: 1 cm³
- with 3in diaphragm: 1.5 cm³

Degree of protection in accordance with IEC 529

IP55

Ambient temperature limits

-40 and + 120°C

Bodies material

Carbon steel, Monel (*), AISI 316L (*), Hastelloy C (*),

(*) Only the positive halfbody

Body bolts and nuts material

High tensile carbon steel;
AISI 316 Class A4-50 per ISO3506, in compliance with NACE MR0175

Cover material

thermoplastic resin

Diaphragm material

AISI 316L, Monel (*), Hastelloy C (*)

(*) Maximum overrange pressure reduced to 1MPa (10 bar)

Gaskets material

PTFE, Viton

Surface protections

- carbon steel body and flange: zinc plating and chrome passivation
- AISI 316L body and flange: no protection

Process connections (see figure ref. D)

- on flange: 1/2 in NPT-F
- on adapter: 1/4 in NPT-F
- center distance: 54 mm.

Pneumatic connections

- Air supply (in figure ref. A): 1/4 in NPT-F
- Output (in figure ref. B): 1/4 in NPT-F

Pressure gauge

Brass with stainless steel case (all stainless steel on request)
external diameter 51 mm; 0-200 kPa, 0-2 bar and 0-30 psi
indication on 82 mm/260° scale.

Air filter regulator

with copper or stainless steel piping, as specified.
Die cast aluminium alloy with light grey epoxy finish.

Net weight (maximum)

10 kg approx

Packing

expanded polythene box

ORDERING INFORMATION

Select one character or set of characters from each category and specify complete catalog number.

PRODUCT CODE

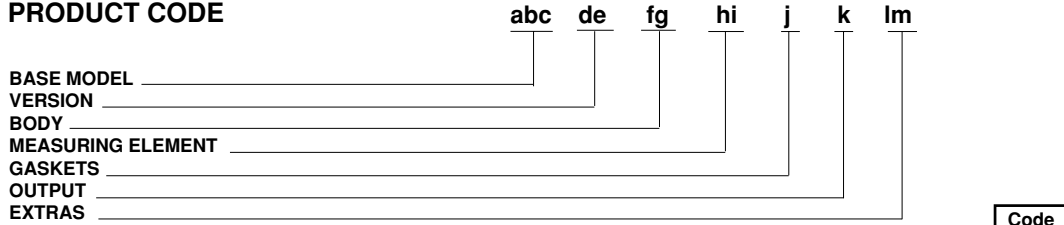

abc	BASE MODEL	Absolute pressure transmitter	NBC
------------	-------------------	-------------------------------	------------

de	VERSION	Standard with body bolts and nuts in high tensile carbon steel	01
		Standard with body bolts and nuts in AISI 316	11

fg	BODY	Positive side	Negative side	
		Carbon steel	Carbon steel	01
		Monel	AISI 316L	21
		AISI 316L	AISI 316L	41
		Hastelloy C	AISI 316L	51

hi	MEASURING ELEMENT	Diaphragm material	Core material	Capsule diameter	Span limits kPa (mmHg) - (Note 1)	
		AISI 316L	AISI 316L (*) (Note 2)	3 in	5 and 52 (37.5 and 390)	04
		AISI 316L	AISI 316L (*) (Note 2)	2 in	30 and 170 (225 and 1275)	05
		AISI 316L	AISI 316L (*) (Note 2)	3 in	2.5 and 7.5 (18.7 and 56.2)	06
		Monel	Monel (**)	3 in	5 and 52 (37.5 and 390)	21
		Monel	Monel (**)	2 in	30 and 170 (225 and 1275)	22
		Monel	Monel (**)	3 in	2.5 and 7.5 (18.7 and 56.2)	23
		AISI 316L	AISI 316L (Note 2)	3 in	5 and 52 (37.5 and 390)	41
		AISI 316L	AISI 316L (Note 2)	2 in	30 and 170 (225 and 1275)	42
		AISI 316L	AISI 316L (Note 2)	3 in	2.5 and 7.5 (18.7 and 56.2)	43
		Hastelloy C	Hastelloy C (**)	3 in	5 and 52 (37.5 and 390)	51
		Hastelloy C	Hastelloy C (**)	2 in	30 and 170 (225 and 1275)	52
		Hastelloy C	Hastelloy C (**)	3 in	2.5 and 7.5 (18.7 and 56.2)	53
		Hastelloy C	AISI 316L (**)	3 in	5 and 52 (37.5 and 390)	54
		Hastelloy C	AISI 316L (**)	2 in	30 and 170 (225 and 1275)	55
		Hastelloy C	AISI 316L (**)	3 in	2.5 and 7.5 (18.7 and 56.2)	56

Note 1: Multiply by 10 the value in kPa (MPa) to obtain mbar (bar).

Note 2: Hastelloy C for some wetted parts.

(*) Suitable for oxygen service (operating temperature limits reduced: -20°C to + 40°C; -4°F to 104°F)

(**) Maximum overrange reduced to 1 MPa (145 psi)

j	GASKETS	Flange gasket	Capsule gasket	Fulcrum diaphragm gasket	
		Viton	Viton	Viton	4
		PTFE (*)	PTFE (*)	PTFE (*)	5

(*) Suitable for oxygen service.

k	OUTPUT		
	3 to 15 psi	According to ANSI/ISA S 51.1-1979 standard terminology	1
	3 to 15 psi with zero suppression device		3
	0.2 to 1.0 kg/cm ²		4
	0.2 to 1.0 kg/cm ² with zero suppression device		6
	20 to 100 kPa / 0.2 to 1 bar		7
	20 to 100 kPa / 0.2 to 1 bar with zero suppression device		9

lm	EXTRAS	Identification tag material	Piping material	Air filter regulator	Pressure gauge	
		Stainless Steel	--	--	--	02
		Stainless Steel	Stainless Steel	with	--	10
		Stainless Steel	Copper	with	--	11
		Stainless Steel	Stainless Steel	with	with	13
		Stainless Steel	Copper	with	with	14

MOUNTING DIMENSIONS

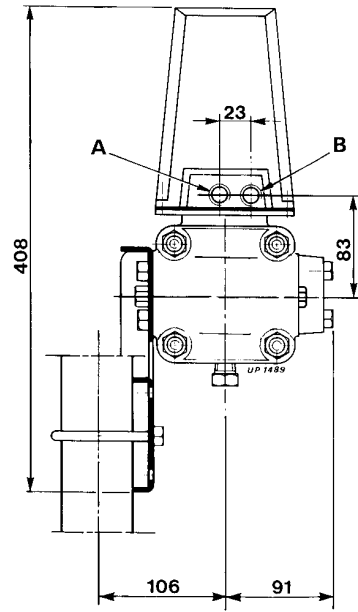
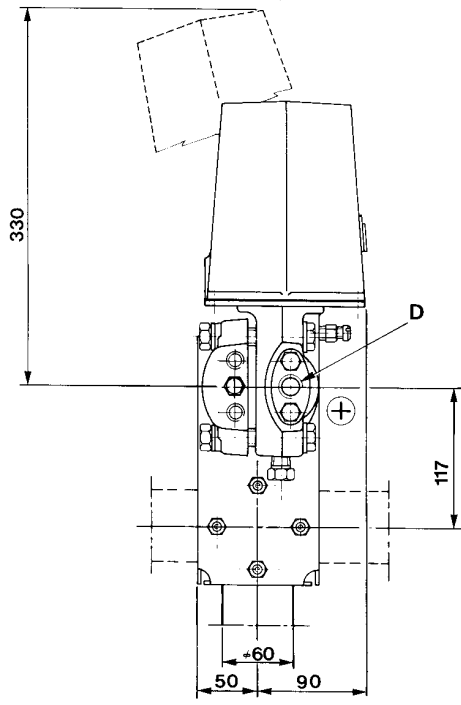

Contact us

ABB Ltd.

Process Automation

Howard Road
St. Neots
Cambridgeshire PE19 8EU
UK
Tel: +44 (0)1480 475321
Fax: +44 (0)1480 217948

ABB Inc.

Process Automation

125 E. County Line Road
Warminster
PA 18974
USA
Tel: +1 215 674 6000
Fax: +1 215 674 7183

ABB Automation Products GmbH

Process Automation

Schillerstr. 72
32425 Minden
Germany
Tel: +49 551 905 534
Fax: +49 551 905 555

ABB S.p.A.

Process Automation

Via Statale 113
22016 Lenno (CO)
Italy
Tel: +39 0344 58111
Fax: +39 0344 56278

www.abb.com

Note

We reserve the right to make technical changes or modify the contents of this document without prior notice. With regard to purchase orders, the agreed particulars shall prevail. ABB does not accept any responsibility whatsoever for potential errors or possible lack of information in this document.

We reserve all rights in this document and in the subject matter and illustrations contained therein. Any reproduction, disclosure to third parties or utilization of its contents - in whole or in parts - is forbidden without prior written consent of ABB.

Copyright© 2011 ABB
All rights reserved

3KXP900205R1001