

Model 266DHH Differential flange mounted

2600T Series Pressure Transmitters Engineered solutions for all applications



Base accuracy

- from 0.06 % of calibrated span

Reliable sensing system coupled with very latest digital technologies

- provides large turn down ratio up to 100:1

Comprehensive sensor choice

- optimize in-use total performance and stability

10-year stability

- 0.15 % of URL

Flexible configuration facilities

- provided locally via local LCD keypad

New TTG (Through-The-Glass) keypad technology

- allows quick and easy local configuration without opening the cover, even in explosion proof environments

IEC 61508 certification

- for SIL2 (1001) and SIL3 (1002) applications

Full compliance with PED Category III

Model 266DHH Differential flange mounted

Functional Specifications

Range and span limits

Sensor Code	Upper Range Limit (URL)	Lower Range Limit (LRL)	Minimum span
E	16 kPa	-16 kPa	0.54 kPa
	160 mbar	-160 mbar	5.4 mbar
	64 inH2O	-64 inH2O	2.16 inH2O
F	40 kPa	-40 kPa	0.4 kPa
	400 mbar	-400 mbar	4 mbar
	160 inH2O	-160 inH2O	1.6 inH2O
G	65 kPa	-65 kPa	0.65 kPa
	650 mbar	-650 mbar	6.5 mbar
	260 inH2O	-260 inH2O	2.6 inH2O
H	160 kPa	-160 kPa	1.6 kPa
	1600 mbar	-1600 mbar	16 mbar
	642 inH2O	-642 inH2O	6.4 inH2O
M	600 kPa	-600 kPa	6 kPa
	6 bar	-6 bar	0.06 bar
	87 psi	-87 psi	0.87 psi
P	2400 kPa	-2400 kPa	24 kPa
	24 bar	-24 bar	0.24 bar
	348 psi	-348 psi	3.5 psi

Span limits

Maximum span = URL (can be further adjusted up to \pm URL (TD = 0.5) for differential models, within the range limits)
IT IS RECOMMENDED TO SELECT THE TRANSMITTER SENSOR CODE PROVIDING THE TURNDOWN VALUE AS LOWEST AS POSSIBLE TO OPTIMIZE PERFORMANCE CHARACTERISTICS.

Zero suppression and elevation

Zero and span can be adjusted to any value within the range limits detailed in the table as long as:

- calibrated span \geq minimum span

Damping

Selectable time constant : between 0 and 60 s

This is in addition to sensor response time.

Turn on time

Operation within specification in less than 10 s with minimum damping.

Insulation resistance

> 100 M Ω at 500 V DC (terminals to earth)

Operative limits

Pressure limits:

Overpressure limits

Without damage to the transmitter

Flange	Fill fluid	Overpressure limits
ASME B16.5 Class 150	Silicone oil	0.07 kPa abs, 0.7 mbar abs, 0.5 mmHg and 230 psi
ASME B16.5 Class 300	Silicone oil	0.07 kPa abs, 0.7 mbar abs, 0.5 mmHg and 600 psi
EN 1092-1 PN 16	Silicone oil	0.07 kPa abs, 0.7 mbar abs, 0.5 mmHg and 13.5 bar
EN 1092-1 PN 40	Silicone oil	0.07 kPa abs, 0.7 mbar abs, 0.5 mmHg and 33.8 bar
ASME B16.5 Class 150	Inert (Galden)	0.135 kPa abs, 1.35 mbar abs, 1 mmHg and 230 psi
ASME B16.5 Class 300	Inert (Galden)	0.135 kPa abs, 1.35 mbar abs, 1 mmHg and 600 psi
EN 1092-1 PN 16	Inert (Galden)	0.135 kPa abs, 1.35 mbar abs, 1 mmHg and 13.5 bar
EN 1092-1 PN 40	Inert (Galden)	0.135 kPa abs, 1.35 mbar abs, 1 mmHg and 33.8 bar
ASME B16.5 Class 150	Inert (Halocarbon)	0.4 kPa abs, 4 mbar abs, 3 mmHg and 230 psi
ASME B16.5 Class 300	Inert (Halocarbon)	0.4 kPa abs, 4 mbar abs, 3 mmHg and 600 psi
EN 1092-1 PN 16	Inert (Halocarbon)	0.4 kPa abs, 4 mbar abs, 3 mmHg and 13.5 bar
EN 1092-1 PN 40	Inert (Halocarbon)	0.4 kPa abs, 4 mbar abs, 3 mmHg and 33.8 bar

Static pressure limits

Transmitters for differential pressure model 266DHH operates within specifications between the following limits:

Flange	Static pressure limits
ASME B16.5 Class 150	1.3 kPa abs, 13 mbar abs, 0.2 psia and 230 psi
ASME B16.5 Class 300	1.3 kPa abs, 13 mbar abs, 0.2 psia and 600 psi
EN 1092-1 PN 16	1.3 kPa abs, 13 mbar abs, 0.2 psia and 13.5 bar
EN 1092-1 PN 40	1.3 kPa abs, 13 mbar abs, 0.2 psia and 33.8 bar

The pressure limit decreases with increasing temperature above 100°F (38°C), according to ASME B16.5 standards or above 50°C according to EN 1092-1 standards.

Proof pressure

The transmitter can be exposed without leaking to line pressure of up to two times the flange rating.

Meet ANSI/ISA-S 82.03 hydrostatic test requirements.

Temperature limits °C (°F) :

Ambient

is the operating temperature

Model 266DHH	Ambient temperature limits
Silicone oil for sensor F to P	-40 and 85 °C (-40 and 185 °F)
Silicone oil for sensor E	-25 and 85 °C (-13 and 185 °F)
Inert (Galden) for sensor F to P	-20 and 85 °C (-4 and 185 °F)
Inert (Galden) for sensor E	-10 and 85 °C (14 and 185 °F)
Inert (Halocarbon) for sensor F to P	-20 and 85 °C (-4 and 185 °F)
Inert (Halocarbon) for sensor E	-10 and 85 °C (14 and 185 °F)

Model 266DHH	Ambient temperature limits
LCD integral display	-40 and 85 °C (-40 and 185 °F)

LCD display may not be clearly readable below -20 °C (-4 °F) or above +70 °C (+158 °F)

IMPORTANT

For Hazardous Atmosphere applications see the temperature range specified on the certificate/approval relevant to the aimed type of protection

Process

Model 266DHH	Process temperature limits
Silicone oil for sensor F to P	-40 and 121 °C (-40 and 250 °F) ⁽¹⁾
Silicone oil for sensor E	-25 and 121 °C (-13 and 250 °F) ⁽¹⁾
Inert (Galden) for sensor F to P	-20 and 100 °C (-4 and 212 °F) ⁽²⁾
Inert (Galden) for sensor E	-10 and 100 °C (14 and 212 °F) ⁽²⁾
Inert (Halocarbon) for sensor F to P	-20 and 100 °C (-4 and 212 °F) ⁽²⁾
Inert (Halocarbon) for sensor E	-10 and 100 °C (14 and 212 °F) ⁽²⁾

Model 266DHH	Process temperature limits
Viton gasket	-20 and 121 °C (-4 and 250 °F)

Storage

Model 266DHH	Storage temperature limits
Storage limits	-50 and 85 °C (-58 and 185 °F)
LCD integral display	-40 and 85 °C (-40 and 185 °F)

Model 266DHH Differential flange mounted

Environmental limits

Electromagnetic compatibility (EMC)

Comply with EN 61326 and NAMUR NE-21
Surge immunity level (with surge protector): 4 kV
(according to IEC 1000-4-5 EN 61000-4-5)

Pressure equipment directive (PED)

Comply with 97/23/EEC Category III Module H.

Humidity

Relative humidity: up to 100 %
Condensing, icing: admissible

Vibration resistance

Accelerations up to 2 g at frequency up to 1000 Hz
(according to IEC 60068-2-6)

Shock resistance

Acceleration: 50 g
Duration: 11 ms
(according to IEC 60068-2-27)

Wet and dust-laden atmospheres

The transmitter is dust and sand tight and protected against immersion effects as defined by EN 60529 (1989) to IP 67 (IP 68 on request) or by NEMA to 4X or by JIS to C0920. IP65 with Harting Han connector.

Hazardous atmospheres

With or without integral display

INTRINSIC SAFETY:

ATEX Europe (code E1) and IEC Ex (code E8) approval

II 1 G Ex ia IIC T6 and

II 1/2 G Ex ia IIC T6 (-40 °C ≤ Ta ≤ +40 °C);

II 1 D Ex iaD 20 T 95 °C and

II 1/2 D Ex iaD 21 T95 °C

EXPLOSION PROOF:

ATEX Europe (code E2) and IEC Ex (code E9) approval

II 1/2 G Ex d IIC T6 and

II 1/2 D Ex tD A21 IP67 T85 °C

TYPE "N":

ATEX Europe (code E3) and IEC Ex (code ER)

type examination

II 3 G Ex nL IIC T6 and

II 3 D Ex tD A22 IP67 T85 °C

FM Approvals US (code E6) and

FM Approvals Canada (code E4):

- Explosionproof (US): Class I, Div. 1, Groups A, B, C, D

- Explosionproof (Canada): Class I, Div. 1, Groups B, C, D

- Dust ignitionproof : Class II, Div. 1, Groups E, F, G

- Suitable for: Class II, Div. 2, Groups F, G; Class III, Div.1, 2

- Nonincendive: Class I, Div. 2, Groups A, B, C, D

- Intrinsically safe: Class I, II, III, Div. 1, Groups A, B, C, D, E, F, G

Class I, Zone 0 AEx ia IIC T6/T4, Zone 0 (FM US)

Class I, Zone 0 Ex ia IIC T6/T4, Zone 0 (FM Canada)

COMBINED ATEX (code EW = E1 + E2 + E3)

COMBINED ATEX and FM Approvals (code EN = EW + E4 + E6)

COMBINED FM Approvals US and Canada

- Intrinsically safe (code EA)

- Explosionproof (code EB)

- Nonincendive (code EC)

- GOST (Russia), GOST (Kazakhstan), Inmetro (Brazil)

based on ATEX

Electrical Characteristics and Options

HART digital communication and 4 to 20 mA output Power Supply

The transmitter operates from 10.5 to 42 V DC with no load and is protected against reverse polarity connection (additional load allows operations over 42 V DC).

For EEx ia and other intrinsically safe approval power supply must not exceed 30 V DC.

Minimum operating voltage increase to 12.3 V DC with optional surge protector

Ripple

20 mV max on a 250 Ω load as per HART specifications.

Load limitations

4 to 20 mA and HART total loop resistance :

$$R \text{ (k}\Omega\text{)} = \frac{\text{Supply voltage} - \text{min. operating voltage (V DC)}}{22 \text{ mA}}$$

A minimum of 250 Ω is required for HART communication.

Optional indicators

Integral display (code L1)

Wide screen LCD, 128 x 64 pixel,

52.5 x 27.2 mm (2.06 x 1.07 in.) dot matrix. Multilanguage.

Four keys for configuration and management of device.

Easy setup for quick commissioning.

User selectable application-specific visualizations.

Totalized and instantaneous flow indication.

Display may also indicate static pressure, sensor temperature and diagnostic messages and provides configuration facilities.

Through-the-glass (TTG) controlled display (code L5)

As above integral display but equipped with the innovative TTG keypad allowing the activation of the configuration and management menus of the device without the need of removing the transmitter housing cover.

TTG keypad is protected against accidental activations.

Optional surge protection

Up to 4kV

– voltage 1.2 μ s rise time / 50 μ s delay time to half value

– current 8 μ s rise time / 20 μ s delay time to half value

Output signal

Two-wire 4 to 20 mA, user-selectable for linear or square root output, power of $\sqrt[3]{2}$ or $\sqrt[5]{2}$, square root for bidirectional flow, 22 points linearization table (i.e. for horizontal or spherical tank level measurement).

HART[®] communication provides digital process variable superimposed on 4 to 20 mA signal, with protocol based on Bell 202 FSK standard.

Output current limits (to NAMUR standard)

Overload condition

- Lower limit: 3.8 mA (configurable from 3.8 to 4 mA)

- Upper limit: 20.5 mA (configurable from 20 to 21 mA)

Alarm current

- Lower limit: 3.6 mA (configurable from 3.6 to 4 mA)

- Upper limit: 21 mA (configurable from 20 to 22 mA)

Factory setting: high alarm current

Process diagnostics (PILD)

Plugged impulse line detection (PILD) generates a warning via HART communication. The device can also be configured to drive the analog output signal to the "Alarm current".



Model 266DHH Differential flange mounted

FOUNDATION Fieldbus output

Device type

LINK MASTER DEVICE

Link Active Scheduler (LAS) capability implemented.

Manufacturer code: 000320 (hex)

Device type code: 0007 (hex)

Power supply

The transmitter operates from 9 to 32 V DC, polarity independent, with or without surge protector.

For EEx ia approval power supply must not exceed 24 V DC (entity certification) or 17.5 V DC (FISCO certification), according to FF-816.

Current consumption

operating (quiescent): 15 mA

fault current limiting: 20 mA max.

Output signal

Physical layer in compliance to IEC 1158-2/EN 61158-2 with transmission to Manchester II modulation, at 31.25 kbit/s.

Function blocks/execution period

3 enhanced Analog Input blocks/25 ms max (each)

1 enhanced PID block/40 ms max.

1 standard ARithmetic block/25 ms

1 standard Input Selector block/25 ms

1 standard Control Selector block/25 ms

1 standard Signal Characterization block/25 ms

1 standard Integrator/Totalizer block/25 ms

Additional blocks

1 enhanced Resource block,

1 custom Pressure with calibration transducer block

1 custom Advanced Diagnostics transducer block including

Plugged Input Line Detection

1 custom Local Display transducer block

Number of link objects

35

Number of VCRs

35

Output interface

FOUNDATION fieldbus digital communication protocol to standard H1, compliant to specification V. 1.7.

Integral display

Wide screen LCD, 128 x 64 pixel,

52.5 x 27.2 mm (2.06 x 1.07 in.) dot matrix. Multilanguage.

Four keys for configuration and management of device.

Easy setup for quick commissioning.

User selectable application-specific visualizations.

Totalized and instantaneous flow indication.

Display may also indicate static pressure, sensor temperature and diagnostic messages and provides configuration facilities.

Transmitter failure mode

The output signal is "frozen" to the last valid value on gross transmitter failure condition, detected by self-diagnostics which also indicate a BAD conditions. If electronic failure or short circuit occur the transmitter consumption is electronically limited at a defined value (20 mA approx), for safety of the network.

PROFIBUS PA output

Device type

Pressure transmitter compliant to Profiles 3.0.1

Identification number: 3450 (hex)

Power supply

The transmitter operates from 9 to 32 V DC, polarity independent, with or without surge protector.

For EEx ia approval power supply must not exceed 17.5 V DC.

Intrinsic safety installation according to FISCO model.

Current consumption

operating (quiescent): 15 mA

fault current limiting: 20 mA max.

Output signal

Physical layer in compliance to IEC 1158-2/EN 61158-2 with transmission to Manchester II modulation, at 31.25 kbit/s.

Output interface

PROFIBUS PA communication according to Profibus DP50170 Part 2/DIN 19245 part 1-3.

Output update time

25 ms

Function blocks

3 analog input, 3 transducer, 1 physical.

Integral display

Wide screen LCD, 128 x 64 pixel,

52.5 x 27.2 mm (2.06 x 1.07 in.) dot matrix. Multilanguage.

Four keys for configuration and management of device.

Easy setup for quick commissioning.

User selectable application-specific visualizations.

Instantaneous flow indication.

Display may also indicate static pressure, sensor temperature and diagnostic messages and provides configuration facilities.

Transmitter failure mode

On gross transmitter failure condition, detected by self-diagnostics, the output signal can be driven to defined conditions, selectable by the user as safe, last valid or calculated value.

If electronic failure or short circuit occur the transmitter consumption is electronically limited at a defined value (20 mA approx), for safety of the network.

Performance specifications

Stated at reference condition to IEC 60770 ambient temperature of 20 °C (68 °F), relative humidity of 65 %, atmospheric pressure of 1013 hPa (1013 mbar), mounting position with vertical diaphragm and zero based range for transmitter with isolating diaphragms in AISI 316 L ss or Hastelloy and silicone oil fill and HART digital trim values equal to 4 mA and to 20 mA span end points, in linear mode. Unless otherwise specified, errors are quoted as % of span. Some performance referring to the Upper Range Limit are affected by the actual turndown (TD) as ratio between Upper Range Limit (URL) and calibrated span.

IT IS RECOMMENDED TO SELECT THE TRANSMITTER SENSOR CODE PROVIDING THE TURNDOWN VALUE AS LOWEST AS POSSIBLE TO OPTIMIZE PERFORMANCE CHARACTERISTICS.

Dynamic performance (according to IEC 61298-1 definition)

Sensors	Time constant (63.2 % of total step change)
Sensor M and P	≤ 70 ms
Sensor H	100 ms
Sensor G	130 ms
Sensor F	180 ms
Dead time for all sensors	30 ms

Response time (total) = dead time + time constant

Accuracy rating

% of calibrated span, including combined effects of terminal based linearity, hysteresis and repeatability.

For fieldbus versions SPAN refer to analog input function block outscale range

Model	Sensor	for TD up to	
266DHH	F and G	from 1:1 to 10:1	± 0.06 %
	F and G	from 10:1 to 100:1	± 0.025 + (0.0035 x TD) %
	H to P	from 1:1 to 10:1	± 0.075 %
	H to P	from 10:1 to 100:1	± (0.0075 x TD) %
	E	from 1:1 to 10:1	± 0.075 %
	E	from 10:1 to 30:1	± (0.0075 x TD) %

Model 266DHH Differential flange mounted

Ambient temperature

per 20K change between the limits of $-40\text{ }^{\circ}\text{C}$ to $+85\text{ }^{\circ}\text{C}$
(per $36\text{ }^{\circ}\text{F}$ change between the limits of -40 to $+185\text{ }^{\circ}\text{F}$):

Model	Sensor	for TD up to	
266DHH	F to P	10:1	$\pm (0.03\% \text{ URL} + 0.045\% \text{ span})$
	E	10:1	$\pm (0.04\% \text{ URL} + 0.065\% \text{ span})$

for an ambient temperature change from $-10\text{ }^{\circ}\text{C}$ to $+60\text{ }^{\circ}\text{C}$
($+14$ to $+140\text{ }^{\circ}\text{F}$):

Model	Sensor	for TD up to	
266DHH	F to P	10:1	$\pm (0.055\% \text{ URL} + 0.08\% \text{ span})$
	E	10:1	$\pm (0.075\% \text{ URL} + 0.11\% \text{ span})$

per 10K change between the limits of $-40\text{ }^{\circ}\text{C}$ to $-10\text{ }^{\circ}\text{C}$ or
 $+60\text{ }^{\circ}$ to $+85\text{ }^{\circ}\text{C}$ (per $18\text{ }^{\circ}\text{F}$ change between the limits of -40
to $+14\text{ }^{\circ}\text{F}$ or $+140\text{ }^{\circ}$ to $+185\text{ }^{\circ}\text{F}$):

Model	Sensor	for TD up to	
266DHH	F to P	10:1	$\pm (0.03\% \text{ URL} + 0.04\% \text{ span})$
	E	10:1	$\pm (0.04\% \text{ URL} + 0.055\% \text{ span})$

Static pressure

(zero errors can be calibrated out at line pressure)

per 2 MPa, 20 bar or 290 psi

Model 266DHH

– zero error: $\pm 0.05\%$ of URL for sensor F to P

$\pm 0.08\%$ of URL for sensor E

– span error: $\pm 0.08\%$ of reading.

Supply voltage

Within voltage/load specified limits the total effect is less than
 0.005% of URL per volt.

Load

Within load/voltage specified limits the total effect is negligible.

Electromagnetic field

Meets all the requirements of EN 61326 and NAMUR NE-21.

Common mode interference

No effect from 100Vrms @ 50Hz, or 50 V DC

Mounting position

No effect for rotation on diaphragm plane. A tilt up to 90° from
vertical causes a zero shifts up to 0.5 kPa, 5 mbar or 2 inH₂O,
which can be corrected with zero adjustment. No span effect.

Stability

$\pm 0.15\%$ of URL over a ten years period

Physical Specification

(Refer to ordering information sheets for variant availability related to specific model or versions code)

Materials

Process isolating diaphragms (*)

AISI 316 L ss; Monel 400™; Tantalum; Hastelloy C-276™.

High pressure side process mounting flange

AISI 316 L ss with flushing connections

Low pressure side process flange, adapter, plug and drain/vent valve (*)

AISI 316 L ss; Hastelloy C-276™; Monel 400™.

Sensor fill fluid

Silicone oil; Inert fill (Halocarbon™ 4.2 or Galden™).

Mounting bracket (**)

Zinc plated carbon steel with chrome passivation; AISI 316 L ss.

Gaskets (*)

Viton™; PTFE.

Sensor housing

AISI 316 L ss.

Bolts and nuts

AISI 316 ss bolts and nuts Class A4–50 per UNI 7323 (ISO 3506), in compliance with NACE MR0175 Class II.

Electronic housing and covers

Aluminium alloy (copper content $\leq 0.3\%$) with baked epoxy finish (colour RAL9002);

AISI 316 L ss.

Covers O-ring

Buna N.

Local adjustments (zero, span and write protect)

Glass filled polyphenylene oxide (removable).

Plates

AISI 316ss for transmitter nameplate, certification plate, optional tag/calibration plate attached to the electronics housing and optional wired-on customer data plate. All printing by laser.

Calibration

Standard: at maximum span, zero based range, ambient temperature and pressure;

Optional: at specified range and ambient conditions.

(*) Wetted parts of the transmitter.

(**) Bolts and nuts, gasket and mating flange supplied by customer.

Optional extras

Display

4-position (at 90°) user orientable.

Optional plates

Code I2: for tag (up to 31 characters) and calibration details (up to 31 characters: lower and upper values plus unit) fixed onto transmitter housing.

Code I1: for customer data (32 character x 4 lines) wired-on transmitter housing

Surge protection

Test Certificates (test, design, calibration, material traceability)

Tag and manual language

Communication connectors

Process connections

Low pressure side :

on flanges : $1/4$ – 18 NPT on process axis

on adapters : $1/2$ – 14 NPT on process axis

fixing threads: $7/16$ – 20 UNF at 41.3 mm centre distance

High pressure side (**):

2 in. or 3 in., ASME Class 150 or Class 300 RF;

DN 50 or DN 80, PN 16 or PN 40 to EN 1092-1 Type B1

Electrical connections

Two $1/2$ – 14 NPT or M20x1.5 threaded conduit entries, direct on housing.

Special communication connector (on request)

– HART : straight or angle Harting Han 8D connector and one plug.

– FOUNDATION Fieldbus, PROFIBUS PA: M12x1 or 7/8 in.

Terminal block

HART version: three terminals for signal/external meter wiring up to 2.5 mm² (14 AWG), also connection points for test and communication purposes.

Fieldbus versions: two terminals for signal wiring (bus connection) up to 2.5 mm² (14 AWG)

Grounding

Internal and external 6 mm² (10 AWG) ground termination points are provided.

Mounting position

Transmitter can be mounted in any position.

Electronics housing may be rotated to any position. A positive stop prevents over travel.

Mass (without options)

7 to 11 kg approx (16 to 24 lb); add 1.5 kg (3.3 lb) for AISI housing.

Add 650 g (1.5 lb) for packing.

Packing

Carton 35 x 33 x 35cm approx (14 x 13 x 14in).

Model 266DHH Differential flange mounted

Configuration

Transmitter with HART communication and 4 to 20 mA Standard configuration

Transmitters are factory calibrated to customer's specified range. Calibrated range and tag number are stamped on the tag plate. If a calibration range and tag data are not specified, the transmitter will be supplied with the plate left blank and configured as follows:

Engineering Unit	kPa
4 mA	Zero
20 mA	Upper Range Limit (URL)
Output	Linear
Damping	1 s
Transmitter failure mode	Upscale
Software tag (8 characters max)	Blank
Optional LCD display	PV in kPa; output in mA and in percentage on bargraph

Any or all the above configurable parameters, including Lower range-value and Upper range-value which must be the same unit of measure, can be easily changed using the HART hand-held communicator or by a PC running the configuration software with DTM for 266 models. The transmitter database is customized with specified flange type and material, O-ring and drain/vent materials and meter code option.

Custom configuration (option)

The following data may be specified in addition to the standard configuration parameters:

Descriptor	16 alphanumeric characters
Message	32 alphanumeric characters
Date	Day, month, year

For HART protocol available engineering units of pressure measure are :

Pa, kPa, MPa

inH₂O@4 °C, mmH₂O@4 °C, psi

inH₂O@20 °C, ftH₂O@20 °C, mmH₂O@20 °C

inHg, mmHg, Torr

g/cm², kg/cm², atm

mbar, bar

These and others are available for PROFIBUS and FOUNDATION Fieldbus.

Transmitter with PROFIBUS PA communication Standard configuration

Transmitters are factory calibrated to customer's specified range. Calibrated range and tag number are stamped on the tag plate. If a calibration range and tag data are not specified, the transmitter will be supplied with the plate left blank and configured as follows:

Measure Profile	Pressure
Engineering Unit	kPa
Output scale 0 %	Lower Range Limit (LRL)
Output scale 100 %	Upper Range Limit (URL)
Output	Linear
Hi-Hi Limit	Upper Range Limit (URL)
Hi Limit	Upper Range Limit (URL)
Low Limit	Lower Range Limit (LRL)
Low-Low Limit	Lower Range Limit (LRL)
Limits hysteresis	0.5 % of output scale
PV filter	0 s
Address (set by local key)	126
Tag	32 alphanumeric characters
Optional LCD display	PV in kPa; output in percentage on bargraph

Any or all the above configurable parameters, including the range values which must be the same unit of measure, can be easily changed by a PC running the configuration software with DTM for 266 models. The transmitter database is customized with specified flange type and material, O-ring and drain/vent materials and meter code option.

Custom configuration (option)

The following data may be specified in addition to the standard configuration parameters:

Descriptor	32 alphanumeric characters
Message	32 alphanumeric characters
Date	Day, month, year

Transmitter with FOUNDATION Fieldbus communication

Standard configuration

Transmitters are factory calibrated to customer's specified range. Calibrated range and tag number are stamped on the tag plate. If a calibration range and tag data are not specified, the transmitter will be supplied with the plate left blank and the analog input function block FB1 is configured as follows:

Measure Profile	Pressure
Engineering Unit	kPa
Output scale 0 %	Lower Range Limit (LRL)
Output scale 100 %	Upper Range Limit (URL)
Output	Linear
Hi-Hi Limit	Upper Range Limit (URL)
Hi Limit :	Upper Range Limit (URL)
Low Limit	Lower Range Limit (LRL)
Low-Low Limit	Lower Range Limit (LRL)
Limits hysteresis	0.5 % of output scale
PV filter time	0 s
Tag	32 alphanumeric characters
Optional LCD display	PV in kPa; output in percentage on bargraph

The analog input function block FB2 and FB3 are configured respectively for the sensor temperature measured in °C and for the static pressure measured in MPa.

Any or all the above configurable parameters, including the range values, can be changed using any host compliant to FOUNDATION fieldbus. The transmitter database is customized with specified flange type and material, O-ring and drain/vent materials and meter code option.

Model 266DHH Differential flange mounted

MOUNTING DIMENSIONS (not for construction unless certified) – dimensions in mm (in.)

Transmitter with barrel housing

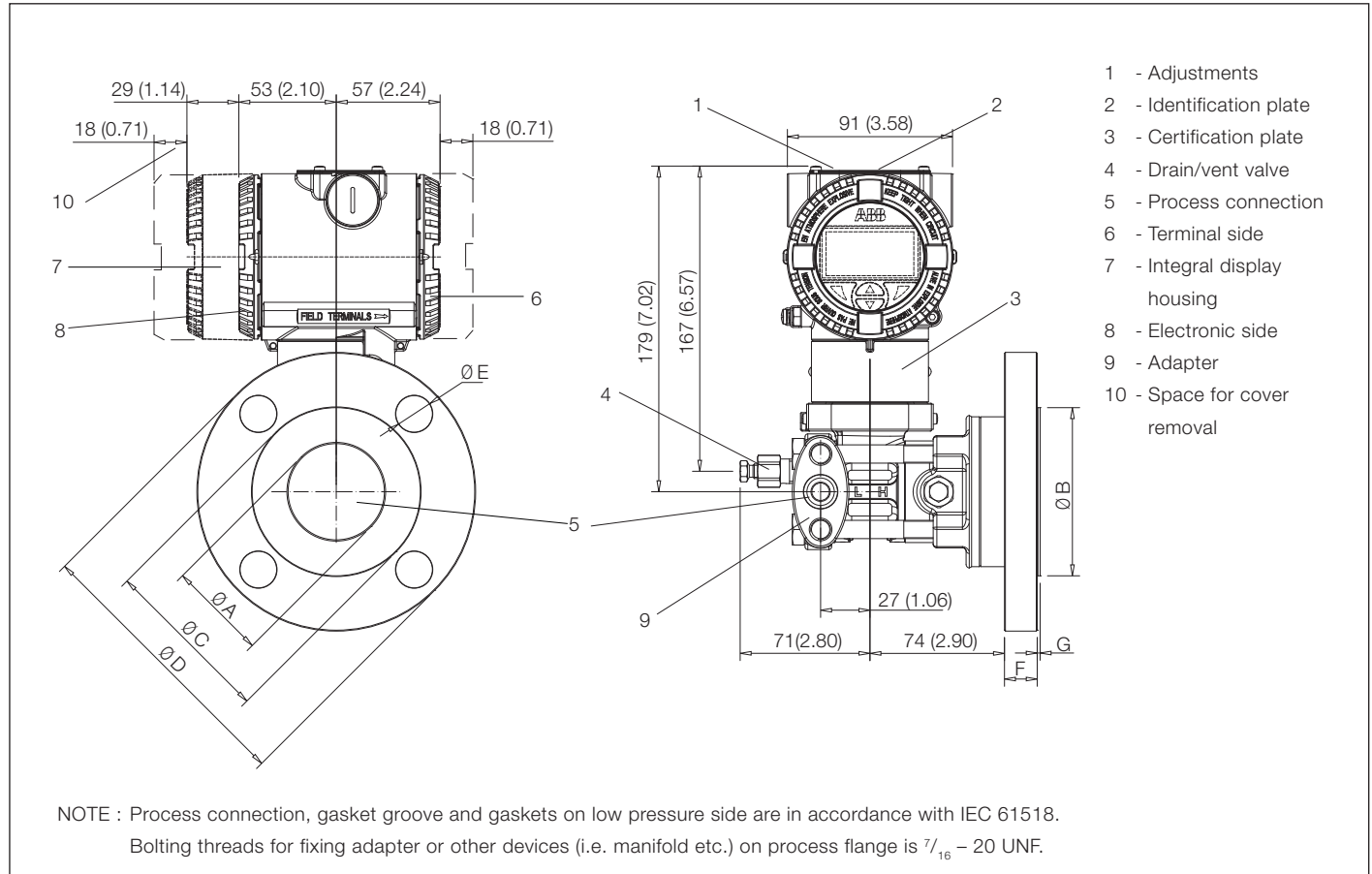

Transmitter with DIN aluminium housing

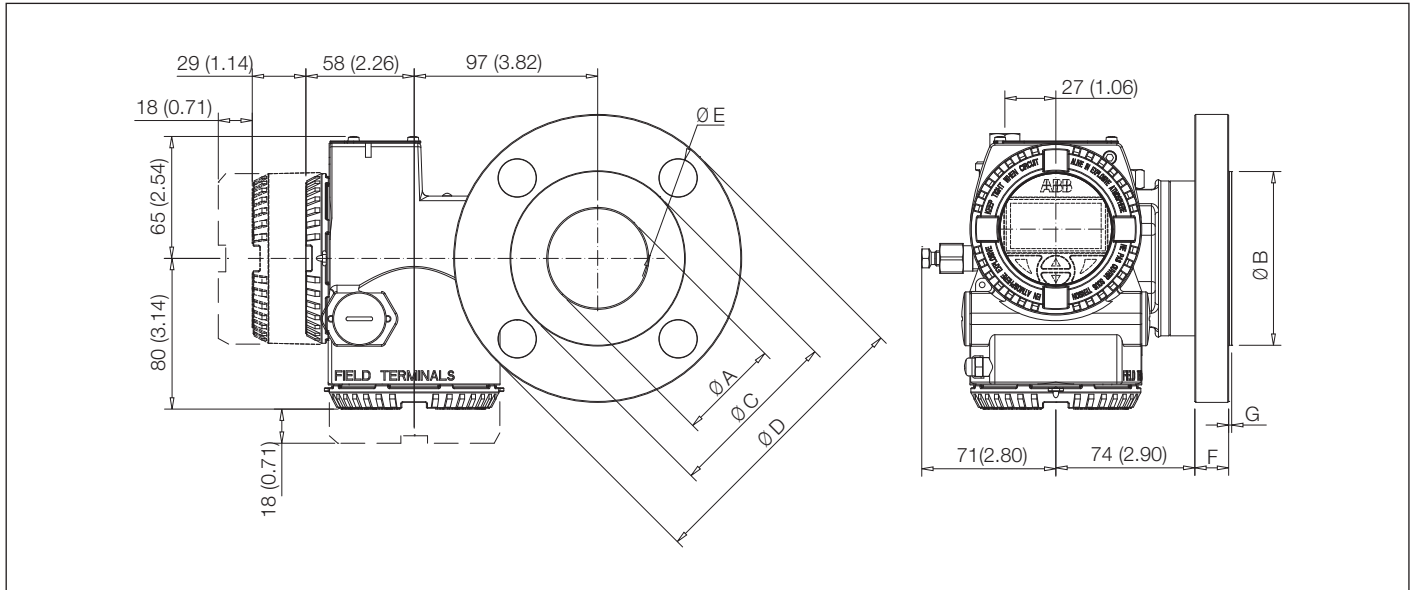

Rating	Size	Dimensions mm (in)							N° of holes
		A (dia)	B (dia)	C (dia)	D (dia)	E (dia)	F	G	
ASME Class 150 R.F.	2 in.	53 (2.09)	92 (3.62)	120.5 (4.74)	152.5 (6)	20 (0.79)	19.5 (0.77)	1.6 (0.07)	4
ASME Class 150 R.F.	3 in.	77 (3.04)	127 (5)	152.5 (6)	190.5 (7.5)	20 (0.79)	24 (0.94)	1.6 (0.07)	4
ASME Class 300 R.F.	2 in.	53 (2.09)	92 (3.62)	127 (5)	165 (6.5)	20 (0.79)	22.5 (0.89)	1.6 (0.07)	8
ASME Class 300 R.F.	3 in.	77 (3.04)	127 (5)	168.5 (6.63)	210 (8.26)	22 (0.86)	28.5 (1.12)	1.6 (0.07)	8
EN PN 16 Type B1	DN 50	53 (2.09)	102 (4.02)	125 (4.92)	165 (6.5)	18 (0.71)	20 (0.79)	3 (0.12)	4
EN PN 16 Type B1	DN 80	77 (3.04)	138 (5.43)	160 (6.3)	200 (7.87)	18 (0.71)	20 (0.79)	2 (0.08)	8
EN PN 40 Type B1	DN 50	53 (2.09)	102 (4.02)	125 (4.92)	165 (6.5)	18 (0.71)	20 (0.79)	3 (0.12)	4
EN PN 40 Type B1	DN 80	77 (3.04)	138 (5.43)	160 (6.3)	200 (7.87)	18 (0.71)	24 (0.94)	2 (0.08)	8

Model 266DHH Differential flange mounted

Electrical connections

HART Version

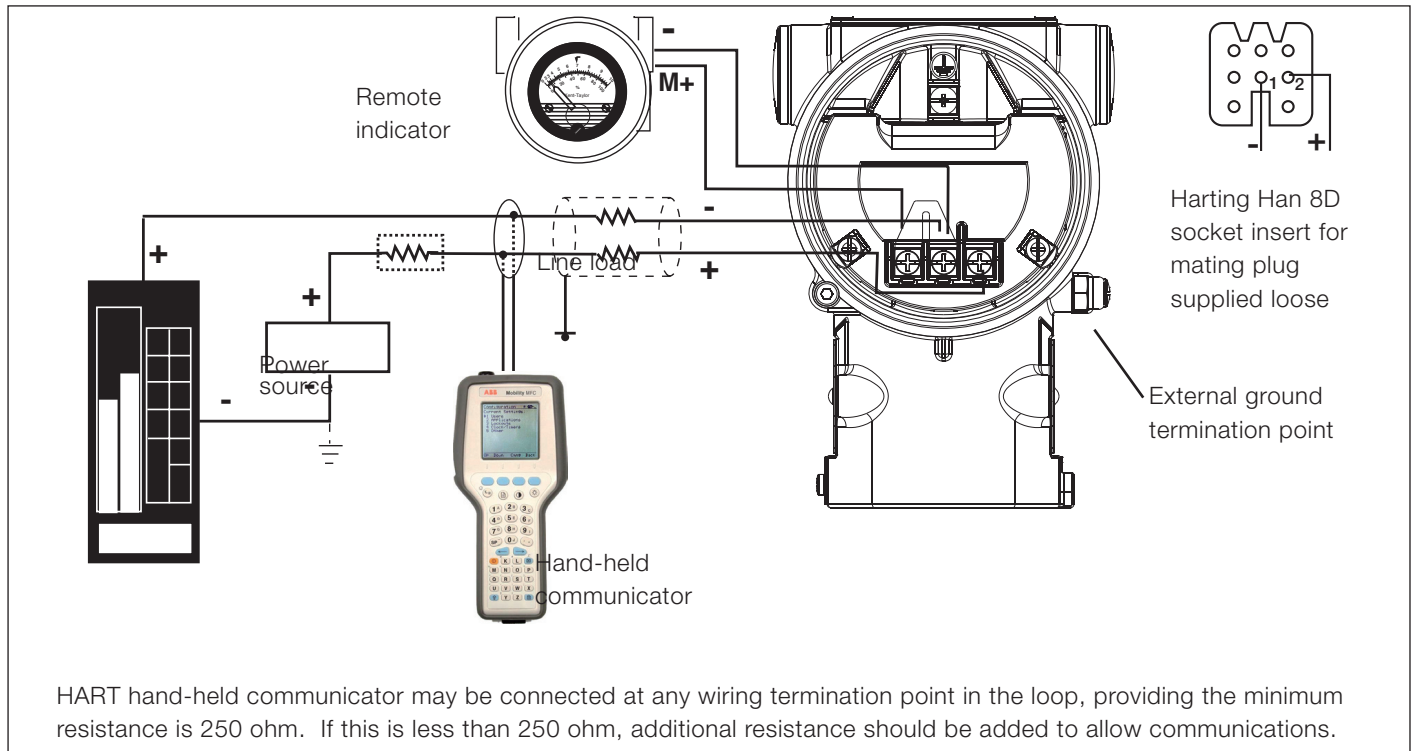

FIELDBUS Versions

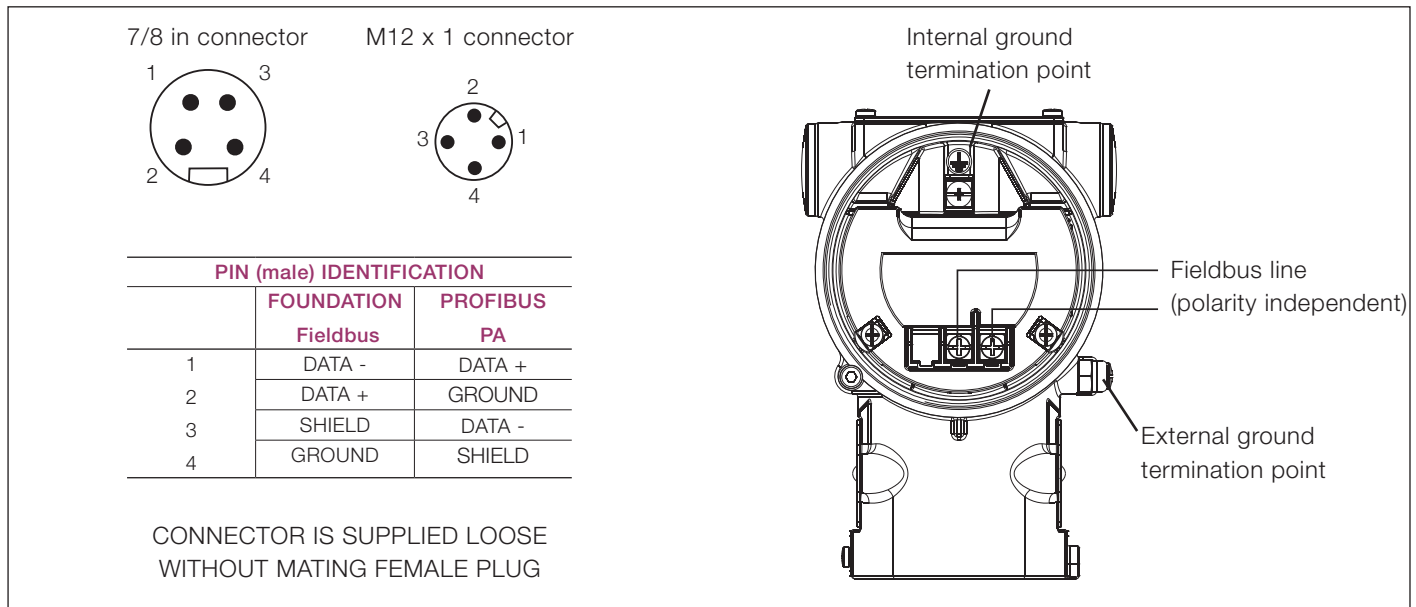

Ordering information

BASIC ORDERING INFORMATION model 266DHH Flange Mounted Differential Pressure Transmitter

Select one character or set of characters from each category and specify complete catalog number.

Refer to additional ordering information and specify one or more codes for each transmitter if additional options are required.

BASE MODEL - 1 st to 6 th characters				2	6	D	H	H	X	S	X	X	X	X	X	X	X	
Differential Pressure Transmitter – BASE ACCURACY 0.06 %																		
SENSOR - Span limits - 7 th characters																		
0.54 and 16 kPa	5.4 and 160 mbar	2.16 and 64 inH2O							E									
0.4 and 40 kPa	4 and 400 mbar	1.6 and 160 inH2O							F									
0.65 and 65 kPa	6.5 and 650 mbar	2.6 and 260 inH2O							G									
1.6 and 160 kPa	16 and 1600 mbar	6.4 and 642 inH2O							H									
6 and 600 kPa	0.06 and 6 bar	0.87 and 87 psi							M									
24 and 2400 kPa	0.24 and 24 bar	3.5 and 348 psi							P									
Use code - 8 th characters										S								
HIGH PRESSURE SIDE - Process mounting flange rating / Size - 9 th characters																		
ASME Class 150		2 in.																
ASME Class 150		3 in.																
ASME Class 300		2 in.																
ASME Class 300		3 in.																
EN PN 16 / 40		DN 50																
EN PN 16		DN 80																
EN PN 40		DN 80																
HIGH PRESSURE SIDE - Mounting flange material/seat form - 10 th characters																		
AISI 316 L ss	Form RF (raised face) - serrated finish	(Note 1)																
AISI 316 L ss	EN 1092-1 Type B1 - serrated finish	(Note 2)																
Diaphragm material / Fill fluid (wetted parts) - 11 th characters																		
AISI 316 L ss		Silicone oil																
Hastelloy C-276™		Silicone oil																
Monel 400™		Silicone oil																
Tantalum		Silicone oil																
AISI 316 L ss		Inert fluid - Galden	(Note 3)															
Hastelloy C-276™		Inert fluid - Galden	(Note 3)															
Monel 400™		Inert fluid - Galden	(Note 3)															
Tantalum		Inert fluid - Galden	(Note 3)															
AISI 316 L ss		Inert fluid - Halocarbon	(Note 3)															
Hastelloy C-276™		Inert fluid - Halocarbon	(Note 3)															
Monel 400™		Inert fluid - Halocarbon	(Note 3)															
Tantalum		Inert fluid - Halocarbon	(Note 3)															

continued
see next page

Model 266DHH Differential flange mounted

BASIC ORDERING INFORMATION model 266DHH Flange Mounted Differential Pres. Transmitter				2	6	D	H	H	X	S	X	X	X	X	X
Low side process flanges/adapters material and connection (wetted parts) - 12th characters															
AISI 316 L ss (Horizontal connection)	1/4 – 18 NPT-f direct		NACE										A		
AISI 316 L ss (Horizontal connection)	1/2 – 14 NPT-f through adapter		NACE										B		
Hastelloy C-276™ (Horizontal connection)	1/4 – 18 NPT-f direct	(Note 4)	NACE										D		
Hastelloy C-276™ (Horizontal connection)	1/2 – 14 NPT-f through adapter	(Note 4)	NACE										E		
Monel 400™ (Horizontal connection)	1/4 – 18 NPT-f direct	(Note 4)	NACE										G		
Monel 400™ (Horizontal connection)	1/2 – 14 NPT-f through adapter	(Note 4)	NACE										H		
Bolts/Gasket (wetted parts) - 13th characters															
AISI 316 ss (NACE) – (MWP = 16 MPa)	Viton™		NACE											3	
AISI 316 ss (NACE) – (MWP = 16 MPa)	PTFE	(Note 3)	NACE											4	
Housing material and electrical connection - 14th characters															
Aluminium alloy (barrel version)	1/2 – 14 NPT														A
Aluminium alloy (barrel version)	M20 x 1.5 (CM 20)														B
Aluminium alloy (barrel version)	Harting Han 8D connector	(general purpose only)										(Note 5)			E
Aluminium alloy (barrel version)	Fieldbus connector	(general purpose only)										(Note 5)			G
AISI 316 L ss (barrel version)	1/2 – 14 NPT														S
AISI 316 L ss (barrel version)	M20 x 1.5 (CM20)														T
AISI 316 L ss (barrel version)	Fieldbus connector	(general purpose only)										(Note 5)			Z
Aluminium alloy (DIN version)	M20 x 1.5 (CM20)														J
Aluminium alloy (DIN version)	Harting Han 8D connector	(general purpose only)										(Note 5)			K
Aluminium alloy (DIN version)	Fieldbus connector	(general purpose only)										(Note 5)			W
Output/Additional options - 15th characters															
HART digital communication and 4 to 20 mA		No additional options											(Notes 6, 7)		H
HART digital communication and 4 to 20 mA		Options requested by “Additional ordering code”											(Note 6)		1
PROFIBUS PA		No additional options											(Notes 6, 7)		P
PROFIBUS PA		Options requested by “Additional ordering code”											(Note 7)		2
FOUNDATION Fieldbus		No additional options											(Notes 6, 7)		F
FOUNDATION Fieldbus		Options requested by “Additional ordering code”											(Note 7)		3
HART and 4 to 20 mA Safety - certified to IEC 61508		No additional options											(Notes 6, 7)		T
HART and 4 to 20 mA Safety - certified to IEC 61508		Options requested by “Additional ordering code”											(Note 6)		8

ADDITIONAL ORDERING INFORMATION for model 266DHH

Add one or more 2-digit code(s) after the basic ordering information to select all required options

				XX	XX	XX	XX
Drain/vent valve (material and position) (wetted parts)							
AISI 316 L ss	on process axis	(Note 8)	NACE	V1			
AISI 316 L ss	on flange side top	(Note 8)	NACE	V2			
AISI 316 L ss	on flange side bottom	(Note 8)	NACE	V3			
Hastelloy C-276™	on process axis	(Note 9)	NACE	V4			
Hastelloy C-276™	on flange side top	(Note 9)	NACE	V5			
Hastelloy C-276™	on flange side bottom	(Note 9)	NACE	V6			
Monel 400™	on process axis	(Note 10)	NACE	V7			
Monel 400™	on flange side top	(Note 10)	NACE	V8			
Monel 400™	on flange side bottom	(Note 10)	NACE	V9			
Hazardous area certifications							
ATEX Intrinsic Safety II 1 G and II 1/2 G Ex ia IIC T6; II 1 D Ex iaD 20 T 95 °C and II 1/2D Ex iaD 21 T95 °C							E1
ATEX Explosion Proof Group II Category 1/2 G Ex d IIC T6 and Group II Category 1/2 D Ex tD A21 IP67 T85 °C				(Note 11)			E2
ATEX Type „N“ Group II Category 3 G Ex nL IIC T6 and Group II Category 3 D Ex tD A22 IP67 T85 °C							E3
Combined ATEX - Intrinsic Safety, Explosion Proof and Type „N“				(Note 11)			EW
Combined ATEX, FM Approvals (USA) and FM Approvals (Canada)				(Note 11)			EN
FM Approvals (Canada) approval				(Note 11)			E4
FM Approvals (USA) approval				(Note 11)			E6
FM Approvals (USA and Canada) Intrinsic Safety							EA
FM Approvals (USA and Canada) Explosion Proof				(Note 11)			EB
FM Approvals (USA and Canada) Nonincendive							EC
IEC Intrinsic Safety II 1 G and II 1/2 G Ex ia IIC T6; II 1 D Ex iaD 20 T 95 °C and II 1/2D Ex iaD 21 T95 °C;							E8
IEC Explosion Proof Group II Category 1/2 G Ex d IIC T6 and Group II Category 1/2 D Ex tD A21 IP67 T85 °C				(Note 11)			E9
IEC Group II Category 3 G Ex nL IIC T6 and Group II Category 3 D Ex tD A22 IP67 T85 °C							ER
Other hazardous area certifications							
GOST (Russia) EEx ia							W1
GOST (Russia) EEx d				(Note 11)			W2
GOST (Kazakhstan) EEx ia							W3
GOST (Kazakhstan) EEx d				(Note 11)			W4
Inmetro (Brazil) EEx ia							W5
Inmetro (Brazil) EEx d				(Note 11)			W6
Inmetro (Brazil) EEx nL							W7
Integral LCD							
Digital LCD integral display							L1
TTG (Through-The-Glass) digital LCD controlled display							L5
Surge							
Surge/Transient Protector							S2

Model 266DHH Differential flange mounted

ADDITIONAL ORDERING INFORMATION for model 266DHH		XX	XX	XX	XX	XX
Operating manual (up to 2 different selections allowed)						
German	M1					
Italian	M2					
Spanish	M3					
French	M4					
English	M5					
Chinese	M6					
Plates language						
German					T1	
Italian					T2	
Spanish					T3	
French					T4	
Additional tag plate						
Supplemental wired-on stainless steel plate						I1
Laser printing of tag on stainless steel plate						I2
Configuration						
Standard – Pressure = inH2O/ psi at 68 °F; Temperature = deg. F						N2
Standard – Pressure = inH2O/ psi at 39.2 °F; Temperature = deg. F						N3
Standard – Pressure = inH2O/ psi at 20 °C; Temperature = deg. C						N4
Standard – Pressure = inH2O/ psi at 4 °C; Temperature = deg. C						N5
Custom						N6
Certificates (up to 2 different selections allowed)						
Inspection certificate EN 10204–3.1 of calibration (9-point)						C1
Inspection certificate EN 10204–3.1 of the cleanliness stage						C3
Inspection certificate EN 10204–3.1 of helium leakage test of the sensor module						C4
Inspection certificate EN 10204–3.1 of the pressure test						C5
Certificate of compliance with the order EN 10204–2.1 of instrument design						C6
Overfill protection						C9
Printed record of configured data of transmitter						CG
PMI test of wetted parts						CT

ADDITIONAL ORDERING INFORMATION FOR MODEL 266DHH		XX	XX	XX	XX
Approvals					
GOST (Russia) without Ex		Y1			
GOST (Kazakhstan) without Ex		Y2			
GOST (Ukraine) without Ex		Y3			
GOST (Belarus) without Ex		Y4			
DNV approval			YA		
Lloyd approval			YB		
Approval for Custody transfer			YC		
Bureau Veritas approval			YD		
Material traceability					
Certificate of compliance with the order EN 10204–2.1 of process wetted parts					H1
Inspection certificate EN 10204–3.1 of process wetted parts					H3
Test report EN 10204–2.2 of pressure bearing and process wetted parts					H4
Connector					
Fieldbus 7/8 in. (Recommended for FOUNDATION Fieldbus) - (supplied loose without mating female plug)		(Notes 7, 12)			U1
Fieldbus M12x1 (Recommended for PROFIBUS PA) - (supplied loose without mating female plug)		(Notes 7, 12)			U2
Harting Han 8D – straight entry - (supplied loose)		(Notes 6, 12)			U3
Harting Han 8D – angle entry - (supplied loose)		(Notes 6, 12)			U4

- Note 1: Not available with EN mounting flange code M, N, L
Note 2: Not available with ASME mounting flange code A, B, D, E
Note 3: Suitable for oxygen service
Note 4: Not available with diaphragm material/fill fluid code S, H, A, B, L, Q
Note 5: Select type in additional ordering code
Note 6: Not available with Housing code G, Z, W
Note 7: Not available with Housing code E, K
Note 8: Not available with Process flanges/adapters code D, E, G, H
Note 9: Not available with Process flanges/adapters code A, B, G, H
Note 10: Not available with Process flanges/adapters code A, B, D, E
Note 11: Not available with Housing code J, K, W
Note 12: Not available with Housing code A, B, S, T, J

Standard delivery items (can be differently specified by additional ordering code)

- Adapters supplied loose
- Plug on axis of horizontal connection flange
- General purpose (no electrical certification)
- No display, no mounting bracket, no surge protection
- English manual and labels
- Configuration with kPa and deg. C units
- No test, inspection or material traceability certificates

THE SELECTION OF SUITABLE WETTED PARTS AND FILLING FLUID FOR COMPATIBILITY WITH THE PROCESS MEDIA IS A CUSTOMER'S RESPONSIBILITY, IF NOT OTHERWISE NOTIFIED BEFORE MANUFACTURING.

NACE CONFORMITY IS ACCORDING TO RECOMMENDATIONS PER MR0175. AISI 316 AND HASTELLOY C-276 ALSO COMPLY WITH MR0103 IF ALREADY WITH MR0175.

Contact us

ABB Ltd.

Process Automation

Howard Road
St. Neots
Cambridgeshire PE19 8EU
UK

Tel: +44 (0)1480 475321

Fax: +44 (0)1480 217948

ABB Inc.

Process Automation

125 E. County Line Road
Warminster
PA 18974
USA

Tel: +1 215 674 6000

Fax: +1 215 674 7183

ABB Automation Products GmbH

Process Automation

Schillerstr. 72
32425 Minden
Germany

Tel: +49 551 905 534

Fax: +49 551 905 555

ABB S.p.A.

Process Automation

Via Statale 113
22016 Lenno (CO)
Italy

Tel: +39 0344 58111

Fax: +39 0344 56278

www.abb.com

Note

We reserve the right to make technical changes or modify the contents of this document without prior notice. With regard to purchase orders, the agreed particulars shall prevail. ABB does not accept any responsibility whatsoever for potential errors or possible lack of information in this document.

We reserve all rights in this document and in the subject matter and illustrations contained therein. Any reproduction, disclosure to third parties or utilization of its contents - in whole or in parts - is forbidden without prior written consent of ABB.

Copyright© 2010 ABB

All rights reserved

3KXP300009R1001

™ Hastelloy C-276 is a Cabot Corporation trademark

™ Monel is an International Nickel Co. trademark

™ Viton is a Dupont de Nemour trademark

™ Galden is a Montefluos trademark

™ Halocarbon is a Halocarbon Products Co. trademark