

## 2600T Series Pressure Transmitters

Models 266H/N

Models 268H/N

**IndustrialIT**  
enabled

---



## The Company

ABB is an established world force in the design and manufacture of instrumentation for industrial process control, flow measurement, gas and liquid analysis and environmental applications.

As a part of ABB, a world leader in process automation technology, we offer customers application expertise, service and support worldwide.

We are committed to teamwork, high quality manufacturing, advanced technology and unrivalled service and support.

The quality, accuracy and performance of the Company's products result from over 100 years experience, combined with a continuous program of innovative design and development to incorporate the latest technology.

The NAMAS Calibration Laboratory No. 0255(B) is just one of the ten flow calibration plants operated by the Company, and is indicative of ABB dedication to quality and accuracy.

EN ISO 9001: 1994



Cert. No. Q5907

ISO 9001: 2000



Cert. No. 9/90A



Cert. No. 0255

## Use of Instructions



### Warning.

An instruction that draws attention to the risk of injury or death.



### Note.

Clarification of an instruction or additional information.



### Caution.

An instruction that draws attention to the risk of damage to the product, process or surroundings.



### Information.

Further reference for more detailed information or technical details.

Although **Warning** hazards are related to personal injury, and **Caution** hazards are associated with equipment or property damage, it must be understood that operation of damaged equipment could, under certain operational conditions, result in degraded process system performance leading to personal injury or death. Therefore, comply fully with all **Warning** and **Caution** notices.

Information in this manual is intended only to assist our customers in the efficient operation of our equipment. Use of this manual for any other purpose is specifically prohibited and its contents are not to be reproduced in full or part without prior approval of ABB Technical Communications Department.

## Health and Safety

To ensure that our products are safe and without risk to health, the following points must be noted:

1. The relevant sections of these instructions must be read carefully before proceeding.
2. Warning labels on containers and packages must be observed.
3. Installation, operation, maintenance and servicing must only be carried out by suitably trained personnel and in accordance with the information given. Any deviation from these instructions, will transfer the complete liability to the user.
4. Normal safety precautions must be taken to avoid the possibility of an accident occurring when operating in conditions of high pressure and/or temperature.
5. Chemicals must be stored away from heat, protected from temperature extremes and powders kept dry. Normal safe handling procedures must be used.
6. When disposing of chemicals ensure that no two chemicals are mixed.

Safety advice concerning the use of the equipment described in this manual or any relevant hazard data sheets (where applicable) may be obtained from the Company address on the back cover, together with servicing and spares information.

---

## CONTENTS

---

Section	Page
INTRODUCTION .....	3
TRANSPORT, STORAGE, HANDLING AND PRODUCT IDENTIFICATION .....	4
SAFETY PHILOSOPHY, MANAGEMENT OF FUNCTIONAL SAFETY, INFORMATION REQUIREMENTS .....	5
LIFE-CYCLE ACTIVITIES .....	6
FAULT OUTSIDE THE FUNCTIONAL SAFETY .....	8
PRINCIPLE OF OPERATION .....	9
INSTALLATION .....	12
ELECTRICAL CONNECTIONS .....	15
ELECTRICAL REQUIREMENTS .....	17
COMMISSIONING AND CONFIGURATION ISSUES .....	18
CALIBRATION .....	19
PRE-STARTUP ACCEPTANCE TEST, PROOF TESTS .....	21
DISMANTLING AND REASSEMBLY .....	22
SIMPLE FAULT FINDING .....	23
RETURNING FORM .....	24
ADDENDUM FOR "METERS" OPTION OF THE TRANSMITTERS .....	25
ADDENDUM FOR COMETER OR INDICATOR WITH HART PROGRAMMING CAPABILITY AND PROMETER - PROGRAMMABLE INDICATOR .....	26
ADDENDUM FOR PV-SCALING OPERATION .....	31
ADDENDUM FOR "SURGE PROTECTION" OPTION OF THE TRANSMITTERS .....	32
ADDENDUM FOR SELECTABLE OUTPUT FUNCTIONS .....	35
ADDENDUM FOR OUTPUT % RERANGING .....	38
ADDENDUM FOR "EX SAFETY" ASPECTS AND "IP" PROTECTION (EUROPE) .....	39

---

## INTRODUCTION

---

The **2600T** series is a modular range of field mounted, micro-processor based electronic transmitters, using a unique inductive sensing element. The Model 266/268H/N is a pressure transmitter with "single port" process connection; this provides accurate and reliable measurement of gauge and absolute pressure, in the even most difficult and hazardous industrial environments.

Now a Safety pressure Transmitter is included in the 2600T Series, with its analog output signal plus HART digital communication.

The HART digital protocol allows remote re-ranging, calibration and diagnostics, without any interference with the standard 4-20 mA analog output signal.

This operating instructions manual describes the Safety version of the 2600T Series transmitters and specify all information necessary to safely connect the Safety 2600T pressure transmitter in a Safety Instrumented System.

It details also how the signals from the input field device should be interpreted.

Refer to the shortened contents of this manual, here in this page for addressing the section of your interest, and also to the supplementary documentation for additional remarks.

---

## SUPPLEMENTARY DOCUMENTATION

---

Reference information on remote seals and configuration of the transmitter can be found in the following documents:

SS/S26 Remote Seal Specification

SS/268xx Data Sheets

IM / 691HT Hand-Held Communicator

Online HELP SMART VISION Configuration Program

IEC 61508 Functional Safety of e/e/pe Safety-related systems

ISA S84.01 Application of Safety Instrumented Systems for the Process Industries

NE43 Standardization of the signal level for the breakdown information of digital transmitters

Other helpful or general information can be found in the ABB web site, at [www.abb.com](http://www.abb.com)

## TRANSPORT

After final calibration, the instrument is packed in a carton (Type 2 to ANSI/ASME N45.2.2-1978), intended to provide protection from physical damage.

## STORAGE

The instrument does not require any special treatment if stored as despatched and within the specified ambient conditions level (Type 2 to ANSI/ASME N45.2.2-1978). There is no limit to the storage period, although the terms of guarantee remain as agreed with the Company and as given in the order acknowledgement.

## HANDLING

The instrument does not require any special precautions during handling although normal good practice should be observed.

## PRODUCT IDENTIFICATION

The instrument is identified by the data plates shown in Figure 1.

The Nameplate (Ref.A) provides information concerning the code number, maximum working pressure, range and span limits, power supply and output signal. See code/specification sheet for detailed information. This plate also shows the transmitter serial number. **Please refer to this number when making enquiries.**

A dedicated label (Ref. B) is welded as standard to the primary unit, carrying specific details of the transducer (diaphragms material, fill fluid, range limits and identification number).

A Safety Marking plate (Ref. C) is fitted when the transmitter is required to comply with hazardous area regulations, e.g. flameproof or intrinsic safety protection. Additionally Tag plate (ref. D) provides the customer tag number and calibrated range, maximum process working pressure (PS) and temperature (TS).

The instrument may be used as a safety accessory (category IV) as defined by the Pressure Equipment Directive 97/23/EC. In this case, near the CE mark, there is the number of the notified body (1130) that verified the compliance.

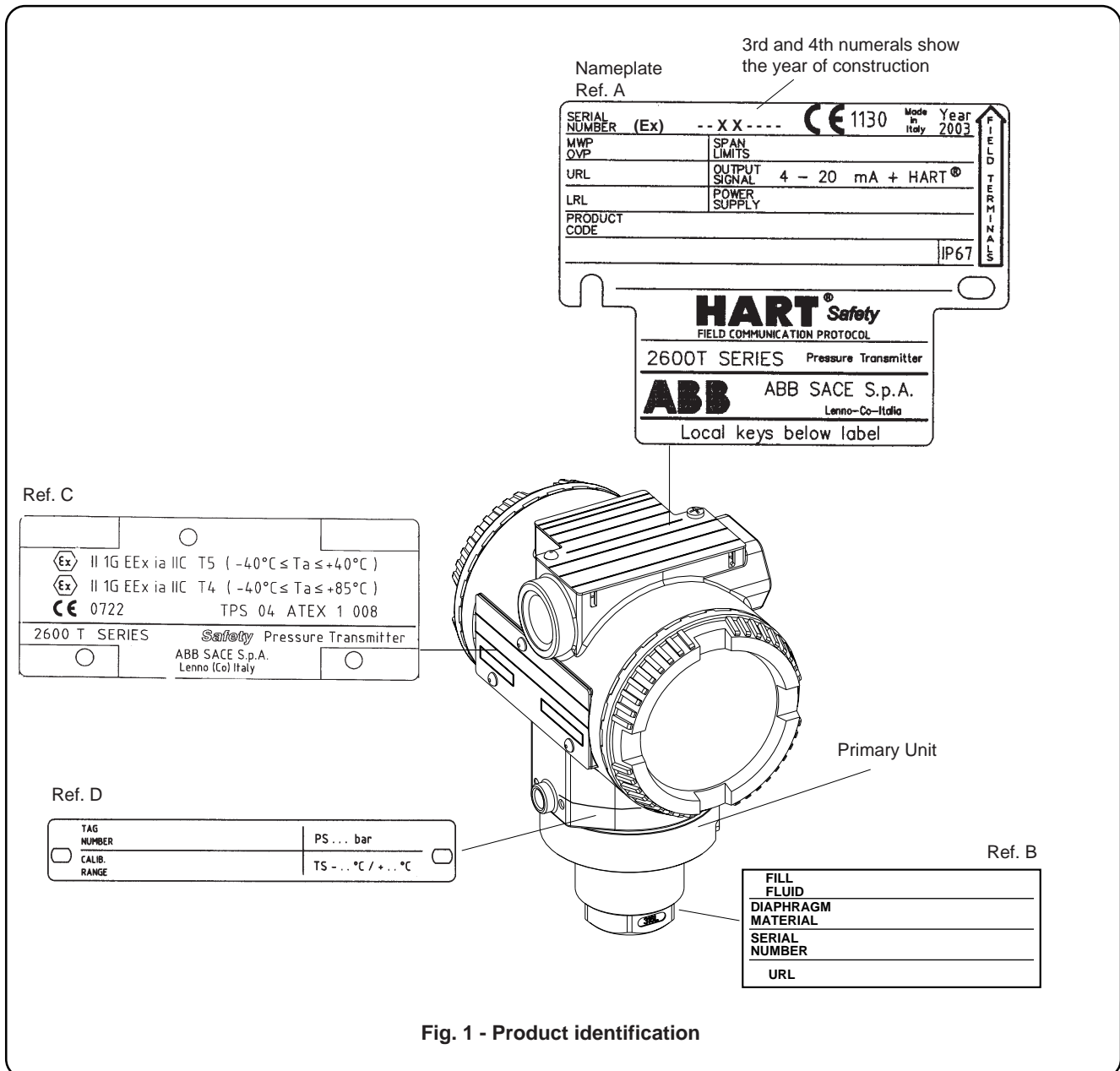

Fig. 1 - Product identification



**Important - The instrument serial number must always be quoted when making enquiries.**

---

## **SAFETY PHILOSOPHY**

---

The Safety 2600T Pressure Transmitters are field devices designed according to the requirements of the standard IEC61508 for the Safety Related Systems. Standard currently used focus on individual parts of all the safe instrumentation used to implement a safety function. The IEC61508 defines requirements related to all the system that normally comprises initiating devices, logic solver and final elements. It also introduces the concept of Safety lifecycle defining the sequence of activities involved in the implementation of the safety instrumented system from conception through decommissioning. For a single component it is not correct to define a SIL level. The term SIL (Safety Integrity Level) refers to the complete safety loop therefore the single device shall be designed in order to be suitable to achieve the desired SIL level in the entire Safety Loop.

### **Application**

The Safety 2600T Pressure Transmitters are intended to be applied for safety relevant application in the process industry. They are suitable to be used in SIL2 applications. Special attention has to be given to the separation of safety and non-safety relevant use.

### **Physical Environment**

The transmitter is designed for use in industrial field environments and must be operated within the specified environmental limits as indicated in the Transmitter Data Sheet.

### **Role and Responsibilities**

All the people, departments and organisations involved in the life-cycle phases which are responsible for carrying out and reviewing the applicable overall, E/E/PES (Electrical/Electronic/Programmable Electronic System) or software safety lifecycle phases of a Safety Instrumented System shall be identified. All those specified as responsible for management of functional safety activities shall be informed of the responsibilities assigned to them. All persons involved in any overall, E/E/PES or software safety lifecycle activity, including management activities, should have the appropriate training, technical knowledge, experience and qualifications relevant to the specific duties they have to perform.

---

## **MANAGEMENT OF FUNCTIONAL SAFETY**

---

For each application the installer of the owner of a safety system must prepare a Safety Planning which must be updated throughout the Safety Life-cycle of the Safety Instrumented System. The requirements for the management of functional safety shall run in parallel with the overall safety lifecycle phases.

### **Safety Planning**

The Safety Planning shall consider:

- policies and strategies for achieving safety;
- safety life-cycle activities to be applied, including names of responsible persons and departments;
- procedures relevant to the various life-cycle phases;
- audits and procedures for follow up.

---

## **INFORMATION REQUIREMENTS**

---

The information shall comprehensively describe the system installation and its use in order that all phases of the overall safety lifecycles, the management of functional safety, verification and the functional safety assessment can be effectively performed.

### **Overall Safety Life-cycle Information**

The overall safety lifecycle shall be used as the basis for claiming conformance to the standard IEC61508. The lifecycle phases consider all the activities related to the Safety Instrumented System (SIS) from the initial concept through design, implementation, operation and maintenance to decommissioning.

The relevant lifecycle phases for the 2600T Safety Pressure Transmitter used in a SIS are listed below:

- Overall scope definition;
- Hazard and risk analysis;
- Overall safety requirements;
- Safety requirement allocation;
- Overall Operation and Maintenance planning;
- Overall Installation and Commissioning planning;
- Overall Installation and Commissioning;
- Overall Safety Validation (SIS Start-up documentation);
- Overall Operation (diagnostic messages documentation);
- Overall maintenance and retrofit (critical system maintenance tracking);
- Overall modification (management of changes and modifications);
- Decommissioning (out of service notification).

### **Application Software Safety life-cycle information**

Not defined.

---

# LIFE-CYCLE ACTIVITIES

---

## **Application Scope**

### **Definition of the Application Target**

The process equipment shall be described in order to define clearly the application target with its hazard potential.

### **Applicable LAWS and Standards**

All applicable general Laws and Standards related to the allowed operations of the equipment, as EU-Directives shall be collected. The plant owner shall produce a Regulatory Requirements List document.

### **Definition of the Application Scope**

The scope for the safety-related application shall be fully described in order to produce the following documentation:

- Safety Integrity Level classification;
- Functional safety requirements of the equipment under control

Necessary steps for the definition of the above listed documents are:

- Detailed investigation about which potential hazards of the process equipment have been reduced by design or an independent layer of protection.
- Checking of the necessary functional requirements required by the applicable laws and Standards.
- Determination of the Safety Integrity Level with a specific risk reduction method.
- Specification of each functional risk reduction by its physical risk, properties to be measured, its safe action to be performed

## **Functional Safety Requirements of the Target Equipment**

### **Safety Functions**

The documents:

- Safety Requirement Specification;
- Piping and Instrument Diagram;

Shall be produced in order to fully define the safety functions of the Safety Instrumented System. Necessary steps for the definition of the above listed documents are:

- Definition of the required Safety Functions.
- List of all the process conditions under which the safe action is required.
- Investigation of the effect of common cause failures.
- Specification of the actions required for the process measurement failures which are not covered by the Safety Functions.
- Identification if the required safe actions are dependent on operating states or are effective under all operating states.
- Transformation of the verbal functional requirements into a graphical form.

### **Process Interface**

The documents:

- Functional Requirement Specification;
- Piping and Instrument Diagram;
- Functional Diagram

Shall be produced in order to fully describe the process interface and connections. Necessary steps for the definition of the above listed documents are:

- Definition of the Process Interface requirements.
- Identification of the instrumentation for every physical risk property (input) and define their fail safe signal.
- Definition of the required amount of instruments and certifications according the SIL requirements
- Identification of the type of actuator and definition of their fail safe position for the required safe action
- Definition of the required redundancy and certification
- Completion of the functional diagram with instrumentation details
- Definition of the necessity of a regulatory body approval;

## **System Safety Requirement Assignment**

### **I/O System Response Time**

The total system response time is determined by the following elements:

- Sensor detection time,
- Logic solver time;
- Actuator response time;

The total system response time must be less than the process safety time. To ensure a safe operation of the system, the scan rate of each section of the logic solver multiplied by the number of channels must be less than the safety time less actuator and sensor response time.

### **I/O System Selection**

The I/O system selection is mainly dictated by the required logic solver time. Appropriate selection procedures and analysis shall be used.

### **System Structure**

System configuration drawings shall be available to describe the equipment and interfaces required for a complete operational system. The system must be fully operational before start-up.

### **Safety Requirement Allocation**

Each safety function, with its associated safety integrity requirement, shall be allocated to the designated safety-related systems taking into account the risk reductions achieved by the other technology safety-related systems and external risk reduction facilities, so the necessary risk reduction for that safety function is achieved. The allocation indicated shall be done in such a way that all safety functions are allocated and the safety integrity requirements are met for each safety function.

### **Programming Environment**

Computer system which provides the necessary software to program, compile, and load an application shall be separated.

### **Safety Routines**

Safety additional requirements may be defined in order to ensure the correct functionality of sequences in the Safety Instrumented System.

### **Safety Templates**

Safety Templates must be followed for particular applications. (e.g. SIL 2 and burner management applications have certified "Templates" that adhere to all the rules spelled out by the applicable regulations).

### **Separation of Safety Functions**

Each safety function shall be separated in a different programming section.

---

## **. . . . LIFE-CYCLE ACTIVITIES**

---

### **Application Software Development**

#### **Programming Environment**

The application software of the Safety 2600T has been developed in ANSI C language using the IAR 1.31B compiler. Emulation and system testing have been performed with the support of Mitsubishi ICE development system.

#### **Program Structure for Safety Applications**

The complete software has been separated in a safety relevant and a non-safety relevant sections. The safety relevant area is constituted by a set of modules and functions which are rigorously separated and checked in their correct execution.

#### **Safety Logic Programming**

A specific document has been developed to define the basic rules for C-Programming in safety related system applications in compliance with what defined by the IEC 61508-3. The software development of the Safety 2600T has been carried out following the restrictions and recommendation contained in the above mentioned documents.

#### **Program Compilation**

Special accuracy have been used in the software development in order to avoid any error and warnings.

#### **Application Software Testing**

A Safety 2600T transmitter functional test report document has been issued after the operational and the safety related program have gone through their initial check. It verifies that the program will perform as desired and specified.

#### **Application Software Safety Validation**

The Safety 2600T Application Software testing has been carried out and audited by TUV PS. A Test Report document approved by TUV states that the system reacted in each test as expected and that the safety related program fulfil the Safety Requirement Specification

### **Installation**

#### **Environmental Requirements**

The Safety 2600T pressure transmitter has been designed to operate in a wide range of environmental conditions typical of industrial field and in hazardous environments. The environmental conditions under which the measuring equipment is designed to operate within its specified accuracy limits and without impairment of its operating characteristics are specified in the "Specification Sheet" document.

#### **Mechanical installation and System completion**

All the necessary operations to correctly installing the device in order to assure operator and plant safety are described in the section "installation" of the present manual.

#### **System Wiring**

The procedures to safely make the electrical connections of the device are described in the section "electrical connections" of the present manual. For installation in hazardous areas, compliance with safety information on the safety marking plate shall be ensured.

### **Commissioning**

#### **Field Instrument Functionality**

All the necessary activities to assure that the process sensor

or final element are operating together and perform the required function are described in the "Electrical connections" and "Calibration" sections of the present document.

#### **Overall System Functionality**

The activities to validate the required safety functionality of the system together with the target equipment according to the Safety Requirement Specification are Pre-Startup Acceptance test section of the present document.

### **Operation**

#### **System Operating Discipline**

A Plant policy guideline document containing the specific plant policy guideline for the daily safe operation has to be produced and periodically reviewed by representatives of the Process Control Service.

#### **Maintenance**

Maintenance is defined as the routine activities which are carried out to detect unrevealed faults.

#### **Preventive and Routine Maintenance**

Preventive and routine maintenance activities are defined in the maintenance section of the present manual.

#### **Function-unit Replacement**

In case of hardware failure corrective actions may be carried out. In case of transmitter replacement all the operations described in "Electrical Connection", "Calibration" and "Pre-Startup Acceptance tests" shall be conducted.

All maintenance activities shall be documented in the system documentation. Possible safety critical failures shall be reported using the Incident Report process.

#### **Function-unit Repair**

The transmitter is constituted of two main units (transducer and electronics). It can be repaired following the information contained in the Dismantling and Reassembly section of the present manual.

Central repair shall maintain a record of detected failures, calculate actual failure rates and compare with the expected failure rate. Extensive failure rates shall be communicated to the supplier.

#### **Modification Request**

Request of modification due to possible safety critical failures and performance deviations shall be reported to the factory. Modifications shall follow the company modification procedures.

#### **Management of Change**

All process changes or SIL category change shall follow the procedures defined in the safety life-cycle of the system and shall be reviewed and validated by the external competent body for a new functional safety assessment.

#### **Management of change Process Components and Roles**

Each process component needs to be defined in details according to the requirements and the relevant documentation. Each process component change shall follow the activities defined in the overall safety life cycle.

#### **Management of change Documentation and Training Requirements**

The Management of Change process shall follow documentation and training requirements defined in the system implementation.

## FAULTS OUTSIDE THE FUNCTIONAL SAFETY

The redundant algorithms and the electronics are designed to detect all the internal hardware faults therefore the transmitter diagnostic is not able to detect faults related to the process and to the installation configuration. In the following table the known weaknesses resulting from the transducer FMEA (Failure Mode and Effect Analysis) are listed.

failure	failure effect	Comments
Assembled material at the pipes of the transmitter, blockage of pipe.	$\Delta p$ -level measurement is wrong	Piping should be periodically inspected and cleaned.
Application outside specified temperature range. Excess of temperature	wrong measurement	The transmitter should operate inside the specified temperature ranges.
Assembled gas at the transmitter, if the transmitter is mounted above the process line	insensitive, wrong measurement	Transmitter should be installed properly as specified in this manual.
Overload pressure, high peak pressure pulses in process lines	wrong measurement after compression stress	The transmitter should operate inside the specified temperature ranges.
Penetration of hydrogen, diaphragm crack in applications with hydrogen process medium.	insensitive measurement, breakdown	Hydrogen service allowed with the application of a special grace on diaphragms or by using gold plated diaphragms.
Thin walled diaphragm, leaky diaphragm in applications with abrasive medium.	wrong measurement, breakdown	Transmitter manual specifies the preventive periodic maintenance.
Thin walled diaphragm, leaky diaphragm in applications with corrosive medium.	wrong measurement, breakdown	Appropriate materials should be selected for corrosive applications.
Higher diaphragm stiffness, crack in application with contamination of metal ions	insensitive measurement	Appropriate materials should be selected for particular applications.
Mechanical damage through cleaning, damage of the coating, corrosion.	faulty or insensitive measurement, breakdown	Transmitter manual specifies correct maintenance procedures.

### Other considerations

The alarm levels of the transmitter (down-scale or up-scale) can be selected by the user. For some faults (e.g. crystal breakdown), the output will latch at 22 mA even if the down scale alarm level is selected.

# PRINCIPLE OF OPERATION

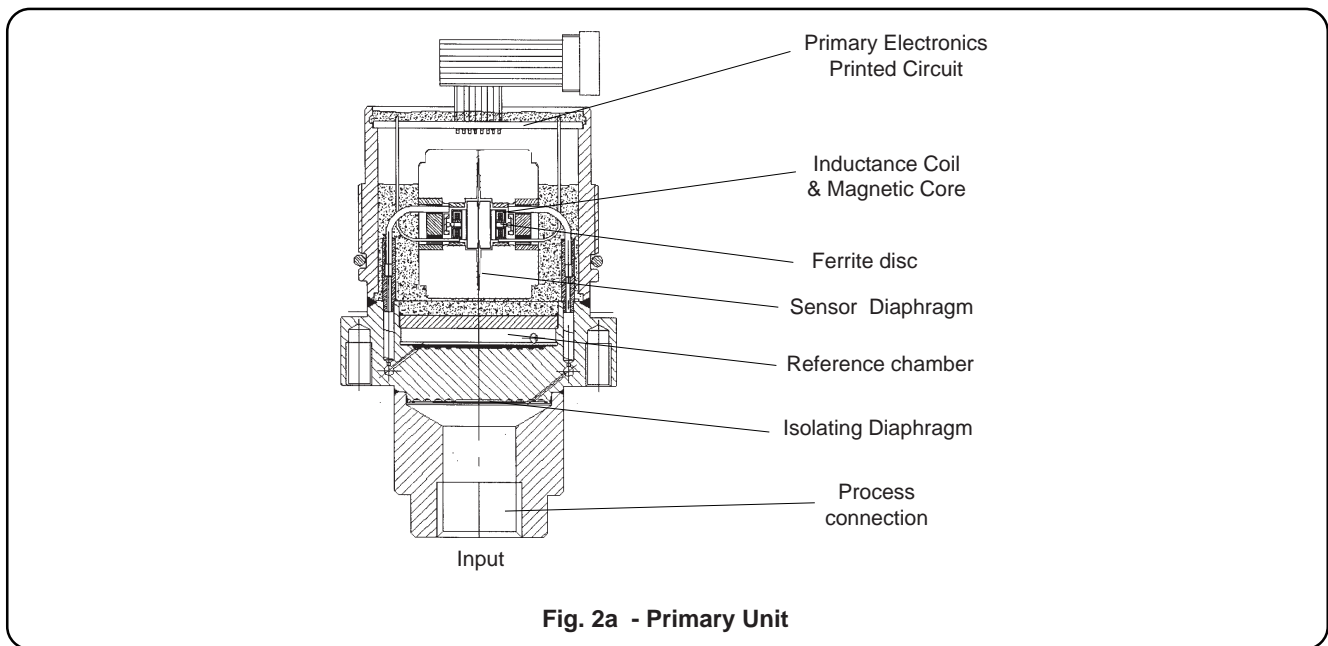

**Fig. 2a - Primary Unit**

The instrument consists of two functional units:

- Primary Unit
- Secondary Unit

The Primary Unit includes the process interface and the sensor, the Secondary Unit includes the electronics, the terminal block and the housing. The two units are mechanically coupled by a threaded joint. All units are based on custom integrated components (Application Specific Integrated Circuit - ASIC). The principle of operation of the Primary Unit is as follows. The process fluid ( liquid, gas or vapour ) exerts pressure on to the measuring diaphragm via flexible, corrosion-resistant isolating diaphragm and the fill fluid (see Fig. 2a). The other side of the measuring diaphragm is either at "atmosphere", for gauge measurement, or at "vacuum", for absolute measurement. As the measuring diaphragm deflects in response to input pressure changes, it simultaneously produces variations in the gap between the magnetic disc and the magnetic core of the coil, which is mounted rigidly on to the primary body. As a result, the inductance of the coil changes.

The inductance values of the coil is compared to that of a reference inductor carried by the primary electronics.

The unit also includes a temperature sensor. The two inductance values and the sensor temperature, are combined in the primary electronics to provide a proprietary standard signal. Consequently the further elaboration, together with temperature signal is equivalent allowing to use the same secondary electronics.

In the manufacturing process the sensor output characteristics are compared with reference pressures and temperatures: the "mapped" parameters are then stored in EEPROM # 1.

The measured values and the sensor parameters are transferred to the Secondary Unit, where a microprocessor computes precise primary output linearisation, compensating for the combined effects of sensor non linearity and temperature changes. In the secondary electronics EEPROM #2 stores specific transmitter information:

- non modifiable data such as the serial number, the UID (Unique Identifier), the manufacturer's name and device type, the hardware and software version of the electronics.
- the modifiable data such as the final trimming and calibration ie., all data that can be changed by the user through the configurator devices.

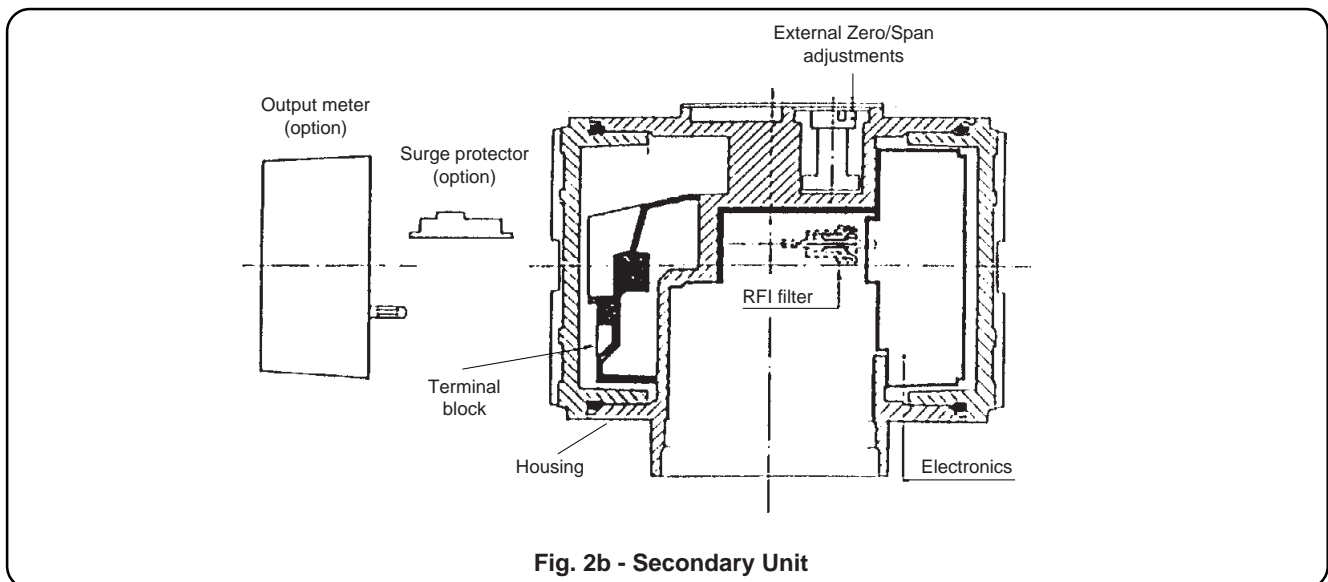

**Fig. 2b - Secondary Unit**

## ... PRINCIPLE OF OPERATION

2600T Safety Transmitter takes advantage of the intrinsic redundancy of the 2600T series differential inductive sensor. The two inductive signals are separately detected in the primary unit by two independent ASICs and separately elaborated internally to the electronics. Calculations follow independent flows and they are compared in the microcontroller in order to validate the output pressure signal. If a difference between the two measurements is detected the analog output is driven to a safety condition. Internal diagnostics algorithms

are implemented to check correctness and validity of all processing variables and the correct working of memories. A supplementary shut down circuitry provides a safe shut down when a fault occurs in the analog section of the electronics. The output stage is also checked by reading back the analog output signal. The feedback loop is obtained by an additional A/D converter put at the end of the output stage, which translates the 4-20 mA signal into a digital form suitable to be compared by the microcontroller.

### HARDWARE DESCRIPTION

#### General hardware description

The electronic hardware structure is described in the following figure.

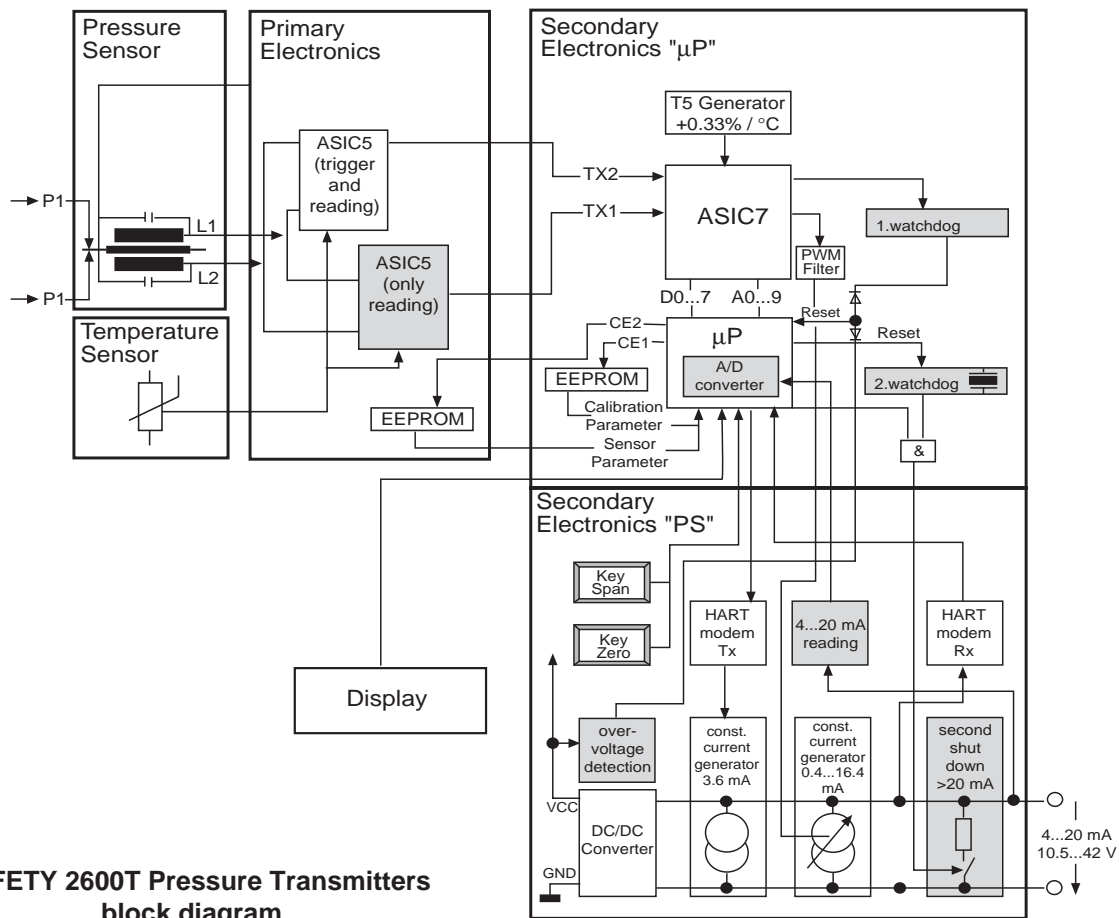

**SAFETY 2600T Pressure Transmitters  
block diagram**

#### Pressure Sensor

The pressure sensor gives the primary input signal to the electronics. The input pressure is converted in a (micro) displacement "d" of a metal diaphragm (measuring diaphragm) whose stiffness determines the URL of the sensor. The diaphragm displacement changes the gap of a magnetic circuit, generating the variation of the inductive pick-up detector constituted of two inductances called L1 and L2. One of the inductance values increases the other decreases. The inductance value is measured by forming an oscillator with an extra capacitor (C1,C2). The oscillation is excited by a pulse and simultaneously measured by two ASIC5 (see the picture above). The fundamental frequency of oscillation relates to the inductance values with the following law:  $(T=2\pi\sqrt{L(C)})$ .

#### Temperature Sensor

The temperature sensor measures the temperature of the pressure sensor. The resulting value is used by the  $\mu P$  for temperature compensation purposes.

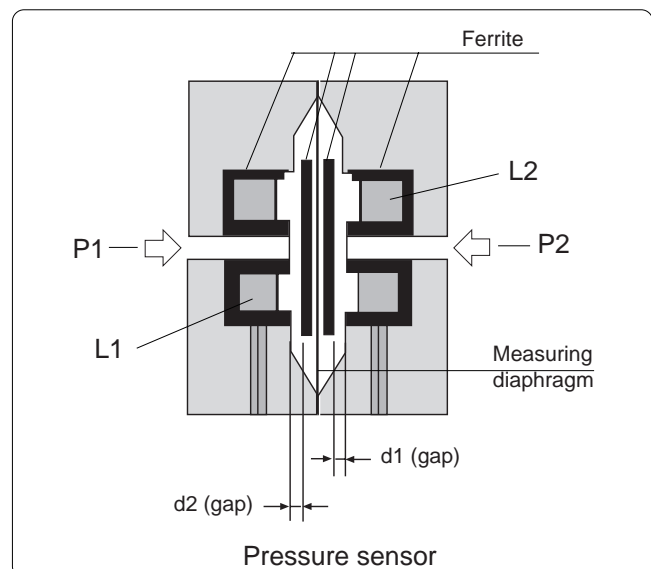

---

## ... PRINCIPLE OF OPERATION

---

### Primary Electronics

Main purpose of this unit is to convert the pressure signal to an electronic pulse-width signal. As help for added accuracy both temperatures and static pressure of the transducer are measured.

### ASIC5

The ASIC5 components contain the basic pulse width converters that convert the input frequency coming from the sensor in two redundant pulse-width signals proportional to the two inductance values L1 and L2. The two independent output time-duration signals from ASIC 5 are applied to the secondary unit through independent lines.

### EEPROM1 Memory

This EEPROM memory is used by the "µP" described later. It contains all the relevant information for the sensor characterization and for the transmitter calibration.

### Secondary Electronics "µP"

This unit uses a µP and an ASIC to convert the basic measured data into correct scaled data. Compensation for temperature and static pressure are also performed. The output data value is converted into a pulse-width signal that is filtered and that activates the 4-20 mA transmitter. The bi-directional, digital communication using the standard "HART" protocol is implemented as part of this unit.

### ASIC7

The main input to ASIC7 are the two independent pressure signals combined on two lines from ASIC5 called TX1 and TX2. The ASIC7 converts in two independent counter sections the pulse widths to two sets of five 24 bits numbers (A/D conversion). The pulse-width information are stored in two different RAM locations and used by the µP to perform all the necessary calculations and consistency checks and to calculate the compensated output with correct scaling. Afterwards the µP writes the calculation results into two 8 bit registers in ASIC7.

### Watchdog1

A watchdog function is implemented in the ASIC7. It interacts with the µP via the Reset block described later. In case of error at first the watchdog resets the µP. After three retries it drives the PWM output in alarm condition (UP/DOWN scale).

### HART Modem

A modem circuit for demodulation is implemented in the ASIC both for receiving and transmitting.

### µP

The µP performs all the calculations and the diagnostic functions. It drives also the supplementary shut down in case of errors in the analog part.

### Reset

There are four reset functions for the µP. "Power On Reset", reset on ASIC7 request as described above and reset on power supply too low or too high.

### PWM Filter

This first order RC filter gives an average value of the pulse width signal from ASIC 7.

### T5 Time Generator

The ASIC7 generates a temperature dependent current (+0.33% / °C) applied to the T5 generation circuit that provides a time duration signal (T5) used to measure the temperature in the secondary electronics.

### Watchdog2

A secondary watchdog is used to monitor the correct working

of the main clock. In case the main clock doesn't work it gives a signal to the supplementary shutdown logic block that provides to force the output in safety condition.

### 4-20 mA reading

The internal microprocessor 8 bit A/D converter provides to convert to a digital value the analog feedback signal from the 4-20 mA output current loop. The obtained value is internally compared with the digital value of the actual output current for diagnostic purposes.

### EEPROM2 Memory

The EEPROM2 memory is used by the µP to store and read configuration data and data concerning calibration of the 4-20 mA generator.

### Secondary Electronics "PS"

This unit contains the 4-20 mA transmitter, the power supply and the basic analog part of the "HART" protocol.

### Constant Current Generator 0-16 mA

This block converts the filtered DC voltage representing the pressure into a 0-16 mA current. The block is trimmed together with the power supply to maintain the stable 4 mA basic current making the total current 4-20 mA.

### Constant Current Generator 3.6 mA

This block generates a stable current basically close to 4 mA. The current generator is also used by the HART protocol in the transmit mode to generate a +/- 400 µA current. Externally this will generate a +/- 100 mV signal across a 250 ohm minimum resistor.

### Local keys

The pressure transmitter has two screws hidden under the nameplate. They can be used for setting ZERO and SPAN values in the unit. The screws turn a magnet, that closes a reed relay, that activates the µP. The ZERO gives the present sensor value as the reference point. The SPAN gives the present sensor value as FULL SCALE value. The screws with the magnet can be removed to prevent unauthorized changes.

### DC/DC converter

The input voltage is stabilized and regulated with a DC-DC converter to provide the circuit power supply.

### HART Rx

The HART modem receiving data are pre-filtered and buffered in this block.

### Over voltage detection

The power supply is continuously monitored. In case the voltage exceeds a fixed dangerous value a reset command to the microprocessor is generated.

### Second shut-down

An additional current generator in parallel to the output regulator allows having an independent shutdown of the output signal. In case of a failure of the microprocessor due to a clock failure or of a failure in the analog output stage the second shut-down is activated forcing in this way the output signal to the up-scale alarm value.

### 4-20 mA reading

A buffer amplifier connected to the microcontroller reads a voltage in the analog output stage proportional to the PWM filtered voltage. It constitutes a feedback signal of the output current.

### Display

Optional. Not Safety relevant.

# INSTALLATION

**WARNING** - In order to ensure operator safety and plant safety it is essential that installation is carried out by suitably trained personnel according to the technical data provided in the Data Sheet for the relevant model included in the supplementary documentation, in particular in the "Operative limits" section.

The transmitter may be mounted on a 2-inch pipe (fig. 4, 5a, 5b, 5c, 6a and 6b) by means of the proper mounting bracket. The transmitter may also be directly, supported by the piping connection.

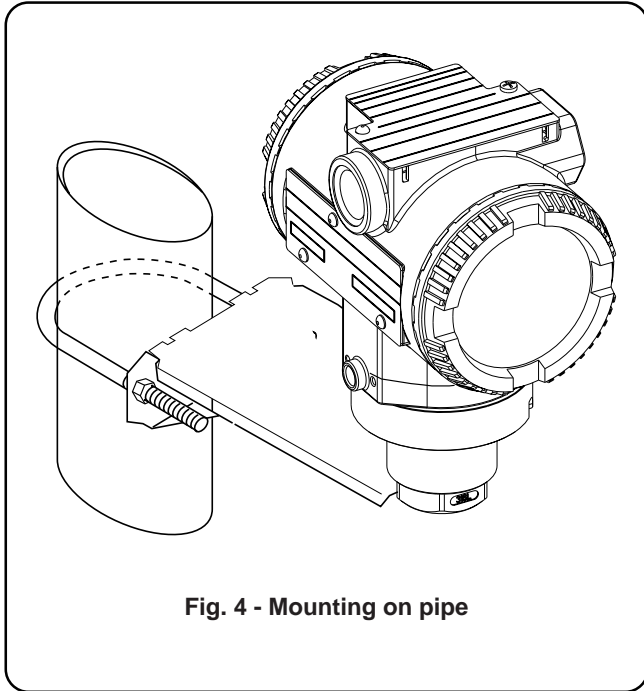

Fig. 4 - Mounting on pipe

**WARNING** - For installation in Hazardous Areas, i.e. areas with dangerous concentrations of e.g. gases or dusts that may explode if ignited, the installation must be carried out in accordance with relative standards either EN 60079-14 or IEC 79-14 and/or with local authority regulations, for the relevant type of protection adopted. Together with safety information here and after enclosed see also the Addendum for "Ex Safety" aspects which is part of this instruction manual.

**WARNING:** The transmitter when installed in accordance with this instruction manual will not be subjected to mechanical stresses.

**WARNING:** the transmitter should not be installed where it may be subjected to mechanical and thermal stresses or where it may be attached by existing or foreseeable aggressive substances. ABB cannot guarantee that a construction material is suited to a particular process fluid under all possible process conditions. See also the paragraph on "Operative limits".

**CAUTION** - Proper location of the transmitter with respect to the process pipe will depend upon the service for which the instrument is used. Care should be exercised to identify correct process connections.

The secondary unit of the transmitter may be rotated through 360° approx. with respect to the primary unit without degrading performance or damaging the internal wiring. Do not force the primary unit to rotate; use the 2 mm Allen key supplied to unlock and lock the tang grub screw (see Fig. 7). This feature, obtained by unscrewing (one turn is sufficient) the Allen screw, is particularly useful for reaching optimum access to the electrical connections and visibility of the output indicator.

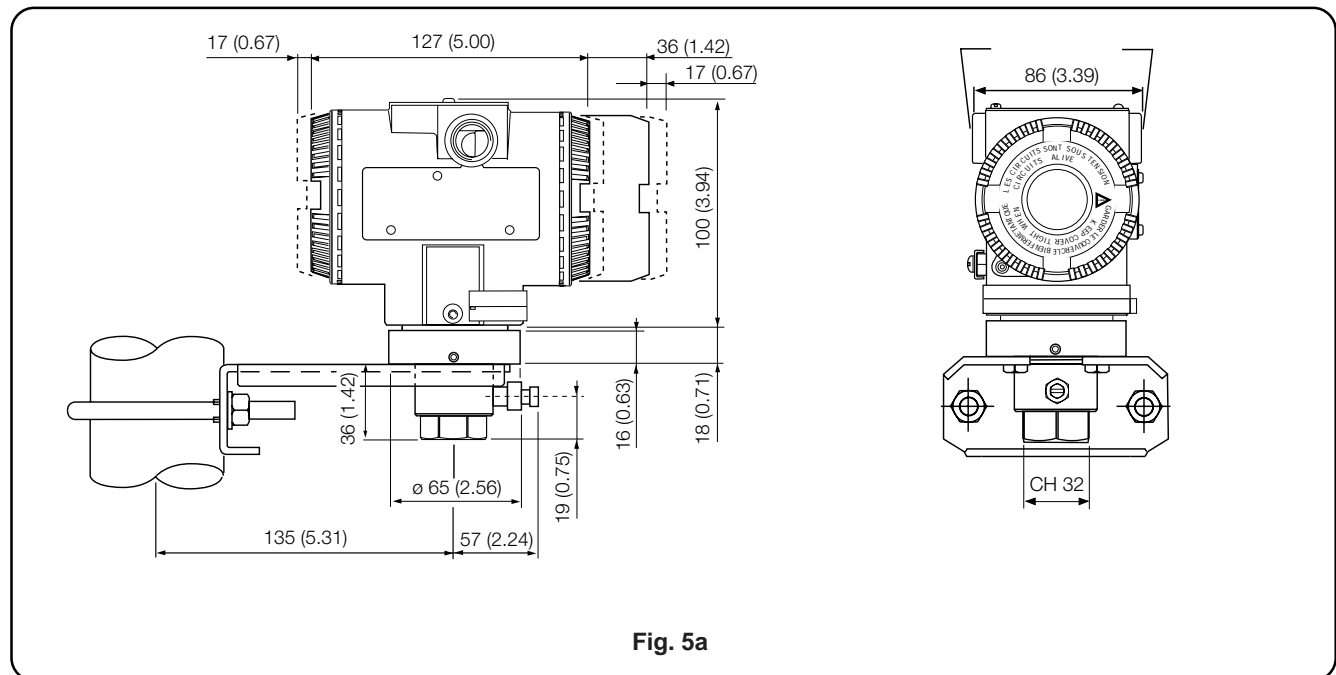
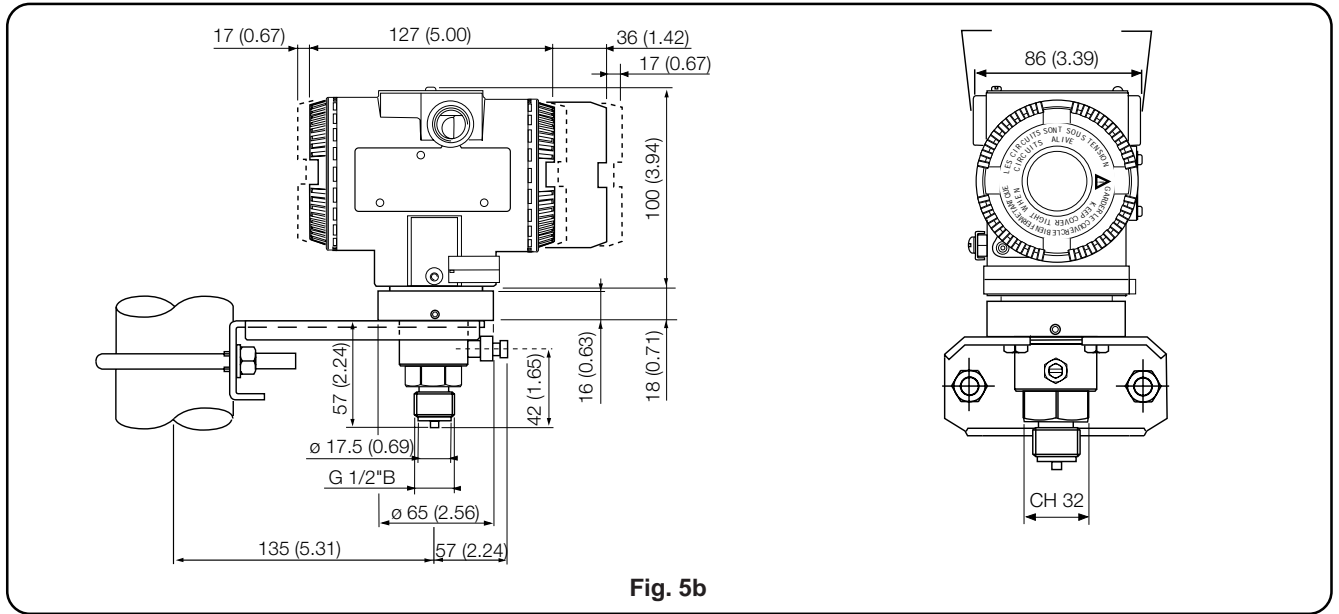

Fig. 5a

1/2in - 14 NPT female connection

Note: dimensions are expressed in mm. (Between parenthesis the same dimensions expressed in inches).

... INSTALLATION



DIN-EN837-1 G 1/2in B connection

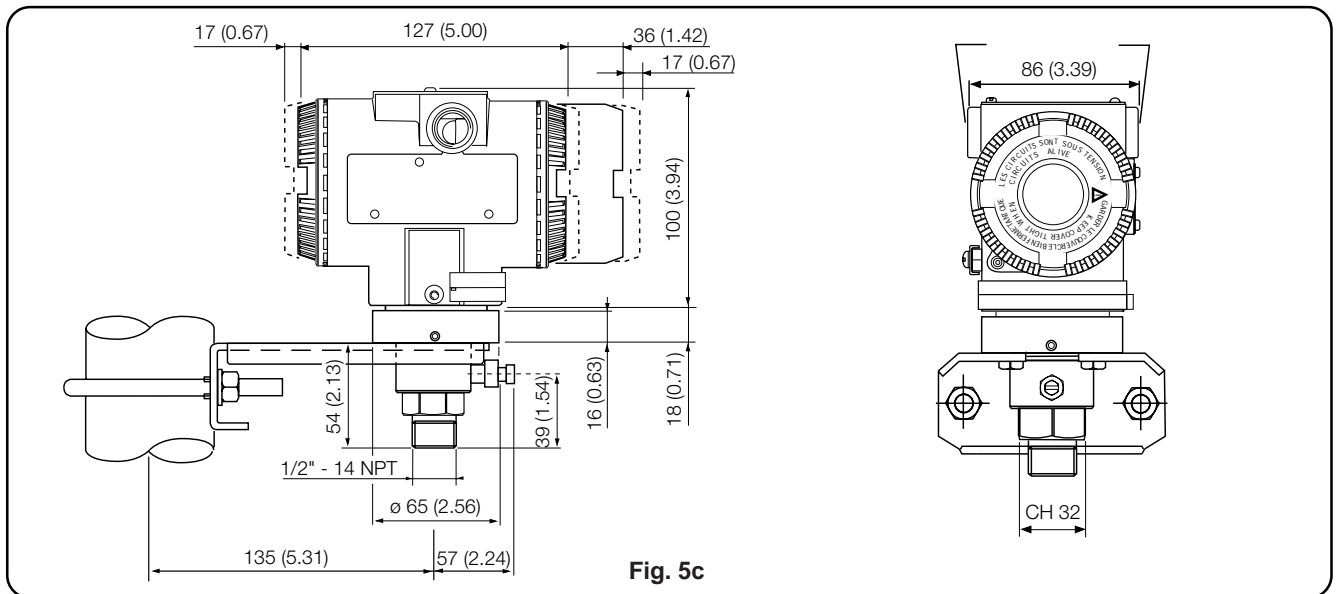

1/2 in - 14 NPT male connection

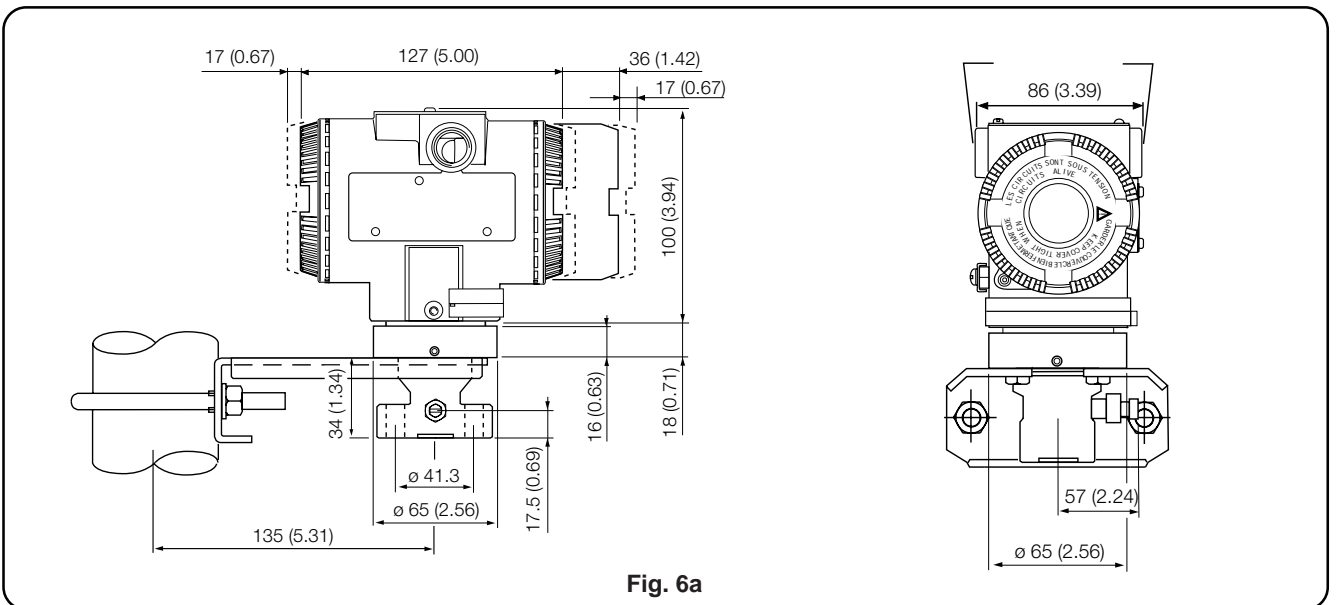

Adapter straight (180°) entry connection (7/16in - 20 UNF drilling)

... INSTALLATION

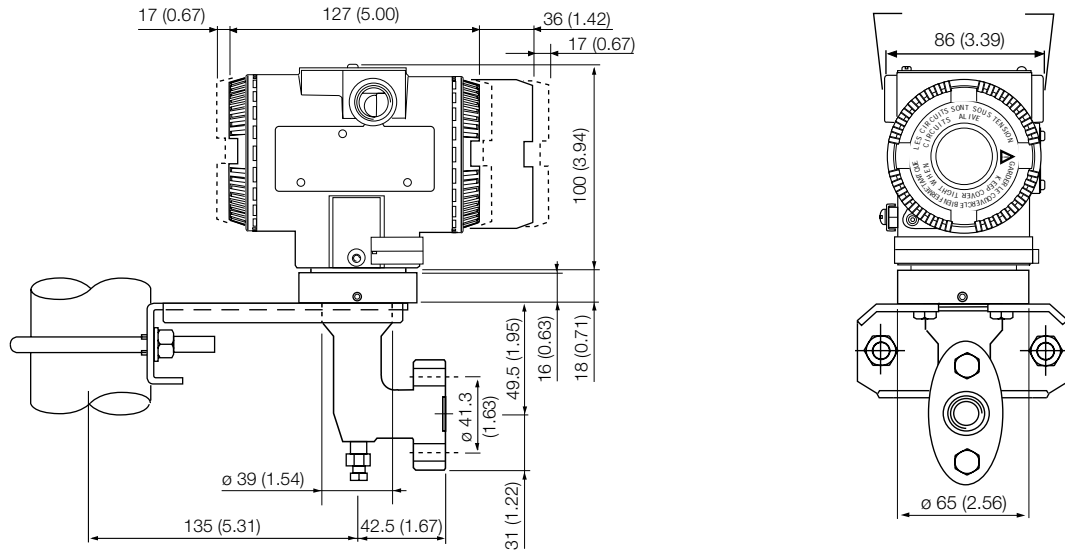

Fig. 6b

Adapter angle (90°) entry connection (7/16in – 20 UNF drilling)

# ELECTRICAL CONNECTIONS

**WARNING** - For installation in Hazardous Areas, i.e. areas with danger of fire and/or explosion, prior to making electrical connections, ensure compliance with safety information on the Safety Marking plate. Failure to comply with this warning can result in fire or explosion.

Signal terminals are located in a separate compartment of the secondary unit housing. The housing incorporates two connection ports for cable glands or conduit fittings. They are protected with a temporary plastic plug for transit purpose which should be replaced with a suitable permanent plug in the unused port. Connections can be made by removing the cover (indicated in Fig. 7); first screw down the locking screw located below the cover, using a 3 mm Allen Key.

**WARNING** - For Hazardous Areas installations, the connection of cables and conduits to the transmitter shall be made in accordance with the requirements of the relevant type of protection. Cables and cable-glands must be in accordance with the type of protection. Unused openings for connection shall be closed with blanking elements suitable for the relevant type of protection. With the exception of intrinsically safe transmitters, the means provided for this shall be such that the blanking element can be removed only with the aid of tools. The blanking elements must be certified for the type of protection. See standards either EN 60079-14 or IEC 79-14. The transmitter connections must also guarantee the degree of protection of the transmitter enclosure, e.g. IPxx according to EN 60529 standard (or IEC529). See also the Addendum for "IP" protection (and Ex Safety) which is part of this instruction manual.

The signal cable should be connected to the terminals marked respectively (+) and (-). If an internal output meter - either with analog or digital indication - is installed, it should be removed in order to make the connection, simply by pulling it out from its socket. After the connections have been made, reinstall the output meter. Refer to the **Meters Option** addendum for details.

The power to the transmitter is supplied over the signal wiring and no additional wiring is required. The signal wiring does not need to be shielded but the use of a twisted pair is highly

recommended. The cable shield should be grounded in one side only, to avoid dangerous earth paths.

**WARNING** - For Hazardous Areas installations, when the ambient temperature is higher than 70°C, the cable used for the connections must be suitable for 5°C above the ambient temperature.

Normal practice is to ground in the control room side, in which case the field side of the screen should be adequately protected to avoid contact with metallic objects. Signal wiring may be ungrounded (floating) or grounded at any place in the signal loop, but for intrinsically safe installations the wiring and grounding must follow the specific rules for this technique. The transmitter case may be grounded or ungrounded: a ground connection is provided internally (in the terminal compartment) and externally.

Do not run the signal wiring in close proximity to power cable or high power equipment; use dedicated conduits or trays for signal wiring.

**CAUTION** - Do not connect the powered signal wiring to the mA signal testing terminals as this could damage the by-pass diode.

After the connections have been completed check the integrity of the cover O-ring, screw down the cover and secure it by unscrewing the safety screw.

**CAUTION** - Unless absolutely necessary, avoid the removal on site of the protective cover which gives access to the electronic circuitry. Although the electronics are fully tropicalized they should not be subjected to humidity for long periods.

**WARNING** - For Hazardous Location installations, at least eight (8) threads on each cover must be engaged in order for the transmitter to meet (FLAME PROOF - explosion-proof) requirements.

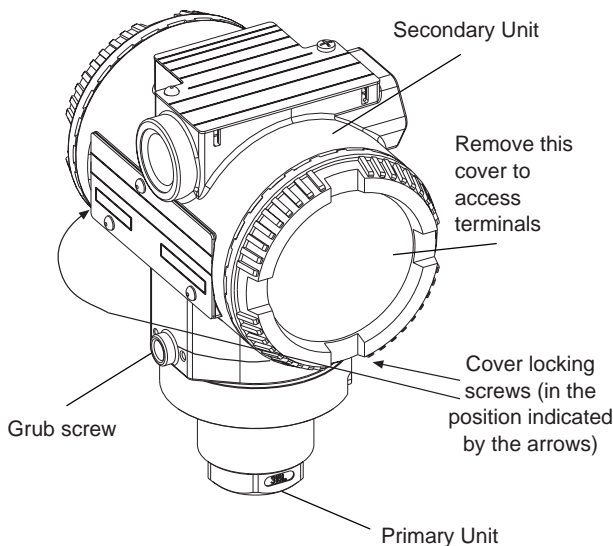

**Fig. 7 - Location of the locking screws and terminals**

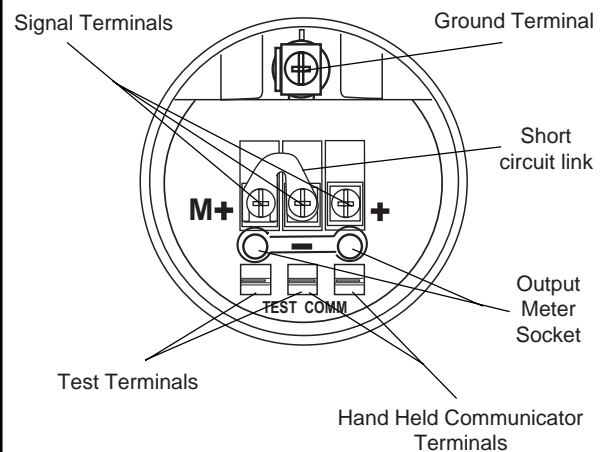

**Fig. 8a - Terminals arrangements**



**WARNING : DO NOT ATTEMPT TO CONNECT AN AMPEROMETER BETWEEN A "TEST" TERMINAL AND A "COMM" TERMINAL. THE RESULT TO THE POWER SUPPLY IS A SHORT WHICH WILL BLOW FUSES AND POSSIBLY DAMAGE YOUR EQUIPMENT, ALSO CAUSING TO INTERRUPT FUNCTION OF OTHER DEVICES POWERED FROM SAME SUPPLY.**



**NOTE:** If the use of the Hand Held Communicator is foreseen, a resistance of 250 ohms minimum **must** be included in the current loop, between the power supply and the connection point of the Hand Held Terminal, for communication purpose.

Here below is given an explanation regarding the possible connection of the terminal block to the power supply and a representation of the connection in case of remote indicator presence (See fig. 8b and 8c).

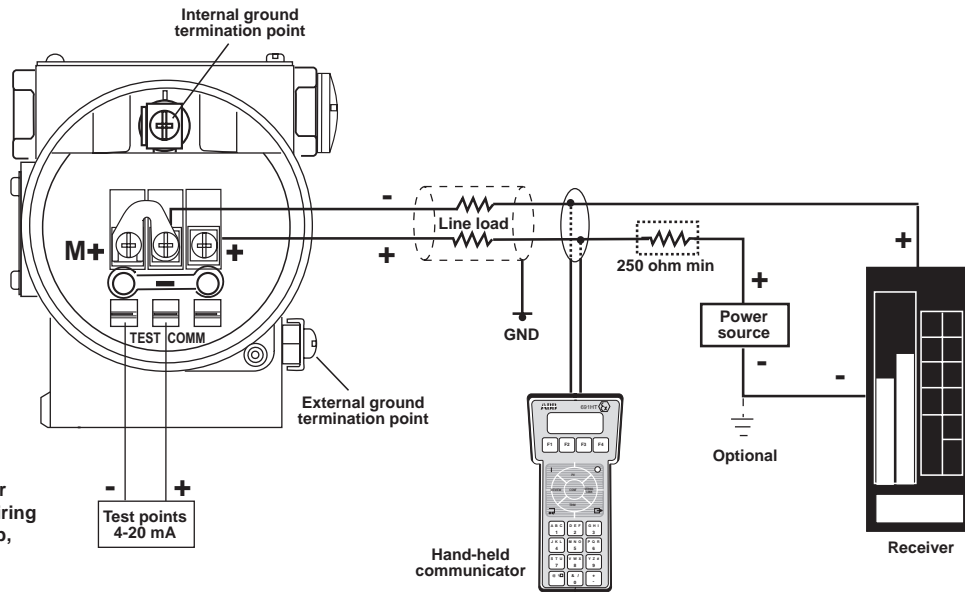

Model 691HT Communicator may be connected at any wiring termination point in the loop, providing the minimum resistance is 250 ohm. If this is less than 250 ohm, additional resistance should be added to allow communications.

Fig. 8b - Electrical connections

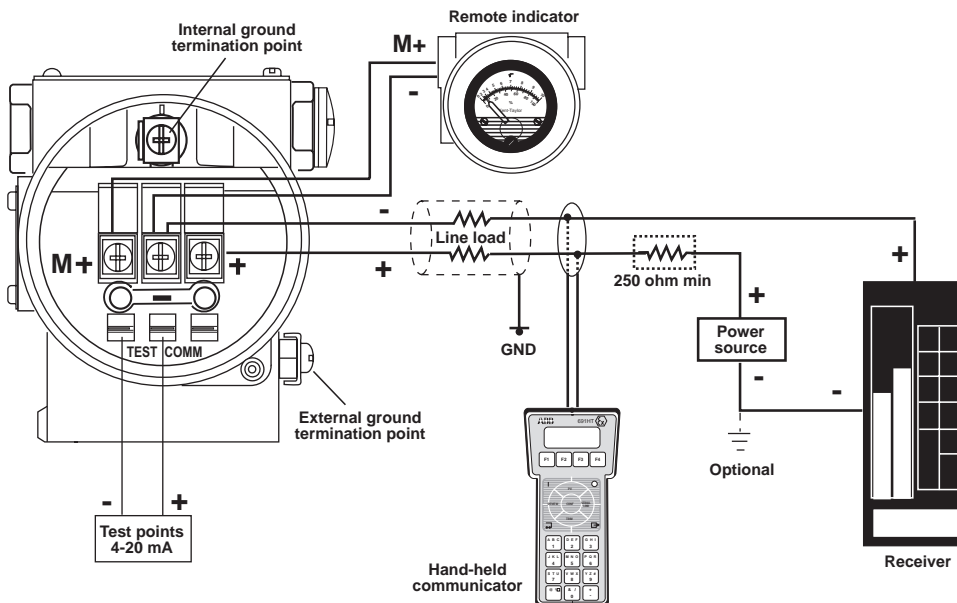

Fig. 8c - Electrical connections with remote indicator

# ELECTRICAL REQUIREMENTS

The transmitter operates on a minimum voltage of 10.5 Vdc to a maximum of 42 Vdc and is protected against polarity inversion.



**Note** - The transmitter operates from 10.5 to 42 Vdc with no load (additional load allows operation over 42 Vdc). For EEx ia and intrinsically safe approval power supply must not exceed 30 Vdc. In some countries the maximum power supply voltage is limited to a lower value.

Installing optional devices the minimum voltage increases to:

- 10.5 Vdc with no option
- 10.7 Vdc with output analog indicator
- 12.5 Vdc with LCD ProMeter
- 12.3 Vdc with surge protection
- 13.3 Vdc with LCD CoMeter
- 15.3 Vdc with no link on output indicator plug

The total loop resistance is indicated in the expression below.

$$R \text{ (k}\Omega\text{)} = \frac{\text{Supply voltage} - \text{min. operating voltage (Vdc)}}{22.5}$$

The total loop resistance is the sum of the resistance of all elements of the loop, including wiring, conditioning resistor, safety barriers and additional indicators (excluding the equivalent resistance of the transmitter).

Where a configuration device (HART), such as the Hand Held Communicator or a Modem is likely to be used, a resistance of 250 ohm minimum should be present between the power supply and the point of insertion of these devices, to allow communication.

Several types of safety barriers, either passive or active, can be satisfactorily used in conjunction with the Smart 2600T transmitters. Nevertheless, in case of use of active barriers, check with the supplier if the model is suitable for use with smart transmitters allowing the connection of the configuration devices in the "safe" or non-hazardous area.

## TRANSMITTER OUTPUT SIGNAL

The 2600T Safety transmitter provides both the analog 4-20 mA and the digital HART communication. HART signals do not affect safety during trading operations. HART writings are permitted only in maintenance (out of safety) condition.

### Analog Signal

Two-wire 4 to 20 mA dc, user-selectable for linear or square root output; power of 3/2 or 5/2, 5th order or two 2nd order switching point selectable programmable polynomial output can be also selected for version with HART communication.

### HART Signal

Digital process variable (% , mA or engineering units) superimposed on the 4 to 20 mA signal, with protocol based on Bell 202 FSK standard.

### Output current limits (compliant to NE 43 NAMUR regulation)

Overload condition:

- Lower limit 3.8 mA dc
- Upper limit : 20.5 mA dc

### Transmitter failure mode (compliant to NE 43 NAMUR regulation)

The output signal can be user-selected to a value of 3.7 or 22 mA on gross transmitter failure condition, detected by self-diagnostics.



**WARNING** - The transmitter may be used as a safety accessory (as defined by the Pressure Equipment Directive 97/23/EC) i.e. as part of a shutdown system. In this case it is recommended to select the correct fail safe mode for the 4-20 mA signal (as per Namur NE43 recommendation). See also the instructions relevant to fail safe selection (Up/Down scale mode) in the addendum to the instruction manual on "Use of hardware links on the secondary electronics" .

## RANGE AND SPAN CONSIDERATION

The Smart 600T EN Transmitter Specification Sheets provide all information concerning the Range and Span limits in relation to the model and the sensor code.

The terminology currently used to define the various parameters is as follows:

**URL** : Upper Range Limit of a specific sensor. The highest value of the measured value that the transmitter can be adjusted to measure.

**LRL** : Lower Range Limit of a specific sensor. The lowest value of the measured value that the transmitter can be adjusted to measure.

**URV** : Upper Range Value. The highest value of the measured value to which the transmitter is calibrated.

**LRV** : Lower Range Value. The lowest value of the measured value to which the transmitter is calibrated.

**SPAN** : The algebraic difference between the Upper and Lower Range Values. The minimum span is the minimum value that can be used without degradation of the specified performance.

**TURN DOWN RATIO** : is the ratio between the maximum span and the calibrated span.

The transmitter can be calibrated with any range between the LRL and the URL with the following limitations:

$$\begin{aligned} \text{LRL} &\leq \text{LRV} \leq (\text{URL} - \text{CAL SPAN}) \\ \text{CAL SPAN} &\geq \text{MIN SPAN} \\ \text{URV} &\leq \text{URL} \end{aligned}$$

# COMMISSIONING AND CONFIGURATION ISSUES

The 600T Safety transmitters contain inside its non-volatile memories a number of parameters. Some of them, factory defined, are typical of the sensor and are not user-modifiable, the other are configuration parameters and can be modified by the user.

During the normal operation status, with the transmitter in safety conditions, all remote and local configuration shall be

disabled. The Safety 2600T pressure transmitter is protected against undesirable configuration changes by a dedicated hardware link placed on the secondary electronics board which is identified as Write Protect Mode Link (see fig. 9).

The following figure described the maintenance-operating philosophy:

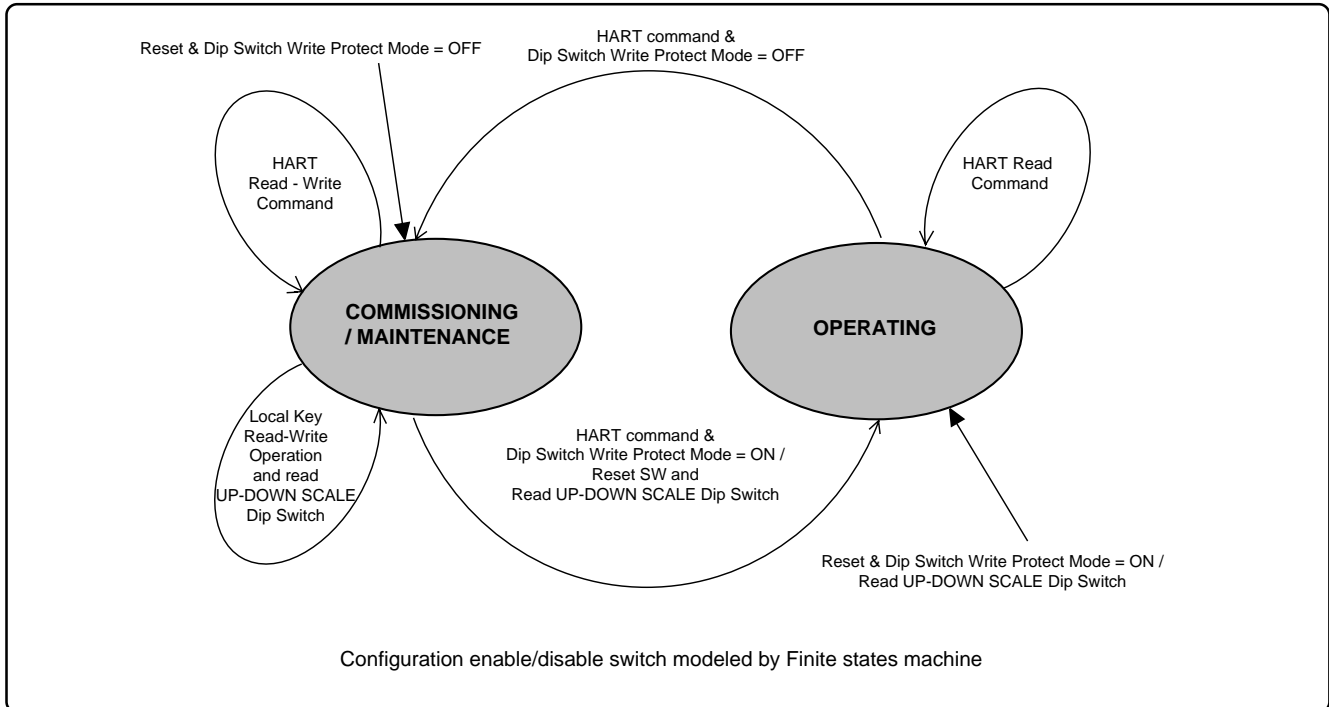

The transmitter is considered in safety condition (normal operating mode) when the switch is in Write Protect (off). In that condition only reading commands are enabled. The special procedure which shall be performed to put the transmitter in operating mode is described in the following section.

### Operating mode enabling and disabling

Operating mode can be enabled/disabled depending on Switch 5 (Write) position at power on condition. The switch is located on the secondary electronics unit under the housing cover. To ensure safety operations of the device a specific HART command shall be performed in order to enable the condition changes.

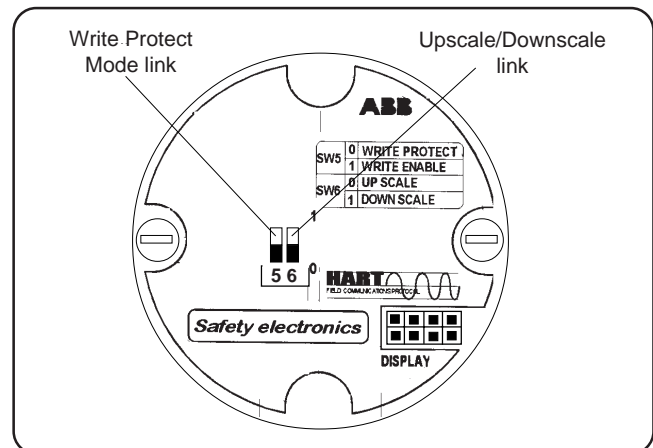

(Switch 5) Write Protect Mode link position at Start-up (power on)	Transmitter status	Operations required to pass to the opposite condition
ON	Maintenance	<ol style="list-style-type: none"> <li>1. Switch in OFF position</li> <li>2. HART Command ("Change transmitter status to operating") or Power OFF/Power ON</li> </ol>
OFF	Operating	<ol style="list-style-type: none"> <li>1. Switch in ON position</li> <li>2. HART Command ("Change transmitter status to maintenance") or Power OFF/Power ON</li> </ol>

Table 1



**WARNING** - After any configuration operation, the transmitter must be put in operating condition as described in Table 1. During this change a software reset is performed and the transmitter is not working for few seconds.

## CALIBRATION

Unlike conventional electronic transmitters, the use of a microprocessor and the presence of serial communications between the transmitter and the configuration device, allows the use of several different approaches in calibration and servicing. Different methods can be used to calibrate the Safety transmitter:

- i) using the zero and span calibration screws in the transmitter secondary unit.
- ii) using the Hand Held Communicator.
- iii) using the Personal Computer Configuration Software Package.

This chapter describes the first method; the others are described next or in the relevant Instruction Manuals of configuration tools. If the calibration screws are not fitted calibration must be done by method ii) or iii).

In the Safety 2600T Series it is also possible to apply a scaling to the reading of the transmitter.

The operation is called PV-scaling and is used to align the "zero" of the process with the "zero" reading of the transmitter. See the description in the Addendum for PV scaling operation.



**Note:** Unless otherwise specified the instrument is factory calibrated at maximum span with the LRV set to true zero. Instruments adjusted and tagged for a specific range will not require recalibration. **Rezeroing of the transmitter may be required in order to compensate for zero shift arising from the installation.**

### Preliminary operation

Before commencing calibration ensure that:

- i) the required span, the upper and lower range value (URV & LRV) are within the span and range limits (URL & LRL) indicated on the nameplate (please refer to "Range and Span" consideration on the previous page).
- ii) the transmitter is properly powered and the electrical connections correctly made.
- iii) the Write Protect Mode link, located on the electronics module is in position ON (write allowed). Access to the link is gained by unscrewing the secondary unit housing cover at the opposite end to the terminal cover (See Fig. 9).
- iv) the Upscale/Downscale link is positioned to the required function: ON for Downscale OFF for Upscale (see Fig. 9).
- v) make the electrical connections, as indicated in Fig. 10. Connect a precision milliammeter as shown and **remove the short circuit link**.

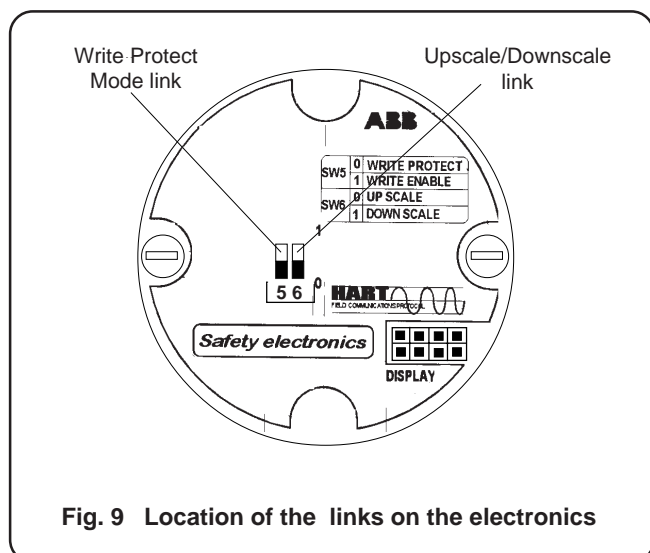

Fig. 9 Location of the links on the electronics

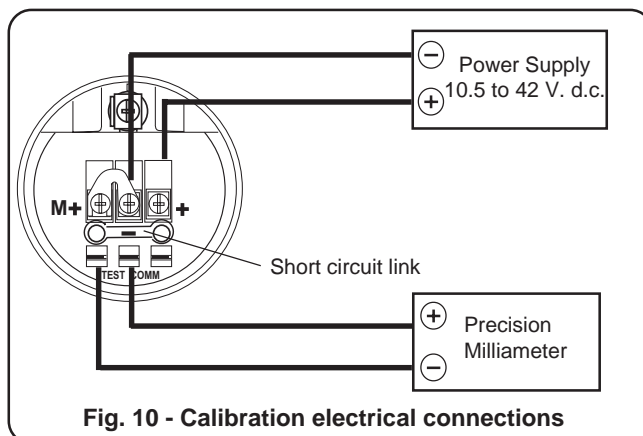

Fig. 10 - Calibration electrical connections

Set up an appropriate test rig in accordance with the required calibration. Figure 11 shows a complete test rig that can be selectively used to suit the calibration.

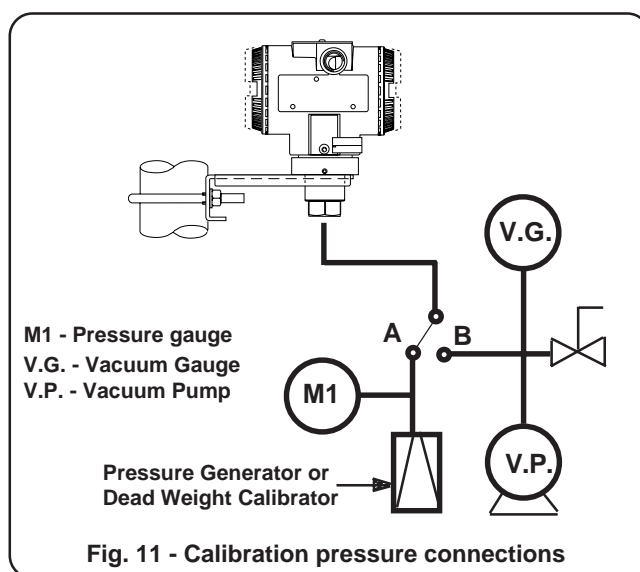

Fig. 11 - Calibration pressure connections

Note that calibration accuracy is strictly related to the accuracy of the test equipment: the use of a dead weight tester is highly recommended.

The zero and span calibration screws are located behind the Nameplate. To gain access slacken the nameplate screw and rotate 90°; proceed in the reverse mode when the calibration procedure has been completed. Fig. 12 shows the calibration screws: they provide two large plastic heads that can rotate 90° in the direction indicated by the arrows, with spring-return to normal. The calibration screws can be removed after the calibration, to avoid improper use by inserting a screwdriver blade below the plastic flange and pulling out.

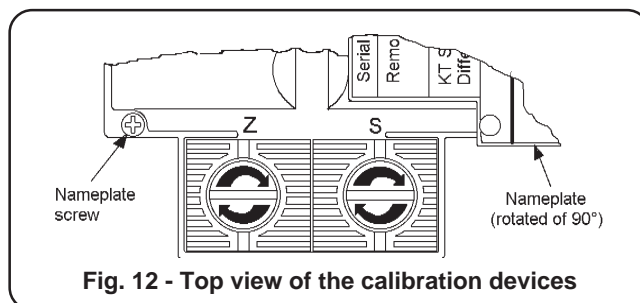

Fig. 12 - Top view of the calibration devices

The calibration screws can be of type "Push buttons" with exactly the same functionality; keep it pressed for at least two seconds.

---

## ... CALIBRATION

---

### Zero and span - true zero procedure

#### Gauge pressure

- Set the A-B switch into "A" position
- Switch on the power supply.
- With no pressure applied to the transmitters, the value read on the digital milliammeter should be 4 mA ; if it is not turn the zero screw for at least 1 second. After this operation the reading should move to 4 mA; if no change occurs repeat the operation.
- Apply a pressure equal to the upper range value (URV) and allow time for the pressure to stabilize.
- Turn the span screw for at least 1 second: after this operation the reading on digital milliammeter should be 20 mA and the calibration procedure is complete. If no change occurs either the calibration procedure was not correctly performed or the span exceeds the limit; correct and repeat the operation.

#### Absolute pressure

- Set the A-B switch into "B" position
- Switch on the power supply.
- Operate the vacuum pump connected to the transmitter and draw the maximum possible vacuum obtainable. The value read on the digital milliammeter should be 4 mA ; if it is not turn the zero screw for at least 1 second. After this operation the reading should move to 4 mA; if no change occurs repeat the operation.
- If the value of the calibration span (URV) is less than atmospheric pressure gently open the vent valve so increasing the pressure to the Upper Range Value. If the calibration span (URV) is greater than the atmospheric pressure then set the A-B switch to "A" position and generate a pressure corresponding to the URV. Allow time for the pressure to stabilize.
- Turn the span screw for at least 1 second: after this operation the reading on digital milliammeter should be 20 mA and the calibration procedure is complete. If no change occurs the calibration procedure was not correctly performed or the span exceeds the limit; correct and repeat the operation.

### Zero suppression procedure

#### Gauge pressure

Two different methods (a) or (b) can be used :

- After completion of the zero and span procedure above, apply a pressure equal to the pressure to be suppressed. Allow time for pressure stabilization and then turn the zero screw for at least 1 second. After this operation the digital milliammeter reading should be 4mA and the Upper Range Value automatically moved to a value equal to the sum of the pressure to be suppressed and the previous calibrated span.
- Use the zero and span procedure above but apply pressures equal to the Lower Range Value (LRV) and then to Upper Range Value (URV), and turning, for at least 1 second, the zero and span screws respectively.

### Absolute pressure

Use the zero and span procedure above but apply to the process connection absolute pressures equal to the Lower Range Value (LRV) and then to the Upper Range Value (URV), turning, for at least 1 second, the zero and span screws respectively.

### Zero elevation procedure

This procedure applies to the gauge pressure transmitter, only. The zero can be elevated up to a full vacuum. Apply pressures equal to the LRV (this value is therefore between the zero gauge pressure and the full vacuum) and then equal to the upper range value (URV) and correspondingly turn the zero and span screws respectively.



**Note** - If during the calibration procedure the readings on the digital milliammeter are outside its inherent accuracy, output trimming of the transmitter may be requested. This operation can only be performed using the Hand Held Terminal Communicator or the Personal Computer Configurator. If this equipment is not available the transmitter should be returned to a Service Center for recalibration.

In some cases, especially for tank level measurement, the calibration can also be obtained automatically by the indication of the actual output percentage, without any calculation for LRV and URV. The operation is called Output % Reranging and can be performed using a HART configuration tool (see the ADDENDUM on Output % Reranging).



**WARNING.** In order to ensure the correct operation of the transmitter, after the calibration procedure the device must be put in "Operating Condition" as described in Table 1, in the section Commissioning and Configuration issues.

## PRE-STARTUP ACCEPTANCE TEST

After the installation of the device in order to validate the required safety functionality of the system together with the target equipment according to the Safety Requirement Specification a Pre-Startup Acceptance test shall be performed as following:

1. Put the Write Protect Mode switch in operating position
  2. Power-on the transmitter: the transmitter performs automatically a self-test that consists in the operations below:
    - Switch-on of the Secondary output
    - Test of the analog output stage and of the feedback A/D converter
- In case the first condition wouldn't happen, the transmitter shall be considered failed and not possible to use. In case the second test would fail the transmitter will drive the output to the selected alarm status. In this case a correction action consists in the re-calibration of the A/D converter. After the correction action the pre-startup test shall be repeated.
3. Put the Write Protect Mode switch in Write Enable condition.
  4. Perform the Hart Command "Change Transmitter status to Maintenance"
  5. Perform the Hart Command "Clock monitor test". The transmitter simulates a clock failure and put the output to Up-scale by the supplementary output stage. In case this condition wouldn't happen, the transmitter shall be considered failed and not possible to use.
  6. Power-off the transmitter
  7. Put the Operating/maintenance switch in operating condition
  8. Power-on the transmitter.

A pre-startup acceptance test report shall be produced to record the test results.

## PROOF TESTS

Safe undetected faults could occur during the operation of the transmitters. These failures do not affect the transmitter operations. **To maintain the claimed Safety Integrity Level (SIL 2) a proof test procedure is requested every 1 year.** The proof tests consists in the following operations:

1. Put the Write Protect Mode switch in Write Enable condition.
2. Perform the Hart Command "Change Transmitter status to Maintenance"
3. Perform the Hart Command "Clock monitor test". The transmitter must go to up-scale setting the secondary output stage. To recover from the alarm status a power-off, power-on operation is required.
4. Power-off the transmitter
5. Put the Write Protect Mode switch in Write Disable condition.
6. Power-on the transmitter. The transmitter must go first to up-scale setting the secondary output stage, then finally the output must provide the actual pressure value.

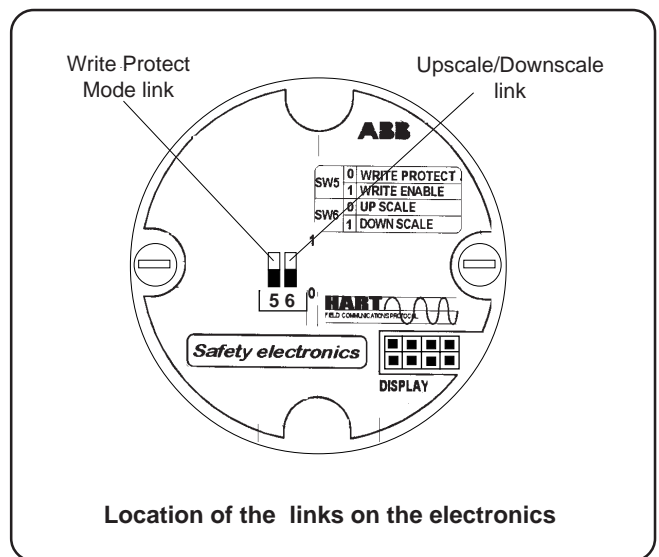

## DISMANTLING AND REASSEMBLY



**WARNING** - Process fluids and/or pressure retained in the transmitter primary unit can cause severe injury and death or damage to the equipment. It is the user responsibility to make sure that no pressure is applied before removing the instrument from service or when draining or venting.

### Dangerous fluids.

In case of toxic or otherwise dangerous process fluid, take any precautions as recommended in the relevant Material Safety Data Sheet.



**CAUTION** - Dismantling and reassembly should not be carried out on site because of the risk of damage to components and printed circuits as a result of adverse environmental conditions such as humidity, dust, etc. The dismantling and reassembly procedures given below should be carried out in the listed order to avoid instrument damage.

### Required tools

- 2 mm Allen key
- 3 mm Allen key
- Small Phillips screwdriver
- Small flat-bladed screwdriver
- 13 mm spanner
- 13 mm torque wrench - (Range > 17 Nm - 12.6 foot lbs)

### Dismantling

- a) Screw down completely the cover locking screw, electronics side, using the 3 mm Allen key
- b) Unscrew and remove the covers
- c) Unscrew the two fixing screws and remove the secondary electronic assembly
- d) Unplug the sensor cable
- e) Remove the tang grub screw using the 2 mm Allen key
- f) Unscrew the housing taking care not to damage the sensor cable or the connector.

### Reassembly



**WARNING** - Assembling flanges with incorrect fixing bolts and nuts and improper "O rings" can cause fracture or overstressing of bolts and release of pressurized process material. Use only official spare parts (\*) included in the supplementary documentation, follow the reassembly procedure herebelow described and do not exceed the specified torque limits. **DO NOT REMOVE** the "O ring" fitted in the sensor neck: it provides the housing a degree of protection.

- a) Insert the sensor cable in its recess at the bottom of the housing.
- b) Screw the housing down completely until the nesting of housing/sensor assy is reached, then unscrew by one complete turn maximum. Rotate the topwork in the desired position and lock it with the tang grub screw previously removed.
- c) Plug the sensor cable to the secondary electronics. Fix the electronic circuit by its screws.
- d) Refit the covers and tighten securely.



**WARNING - For Hazardous Location installations, at least eight (8) threads on the cover must be engaged in order to meet the flameproof (explosion-proof) requirements.**

- e) Unscrew the cover locking screw to secure the covers. This is **mandatory** to meet "**Flameproof requirements**" for **Hazardous Areas** installation.



### PRESSURE TEST WARNING

Once reassembled the process flanges and the transducer, a pressure test is required. At this purpose, apply a hydrostatic pressure of the maximum overrange pressure rating to both process connections simultaneously. Wait for one minute, then verify that no leakages occurred, otherwise repeat the assembly procedure and the pressure test.

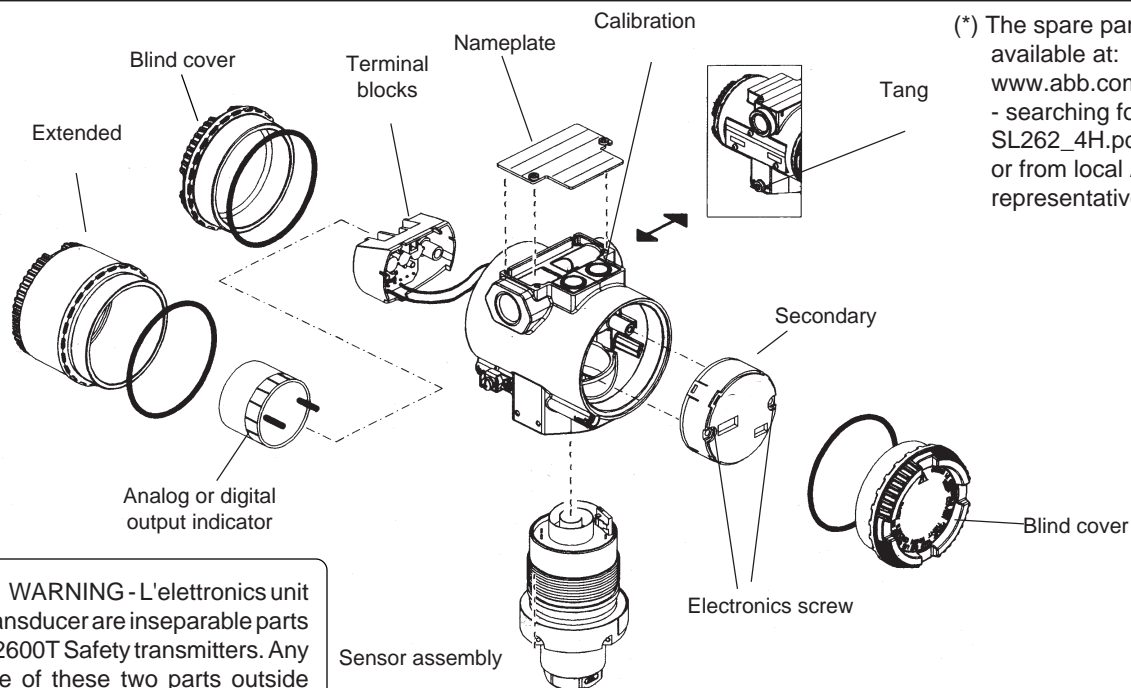

(\*) The spare parts list is available at:  
[www.abb.com](http://www.abb.com)  
 - searching for:  
 SL262\_4H.pdf  
 or from local ABB representatives.



**WARNING** - L'electronics unit and transducer are inseparable parts of the 2600T Safety transmitters. Any replace of these two parts outside the factory will result of a less of the claimed SIL.

Transmitter Sectional View

# SIMPLE FAULT FINDING (HART)

This part is applicable only for a quick fault finding in the case that the Hand Held Terminal or the P.C. Configurator Package are not available.

If the transmitter does not appear to be working satisfactory, carry out the following fault finding checks before contacting your nearest Service Centre.

If the instrument is to be returned for repair, ensure that it is adequately packed using the original polystyrene box or high density chip foam: **the trouble sheet/returning form should be sent with the instrument, filled in all its parts.** If the transmitter needs to be dismantled follow the procedures of the previous section.



**WARNING :** If the transmitter forms part of a control loop, the plant must be placed under local manual control while the instrument is examined or taken out of service. Take all precautions to avoid damages caused by pressure or dangerous fluids release.

## Equipment needed

Voltmeter , milliammeter (0 to 100 mA d.c.), solvent contact cleaner.

### High, Low or Irregular Output

Start (power off)

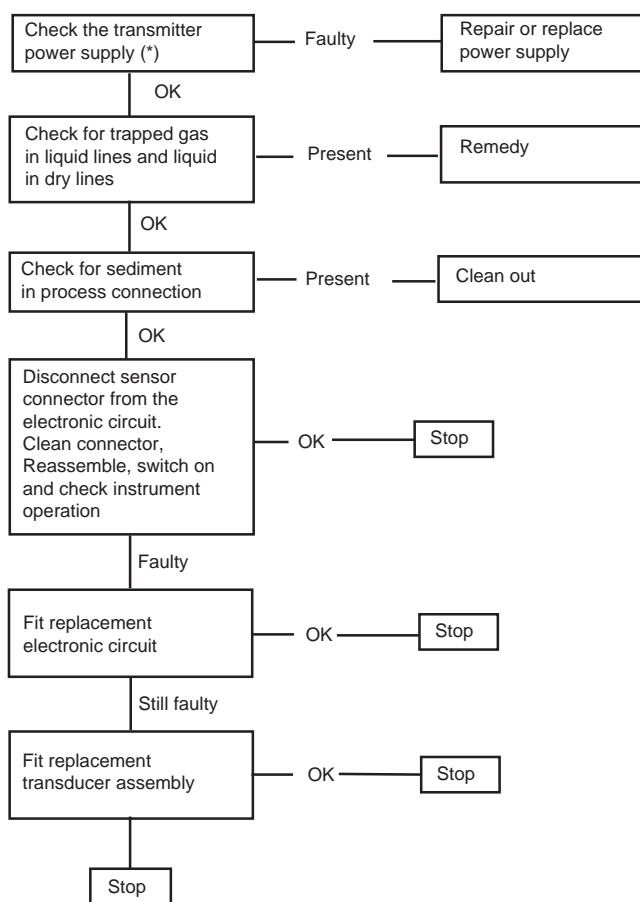

### No output

Start (power off)

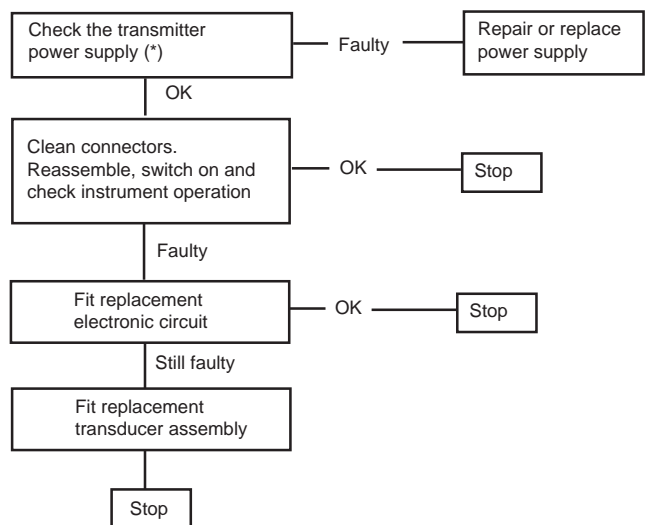

**WARNING -** If the transmitter needs to be repaired, the faulty unit/assembly must be replaced by an equivalent unit/assembly.

(\*) If the source of the problem is suspected to be the power supply, check it by disconnecting the wires from the transmitter and testing the volts available at the wires.



**TROUBLE SHEET**

WARRANTY REPAIR  REPAIR ORDER

Rejection or discrepancy reports

Copy attached  Not available

● IDENTIFICATION

Customer

Purchase order No.

Plant

Name of person to contact

Instrument tag No.

Model

Serial No.

● OPERATING CONDITIONS

Specify location, environmental conditions, type of service and approximate number of operating hours or date of installation if known.

[Empty text box for operating conditions]

● REASON FOR RETURN

[Empty text box for reason for return]

● DANGEROUS FLUIDS

In case of toxic or otherwise dangerous process fluid, please attach the relevant Material Safety Data Sheet.

Trouble found during : Installation  Commissioning  Maintenance   
At start up  On service

Shipping information for the return of the equipment

Material returned for factory repair, should be sent to the nearest ABB Service Center, transportation charges prepaid by the Purchaser.

Please enclose this sheet duly completed to cover letter and packing list

Date

Signature

Originator

# ADDENDUM FOR "METERS" OPTION OF THE TRANSMITTERS

## GENERAL DESCRIPTION

This option provides three different indications (meters) inside the transmitter housing. The "output meters" can be mounted on the terminal block (field terminals) side; one is of "analog" type, the second is of "digital" type (LCD, ProMeter) and the third is the CoMeter. They are operated by the output signal of the transmitter. The meters can be rotated to exactly match the mounting position of the transmitter. The above mentioned CoMeter (abbreviation of Communication Meter) can be used both as a display and as a configuration tool for the Safety 2600T.

## ANALOG OUTPUT METER

The analog output meter provides a 90° scale indication. It has either a 0 to 100 linear scale or a 0 to 10 square root scale.

## ANALOG OUTPUT METER CALIBRATION

The calibration of the analog type meter only involves zeroing. Fig. 1 shows the analog output meter and the location of the zero adjustment.

The calibration is quite simple using one of the following methods:

- with the loop unpowered adjust the zero screw to read exactly the **true zero** mark on the scale (Fig. 1).
- with the transmitter transmitting 4 mA adjust the zero screw to read exactly the **live zero** of the scale.

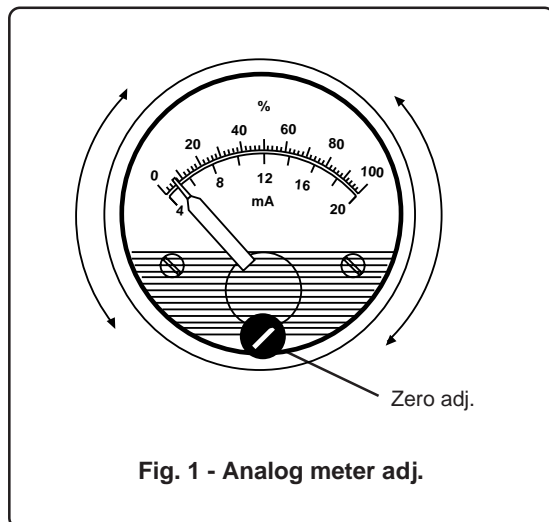

Fig. 1 - Analog meter adj.

## METER INSTALLATION OR REPLACEMENT

**WARNING** - If the transmitter is not certified as Intrinsic Safety type, DO NOT REMOVE ANY COVER in areas classified as "HAZARDOUS LOCATIONS: CAN RESULTS IN HAZARD OF FIRE AND EXPLOSION". Contact your Safety Dpt. in order to establish correct installation procedure.

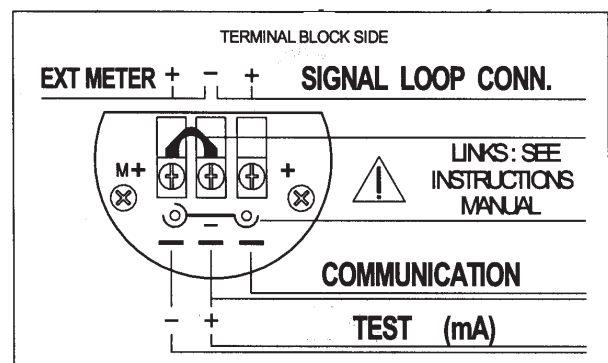

Fig. 2 - Cover Internal label

To install (or to replace) the meter, use the following procedure:

- 1) If the transmitter is part of a control loop, put the loop in manual.
- 2) Remove the cover on the terminal block side; inside of which is affixed the label shown in Fig. 2.
- 3) Remove the link shown on the label by pushing down at its left extremity and then its right. Alternatively it can be removed on the left side only in preparation for a further refit.
- 4) Plug the meter into the socket. The digital indication meter can rotate, for easy viewing, in 15° steps, 90° degree clockwise and 255° counterclockwise. Further rotation causes damage to the meter stops or to the "banana" connections and should be avoided. Note that considerable effort must be applied for 15° rotation. The analog output meter can also rotate for easy viewing.
- 5) Check that the cover O-ring gasket is properly in place, screw on the extended windowed cover and tighten properly.

To remove the meter simply pull it out from the socket and fit a replacement following the above procedure.

**CAUTION** - If the meter is removed, ensure that it is replaced immediately by another one or with the proper link provided. **This operation is important for I.S. loop operation.**

# ADDENDUM FOR COMETER OR INDICATOR WITH HART PROGRAMMING CAPABILITY AND PROMETER - PROGRAMMABLE INDICATOR

The name **CoMeter** is an acronym for **COMMUNICATING METER**. The name **ProMeter** stands for **PROGRAMMABLE METER**.





It can be connected, plug & play, into the standard terminal block of the 2600T Series Pressure Transmitter.

It is capable to provide both reading and configuration operations, when used in connection with the analog-only version, the ProMeter is only indicator. The LCD display has three lines; the first one is used for 5 numeric characters, up to 99999, plus a minus (-) sign on the left and a star (\*) sign, up on the right, to indicate HART communication is in progress; the second line is a 10 segments bargraph used to show the output, from 0% to 100% in 10% steps;

the third line is used for seven alphanumeric characters to display units or messages.

In addition to the display the plastic membrane has 4 push buttons used for programming and for menus navigation.

And more precisely, they are:

- top left position: **ESCAPE** key 
- top right position: **ENTER** key 
- bottom left position: **NEXT** key 
- bottom right position: **PREVIOUS** key 

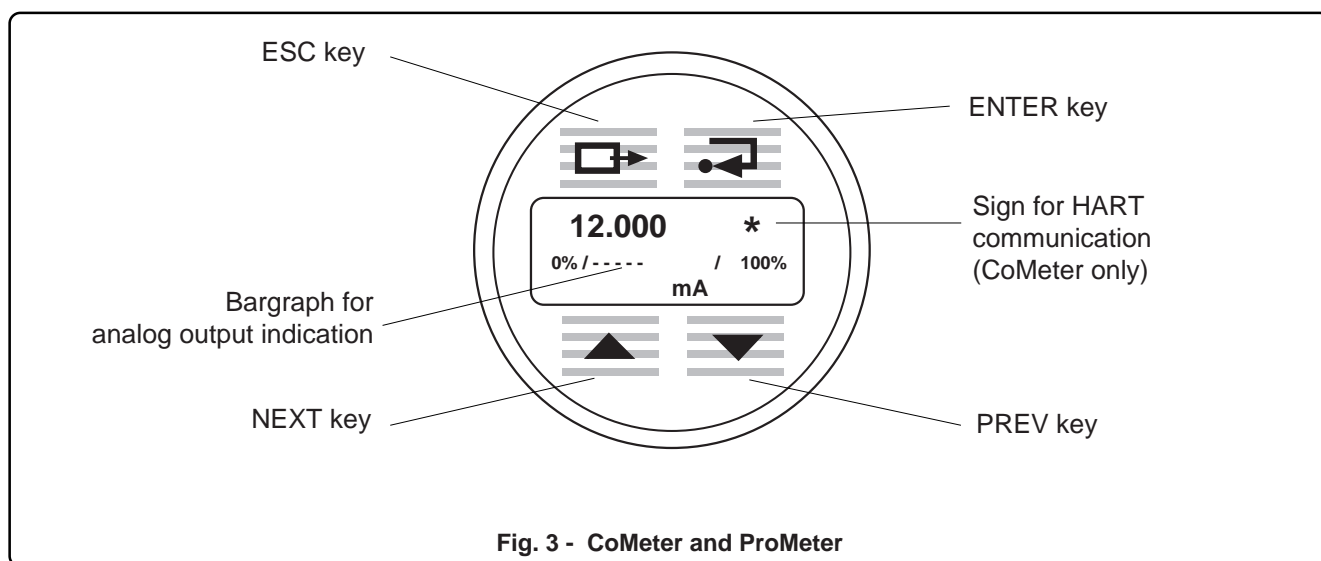

The normal operating condition for CoMeter and ProMeter is to display the analog output signal of the transmitter, expressed in milliAmpere (this is the default setting), or in percentage or in engineering unit, with all the units available as for the HART Communication Protocol.

In addition to the indicator functionality, the CoMeter can be used as a configuration tool, where both the CoMeter itself and the transmitter can be configured. ProMeter is programmable only. In the CoMeter, in fact, two are the main menu : **ConF METER** and **ConF XMTR**.

## ACCESS TO CONFIGURATION

To enter these menù in both indicators, the keys **PREV** and **NEXT** must be pressed simultaneously for 3 seconds, then the user can switch between the XMTR and the METER configuration using the NEXT and the PREV key.

In the ProMeter entry is directly in Manual Configuration, as shown in the next page.

**\* NOTE:** when the Configuration action is finished, remember to press the **ESC** key to return to display the previous selected value.

## ConF METER - METER CONFIGURATION

### PASSWORD

The access to the configuration menus can be protected by a 5 digits numeric password.

It is under the ConF METER menu that the password can be defined and enabled.

See figure 4 for the access to the **"ConF PASSWORD"** menu. Once you have entered the "ConF PASSWORD" menu the cursor is blinking on the most significant digit.

Press **ENTER**, if you want to change the digits, initially set to zero (0).

Use the **NEXT** and **PREV** key to increase or decrease the value of the single digit, use the **ENTER** key to move the cursor to the next digit, use the **ESC** key to move back to the previous digit. When the string **"UPDATE?"** appears on the display you can use the **ENTER** key to accept the new password or the **ESC** key to abort the password definition.

When all digits are set to zero, the password is disabled.

# ADDENDUM FOR COMETER OR INDICATOR WITH HART PROGRAMMING CAPABILITY AND PROMETER - PROGRAMMABLE INDICATOR

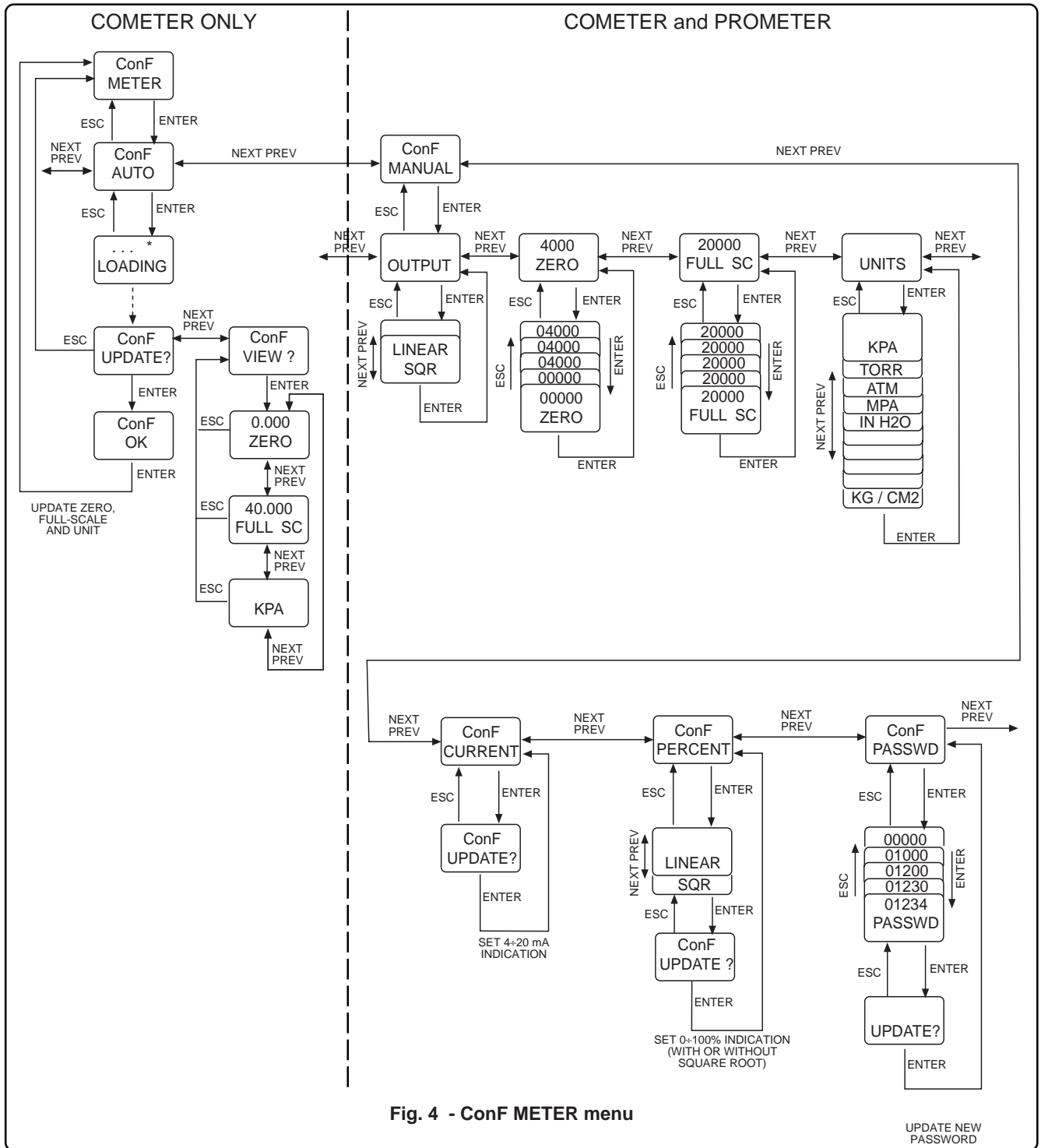

Fig. 4 - ConF METER menu

The other options under ConF METER menu are:

### ConF AUTO

By selecting this option, the CoMeter is automatically updated with the LRV, URV and Unit of the HART transmitter connected. Before accepting the transmitter configuration by pressing ENTER at the request "ConF UPDATE?", it is possible to view the LRV (ZERO), the URV (FULL SC) and the UNIT.

If the output transfer function of the transmitter is not linear, ProMeter and CoMeter show the message: **ConF NO\_LIN** and the user cannot update the configuration.

It is necessary to change the output transfer function of the transmitter to linear.

See Fig. 4 - "ConF METER" menu, for ConF AUTO procedure.

### ConF MANUAL

The selection of MANUAL configuration allows the user to define manually CoMeter and ProMeter configuration, i.e. define the LRV (ZERO), the URV (FULL SC), and the UNIT, as well as to decide for a LINEAR on SQR output function. LRV and URV can have a value between -99999 and +99999. Refer to Fig. 4 - ConF METER menu for detail on the procedure. For having the CoMeter to display the analog output current or the output percentage, select respectively:

### ConF CURRENT and ConF PERCENT

# ADDENDUM FOR COMETER OR INDICATOR WITH HART PROGRAMMING CAPABILITY AND PROMETER - PROGRAMMABLE INDICATOR

Under **ConF PERCENT** option, the user can decide for linear or SQR output. When SQR output is selected, the output is linear from 0 to 20% (to 4% of input). Refer to Fig. 4 - ConF METER for details on the procedures.

## ConF XMTR - TRANSMITTER CONFIGURATION (CoMeter only)

Four are the operations under the ConF XMTR menu: **CONF**, **TRIM**, **REVIEW** and **PV**.

By pressing ENTER on the ConF XMTR menu, the string **LOADING** appears on the display, with the blinking star (\*) indicating communication activity, i.e. the CoMeter is reading the transmitter information.

See below a list of the available operation under the selected option:

Then the **CONF** option appears.

Using PREV or NEXT key, the user can select **CONF**, **TRIM**, **REVIEW** or **PV** option, and with the ENTER key he moves into the menu.

When entering CONF and TRIM menu a message "**LOOP IN\_MAN**" appears to remind that a modification can change the transmitter output, so for security the loop should be put in Manual.

CONF menu	TRIM menu	REVIEW menu	PV menu
Change LRV Change URV Change DAMPING Change UNITS Change OUTPUT	Reranging (RERANG.) Loop test (LOOPST) Output trim (OUTTRIM) Zero adjustment (SNSZERO)	TAG 8 Final Assembly Nr. (XMTR N.) Sensor Serial Nr. (SENS N.) Up/Down scale (UP/DOWN) UNITS LRV URV LRL (See Sensor Units) URL (See Sensor Units) DAMPING OUTPUT	Primary variable (PRIMARY) Secondary variable (2ND) Tertiary variable (3RD) Fourth variable (4TH)

Use PREV or NEXT key to scroll through the options and ENTER key to change or view the values.

The procedure to change the numeric value remains the one already explained for PASSWORD operation, i.e., the cursor starts blinking on the most significant digit, then use the NEXT and PREV key to increase or decrease the value of the single digit (the minus sign(-) automatically appears or disappears when the value increases above 9 or decreases below 0, as well as for the decimal point(.). Use the ENTER key to move the cursor to the next digit, use the ESC key to move back to the previous digit.

An ENTER on the last digit will cause the value to be sent to the transmitter.

Refer to figures 5, 6, 7 and 8 for details.

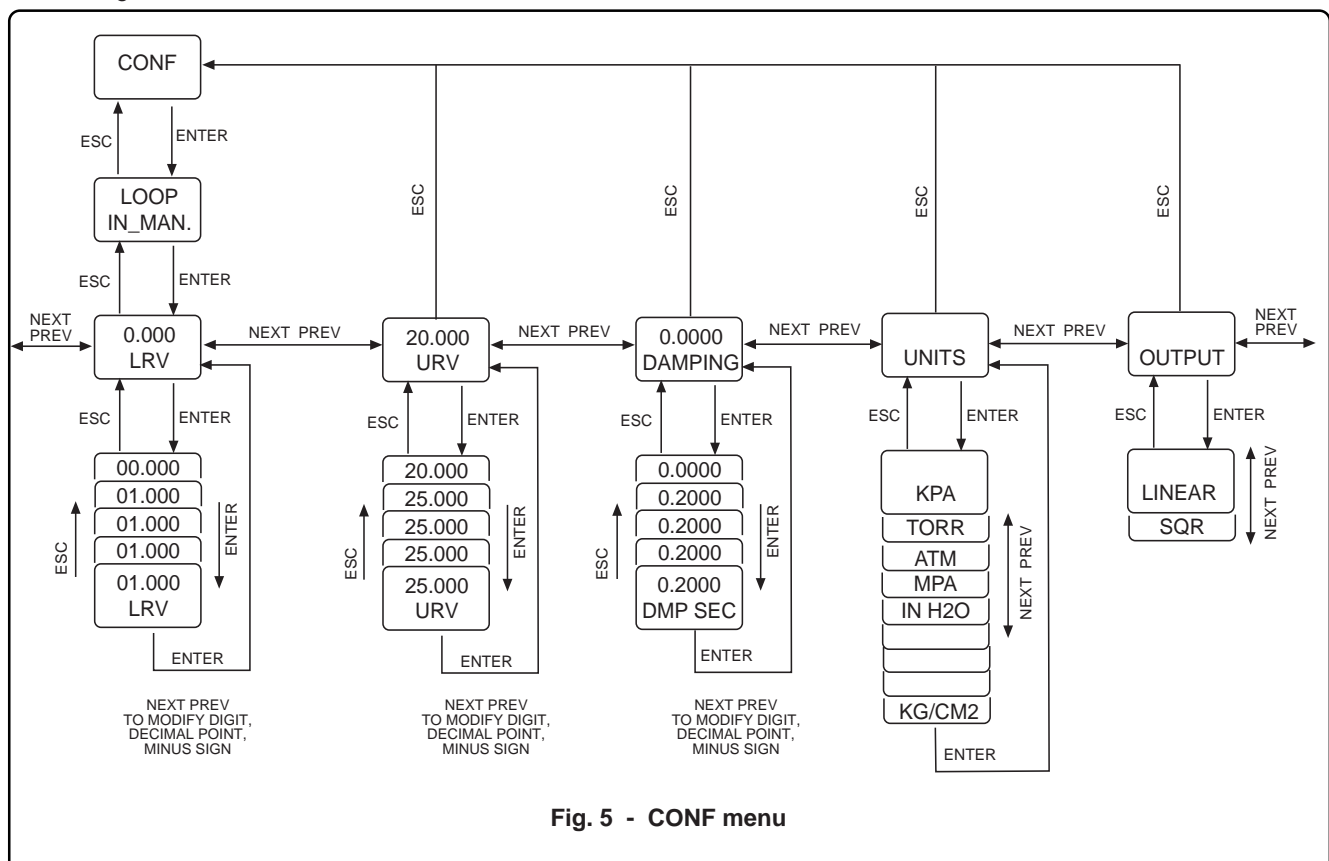

Fig. 5 - CONF menu

# ADDENDUM FOR COMETER OR INDICATOR WITH HART PROGRAMMING CAPABILITY AND PROMETER - PROGRAMMABLE INDICATOR

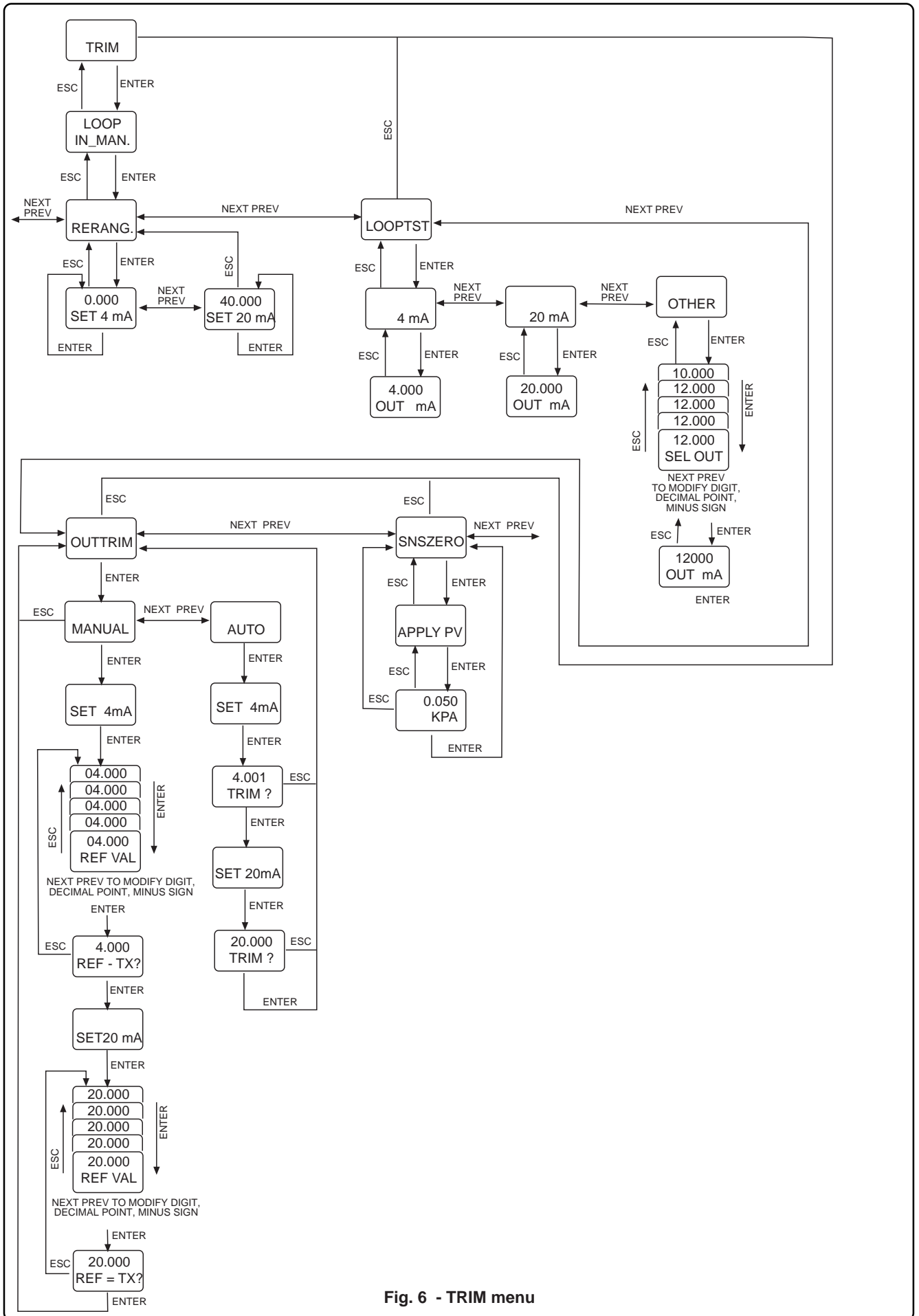
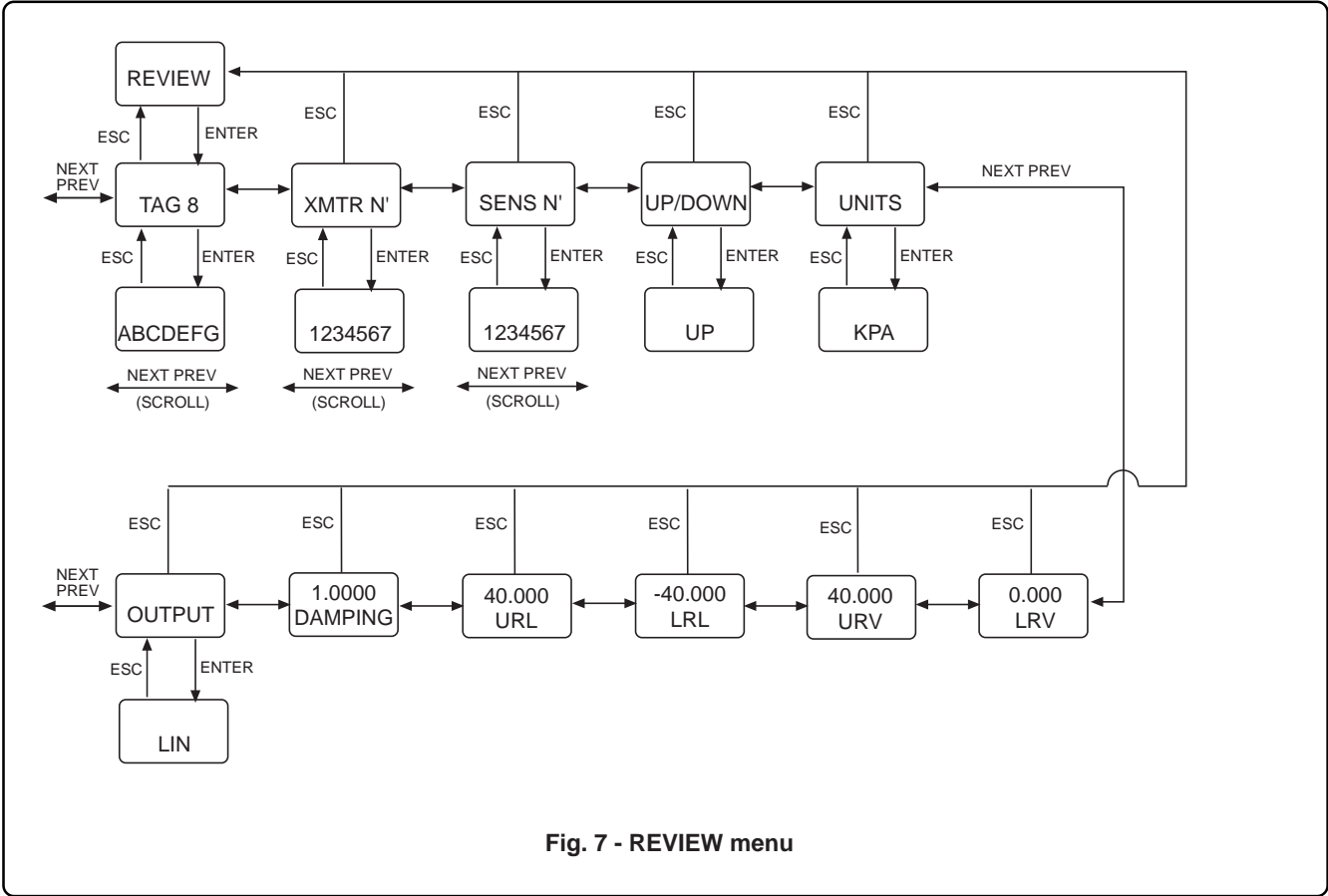
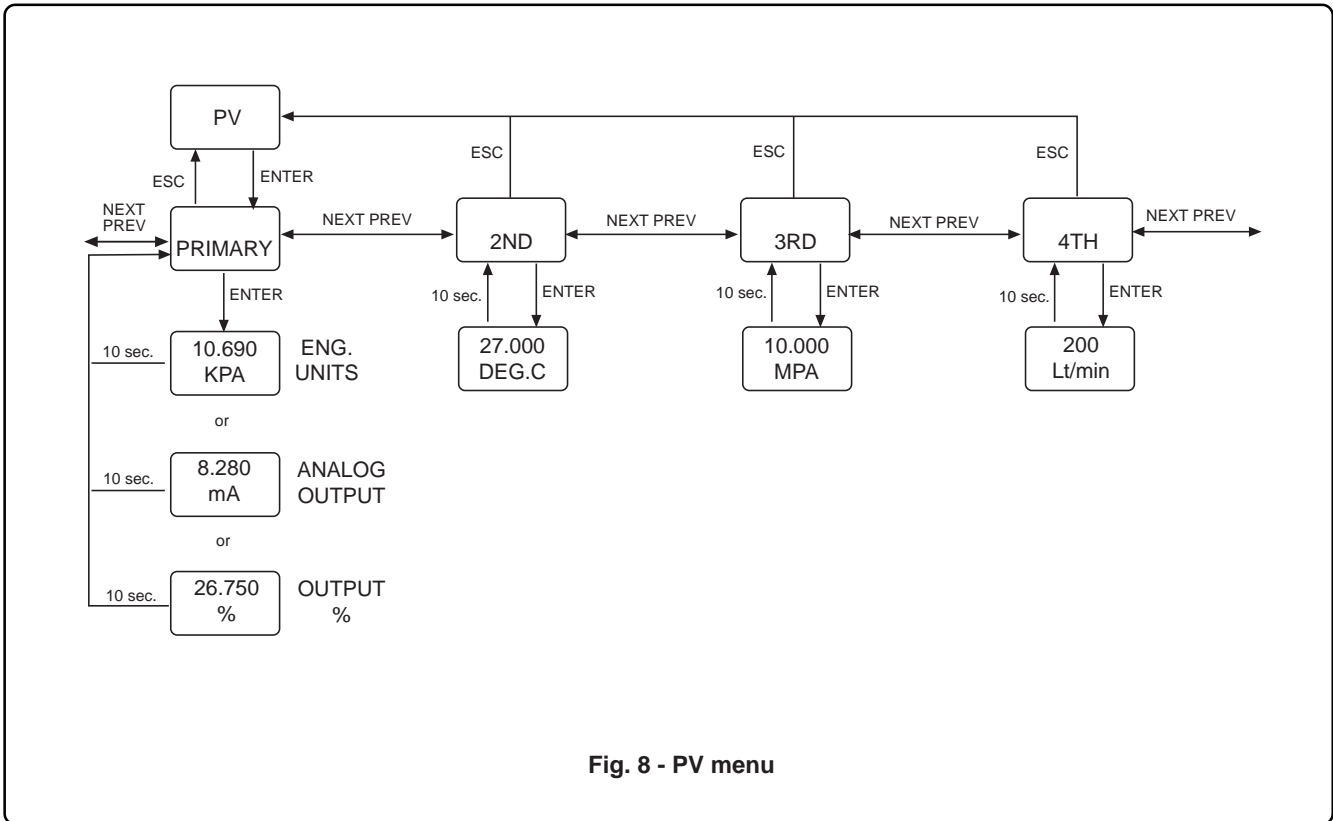

Fig. 6 - TRIM menu

**ADDENDUM FOR COMETER OR INDICATOR WITH HART PROGRAMMING CAPABILITY  
AND PROMETER - PROGRAMMABLE INDICATOR**



**Fig. 7 - REVIEW menu**



**Fig. 8 - PV menu**

# ADDENDUM FOR PV-SCALING OPERATION

PV-scaling operation can be used to align the "zero" of the process with the "zero" reading of the transmitter. A configuration tool must be used to perform this operation through digital communication.

## 1) PV scaling for analog + HART Safety version

There are two different ways to perform a PV-scaling.

Method 1: apply to the transmitter a pressure that corresponds to the scaling value (offset) you have to apply to the reading and perform the operation using the configuration tools. The operation is called SET PV ZERO (see example 1).

Method 2: calculate the scaling value (offset) and apply it to the transmitter following the operation available on the configuration tool. With this method it is possible to perform a scaling operation even for a value different than zero. The operation is called SET PV VALUE (see example 2).

Effect of the PV-scaling operation:

An example can better explain the effect of the scaling action.

### Example n° 1

the transmitter is calibrated at:

LRV = 0 mbar  
URV = 200 mbar

the transmitter model has the following limits of operation:

LRL = -400 mbar  
URL = +400 mbar

For the effect of a transmitter's capillary, connected to a tank, there is a pressure of 80 mbar when the tank is empty, i.e. the transmitter's reading is 80 mbar.

In order to eliminate the pressure caused by the fluid inside the capillary, you can perform a PV scaling for compensating/scaling the reading for these 80 mbar. The result of this operation is:

the transmitter's reading is now 0 mbar.  
offset is -80 mbar and must be considered that while the limits of the transmitter remains:  
LRL = -400 mbar  
URL = +400 mbar

and the calibration does not change

LRV = 0 mbar  
URV = 200 mbar

The configuration tools allows you to evaluate the new operative limits:

operative LRL = -480 mbar  
operative URL = +320 mbar

### Example n° 2

the transmitter is calibrated at:

LRV = 0 mbar  
URV = 200 mbar

the transmitter model has the following limits of operation:

LRL = -400 mbar  
URL = +400 mbar

the transmitter is reading:

PV = 100 mbar

and you know the process value is 50 mbar.

You can apply this 50 mbar for your PV scaling operation, with similar effect as per the previous example:

PV reading = 50 mbar

offset = 50 mbar so that while the limits of the transmitter remains:

LRL = -400 mbar  
URL = +400 mbar

with no change for the calibration, the configuration tools allows you to display the new operative limits:

operative LRL = -450 mbar  
operative URL = +350 mbar

When requested it is possible to reset the value actually applied as offset.

**When an offset is defined, the trimming operations are disabled and can be rehabilitated only by eliminating the scaling, i.e. setting the offset to 0.**



**WARNING.** In order to ensure the correct operation of the transmitter, after the calibration procedure the device must be put in operating condition as described in Section Commissioning and Configuration Issues.

## ADDENDUM FOR "SURGE PROTECTION" OPTION OF THE TRANSMITTERS



### WARNING - Note for Hazardous Area Installation

For the Pressure Transmitter with surge protector must be additional considered:

- 1 The transmitter has to be supplied from a voltage source which is safely separated from mains (galvanic separation).
- 2 The potential equalization for the entire cable link must be guaranteed since the intrinsic safety circuit of the transmitter is grounded.

### GENERAL DESCRIPTION

This option provides a built-in surge protection circuit.

The surge protector is designed to dissipate large quantities of electrical energy which have been induced in a transmission line. The option is suitable to protect up to 2500 V (5 kA discharge current) of 8µs rise time/20µs decay to half value.

These large quantities of energy can be induced in the signal transmission line by lightning discharge in the area or by nearby electrical equipment.

The dissipation of this energy prevents damage to transmitter circuitry connected to the transmission line.

**The surge protector will not protect the instrument in case of a direct lightning strike.**

The surge protector board is located inside the terminal block of the transmitter (see drawing).

The circuit is designed to operate and recover automatically. It does not require periodic testing or adjustment.

### FITTING PROCEDURE (refer fig. 1)



**CAUTION : This procedure should not be carried out on the field site.**

- a) Remove the transmitter cover of the field connections side.
- b) Unplug the built-in indicator, if present.
- c) Unscrew the two Phillips screws (M 4 x 18 mm) which secure the terminal block and pull it off the housing.
- d) Unweld the + and - wires which connect the two RF (radio frequency) filters, on the back of the terminal block.
- e) Fit properly the surge protector p.c. board and secure it by a self-tapping screw (M 2.9 x 6mm)
- f) Secure the two +/- eyelet terminals to +/- holes on the back of the terminal block, by a welding operation.
- g) Secure the two +/- wire eyelet terminals of the RF filters to the +/- bushes of the p.c. board by a welding operation.
- h) Connect the wire eyelet terminal of the Surge Protector to the dedicated ground connection below terminal block, using a provided self tapping screw M4x8 mm and relevant washers.
- i) Reinstall the terminal block and stick on the notice label in the proper position.
- l) Plug the built-in indicator, if used.
- m) Refit the cover.

Refer to Fig. 1 and also follows the indication in the figures 2a and 2b.

In the first one (2a) you can see the terminal block connection when there is no surge protector applied.

In the latter (2b) you can see the terminal block connection when surge protector is in!



**NOTE** - The Surge Protector is suitably provided with the necessary installation screws and the notice label.

Adding the unit to an existing transmitter will affect the power supply requirement for a minimum added operating voltage of 1.8 V d.c.

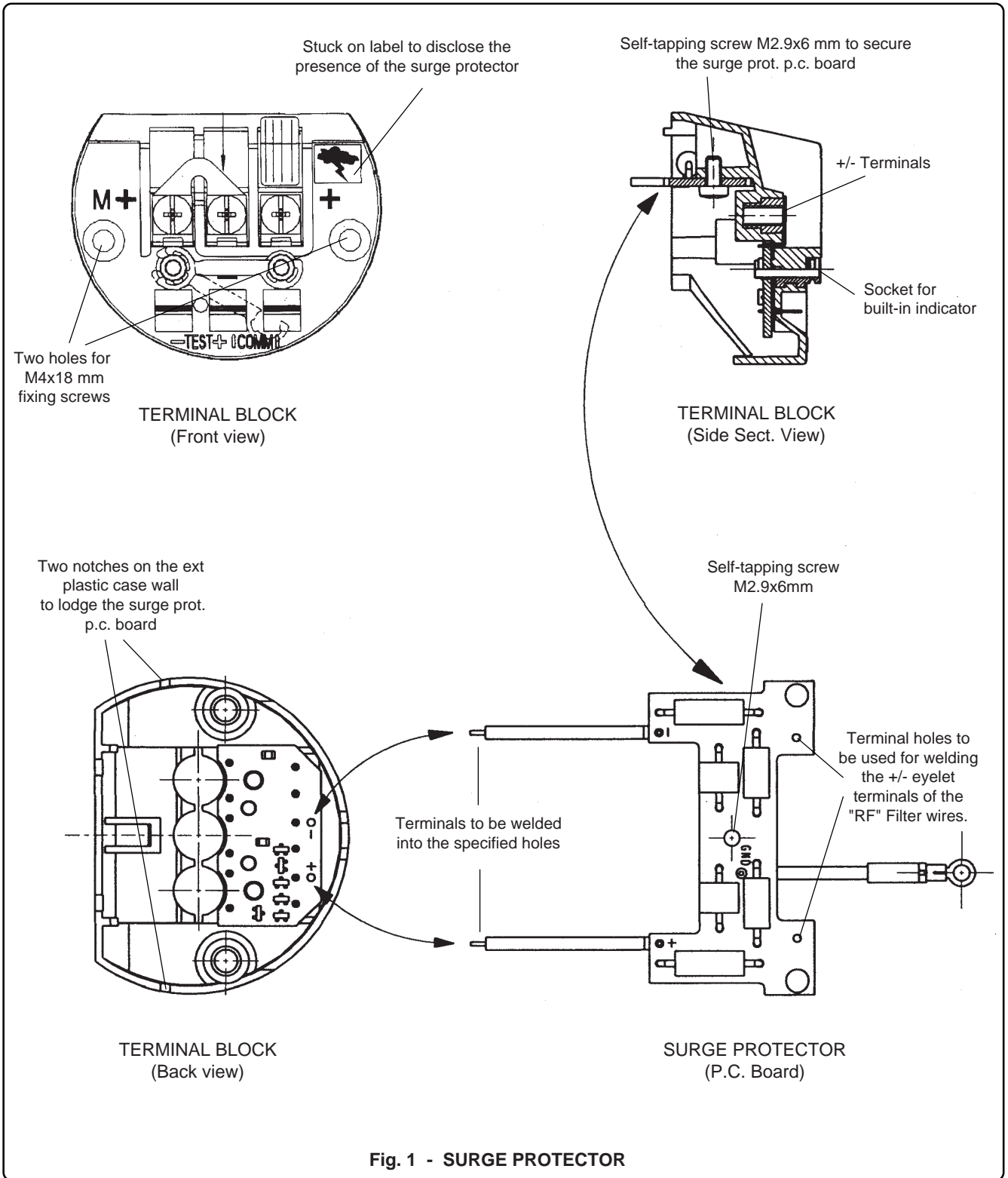
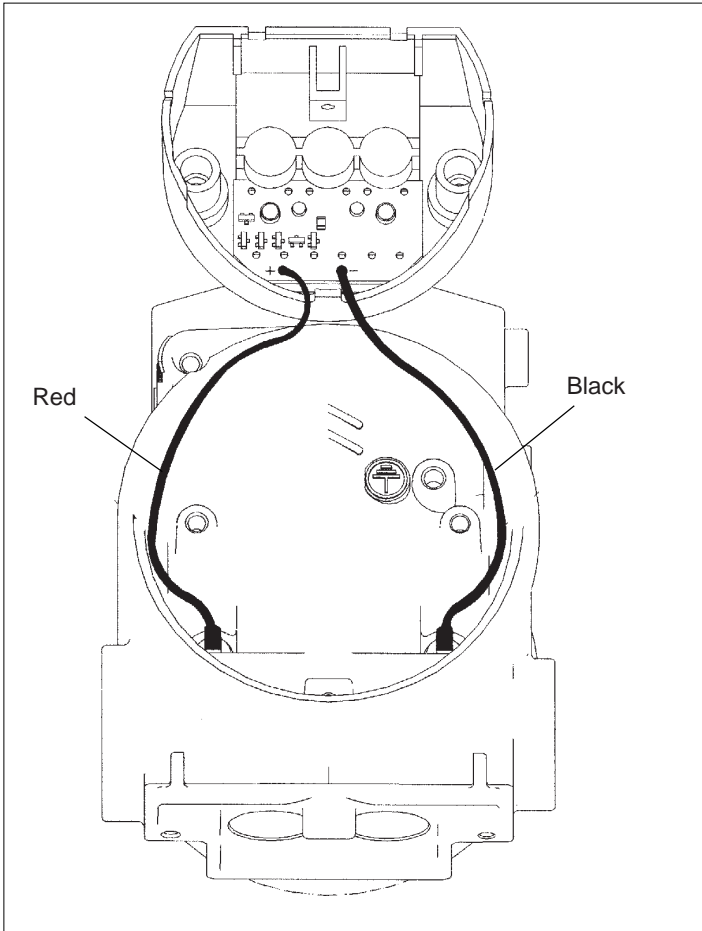

Fig. 1 - SURGE PROTECTOR

**... ADDENDUM FOR "SURGE PROTECTION" OPTION OF THE TRANSMITTERS**

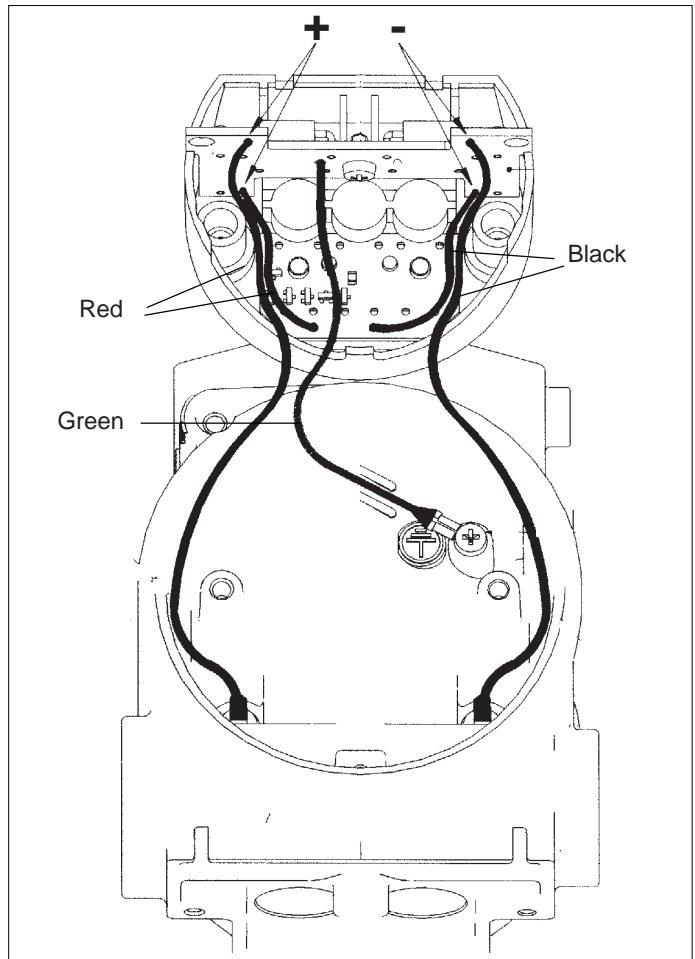

**Fig. 2a**  
**Connection for terminal block and housing.**

Note: Before to fix the terminal block to the housing put the two wires in the position as shown above, in order to avoid any damages.

**Fig. 2b**  
**Connection for terminal block and housing, with surge protection.**

Note: Before to fix the terminal block to the housing put the two wires in the position as shown above, in order to avoid any damages.



# ADDENDUM FOR SELECTABLE OUTPUT FUNCTIONS

## GENERAL DESCRIPTION

The 2600T Series Pressure Transmitter can be selected with a linear, a "polynomial" output function, for input linearization using a 5th order polynomial function, or for input linearization using 2 polynomial functions of 2nd order. Also a Constant Current function can be chosen for loop or associated equipment test.

### 1.0 LINEAR

Using this function, the relationship between the input (measured value), expressed in % of the calibrated span and the output is linear, e.g. at 0% input, corresponds 0% output (4mA), at 50% input corresponds 50% output (12mA) and at 100% input corresponds 100% output (20mA). Available for analog and analog + HART version.

### 2.0 POLYNOMIAL 1 (5th order)

#### Available for analog + HART version

The polynomial function, applied to the transmitter input (x) expressed in % of the calibrated span, has the following form:

$$\text{Out} = \pm A_0 \pm A_1(x) \pm A_2(x^2) \pm A_3(x^3) \pm A_4(x^4) \pm A_5(x^5)$$

where (x) and Out should be normalized in the range 0 to 1 for calculation purpose, with following Out meaning:

Out = 0 means Analog out 4 mA

Out = 1 means Analog out 20 mA

This function can be used for linearization purpose: the user can plot the characteristic curve of the input and find, using a mathematical method, the parameters of the polynomial that better approximate the plotted curve. Check, after the calculation, if the maximum error is compatible with the application.

The following are some application examples.

#### 2.1 CYLINDRICAL VESSEL

Using the polynomial function applied to a level transmitter installed in a horizontal cylindrical vessel it is possible to transmit the measure of level in term of partial volume. Some different cases should be considered:

a) Cylindrical vessel with flat ends (not often used. Fig. 1a). Transmitter measuring the whole vessel height.

The following polynomial gives the area of the circular section in relation to the height h (height of the liquid in the vessel).

$$\text{Out} = -0.02 + 0.297 h + 2.83 h^2 - 4.255 h^3 + 3.5525 h^4 - 1.421 h^5$$

Being both the input h and the output Out normalized, i.e. in the range 0 to 1 (or 0% to 100%), the vessel diameter corresponding to a circular area equal to 1 (100%) will be "normalized" by a "K" factor of the following value:

$$K = 2 \cdot \sqrt{1/\pi} = 1.12838$$

The volume of the liquid contained in the vessel, at height = h will be

$$V = \text{Out} \cdot (d/1.12838)^2 \cdot L$$

where d = vessel diameter and L = vessel length.

The non conformity error is within 0.1% between 0.5% and 99.5% of h, 0.2% at 0% and 100%.

b) Cylindrical vessel with hemispherical ends (see Fig. 1b). Transmitter measuring the whole vessel height.

The same polynomial can be used also for the cylindrical vessel with hemispherical ends. To obtain the volume contained in the vessel can be used the following empirical formula:

$$V = \text{Out} \cdot (d/1.12838)^2 \cdot (L + 2/3 d)$$

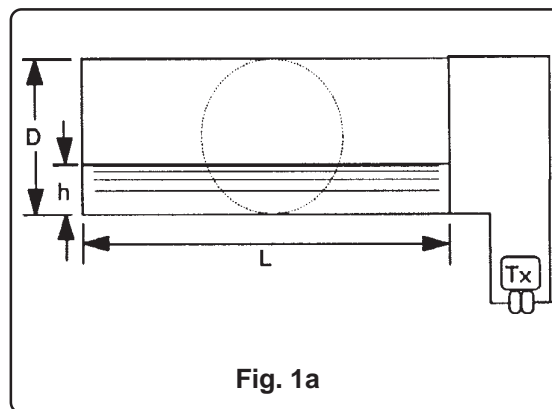

Fig. 1a

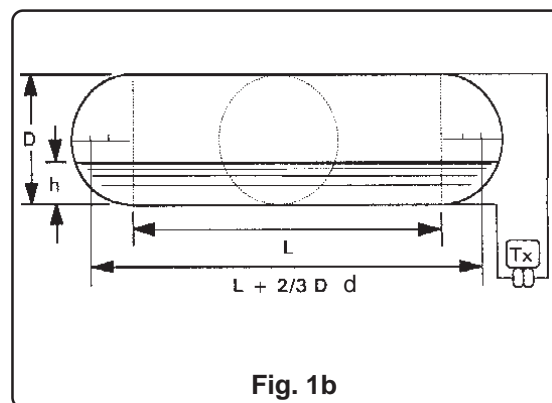

Fig. 1b

The non conformity error depends on the ratio between diameter and length of the vessel: for ratio  $\geq 5$  to 1 the error is  $\leq 0.25\%$ . The polynomial found with mathematical method gives an error of  $\pm 0.15\%$ .

c) Cylindrical vessel with elliptical or pseudoelliptical ends (see Fig. 1c). Transmitter measuring the whole vessel height.

The same polynomial can be used also for the cylindrical vessel with elliptical or pseudoelliptical ends. To obtain the volume contained in the vessel can be used the following empirical formula:

$$V = \text{Out} \cdot (d/1.12838)^2 \cdot (L + 2/3 m)$$

where m is the length of the minor ellipse axis (see Fig.1c)

The non conformity error depends on the ratio between the diameter and the length of the vessel: for ratio  $\geq 5$  to 1 the error is  $\leq 0.25\%$ . The polynomial found with mathematical method gives an error of  $\pm 0.15\%$ .

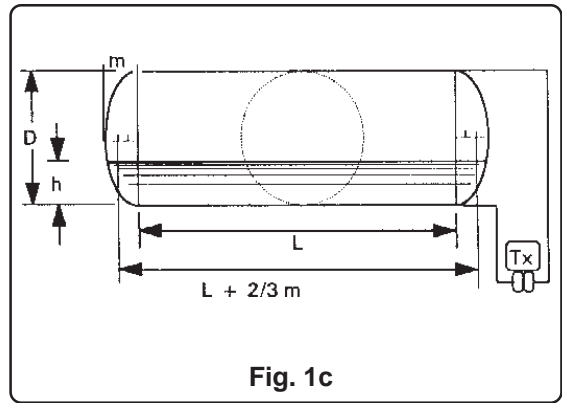

Fig. 1c

## 2.2 SPHERICAL TANK

Spherical tank (see Fig.1d). Transmitter measuring the whole vessel height.

The following polynomial gives the volume of the spherical section in relation to the height h of the liquid in the tank.

$$\text{Out} = 3 h^2 - 2 h^3$$

This formula is geometrical and then his conformity is perfect.

Being both the input h and the output Out normalized, i.e. in the range 0 to 1 (or 0% to 100%), the sphere diameter D corresponding to a volume equal to 1 (100%) will be "normalized" by a "K" factor of the following value:

$$K = 2 \cdot \sqrt[3]{3 / (4 \pi)} = 1.2407$$

The volume of the liquid contained in the tank, at height = h will be

$$V = \text{Out} \cdot (D/1.2407)^3$$

where D = sphere diameter .

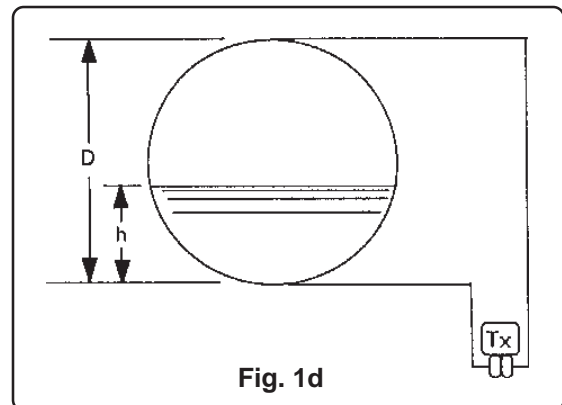

Fig. 1d

## 2.3 CYLINDRICAL VESSEL AND SPHERICAL TANK WITH PARTIAL LEVEL MEASUREMENT

Cases a) to d) but with partial level measurement (Fig. 2a)

In these cases two methods can be used:

- 1) Plot the changes in volume in relation to the level changes and, using a mathematical method, find the relevant polynomial.
- 2) Use the polynomial coefficients for cases a) to d) and calibrate the transmitter range to cover the full diameter of the vessel or tank: the changes in volume for the h changes between  $h_0$  and  $h_{\max}$  will be correct. Of course the transmitter will transmit, when the level is  $\leq h_0$ , the volume corresponding to  $h_0$ : the same apply for level  $\geq h_{\max}$ . All transmitted volumes are % of the total volume of the vessel.

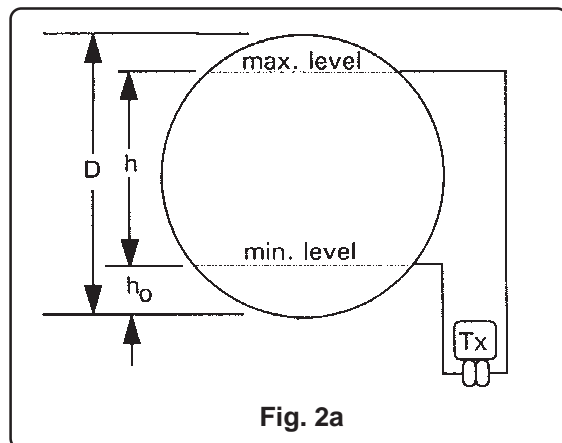

Fig. 2a

If it is required the partial volume starting from  $h_0$  (i.e. the volume at  $h_0 = 0$ ) then the  $A_0$  coefficient should be equal to the polynomial solved for  $h_0$  with negative sign: for example for  $h_0 = 20\%$

$$A_0 = -0.02 + 0.297 \cdot 0.2 + 2.83 \cdot 0.2^2 - 4.255 \cdot 0.2^3 + 3.5525 \cdot 0.2^4 - 1.421 \cdot 0.2^5 = -0.14179$$

The polynomial coefficients for the example will be:

$$\text{Out} = -0.14179 + A_1 h + A_2 h^2 - 4.255 h^3 + 3.5525 h^4 - 1.421 h^5$$



**Note** : The accuracy of all above numerical values can not be guaranteed.



### General notes for level measurement

The level transmitter calibration is effected by the transmitter installation conditions, i.e. if the reference connection is empty (dry leg) or liquid filled (wet leg). In the first case (dry leg) the calibration is affected by the specific gravity of the measured liquid and the atmosphere above the liquid at process condition, whereas in the second case (wet leg), it is affected by the specific gravity of the liquid in the connecting pipe(s).

## ... ADDENDUM FOR SELECTABLE OUTPUT FUNCTIONS

### 3.0 POLYNOMIAL 2 (Two polynomial functions of 2nd order) - Available for Analog + HART version - Fig. 2b

Analog Output transfer function can also be defined as a two polynomial function. Both polynomials are of 2nd order. So two different polynomial functions are used:

$$\text{Out} = [\pm A_0 + A_1(x^1) \pm A_2(x^2)] + [\pm B_0 + B_1(x^1) \pm B_2(x^2)]$$

Here the polynomial with A coefficients is used for X from 0 to a K value, and the second one with B coefficients for X greater than the K value.

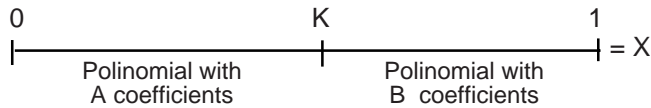

Ax and Bx terms of the polynomials have to be calculated according to the shape of the vessel.

A PC based software tool is available for polynomial coefficients definition.

### 4.0 CONSTANT CURRENT Available for analog + HART version

This output function, activated by a Configuration Tool, can be used to test the transmitter output, the integrity of the transmission loop and the calibration of associated equipment like receivers, recorders, etc.

When this function is activated the transmitter acts like a constant current generator: using the configuration tool the user can specify a fixed output current of 4 mA, 20 mA or any value between 4 and 20 mA.

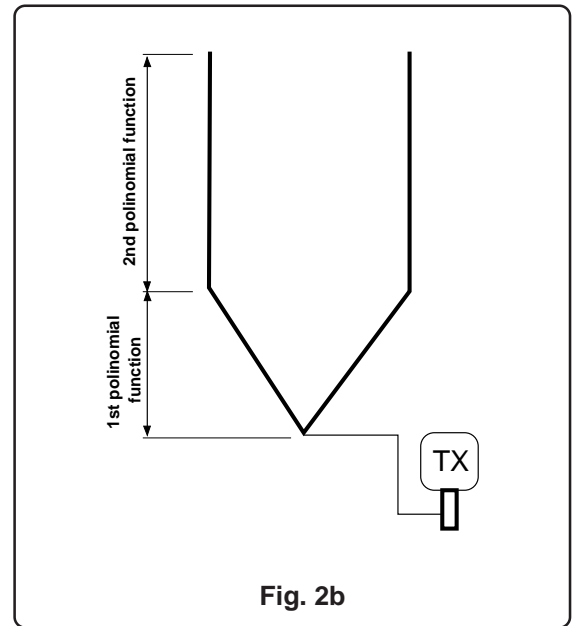

Fig. 2b

## ADDENDUM FOR OUTPUT % RERANGING

Sometimes, in case of tank level measurement, it becomes difficult to calculate the LRV or the URV of the transmitter, or to empty the tank for zero adjustment. So, not only with flange-mounted, but also with differential pressure transmitters using remote seals, the Output % Reranging operation helps the user during transmitter calibration.

When it is known the level of the tank, expressed in percentage, the liquid level, it is possible to input this percentage that automatically the transmitter recalculates its LRV and URV according to the new percentage value.

This can be done using a HART configuration tool on a 2600T Transmitter.

Two options are available as Output % Reranging operation:

- 1) OP Range Low where both LRV and URV are adjusted
- 2) OP Range High where only URV is change in accordance with the new input percentage

As example:

Actual level measured by the transmitter:

Transmitter output = 27%

Calibration : LRV = -125 mbar

URV = +340 mbar

a) New input level measurement (Option 1) = 30%

New calibration : LRV = -139.5 mbar

URV = +325.5 mbar

The transmitter output is now = 30%

Starting again from the initial settings:

Transmitter output = 27%

Calibration : LRV = -125 mbar

URV = +340 mbar

b) New input level measurement (Option 2) = 30%

New calibration : LRV = -125 mbar

URV = +291.5 mbar

The transmitter output is now = 30%

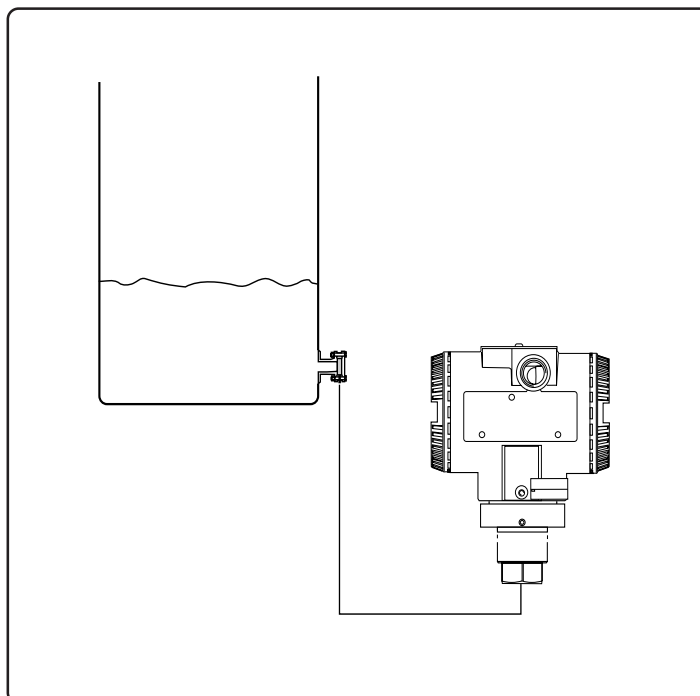

## **ADDENDUM FOR "EX SAFETY" ASPECTS AND "IP" PROTECTION (EUROPE)**

According to ATEX Directive (European Directive 94/9/EC of 23 March 1994) and relative European Standards which can assure compliance with Essential Safety Requirements, i.e., EN 50014 (General requirements) EN 50018 (Flameproof enclosures "d") EN 50020 (Intrinsic safety "i") EN 50284 (Equipments, group II, category 1G), the pressure transmitters of the 2600T SERIES have been certified for the following group, categories, media of dangerous atmosphere, temperature classes, types of protection. Examples of application are also shown below by simple sketches.

- a) Certificate ATEX II 1G, EEx ia IIC T5 (-40°C ≤ Ta ≤ +40°C)  
respectively, EEx ia IIC T4 (-40°C ≤ Ta ≤ +85°C)

TUV Certificate number TPS 04 ATEX 1 008.

The meaning of ATEX code is as follows:

- II : Group for surface areas (not mines)
- 1 : Category
- G : Gas (dangerous media)

(Note: the number close to the CE marking of the transmitter safety label identifies the Notified Body which carries out the surveillance for the production of the transmitter)

The other marking refers to the protection type used according to relevant EN standards:

- EEx ia : Intrinsic safety, protection level "a"
- IIC : Gas group
- T5 : Temperature class of the transmitter (which corresponds to 85°C max)  
with a Ta (ambient temperature) +40°C
- T4 : Temperature class of the transmitter (which corresponds to 135°C max)  
with a Ta (ambient temperature) +85°C

About the applications, this transmitter can be used in "Zone 0" (Gas) classified area (continuous hazard) as it is shown on the following sketch:

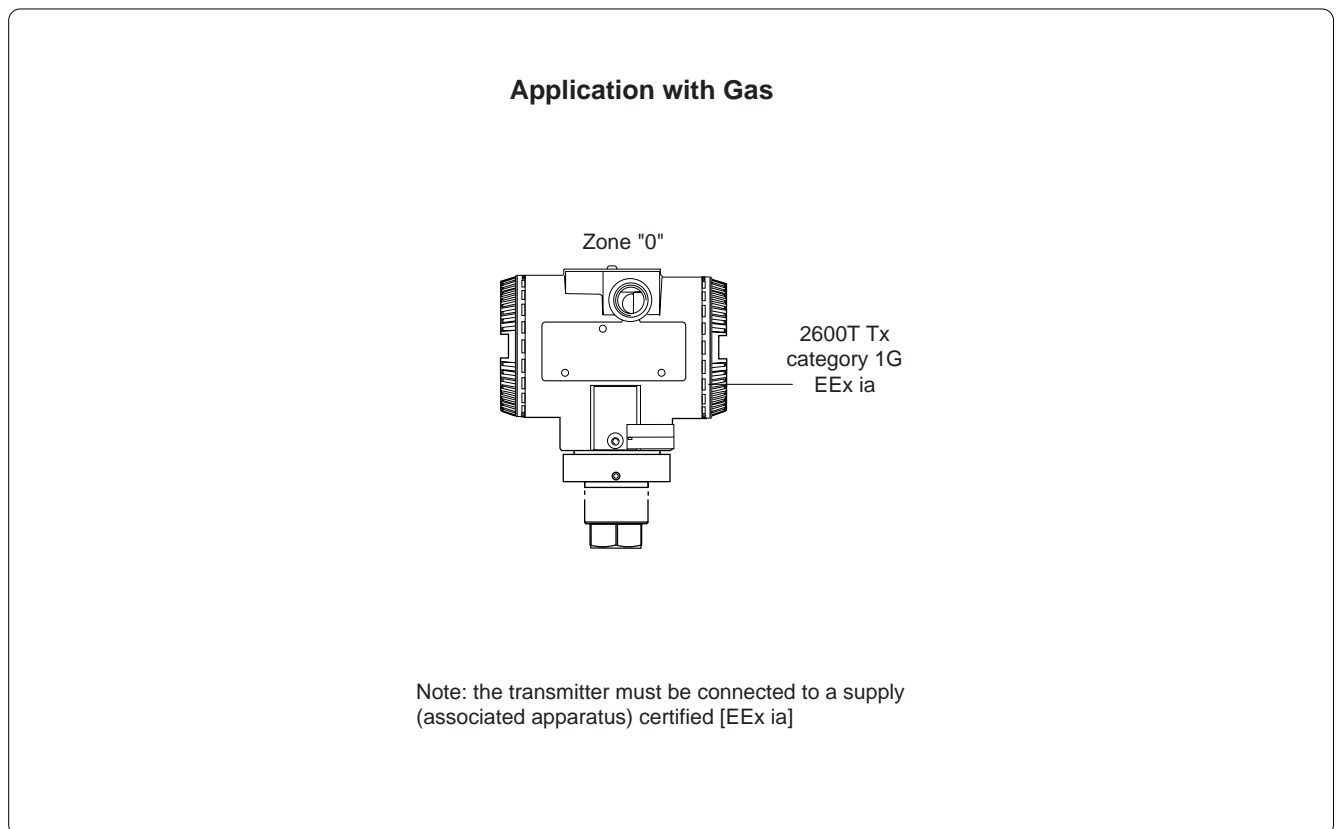

## ... ADDENDUM FOR "EX SAFETY" ASPECTS AND "IP" PROTECTION (EUROPE)

b) Certificate ATEX II 1/2 GD, EEx d IIC T6  
IP67 T85°C (-40°C ≤ Ta ≤ +75°C)

CESI Certificate number CESI 02 ATEX 027

The meaning of ATEX code is as follows:

- II : Group for surface areas (not mines)
- 1/2 : Category - It means that only a part of the transmitter complies with category 1 and a second part complies with category 2 (see next application sketch)
- G : Gas (dangerous media)
- D : Dust (dangerous media)
- T85°C: Maximum surface temperature of the transmitter enclosure with a Ta (ambient temperature) +75°C for Dust (not Gas) with a dust layer up to 50 mm depth.

Note: the number close to the CE marking of the transmitter safety label identifies the Notified Body which carries out the Surveillance for the production of the transmitter.

The other marking refers to the protection type used according to relevant EN Standards:

- EEx d: Flameproof
- IIC : Gas group
- T6 : Temperature class of the transmitter (which corresponds to 85°C max) with a Ta (ambient temperature) +75°C

About the applications, this transmitter can be used in Zone "0" (Gas) classified areas (continuous hazard) with its "process part" only, whereas the remaining part of the transmitter, i.e. its enclosure, can be used in Zone 1 (Gas), only (see sketch below). Reason of this is the process part of the transmitter (normally called primary transducer) that provides inside separation elements to seal off the electrical sensor from the continuously hazardous process, according to the EN50284 and EN50018. About Dust application, the transmitter is suitable for "Zone 21" according to the EN 50281 as it is shown on the relevant part of the sketch:

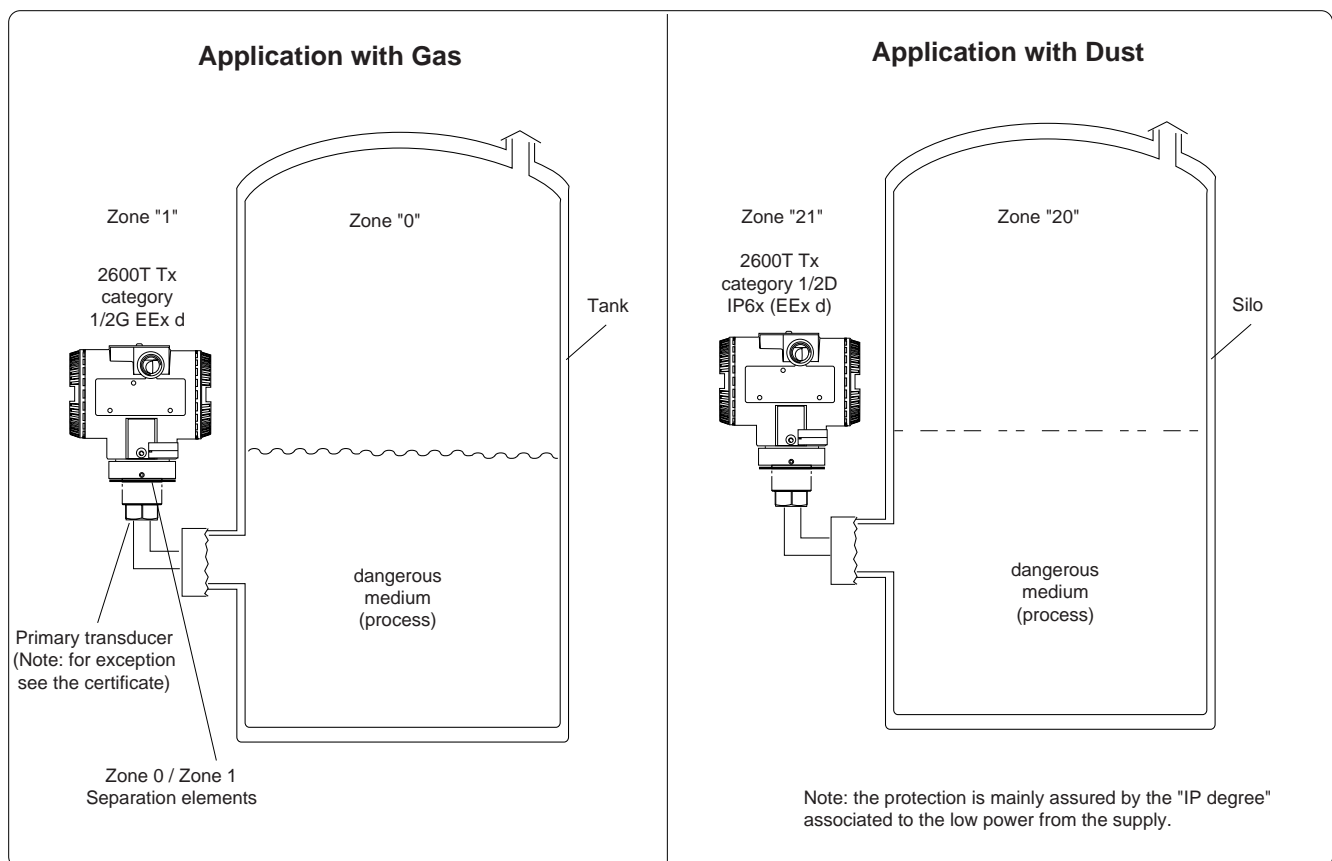

### IP code

About the degree of protection provided by the enclosure of the pressure transmitter, the 2600T SERIES has been certified IP67 according to EN 60529 standard (corresponding to IEC 529).

The first characteristic numeral indicates the protection of the inside electronics against ingress of solid foreign objects including dusts. The assigned "6" means an enclosure dust-tight (no ingress of dust).

The second characteristic numeral indicates the protection of the inside electronics against ingress of water. The assigned "7" means an enclosure water-protected against a temporary immersion in water under standardized conditions of pressure and time.



## EC DECLARATION OF CONFORMITY

We: ABB SACE S.p.A.  
Via Statale, 113  
22016 Lenno (Como)  
Italy

declares under our sole responsibility that the products:

*2600T EN Series (Transmitters models 262/264/266/268, Hand Held Terminal, Field Indicator) in all the communication configurations (4-20 mA + HART<sup>®</sup>, Profibus, Foundation Fieldbus, Safety)*

### are in conformity with the following standards:

**EN 61000-6-3 (2001)** Electromagnetic compatibility (EMC) - Generic standards - Emission standard for residential, commercial and light-industrial environments

according to: EN55022 (2001)

**EN 61000-6-2 (2001)** Electromagnetic compatibility (EMC) - Generic standards - Immunity for industrial environments

according to: EN 61000-4-2 (2001)  
EN 61000-4-3 (2002)  
EN 61000-4-4 (2001)  
EN 61000-4-5 (2001)  
EN 61000-4-6 (2001)

following the provisions of the EMC Directives 89/336/EEC and 93/68/EEC.

Lenno, 2<sup>nd</sup> January 2003

ABB SACE S.p.A.  
BU Instrumentation Technical Manager  
A. Moroni

ABB SACE S.p.A.

Business Unit Instrumentation

1001MK000 Uffici Commerciali/Sales Office:  
Via Statale, 113 - 22016 Lenno (CO) Italy  
Tel. +39 0344 58 111 - Fax +39 0344 56 278  
e-mail: abb.instrumentation@it.abb.com

Direzione e Uffici Amministrativi/Administration:  
Via L. Lama, 33 - 20099 Sesto S. Giovanni (MI) Italy  
Tel. +39 02 2414 1 - Fax +39 02 2414 3892  
e-mail: sace.ssg@it.abb.com

Sede legale/Registered Office:  
I-20124 Milano - Via Vittor Pisani, 16  
Tel.: +39 02 2414.1  
Capitale Sociale: € 60.000.000 i.v.  
Partita IVA/VAT n°: IT 00257710731  
Registro delle imprese di Milano e Codice  
Fiscale: 0109949 015 1  
R.E.A. Milano: 1066547+

Unità produttive/Factories:  
Lenno (CO)  
Ossuccio (CO)  
Sesto S. Giovanni (MI)



# PRODUCTS & CUSTOMER SUPPORT

## Products

### Automation Systems

- *for the following industries:*
  - Chemical & Pharmaceutical
  - Food & Beverage
  - Manufacturing
  - Metals and Minerals
  - Oil, Gas & Petrochemical
  - Pulp and Paper

### Drives and Motors

- *AC and DC Drives, AC and DC Machines, AC Motors to 1kV*
- *Drive Systems*
- *Force Measurement*
- *Servo Drives*

### Controllers & Recorders

- *Single and Multi-loop Controllers*
- *Circular Chart, Strip Chart and Paperless Recorders*
- *Paperless Recorders*
- *Process Indicators*

### Flexible Automation

- *Industrial Robots and Robot Systems*

### Flow Measurement

- *Electromagnetic Magnetic Flowmeters*
- *Mass Flow Meters*
- *Turbine Flowmeters*
- *Wedge Flow Elements*

### Marine Systems & Turbochargers

- *Electrical Systems*
- *Marine Equipment*
- *Offshore Retrofit and Refurbishment*

### Process Analytics

- *Process Gas Analysis*
- *Systems Integration*

### Transmitters

- *Pressure*
- *Temperature*
- *Level*
- *Interface Modules*

### Valves, Actuators and Positioners

- *Control Valves*
- *Actuators*
- *Positioners*

### Water, Gas & Industrial Analytics Instrumentation

- *pH, conductivity, and dissolved oxygen transmitters and sensors*
- *ammonia, nitrate, phosphate, silica, sodium, chloride, fluoride, dissolved oxygen and hydrazine analyzers.*
- *Zirconia oxygen analyzers, katharometers, hydrogen purity and purge-gas monitors, thermal conductivity.*

## Customer Support

We provide a comprehensive after sales service via a Worldwide Service Organization. Contact one of the following offices for details on your nearest Service and Repair Centre.

### Italy

ABB SACE spa  
Business Unit Instrumentation  
Tel: +39 0344 58111  
Fax: +39 0344 56278

### United Kingdom

ABB Limited  
Tel: +44 (0)1453 826661  
Fax: +44 (0)1453 827856

### United States of America

ABB Inc.  
Tel: +1 (0) 755 883 4366  
Fax: +1 (0) 755 883 4373

#### Client Warranty

Prior to installation, the equipment referred to in this manual must be stored in a clean, dry environment, in accordance with the Company's published specification.

Periodic checks must be made on the equipment's condition. In the event of a failure under warranty, the following documentation must be provided as substantiation:

1. A listing evidencing process operation and alarm logs at time of failure.
2. Copies of all storage, installation, operating and maintenance records relating to the alleged faulty unit.

ABB has Sales & Customer Support  
expertise in over 100 countries worldwide

[www.abb.com/instrumentation](http://www.abb.com/instrumentation)

The Company's policy is one of continuous product  
improvement and the right is reserved to modify the  
information contained herein without notice.

Printed in Italy (07.04)

© ABB 2004



**ABB Ltd**

Howard Road, St. Neots  
Cambridgeshire, PE19 3EU  
UK  
Tel: +44(0)1480 475321  
Fax: +44(0)1480 217948

**ABB Inc.**

125 E. County Line Road  
Warminster, PA 18974  
USA  
Tel: +1 215 674 6000  
Fax: +1 215 674 7183

**ABB SACE spa**

Business Unit Instrumentation  
Via Statale 113  
22016 Lenno (CO) Italy  
Tel: +39 0344 58111  
Fax: +39 0344 56278