

# Model 364DR Differential Model 364PR Gauge

## ABB 364 model The common sense pressure transmitter



### **Best in class total performance**

- long term stability of 0.15% for 10 years
- base accuracy of 0.06%

### **The space saver**

- the solution for multiple installations in reduced spaces

### **The innovative approach to DP flow measurement**

- bi-directional flow capability with double low flow cut-off
- double totalization, on board

### **The common sense construction**

- all stainless body and housing
- Hastelloy process diaphragms

### **The common sense approach to leakage prevention**

- one piece stainless steel design process chambers
- gasket free sensor coupling with conventional connections

### **The user friendly transmitter**

- user accessible wiring termination with built-in surge protection
- on board LCD display with intuitive menu navigation
- “easy setup” for quick commissioning
- multilanguage menu selection

## General Description

Models detailed in this data sheet apply for those transmitters which include one or two remote seal(s) connected via a capillary to the transmitter sensor. Depending on the selected ordering code the following models are available:

- a) model 364DR which allows a differential measurement using either two remote seals of same type and size or one remote seal (on positive or negative side) and a standard threaded connection direct or through adapter, for the wet or dry leg on the side opposite to seal.
- b) model 364PR allows gauge measurement with the reference side at atmosphere and the other side which can be the positive or negative (high or low pressure side) features the required remote seal.

The table on the right details the types of standard seal which can be combined with 364xR transmitters (the mnemonic is used as reference in the compatibility table).

Refer to S364 seal data sheet for all data and details relevant to seal element.

All following specification data apply for identical characteristics of the two sides when the transmitter is differential with two seals.

Model	Seal type	Size	Mnemonic
S364W	Wafer Wafer (food)	1 1/2in / DN40 2in / DN50 3in / DN80	P1.5 P2 P3
S364C	Chemical tee flanged	3in	P3
S364A S364E S364R	Flanged flush diaphragm (also Ring Joint)	1 1/2in (RJ only) 2in / DN50 3-4in / DN80-100	P1.5 P2 P3
	Flanged extended diaphragm	2in / DN50 3in / DN80 4in / DN100	E2 E3 P3
S364U	Union	1 1/2in	Z1.5
S364T	Threaded off-line	2 1/2in	T2.5
S364M	Flanged off-line	2 1/2in	T2.5
S364S	Union nut, Triclamp, Cherry Burrel, Sanitary, Aseptic	2in / F50	S2
		3in / F80	S3
		4in	S3

## Functional Specifications

### Range and span limits

Sensor Code	Upper Range Limit (URL)	Lower Range Limit (LRL)		Minimum span
		364DR differential measure	364PR gauge measure	
<b>B</b>	4kPa 40mbar 16inH <sub>2</sub> O	-4kPa -40mbar -16inH <sub>2</sub> O		0.2kPa 2mbar 0.8inH <sub>2</sub> O
<b>E</b>	16kPa 160mbar 64inH <sub>2</sub> O	-16kPa -160mbar -64inH <sub>2</sub> O	-16kPa -160mbar -64inH <sub>2</sub> O	0.54kPa 5.4mbar 2.14inH <sub>2</sub> O
<b>G</b>	65kPa 650mbar 260inH <sub>2</sub> O	-65kPa -650mbar -260inH <sub>2</sub> O	-65kPa -650mbar -260inH <sub>2</sub> O	1.1kPa 11mbar 4.35inH <sub>2</sub> O
<b>H</b>	160kPa 1600mbar 642inH <sub>2</sub> O	-160kPa -1600mbar -642inH <sub>2</sub> O	0.07kPa abs 0.7mbar abs 0.5mmHg	2.67kPa 26.7mbar 10.7inH <sub>2</sub> O
<b>M</b>	600kPa 6bar 87psi	-600kPa -6bar -87psi	0.07kPa abs 0.7mbar abs 0.5mmHg	10kPa 0.1bar 1.45psi
<b>P</b>	2400kPa 24bar 348psi	-2400kPa -24bar -348psi	0.07kPa abs 0.7mbar abs 0.5mmHg	40kPa 0.4bar 5.8psi
<b>Q</b>	8000kPa 80bar 1160psi	-8000kPa -80bar -1160psi	0.07kPa abs 0.7mbar abs 0.5mmHg	134kPa 1.34bar 19.4psi
<b>S</b>	16000kPa 160bar 2320psi	-16000kPa -160bar -2320psi	0.07kPa abs 0.7mbar abs 0.5mmHg	267kPa 2.67bar 38.7psi

### Span limits

Maximum span = URL  
(can be further adjusted up to ± URL (TD = 0.5) for differential models, within the range limits)

IT IS RECOMMENDED TO SELECT THE TRANSMITTER SENSOR CODE PROVIDING THE TURNDOWN VALUE AS LOWEST AS POSSIBLE TO OPTIMIZE PERFORMANCE CHARACTERISTICS.

### Zero suppression and elevation

Zero and span can be adjusted to any value within the range limits detailed in the table as long as:

- calibrated span ≥ minimum span

### Damping

Selectable time constant : 0 to 32 s  
This is in addition to sensor response time

### Turn on time

Operation within specification in less than 1s with minimum damping.

### Insulation resistance

> 100MΩ at 1000VDC (terminals to earth)

Sensor Code	Compatibility (allowed seal types with maximum capillary length (m) in brackets) versus measurement configuration	
	Differential (two seals)	gauge and differential (one seal)
<b>B</b>	P3 (1.5) E3 (1●), T2.5 (1●), S3 (1.5●)	
<b>E</b>	P3 (3) E3 (2●), T2.5 (2●), S3 (3●)	P3 (1) S3 (1)
<b>G</b>	P2 (3), P3 (6), E2 (2), E3 (4), T2.5 (3), S2 (1●), S3 (6)	P2 (2), P3 (4), E3 (3), T2.5 (2) S3 (4)
<b>H</b>	P1.5 (4), P2 (8), P3 (8), E2 (6), E3 (6), T2.5 (6), S2 (3), S3 (10)	P1.5 (3), P2 (6), P3 (10), E2 (4), E3 (8), Z1.5 (3), T2.5 (6), S2 (2), S3 (10)
<b>M</b>	P1.5 (5), P2 (8), P3 (10 *), E2 (6), E3 (8), T2.5 (6), S2 (6), S3 (10)	P1.5 (5), P2 (8), P3 (10), E2 (6), E3 (8), Z1.5 (5), T2.5 (6), S2 (6), S3 (10)
<b>P</b>	P1.5 (5), P2 (8), P3 (10 *), E2 (6), E3 (8), T2.5 (6), S2 (6), S3 (10)	P1.5 (5), P2 (8), P3 (10), E2 (6), E3 (8), Z1.5 (5), T2.5 (6), S2 (6), S3 (10)
<b>Q</b>	P1.5 (5), P2 (8), P3 (10 *), E2 (6), E3 (8), T2.5 (6), S2 (6), S3 (10)	P1.5 (5), P2 (8), P3 (10), E2 (6), E3 (8), Z1.5 (5), T2.5 (6), S2 (6), S3 (10)
<b>S</b>	P1.5 (5), P2 (8), P3 (10 *), T2.5 (6)	P1.5 (5), P2 (8), P3 (10), Z1.5 (5), T2.5 (6)

(\*) UP TO 16 m FOR TWO SEALS WITH SILICONE OIL DC200 FILLING

## Operative limits

### Temperature limits °C (°F) :

#### Ambient (is the operating temperature)

Lower limit: -40°C (-40°F) for sensor codes E to S;  
-25°C (-13°F) for sensor code B;  
-20°C (-4°F) for LCD indicator

Upper limit: +85°C (+185°F);  
+70°C (+158°F) for LCD indicator

Note : For Hazardous Atmosphere applications see the temperature range specified on the certificate/approval relevant to the aimed type of protection

#### Process

Lower limit (side without seal for 364DR only)

- refer to lower ambient limits;

Upper limit (side without seal for 364DR only)

- Silicone oil: 121°C (250°F)

100°C (212°F) for application below atmospheric pressure

The following table show characteristics of capillary/seal fill fluids when used in transmitters with remote seal.

FILL FLUIDS (APPLICATION)	OPERATING CONDITIONS			
	Tmax @ Pabs>of	Pmin mbar abs (psia)	Tmax @ P min	Tmin
Silicone oil-DC200 (General purpose)	200 (390) @ 35mbar	0.7 (0.01)	160 (320)	-40 (-40)
Silicone oil-DC704 (High temperature)	375 (707) @ 1bar	0.7 (0.01)	220 (428)	-10 (+14)
Silicone Polymer-SylthermXLT (Low temperature)	100 (212) @ 110mbar	2 (0.03)	20 (68)	-100 (-148)
Vegetable oil-Neobee M-20 (Food-Sanitary) FDA	200 (390) @ 1bar	130 (1.9)	150 (300)	-18 (0)
Glycerin Water (70%) (Food-Sanitary) FDA	93 (200) @ 1bar	1000 (14.5)	93 (200)	-7 (+20)
Mineral oil-MARCOL 82 (Food-Sanitary) FDA	200 (390) @ 200mbar	33 (0.5)	40 (104)	-40 (-40)
Inert - Galden (Oxygen Service)	160 (320) @ 1bar	2 (0.03)	70 (158)	-20 (-4)
Inert - Halocarbon 4.2 (Oxygen Service)	180 (356) @ 400mbar	4 (0.06)	70 (158)	-20 (-4)

Fill fluids with FDA are defined as food fills and are Generally Recognized As Safe (GRAS) by the US Food and Drug Administration (FDA).

REFER ALSO TO S364 DATA SHEET FOR FURTHER LIMITATION DUE TO SEAL VARIANTS.

#### Storage

Lower limit: -50°C (-58°F); -40°C (-40°F) for LCD indicators

Upper limit: +85°C (+185°F)

## Pressure limits

Refer to S364 seal data sheet for maximum working pressure related to the used remote seal.

#### Overpressure limits (without damage to the transmitter)

0.07kPa abs, 0.7mbar abs, 0.01psia to transmitter sensor limit or flange/fitting rating of seal, whichever is less:

- 20MPa, 200bar, 2900psi for sensor codes G to S of models 364DR and 364PR

- 7MPa, 70bar, 1015psi for sensor code B of model 364DR

- 16MPa, 160bar, 2320psi for sensor code E of models 364DR and 364PR.

#### Static pressure

Transmitters for differential pressure model 364DR operates within specifications between the following limits:

- 1.3kPa abs, 13mbar abs, 0.2psia and 20MPa, 200bar, 2900psi (7MPa, 70bar, 1015psi for sensor code B and 16MPa, 160bar, 2320psi for sensor code E), or flange/fitting rating of seal whichever is less, using one remote seal and one threaded process connection

- 0.07kPa abs, 0.7mbar abs, 0.1psia and 20MPa, 200bar, 2900psi (7MPa, 70bar, 1015psi for sensor code B and 16MPa, 160bar, 2320 psi for sensor code E) or flange/fitting rating of seal whichever is less, using two remote seals on both transmitter side.

#### Proof pressure

The transmitter can be exposed without leaking to line pressure of up to 38.5MPa, 385bar, 5585psi or two times the flange/fitting rating of seal, whichever is less. Meet ANSI/ISA-S 82.03 hydrostatic test requirements and SAMA PMC 27.1.

## Environmental limits

### Electromagnetic compatibility (EMC)

Comply with EN 61000–3 for emission and EN 61000–6–2 for immunity requirements and test;

Radiated electromagnetic immunity level: 10V/m  
(according to IEC 1000–4–3, EN61000–4–3)

Conducted electromagnetic immunity level : 10V  
(according to IEC 1000–4–6, EN 61000–4–6)

Surge immunity level: 4kV  
(according to IEC 1000–4–5 EN 61000–4–5)

Fast transient (Burst) immunity level: 4kV  
(according to IEC 1000–4–4 EN 61000–4–4)

### Humidity

Relative humidity: up to 100% annual average

Condensing, icing: admissible

### Vibration resistance

Accelerations up to 2g at frequency up to 1000Hz  
(according to IEC 60068–2–6)

### Shock resistance

Acceleration: 50g

Duration: 11ms

(according to IEC 60068–2–27)

### Wet and dust-laden atmospheres

The transmitter is dust and sand tight and protected against immersion effects as defined by EN 60529 (1989) to IP 67 or by NEMA to 4X.

### Hazardous atmospheres

With or without integral display

ATEX/ZELM approval

INTRINSIC SAFETY (Category 1): (code E1)

II 1 GD T50°C, EEx ia IIC T6 (–50°C ≤ Ta ≤ +40°C) respectively

II 1 GD T95°C, EEx ia IIC T4 (–50°C ≤ Ta ≤ +85°C) or

II 1/2 GD T50°C, EEx ia IIC T6 (–50°C ≤ Ta ≤ +40°C) respectively

II 1/2 GD T95°C, EEx ia IIC T4 (–50°C ≤ Ta ≤ +85°C)

EXPLOSION PROOF (Category 2): (code E2)

II 1/2 GD T50°C, EEx d IIC T6 IP67 T85°C (–50°C ≤ Ta ≤ +75°C)

TYPE "N" (Category 3): (included in code EW with E1 and E2)

II 3 GD T50°C, EEx nL IIC T6 IP67 (–50°C ≤ Ta ≤ +40°C) or

II 3 GD T95°C, EEx nL IIC T4 IP67 (–50°C ≤ Ta ≤ +85°C)

CANADIAN STANDARDS ASSOCIATION (code E4)

FACTORY MUTUAL (code E6)

– Explosionproof: Class I, Div. 1, Groups A, B, C, D

– Dust ignitionproof : Class II, Div. 1, Groups E, F, G

– Suitable for : Class II, Div. 2, Groups F, G; Class III, Div. 1, 2

– Nonincendive: Class I, Div. 2, Groups A, B, C, D

– Intrinsically safe: Class I, II, III, Div. 1, Groups A, B, C, D, E, F, G  
AEx ia IIC T6/T4, Zone 0 (FM)

COMBINED ATEX, FM and CSA (code EN)

combination of E1, E2, E4 and E6

COMBINED ATEX (code E7)

combination of E1 and E2

COMBINED NEPSI (code EP)

NEPSI approval

INTRINSIC SAFETY/CHINA:

Ex ia IIC T4-T6

FLAMEPROOF/CHINA:

Ex d IIC T6

TYPE "N"/CHINA

EEx nL IIC T4-T6

GOST (Russia) and GOST (Kazakhstan) based on ATEX

## Electrical Characteristics and Options

### HART digital communication and 4 to 20mA output

#### Power Supply

The transmitter operates from 10.5 to 42VDC with no load and is protected against reverse polarity connection (additional load allows operations over 42VDC).

For EEx ia and other intrinsically safe approval power supply must not exceed 30VDC.

Minimum operating voltage is 15.3VDC if on terminals for external meter neither link nor remote indicator is present.

#### Ripple

20mV max on a 250Ω load as per HART specifications

#### Load limitations

4 to 20mA and HART total loop resistance :

$$R(k\Omega) = \frac{\text{Supply voltage} - \text{min. operating voltage (VDC)}}{22.5}$$

A minimum of 250Ω is required for HART communication.

## Optional indicators

### Integral display

Wide screen LCD, 128 x 64 pixel,  
52.5 x 27.2mm (2.06 x 1.07in) dot matrix.

Four keys for configuration and management of device.

Easy setup for quick commissioning.

User selectable application-specific visualizations.

Totalized and instantaneous flow indication.

Display also indicates in/out transfer function, static pressure, sensor temperature and diagnostic messages and provides configuration facilities.

### Output signal

Two-wire 4 to 20mA, user-selectable for linear or square root output, power of  $3/2$  or  $5/2$ , 5th order or two 2nd order switching point selectable programmable polynomial output.

Low flow cut-off facility.

HART® communication provides digital process variable (% , mA or engineering units) superimposed on 4 to 20mA signal, with protocol based on Bell 202 FSK standard.

### Output current limits (to NAMUR standard)

Low saturation: 3.8mA (field configurable from 3.7 to 4mA)

High saturation: 20.5mA (field configurable from 20 to 22.5mA)

### Alarm current

Low alarm current: 3.7mA (field configurable from 3.7 to 4mA)

High alarm current: 22mA (field configurable from 20 to 22.5mA)

Factory setting: high alarm current

## Performance specifications

Stated at reference condition to IEC 60770 ambient temperature of 20°C (68°F), relative humidity of 65%, atmospheric pressure of 1013hPa (1013mbar), mounting position with vertical diaphragm and zero based range for transmitter with isolating diaphragms in Hastelloy and silicone oil fill and digital trim values equal to span end points, in linear mode.

Unless otherwise specified, errors are quoted as % of span.

Some performance data are affected by the actual turndown (TD) as ratio between Upper Range Limit (URL) and calibrated span.

IT IS RECOMMENDED TO SELECT THE TRANSMITTER SENSOR CODE PROVIDING THE TURNDOWN VALUE AS LOWEST AS POSSIBLE TO OPTIMIZE PERFORMANCE CHARACTERISTICS.

## Accuracy rating

% of calibrated span, including combined effects of terminal based linearity, hysteresis and repeatability.

Using remote seal sizes <DN 80/3in

- ±0.085% for TD from 1:1 to 10:1  
(±0.10% for sensor codes Q and S for TD from 1:1 to 10:1;  
±0.10% for sensor codes B and E for TD from 1:1 to 5:1)

$$- \pm 0.0085\% \times \frac{\text{URL}}{\text{Span}} \text{ for TD from 10:1 to 20:1}$$

$$(\pm 0.01\% \times \frac{\text{URL}}{\text{Span}} \text{ for sensor codes Q and S for TD from 10:1 to 20:1;} \\ \pm 0.02\% \times \frac{\text{URL}}{\text{Span}} \text{ for sensor codes B and E for TD from 5:1 to 10:1)}$$

Using remote seal sizes ≥ DN 80/3in

- ±0.06% for TD from 1:1 to 10:1  
( ±0.075% for sensor codes B and E for TD from 1:1 to 5:1 and  
for sensor codes Q and S for TD from 1:1 to 10:1)

$$- \pm 0.006\% \times \frac{\text{URL}}{\text{Span}} \text{ for TD from 10:1 to 20:1}$$

$$(\pm 0.015\% \times \frac{\text{URL}}{\text{Span}} \text{ for sensor codes B and E for TD from 5:1 to 10:1;} \\ \pm 0.0075\% \times \frac{\text{URL}}{\text{Span}} \text{ for sensor codes Q and S for TD from 10:1 to 20:1)}$$

Multiply the values by 1.5 for sensor/seal combination marked (●)

## Operating influences

### Ambient temperature

per 20K (36 °F) ambient temperature change on transmitter sensor between the limits of -20°C to +65°C (-4 to +150°F):

Sensor Code	for TD	
E to S	15:1	± (0.02% URL + 0.026% span)
B	10:1	± (0.04% URL + 0.05% span)

but not greater than total ± 0.10% of URL for sensor codes E to S from -40°C to +85°C.

The total temperature error is the combination of the above transmitter effect with seal errors, as applicable due to application temperatures.

Refer to seal data sheet for additional effects of the remote seal.

### Static pressure (zero errors can be calibrated out at line pressure)

for differential measurement per 2MPa, 20bar or 290psi.

#### Model 364DR with remote seal(s)

- zero error: ±0.25% of URL
- span error: ±0.25% of reading

Multiply by 1.5 the errors for sensor codes B and E and for sensor/seal combinations marked (●)

### Supply voltage

Within voltage/load specified limits the total effect is less than 0.005% of URL per volt.

### Load

Within load/voltage specified limits the total effect is negligible.

### Electromagnetic field

Total effect : less than 0.06% of span from 80 to 1000MHz and for field strengths up to 10V/m when tested with unshielded conduit and grounding, with or without meter.

### Common mode interference

No effect from 100Vrms @ 50Hz, or 50VDC

### Mounting position

Rotations in plane of diaphragm have negligible effect. A tilt to 90° from vertical causes a zero shifts up to 0.6kPa, 6mbar or 2.4inH2O, which can be corrected with the zero adjustment. No span effect.

### Vibration effect

±0.10% of URL (according to IEC 61298-3)

## Physical Specification

(Refer to ordering information sheets of transmitter and seal(s) for variant availability related to specific model or versions code)

### Materials

#### Model 364DR only – Side without seal

##### Process isolating diaphragms (\*)

Hastelloy C276™ on AISI 316 L ss seat.

A remote seal can be selected with required diaphragm (refer below)

##### Process connection, adapters, plugs and drain/vent valves (\*)

AISI 316 L ss (NACE)

##### Bolts (for adapter only if selected)

AISI 316 ss bolts Class A4–50 per UNI 7323 (ISO 3506), in compliance with NACE MR0175 Class II.

##### Gasket (for adapter only, if selected) (\*)

PTFE.

#### Models 364DR/PR

##### Blind (reference with filter) or threaded process connection

AISI 316 L ss

##### Seal side process diaphragm (remote seal) (\*)

AISI 316 L ss; Hastelloy C276™; Hastelloy C2000™; Inconel 625; Tantalum; AISI 316 L ss or Hastelloy C276™ with anti-stick coating; AISI 316 L ss with anti-corrosion coating; AISI 316 L ss gold plated; Superduplex ss (UNS S32750 to ASTM SA479); Diaflex (AISI with anti-abrasion treatment).

##### Extension material

AISI 316 L ss (also for Diaflex and gold plated diaphragms); Hastelloy C276™; AISI 316 L ss or Hastelloy C276™ with coating same as diaphragm

##### Seal side fill fluid (remote seal)

Silicone oil-DC200™, Silicone oil-DC704™, Inert-Halocarbon™4.2, Inert-Galden™, Silicone Polymer-Syltherm XTL™, Vegetable oil-Neobee M-20™, Glycerin Water, Mineral oil-MARCOL 82™.

##### Sensor fill fluid

Silicone oil (DC200™).

##### Electronic/sensor housing and cover

AISI 304 ss, AISI 316 L ss.

##### Covers O-ring

Buna N.

##### Mounting bracket (\*\*)

AISI 304 ss, AISI 316 L ss

##### Tagging

AISI 316ss data/certification plate welded to the electronics housing.

### Calibration

Standard: at maximum span, zero based range, P2=HIGH, P1=LOW, at ambient temperature and pressure;

Optional: at specified range and ambient conditions.

### Optional extras

#### Mounting brackets

For vertical and horizontal 60mm. (2in) pipes or wall mounting.

#### Display

4-position (at 90°) user rotatable

#### Additional customer plate (option code I2)

AISI 316 ss plate wired-on to the transmitter for customer data up to a maximum of 32 characters and spaces per four lines for customizable details.

#### Test Certificates (test, design, calibration, material traceability)

#### Tag and manual language

#### Electrical connection metal plug

One stainless steel IP67 plug can be supplied on request, replacing one of the temporary plastic plug.

#### Process connections

on threaded connection : 1/4 – 18 NPT on process axis

on adapters : 1/2 – 14 NPT on process axis or 1/4 – 18 NPT or 1/2 – 14 NPT side entry

fixing threads: 7/16 – 20 UNF at 41.3mm centre distance

Refer to seal data sheet for process connection variants through remote seal.

#### Electrical connections

Two 1/2 – 14 NPT or M20x1.5 threaded conduit entries, direct on housing.

#### Terminal block

Three terminals for signal/external meter wiring up to 2.5mm<sup>2</sup> (14AWG)

#### Grounding

Internal and external 6mm<sup>2</sup> (10AWG) ground termination points are provided.

#### Mounting position

Transmitter can be mounted in any position.

#### Mass (without options and seals)

3.2kg approx (7lb)  
Add 650g (1.5lb) for packing.

#### Packing

Carton

(\*) Wetted parts of the transmitter

(\*\*) U-bolt material: AISI 400 ss;  
screws material: high-strength alloy steel or AISI 316 ss.

## Configuration

### Transmitter with HART communication and 4 to 20 mA

#### Standard configuration

Transmitters are factory calibrated from 0 to +URL. If required calibrated range and tag number are stamped on the tag plate. If a calibration range and tag data are not specified, the transmitter will be supplied with the plate left blank and configured as follows:

Pressure polarity	P2 set as high pressure side
Engineering Unit	kPa
4 mA	Zero
20 mA	Upper Range Limit (URL)
Output	Linear
Damping	1 sec.
Transmitter failure mode	Upscale
Software tag characters	Blank
Optional LCD integral display	Input pressure (linear) in calibration engineering unit plus analog output after transfer function in percentage on bargraph

Any or all the above configurable parameters, including Lower range-value and Upper range-value which must be the same unit of measure, can be easily changed using the HART hand-held communicator or by a PC running the configuration software SMART VISION with DTM for 2600T. The transmitter database is customized with specified flange type and material, O-ring and drain/vent materials and meter code option. Custom configuration (option).

The following data may be specified in addition to the standard configuration parameters:

Descriptor	16 alphanumeric characters
Message	32 alphanumeric characters
Date	Day, month, year

## Electrical connections

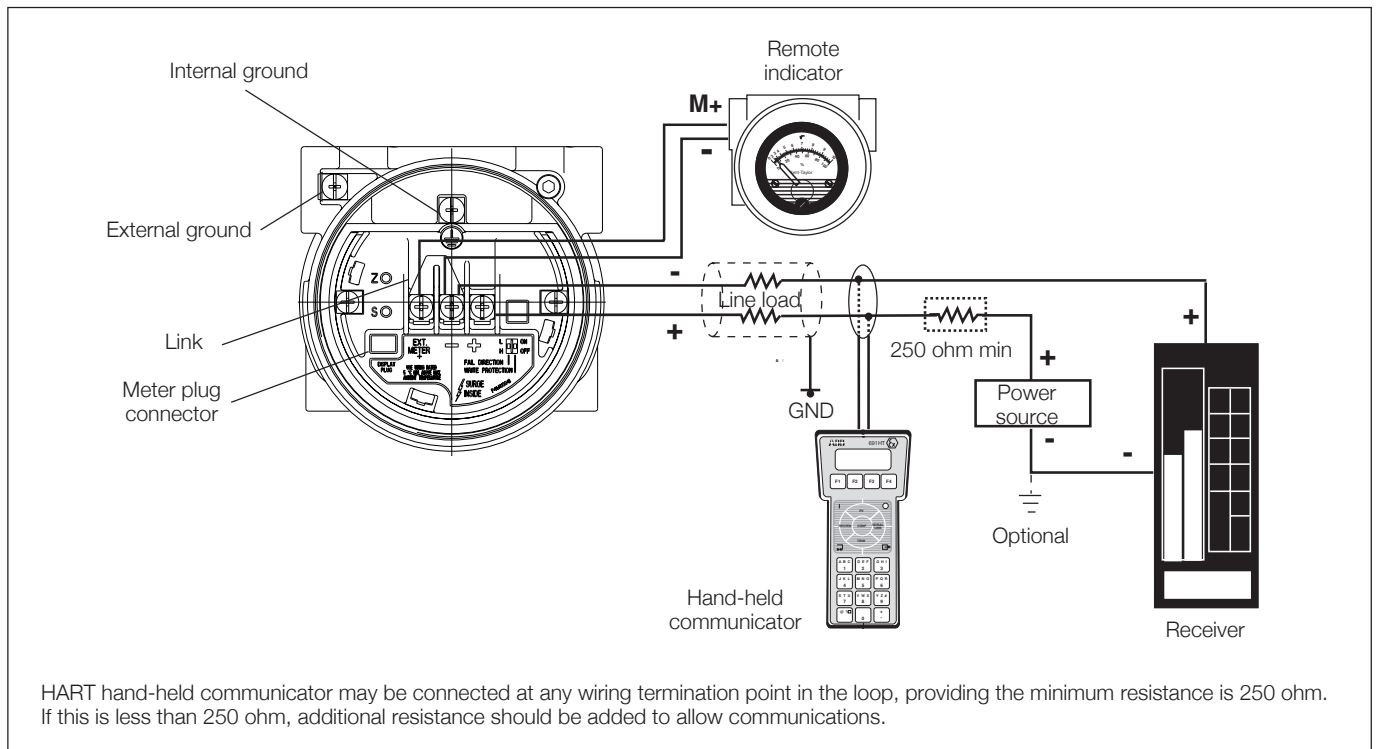

**MOUNTING DIMENSIONS** (not for construction unless certified) – dimensions in mm (in)

NOTE: For 364DR, 1/4 – 18 NPT direct threaded connection, gasket groove and gaskets are in accordance with IEC 61518. Bolting threads for fixing adapter or other devices on process connection is 7/16 – 20 UNF.

**364DR transmitter with two capillaries for remote seals**

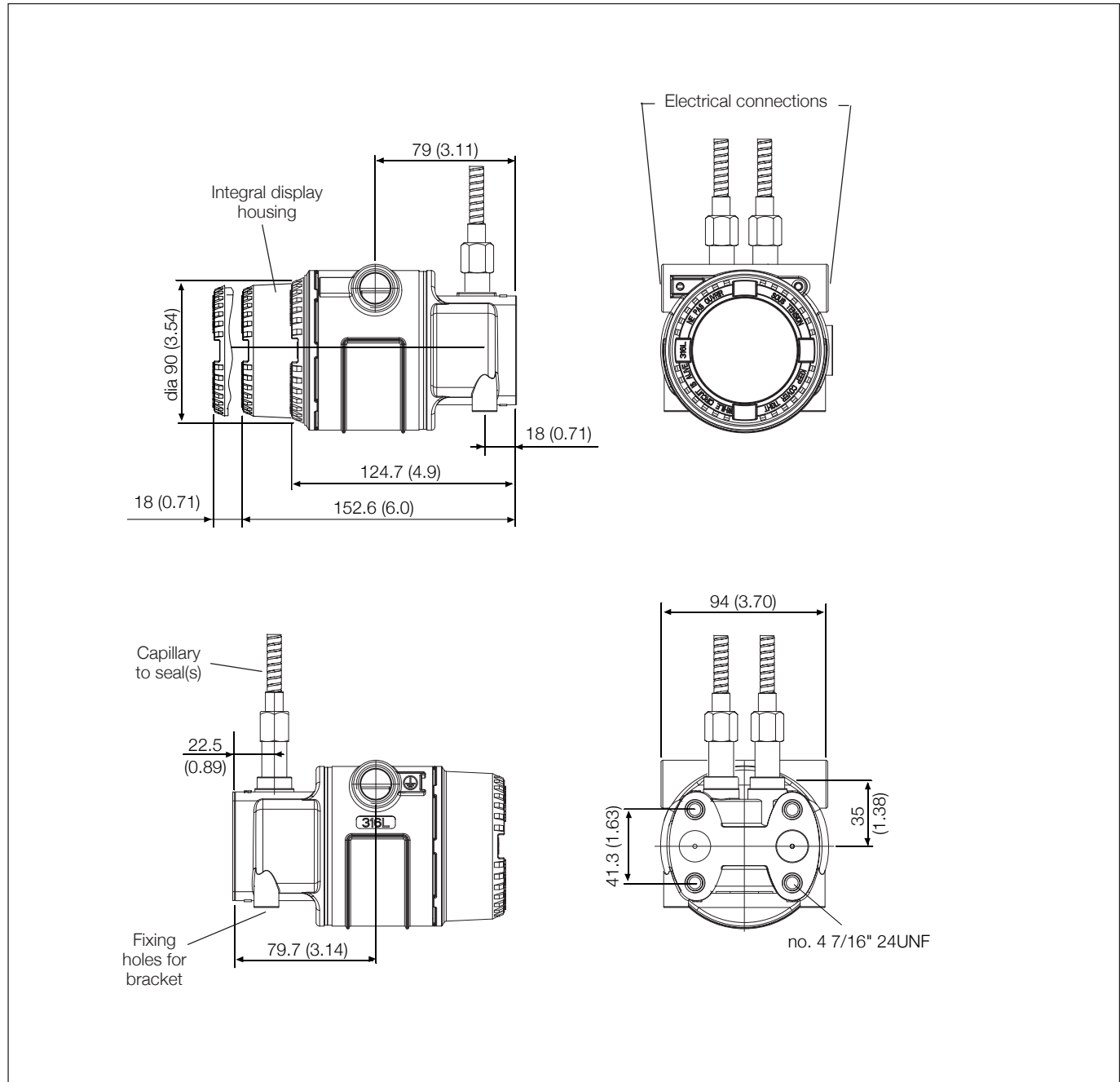

**364DR transmitter with one capillary for remote seal and one threaded side entry connection on compact wall (pipe) mounting bracket**

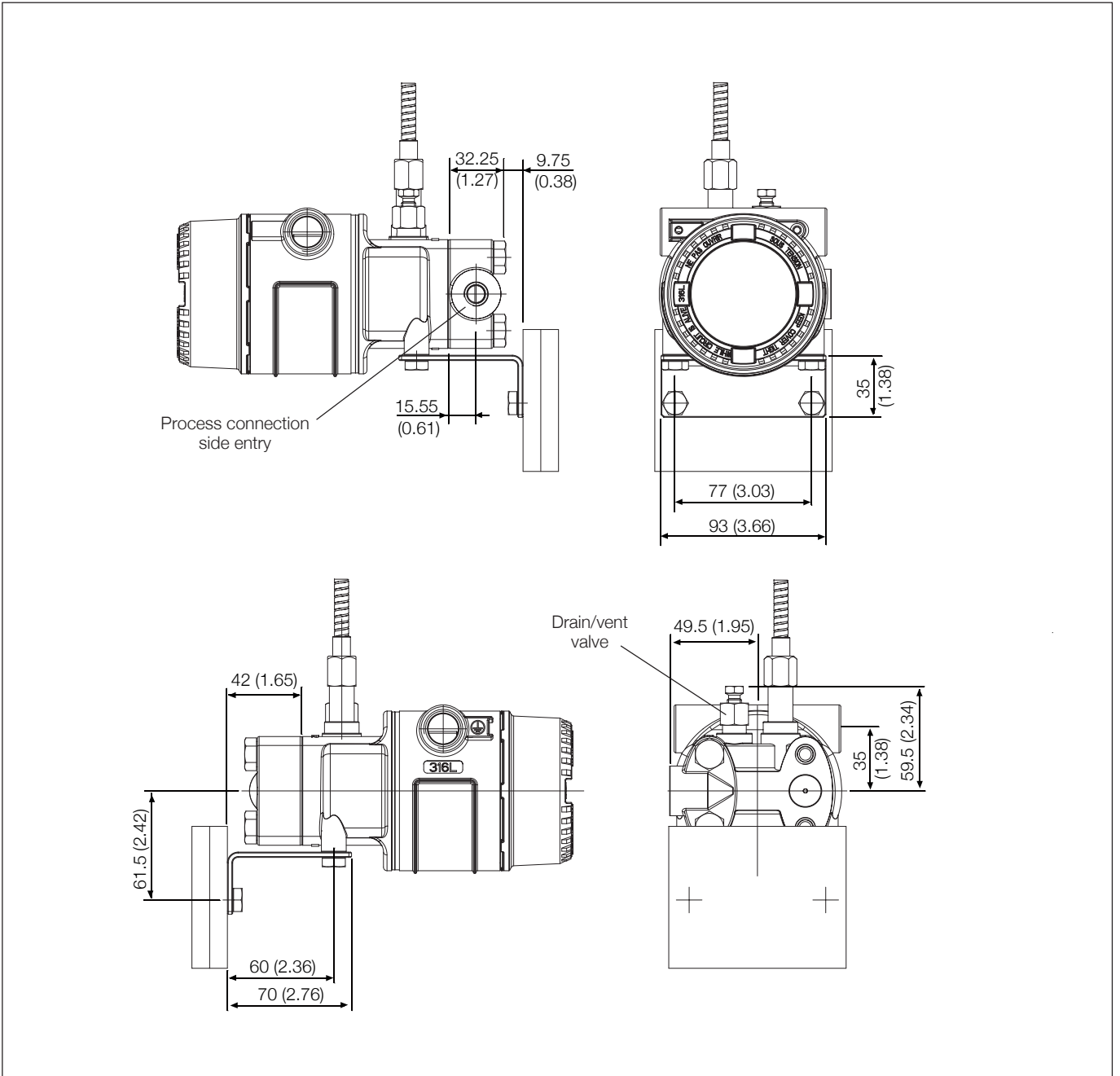

Transmitter with bracket on horizontal pipe (mounting examples)

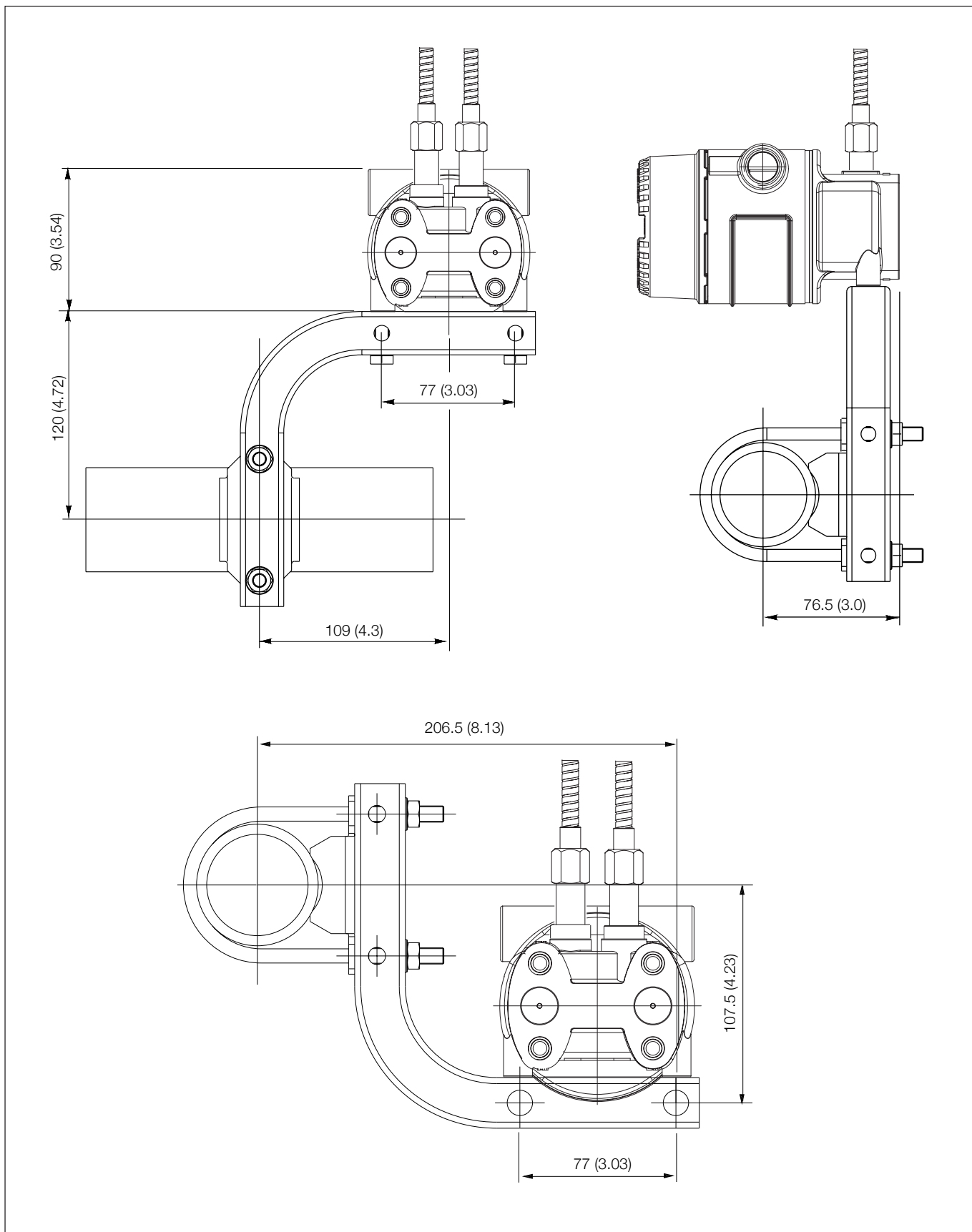

**BASIC ORDERING INFORMATION model 364DR Differential Pressure Transmitters with remote seal(s)**

Select one character or set of characters from each category and specify complete catalog number. Refer to additional ordering information code and specify one or more codes for each transmitter if additional options are required.

<b>BASE MODEL</b> – 1 <sup>st</sup> to 5 <sup>th</sup> characters			X	S	X	X	0	X	X
Differential Pressure Transmitter with remote seal(s) – BASE ACCURACY 0.06%			3	6	4	D	R		
<b>SENSOR - Span limits</b> – 6 <sup>th</sup> character									
0.2 and 4kPa	2 and 40mbar	0.8 and 16inH <sub>2</sub> O	B						
0.54 and 16kPa	5.4 and 160mbar	2.14 and 64inH <sub>2</sub> O	E						
1.1 and 65kPa	11 and 650mbar	4.35 and 260inH <sub>2</sub> O	G						
2.67 and 160kPa	26.7 and 1600mbar	10.7 and 642inH <sub>2</sub> O	H						
10 and 600kPa	0.1 and 6bar	1.45 and 87psi	M						
40 and 2400kPa	0.4 and 24bar	5.8 and 348psi	P						
134 and 8000kPa	1.34 and 80bar	19.4 and 1160psi	Q						
267 and 16000kPa	2.67 and 160bar	38.7 and 2320psi	S						
<b>Use code</b> – 7 <sup>th</sup> character								S	
<b>Diaphragm material / Fill fluid (wetted parts)</b> – 8 <sup>th</sup> character									
Hastelloy C276™ on AISI seat		Silicone oil (one remote seal to be quoted separately) - (NACE)						H	
Hastelloy C276™ on AISI seat		Silicone oil (NOT WETTED) - (two remote seals to be quoted separately)						R	
<b>Process connection material and connection (wetted parts)</b> – 9 <sup>th</sup> character									
AISI 316 L ss for two seals construction - NOT WETTED							(Note 1)	R	
AISI 316 L ss 1/4 - 18 NPT-f direct - (low pressure connection provided with drain/vent valve)							(Note 2)	2	
AISI 316 L ss 1/2 - 14 NPT-f / through adapter - low pressure connection provided with drain/vent valve)							(Note 2)	3	
AISI 316 L ss 1/4 - 18 NPT-f / through adapter - SIDE ENTRY (low pressure connection provided with drain/vent valve)							(Note 2)	4	
AISI 316 L ss 1/2 - 14 NPT-f / through adapter - SIDE ENTRY (low pressure connection provided with drain/vent valve)							(Note 2)	5	
<b>Bolts/Gasket for adapters (wetted parts)</b> – 10 <sup>th</sup> character									
None for PROCESS CONNECTION code R or 2								0	
AISI 316 ss (NACE) / PTFE for PROCESS CONNECTION code 3, 4 or 5									
<b>Housing material and electrical connection</b> – 11 <sup>th</sup> character									
AISI 304 ss		1/2 – 14 NPT							S
AISI 304 ss		M20 x 1.5 (CM20)							T
AISI 316 L ss		1/2 – 14 NPT							3
AISI 316 L ss		M20 x 1.5 (CM20)							4
<b>Output/Additional options</b> – 12 <sup>th</sup> character									
HART digital communication and 4 to 20mA		No additional options							H
HART digital communication and 4 to 20mA		Options requested (to be ordered by "Additional ordering code")							1

**ADDITIONAL ORDERING INFORMATION for model 364DR**

Add one or more 2-digit code(s) after the basic ordering information to select all required options

	XX	XX	XX	XX	XX	XX	XX	XX	XX	XX	XX
<b>Electrical certification</b>											
Combined ATEX (EEx ia and EEx d) plus FM plus CSA	EN										
Combined ATEX - Intrinsic Safety and Flameproof	E7										
Combined ATEX - Intrinsic Safety, Flameproof and Type "N"	EW										
Combined NEPSI - Intrinsic Safety, Flameproof and Type "N"	EP										
ATEX Group II Category 1 GD - Intrinsic Safety EEx ia	E1										
ATEX Group II Category 1/2 GD - Flameproof EEx d	E2										
Canadian Standard Association (CSA)	E4										
Factory Mutual (FM) approval	E6										
GOST (Russia) EEx ia	W1										
GOST (Russia) EEx d	W2										
GOST (Kazakhstan) EEx ia	W3										
GOST (Kazakhstan) EEx d	W4										
<b>Integral LCD</b>											
Digital LCD integral display	L1										
<b>Mounting bracket</b>											
AISI 304 ss for pipe mounting										B2	
AISI 304 ss for wall mounting										B4	
AISI 316 L ss for pipe mounting										B8	
AISI 316 L ss for wall mounting										B9	
AISI 316 L ss for compact wall/pipe mounting										BA	
<b>Operating manual</b>											
German										M1	
Italian										M2	
<b>Labels &amp; tag language</b>											
German										T1	
Italian										T2	
<b>Additional customer plate</b>											
Laser printing of customer data on wired-on stainless steel plate										I2	
<b>Configuration</b>											
Standard – Pressure = inH <sub>2</sub> O/psi at 20° C; Temperature = deg. F										N2	
Standard – Pressure = inH <sub>2</sub> O/psi at 4° C; Temperature = deg. F										N3	
Standard – Pressure = inH <sub>2</sub> O/psi at 20° C; Temperature = deg.C										N4	
Standard – Pressure = inH <sub>2</sub> O/psi at 4° C; Temperature = deg. C										N5	
Custom										N6	
<b>Certificates</b>											
Inspection certificate EN 10204-3.1 of calibration (9-point)										C1	
Certificate of compliance with the order EN 10204-2.1 of instrument design										C6	
<b>Approvals</b>											
Det Norske Veritas naval approval										C7	
Bureau Veritas naval approval										CV	
<b>Material traceability</b>											
Certificate of compliance with the order EN 10204-2.1 of process wetted parts										H1	
Inspection certificate EN 10204-3.1 of process wetted parts										H3	
<b>Electrical connection plug</b>											
Stainless steel blind plug (General purpose only)										Z1	
Stainless steel blind plug (EEx d)										Z2	

Note 1: Not available with Diaphragm material / Fill fluid code H

Note 2: Not available with Diaphragm material / Fill fluid code R

**Standard delivery items (can be differently specified by additional ordering code)**

- Adapters supplied loose
- General purpose (no electrical certification)
- Temporary plastic electrical connection blind plugs (two no Ex)
- No display, no mounting bracket
- English manual and labels
- Configuration with kPa and deg. C units
- No test, inspection or material traceability certificates

THE SELECTION OF SUITABLE WETTED PARTS AND FILLING FLUID FOR COMPATIBILITY WITH THE PROCESS MEDIA IS A CUSTOMER'S RESPONSIBILITY, IF NOT OTHERWISE NOTIFIED BEFORE MANUFACTURING.

**BASIC ORDERING INFORMATION model 364PR Gauge Pressure Transmitters with remote seal**

Select one character or set of characters from each category and specify complete catalog number.

Refer to additional ordering information code and specify one or more codes for each transmitter if additional options are required.

<b>BASE MODEL</b> – 1 <sup>st</sup> to 5 <sup>th</sup> characters			<b>X</b>	<b>S</b>	<b>X</b>	<b>X</b>	<b>0</b>	<b>X</b>	<b>X</b>
Gauge Pressure Transmitter with remote seal – BASE ACCURACY 0.06%			<b>3</b>	<b>6</b>	<b>4</b>	<b>P</b>	<b>R</b>		
<b>SENSOR - Span limits</b> – 6 <sup>th</sup> character									
0.54 and 16kPa	5.4 and 160mbar	2.14 and 64inH <sub>2</sub> O		E					
1.1 and 65kPa	11 and 650mbar	4.35 and 260inH <sub>2</sub> O		G					
2.67 and 160kPa	26.7 and 1600mbar	10.7 and 642inH <sub>2</sub> O		H					
10 and 600kPa	0.1 and 6bar	1.45 and 87psi		M					
40 and 2400kPa	0.4 and 24bar	5.8 and 348psi		P					
134 and 8000kPa	1.34 and 80bar	19.4 and 1160psi		Q					
267 and 16000kPa	2.67 and 160bar	38.7 and 2320psi		S					
<b>Use code</b> – 7 <sup>th</sup> character									S
<b>Diaphragm material / Fill fluid</b> – 8 <sup>th</sup> character									
Hastelloy C276™ on AISI seat		Silicone oil (one seal to be quoted separately)							R
<b>Process connection material</b> – 9 <sup>th</sup> character									
AISI 316 L ss for seal construction with negative side provided of filter and plug									R
<b>Bolts/Gasket</b> – 10 <sup>th</sup> character									
None									0
<b>Housing material and electrical connection</b> – 11 <sup>th</sup> character									
AISI 304 ss		1/2 – 14 NPT							S
AISI 304 ss		M20 x 1.5 (CM20)							T
AISI 316 L ss		1/2 – 14 NPT							3
AISI 316 L ss		M20 x 1.5 (CM20)							4
<b>Output/Additional options</b> – 12 <sup>th</sup> character									
HART digital communication and 4 to 20mA		No additional options							H
HART digital communication and 4 to 20mA		Options requested (to be ordered by "Additional ordering code")							1

**ADDITIONAL ORDERING INFORMATION for models 364PR**

Add one or more 2-digit code(s) after the basic ordering information to select all required options

	XX	XX	XX	XX	XX	XX	XX	XX	XX	XX	XX
<b>Electrical certification</b>											
Combined ATEX (EEx ia and EEx d) plus FM plus CSA	EN										
Combined ATEX - Intrinsic Safety and Flameproof	E7										
Combined ATEX - Intrinsic Safety, Flameproof and Type "N"	EW										
Combined NEPSI - Intrinsic Safety, Flameproof and Type "N"	EP										
ATEX Group II Category 1 GD - Intrinsic Safety EEx ia	E1										
ATEX Group II Category 1/2 GD - Flameproof EEx d	E2										
Canadian Standard Association (CSA)	E4										
Factory Mutual (FM) approval	E6										
GOST (Russia) EEx ia	W1										
GOST (Russia) EEx d	W2										
GOST (Kazakhstan) EEx ia	W3										
GOST (Kazakhstan) EEx d	W4										
<b>Integral LCD</b>											
Digital LCD integral display	L1										
<b>Mounting bracket</b>											
AISI 304 ss for pipe mounting										B2	
AISI 304 ss for wall mounting										B4	
AISI 316 L ss for pipe mounting										B8	
AISI 316 L ss for wall mounting										B9	
AISI 316 L ss for compact wall/pipe mounting										BA	
<b>Operating manual</b>											
German										M1	
Italian										M2	
<b>Labels &amp; tag language</b>											
German										T1	
Italian										T2	
<b>Additional customer plate</b>											
Laser printing of customer data on wired-on stainless steel plate										I2	
<b>Configuration</b>											
Standard – Pressure = inH <sub>2</sub> O/psi at 20° C; Temperature = deg. F										N2	
Standard – Pressure = inH <sub>2</sub> O/psi at 4° C; Temperature = deg. F										N3	
Standard – Pressure = inH <sub>2</sub> O/psi at 20° C; Temperature = deg.C										N4	
Standard – Pressure = inH <sub>2</sub> O/psi at 4° C; Temperature = deg. C										N5	
Custom										N6	
<b>Certificates</b>											
Inspection certificate EN 10204-3.1 of calibration (9-point)										C1	
Certificate of compliance with the order EN 10204-2.1 of instrument design										C6	
<b>Approvals</b>											
Det Norske Veritas naval approval										C7	
Bureau Veritas naval approval										CV	
<b>Material traceability</b>											
Certificate of compliance with the order EN 10204-2.1 of process wetted parts										H1	
Inspection certificate EN 10204-3.1 of process wetted parts										H3	
<b>Electrical connection plug</b>											
Stainless steel blind plug (General purpose only)										Z1	
Stainless steel blind plug (EEx d)										Z2	

**Standard delivery items (can be differently specified by additional ordering code)**

- Adapters supplied loose
- General purpose (no electrical certification)
- Temporary plastic electrical connection blind plugs (two no Ex)
- No display, no mounting bracket
- English manual and labels
- Configuration with kPa and deg. C units
- No test, inspection or material traceability certificates

THE SELECTION OF SUITABLE WETTED PARTS AND FILLING FLUID FOR COMPATIBILITY WITH THE PROCESS MEDIA IS A CUSTOMER'S RESPONSIBILITY, IF NOT OTHERWISE NOTIFIED BEFORE MANUFACTURING.



# Contact us

## **ABB Ltd.**

### **Process Automation**

Howard Road  
St. Neots  
Cambridgeshire PE19 8EU  
UK  
Tel: +44 (0)1480 475321  
Fax: +44 (0)1480 217948

## **ABB Inc.**

### **Process Automation**

125 E. County Line Road  
Warminster  
PA 18974  
USA  
Tel: +1 215 674 6000  
Fax: +1 215 674 7183

## **ABB Automation Products GmbH**

### **Process Automation**

Schillerstr. 72  
32425 Minden  
Germany  
Tel: +49 551 905 534  
Fax: +49 551 905 555

## **ABB S.p.A.**

### **Process Automation**

Via Statale 113  
22016 Lenno (CO)  
Italy  
Tel: +39 0344 58111  
Fax: +39 0344 56278

[www.abb.com](http://www.abb.com)

## Note

We reserve the right to make technical changes or modify the contents of this document without prior notice. With regard to purchase orders, the agreed particulars shall prevail. ABB does not accept any responsibility whatsoever for potential errors or possible lack of information in this document.

We reserve all rights in this document and in the subject matter and illustrations contained therein. Any reproduction, disclosure to third parties or utilization of its contents - in whole or in parts - is forbidden without prior written consent of ABB.

Copyright© 2010 ABB  
All rights reserved

™ Hastelloy C276 is a Cabot Corporation trademark

™ Hastelloy C2000 is an Haynes International trademark

™ Monel is an International Nickel Co. trademark

™ Viton is a Dupont de Nemour trademark

™ DC200 and DC704 are Dow Corning Corporation trademarks

™ Galden is a Montefluos trademark

™ Halocarbon is a Halocarbon Products Co. trademark

™ Neobee M20 is a Stepan Company trademark

™ Marcol is a Esso Italiana trademark

™ Syltherm is a Dow Chemical Company trademark