

Model 264HS Gauge Model 264NS Absolute

ABB 2600T Series
Engineered solutions
for all applications



Base accuracy : $\pm 0.075\%$

Span limits

- 0.27 to 60000kPa; 1.08inH₂O to 8700psi
- 1.1 to 16000kPa abs; 8mmHg to 2320psia

Reliable sensing system coupled with very latest digital technologies

- provides large turn down ratio up to 100:1

Comprehensive sensor choice

- optimize in-use total performance and stability

5-year stability

Flexible configuration facilities

- provided locally via local keys combined with LCD indicator or via hand held terminal or PC configuration platform

Multiple protocol availability

- provides integration with HART®, PROFIBUS PA and FOUNDATION Fieldbus platforms offering interchangeability and transmitter upgrade capabilities

Full compliance with PED Category IV

- suitable for safety accessory application

Functional Specifications

Range and span limits

Sensor Code	Upper Range Limit (URL)	Lower Range Limit (LRL) for 264HS	Minimum span	
			264HS gauge	264NS absolute
E	16kPa 160mbar 64inH ₂ O	-16kPa -160mbar -64inH ₂ O	0.27kPa 2.7mbar 1.08inH ₂ O	
G	65kPa 650mbar 260inH ₂ O	-65kPa -650mbar -260inH ₂ O	0.65kPa 6.5mbar 2.6inH ₂ O	1.1kPa 11mbar 8mmHg
H	160kPa 1600mbar 642inH ₂ O	0.07kPa abs (\$) 0.7mbar abs (\$) 0.5mmHg (\$)	1.6kPa 16mbar 6.4inH ₂ O	2.67kPa 26.7mbar 20mmHg
M	600kPa 6bar 87psi	0.07kPa abs (\$) 0.7mbar abs (\$) 0.5mmHg (\$)	6kPa 0.06bar 0.87psi	10kPa 0.1bar 1.45psi
P	2400kPa 24bar 348psi	0.07kPa abs (\$) 0.7mbar abs (\$) 0.5mmHg (\$)	24kPa 0.24bar 3.5psi	40kPa 0.4bar 5.8psi
Q	8000kPa 80bar 1160psi	0.07kPa abs (\$) 0.7mbar abs (\$) 0.5mmHg (\$)	80kPa 0.8bar 11.6psi	134kPa 1.34bar 19.4psi
S	16000kPa 160bar 2320psi	0.07kPa abs (\$) 0.7mbar abs (\$) 0.5mmHg (\$)	160kPa 1.6bar 23.2psi	267kPa 2.67bar 38.7psi
V	60000kPa 600bar 8700psi	0.07kPa abs (\$) 0.7mbar abs (\$) 0.5mmHg (\$)	600kPa 6bar 87psi	

Lower Range Limit (LRL) for 264NS is 0.07kPa abs, 0.7mbar abs, 0.5mmHg for all ranges.

(\$) Lower Range Limit is 0.135kPa abs, 1.35mbar abs, 1mmHg for inert Galden or 0.4kPa abs, 4mbar abs, 3mmHg for inert Halocarbon.

Span limits

Maximum span = URL

IT IS RECOMMENDED TO SELECT THE TRANSMITTER SENSOR CODE PROVIDING THE TURNDOWN VALUE AS LOWEST AS POSSIBLE TO OPTIMIZE PERFORMANCE CHARACTERISTICS.

Zero suppression and elevation

Zero and span can be adjusted to any value within the range limits detailed in the table as long as:

- calibrated span \geq minimum span

Damping

Selectable time constant : 0, 0.25, 0.5, 1, 2, 4, 8 or 16s.
This is in addition to sensor response time

Turn on time

Operation within specification in less than 1s with minimum damping.

Insulation resistance

> 100M Ω at 1000VDC (terminals to earth)

Operative limits

Temperature limits °C (°F) :

Ambient (is the operating temperature)

Filling	Model 264HS		Model 264NS
	Sensors E to S	Sensor V	Sensors G to S
Silicone oil	-40 and +85 (-40 and +185)	-40 and +85 (-40 and +185)	-40 and +85 (-40 and +185)
Inert Galden	-20 and +85 (-4 and +185)		-10 and +65 (+14 and +150)
Inert Halocarbon	-20 and +85 (-4 and +185)		-10 and +65 (+14 and +150)
Inert Carbon Fluoride		-20 and +85 (-4 and +185)	

Lower ambient limit for LCD indicators: -20°C (-4°F)

Upper ambient limit for LCD indicators: +70°C (+158°F)

Note : For Hazardous Atmosphere applications see the temperature range specified on the certificate/approval relevant to the aimed type of protection

Process

Lower limit

- refer to lower ambient limits

Upper limit

- Silicone oil: 121°C (250°F) (1)
 - Inert fluid (Galden or Halocarbon): 100°C (212°F) (2)
 - Inert fluid (Carbon fluoride): 121°C (250°F)
- (1) 100°C (212°F) for application below atmospheric pressure
(2) 65°C (150°F) for application below atmospheric pressure

Storage

Lower limit: -50°C (-58°F); -40°C (-40°F) for LCD indicators

Upper limit: +85°C (+185°F)

Pressure limits

Overpressure limits (without damage to the transmitter)

0.07kPa abs, 0.7mbar abs, 0.01psia (0.135kPa abs, 1.35mbar abs, 1mmHg for inert Galden or 0.4kPa abs, 4mbar abs, 3mmHg for inert Halocarbon) to

- 14MPa, 140bar, 2030psi for sensor codes E, G, H, M
- 21MPa, 210bar, 3045psi for sensor codes P, Q, S
- 90MPa, 900bar, 13050psi for sensor code V

Proof pressure

The transmitter can be exposed without leaking to line pressure of up to

- 28MPa, 280bar, 4060psi for sensor codes E, G, H, M
- 40MPa, 400bar, 5800psi for sensor codes P, Q, S
- 90MPa, 900bar, 13050psi for sensor code V

Meet ANSI/ISA-S 82.03 hydrostatic test requirements and SAMA PMC 27.1.

Environmental limits

Electromagnetic compatibility (EMC)

Comply with EN 61000-6-3 for emission and EN 61000-6-2 for immunity requirements and test;

Radiated electromagnetic immunity level: 30V/m
(according to IEC 1000-4-3, EN61000-4-3)

Conducted electromagnetic immunity level : 30V
(according to IEC 1000-4-6, EN 61000-4-6)

Surge immunity level (with surge protector): 4kV
(according to IEC 1000-4-5 EN 61000-4-5)

Fast transient (Burst) immunity level: 4kV
(according to IEC 1000-4-4 EN 61000-4-4)

Pressure equipment directive (PED)

Comply with 97/23/EEC Category IV Modules D and B.
(Category III Module H for sensor code V).

Humidity

Relative humidity: up to 100% annual average

Condensing, icing: admissible

Vibration resistance

Accelerations up to 2g at frequency up to 1000Hz
(according to IEC 60068-2-6)

Shock resistance

Acceleration: 50g

Duration: 11ms

(according to IEC 60068-2-27)

Wet and dust-laden atmospheres

The transmitter is dust and sand tight and protected against immersion effects as defined by EN 60529 (1989) to IP 67 (IP 68 on request) or by NEMA to 4X or by JIS to C0920. IP65 with Harting Han connector.

Hazardous atmospheres

With or without output meter/integral display

- COMBINED ATEX (Intrinsic safety and flameproof), FM and CSA ZELM approval. See below detailed classifications.
- COMBINED INTRINSIC SAFETY and FLAMEPROOF/EUROPE: ATEX/ZELM approval
 - II 1 GD T50°C, EEx ia IIC T6 (-40°C ≤ Ta ≤ +40°C) T95°C, EEx ia IIC T4 (-40°C ≤ Ta ≤ +85°C)
 - II 1/2 GD T85°C, EEx d IIC T6 (-40°C ≤ Ta ≤ +75°C)
- INTRINSIC SAFETY/EUROPE: ATEX/ZELM approval
 - II 1 GD T50°C, EEx ia IIC T6 (-40°C ≤ Ta ≤ +40°C) T95°C, EEx ia IIC T4 (-40°C ≤ Ta ≤ +85°C)
- TYPE "N"/EUROPE: ATEX/ZELM type examination (for HART)
 - II 3 GD T50°C, EEx nL IIC T6 (-40°C ≤ Ta ≤ +40°C) T95°C, EEx nL IIC T4 (-40°C ≤ Ta ≤ +85°C)
- FLAMEPROOF/EUROPE: ATEX/CESI approval
 - II 1/2 GD T85°C, EEx d IIC T6 (-40°C ≤ Ta ≤ +75°C)
- CANADIAN STANDARDS ASSOCIATION and FACTORY MUTUAL:
 - Explosionproof: Class I, Div. 1, Groups A, B, C, D
 - Dust ignitionproof : Class II, Div. 1, Groups E, F, G
 - Suitable for : Class II, Div. 2, Groups F, G; Class III, Div. 1, 2
 - Nonincendive: Class I, Div. 2, Groups A, B, C, D
 - Intrinsically safe: Class I, II, III, Div. 1, Groups A, B, C, D, E, F, G AEx ia IIC T6/T4, Zone 0 (FM)
- STANDARDS AUSTRALIA (SAA): TS Approval
 - Intrinsically safe Ex ia IIC T4/T5 (-20°C ≤ Ta ≤ +80°C) only HART
 - No sparking Ex n IIC T4/T6 (-20°C ≤ Ta ≤ +80°C) only HART
 - Flameproof Ex d IIC T4/T6 (-20°C ≤ Ta ≤ +80°C)
 - Dust ignitionproof DIP A21 Ta T6 (-20°C ≤ Ta ≤ +80°C)
- INTRINSIC SAFETY/CHINA NEPSI approval Ex ia IIC T4-T6
- FLAMEPROOF/CHINA NEPSI approval Ex d IIC T6
- GOST (Russia), GOST (Kazakhstan), Inmetro (Brazil) based on ATEX

Electrical Characteristics and Options

HART digital communication and 4 to 20mA output

Power Supply

The transmitter operates from 10.5 to 42VDC with no load and is protected against reverse polarity connection (additional load allows operations over 42VDC).

For EEx ia and other intrinsically safe approval power supply must not exceed 30VDC.

Ripple

20mV max on a 250Ω load as per HART specifications

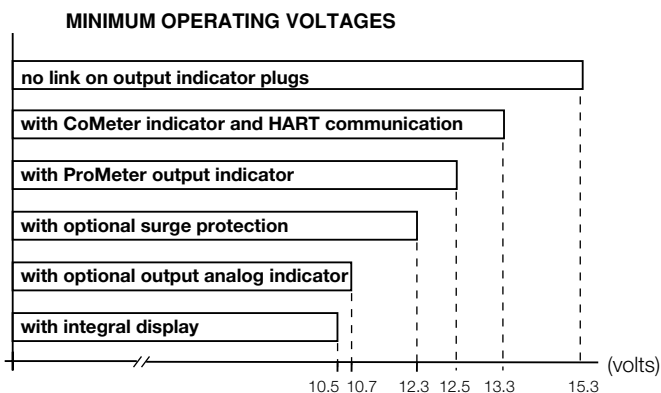

Load limitations

4 to 20mA and HART total loop resistance :

$$R(k\Omega) = \frac{\text{Supply voltage} - \text{min. operating voltage (VDC)}}{22.5}$$

A minimum of 250Ω is required for HART communication.

Optional indicators

Output meter

CoMeter and Prometer LCD :

5-digit (±99999 counts) programmable with 7.6mm. high (3in), 7-segment numeric characters plus sign and digital point for digital indication of output value in percentage, current or engineer unit;

10-segment bargraph display (10% per segment) for analog indication of output in percentage;

7-digit with 6mm. high (2.3in), 14-segment alphanumeric characters, for engineer units and configuration display

Analog : 36mm (1.4in) scale on 90°.

Integral display

LCD, 15 lines x 56 column dot matrix providing 2 lines indication as

– top: 5-digit (numeric) plus sign or 7-digit alphanumeric

– bottom: 7-digit alphanumeric

and additional 50-segment bargraph for indication of analog output in percentage.

User-definable matrix display mode with HART communication:

– process variable in pressure unit or

– output signal as percentage, current or engineering units

Display also indicates in/out transfer function, static pressure, sensor temperature and diagnostic messages and provides configuration facilities.

Optional surge protection

Up to 4kV

– voltage 1.2μs rise time / 50μs delay time to half value

– current 8μs rise time / 20μs delay time to half value

Output signal

Two-wire 4 to 20mA, user-selectable for linear or 5th order or two 2nd order switching point selectable programmable polynomial output.

HART® communication provides digital process variable (% , mA or engineering units) superimposed on 4 to 20mA signal, with protocol based on Bell 202 FSK standard.

Output current limits (to NAMUR standard)

Overload condition

- Lower limit: 3.8mA

- Upper limit: 20.5mA

Transmitter failure mode (to NAMUR standard)

The output signal can be user-selected to a value of 3.7 or 22mA on gross transmitter failure condition, detected by self-diagnostics.

In case of CPU failure the output is driven <3.7mA or >22mA.

PROFIBUS PA output

Device type

Pressure transmitter compliant to Profiles 3.0 Class A & B; ident. number 052B HEX.

Power supply

The transmitter operates from 9 to 32VDC, polarity independent.

For EEx ia approval power supply must not exceed 17.5VDC. Intrinsic safety installation according to FISCO model.

Current consumption

operating (quiescent): 10.5mA

fault current limiting: 20mA max.

Output signal

Physical layer in compliance to IEC 1158-2/EN 61158-2 with transmission to Manchester II modulation, at 31.25kbit/sec.

Output interface

PROFIBUS PA communication according to Profibus DP50170 Part 2/ DIN 19245 part 1-3.

Output update time

25ms

Function blocks

2 analog input, 1 transducer, 1 physical

Integral display

LCD, 15 lines x 56 column dot matrix providing 2 lines indication as

– top: 5-digit (numeric) plus sign or 7-digit alphanumeric

– bottom: 7-digit alphanumeric

and additional 50-segment bargraph for indication of output in percentage of the analog input function block assigned to the primary variable.

User-definable matrix display mode:

– process variable in pressure units or

– primary variable in engineering units (output of transducer block) or

– output as percentage or engineering units of analog input function blocks

Display also indicates diagnostic messages and provides configuration facilities.

Secondary variable, static pressure and sensor temperature can be read.

Transmitter failure mode

On gross transmitter failure condition, detected by self-diagnostics, the output signal can be driven to defined conditions, selectable by the user as safe, last valid or calculated value. If electronic failure or short circuit occur the transmitter consumption is electronically limited at a defined value (20mA approx), for safety of the network.

FOUNDATION Fieldbus output

Device type

LINK MASTER DEVICE

Link Active Scheduler (LAS) capability implemented.

Power supply

The transmitter operates from 9 to 32VDC, polarity independent.

For EEx ia approval power supply must not exceed 24VDC (entity certification) or 17.5VDC (FISCO certification), according to FF-816.

Current consumption

operating (quiescent): 10.5mA

fault current limiting: 20mA max.

Output signal

Physical layer in compliance to IEC 1158-2/EN 61158-2 with transmission to Manchester II modulation, at 31.25kbit/sec.

Function blocks/execution period

2 enhanced Analog Input blocks/25ms max (each)

1 enhanced PID block/40ms max.

1 standard ARithmetic block/25ms

1 standard Input Selector block/25ms

1 standard Control Selector block/25ms

1 standard Signal Characterization block/25ms

1 standard Integrator/Totalizer block/25ms

Additional blocks

1 enhanced Resource block

1 custom Pressure with calibration transducer block

1 custom Advanced Diagnostics transducer block including Plugged Input Line Detection

1 custom Local Display transducer block

Number of link objects

35

Number of VCRs

35

Output interface

FOUNDATION fieldbus digital communication protocol to standard H1, compliant to specification V. 1.6; FF registration in progress.

Integral display

LCD, 15 lines x 56 column dot matrix providing 2 lines indication as

– top: 5-digit (numeric) plus sign or 7-digit alphanumeric

– bottom: 7-digit alphanumeric

and additional 50-segment bargraph for percentage indication of the analog input function block output, assigned to the primary variable.

User-definable matrix display mode:

– process variable in pressure units or

– primary variable in engineering units (output of transducer block) or

– output as percentage or engineering units of one or more selected function blocks

Display also indicates diagnostic messages. Secondary variable, static pressure and sensor temperature can be read.

Transmitter failure mode

The output signal is "frozen" to the last valid value on gross transmitter failure condition, detected by self-diagnostics which also indicate a BAD conditions. If electronic failure or short circuit occur the transmitter consumption is electronically limited at a defined value (20mA approx), for safety of the network.

Performance specifications

Stated at reference condition to IEC 60770 ambient temperature of 20°C (68°F), relative humidity of 65%, atmospheric pressure of 1013hPa (1013mbar), zero based range for transmitter with isolating diaphragms in AISI 316 L ss or Hastelloy and silicone oil fill and HART digital trim values equal to 4–20mA span end points, in linear mode.

Unless otherwise specified, errors are quoted as % of span.

Some performance data are affected by the actual turndown (TD) as ratio between Upper Range Limit (URL) and calibrated span.

IT IS RECOMMENDED TO SELECT THE TRANSMITTER SENSOR CODE PROVIDING THE TURNDOWN VALUE AS LOWEST AS POSSIBLE TO OPTIMIZE PERFORMANCE CHARACTERISTICS.

Dynamic performance (according to IEC 61298–1 definition)

Dead time: 40ms

Time constant (63.2% of total step change):

– sensor V: 150ms

– sensors M to S: ≤ 70ms

– sensor H: 100ms

– sensor G: 130ms

Response time (total) = dead time + time constant

Accuracy rating

% of calibrated span, including combined effects of terminal based linearity, hysteresis and repeatability.

For fieldbus versions SPAN refer to analog input function block outscale range

Model 264HS

– ±0.075% for TD from 1:1 to 15:1 (to 10:1 for sensor code E)

– $\pm 0.005\% \times \frac{\text{URL}}{\text{Span}}$ for TD from 15:1 to 60:1

($\pm 0.0075\% \times \frac{\text{URL}}{\text{Span}}$ for sensor code E for TD from 10:1 to 30:1)

Model 264NS

– ±0.075% for TD from 1:1 to 10:1

– $\pm 0.0075\% \times \frac{\text{URL}}{\text{Span}}$ for TD from 10:1 to 20:1

Operating influences

Ambient temperature

per 20K (36°F) change between the limits of –20°C to +65°C (–4 to +150°F) :

Model	Sensor Code	for TD up to	
264HS	E	10:1	± (0.04% URL + 0.065% span)
	G to V	15:1	
264NS	G to S	10:1	± (0.04% URL + 0.065% span)

Optional CoMeter and ProMeter ambient temperature

Total reading error per 20K (36°F) change between the ambient limits of –20 and +70°C (–4 and +158°F) :

±0.15% of max span (16mA).

Supply voltage

Within voltage/load specified limits the total effect is less than 0.005% of URL per volt.

Load

Within load/voltage specified limits the total effect is negligible.

Electromagnetic field

Total effect : less than 0.10% of span from 20 to 1000MHz and for field strengths up to 30V/m when tested with shielded conduit and grounding, with or without meter.

Common mode interference

No effect from 100Vrms @ 50Hz, or 50VDC

Mounting position

No effect

Stability

±0.15% of URL over a five years period

Vibration effect

±0.10% of URL (according to IEC 61298–3)

Physical Specification

(Refer to ordering information sheets for variant availability related to specific model or versions code)

Materials

Process isolating diaphragms (*)

AISI 316 L ss; AISI 316 L ss gold plated; Monel 400™; Tantalum;
Hastelloy C276™; Hastelloy C276™ on AISI 316 L ss seat;
Hastelloy C276™ gold plated.

Process connection (*)

AISI 316 L ss; Hastelloy C276™; Monel 400™.

Sensor fill fluid

Silicone oil (DC200™);
inert fill (Halocarbon 4.2™ or Galden™; carbon fluoride for sensor V)

Mounting bracket (**)

Zinc plated carbon steel with chrome passivation;
AISI 316 L ss.

Sensor housing

AISI 316 L ss.

Electronic housing and covers

Barrel version
– Aluminium alloy with baked epoxy finish;
– Copper-free content aluminium alloy with baked epoxy finish;
– AISI 316 L ss.

Covers O-ring

Buna N.

Local zero and span adjustments:

Glass filled polycarbonate plastic (removable).

Tagging

AISI 316ss data plate attached to the electronics housing.

Calibration

Standard: at maximum span, zero based range, ambient temperature and pressure;
Optional: at specified range and ambient conditions.

Optional extras

Mounting brackets

For 60mm. (2in) pipes or wall mounting.

Output indicator

plug-in rotatable type, LCD or analog.

Supplemental customer tag

AISI 316 ss tag screwed/fastened to the transmitter for customer's tag data up to a maximum of 20 characters and spaces on one line for tag number and tag name, and up to a maximum of 3 spaced strings of 10 characters each for calibration details (lower and upper values plus unit). Special typing evaluated on request for charges.

Surge protection (only as external unit for PROFIBUS PA and FF)

Cleaning procedure for oxygen service

Test Certificates (test, design, calibration, material traceability)

Tag and manual language

Communication connectors

Process connections

1/2 – 14 NPT female or male; DIN EN837–1 G 1/2 B; adapter straight (180°) entry; adapter angle (90°) entry.

fixing threads on adapter entries: 7/16 – 20 UNF at 41.3mm centre distance.

Electrical connections

Two 1/2 – 14 NPT or M20x1.5 or PG 13.5 or 1/2 GK threaded conduit entries, direct on housing.

Special communication connector (on request)

– HART : straight or angle Harting Han connector and one plug.

– FOUNDATION Fieldbus, PROFIBUS PA: M12x1 or 7/8.

Terminal block

HART version: three terminals for signal/external meter wiring up to 2.5mm² (14AWG) and three connection points for test and communication purposes.

Fieldbus versions: two terminals for signal wiring (bus connection) up to 2.5mm² (14AWG)

Grounding

Internal and external 6mm² (10AWG) ground termination points are provided.

Mounting position

Transmitter can be mounted in any position.

Electronics housing may be rotated to any position. A positive stop prevents over travel.

Mass (without options)

1.7kg approx (4lb); add 1.5kg (3.4lb) for AISI housing.
Add 650g (1.5lb) for packing.

Packing

Carton 26 x 26 x 18cm approx (10 x 10 x 7in).

™ Hastelloy is a Cabot Corporation trademark

™ Monel is an International Nickel Co. trademark

™ DC 200 is a Dow Corning Corporation trademark

™ Galden is a Montefluos trademark

™ Halocarbon is a Halocarbon Products Co. trademark

(*) Wetted parts of the transmitter.

(**) U-bolt material: AISI 400 ss; screws material: high-strength alloy steel or AISI 316 ss.

Configuration

Transmitter with HART communication and 4 to 20 mA

Standard configuration

Transmitters are factory calibrated to customer's specified range. Calibrated range and tag number are stamped on the tag plate. If a calibration range and tag data are not specified, the transmitter will be supplied with the plate left blank and configured as follows:

Engineering Unit	kPa
4 mA	Zero
20 mA	Upper Range Limit (URL)
Output	Linear
Damping	1 sec.
Transmitter failure mode	Upscale
Software tag (8 characters max)	Blank
Optional LCD indicator/display	0 to 100.0% linear

Any or all the above configurable parameters, including Lower range-value and Upper range-value which must be the same unit of measure, can be easily changed using the HART hand-held communicator or by a PC running the configuration software SMART VISION with DTM for 2600T. The transmitter database is customized with specified flange type and material, O-ring and drain/vent materials and meter code option.

Custom configuration (option)

The following data may be specified in addition to the standard configuration parameters:

Descriptor	16 alphanumeric characters
Message	32 alphanumeric characters
Date	Day, month, year

Transmitter with PROFIBUS PA communication

Transmitters are factory calibrated to customer's specified range. Calibrated range and tag number are stamped on the tag plate. If a calibration range and tag data are not specified, the transmitter will be supplied with the plate left blank and configured as follows:

Measure Profile	Pressure
Engineering Unit	kPa
Output scale 0%	Lower Range Limit (LRL)
Output scale 100%	Upper Range Limit (URL)
Output	Linear
Hi-Hi Limit	Upper Range Limit (URL)
Hi Limit	Upper Range Limit (URL)
Low Limit	Lower Range Limit (LRL)
Low-Low Limit	Lower Range Limit (LRL)
Limits hysteresis	0.5% of output scale
PV filter	0 sec.
Address (settable by local key)	126
Tag	32 alphanumeric characters

Any or all the above configurable parameters, including Lower range-value and Upper range-value which must be the same unit of measure, can be easily changed by a PC running the configuration software SMART VISION with DTM for 2600T.

The transmitter database is customized with specified flange type and material, O-ring and drain/vent materials and meter code option.

Custom configuration (option)

The following data may be specified in addition to the standard configuration parameters:

Descriptor	32 alphanumeric characters
Message	32 alphanumeric characters
Date	Day, month, year

Transmitter with FOUNDATION Fieldbus communication

Transmitters are factory calibrated to customer's specified range. Calibrated range and tag number are stamped on the tag plate. If a calibration range and tag data are not specified, the transmitter will be supplied with the plate left blank and the analog input function block FB1 is configured as follows:

Measure Profile	Pressure
Engineering Unit	kPa
Output scale 0%	Lower Range Limit (LRL)
Output scale 100%	Upper Range Limit (URL)
Output	Linear
Hi-Hi Limit	Upper Range Limit (URL)
Hi Limit :	Upper Range Limit (URL)
Low Limit	Lower Range Limit (LRL)
Low-Low Limit	Lower Range Limit (LRL)
Limits hysteresis	0.5% of output scale
PV filter time	0 sec.
Tag	32 alphanumeric characters

The analog input function block FB2 is configured for the sensor temperature measured in °C. Any or all the above configurable parameters, including the range values, can be changed using any host compliant to FOUNDATION fieldbus. The transmitter database is customized with specified flange type and material, O-ring and drain/vent materials and meter code option.

For any protocol available engineering units of pressure measure are :

Pa, kPa, MPa
 inH₂O@4°C, mmH₂O@4°C, psi
 inH₂O@20°C, ftH₂O@20°C, mmH₂O@20°C
 inHg, mmHg, Torr
 g/cm², kg/cm², atm
 mbar, bar

MOUNTING DIMENSIONS (not for construction unless certified) – dimensions in mm (in)

Transmitter with barrel housing on bracket for 60mm (2in) pipe mounting

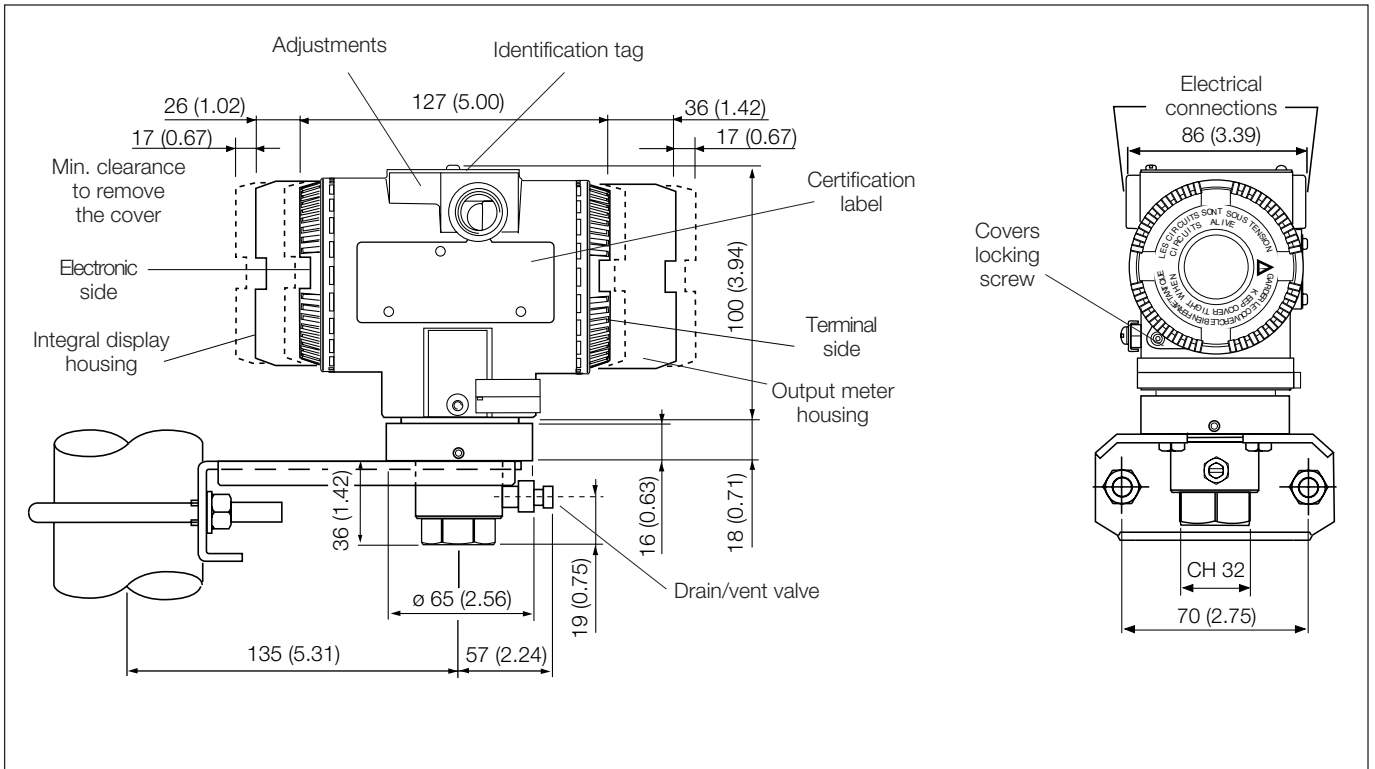

1/2 – 14 NPT female connection for sensors E, G, H, M, P, Q, S

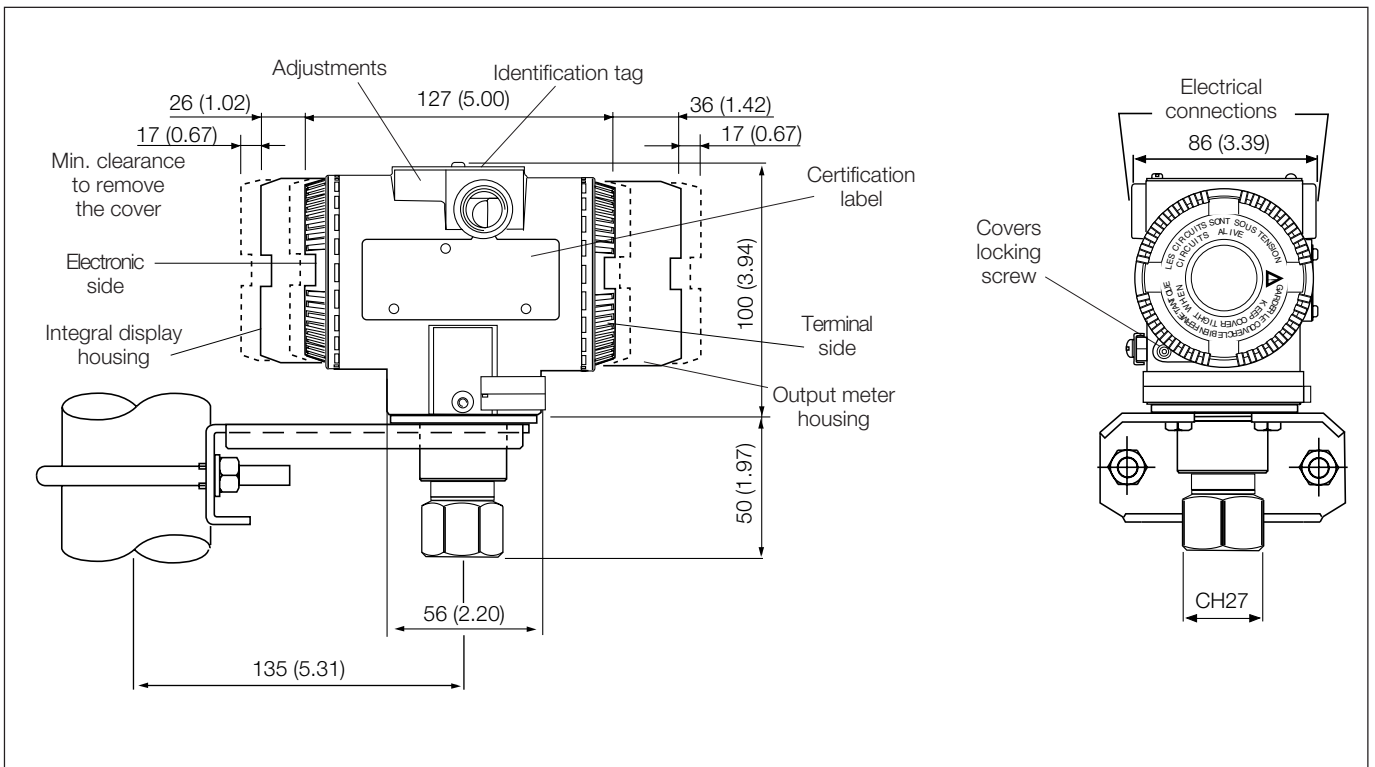

1/2 – 14 NPT female connection for sensor V (NOT FOR 264NS)

2600T Pressure Transmitters

Model 264HS, 264NS

SS/264HS/NS_8

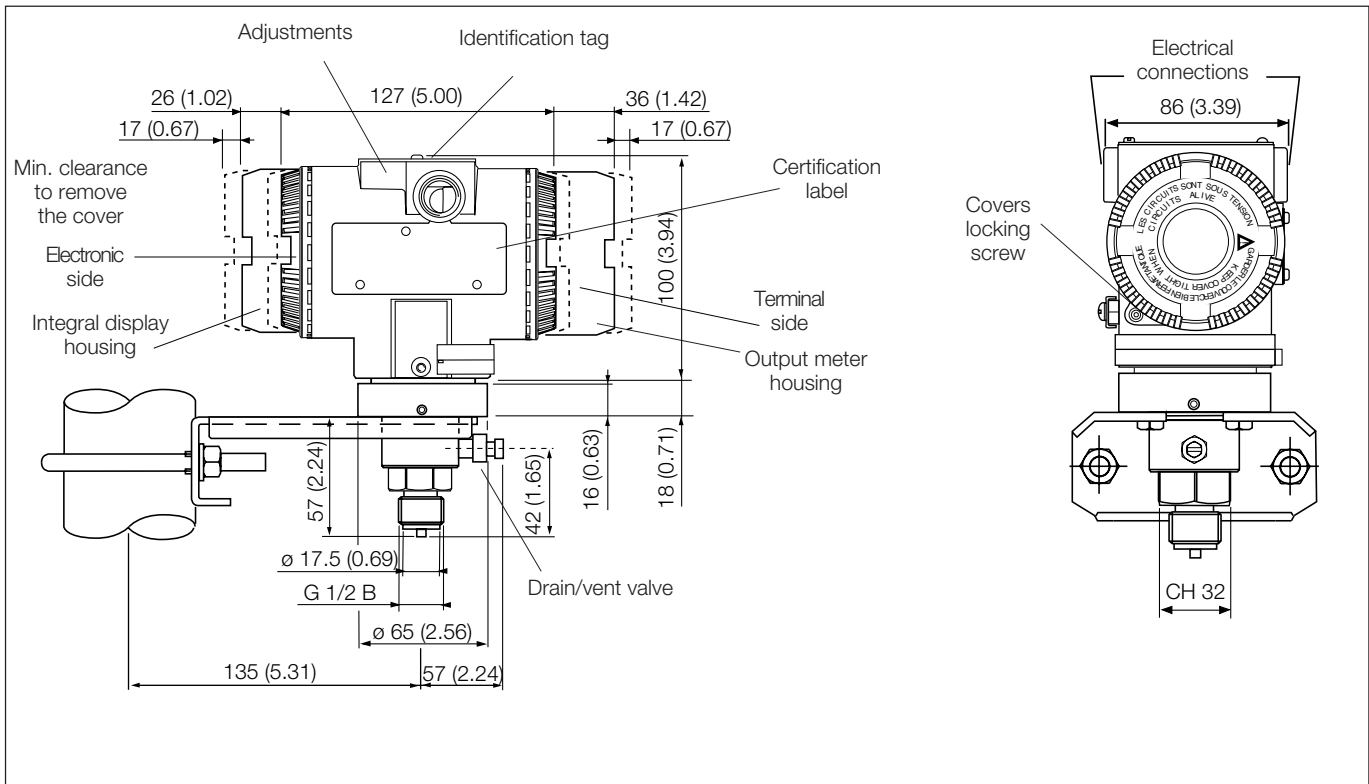

DIN-EN837-1 G 1/2 B connection for sensors E, G, H, M, P, Q, S

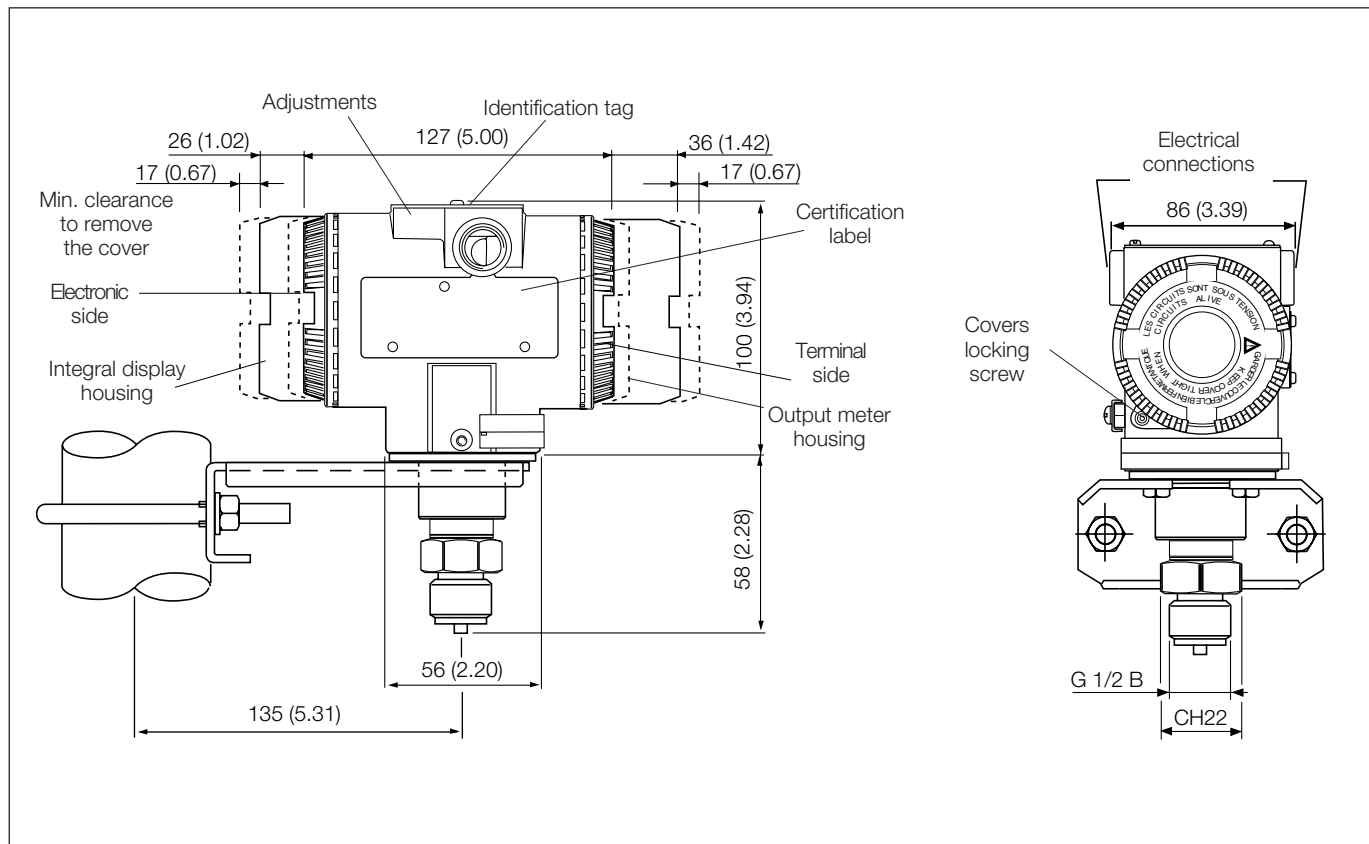

DIN-EN837-1 G 1/2 B connection for sensor V (NOT FOR 264NS)

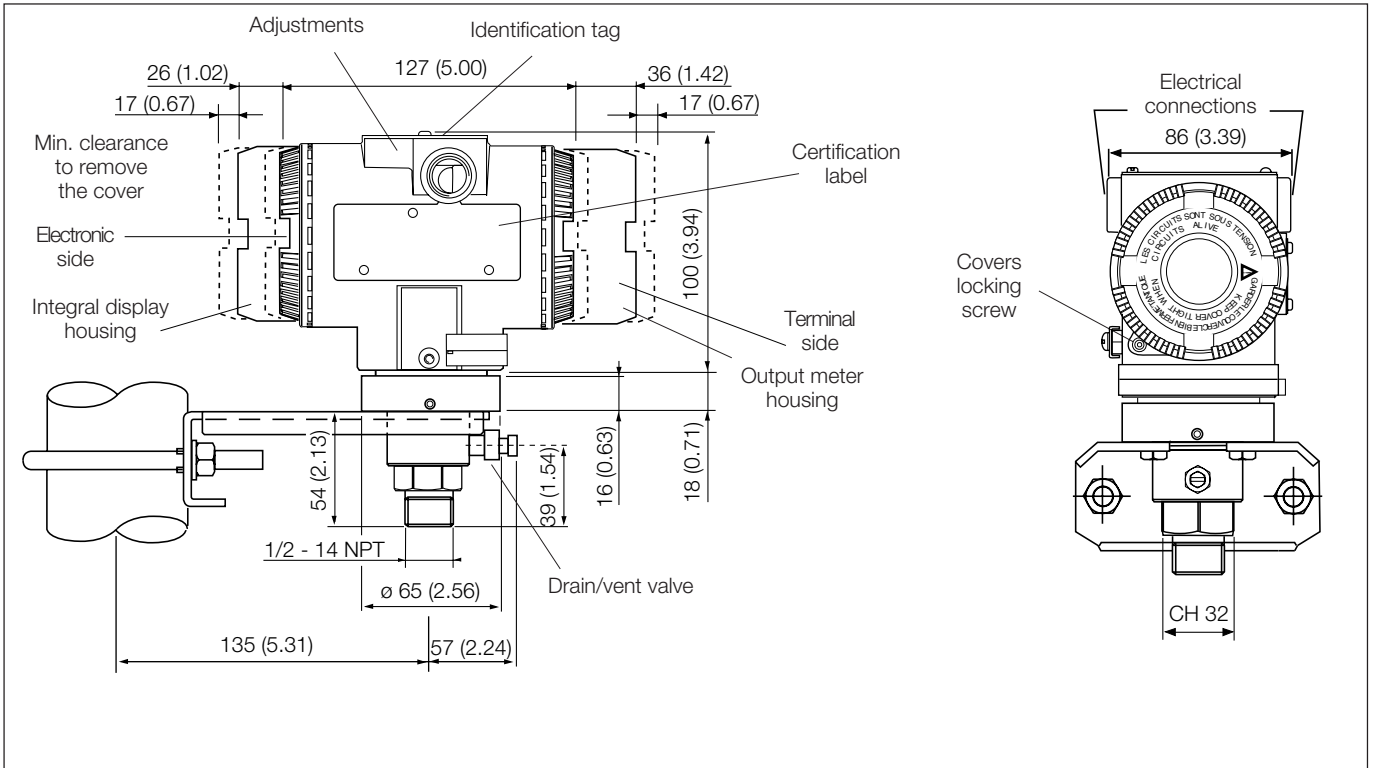

1/2 - 14 NPT male connection for sensors E, G, H, M, P, Q, S

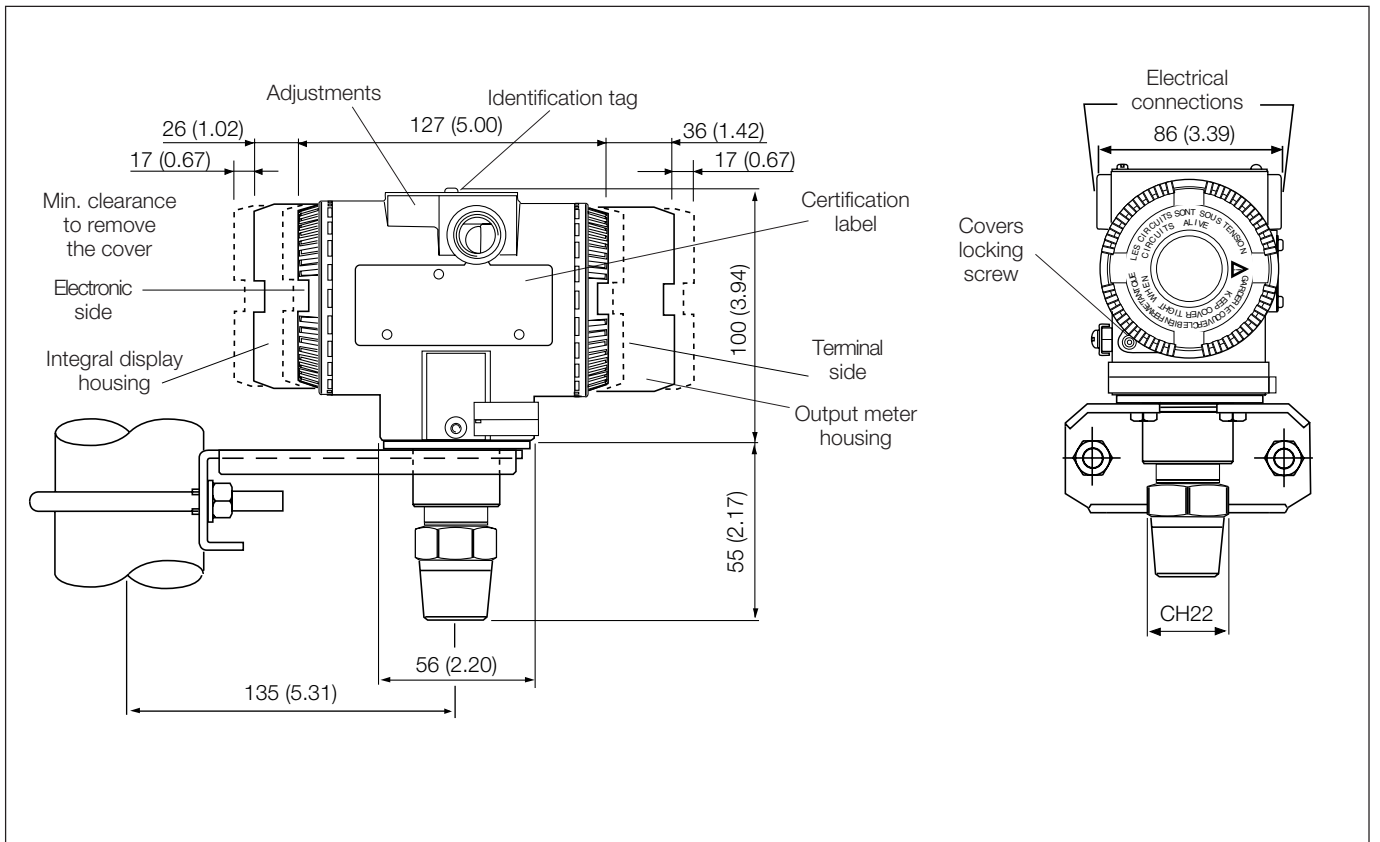

1/2 - 14 NPT male connection for sensor V (NOT FOR 264NS)

Electrical connections

HART Version

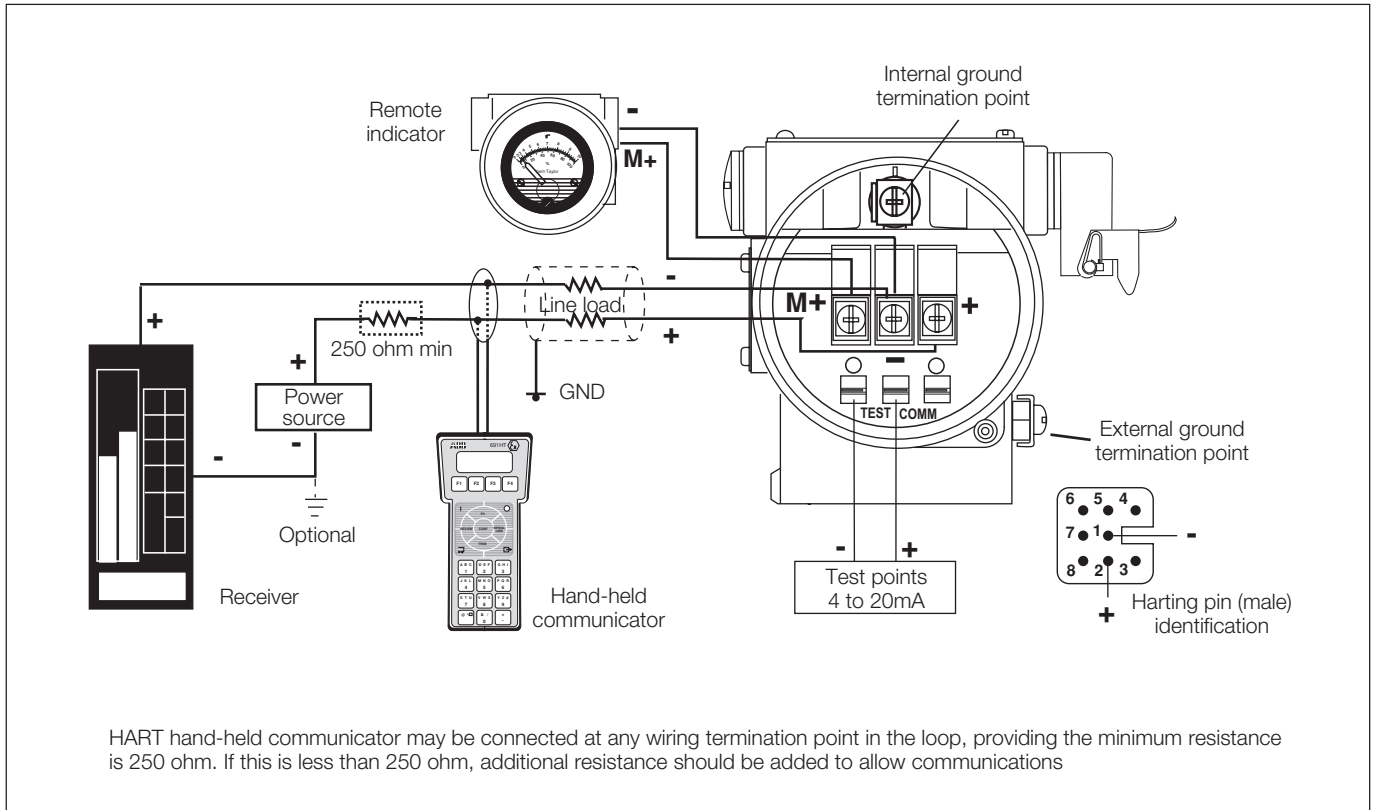

FIELDBUS Versions

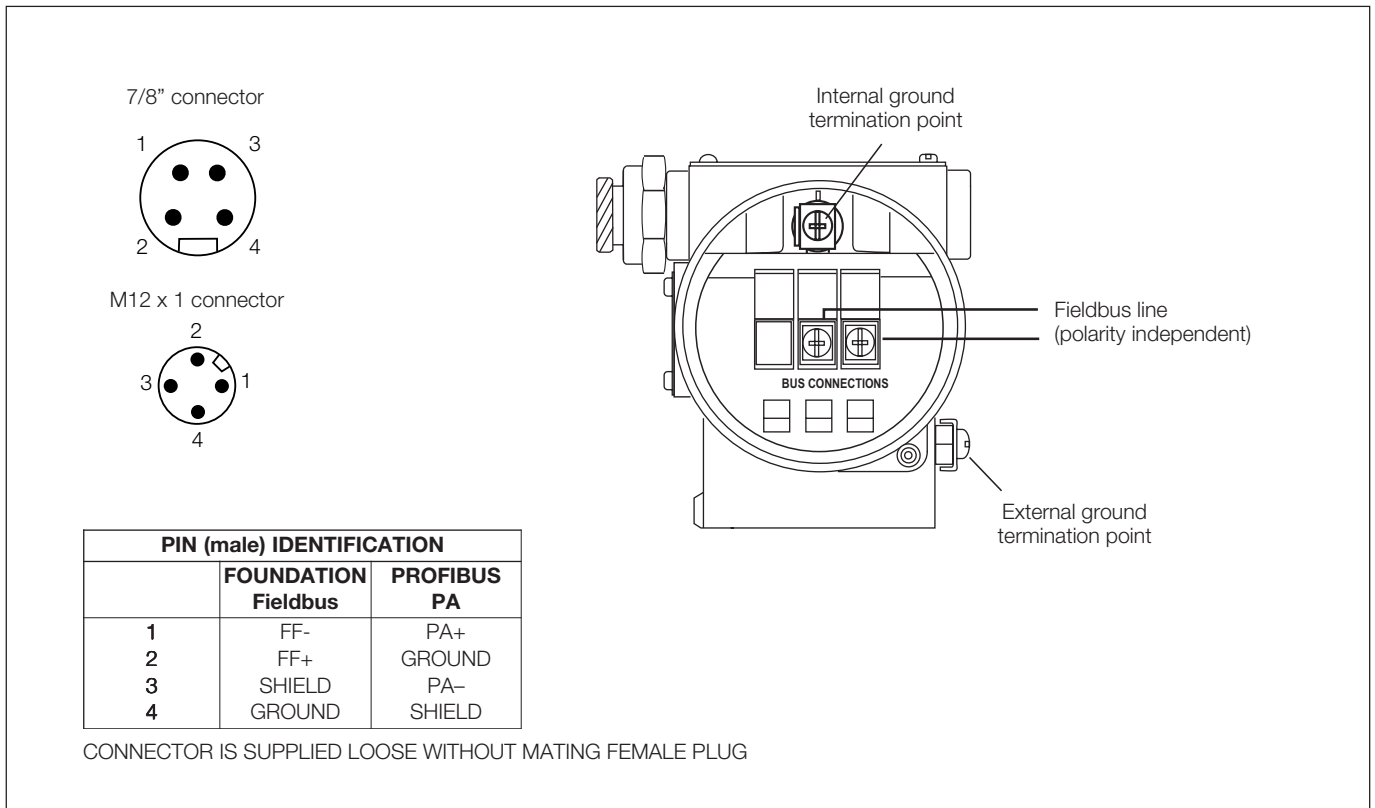

BASIC ORDERING INFORMATION model 264HS Gauge Pressure Transmitter

Select one character or set of characters from each category and specify complete catalog number.

Refer to additional ordering information code and specify one or more codes for each transmitter if additional options are required.

BASE MODEL – 1 st to 5 th characters			2	6	4	H	S	X	X	X	X	X
Gauge Pressure Transmitter – BASE ACCURACY 0.075%												
SENSOR - Span limits – 6th character												
0.27 and 16kPa	2.7 and 160mbar	1.08 and 64inH ₂ O						E				
0.65 and 65kPa	6.5 and 650mbar	2.6 and 260inH ₂ O						G				
1.6 and 160kPa	16 and 1600mbar	6.4 and 642inH ₂ O						H				
6 and 600kPa	0.06 and 6bar	0.87 and 87psi						M				
24 and 2400kPa	0.24 and 24bar	3.5 and 348psi						P				
80 and 8000kPa	0.8 and 80bar	11.6 and 1160psi						Q				
160 and 16000kPa	1.6 and 160bar	23.2 and 2320psi						S				
600 and 60000 kPa	6 and 600bar	87 and 8700 psi						V				
Diaphragm material / Fill fluid (wetted parts) – 7th character												
AISI 316 L ss		Silicone oil (Note 2)						NACE	S			
Hastelloy C276™ (on AISI seat)		Silicone oil (Note 2)						NACE	H			
Hastelloy C276™		Silicone oil						NACE	K			
Hastelloy C276™ gold plated		Silicone oil (Note 14)						NACE	G			
Monel 400™		Silicone oil (Note 2)						NACE	M			
AISI 316 L ss gold plated		Silicone oil (Notes 2, 15)							8			
Tantalum		Silicone oil (Note 2)						NACE	T			
AISI 316 L ss		Inert fluid - Galden (Notes 1, 2)							A			
Hastelloy C276™ (on AISI seat)		Inert fluid - Galden (Notes 1, 2)						NACE	B			
Hastelloy C276™		Inert fluid - Galden (Carbon fluoride for sensor V) (Note 1)						NACE	F			
Hastelloy C276™ gold plated		Inert fluid - Galden (Carbon fluoride for sensor V) (Notes 1, 14)						NACE	E			
Monel 400™		Inert fluid - Galden (Notes 1, 2)						NACE	C			
AISI 316 L ss gold plated		Inert fluid - Galden (Notes 1, 2, 15)							9			
Tantalum		Inert fluid - Galden (Notes 1, 2)						NACE	D			
AISI 316 L ss		Inert fluid - Halocarbon (Notes 1, 2)							L			
Hastelloy C276™ (on AISI seat)		Inert fluid - Halocarbon (Notes 1, 2)						NACE	Q			
Hastelloy C276™		Inert fluid - Halocarbon (Notes 1, 2)						NACE	P			
Monel 400™		Inert fluid - Halocarbon (Notes 1, 2)						NACE	4			
AISI 316 L ss gold plated		Inert fluid - Halocarbon (Notes 1, 2, 15)							I			
Tantalum		Inert fluid - Halocarbon (Notes 1, 2)						NACE	5			
Process connection material (wetted parts) – 8th character												
AISI 316 L ss		1/2 – 14 NPT female (Note 3)						NACE	B			
AISI 316 L ss		1/2 – 14 NPT male (Note 3)						NACE	T			
AISI 316 L ss		DIN EN837-1 G 1/2 B (Note 3)						NACE	P			
AISI 316 L ss		Adapter straight (180°) entry (not available with bracket) (Notes 2, 3)						NACE	A			
AISI 316 L ss		Adapter angle (90°) entry (Notes 2, 3)						NACE	N			
Hastelloy C276™		1/2 – 14 NPT female (Note 4)						NACE	E			
Hastelloy C276™		1/2 – 14 NPT male (Note 4)						NACE	K			
Hastelloy C276™		DIN EN837-1 G 1/2 B (Note 4)						NACE	D			
Hastelloy C276™		Adapter straight (180°) entry (not available with bracket) (Notes 2, 4)						NACE	F			
Hastelloy C276™		Adapter angle (90°) entry (Notes 2, 4)						NACE	C			
Monel 400™		1/2 – 14 NPT female (Note 5)						NACE	1			
Monel 400™		1/2 – 14 NPT male (Note 5)						NACE	2			
Monel 400™		DIN EN837-1 G 1/2 B (Note 5)						NACE	3			
Housing material and electrical connection – 9th character												
Aluminium alloy (Barrel version)		1/2 – 14 NPT										A
Aluminium alloy (Barrel version)		M20 x 1.5 (CM 20)										B
Aluminium alloy (Barrel version)		Pg 13.5										D
Aluminium alloy (Barrel version)		1/2 GK										C
Aluminium alloy (Barrel version)		Harting Han connector (general purpose only)						(Note 6)				E
Aluminium alloy (Barrel version)		Fieldbus connector (general purpose only)						(Note 6)				G
Aluminium alloy copper-free (Barrel version)		1/2 – 14 NPT										H
Aluminium alloy copper-free (Barrel version)		M20 x 1.5 (CM 20)										L
Aluminium alloy copper-free (Barrel version)		Pg 13.5										N
Aluminium alloy copper-free (Barrel version)		1/2 GK										M
Aluminium alloy copper-free (Barrel version)		Harting Han connector (general purpose only)						(Note 6)				P
Aluminium alloy copper-free (Barrel version)		Fieldbus connector (general purpose only)						(Note 6)				R
AISI 316 L ss (Barrel version)		1/2 – 14 NPT										S
AISI 316 L ss (Barrel version)		M20 x 1.5 (CM20)										T
AISI 316 L ss (Barrel version)		Pg 13.5										V
AISI 316 L ss (Barrel version)		1/2 GK										U
AISI 316 L ss (Barrel version)		Fieldbus connector (general purpose only)						(Note 6)				Z
Output/Additional options – 10th character												
HART digital communication and 4 to 20mA		No additional options (Notes 7, 8)										H
HART digital communication and 4 to 20mA		Options requested (to be ordered by "Additional ordering code") (Note 7)										1
PROFIBUS PA		No additional options (Notes 7, 8)										P
PROFIBUS PA		Options requested (to be ordered by "Additional ordering code") (Note 8)										2
FOUNDATION Fieldbus		No additional options (Notes 7, 8)										F
FOUNDATION Fieldbus		Options requested (to be ordered by "Additional ordering code") (Note 8)										3

ADDITIONAL ORDERING INFORMATION for model 264HS

Add one or more 2-digit code(s) after the basic ordering information to select all required options

	XX	XX	XX	XX	XX	XX	XX	XX	XX	XX	XX	XX	XX	XX	XX
Drain/vent valve (wetted parts)															
AISI 316 L ss	(Notes 2, 9)	NACE	VA												
Hastelloy C276™	(Notes 2, 10)	NACE	VB												
Monel 400™	(Notes 2, 11)	NACE	VC												
Electrical certification															
ATEX Group II Category 1 GD – Intrinsic Safety EEx ia															E1
ATEX Group II Category 1/2 GD – Flameproof EEx d															E2
ATEX Group II Category 3 GD – Type of protection "N" EEx nL design compliance (Note 12)															E3
Canadian Standard Association (CSA) (only 1/2–14NPT, M20 and Pg 13.5 electrical connection)															E4
Standards Australia SAA (Not Ex ia and Ex n for PROFIBUS PA and FOUNDATION Fieldbus)															E5
Factory Mutual (FM) approval (only with 1/2–14NPT, M20 and Pg 13.5 electrical connection)															E6
Combined ATEX - Intrinsic Safety and Flameproof															E7
Combined ATEX, FM and CSA (only with 1/2–14NPT, M20 and Pg 13.5 electrical connection) (Note 12)															EN
NEPSI (China) - Intrinsic Safety Ex ia															EY
NEPSI (China) - Flameproof Ex d															EZ
GOST (Russia) EEx ia															W1
GOST (Russia) EEx d															W2
GOST (Kazakhstan) EEx ia															W3
GOST (Kazakhstan) EEx d															W4
Inmetro (Brazil) EEx ia															W5
Inmetro (Brazil) EEx d															W6
Inmetro (Brazil) EEx nL															W7
Metrologic (Russia)															WC
Metrologic (Kazakhstan)															WD
Output meter															
ProMeter, Standard calibration	(Note 12)														D1
ProMeter, Special calibration	(Note 12)														D2
Analog output indicator linear 0–100% scale	(Note 12)														D3
Analog output indicator, special graduation (to be specified for linear scale)	(Note 12)														D5
Programmable signal meter and HART configurator (CoMeter)	(Note 12)														D7
Programmable signal meter and HART configurator (CoMeter – customer configuration)	(Note 12)														D8
Integral LCD															
Digital LCD integral display															L1
Mounting bracket (shape and material)															
For pipe mounting (Not suitable for AISI housing)	Carbon steel														B1
For pipe mounting	AISI 316 L ss														B2
Surge															
Surge/Transient Protector (Internal for HART / 4-20mA)															
Surge/Transient Protector (External supplied loose for PROFIBUS PA and FOUNDATION Fieldbus only suitable with 1/2–14NPT and M20 electrical connection and with ATEX, FM and CSA certifications, no DUST)															S1
Operating manual															
German															M1
Italian															M2
Spanish															M3
French															M4
Labels & tag language															
German															T1
Italian															T2
Spanish															T3
French															T4
Additional tag plate															
Laser printing of tag on stainless steel plate															I2
Configuration															
Standard – Pressure = inH ₂ O/psi at 20° C; Temperature = deg. F															N2
Standard – Pressure = inH ₂ O/psi at 4° C; Temperature = deg. F															N3
Standard – Pressure = inH ₂ O/psi at 20° C; Temperature = deg. C															N4
Standard – Pressure = inH ₂ O/psi at 4° C; Temperature = deg. C															N5
Custom															N6
Preparation procedure															
Oxygen service cleaning (only available with inert fill)															P1
P _{max} = 12MPa for Galden, 9MPa for Halocarbon or 21MPa for Carbon fluoride; T _{max} = 60° C/140° F															
Certificates															
Inspection certificate EN 10204–3.1 of calibration (9-point)															C1
Certificate of compliance with the order EN 10204–2.1 of instrument design															C6
Material traceability															
Certificate of compliance with the order EN 10204–2.1 of process wetted parts															H1
Inspection certificate EN 10204–3.1 of process wetted parts															H3
Connector															
Fieldbus 7/8 (Recommended for FOUNDATION Fieldbus) - (supplied loose without mating female plug)	(Notes 8, 13)														U1
Fieldbus M12x1 (Recommended for PROFIBUS PA) - (supplied loose without mating female plug)	(Notes 8, 13)														U2
Harting Han – straight entry	(Notes 7, 13)														U3
Harting Han – angle entry	(Notes 7, 13)														U4

- Note 1: Suitable for oxygen service
- Note 2: Not available with Sensor code V
- Note 3: Not available with diaphragm code K, F combined with sensor codes G to S and with diaphragm code M, T, C, D, P, 4, 5
- Note 4: Not available with diaphragm code S, H, A, B, L, Q, M, C, 4, 8, 9, I
- Note 5: Not available with diaphragm code S, H, K, T, A, B, F, D, L, Q, P, 5, E, G, 8, 9, I
- Note 6: Select type in additional ordering code
- Note 7: Not available with Electronic Housing code Z, R, G
- Note 8: Not available with Electronic Housing code P, E
- Note 9: Not available with Process connection code E, K, D, F, C, 1, 2, 3
- Note 10: Not available with Process connection code B, T, A, P, N, 1, 2, 3
- Note 11: Not available with Process connection code E, K, D, F, C, B, T, A, P, N
- Note 12: Not available with PROFIBUS PA and FF output code 2 or 3
- Note 13: Not available with Electronic housing code U, S, T, V, H, M, L, N, D, C, A, B
- Note 14: Not available with sensor code E to S (suitable only for sensor code V)
- Note 15: Not available with sensor code E

- ™ Hastelloy is a Cabot Corporation trademark
- ™ Monel is an International Nickel Co. trademark
- ™ Galden is a Montefluos trademark
- ™ Halocarbon is a Halocarbon Products Co. trademark

Standard delivery items (can be differently specified by additional ordering code)

- No drain/vent valve
- General purpose (no electrical certification)
- No meter/display, no mounting bracket, no surge protection
- English manual and labels
- Configuration with kPa and deg. C units
- No test, inspection or material traceability certificates

THE SELECTION OF SUITABLE WETTED PARTS AND FILLING FLUID FOR COMPATIBILITY WITH THE PROCESS MEDIA IS A CUSTOMER'S RESPONSIBILITY, IF NOT OTHERWISE NOTIFIED BEFORE MANUFACTURING.

BASIC ORDERING INFORMATION model 264NS Absolute Pressure Transmitter

Select one character or set of characters from each category and specify complete catalog number.
Refer to additional ordering information code and specify one or more codes for each transmitter if additional options are required.

BASE MODEL – 1 st to 5 th characters				2	6	4	N	S	X	X	X	X	X
Absolute Pressure Transmitter – BASE ACCURACY 0.075%													
SENSOR - Span limits – 6th character													
1.1 and 65kPa	11 and 650mbar	8 and 480mmHg							G				
2.67 and 160kPa	26.7 and 1600mbar	20 and 1200mmHg							H				
10 and 600kPa	0.1 and 6bar	1.45 and 87psi							M				
40 and 2400kPa	0.4 and 24bar	5.8 and 348psi							P				
134 and 8000kPa	1.34 and 80bar	19.4 and 1160psi							Q				
267 and 16000kPa	2.67 and 160bar	38.7 and 2320psi							S				
Diaphragm material / Fill fluid (wetted parts) – 7th character													
AISI 316 L ss	Silicone oil										S		
Hastelloy C276™ (on AISI seat)	Silicone oil								NACE		H		
Hastelloy C276™	Silicone oil								NACE		K		
AISI 316 L ss	Inert fluid - Galden	(Note 1)									A		
Hastelloy C276™ (on AISI seat)	Inert fluid - Galden	(Note 1)							NACE		B		
Hastelloy C276™	Inert fluid - Galden	(Note 1)							NACE		F		
AISI 316 L ss	Inert fluid - Halocarbon	(Note 1)									L		
Hastelloy C276™ (on AISI seat)	Inert fluid - Halocarbon	(Note 1)							NACE		Q		
Hastelloy C276™	Inert fluid - Halocarbon	(Note 1)							NACE		P		
Process connection material (wetted parts) – 8th character													
AISI 316 L ss	1/2 – 14 NPT female	(Note 2)							NACE		B		
AISI 316 L ss	1/2 – 14 NPT male	(Note 2)							NACE		T		
AISI 316 L ss	DIN EN837-1 G 1/2 B	(Note 2)							NACE		P		
AISI 316 L ss	Adapter straight (180°) entry (not available with bracket)	(Note 2)							NACE		A		
AISI 316 L ss	Adapter angle (90°) entry	(Note 2)							NACE		N		
Hastelloy C276™	1/2 – 14 NPT female	(Note 3)							NACE		E		
Hastelloy C276™	1/2 – 14 NPT male	(Note 3)							NACE		K		
Hastelloy C276™	DIN EN837-1 G 1/2 B	(Note 3)							NACE		D		
Hastelloy C276™	Adapter straight (180°) entry (not available with bracket)	(Note 3)							NACE		F		
Hastelloy C276™	Adapter angle (90°) entry	(Note 3)							NACE		C		
Housing material and electrical connection – 9th character													
Aluminium alloy (Barrel version)	1/2 – 14 NPT												A
Aluminium alloy (Barrel version)	M20 x 1.5 (CM 20)												B
Aluminium alloy (Barrel version)	Pg 13.5												D
Aluminium alloy (Barrel version)	1/2 GK												C
Aluminium alloy (Barrel version)	Harting Han connector	(general purpose only)							(Note 4)				E
Aluminium alloy (Barrel version)	Fieldbus connector	(general purpose only)							(Note 4)				G
Aluminium alloy copper-free (Barrel version)	1/2 – 14 NPT												H
Aluminium alloy copper-free (Barrel version)	M20 x 1.5 (CM 20)												L
Aluminium alloy copper-free (Barrel version)	Pg 13.5												N
Aluminium alloy copper-free (Barrel version)	1/2 GK												M
Aluminium alloy copper-free (Barrel version)	Harting Han connector	(general purpose only)							(Note 4)				P
Aluminium alloy copper-free (Barrel version)	Fieldbus connector	(general purpose only)							(Note 4)				R
AISI 316 L ss (Barrel version)	1/2 – 14 NPT												S
AISI 316 L ss (Barrel version)	M20 x 1.5 (CM20)												T
AISI 316 L ss (Barrel version)	Pg 13.5												V
AISI 316 L ss (Barrel version)	1/2 GK												U
AISI 316 L ss (Barrel version)	Fieldbus connector	(general purpose only)							(Note 4)				Z
Output/Additional options – 10th character													
HART digital communication and 4 to 20mA	No additional options	(Notes 5, 6)											H
HART digital communication and 4 to 20mA	Options requested (to be ordered by "Additional ordering code")	(Note 5)											1
PROFIBUS PA	No additional options	(Notes 5, 6)											P
PROFIBUS PA	Options requested (to be ordered by "Additional ordering code")	(Note 6)											2
FOUNDATION Fieldbus	No additional options	(Notes 5, 6)											F
FOUNDATION Fieldbus	Options requested (to be ordered by "Additional ordering code")	(Note 6)											3

ADDITIONAL ORDERING INFORMATION for model 264NS

Add one or more 2-digit code(s) after the basic ordering information to select all required options

	XX	XX	XX	XX	XX	XX	XX	XX	XX	XX	XX	XX	XX	XX	XX
Drain/vent valve (wetted parts)															
AISI 316 L ss	(Note 7)	NACE	VA												
Hastelloy C276™	(Note 8)	NACE	VB												
Electrical certification															
ATEX Group II Category 1 GD – Intrinsic Safety EEx ia															E1
ATEX Group II Category 1/2 GD – Flameproof EEx d															E2
ATEX Group II Category 3 GD – Type of protection "N" EEx nL design compliance (Note 9)															E3
Canadian Standard Association (CSA) (only 1/2–14NPT, M20 and Pg 13.5 electrical connection)															E4
Standards Australia SAA (Not Ex ia and Ex n for PROFIBUS PA and FOUNDATION Fieldbus)															E5
Factory Mutual (FM) approval (only with 1/2–14NPT, M20 and Pg 13.5 electrical connection)															E6
Combined ATEX - Intrinsic Safety and Flameproof															E7
Combined ATEX, FM and CSA (only with 1/2–14NPT, M20 and Pg 13.5 electrical connection) (Note 9)															EN
NEPSI (China) - Intrinsic Safety Ex ia															EY
NEPSI (China) - Flameproof Ex d															EZ
GOST (Russia) EEx ia															W1
GOST (Russia) EEx d															W2
GOST (Kazakhstan) EEx ia															W3
GOST (Kazakhstan) EEx d															W4
Inmetro (Brazil) EEx ia															W5
Inmetro (Brazil) EEx d															W6
Inmetro (Brazil) EEx nL															W7
Metrologic (Russia)															WC
Metrologic (Kazakhstan)															WD
Output meter															
ProMeter, Standard calibration	(Note 9)														D1
ProMeter, Special calibration	(Note 9)														D2
Analog output indicator linear 0–100% scale	(Note 9)														D3
Analog output indicator, special graduation (to be specified for linear scale)	(Note 9)														D5
Programmable signal meter and HART configurator (CoMeter)	(Note 9)														D7
Programmable signal meter and HART configurator (CoMeter – customer configuration)	(Note 9)														D8
Integral LCD															
Digital LCD integral display															L1
Mounting bracket (shape and material)															
For pipe mounting (Not suitable for AISI housing)	Carbon steel														B1
For pipe mounting	AISI 316 L ss														B2
Surge															
Surge/Transient Protector (Internal for HART / 4-20mA)															
Surge/Transient Protector (External supplied loose for PROFIBUS PA and FOUNDATION Fieldbus only suitable with 1/2–14NPT and M20 electrical connection and with ATEX, FM and CSA certifications, no DUST)															S1
Operating manual															
German															M1
Italian															M2
Spanish															M3
French															M4
Labels & tag language															
German															T1
Italian															T2
Spanish															T3
French															T4
Additional tag plate															
Laser printing of tag on stainless steel plate															I2
Configuration															
Standard – Pressure = inH ₂ O/psi at 20° C; Temperature = deg. F															N2
Standard – Pressure = inH ₂ O/psi at 4° C; Temperature = deg. F															N3
Standard – Pressure = inH ₂ O/psi at 20° C; Temperature = deg. C															N4
Standard – Pressure = inH ₂ O/psi at 4° C; Temperature = deg. C															N5
Custom															N6
Preparation procedure															
Oxygen service cleaning (only available with inert fill) – P _{max} = 12MPa for Galden, 9MPa for Halocarbon; T _{max} = 60° C/140° F															P1
Certificates															
Inspection certificate EN 10204–3.1 of calibration (9-point)															C1
Certificate of compliance with the order EN 10204–2.1 of instrument design															C6
Material traceability															
Certificate of compliance with the order EN 10204–2.1 of process wetted parts															H1
Inspection certificate EN 10204–3.1 of process wetted parts															H3
Connector															
Fieldbus 7/8 (Recommended for FOUNDATION Fieldbus) - (supplied loose without mating female plug)															U1
Fieldbus M12x1 (Recommended for PROFIBUS PA) - (supplied loose without mating female plug)															U2
Harting Han – straight entry															U3
Harting Han – angle entry															U4

- Note 1: Suitable for oxygen service
- Note 2: Not available with Hastelloy C diaphragm code K, F, P
- Note 3: Not available with AISI 316 L ss and Hastelloy C on AISI seat diaphragm code S, H, A, B, L, Q
- Note 4: Select type in additional ordering code
- Note 5: Not available with Electronic Housing code Z, R, G
- Note 6: Not available with Electronic Housing code P, E
- Note 7: Not available with Process connection code E, K, D, F, C
- Note 8: Not available with Process connection code B, T, A, P, N
- Note 9: Not available with PROFIBUS PA and FF output code 2 or 3
- Note 10: Not available with Electronic housing code U, S, T, V, H, M, L, N, D, C, A, B

™ Hastelloy is a Cabot Corporation trademark

™ Galden is a Montefluos trademark

™ Halocarbon is a Halocarbon Products Co. trademark

Standard delivery items (can be differently specified by additional ordering code)

- No drain/vent valve
- General purpose (no electrical certification)
- No meter/display, no mounting bracket, no surge protection
- English manual and labels
- Configuration with kPa and deg. C units
- No test, inspection or material traceability certificates

THE SELECTION OF SUITABLE WETTED PARTS AND FILLING FLUID FOR COMPATIBILITY WITH THE PROCESS MEDIA IS A CUSTOMER'S RESPONSIBILITY, IF NOT OTHERWISE NOTIFIED BEFORE MANUFACTURING.

Contact us

ABB Ltd.

Process Automation

Howard Road
St. Neots
Cambridgeshire PE19 8EU
UK

Tel: +44 (0)1480 475321

Fax: +44 (0)1480 217948

ABB Inc.

Process Automation

125 E. County Line Road
Warminster
PA 18974
USA

Tel: +1 215 674 6000

Fax: +1 215 674 7183

ABB Automation Products GmbH

Process Automation

Schillerstr. 72
32425 Minden
Germany

Tel: +49 551 905 534

Fax: +49 551 905 555

ABB S.p.A.

Process Automation

Via Statale 113
22016 Lenno (CO)
Italy

Tel: +39 0344 58111

Fax: +39 0344 56278

www.abb.com

Note

We reserve the right to make technical changes or modify the contents of this document without prior notice. With regard to purchase orders, the agreed particulars shall prevail. ABB does not accept any responsibility whatsoever for potential errors or possible lack of information in this document.

We reserve all rights in this document and in the subject matter and illustrations contained therein. Any reproduction, disclosure to third parties or utilization of its contents - in whole or in parts - is forbidden without prior written consent of ABB.

Copyright© 2010 ABB

All rights reserved

™ Hastelloy is a Cabot Corporation trademark

™ Monel is an International Nickel Co. trademark

™ DC200 is a Dow Corning Corporation trademark

™ Galden is a Montefluos trademark

™ Halocarbon is a Halocarbon Products Co. trademark