

# Model NAE

## Differential pressure transmitter with remote diaphragm seals

Deltapi N Series  
A complete range of  
pneumatic pressure transmitters

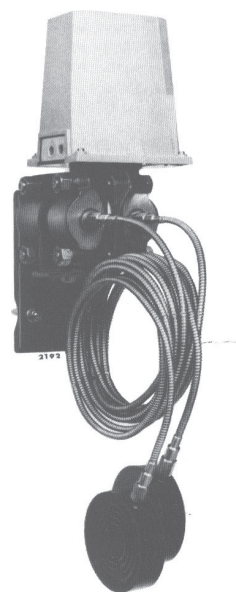

### Introduction

The blind type differential pressure transmitter mod. NAE is used to measure and convert a differential pressure value into a proportional pneumatic signal.

## DESCRIPTION

The instrument works on the force-balance principle and consists of two main units.

**The measuring unit** is formed by two AISI 316 forged halfbodies, measuring capsule and two diaphragm separators completed with capillaries.

A double diaphragm capsule is placed within two halfbodies to relieve the differential pressure transmitted by the two liquid filled separators and capillaries.

The capsule is available in two versions: 2in or 3in diameter diaphragms, filled with a special liquid which can withstand the maximum rated static pressure on either side without damage.

**The transmission unit** converts the differential force applied to the measuring element into a proportional output pneumatic signal.

The output pressure, generated by a flapper nozzle relay, is fed to a feedback bellows with a rising pressure until the bellows force balances that of the measuring element.

**Span value** continuously adjustable by an internal micrometric screw.

**Zero value** adjustable by an external screw.

**Mounting** in a vertical position on 2in diameter pipe by a special bracket.

## OPTIONAL EXTRA FEATURES

**A zero elevation or suppression device** allows to set as a zero of the transmitter a measured variable value different from zero.

Zero suppression value (S) added to the calibrated span must never exceed the upper range limit (M) of measuring capsule:  $S + \text{span} \leq M$  (see table).

**Air filter regulator** can be directly mounted on the transmitter, with or without pressure gauge, and connected with piping and fittings either in stainless steel or copper.

Special versions of air filter regulator and gauges, in stainless steel, are available on request.

## SPECIFICATIONS

The data were obtained from laboratory tests on standard instruments with: AISI 316L bodies; AISI 316L measuring element; silicone oil (DC200) filling; gasket: PTFE; calibration span: 18 kPa - 180 mbar (for 3in diaphragm), 70 kPa - 700 mbar (for 2in diaphragm)

MEASURING CAPSULE (DIAPHRAGM DIA.)	SPAN LIMITS min. and max.	RANGE LIMITS lower and upper (M)	MAXIMUM ZERO SUPPRESSION (S)	MAXIMUM ZERO ELEVATION	STATIC PRESSURE LIMITS Full vacuum and
2 in	40 and 170 kPa 400 and 1700 mbar	-170 and +170 kPa -1700 and +1700 mbar	130 kPa 1300 mbar	170 kPa 1700 mbar	10 MPa 100 bar or flange/fitting rating of the seal whichever is less (*)
3 in	10 and 52 kPa 100 and 520 mbar	-52 and +52 kPa -520 and +520 mbar	42 kPa 420 mbar	52 kPa 520 mbar	

(\*) Equal to Maximum Working pressure as well as overrange limit.

### Air supply

nom. 140 kPa (1.4 bar, 20 psi); min. 125 kPa (1.25 bar, 18 psi); max. 175 kPa (1.75 bar, 25 psi)

### Output signal

20 to 100 kPa/0.2 to 1 bar, 3 to 15 psi or 0.2 to 1 kg/cm<sup>2</sup>

### Static air consumption

350 NI/h

### Maximum output flow

- with rising output pressure: 30 NI/min.
- with falling output pressure: 40 NI/min.

### Accuracy

± 0.5% F.S.D. (typical)

### Differential thermal drift (for ambient temperature variation of 20°C between the separators)

2%/10° C

### Thermal drift (for ambient temperature variation between - 20° C and + 65° C)

- with 2in diaphragm
  - span 40 to 80 kPa (400 to 800 mbar): 0.7%/10°C
  - span 80 to 170 kPa (800 to 1700 mbar): 0.6%/10°C
- with 3in diaphragm
  - span 10 to 52 kPa (100 to 520 mbar): 0.6%/10°C

### - Static pressure effect :

for variation of 3.5 MPa (35 bar): ≤ ± 0.25%

### - Maximum displacement

- with 2in diaphragm: 1 cm<sup>3</sup>
- with 3in diaphragm: 1.5 cm<sup>3</sup>

### Degree of protection in accordance with IEC 529

IP55

### Ambient temperature limits

-40 and + 120°C

### Process temperature limits

Same as fill fluid limits. Refer to table A.  
204°C (400°F) for use with Teflon anti-stick coating.

### Bodies material

AISI 316L

### Seal diaphragm materials

AISI 316L, Hastelloy C 276, Tantalum,  
AISI 316L or Hastelloy C 276 with Teflon anti-stick coating,  
AISI 316L with Teflon coating anti-corrosion and anti-stick

### Measuring capsule material

AISI 316L

### Capsule filling

Silicone oil

### Seal filling / working temperature range

See table "A"

### Cover material

thermoplastic resin

### Surface protections

AISI 316L body and flange: none

### Process connections

- wafer remote seals: 3in ASME150 to 900;  
DN80 DIN ND 10 to 160
- flush diaphragm flanged seal: 3in ASME150 to 900;  
DN80 DIN ND 16 to 160
- extended diaphragm flanged seal: 3in ASME 150-300;  
DN80 DIN ND 16-40

### Pneumatic connections

- Air supply (in figure ref. A): 1/4 in NPT-F
- Output (in figure ref. B): 1/4 in NPT-F

### Pressure gauge

Brass with stainless steel case (all stainless steel on request)  
external diameter 51 mm; 0-200 kPa, 0-2 bar and 0-30 psi  
indication on 82 mm/260° scale.

### Air filter regulator

with copper or stainless steel piping, as specified.  
Die cast aluminium alloy with light grey epoxy finish.

### Net weight (maximum)

23 kg approx

### Packing

expanded polythene box

**TABLE 'A' - FILL FLUIDS CHARACTERISTICS**

FILL FLUIDS (APPLICATION)	OPERATING CONDITIONS				SPECIFICATIONS @ 25°C (77°F)		
	Tmax °C (°F) @ P >of	Pmin mbar abs (psia)	Tmax °C (°F) @ P min	Tmin °C (°F)	Specific gravity	Viscosity Kinematic (cSt)	Thermal Expansions x10 <sup>-3</sup> /°C
Silicone oil DC 200 (General purpose)	200 (390) @ 35 mbar abs	0.7 (0.1)	160 (320)	-40 (-40)	0.93	10	1.08
Silicone oil DC 702 (High temperature)	315 (600) @ atmosphere	0.7 (0.1)	200 (390)	-7 (+20)	1.07	45	0.78
Silicone oil DC 704 (High temperature)	340 (645) @ atmosphere	0.7 (0.1)	230 (445)	20 (70)	1.07	42	0.95
Neobee M-20 (Food-Sanitary)	200 (390) @ atmosphere	130 (1.9)	150 (300)	-18 (0)	0.92	9.8	1.2
Glycerin Water (70%) (Food-Sanitary)	93 (200) @ atmosphere	atmosphere	93 (200)	-7 (+20)	1.08	2.2	0.36
DC 97-9120 PHARMA B GRADE (Food-Sanitary)	200 (390) @ 35 mbar abs	0.7 (0.1)	160 (320)	-40 (-40)	0.96	50	1.04
Inert (Galden) (Oxygen Service)	160 (320) @ atmosphere	0.7 (0.1)	65 (150)	-18 (0)	1.8	4.5	1.1
KTFILL-1 (Paints and specials)	300 (570) @ 400 mbar abs	0.7 (0.1)	160 (320)	-10 (+14)	1	16	0.92

**ORDERING INFORMATION**

Select one character or set of characters from each category and specify complete catalog number. In addition quote the required seal model from one of the enclosed N6 ordering information

**PRODUCT CODE**

abc    de    fg    hi    j    k    lm

BASE MODEL \_\_\_\_\_  
 VERSION \_\_\_\_\_  
 BODY \_\_\_\_\_  
 SPAN LIMITS \_\_\_\_\_  
 CONSTRUCTION \_\_\_\_\_  
 OUTPUT \_\_\_\_\_  
 EXTRAS \_\_\_\_\_

**Code**

**abc** **BASE MODEL** \_\_\_\_\_ **Code**  
 Differential pressure transmitter with remote diaphragm seals **NAE**

**de** **VERSION** \_\_\_\_\_ **Code**  
 Standard **W1**

**fg** **BODY** \_\_\_\_\_ **Code**  
 AISI 316L **11**

**MEASURING ELEMENT**

hi	Diaphragm material	Core material	Filling	Span limits kPa (inH <sub>2</sub> O) (Note 1)	Code
	AISI 316L	AISI 316L	Silicone oil	10 and 52 (40 and 208)	<b>01</b>
	AISI 316L	AISI 316L	Silicone oil	40 and 170 (160 and 682) 10	<b>02</b>

Note 1: Multiply by 10 the value in kPa (MPa) to obtain mbar (bar)

**j** **CONSTRUCTION** \_\_\_\_\_ **Code**  
 Transmitter with remote diaphragm seals (to be quoted separately as N6W, N6E or N6F) **2**

**k** **OUTPUT**

3 to 15 psi	According to ANSI/ISA S 51.1-1979 standard terminology	<b>1</b>
3 to 15 psi with zero elevation device		<b>2</b>
3 to 15 psi with zero suppression device		<b>3</b>
0.2 to 1.0 kg/cm <sup>2</sup>		<b>4</b>
0.2 to 1.0 kg/cm <sup>2</sup> with zero elevation device		<b>5</b>
0.2 to 1.0 kg/cm <sup>2</sup> with zero suppression device		<b>6</b>
20 to 100 kPa / 0.2 to 1 bar		<b>7</b>
20 to 100 kPa / 0.2 to 1 bar with zero elevation device		<b>8</b>
20 to 100 kPa / 0.2 to 1 bar with zero suppression device		<b>9</b>

**EXTRAS**

lm	Identification tag material	Piping material	Air filter regulator	Pressure gauge	Code
	Stainless Steel	--	--	--	<b>02</b>
	Stainless Steel	Stainless Steel	with	--	<b>10</b>
	Stainless Steel	Copper	with	--	<b>11</b>
	Stainless Steel	Stainless Steel	with	with	<b>13</b>
	Stainless Steel	Copper	with	with	<b>14</b>

# N6W WAFER REMOTE SEALS

Select one character or set of characters from each category and specify complete catalog number.

<b>abc</b>	<b>BASE MODEL</b>	<b>Code</b>
	Wafer remote seals	<b>N6W</b>
<b>d</b>	<b>NUMBER OF REMOTE SEALS</b>	
	Two remote seals	<b>2</b>
<b>ef</b>	<b>MOUNTING CONNECTION</b>	
	3in ASME	<b>F3</b>
	DN80, DIN ND 10-40	<b>D3</b>
	DN80, DIN ND 64-160	<b>D8</b>
<b>g</b>	<b>OTHER WETTED MATERIAL (Not diaphragm)</b>	
	Same as diaphragm	<b>0</b>
<b>h</b>	<b>DIAPHRAGM MATERIAL</b>	
	AISI 316L serrated seat finish	<b>2</b>
	AISI 316L smooth seat finish	<b>L</b>
	Hastelloy C 276	<b>3</b>
	Tantalum (max temperature 260°C/500°F) - (NOT VACUUM)	<b>5</b>
	AISI 316L ss with Teflon anti-stick coating	<b>7</b>
	Hastelloy C 276 with Teflon anti-stick coating	<b>8</b>
	AISI 316L ss with Teflon coating anti-corrosion and antistick	<b>A</b>
	(only available with code F3 at position "ef")	
<b>i</b>	<b>EXTENSION LENGTH</b>	
	None	<b>0</b>
<b>j</b>	<b>CAPILLARY - Fill fluid</b>	
	Silicone oil (DC 200)	<b>A</b>
	Silicone oil (DC 702)	<b>C</b>
	Silicone oil (DC 704)	<b>D</b>
	Glycerin/Water	<b>G</b>
	Inert Fluid	<b>P</b>
	KTFILL-1	<b>L</b>
	Neobee M-20	<b>N</b>
	DC97 - 9120 PHARMA B-GRADE	<b>Q</b>
<b>kl</b>	<b>SYSTEM LENGTH m(feet)</b>	
	1 (3)	<b>03</b>
	1.5 (5)	<b>05</b>
	2 (7)	<b>07</b>
	2.5 (8)	<b>08</b>
	3 (10)	<b>10</b>
	3.5 (12)	<b>12</b>
	4 (13)	<b>13</b>
	4.5 (15)	<b>15</b>
	5 (17)	<b>17</b>
	6 (20)	<b>20</b>
	7.5 (25)	<b>25</b>
	9 (30)	<b>30</b>
	10 (35)	<b>35</b>
<b>m</b>	<b>CERTIFICATION</b>	
	None	<b>0</b>
<b>no</b>	<b>OPTIONS</b>	
	None	<b>00</b>

## N6E FLANGED EXTENDED DIAPHRAGM SEALS

Select one character or set of characters from each category and specify complete catalog number.

<b>abc</b>	<b>BASE MODEL</b>		<b>Code</b>
	Flanged extended diaphragm seals		<b>N6E</b>
<b>d</b>	<b>NUMBER OF REMOTE SEALS</b>		
	Two remote seals		<b>2</b>
<b>ef</b>	<b>MOUNTING CONNECTION</b>	<b>Material</b>	
	3in ASME CL150	Carbon steel	<b>K3</b>
	3in ASME CL150	AISI 316 ss	<b>S3</b>
	3in ASME CL300	Carbon steel	<b>L3</b>
	3in ASME CL300	AISI 316 ss	<b>36</b>
	DN80, DIN ND 16	Carbon steel	<b>4C</b>
	DN80, DIN ND 16	AISI 316 ss	<b>4M</b>
	DN80, DIN ND 40	Carbon steel	<b>4D</b>
	DN80, DIN ND 40	AISI 316 ss	<b>4N</b>
<b>g</b>	<b>OTHER WETTED MATERIAL (Not diaphragm)</b>		
	AISI 316L ss		<b>2</b>
	Hastelloy C (only available with diaphragm material code 3, 8 and A at position "h")		<b>3</b>
<b>h</b>	<b>DIAPHRAGM MATERIAL</b>		
	AISI 316L ss		<b>2</b>
	Hastelloy C 276		<b>3</b>
	AISI 316L ss with Teflon anti-stick coating	(only available with 3in ANSI CL 150/300 connection, code K3,S3,L3,36 at position "ef")	<b>7</b>
	Hastelloy C 276 with Teflon anti-stick coating		<b>8</b>
	AISI 316L ss with Teflon coating anti-corrosion and antistick		<b>A</b>
<b>i</b>	<b>EXTENSION LENGTH</b>		
	2in		<b>2</b>
	4in		<b>4</b>
	6in		<b>6</b>
<b>j</b>	<b>CAPILLARY - Fill fluid</b>		
	Silicone oil (DC 200)		<b>A</b>
	Silicone oil (DC 702)		<b>C</b>
	Silicone oil (DC 704)		<b>D</b>
	Glycerin/Water		<b>G</b>
	Inert Fluid		<b>P</b>
	KTFILL-1		<b>L</b>
	Neobee M-20		<b>N</b>
<b>kl</b>	<b>SYSTEM LENGTH m(feet)</b>		
	1 (3)		<b>03</b>
	1.5 (5)		<b>05</b>
	2 (7)		<b>07</b>
	2.5 (8)		<b>08</b>
	3 (10)		<b>10</b>
	3.5 (12)		<b>12</b>
	4 (13)		<b>13</b>
	4.5 (15)		<b>15</b>
	5 (17)		<b>17</b>
	6 (20)		<b>20</b>
	7.5 (25)		<b>25</b>
	9 (30)		<b>30</b>
	10 (35)		<b>35</b>
<b>m</b>	<b>CERTIFICATION</b>		
	None		<b>0</b>
<b>no</b>	<b>OPTIONS</b>		
	None		<b>00</b>

# N6F FLANGED FLUSH DIAPHRAGM SEALS

Select one character or set of characters from each category and specify complete catalog number.

<b>abc</b>	<b>BASE MODEL</b>		<b>Code</b>
	Flanged flush diaphragm seals		<b>N6F</b>
<b>d</b>	<b>NUMBER OF REMOTE SEALS</b>		
	Two remote seals		<b>2</b>
<b>ef</b>	<b>MOUNTING CONNECTION</b>	<b>Material</b>	
	3in ASME CL150	Carbon steel	<b>K3</b>
	3in ASME CL150	AISI 316 ss	<b>S3</b>
	3in ASME CL300	Carbon steel	<b>L3</b>
	3in ASME CL300	AISI 316 ss	<b>36</b>
	3in ASME CL600	Carbon steel	<b>37</b>
	3in ASME CL600	AISI 316 ss	<b>38</b>
	3in ASME CL900	Carbon steel	<b>39</b>
	3in ASME CL900	AISI 316 ss	<b>3A</b>
	DN80, DIN ND 16	Carbon steel	<b>4C</b>
	DN80, DIN ND 16	AISI 316 ss	<b>4M</b>
	DN80, DIN ND 40	Carbon steel	<b>4D</b>
	DN80, DIN ND 40	AISI 316 ss	<b>4N</b>
	DN80, DIN ND 64	Carbon steel	<b>4E</b>
	DN80, DIN ND 64	AISI 316 ss	<b>4F</b>
	DN80, DIN ND 100	Carbon steel	<b>4H</b>
	DN80, DIN ND 100	AISI 316 ss	<b>4G</b>
	DN80, DIN ND 160	Carbon steel	<b>4K</b>
	DN80, DIN ND 160	AISI 316 ss	<b>4L</b>
<b>g</b>	<b>OTHER WETTED MATERIAL (Not diaphragm)</b>		
	Same as diaphragm		<b>0</b>
<b>h</b>	<b>DIAPHRAGM MATERIAL</b>		
	AISI 316L serrated seat finish		<b>2</b>
	AISI 316L smooth seat finish		<b>L</b>
	Hastelloy C 276		<b>3</b>
	Tantalum (max temperature 260°C/500°F) - (NOT VACUUM)		<b>5</b>
	AISI 316L ss with Teflon anti-stick coating	(only available with 3in connection code	<b>7</b>
	Hastelloy C 276 with Teflon anti-stick coating	K3,S3,L3,36,37,38,39,3A at position "ef")	<b>8</b>
	AISI 316L ss with Teflon coating anti-corrosion and antistick		<b>A</b>
<b>i</b>	<b>EXTENSION LENGTH</b>		
	None		<b>0</b>
<b>j</b>	<b>CAPILLARY - Fill fluid</b>		
	Silicone oil (DC 200)		<b>A</b>
	Silicone oil (DC 702)		<b>C</b>
	Silicone oil (DC 704)		<b>D</b>
	Glycerin/Water		<b>G</b>
	Inert Fluid		<b>P</b>
	KTFILL-1		<b>L</b>
	Neobee M-20		<b>N</b>
	DC97 - 9120 PHARMA B-GRADE		<b>Q</b>
<b>kl</b>	<b>SYSTEM LENGTH m(feet)</b>		
	1 (3)		<b>03</b>
	1.5 (5)		<b>05</b>
	2 (7)		<b>07</b>
	2.5 (8)		<b>08</b>
	3 (10)		<b>10</b>
	3.5 (12)		<b>12</b>
	4 (13)		<b>13</b>
	4.5 (15)		<b>15</b>
	5 (17)		<b>17</b>
	6 (20)		<b>20</b>
	7.5 (25)		<b>25</b>
	9 (30)		<b>30</b>
	10 (35)		<b>35</b>
<b>m</b>	<b>CERTIFICATION</b>		
	None		<b>0</b>
<b>no</b>	<b>OPTIONS</b>		
	None		<b>00</b>

Compliance to NACE class II bolting, according to specification MR0175, latest revision

# MOUNTING DIMENSIONS

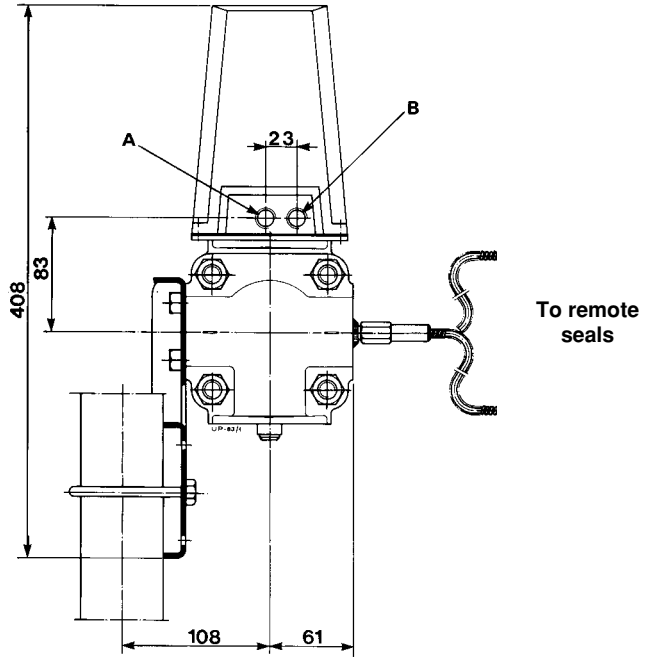
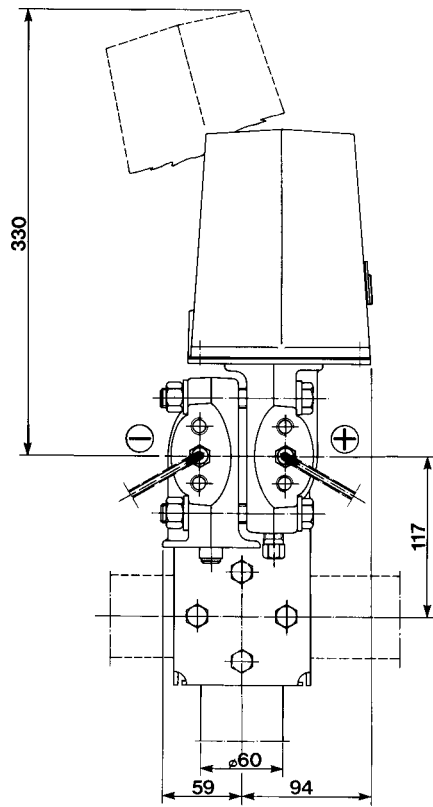

• **N6W Remote wafer seals**

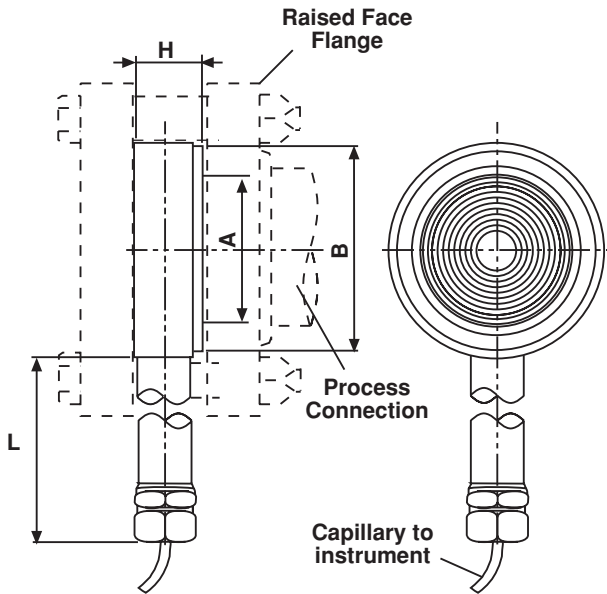

SIZE	DIMENSIONS mm (in)			
	A (dia)	B dia)	H	L
3 in	89 (3.5)	127 (5)	23 (0.9)	139.7 (5.5)
DN 80	89 (3.5)	138 (5.43)	23 (0.9)	139.7 (5.5)

**Wafer seal maximum working pressure:**  
 16 MPa, 160 bar, 2320 psi but not greater than the backup flange rating (not supplied)

• N6F Remote flanged flush diaphragm seals

• N6E Remote flanged extended diaphragm seals

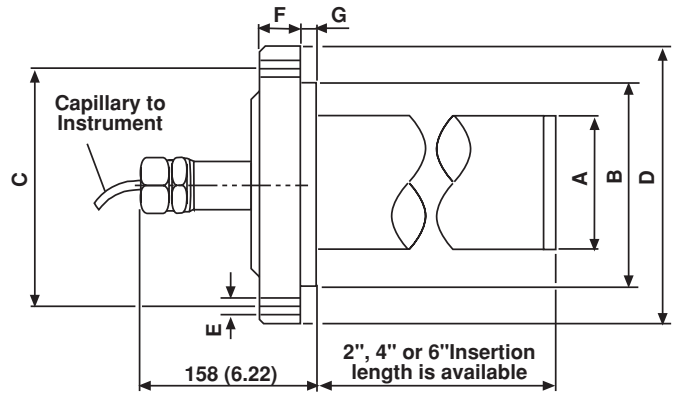
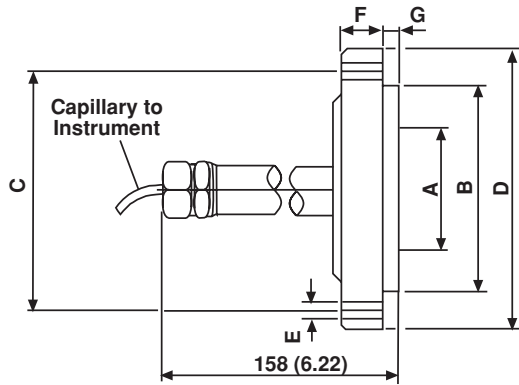

SIZE/RATING	A (dia)		DIMENSIONS mm (in)						N° of holes
	flush	extended	B (dia)	C (dia)	D (dia)	E (dia)	F	G	
3in ASME CL 150	89 (3.5)	72 (2.83)	127 (5)	152.5 (6)	190.5 (7.5)	20 (0.79)	24 (0.94)	9.5 (0.37)	4
3in ASME CL 300	89 (3.5)	72 (2.83)	127 (5)	168.5 (6.63)	210 (8.26)	22 (0.86)	28.5 (1.12)	9.5 (0.37)	8
3in ASME CL 600	89 (3.5)		127 (5)	168.5 (6.63)	210 (8.26)	22 (0.86)	32 (1.26)	9.5 (0.37)	8
3in ASME CL 900	89 (3.5)		127 (5)	190.5 (7.5)	241 (9.48)	26 (1.02)	38.5 (1.51)	9.5 (0.37)	8
DN80 DIN ND16	89 (3.5)	72 (2.83)	138 (5.43)	160 (6.3)	200 (7.87)	18 (0.71)	20 (0.79)	9.5 (0.37)	8
DN80 DIN ND40	89 (3.5)	72 (2.83)	138 (5.43)	160 (6.3)	200 (7.87)	18 (0.71)	24 (0.94)	9.5 (0.37)	8
DN80 DIN ND64	89 (3.5)		138 (5.43)	170 (6.7)	215 (8.46)	22 (0.86)	28 (1.1)	9.5 (0.37)	8
DN80 DIN ND100	89 (3.5)		138 (5.43)	180 (7.08)	230 (9.05)	26 (1.02)	32 (1.26)	9.5 (0.37)	8
DN80 DIN ND160	89 (3.5)		138 (5.43)	180 (7.08)	230 (9.05)	26 (1.02)	36 (1.42)	9.5 (0.37)	8

**Flanged seal maximum working pressure:**

- ASME CL 150: 2 MPa, 20 bar, 290 psi
- ASME CL 300: 5 MPa, 50 bar, 725 psi
- ASME CL 600: 10 MPa, 100 bar, 1450 psi
- ASME CL 900: 16 MPa, 160 bar, 2320 psi
- DIN ND 16: 1.6 MPa, 16 bar, 230 psi
- DIN ND 40: 4 MPa, 40 bar, 580 psi
- DIN ND 64: 6.4 MPa, 64 bar, 930 psi
- DIN ND 100: 10 MPa, 100 bar, 1450 psi
- DIN ND 160: 16 MPa, 160 bar, 2320 psi

# Contact us

## **ABB Ltd.**

### **Process Automation**

Howard Road  
St. Neots  
Cambridgeshire PE19 8EU  
UK  
Tel: +44 (0)1480 475321  
Fax: +44 (0)1480 217948

## **ABB Inc.**

### **Process Automation**

125 E. County Line Road  
Warminster  
PA 18974  
USA  
Tel: +1 215 674 6000  
Fax: +1 215 674 7183

## **ABB Automation Products GmbH**

### **Process Automation**

Schillerstr. 72  
32425 Minden  
Germany  
Tel: +49 551 905 534  
Fax: +49 551 905 555

## **ABB S.p.A.**

### **Process Automation**

Via Statale 113  
22016 Lenno (CO)  
Italy  
Tel: +39 0344 58111  
Fax: +39 0344 56278

[www.abb.com](http://www.abb.com)

## Note

We reserve the right to make technical changes or modify the contents of this document without prior notice. With regard to purchase orders, the agreed particulars shall prevail. ABB does not accept any responsibility whatsoever for potential errors or possible lack of information in this document.

We reserve all rights in this document and in the subject matter and illustrations contained therein. Any reproduction, disclosure to third parties or utilization of its contents - in whole or in parts - is forbidden without prior written consent of ABB.

Copyright© 2011 ABB  
All rights reserved

3KXP900204R1001