

Model 264DR Differential
Models 264PR and 264HR Gauge
Models 264VR and 264NR Absolute
with remote seal(s)

- **Base accuracy : $\pm 0.075\%$**
- **Span limits**
 - 0.2 to 60000kPa; 0.8inH₂O to 8700psi
 - 0.54 to 16000kPa abs; 4mmHg to 2320psia
- **Reliable sensing system coupled with very latest digital technologies**
- **Comprehensive sensor choice**
 - optimize in-use total performance and stability
- **5-year stability**
- **Flexible configuration facilities**
 - provided locally via local keys combined with LCD indicator or via hand held terminal or PC configuration platform
- **Multiple protocol availability**
 - provides integration with HART®, PROFIBUS PA and FOUNDATION Fieldbus platforms offering interchangeability and transmitter upgrade capabilities
- **Broad selection of variants, options fill fluids and wetted materials**
 - allows total flexibility maximizing cost-effective aspect, also providing applications with critical process media at extended temperature range
- **PED compliance to sound engineering practice (SEP)**



ABB 2600T Series
Engineered solutions
for all applications

2600T Pressure Transmitters

Model 264DR, 264PR, 264HR, 264VR, 264NR

SS/264XR_7

General Description

Models detailed in this data sheet apply for those transmitters which include one or two remote seal(s) connected via a capillary to the transmitter sensor. Depending on the selected ordering code the following models are available:

- model 264DR which allows a differential measurement using either two remote seals of same type and size or one remote seal (on positive or negative side) and a standard threaded connection direct 1/4 – 18 NPT on flange or 1/2 – 14 NPT through adapter, for the wet or dry leg on the side opposite to seal.
- models 264PR or 264VR allowing gauge or absolute measurement respectively with the reference side at atmosphere or at vacuum. The other side which can be the positive or negative (high or low pressure side) features the required remote seal.

Model 264HR or 264NR have the remote seal on the positive side and the user can select the suitable code for having the reference at atmospheric or vacuum pressure respectively for gauge or absolute measure.

The following table list the types of standard seal which can be combined with 264xR transmitters (the mnemonic is used as reference in the compatibility table of page 3).

Refer to seal data sheet for all data and details relevant to seal element.

All following specification data apply for identical characteristics of the two sides when the transmitter is differential with two seals.

Model	Seal type	Size	Mnemonic
S264W	Wafer Wafer (food)	1 1/2in / DN40 2in / DN50 3in / DN80	P1.5 P2 P3
S264C	Chemical tee flanged	3in	P3
S264A S264E S264G S264R	Flanged flush diaphragm (also Ring Joint)	1-1/2in (ASME RJ only) 2in / DN50 / A50 3-4in / DN80-100 A80-100	P1.5 P2 P3
	Flanged extended diaphragm	2in / DN50 3in / DN80 4in / DN100	E2 E3 P3
S264U	Union	1 1/2in	Z1.5
S264T	Threaded off-line	2 1/2in	T2.5
S264M	Flanged off-line	2 1/2in	T2.5
S264S	Union nut Triclamp Cherry Burrel Sanitary, Aseptic	2in / F50 3in / F80 4in	S2 S3 S3
S264B	Button	1in	B1
S264P	Urea service flanged	1 1/2in 2 1/2in	U1.5 U2.5

Functional Specifications

Range and span limits

– models 264DR/264PR/264VR

Sensor Code	Upper Range Limit (URL)	Lower Range Limit (LRL)			Minimum span
		264DR differential measure	264PR gauge measure	264VR absolute measure	
B	4kPa 40mbar 16inH ₂ O	-4kPa -40mbar -16inH ₂ O			0.2kPa 2mbar 0.8inH ₂ O
E	16kPa 160mbar 64inH ₂ O	-16kPa -160mbar -64inH ₂ O	-16kPa -160mbar -64inH ₂ O	0.07kPa abs (\$) 0.7mbar abs (\$) 0.5mmHg (\$)	0.54kPa 5.4mbar 2.16inH ₂ O
F	40kPa 400mbar 160inH ₂ O	-40kPa -400mbar -160inH ₂ O	-40kPa -400mbar -160inH ₂ O	0.07kPa abs (\$) 0.7mbar abs (\$) 0.5mmHg (\$)	0.67kPa 6.7mbar 2.67inH ₂ O
G	65kPa 650mbar 260inH ₂ O	-65kPa -650mbar -260inH ₂ O	-65kPa -650mbar -260inH ₂ O	0.07kPa abs (\$) 0.7mbar abs (\$) 0.5mmHg (\$)	1.1kPa 11mbar 4.35inH ₂ O
H	160kPa 1600mbar 642inH ₂ O	-160kPa -1600mbar -642inH ₂ O	0.07kPa abs (\$) 0.7mbar abs (\$) 0.5mmHg (\$)	0.07kPa abs (\$) 0.7mbar abs (\$) 0.5mmHg (\$)	2.67kPa 26.7mbar 10.7inH ₂ O
M	600kPa 6bar 87psi	-600kPa -6bar -87psi	0.07kPa abs (\$) 0.7mbar abs (\$) 0.5mmHg (\$)	0.07kPa abs (\$) 0.7mbar abs (\$) 0.5mmHg (\$)	10kPa 0.1bar 1.45psi
P	2400kPa 24bar 348psi	-2400kPa -24bar -348psi	0.07kPa abs (\$) 0.7mbar abs (\$) 0.5mmHg (\$)	0.07kPa abs (\$) 0.7mbar abs (\$) 0.5mmHg (\$)	40kPa 0.4bar 5.8psi
Q	8000kPa 80bar 1160psi	-8000kPa -80bar -1160psi	0.07kPa abs (\$) 0.7mbar abs (\$) 0.5mmHg (\$)	0.07kPa abs (\$) 0.7mbar abs (\$) 0.5mmHg (\$)	134kPa 1.34bar 19.4psi
S	16000kPa 160bar 2320psi	-16000kPa -160bar -2320psi	0.07kPa abs (\$) 0.7mbar abs (\$) 0.5mmHg (\$)	0.07kPa abs (\$) 0.7mbar abs (\$) 0.5mmHg (\$)	267kPa 2.67bar 38.7psi

2600T Pressure Transmitters

Model 264DR, 264PR, 264HR, 264VR, 264NR

SS/264XR_7

- models 264HR/NR

Sensor Code	Upper Range Limit (URL)	Lower Range Limit (LRL) for 264HR	Minimum Span	
			264HR	264NR
G	65kPa 650mbar 260inH ₂ O	-65kPa -650mbar -260inH ₂ O	1.1kPa 11mbar 4.35inH ₂ O	1.1kPa 11mbar 8mmHg
H	160kPa 1600mbar 642inH ₂ O	0.07kPa abs (§) 0.7mbar abs (§) 0.5mmHg (§)	2.67kPa 26.7mbar 10.7inH ₂ O	2.67kPa 26.7mbar 20mmHg
M	600kPa 6bar 87psi	0.07kPa abs (§) 0.7mbar abs (§) 0.5mmHg (§)	10kPa 0.1bar 1.45psi	10kPa 0.1bar 1.45psi
P	2400kPa 24bar 348psi	0.07kPa abs (§) 0.7mbar abs (§) 0.5mmHg (§)	40kPa 0.4bar 5.8psi	40kPa 0.4bar 5.8psi
Q	8000kPa 80bar 1160psi	0.07kPa abs (§) 0.7mbar abs (§) 0.5mmHg (§)	134kPa 1.34bar 19.4psi	134kPa 1.34bar 19.4psi
S	16000kPa 160bar 2320psi	0.07kPa abs (§) 0.7mbar abs (§) 0.5mmHg (§)	267kPa 2.67bar 38.7psi	267kPa 2.67bar 38.7psi
V	60000kPa 600bar 8700psi	0.07kPa abs (§) 0.7mbar abs (§) 0.5mmHg (§)	2000kPa 20bar 290psi	

Lower Range Limit (LRL) for 264NR is 0.07kPa abs, 0.7mbar abs, 0.5mmHg for all ranges

(§) Lower Range Limit is 0.135kPa abs, 1.35mbar abs, 1mmHg for inert Galden or 0.4kPa abs, 4mbar abs, 3mmHg for inert Halocarbon.

Span limits

Maximum span = URL
(can be further adjusted up to ± URL (TD = 0.5) for differential models, within the range limits)

IT IS RECOMMENDED TO SELECT THE TRANSMITTER SENSOR CODE PROVIDING THE TURNDOWN VALUE AS LOWEST AS POSSIBLE TO OPTIMIZE PERFORMANCE CHARACTERISTICS.

Zero suppression and elevation

Zero and span can be adjusted to any value within the range limits detailed in the table as long as:

- calibrated span ≥ minimum span

Damping

Selectable time constant : 0, 0.25, 0.5, 1, 2, 4, 8 or 16s.
This is in addition to sensor response time

Turn on time

Operation within specification in less than 1s with minimum damping.

Insulation resistance

> 100MΩ at 1000VDC (terminals to earth)

Sensor Code	Compatibility (allowed seal types with maximum capillary length (m) in brackets) versus measurement configuration		
	Differential (two seals)	gauge and differential (one seal)	absolute (one seal)
B	P3 (1.5) E3 (1•) T2.5 (1•) S3 (1.5•)		
E	P3 (3) E3 (2•), T2.5 (2•), S3 (3•)	P3 (1) S3 (1)	P3 (1) S3 (1)
F-G	P2 (3), P3 (6), E2 (2), E3 (4), T2,5 (3) U2.5 (3), S2 (1•), S3 (6)	P2 (2), P3 (4), E3 (3), T2,5 (2) U2.5 (3), S3 (4)	P2 (2), P3 (3), E3 (3), T2,5 (2) U2.5 (3), S3 (3)
H	P1.5 (4), P2 (8), P3 (8), E2 (6), E3 (6) T2.5 (6), U2.5 (6), S2 (3), S3 (10)	P1.5 (3), P2 (6), P3 (10), E2 (4), E3 (8), Z1.5 (3), T2.5 (6), U2.5 (6), S2 (2), S3 (10)	P1.5 (3), P2 (5), P3 (8), E2 (3), E3 (6) T2.5 (5), U2.5 (5), S2 (2), S3 (8)
M	P1.5 (5), P2 (8), P3 (10), E2 (6), E3 (8), T2.5 (6), U2.5 (6), S2 (6), S3 (10)	P1.5 (5), P2 (8), P3 (10), E2 (6), E3 (8), Z1.5 (5), T2.5 (6), U1.5 (5), U2.5 (6), S2 (6), S3 (10)	P1.5 (4), P2 (6), P3 (8), E2 (5), E3 (6), T2.5 (5), U1.5 (4), U2.5 (5), S2 (5), S3 (8)
P	P1.5 (5), P2 (8), P3 (10), E2 (6), E3 (8), T2.5 (6), U2.5 (6), S2 (6), S3 (10)	P1.5 (5), P2 (8), P3 (10), E2 (6), E3 (8), Z1.5 (5), T2.5 (6), U1.5 (5), U2.5 (6), S2 (6), S3 (10)	P1.5 (4), P2 (6), P3 (8), E2 (5), E3 (6), T2.5 (5), U1.5 (4), U2.5 (5), S2 (5), S3 (8)
Q	P1.5 (5), P2 (8), P3 (10), E2 (6), E3 (8), T2.5 (6), U2.5 (6), S2 (6), S3 (10)	P1.5 (5), P2 (8), P3 (10), E2 (6), E3 (8), B1 (3•) Z1.5 (5), T2.5 (6), U1.5 (5), U2.5 (6), S2 (6), S3 (10)	P1.5 (4), P2 (6), P3 (8), E2 (5), E3 (6), T2.5 (5), U1.5 (4), U2.5 (5), S2 (5), S3 (8)
S	P1.5 (5), P2 (8), P3 (10), T2.5 (6), U2.5 (6)	P1.5 (5), P2 (8), P3 (10), Z1.5 (5), T2.5 (6), U1.5 (5), U2.5 (6), B1 (3•)	P1.5 (4), P2 (6), P3 (8), T2.5 (5), U1.5 (4), U2.5 (5)
V		P1.5 (5), P2 (8), P3 (10), T2.5 (6), B1 (3), U1.5 (5), U2.5 (6)	

The combinations sensor code/seal type marked (•) modify the base accuracy rating and static pressure effect; refer to performance specifications. Although the above table defines capillary length, for some types of seal combined to the sensor, care should be taken of the maximum working pressure of the used seal which can limit the range.

Refer to ABB for data related to application of capillary lengths greater than those specified in above table.

Operative limits

Temperature limits °C (°F) :

Ambient (is the operating temperature)

Filling	Models 264DR/PR/VR		Models 264HR/NR	Model 264HR
	Sensors F to S	Sensors B, E	Sensors G to S	Sensor V
Silicone oil DC 200	-40 and +85 (-40 and +185)	-25 and +85 (-13 and +185)	-40 and +85 (-40 and +185)	-40 and +85 (-40 and +185)
Inert Galden	-20 and +85 (-4 and +185)	-10 and +85 (+14 and +185)	-20 and +85 (-4 and +185)	
Inert Halocarbon	-20 and +85 (-4 and +185)	-10 and +85 (+14 and +185)	-20 and +85 (-4 and +185)	

Lower ambient limit for LCD indicators: -20°C (-4°F)

Upper ambient limit for LCD indicators: +70°C (+158°F)

Note : For Hazardous Atmosphere applications see the temperature range specified on the certificate/approval relevant to the aimed type of protection

Process

Lower limit (side without seal for 264DR only)

- refer to lower ambient limits; -20°C (-4°F) for Viton gasket

Upper limit (side without seal for 264DR only)

- Silicone oil: 121°C (250°F) (1)

- Inert fluid: 100°C (212°F) (2)

(1) 100°C (212°F) for application below atmospheric pressure

(2) 65°C (150°F) for application below atmospheric pressure

The following table show characteristics of capillary/seal fill fluids when used in transmitters with remote seal.

FILL FLUIDS (APPLICATION)	OPERATING CONDITIONS			
	Tmax @ Pabs>of	Pmin mbar abs (psia)	Tmax @ P min	Tmin
Silicone oil-DC200 (General purpose)	200 (390) @ 35mbar	0.7 (0.01)	160 (320)	-40 (-40)
Silicone oil-AN140 (High temperature)	380 (716) @ 1bar	0.7 (0.01)	300 (572)	-5 (+23)
Silicone Polymer-SylthermXLT (Low temperature)	100 (212) @ 110mbar	2 (0.03)	20 (68)	-100 (-148)
Vegetable oil-Neobee M-20 (Food-Sanitary) FDA	200 (390) @ 1bar	130 (1.9)	150 (300)	-18 (0)
Glycerin Water (70%) (Food-Sanitary) FDA	93 (200) @ 1bar	1000 (14.5)	93 (200)	-7 (+20)
Mineral oil-MARCOL 82 (Food-Sanitary) FDA	200 (390) @ 200mbar	33 (0.5)	40 (104)	-40 (-40)
Inert - Galden (Oxygen Service)	160 (320) @ 1bar	2 (0.03)	70 (158)	-20 (-4)
Inert - Halocarbon 4.2 (Oxygen Service)	180 (356) @ 400mbar	4 (0.06)	70 (158)	-20 (-4)

Fill fluids with FDA are defined as food fills and are Generally Recognized As Safe (GRAS) by the US Food and Drug Administration (FDA).

REFER ALSO TO S264 DATA SHEET FOR FURTHER LIMITATION DUE TO SEAL VARIANTS.

Storage

Lower limit: -50°C (-58°F); -40°C (-40°F) for LCD indicators

Upper limit: +85°C (+185°F)

Pressure limits

Refer to seal data sheet for maximum working pressure related to the used remote seal.

Overpressure limits (without damage to the transmitter)

0.07kPa abs, 0.7mbar abs, 0.01psia (0.135kPa abs, 1.35mbar abs, 1mmHg for inert Galden or 0.4kPa abs, 4mbar abs, 3mmHg for inert Halocarbon) to transmitter sensor limit or flange rating of seal, whichever is less:

- 21MPa, 210bar, 3045psi for models 264DR, 264PR and 264VR (except 7MPa, 70bar, 1015psi for sensor code B and 16MPa, 160bar, 2320psi for sensor code E)

- 21MPa, 210bar, 3045psi for models 264HR/NR sensors P,Q,S

- 14MPa, 140bar, 2030psi for models 264HR/NR sensors G,H,M

- 90MPa, 900bar, 13050psi for model 264HR sensor V.

Static pressure

Transmitters for differential pressure model 264DR operates within specifications between the following limits:

- 1.3kPa abs, 13mbar abs, 0.2psia and 21MPa, 210bar, 3045psi (except 7MPa, 70bar, 1015psi for sensor code B and 16MPa, 160bar, 2320psi for sensor code E).

- 0.07kPa abs, 0.7mbar abs, 0.1psia and 21MPa, 210bar, 3045psi (except 7MPa, 70bar, 1015psi for sensor code B and 16MPa, 160bar, 2320 psi for sensor code E) or flange rating of seal whichever is less, using two remote seals on both transmitter side.

Proof pressure

The transmitter can be exposed without leaking to line pressure of up to

- 28MPa, 280bar, 4000psi for model 264DR, 264PR and 264VR and for sensor codes G,H,M of models 264HR and 264NR

- 40MPa, 400bar, 5900 psi for sensor codes P,Q,S of models 264HR/NR

- 90MPa, 900bar, 13050 psi for sensor code V of model 264HR

or two times the flange rating of seal, whichever is less

Meet ANSI/ISA-S 82.03 hydrostatic test requirements.

Environmental limits

Electromagnetic compatibility (EMC)

Comply with EN 61000-6-3 for emission and EN 61000-6-2 for immunity requirements and test;

Radiated electromagnetic immunity level: (according to IEC 1000-4-3, EN61000-4-3)	30V/m
Conducted electromagnetic immunity level : (according to IEC 1000-4-6, EN 61000-4-6)	30V
Surge immunity level (with surge protector): (according to IEC 1000-4-5 EN 61000-4-5)	4kV
Fast transient (Burst) immunity level: (according to IEC 1000-4-4 EN 61000-4-4)	4kV

Pressure equipment directive (PED)

Comply with 97/23/EEC following sound engineering practice (SEP).

Humidity

Relative humidity:	up to 100% annual average
Condensing, icing:	admissible

Vibration resistance

Accelerations up to 2g at frequency up to 1000Hz
(according to IEC 60068-2-6)

Shock resistance (according to IEC 60068-2-27)

Acceleration:	50g
Duration:	11ms

Wet and dust-laden atmospheres

The transmitter is dust and sand tight and protected against immersion effects as defined by EN 60529 (1989) to IP 67 (IP 68 on request) or by NEMA to 4X or by JIS to C0920. IP65 with Harting Han connector.

Hazardous atmospheres

With or without output meter/integral display

- COMBINED ATEX (Intrinsic safety and flameproof), FM and CSA ZELM approval. See below detailed classifications.
- COMBINED INTRINSIC SAFETY and FLAMEPROOF/EUROPE: ATEX/ZELM approval
 - II 1 GD T50°C, EEx ia IIC T6 (-40°C ≤ Ta ≤ +40°C) T95°C, EEx ia IIC T4 (-40°C ≤ Ta ≤ +85°C)
 - II 1/2 GD T85°C, EEx d IIC T6 (-40°C ≤ Ta ≤ +75°C)
- INTRINSIC SAFETY/EUROPE: ATEX/ZELM approval
 - II 1 GD T50°C, EEx ia IIC T6 (-40°C ≤ Ta ≤ +40°C) T95°C, EEx ia IIC T4 (-40°C ≤ Ta ≤ +85°C)
- TYPE "N"/EUROPE: ATEX/ZELM type examination (for HART)
 - II 3 GD T50°C, EEx nL IIC T6 (-40°C ≤ Ta ≤ +40°C) T95°C, EEx nL IIC T4 (-40°C ≤ Ta ≤ +85°C)
- FLAMEPROOF/EUROPE: ATEX/CESI approval
 - II 1/2 GD T85°C, EEx d IIC T6 (-40°C ≤ Ta ≤ +75°C)
- CANADIAN STANDARDS ASSOCIATION and FACTORY MUTUAL:
 - Explosionproof: Class I, Div. 1, Groups A, B, C, D
 - Dust ignitionproof : Class II, Div. 1, Groups E, F, G
 - Suitable for : Class II, Div. 2, Groups F, G; Class III, Div. 1, 2
 - Nonincendive: Class I, Div. 2, Groups A, B, C, D
 - Intrinsically safe: Class I, II, III, Div. 1, Groups A, B, C, D, E, F, G AEx ia IIC T6/T4, Zone 0 (FM)
- STANDARDS AUSTRALIA (SAA): TS Approval
 - Intrinsically safe Ex ia IIC T4/T5 (-20°C ≤ Ta ≤ +80°C) only HART
 - No sparking Ex n IIC T4/T6 (-20°C ≤ Ta ≤ +80°C) only HART
 - Flameproof Ex d IIC T4/T6 (-20°C ≤ Ta ≤ +80°C)
 - Dust ignitionproof DIP A21 Ta T6 (-20°C ≤ Ta ≤ +80°C)
- INTRINSIC SAFETY/CHINA
 - NEPSI approval Ex ia IIC T4-T6
- FLAMEPROOF/CHINA
 - NEPSI approval Ex d IIC T6
- GOST (Russia), GOST (Kazakhstan), Inmetro (Brazil) based on ATEX

Electrical Characteristics and Options

HART digital communication and 4 to 20mA output

Power Supply

The transmitter operates from 10.5 to 42VDC with no load and is protected against reverse polarity connection (additional load allows operations over 42VDC).

For EEx ia and other intrinsically safe approval power supply must not exceed 30VDC.

Ripple

20mV max on a 250Ω load as per HART specifications

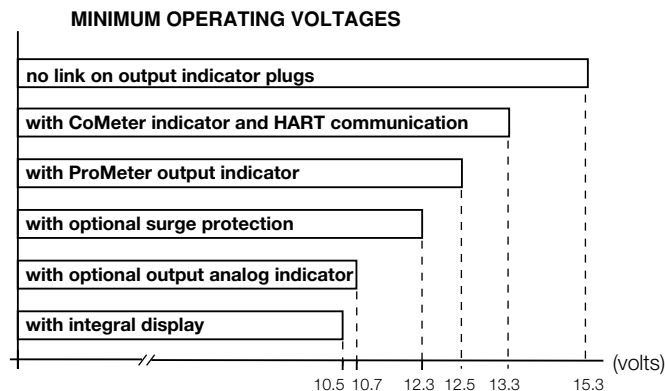

Load limitations

4 to 20mA and HART total loop resistance :

$$R(k\Omega) = \frac{\text{Supply voltage} - \text{min. operating voltage (VDC)}}{22.5}$$

A minimum of 250Ω is required for HART communication.

Optional indicators

Output meter

CoMeter and Prometer LCD:

5-digit (±99999 counts) programmable with 7.6mm. high (3in), 7-segment numeric characters plus sign and digital point for digital indication of output value in percentage, current or engineer unit;

10-segment bargraph display (10% per segment) for analog indication of output in percentage;

7-digit with 6mm. high (2.3in), 14-segment alphanumeric characters, for engineer units and configuration display

Analog : 36mm (1.4in) scale on 90°.

Integral display

LCD, 15 lines x 56 column dot matrix providing 2 lines indication as

- top: 5-digit (numeric) plus sign or 7-digit alphanumeric
- bottom: 7-digit alphanumeric

and additional 50-segment bargraph for indication of analog output in percentage.

User-definable matrix display mode with HART communication:

- process variable in pressure unit or
- output signal as percentage, current or engineering units

Display also indicates in/out transfer function, static pressure, sensor temperature and diagnostic messages and provides configuration facilities.

Optional surge protection

Up to 4kV

- voltage 1.2 μs rise time / 50 μs delay time to half value
- current 8 μs rise time / 20 μs delay time to half value

Output signal

Two-wire 4 to 20mA, user-selectable for linear or square root output, power of ³/₂ or ⁵/₂, 5th order or two 2nd order switching point selectable programmable polynomial output.

HART® communication provides digital process variable (% , mA or engineering units) superimposed on 4 to 20mA signal, with protocol based on Bell 202 FSK standard.

Output current limits (to NAMUR standard)

Overload condition

- Lower limit: 3.8mA
- Upper limit: 20.5mA

Transmitter failure mode (to NAMUR standard)

The output signal can be user-selected to a value of 3.7 or 22mA on gross transmitter failure condition, detected by self-diagnostics.

In case of CPU failure the output is driven <3.7mA or >22mA.

PROFIBUS PA output

Device type

Pressure transmitter compliant to Profiles 3.0 Class A & B; ident. number 052B HEX.

Power supply

The transmitter operates from 9 to 32VDC, polarity independent.

For EEx ia approval power supply must not exceed 17.5VDC. Intrinsic safety installation according to FISCO model.

Current consumption

operating (quiescent): 10.5mA

fault current limiting: 20mA max.

Output signal

Physical layer in compliance to IEC 1158-2/EN 61158-2 with transmission to Manchester II modulation, at 31.25kbit/sec.

Output interface

PROFIBUS PA communication according to Profibus DP50170 Part 2/ DIN 19245 part 1-3.

Output update time

25ms

Function blocks

2 analog input, 1 transducer, 1 physical

Integral display

LCD, 15 lines x 56 column dot matrix providing 2 lines indication as

– top: 5-digit (numeric) plus sign or 7-digit alphanumeric

– bottom: 7-digit alphanumeric

and additional 50-segment bargraph for indication of output in percentage of the analog input function block assigned to the primary variable.

User-definable matrix display mode:

– process variable in pressure units or

– primary variable in engineering units (output of transducer block) or

– output as percentage or engineering units of analog input function blocks

Display also indicates diagnostic messages and provides configuration facilities.

Secondary variable, static pressure and sensor temperature can be read.

Transmitter failure mode

On gross transmitter failure condition, detected by self-diagnostics, the output signal can be driven to defined conditions, selectable by the user as safe, last valid or calculated value. If electronic failure or short circuit occur the transmitter consumption is electronically limited at a defined value (20mA approx), for safety of the network.

FOUNDATION Fieldbus output

Device type

LINK MASTER DEVICE

Link Active Scheduler (LAS) capability implemented.

Power supply

The transmitter operates from 9 to 32VDC, polarity independent.

For EEx ia approval power supply must not exceed 24VDC (entity certification) or 17.5VDC (FISCO certification), according to FF-816.

Current consumption

operating (quiescent): 10.5mA

fault current limiting: 20mA max.

Output signal

Physical layer in compliance to IEC 1158-2/EN 61158-2 with transmission to Manchester II modulation, at 31.25kbit/sec.

Function blocks/execution period

2 enhanced Analog Input blocks/25ms max (each)

1 enhanced PID block/40ms max.

1 standard ARithmetic block/25ms

1 standard Input Selector block/25ms

1 standard Control Selector block/25ms

1 standard Signal Characterization block/25ms

1 standard Integrator/Totalizer block/25ms

Additional blocks

1 enhanced Resource block

1 custom Pressure with calibration transducer block

1 custom Advanced Diagnostics transducer block including Plugged Input Line Detection

1 custom Local Display transducer block

Number of link objects

35

Number of VCRs

35

Output interface

FOUNDATION fieldbus digital communication protocol to standard H1, compliant to specification V. 1.6; FF registration in progress.

Integral display

LCD, 15 lines x 56 column dot matrix providing 2 lines indication as

– top: 5-digit (numeric) plus sign or 7-digit alphanumeric

– bottom: 7-digit alphanumeric

and additional 50-segment bargraph for percentage indication of the analog input function block output, assigned to the primary variable.

User-definable matrix display mode:

– process variable in pressure units or

– primary variable in engineering units (output of transducer block) or

– output as percentage or engineering units of one or more selected function blocks

Display also indicates diagnostic messages. Secondary variable, static pressure and sensor temperature can be read.

Transmitter failure mode

The output signal is "frozen" to the last valid value on gross transmitter failure condition, detected by self-diagnostics which also indicate a BAD conditions. If electronic failure or short circuit occur the transmitter consumption is electronically limited at a defined value (20mA approx), for safety of the network.

Performance specifications

Stated at reference condition to IEC 60770 ambient temperature of 20°C (68°F), relative humidity of 65%, atmospheric pressure of 1013hPa (1013mbar), mounting position with vertical diaphragm and zero based range for transmitter with isolating diaphragms in AISI 316L ss or Hastelloy and silicone oil fill and digital trim values equal to span end points, in linear mode.

Unless otherwise specified, errors are quoted as % of span.

Some performance data are affected by the actual turndown (TD) as ratio between Upper Range Limit (URL) and calibrated span.

IT IS RECOMMENDED TO SELECT THE TRANSMITTER SENSOR CODE PROVIDING THE TURNDOWN VALUE AS LOWEST AS POSSIBLE TO OPTIMIZE PERFORMANCE CHARACTERISTICS.

Accuracy rating

% of calibrated span, including combined effects of terminal based linearity, hysteresis and repeatability.

For fieldbus versions SPAN refer to analog input function block outscale range

Using remote seal sizes <DN 80/3in

- ±0.10% for TD from 1:1 to 10:1
(±0.10% for sensor codes B and E for TD from 1:1 to 5:1)

- ±0.01% x $\frac{URL}{Span}$ for TD from 10:1 to 20:1

±0.02% x $\frac{URL}{Span}$ for sensor codes B and E for TD from 5:1 to 10:1

Using remote seal sizes ≥ DN 80/3in

- ±0.075% for TD from 1:1 to 10:1
(±0.10% for sensor codes B and E for TD from 1:1 to 5:1)

- ±0.0075% x $\frac{URL}{Span}$ for TD from 10:1 to 20:1

(±0.02% x $\frac{URL}{Span}$ for sensor codes B and E for TD from 5:1 to 10:1)

Multiply the values by 1.5 for sensor/seal combination marked (●) and for transmitter for absolute measurement.

Operating influences

Temperature effects

per 20K (36°F) ambient temperature change on transmitter sensor between the limits of -20°C to +65°C (-4 to +150°F):

Model	Sensor Code	for TD up to	
264DR	E to S	10:1	±(0.04% URL +0.065% span)
264PR	B	5:1	±(0.06% URL +0.10% span)
264VR	E to S	10:1	±(0.08% URL +0.13% span)
264HR/NR	G to S	10:1	±(0.04% URL +0.065% span)
264HR	V	10:1	±(0.06% URL +0.10% span)

The total temperature error is the combination of the above transmitter effect with seal errors, as applicable due to application temperatures.

Refer to seal data sheet for additional effects of the remote seal.

Optional CoMeter and ProMeter ambient temperature

Total reading error per 20K (36°F) change between the ambient limits of -20 and +70°C (-4 and +158°F) :

±0.15% of max span (16mA).

Static pressure (zero errors can be calibrated out at line pressure)

for differential measurement per 2MPa, 20bar or 290psi.

Model 264DR with remote seal(s)

- zero error: ±0.25% of URL
- span error: ±0.25% of reading

Multiply by 1.5 the errors for sensor codes B and E and for sensor/seal combinations marked (●)

Supply voltage

Within voltage/load specified limits the total effect is less than 0.005% of URL per volt.

Load

Within load/voltage specified limits the total effect is negligible.

Electromagnetic field

Total effect : less than 0.10% of span from 20 to 1000MHz and for field strengths up to 30V/m when tested with shielded conduit and grounding, with or without meter.

Common mode interference

No effect from 100Vrms @ 50Hz, or 50VDC

Vibration effect

±0.10% of URL (according to IEC 61298-3)

Physical Specification

(Refer to ordering information sheets of transmitter and seal(s) for variant availability related to specific model or versions code)

Materials

Model 264DR only – Side without seal

Process isolating diaphragms (*)

AISI 316 L ss; Hastelloy C276™; Monel 400™; Tantalum;
Hastelloy C276™ on AISI 316 L ss gasket seat.
A remote seal can be selected with required diaphragm (refer below)

Process flanges, adapters, plugs and drain/vent valves (*)

AISI 316 L ss; Hastelloy C276™; Monel 400™.

Bolts and nuts

AISI 316 ss bolts Class A4–80 and nuts Class A4-70 per UNI 7323 (ISO 3506);
AISI 316 ss bolts and nuts Class A4–50 per UNI 7323 (ISO 3506), in compliance with NACE MR0175 Class II.

Gaskets (*)

Viton™; PTFE.

Models 264DR/PR/VR/HR/NR

Blind flange (reference and/or remote seal(s) side)

AISI 316 L ss

Seal side process diaphragm (remote seal) (*)

AISI 316 L ss; Hastelloy C276™; Hastelloy C2000™; Inconel 625; Tantalum; AISI 316 L ss or Hastelloy C276™ with anti-stick coating; AISI 316 L ss with anti-corrosion coating; AISI 316 L ss gold plated; Superduplex ss (UNS S32750 to ASTM SA479); Diaflex (AISI with anti-abrasion treatment).

Extension material

AISI 316 L ss (also for Diaflex and gold plated diaphragms); Hastelloy C276™;
AISI 316 L ss or Hastelloy C276™ with coating same as diaphragm

Seal side fill fluid (remote seal)

Silicone oil-DC200™; Silicone oil-AN140™; Inert-Halocarbon™4.2; Inert-Galden™; Silicone Polymer-Syltherm XTL™; Vegetable oil-Neobee M-20™; Glycerin Water; Mineral oil-MARCOL 82™.

Sensor fill fluid

Silicone oil (DC200™); inert fill (Halocarbon™4.2 or Galden™).

Sensor housing

AISI 316 L ss.

Electronic housing and covers

Barrel version
– Aluminium alloy with baked epoxy finish;
– Copper-free content aluminium alloy with baked epoxy finish;
– AISI 316 L ss.
DIN version
– Aluminium alloy with baked epoxy finish.

Covers O-ring

Buna N.

Local zero and span adjustments:

Glass filled polycarbonate plastic (removable).

Tagging

AISI 316ss data plate attached to the electronics housing.

Calibration

Standard: at maximum span, zero based range, ambient temperature and pressure;

Optional: at specified range and ambient conditions;.

Optional extras

Output indicator

plug-in rotatable type, LCD or analog.

Supplemental customer tag

AISI 316 ss tag screwed/fastened to the transmitter for customer's tag data up to a maximum of 20 characters and spaces on one line for tag number and tag name, and up to a maximum of 3 spaced strings of 10 characters each for calibration details (lower and upper values plus unit). Special typing evaluated on request for charges.

Surge protection (only as external unit for PROFIBUS PA and FF)

Test Certificates (test, design, calibration, material traceability)

Tag and manual language

Communication connectors

Process connections

on conventional flanges : 1/4 – 18 NPT on process axis

on adapters : 1/2 – 14 NPT on process axis

fixing threads: 7/16 – 20 UNF at 41.3mm centre distance

Refer to seal data sheet for process connection variants through remote seal.

Electrical connections

Two 1/2 – 14 NPT or M20x1.5 or PG 13.5 or 1/2 GK threaded conduit entries, direct on housing.

Special communication connector (on request)

– HART : straight or angle Harting Han connector and one plug.

– FOUNDATION Fieldbus, PROFIBUS PA: M12x1 or 7/8.

Terminal block

HART version: three terminals for signal/external meter wiring up to 2.5mm² (14AWG) and three connection points for test and communication purposes.

Fieldbus versions: two terminals for signal wiring (bus connection) up to 2.5mm² (14AWG)

Grounding

Internal and external 6mm² (10AWG) ground termination points are provided.

Mounting position

Transmitter can be mounted in any position.

Electronics housing may be rotated to any position. A positive stop prevents over travel.

Mass (without options and seals)

– models 264DR/PR/VR : 3kg approx (7lb)

– models 264HR/NR: 1.7kg approx (4lb)

Add 1.5kg (3.4lb) for AISI housing.

Add 650g (1.5lb) for packing.

Packing

Carton

(*) Wetted parts of the transmitter.

(**) U-bolt material: AISI 400 ss; screws material: high-strength alloy steel or AISI 316 ss.

Configuration

Transmitter with HART communication and 4 to 20 mA

Standard configuration

Transmitters are factory calibrated to customer's specified range. Calibrated range and tag number are stamped on the tag plate. If a calibration range and tag data are not specified, the transmitter will be supplied with the plate left blank and configured as follows:

Engineering Unit	kPa
4 mA	Zero
20 mA	Upper Range Limit (URL)
Output	Linear
Damping	1 sec.
Transmitter failure mode	Upscale
Software tag (8 characters max)	Blank
Optional LCD indicator/display	0 to 100.0% linear

Any or all the above configurable parameters, including Lower range-value and Upper range-value which must be the same unit of measure, can be easily changed using the HART hand-held communicator or by a PC running the configuration software SMART VISION with DTM for 2600T. The transmitter database is customized with specified flange type and material, O-ring and drain/vent materials and meter code option.

Custom configuration (option)

The following data may be specified in addition to the standard configuration parameters:

Descriptor	16 alphanumeric characters
Message	32 alphanumeric characters
Date	Day, month, year

Transmitter with PROFIBUS PA communication

Transmitters are factory calibrated to customer's specified range. Calibrated range and tag number are stamped on the tag plate. If a calibration range and tag data are not specified, the transmitter will be supplied with the plate left blank and configured as follows:

Measure Profile	Pressure
Engineering Unit	kPa
Output scale 0%	Lower Range Limit (LRL)
Output scale 100%	Upper Range Limit (URL)
Output	Linear
Hi-Hi Limit	Upper Range Limit (URL)
Hi Limit	Upper Range Limit (URL)
Low Limit	Lower Range Limit (LRL)
Low-Low Limit	Lower Range Limit (LRL)
Limits hysteresis	0.5% of output scale
PV filter	0 sec.
Address (settable by local key)	126
Tag	32 alphanumeric characters

Any or all the above configurable parameters, including Lower range-value and Upper range-value which must be the same unit of measure, can be easily changed by a PC running the configuration software SMART VISION with DTM for 2600T.

The transmitter database is customized with specified flange type and material, O-ring and drain/vent materials and meter code option.

Custom configuration (option)

The following data may be specified in addition to the standard configuration parameters:

Descriptor	32 alphanumeric characters
Message	32 alphanumeric characters
Date	Day, month, year

Transmitter with FOUNDATION Fieldbus communication

Transmitters are factory calibrated to customer's specified range. Calibrated range and tag number are stamped on the tag plate. If a calibration range and tag data are not specified, the transmitter will be supplied with the plate left blank and the analog input function block FB1 is configured as follows:

Measure Profile	Pressure
Engineering Unit	kPa
Output scale 0%	Lower Range Limit (LRL)
Output scale 100%	Upper Range Limit (URL)
Output	Linear
Hi-Hi Limit	Upper Range Limit (URL)
Hi Limit :	Upper Range Limit (URL)
Low Limit	Lower Range Limit (LRL)
Low-Low Limit	Lower Range Limit (LRL)
Limits hysteresis	0.5% of output scale
PV filter time	0 sec.
Tag	32 alphanumeric characters

The analog input function block FB2 is configured for the sensor temperature measured in °C. Any or all the above configurable parameters, including the range values, can be changed using any host compliant to FOUNDATION fieldbus. The transmitter database is customized with specified flange type and material, O-ring and drain/vent materials and meter code option.

For any protocol available engineering units of pressure measure are :

Pa, kPa, MPa
 inH₂O@4°C, mmH₂O@4°C, psi
 inH₂O@20°C, ftH₂O@20°C, mmH₂O@20°C
 inHg, mmHg, Torr
 g/cm², kg/cm², atm
 mbar, bar

MOUNTING DIMENSIONS (not for construction unless certified) - dimensions in mm (in)

264DR/PR/VR transmitter on bracket for vertical or horizontal 60mm (2in) pipe mounting (barrel housing)

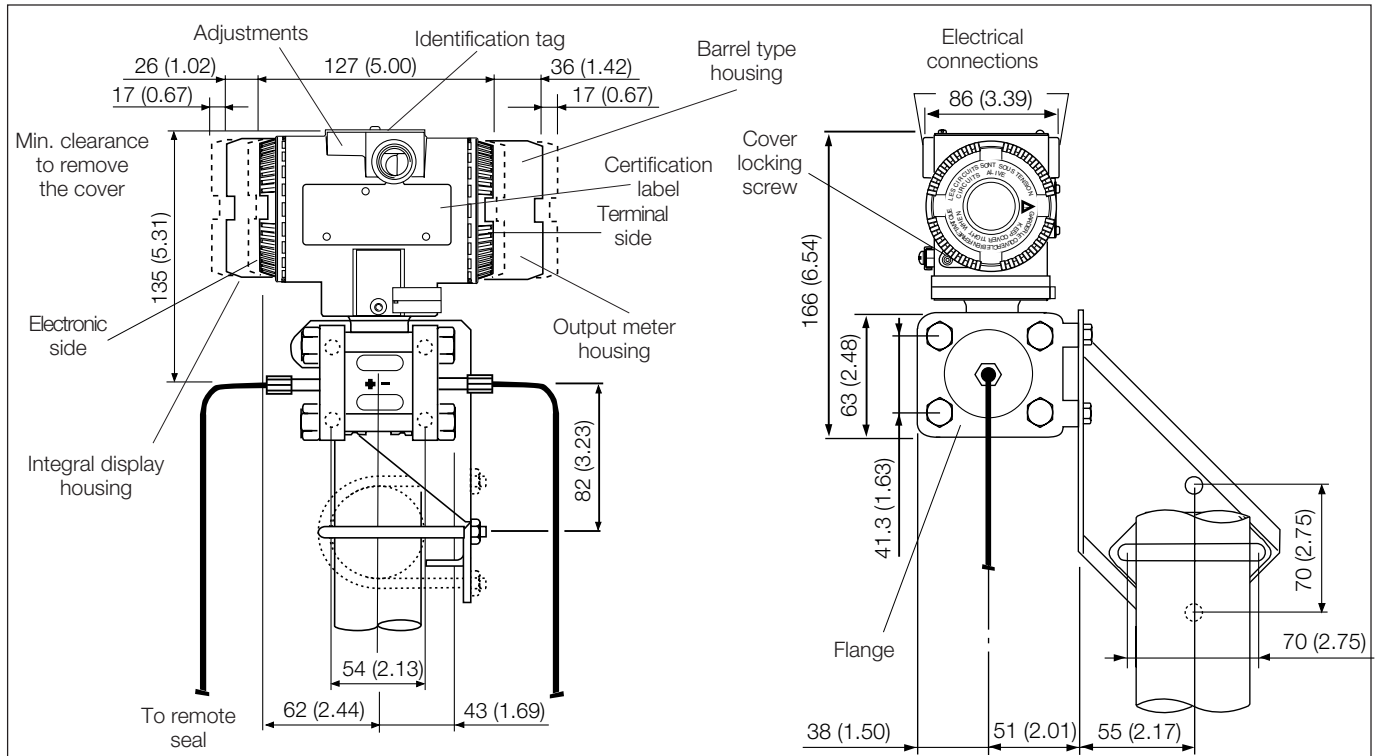

Consider one capillary only to remote seal for 264PR/VR

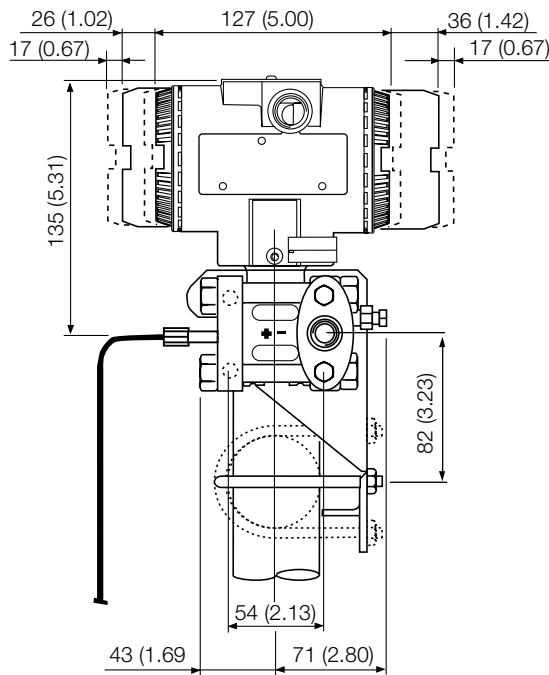

Note : For 264DR side with 1/4 - 18 NPT thread director with 1/2 - 14 NPT through adapter, threaded process connection, gasket groove and gaskets are in accordance with DIN 19213.
Bolting threads for fixing adapter or other devices (i.e. manifold etc.) on process flange is 7/16 - 20 UNF.

264DR/PR/VR transmitter on bracket for vertical or horizontal 60mm (2in) pipe mounting (DIN housing)

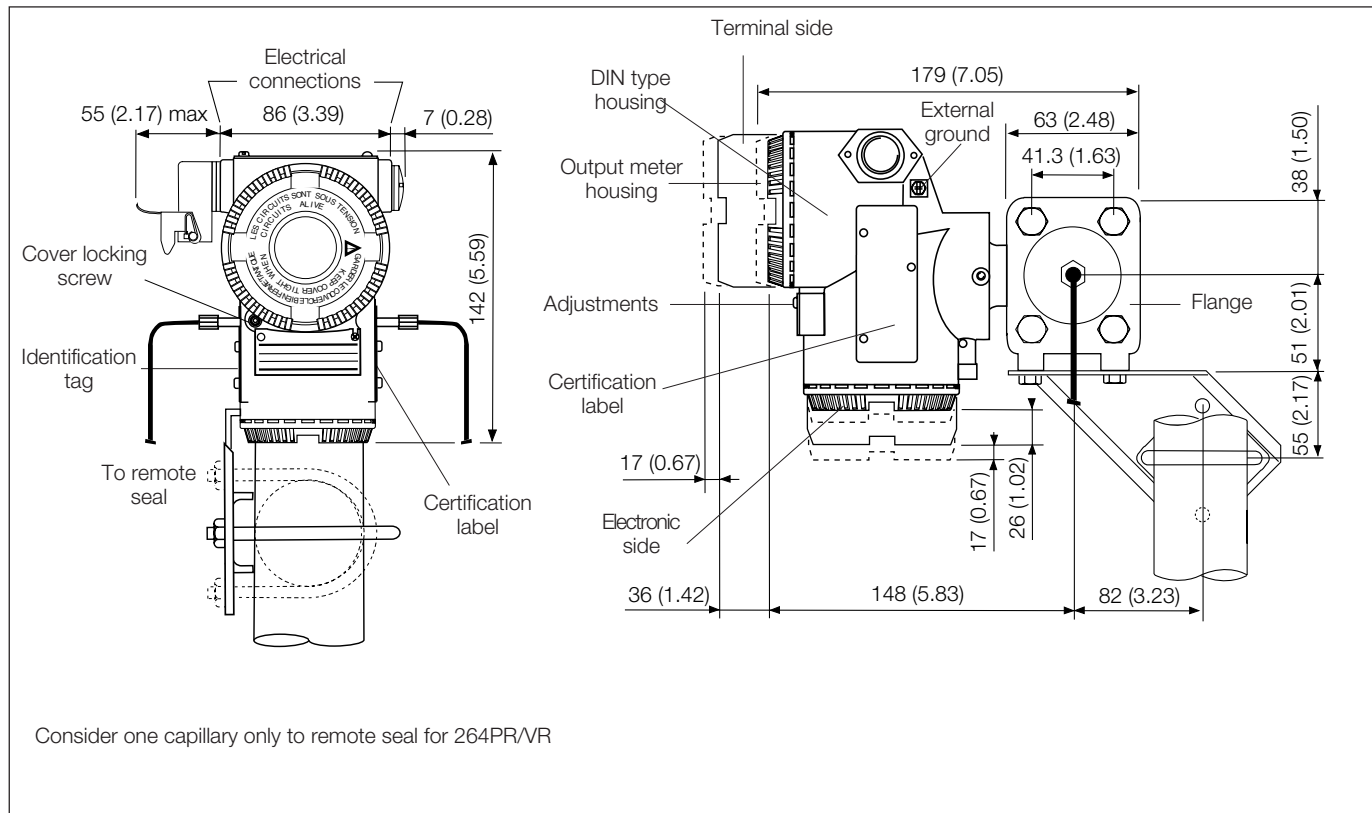

264DR/PR/VR transmitter on bracket for vertical or horizontal 60mm (2in) pipe mounting

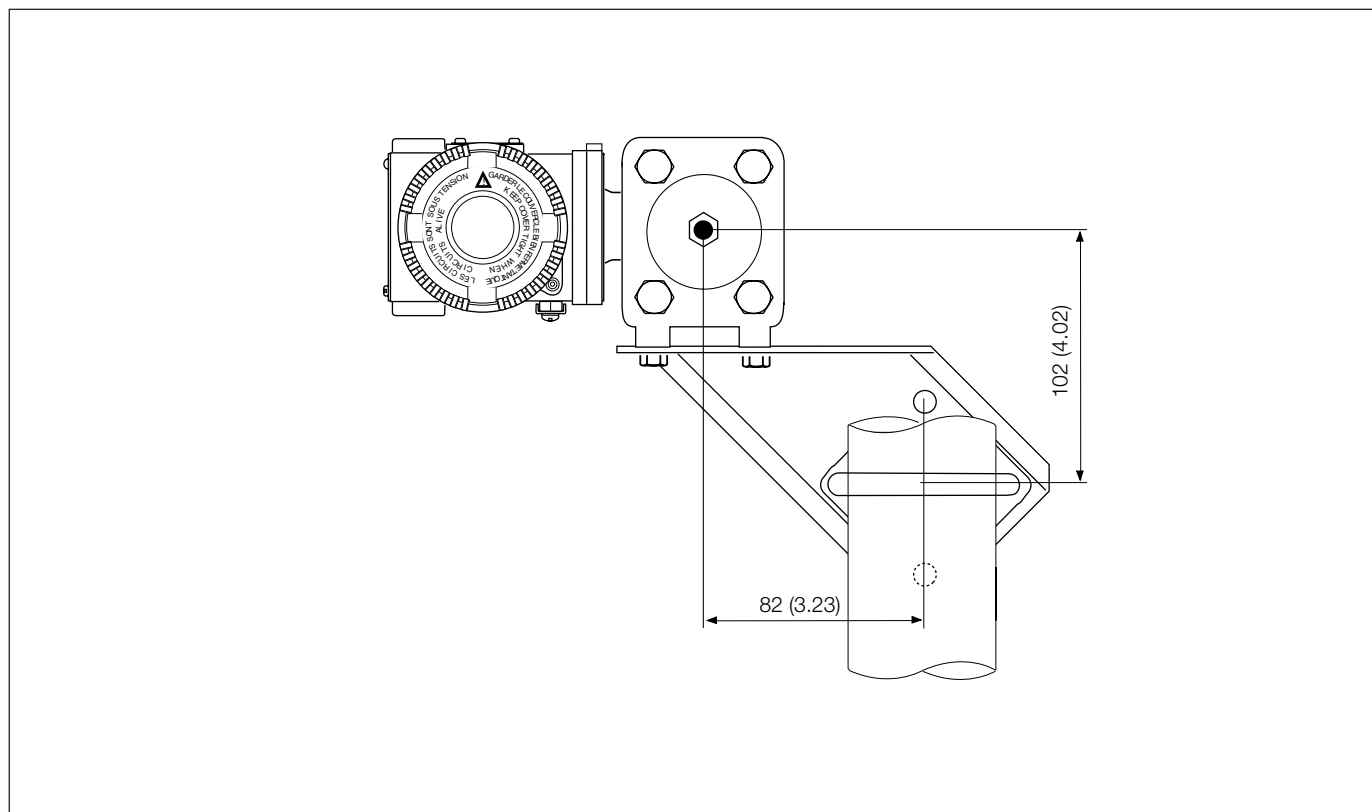

264DR/PR/VR transmitter on bracket for wall mounting (by up to four M8 screws; NOT SUPPLIED)

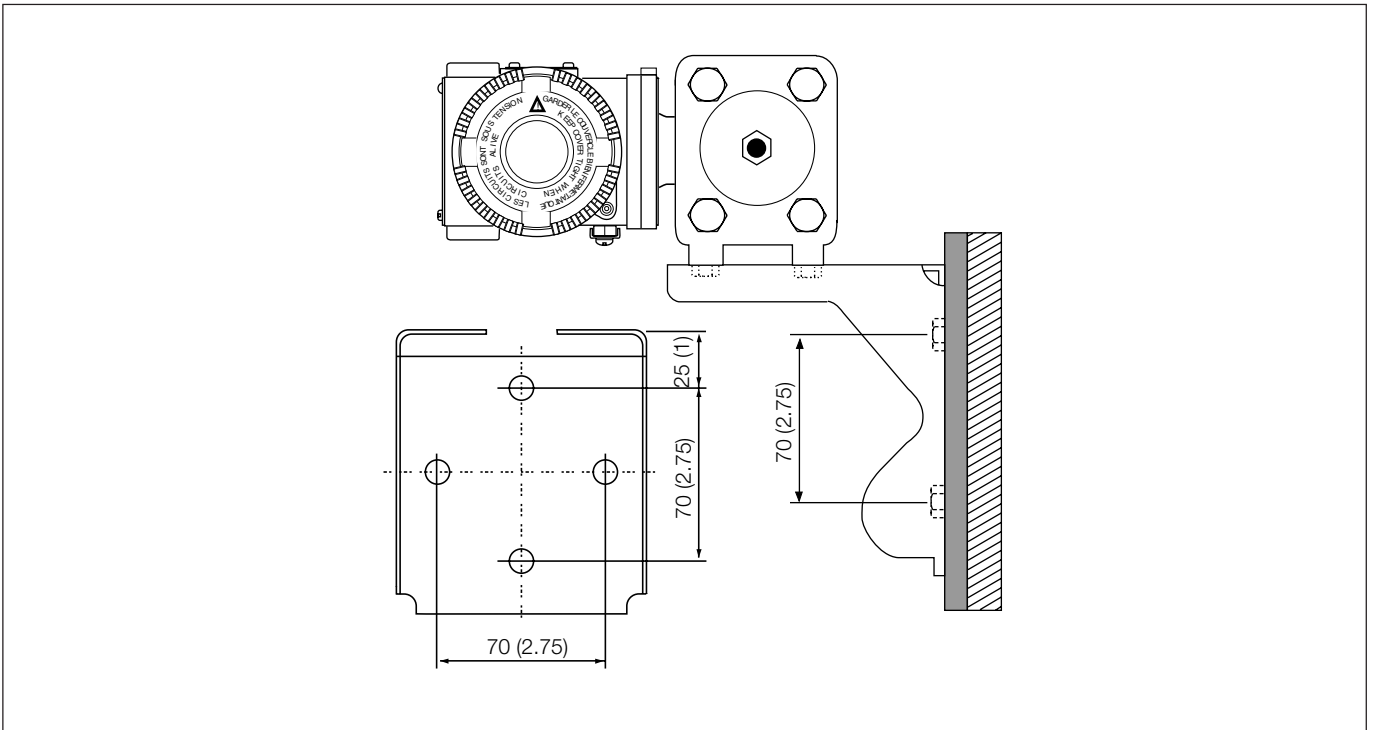

264DR/PR/VR transmitter on flat type (for box) bracket for vertical or horizontal 60mm (2in) pipe mounting

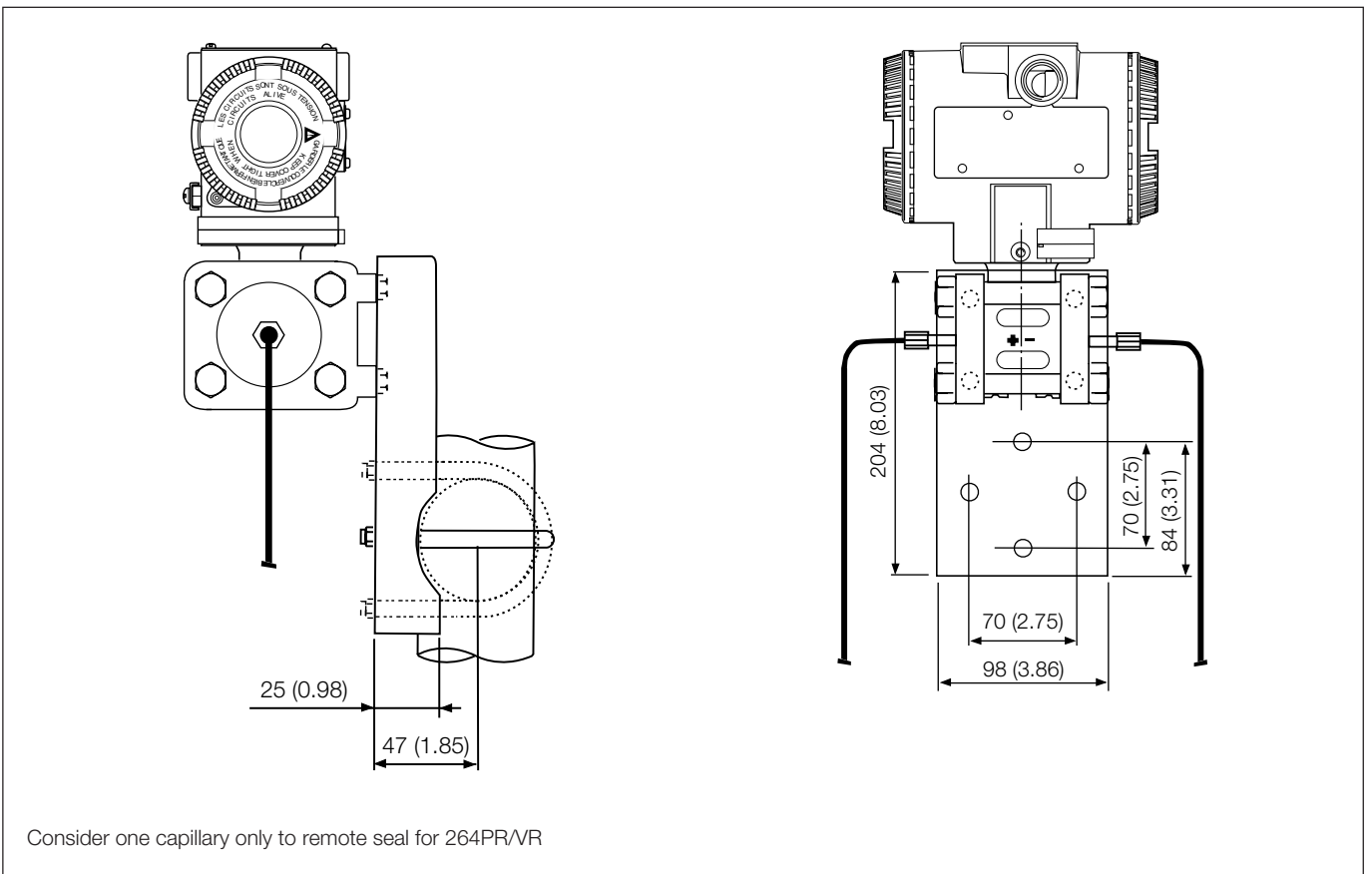

Electrical connections

HART Version

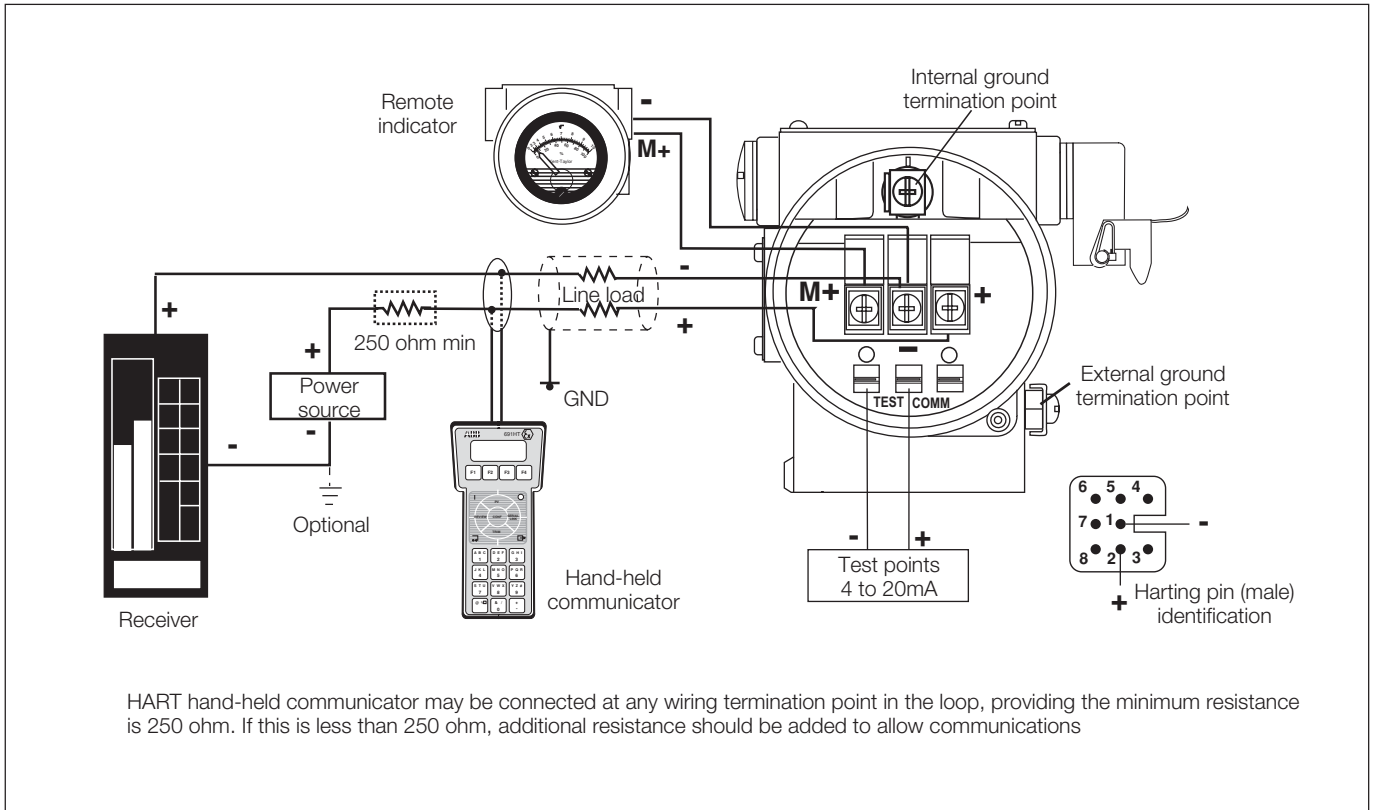

FIELDBUS Versions

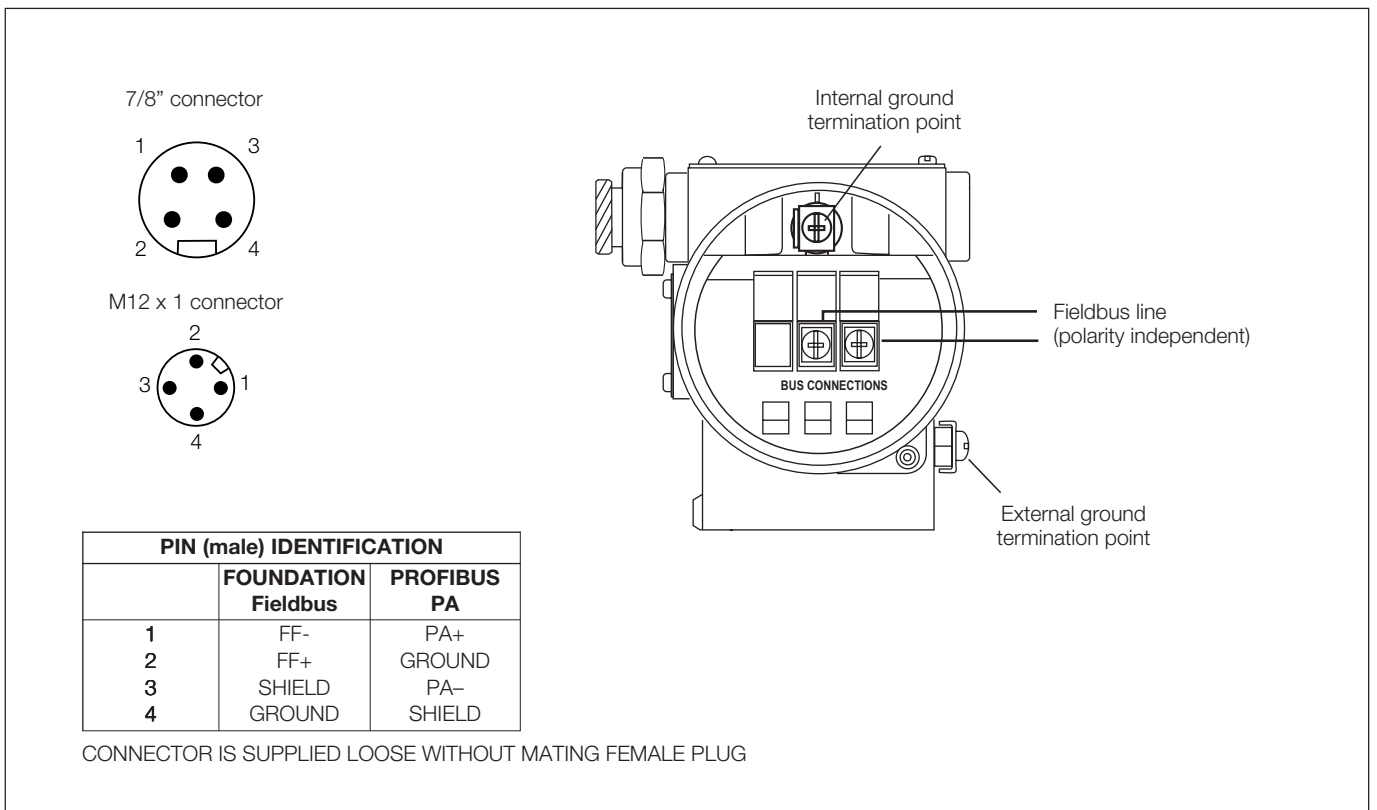

2600T Pressure Transmitters

Model 264DR, 264PR, 264HR, 264VR, 264NR

SS/264XR_7

BASIC ORDERING INFORMATION model 264DR Differential Pressure Transmitter with remote seal(s)

Select one character or set of characters from each category and specify complete catalog number.

Refer to additional ordering information code and specify one or more codes for each transmitter if additional options are required.

Quote separately one or two seals as required.

BASE MODEL – 1 st to 5 th characters			2	6	4	D	R	X	S	X	X	X	Cont'd
Differential Pressure Transmitter with remote seal(s) – BASE ACCURACY 0.075%													
SENSOR - Span limits – 6th character													
0.2 and 4kPa	2 and 40mbar	0.8 and 16inH ₂ O						B					
0.54 and 16kPa	5.4 and 160mbar	2.16 and 64inH ₂ O						E					
0.67 and 40kPa	6.7 and 400mbar	2.67 and 160inH ₂ O						F					
1.1 and 65kPa	11 and 650mbar	4.35 and 260inH ₂ O						G					
2.67 and 160kPa	26.7 and 1600mbar	10.7 and 642inH ₂ O						H					
10 and 600kPa	0.1 and 6bar	1.45 and 87psi						M					
40 and 2400kPa	0.4 and 24bar	5.8 and 348psi						P					
134 and 8000kPa	1.34 and 80bar	19.4 and 1160psi						Q					
267 and 16000kPa	2.67 and 160bar	38.7 and 2320psi						S					
Use code – 7th character									S				
Diaphragm material / Fill fluid (wetted parts) – 8th character													
AISI 316 L ss	Silicone oil	(one seal to be quoted separately)	(Note 3)						S				
Hastelloy C276™ (on AISI seat)	Silicone oil	(one seal to be quoted separately)	(Note 3)					NACE	H				
Hastelloy C276™	Silicone oil	(one seal to be quoted separately)	(Note 3)					NACE	K				
Monel 400™	Silicone oil	(one seal to be quoted separately)	(Note 3)					NACE	M				
Tantalum	Silicone oil	(one seal to be quoted separately)	(Note 3)					NACE	T				
AISI 316 L ss	Inert fluid-Galden	(one seal to be quoted separately)	(Notes 1, 3)						A				
Hastelloy C276™ (on AISI seat)	Inert fluid-Galden	(one seal to be quoted separately)	(Notes 1, 3)					NACE	B				
Hastelloy C276™	Inert fluid-Galden	(one seal to be quoted separately)	(Notes 1, 3)					NACE	F				
Monel 400™	Inert fluid-Galden	(one seal to be quoted separately)	(Notes 1, 3)					NACE	C				
Tantalum	Inert fluid-Galden	(one seal to be quoted separately)	(Notes 1, 3)					NACE	D				
AISI 316 L ss	Inert fluid-Halocarbon	(one seal to be quoted separately)	(Notes 1, 3)						L				
Hastelloy C276™ (on AISI seat)	Inert fluid-Halocarbon	(one seal to be quoted separately)	(Notes 1, 3)					NACE	Q				
Hastelloy C276™	Inert fluid-Halocarbon	(one seal to be quoted separately)	(Notes 1, 3)					NACE	P				
Monel 400™	Inert fluid-Halocarbon	(one seal to be quoted separately)	(Notes 1, 3)					NACE	4				
Tantalum	Inert fluid-Halocarbon	(one seal to be quoted separately)	(Notes 1, 3)					NACE	5				
AISI 316 L ss	Silicone oil	(two seals to be quoted separately)	(Note 2)						R				
AISI 316 L ss	Inert fluid-Galden	(two seals to be quoted separately)	(Notes 1, 3)						2				
AISI 316 L ss	Inert fluid-Halocarbon	(two seals to be quoted separately)	(Notes 1, 3)						W				
Process flanges/adapters material and connection (wetted parts) – 9th character													
AISI 316 L ss for two seals construction			(Note 4)					NACE				R	
AISI 316 L ss (Horizontal connection)			(Note 5)					NACE				A	
AISI 316 L ss (Horizontal connection)	1/4 – 18 NPT-f direct (7/16 – 20 UNF U.S. drilling)		(Note 5)					NACE				B	
AISI 316 L ss (Horizontal connection)	1/2 – 14 NPT-f through adapter (7/16 – 20 UNF U.S. drilling)		(Note 5)					NACE				A	
Hastelloy C276™ (Horizontal connection)	1/4 – 18 NPT-f direct (7/16 – 20 UNF U.S. drilling)		(Notes 5, 6)					NACE				D	
Hastelloy C276™ (Horizontal connection)	1/2 – 14 NPT-f through adapter (7/16 – 20 UNF U.S. drilling)		(Notes 5, 6)					NACE				E	
Monel 400™ (Horizontal connection)	1/4 – 18 NPT-f direct (7/16 – 20 UNF U.S. drilling)		(Notes 5, 6)					NACE				G	
Monel 400™ (Horizontal connection)	1/2 – 14 NPT-f through adapter (7/16 – 20 UNF U.S. drilling)		(Notes 5, 6)					NACE				H	
Bolts/Gasket (wetted parts) – 10th character													
AISI 316 ss (NACE) without gaskets for two seals construction			(Note 4)					NACE					R
AISI 316 ss without gaskets for two seals construction			(Note 4)										S
AISI 316 ss	Viton™		(Note 5)										1
AISI 316 ss	PTFE		(Notes 1, 5)										2
AISI 316 ss (NACE)	Viton™		(Note 5)					NACE					3
AISI 316 ss (NACE)	PTFE		(Notes 1, 5)					NACE					4

2600T Pressure Transmitters

Model 264DR, 264PR, 264HR, 264VR, 264NR

SS/264XR_7

BASIC ORDERING INFORMATION 264DR				X	X
Housing material and electrical connection – 11th character					
Aluminium alloy (Barrel version)	1/2 – 14 NPT				A
Aluminium alloy (Barrel version)	M20 x 1.5 (CM 20)				B
Aluminium alloy (Barrel version)	Pg 13.5				D
Aluminium alloy (Barrel version)	1/2 GK				C
Aluminium alloy (Barrel version)	Harting Han connector	(general purpose only)	(Note 7)		E
Aluminium alloy (Barrel version)	Fieldbus connector	(general purpose only)	(Note 7)		G
Aluminium alloy copper-free (Barrel version)	1/2 – 14 NPT				H
Aluminium alloy copper-free (Barrel version)	M20 x 1.5 (CM 20)				L
Aluminium alloy copper-free (Barrel version)	Pg 13.5				N
Aluminium alloy copper-free (Barrel version)	1/2 GK				M
Aluminium alloy copper-free (Barrel version)	Harting Han connector	(general purpose only)	(Note 7)		P
Aluminium alloy copper-free (Barrel version)	Fieldbus connector	(general purpose only)	(Note 7)		R
AISI 316 L ss (Barrel version)	1/2 – 14 NPT				S
AISI 316 L ss (Barrel version)	M20 x 1.5 (CM20)				T
AISI 316 L ss (Barrel version)	Pg 13.5				V
AISI 316 L ss (Barrel version)	1/2 GK				U
AISI 316 L ss (Barrel version)	Fieldbus connector	(general purpose only)	(Note 7)		Z
Aluminium alloy (DIN version)	M20 x 1.5 (CM 20)	(general purpose only)			J
Aluminium alloy (DIN version)	Pg 13.5	(general purpose only)			Y
Aluminium alloy (DIN version)	Harting Han connector	(general purpose only)	(Note 7)		K
Output/Additional options – 12th character					
HART digital communication and 4 to 20mA	No additional options		(Notes 8, 9)		H
HART digital communication and 4 to 20mA	Options requested (to be ordered by "Additional ordering code")		(Note 8)		1
PROFIBUS PA	No additional options		(Notes 8, 9)		P
PROFIBUS PA	Options requested (to be ordered by "Additional ordering code")		(Note 9)		2
FOUNDATION Fieldbus	No additional options		(Notes 8, 9)		F
FOUNDATION Fieldbus	Options requested (to be ordered by "Additional ordering code")		(Note 9)		3

2600T Pressure Transmitters

Model 264DR, 264PR, 264HR, 264VR, 264NR

SS/264XR_7

ADDITIONAL ORDERING INFORMATION for model 264DR

Add one or more 2-digit code(s) after the basic ordering information to select all required options

	XX	XX	XX	XX	XX	XX	XX	XX	XX	Cont'd
Drain/vent valve (material and position) (wetted parts)										
AISI 316 L ss on process axis (Note 10) NACE	V1									
AISI 316 L ss on flange side top (Note 10) NACE	V2									
AISI 316 L ss on flange side bottom (Note 10) NACE	V3									
Hastelloy C276™ on process axis (Note 11) NACE	V4									
Hastelloy C276™ on flange side top (Note 11) NACE	V5									
Hastelloy C276™ on flange side bottom (Note 11) NACE	V6									
Monel 400™ on process axis (Note 12) NACE	V7									
Monel 400™ on flange side top (Note 12) NACE	V8									
Monel 400™ on flange side bottom (Note 12) NACE	V9									
Electrical certification										
ATEX Group II Category 1 GD – Intrinsic Safety EEx ia	E1									
ATEX Group II Category 1/2 GD – Flameproof EEx d	E2									
ATEX Group II Category 3 GD – Type of protection "N" EEx nL design compliance (Note 13)	E3									
Canadian Standard Association (CSA) (only 1/2–14NPT, M20 and Pg 13.5 electrical connection)	E4									
Standards Australia SAA (Not Ex ia and Ex n for PROFIBUS PA and FOUNDATION Fieldbus)	E5									
Factory Mutual (FM) approval (only with 1/2–14NPT, M20 and Pg 13.5 electrical connection)	E6									
Combined ATEX - Intrinsic Safety and Flameproof	E7									
Combined ATEX, FM and CSA (only with 1/2–14NPT, M20 and Pg 13.5 electrical connection) (Note 13)	EN									
NEPSI (China) - Intrinsic Safety Ex ia	EY									
NEPSI (China) - Flameproof Ex d	EZ									
GOST (Russia) EEx ia	W1									
GOST (Russia) EEx d	W2									
GOST (Kazakhstan) EEx ia	W3									
GOST (Kazakhstan) EEx d	W4									
Inmetro (Brazil) EEx ia	W5									
Inmetro (Brazil) EEx d	W6									
Inmetro (Brazil) EEx nL	W7									
Metrologic (Russia)	WC									
Metrologic (Kazakhstan)	WD									
Output meter										
ProMeter, Standard calibration (Note 13)	D1									
ProMeter, Special calibration (Note 13)	D2									
Analog output indicator linear 0–100% scale (Note 13)	D3									
Analog output indicator square root 0–10 scale (Note 13)	D4									
Analog output indicator, special graduation (to be specified for linear scale) (Note 13)	D5									
Analog output indicator, special graduation (to be specified for square root scale) (Note 13)	D6									
Programmable signal meter and HART configurator (CoMeter) (Note 13)	D7									
Programmable signal meter and HART configurator (CoMeter – customer configuration) (Note 13)	D8									
Integral LCD										
Digital LCD integral display	L1									
Mounting bracket (shape and material)										
For pipe mounting (Not suitable for AISI housing) Carbon steel	B1									
For pipe mounting (Not suitable for AISI housing) AISI 316 L ss	B2									
For wall mounting (Not suitable for AISI housing) Carbon steel	B3									
For wall mounting (Not suitable for AISI housing) AISI 316 L ss	B4									
Flat type for box AISI 316 L ss	B5									
Surge										
Surge/Transient Protector (Internal for HART / 4-20mA)										
Surge/Transient Protector (External supplied loose for PROFIBUS PA and FOUNDATION Fieldbus only suitable with 1/2–14NPT and M20 electrical connection and with ATEX, FM and CSA certifications, no DUST)	S1									
Operating manual										
German	M1									
Italian	M2									
Spanish	M3									
French	M4									
Labels & tag language										
German	T1									
Italian	T2									
Spanish	T3									
French	T4									
Additional tag plate										
Laser printing of tag on stainless steel plate	I2									

2600T Pressure Transmitters

Model 264DR, 264PR, 264HR, 264VR, 264NR

SS/264XR_7

	XX	XX	XX	XX
Configuration				
Standard – Pressure = inH ₂ O/psi at 20° C; Temperature = deg. F	N2			
Standard – Pressure = inH ₂ O/psi at 4° C; Temperature = deg. F	N3			
Standard – Pressure = inH ₂ O/psi at 20° C; Temperature = deg.C	N4			
Standard – Pressure = inH ₂ O/psi at 4° C; Temperature = deg. C	N5			
Custom	N6			
Certificates				
Inspection certificate EN 10204–3.1 of calibration (9-point)			C1	
Certificate of compliance with the order EN 10204–2.1 of instrument design			C6	
Material traceability				
Certificate of compliance with the order EN 10204–2.1 of process wetted parts				H1
Inspection certificate EN 10204–3.1 of process wetted parts				H3
Connector				
Fieldbus 7/8 (Recommended for FOUNDATION Fieldbus) - (supplied loose without mating female plug)	(Notes 9, 14)			U1
Fieldbus M12x1 (Recommended for PROFIBUS PA) - (supplied loose without mating female plug)	(Notes 9, 14)			U2
Harting Han – straight entry	(Notes 8, 14)			U3
Harting Han – angle entry	(Notes 8, 14)			U4

Note 1: Suitable for oxygen service

Note 2: Not wetted – Hastelloy C276™ on AISI seat for sensor code B

Note 3: Not wetted – Not available with sensor code B

Note 4: Not available with diaphragm/fill code S, H, K, M, T, A, B, F, C, D, L, Q, P, 4, 5

Note 5: Not available with diaphragm/fill code R, 2, W.

Note 6: Not available with diaphragm material/fill fluid code S, H, A, B, L, Q

Note 7: Select type in additional ordering code

Note 8: Not available with Electronic Housing code Z, R, G

Note 9: Not available with Electronic Housing code P, E and K

Note 10: Not available with Process flanges/adapters code D, E, G, H, R

Note 11: Not available with Process flanges/adapters code A, B, G, H, R

Note 12: Not available with Process flanges/adapters code A, B, D, E, R

Note 13: Not available with PROFIBUS PA and FF output code 2 or 3

Note 14: Not available with Electronic housing code U, S, T, V, H, M, L, N, D, C, A, B, J, Y

Standard delivery items (can be differently specified by additional ordering code)

- Adapters supplied loose
- Plug on axis (no drain/vent valves)
- General purpose (no electrical certification)
- No meter/display, no mounting bracket, no surge protection
- English manual and labels
- Configuration with kPa and deg. C units
- No test, inspection or material traceability certificates

THE SELECTION OF SUITABLE WETTED PARTS AND FILLING FLUID FOR COMPATIBILITY WITH THE PROCESS MEDIA IS A CUSTOMER'S RESPONSIBILITY, IF NOT OTHERWISE NOTIFIED BEFORE MANUFACTURING.

2600T Pressure Transmitters

Model 264DR, 264PR, 264HR, 264VR, 264NR

SS/264XR_7

BASIC ORDERING INFORMATION model 264PR Gauge Pressure Transmitter with remote seal

Select one character or set of characters from each category and specify complete catalog number.

Refer to additional ordering information code and specify one or more codes for each transmitter if additional options are required.

BASE MODEL – 1 st to 5 th characters				2	6	4	P	R	X	S	X	X	X	X	X
Gauge Pressure Transmitter with remote seal – BASE ACCURACY 0.075%															
SENSOR - Span limits – 6th character															
0.54 and 16kPa	5.4 and 160mbar	2.16 and 64inH ₂ O							E						
0.67 and 40kPa	6.7 and 400mbar	2.67 and 160inH ₂ O							F						
1.1 and 65kPa	11 and 650mbar	4.35 and 260inH ₂ O							G						
2.67 and 160kPa	26.7 and 1600mbar	10.7 and 642inH ₂ O							H						
10 and 600kPa	0.1 and 6bar	1.45 and 87psi							M						
40 and 2400kPa	0.4 and 24bar	5.8 and 348psi							P						
134 and 8000kPa	1.34 and 80bar	19.4 and 1160psi							Q						
267 and 16000kPa	2.67 and 160bar	38.7 and 2320psi							S						
Use code – 7th character										S					
Diaphragm material / Fill fluid – 8th character															
AISI 316 L ss	Silicone oil		(one seal to be quoted separately)								R				
AISI 316 L ss	Inert fluid-Galden		(one seal to be quoted separately)	(Note 1)							2				
AISI 316 L ss	Inert fluid-Halocarbon		(one seal to be quoted separately)	(Note 1)							W				
Process flanges/adapters material – 9th character															
AISI 316 L ss for seal construction														R	
Bolts – 10th character															
AISI 316 ss (NACE) without gaskets for seal construction										NACE				R	
AISI 316 ss without gaskets for seal construction														S	
Housing material and electrical connection – 11th character															
Aluminium alloy (Barrel version)	1/2 – 14 NPT														A
Aluminium alloy (Barrel version)	M20 x 1.5 (CM 20)														B
Aluminium alloy (Barrel version)	Pg 13.5														D
Aluminium alloy (Barrel version)	1/2 GK														C
Aluminium alloy (Barrel version)	Harting Han connector		(general purpose only)							(Note 2)					E
Aluminium alloy (Barrel version)	Fieldbus connector		(general purpose only)							(Note 2)					G
Aluminium alloy copper-free (Barrel version)	1/2 – 14 NPT														H
Aluminium alloy copper-free (Barrel version)	M20 x 1.5 (CM 20)														L
Aluminium alloy copper-free (Barrel version)	Pg 13.5														N
Aluminium alloy copper-free (Barrel version)	1/2 GK														M
Aluminium alloy copper-free (Barrel version)	Harting Han connector		(general purpose only)							(Note 2)					P
Aluminium alloy copper-free (Barrel version)	Fieldbus connector		(general purpose only)							(Note 2)					R
AISI 316 L ss (Barrel version)	1/2 – 14 NPT														S
AISI 316 L ss (Barrel version)	M20 x 1.5 (CM20)														T
AISI 316 L ss (Barrel version)	Pg 13.5														V
AISI 316 L ss (Barrel version)	1/2 GK														U
AISI 316 L ss (Barrel version)	Fieldbus connector		(general purpose only)							(Note 2)					Z
Aluminium alloy (DIN version)	M20 x 1.5 (CM 20)		(general purpose only)												J
Aluminium alloy (DIN version)	Pg 13.5		(general purpose only)												Y
Aluminium alloy (DIN version)	Harting Han connector		(general purpose only)							(Note 2)					K
Output/Additional options – 12th character															
HART digital communication and 4 to 20mA	No additional options									(Notes 3, 4)					H
HART digital communication and 4 to 20mA	Options requested (to be ordered by "Additional ordering code")									(Note 3)					1
PROFIBUS PA	No additional options									(Notes 3, 4)					P
PROFIBUS PA	Options requested (to be ordered by "Additional ordering code")									(Note 4)					2
FOUNDATION Fieldbus	No additional options									(Notes 3, 4)					F
FOUNDATION Fieldbus	Options requested (to be ordered by "Additional ordering code")									(Note 4)					3

ADDITIONAL ORDERING INFORMATION for model 264PR

Add one or more 2-digit code(s) after the basic ordering information to select all required options

	XX	XX	XX	XX	XX	XX	XX	XX	XX	XX	XX	XX
Electrical certification												
ATEX Group II Category 1 GD – Intrinsic Safety EEx ia	E1											
ATEX Group II Category 1/2 GD – Flameproof EEx d	E2											
ATEX Group II Category 3 GD – Type of protection "N" EEx nL design compliance (Note 5)	E3											
Canadian Standard Association (CSA) (only 1/2–14NPT, M20 and Pg 13.5 electrical connection)	E4											
Standards Australia SAA (Not Ex ia and Ex n for PROFIBUS PA and FOUNDATION Fieldbus)	E5											
Factory Mutual (FM) approval (only with 1/2–14NPT, M20 and Pg 13.5 electrical connection)	E6											
Combined ATEX - Intrinsic Safety and Flameproof	E7											
Combined ATEX, FM and CSA (only with 1/2–14NPT, M20 and Pg 13.5 electrical connection) (Note 5)	EN											
NEPSI (China) - Intrinsic Safety Ex ia	EY											
NEPSI (China) - Flameproof Ex d	EZ											
GOST (Russia) EEx ia	W1											
GOST (Russia) EEx d	W2											
GOST (Kazakhstan) EEx ia	W3											
GOST (Kazakhstan) EEx d	W4											
Inmetro (Brazil) EEx ia	W5											
Inmetro (Brazil) EEx d	W6											
Inmetro (Brazil) EEx nL	W7											
Metrologic (Russia)	WC											
Metrologic (Kazakhstan)	WD											
Output meter												
ProMeter, Standard calibration (Note 5)	D1											
ProMeter, Special calibration (Note 5)	D2											
Analog output indicator linear 0–100% scale (Note 5)	D3											
Analog output indicator, special graduation (to be specified for linear scale) (Note 5)	D5											
Programmable signal meter and HART configurator (CoMeter) (Note 5)	D7											
Programmable signal meter and HART configurator (CoMeter – customer configuration) (Note 5)	D8											
Integral LCD												
Digital LCD integral display											L1	
Mounting bracket (shape and material)												
For pipe mounting (Not suitable for AISI housing) Carbon steel	B1											
For pipe mounting (Not suitable for AISI housing) AISI 316 L ss	B2											
For wall mounting (Not suitable for AISI housing) Carbon steel	B3											
For wall mounting (Not suitable for AISI housing) AISI 316 L ss	B4											
Flat type for box AISI 316 L ss	B5											
Surge												
Surge/Transient Protector (Internal for HART / 4-20mA)												
Surge/Transient Protector (External supplied loose for PROFIBUS PA and FOUNDATION Fieldbus only suitable with 1/2–14NPT and M20 electrical connection and with ATEX, FM and CSA certifications, no DUST)											S1	
Operating manual												
German											M1	
Italian											M2	
Spanish											M3	
French											M4	
Labels & tag language												
German											T1	
Italian											T2	
Spanish											T3	
French											T4	
Additional tag plate												
Laser printing of tag on stainless steel plate											I2	
Configuration												
Standard – Pressure = inH ₂ O/psi at 20° C; Temperature = deg. F											N2	
Standard – Pressure = inH ₂ O/psi at 4° C; Temperature = deg. F											N3	
Standard – Pressure = inH ₂ O/psi at 20° C; Temperature = deg. C											N4	
Standard – Pressure = inH ₂ O/psi at 4° C; Temperature = deg. C											N5	
Custom											N6	
Certificates												
Inspection certificate EN 10204–3.1 of calibration (9-point)											C1	
Certificate of compliance with the order EN 10204–2.1 of instrument design											C6	
Material traceability												
Certificate of compliance with the order EN 10204–2.1 of process wetted parts											H1	
Inspection certificate EN 10204–3.1 of process wetted parts											H3	
Connector												
Fieldbus 7/8 (Recommended for FOUNDATION Fieldbus) - (supplied loose without mating female plug)										(Notes 4, 6)	U1	
Fieldbus M12x1 (Recommended for PROFIBUS PA) - (supplied loose without mating female plug)										(Notes 4, 6)	U2	
Harting Han – straight entry										(Notes 3, 6)	U3	
Harting Han – angle entry										(Notes 3, 6)	U4	

2600T Pressure Transmitters

Model 264DR, 264PR, 264HR, 264VR, 264NR

SS/264XR_7

- Note 1: Suitable for oxygen service
- Note 2: Select type in additional ordering code
- Note 3: Not available with Electronic Housing code Z, R, G
- Note 4: Not available with Electronic Housing code P, E and K
- Note 5: Not available with PROFIBUS PA and FF output code 2 or 3
- Note 6: Not available with Electronic housing code U, S, T, V, H, M, L, N, D, C, A, B, J, Y

Standard delivery items (can be differently specified by additional ordering code)

- General purpose (no electrical certification)
- No meter/display, no mounting bracket, no surge protection
- English manual and labels
- Configuration with kPa and deg. C units
- No test, inspection or material traceability certificates

THE SELECTION OF SUITABLE WETTED PARTS AND FILLING FLUID FOR COMPATIBILITY WITH THE PROCESS MEDIA IS A CUSTOMER'S RESPONSIBILITY, IF NOT OTHERWISE NOTIFIED BEFORE MANUFACTURING.

2600T Pressure Transmitters

Model 264DR, 264PR, 264HR, 264VR, 264NR

SS/264XR_7

BASIC ORDERING INFORMATION model 264HR Gauge Pressure Transmitter with remote seal

Select one character or set of characters from each category and specify complete catalog number.
Refer to additional ordering information code and specify one or more codes for each transmitter if additional options are required.

BASE MODEL – 1 st to 5 th characters			2	6	4	H	R	X	X	X	X	X
Gauge Pressure Transmitter with remote seal – BASE ACCURACY 0.075%												
SENSOR - Span limits – 6 th character												
1.1 and 65kPa	11 and 650mbar	4.35 and 260inH ₂ O						G				
2.67 and 160kPa	26.7 and 1600mbar	10.7 and 642inH ₂ O						H				
10 and 600kPa	0.1 and 6bar	1.45 and 87psi						M				
40 and 2400kPa	0.4 and 24bar	5.8 and 348psi						P				
134 and 8000kPa	1.34 and 80bar	19.4 and 1160psi						Q				
267 and 16000kPa	2.67 and 160bar	38.7 and 2320psi						S				
2000 and 60000kPa	20 and 600bar	290 and 8700psi						V				
Diaphragm material / Fill fluid – 7 th character												
AISI 316 L ss (Hastelloy C276 for sensor V)		Silicone oil							R			
AISI 316 L ss		Inert fluid-Galden				(Note 1)			2			
AISI 316 L ss		Inert fluid-Halocarbon				(Note 1)			W			
Process connection – 8 th character												
Remote seal (except button type)		(one seal to be quoted separately)								R		
Button type remote seal		(one button seal to be quoted separately)				(Note 2)				G		
Housing material and electrical connection – 9 th character												
Aluminium alloy (Barrel version)		1/2 – 14 NPT										A
Aluminium alloy (Barrel version)		M20 x 1.5 (CM 20)										B
Aluminium alloy (Barrel version)		Pg 13.5										D
Aluminium alloy (Barrel version)		1/2 GK										C
Aluminium alloy (Barrel version)		Harting Han connector				(general purpose only)	(Note 3)					E
Aluminium alloy (Barrel version)		Fieldbus connector				(general purpose only)	(Note 3)					G
Aluminium alloy copper-free (Barrel version)		1/2 – 14 NPT										H
Aluminium alloy copper-free (Barrel version)		M20 x 1.5 (CM 20)										L
Aluminium alloy copper-free (Barrel version)		Pg 13.5										N
Aluminium alloy copper-free (Barrel version)		1/2 GK										M
Aluminium alloy copper-free (Barrel version)		Harting Han connector				(general purpose only)	(Note 3)					P
Aluminium alloy copper-free (Barrel version)		Fieldbus connector				(general purpose only)	(Note 3)					R
AISI 316 L ss (Barrel version)		1/2 – 14 NPT										S
AISI 316 L ss (Barrel version)		M20 x 1.5 (CM20)										T
AISI 316 L ss (Barrel version)		Pg 13.5										V
AISI 316 L ss (Barrel version)		1/2 GK										U
AISI 316 L ss (Barrel version)		Fieldbus connector				(general purpose only)	(Note 3)					Z
Output/Additional options – 10 th character												
HART digital communication and 4 to 20mA		No additional options					(Notes 4, 5)					H
HART digital communication and 4 to 20mA		Options requested (to be ordered by "Additional ordering code")					(Note 4)					1
PROFIBUS PA		No additional options					(Notes 4, 5)					P
PROFIBUS PA		Options requested (to be ordered by "Additional ordering code")					(Note 5)					2
FOUNDATION Fieldbus		No additional options					(Notes 4, 5)					F
FOUNDATION Fieldbus		Options requested (to be ordered by "Additional ordering code")					(Note 5)					3

2600T Pressure Transmitters

Model 264DR, 264PR, 264HR, 264VR, 264NR

SS/264XR_7

ADDITIONAL ORDERING INFORMATION for model 264HR

Add one or more 2-digit code(s) after the basic ordering information to select all required options

	XX	XX	XX	XX	XX	XX	XX	XX	XX	XX	XX	XX
Electrical certification												
ATEX Group II Category 1 GD – Intrinsic Safety EEx ia	E1											
ATEX Group II Category 1/2 GD – Flameproof EEx d	E2											
ATEX Group II Category 3 GD – Type of protection "N" EEx nL design compliance (Note 6)	E3											
Canadian Standard Association (CSA) (only 1/2–14NPT, M20 and Pg 13.5 electrical connection)	E4											
Standards Australia SAA (Not Ex ia and Ex n for PROFIBUS PA and FOUNDATION Fieldbus)	E5											
Factory Mutual (FM) approval (only with 1/2–14NPT, M20 and Pg 13.5 electrical connection)	E6											
Combined ATEX - Intrinsic Safety and Flameproof	E7											
Combined ATEX, FM and CSA (only with 1/2–14NPT, M20 and Pg 13.5 electrical connection) (Note 6)	EN											
NEPSI (China) - Intrinsic Safety Ex ia	EY											
NEPSI (China) - Flameproof Ex d	EZ											
GOST (Russia) EEx ia	W1											
GOST (Russia) EEx d	W2											
GOST (Kazakhstan) EEx ia	W3											
GOST (Kazakhstan) EEx d	W4											
Inmetro (Brazil) EEx ia	W5											
Inmetro (Brazil) EEx d	W6											
Inmetro (Brazil) EEx nL	W7											
Metrologic (Russia)	WC											
Metrologic (Kazakhstan)	WD											
Output meter												
ProMeter, Standard calibration (Note 6)	D1											
ProMeter, Special calibration (Note 6)	D2											
Analog output indicator linear 0–100% scale (Note 6)	D3											
Analog output indicator, special graduation (to be specified for linear scale) (Note 6)	D5											
Programmable signal meter and HART configurator (CoMeter) (Note 6)	D7											
Programmable signal meter and HART configurator (CoMeter – customer configuration) (Note 6)	D8											
Integral LCD												
Digital LCD integral display											L1	
Mounting bracket (shape and material)												
For pipe mounting (Not suitable for AISI housing) Carbon steel												B1
For pipe mounting AISI 316 L ss												B2
Surge												
Surge/Transient Protector (Internal for HART / 4-20mA)												
Surge/Transient Protector (External supplied loose for PROFIBUS PA and FOUNDATION Fieldbus only suitable with 1/2–14NPT and M20 electrical connection and with ATEX, FM and CSA certifications, no DUST)												S1
Operating manual												
German												M1
Italian												M2
Spanish												M3
French												M4
Labels & tag language												
German												T1
Italian												T2
Spanish												T3
French												T4
Additional tag plate												
Laser printing of tag on stainless steel plate												I2
Configuration												
Standard – Pressure = inH ₂ O/psi at 20° C; Temperature = deg. F												N2
Standard – Pressure = inH ₂ O/psi at 4° C; Temperature = deg. F												N3
Standard – Pressure = inH ₂ O/psi at 20° C; Temperature = deg. C												N4
Standard – Pressure = inH ₂ O/psi at 4° C; Temperature = deg. C												N5
Custom												N6
Certificates												
Inspection certificate EN 10204–3.1 of calibration (9-point)												C1
Certificate of compliance with the order EN 10204–2.1 of instrument design												C6
Material traceability												
Certificate of compliance with the order EN 10204–2.1 of process wetted parts												H1
Inspection certificate EN 10204–3.1 of process wetted parts												H3
Connector												
Fieldbus 7/8 (Recommended for FOUNDATION Fieldbus) - (supplied loose without mating female plug)										(Notes 5, 7)		U1
Fieldbus M12x1 (Recommended for PROFIBUS PA) - (supplied loose without mating female plug)										(Notes 5, 7)		U2
Harting Han – straight entry										(Notes 4, 7)		U3
Harting Han – angle entry										(Notes 4, 7)		U4

2600T Pressure Transmitters

Model 264DR, 264PR, 264HR, 264VR, 264NR

SS/264XR_7

- Note 1: Suitable for oxygen service - NOT AVAILABLE FOR SENSOR V
- Note 2: Not available with sensor code G, H, M, P
- Note 3: Select type in additional ordering code
- Note 4: Not available with Electronic Housing code Z, R, G
- Note 5: Not available with Electronic Housing code P, E
- Note 6: Not available with PROFIBUS PA and FF output code 2 or 3
- Note 7: Not available with Electronic housing code U, S, T, V, H, M, L, N, D, C, A, B

Standard delivery items (can be differently specified by additional ordering code)

- General purpose (no electrical certification)
- No meter/display, no mounting bracket, no surge protection
- English manual and labels
- Configuration with kPa and deg. C units
- No test, inspection or material traceability certificates

THE SELECTION OF SUITABLE WETTED PARTS AND FILLING FLUID FOR COMPATIBILITY WITH THE PROCESS MEDIA IS A CUSTOMER'S RESPONSIBILITY, IF NOT OTHERWISE NOTIFIED BEFORE MANUFACTURING.

2600T Pressure Transmitters

Model 264DR, 264PR, 264HR, 264VR, 264NR

SS/264XR_7

BASIC ORDERING INFORMATION model 264VR Absolute Pressure Transmitter with remote seal

Select one character or set of characters from each category and specify complete catalog number.

Refer to additional ordering information code and specify one or more codes for each transmitter if additional options are required.

BASE MODEL – 1 st to 5 th characters			2	6	4	V	R	X	S	X	X	X	X	X
Absolute Pressure Transmitter with remote seal – BASE ACCURACY 0.075%														
SENSOR - Span limits – 6th character														
0.54 and 16 kPa	5.4 and 160mbar	4 and 120mmHg							E					
0.67 and 40kPa	6.7 and 400mbar	5 and 300 mmHg							F					
1.1 and 65kPa	11 and 650mbar	8 and 480 mmHg							G					
2.67 and 160kPa	26.7 and 1600mbar	20 and 1200 mmHg							H					
10 and 600kPa	0.1 and 6bar	1.45 and 87psi							M					
40 and 2400kPa	0.4 and 24bar	5.8 and 348psi							P					
134 and 8000kPa	1.34 and 80bar	19.4 and 1160psi							Q					
267 and 16000kPa	2.67 and 160bar	38.7 and 2320psi							S					
Use code – 7th character									S					
Diaphragm material / Fill fluid – 8th character														
AISI 316 L ss	Silicone oil	(one seal except union type to be quoted separately)								R				
AISI 316 L ss	Inert fluid-Galden	(one seal except union type to be quoted separately)					(Note 1)			2				
AISI 316 L ss	Inert fluid-Halocarbon	(one seal except union type to be quoted separately)					(Note 1)			W				
Process flanges/adapters material – 9th character														
AISI 316 L ss for seal construction												R		
Bolts – 10th character														
AISI 316 ss (NACE) without gaskets for seal construction								NACE					R	
AISI 316 ss without gaskets for seal construction													S	
Housing material and electrical connection – 11th character														
Aluminium alloy (Barrel version)		1/2 – 14 NPT												A
Aluminium alloy (Barrel version)		M20 x 1.5 (CM 20)												B
Aluminium alloy (Barrel version)		Pg 13.5												D
Aluminium alloy (Barrel version)		1/2 GK												C
Aluminium alloy (Barrel version)		Harting Han connector					(general purpose only)		(Note 2)					E
Aluminium alloy (Barrel version)		Fieldbus connector					(general purpose only)		(Note 2)					G
Aluminium alloy copper-free (Barrel version)		1/2 – 14 NPT												H
Aluminium alloy copper-free (Barrel version)		M20 x 1.5 (CM 20)												L
Aluminium alloy copper-free (Barrel version)		Pg 13.5												N
Aluminium alloy copper-free (Barrel version)		1/2 GK												M
Aluminium alloy copper-free (Barrel version)		Harting Han connector					(general purpose only)		(Note 2)					P
Aluminium alloy copper-free (Barrel version)		Fieldbus connector					(general purpose only)		(Note 2)					R
AISI 316 L ss (Barrel version)		1/2 – 14 NPT												S
AISI 316 L ss (Barrel version)		M20 x 1.5 (CM20)												T
AISI 316 L ss (Barrel version)		Pg 13.5												V
AISI 316 L ss (Barrel version)		1/2 GK												U
AISI 316 L ss (Barrel version)		Fieldbus connector					(general purpose only)		(Note 2)					Z
Aluminium alloy (DIN version)		M20 x 1.5 (CM 20)					(general purpose only)		(Note 4)					J
Aluminium alloy (DIN version)		Pg 13.5					(general purpose only)		(Note 4)					Y
Aluminium alloy (DIN version)		Harting Han connector					(general purpose only)		(Note 2)					K
Output/Additional options – 12th character														
HART digital communication and 4 to 20mA	No additional options							(Notes 3, 4)						H
HART digital communication and 4 to 20mA	Options requested (to be ordered by "Additional ordering code")							(Note 3)						1
PROFIBUS PA	No additional options							(Notes 3, 4)						P
PROFIBUS PA	Options requested (to be ordered by "Additional ordering code")							(Note 4)						2
FOUNDATION Fieldbus	No additional options							(Notes 3, 4)						F
FOUNDATION Fieldbus	Options requested (to be ordered by "Additional ordering code")							(Note 4)						3

2600T Pressure Transmitters

Model 264DR, 264PR, 264HR, 264VR, 264NR

SS/264XR_7

ADDITIONAL ORDERING INFORMATION for model 264VR

Add one or more 2-digit code(s) after the basic ordering information to select all required options

	XX	XX	XX	XX	XX	XX	XX	XX	XX	XX	XX	XX
Electrical certification												
ATEX Group II Category 1 GD – Intrinsic Safety EEx ia	E1											
ATEX Group II Category 1/2 GD – Flameproof EEx d	E2											
ATEX Group II Category 3 GD – Type of protection "N" EEx nL design compliance (Note 5)	E3											
Canadian Standard Association (CSA) (only 1/2–14NPT, M20 and Pg 13.5 electrical connection)	E4											
Standards Australia SAA (Not Ex ia and Ex n for PROFIBUS PA and FOUNDATION Fieldbus)	E5											
Factory Mutual (FM) approval (only with 1/2–14NPT, M20 and Pg 13.5 electrical connection)	E6											
Combined ATEX - Intrinsic Safety and Flameproof	E7											
Combined ATEX, FM and CSA (only with 1/2–14NPT, M20 and Pg 13.5 electrical connection) (Note 5)	EN											
NEPSI (China) - Intrinsic Safety Ex ia	EY											
NEPSI (China) - Flameproof Ex d	EZ											
GOST (Russia) EEx ia	W1											
GOST (Russia) EEx d	W2											
GOST (Kazakhstan) EEx ia	W3											
GOST (Kazakhstan) EEx d	W4											
Inmetro (Brazil) EEx ia	W5											
Inmetro (Brazil) EEx d	W6											
Inmetro (Brazil) EEx nL	W7											
Metrologic (Russia)	WC											
Metrologic (Kazakhstan)	WD											
Output meter												
ProMeter, Standard calibration (Note 5)	D1											
ProMeter, Special calibration (Note 5)	D2											
Analog output indicator linear 0–100% scale (Note 5)	D3											
Analog output indicator, special graduation (to be specified for linear scale) (Note 5)	D5											
Programmable signal meter and HART configurator (CoMeter) (Note 5)	D7											
Programmable signal meter and HART configurator (CoMeter – customer configuration) (Note 5)	D8											
Integral LCD												
Digital LCD integral display										L1		
Mounting bracket (shape and material)												
For pipe mounting (Not suitable for AISI housing) Carbon steel												B1
For pipe mounting (Not suitable for AISI housing) AISI 316 L ss												B2
For wall mounting (Not suitable for AISI housing) Carbon steel												B3
For wall mounting (Not suitable for AISI housing) AISI 316 L ss												B4
Flat type for box AISI 316 L ss												B5
Surge												
Surge/Transient Protector (Internal for HART / 4-20mA)												
Surge/Transient Protector (External supplied loose for PROFIBUS PA and FOUNDATION Fieldbus only suitable with 1/2–14NPT and M20 electrical connection and with ATEX, FM and CSA certifications, no DUST)										S1		
Operating manual												
German												M1
Italian												M2
Spanish												M3
French												M4
Labels & tag language												
German												T1
Italian												T2
Spanish												T3
French												T4
Additional tag plate												
Laser printing of tag on stainless steel plate												I2
Configuration												
Standard – Pressure = inH ₂ O/psi at 20° C; Temperature = deg. F												N2
Standard – Pressure = inH ₂ O/psi at 4° C; Temperature = deg. F												N3
Standard – Pressure = inH ₂ O/psi at 20° C; Temperature = deg.C												N4
Standard – Pressure = inH ₂ O/psi at 4° C; Temperature = deg. C												N5
Custom												N6
Certificates												
Inspection certificate EN 10204–3.1 of calibration (9-point)												C1
Certificate of compliance with the order EN 10204–2.1 of instrument design												C6
Material traceability												
Certificate of compliance with the order EN 10204–2.1 of process wetted parts												H1
Inspection certificate EN 10204–3.1 of process wetted parts												H3
Connector												
Fieldbus 7/8 (Recommended for FOUNDATION Fieldbus) - (supplied loose without mating female plug)										(Notes 4, 6)		U1
Fieldbus M12x1 (Recommended for PROFIBUS PA) - (supplied loose without mating female plug)										(Notes 4, 6)		U2
Harting Han – straight entry										(Notes 3, 6)		U3
Harting Han – angle entry										(Notes 3, 6)		U4

2600T Pressure Transmitters

Model 264DR, 264PR, 264HR, 264VR, 264NR

SS/264XR_7

- Note 1: Suitable for oxygen service
- Note 2: Select type in additional ordering code
- Note 3: Not available with Electronic Housing code Z, R, G
- Note 4: Not available with Electronic Housing code P, E, K
- Note 5: Not available with PROFIBUS PA and FF output code 2 or 3
- Note 6: Not available with Electronic housing code U, S, T, V, H, M, L, N, D, C, A, B, J, Y.

Standard delivery items (can be differently specified by additional ordering code)

- General purpose (no electrical certification)
- No meter/display, no mounting bracket, no surge protection
- English manual and labels
- Configuration with kPa and deg. C units
- No test, inspection or material traceability certificates

THE SELECTION OF SUITABLE WETTED PARTS AND FILLING FLUID FOR COMPATIBILITY WITH THE PROCESS MEDIA IS A CUSTOMER'S RESPONSIBILITY, IF NOT OTHERWISE NOTIFIED BEFORE MANUFACTURING.

2600T Pressure Transmitters

Model 264DR, 264PR, 264HR, 264VR, 264NR

SS/264XR_7

BASIC ORDERING INFORMATION model 264NR Absolute Pressure Transmitter with remote seal

Select one character or set of characters from each category and specify complete catalog number.

Refer to additional ordering information code and specify one or more codes for each transmitter if additional options are required.

BASE MODEL – 1 st to 5 th characters		2	6	4	N	R	X	X	X	X	X	
Absolute Pressure Transmitter with remote seal – BASE ACCURACY 0.075%												
SENSOR - Span limits – 6th character												
1.1 and 65kPa	11 and 650mbar	8 and 480mmHg					G					
2.67 and 160kPa	26.7 and 1600mbar	20 and 1200mmHg					H					
10 and 600kPa	0.1 and 6bar	1.45 and 87psi					M					
40 and 2400kPa	0.4 and 24bar	5.8 and 348psi					P					
134 and 8000kPa	1.34 and 80bar	19.4 and 1160psi					Q					
267 and 16000kPa	2.67 and 160bar	38.7 and 2320psi					S					
Diaphragm material / Fill fluid – 7th character												
AISI 316 L ss		Silicone oil					R					
AISI 316 L ss		Inert fluid-Galden					(Note 1)	2				
AISI 316 L ss		Inert fluid-Halocarbon					(Note 1)	W				
Process connection – 8th character												
Remote seal	(one seal except button and union types to be quoted separately)										R	
Housing material and electrical connection – 9th character												
Aluminium alloy (Barrel version)		1/2 – 14 NPT										A
Aluminium alloy (Barrel version)		M20 x 1.5 (CM 20)										B
Aluminium alloy (Barrel version)		Pg 13.5										D
Aluminium alloy (Barrel version)		1/2 GK										C
Aluminium alloy (Barrel version)		Harting Han connector					(general purpose only)				(Note 3)	E
Aluminium alloy (Barrel version)		Fieldbus connector					(general purpose only)				(Note 3)	G
Aluminium alloy copper-free (Barrel version)		1/2 – 14 NPT										H
Aluminium alloy copper-free (Barrel version)		M20 x 1.5 (CM 20)										L
Aluminium alloy copper-free (Barrel version)		Pg 13.5										N
Aluminium alloy copper-free (Barrel version)		1/2 GK										M
Aluminium alloy copper-free (Barrel version)		Harting Han connector					(general purpose only)				(Note 3)	P
Aluminium alloy copper-free (Barrel version)		Fieldbus connector					(general purpose only)				(Note 3)	R
AISI 316 L ss (Barrel version)		1/2 – 14 NPT										S
AISI 316 L ss (Barrel version)		M20 x 1.5 (CM20)										T
AISI 316 L ss (Barrel version)		Pg 13.5										V
AISI 316 L ss (Barrel version)		1/2 GK										U
AISI 316 L ss (Barrel version)		Fieldbus connector					(general purpose only)				(Note 3)	Z
Output/Additional options – 10th character												
HART digital communication and 4 to 20mA	No additional options									(Notes 4, 5)		H
HART digital communication and 4 to 20mA	Options requested (to be ordered by "Additional ordering code")									(Note 4)		1
PROFIBUS PA	No additional options									(Notes 4, 5)		P
PROFIBUS PA	Options requested (to be ordered by "Additional ordering code")									(Note 5)		2
FOUNDATION Fieldbus	No additional options									(Notes 4, 5)		F
FOUNDATION Fieldbus	Options requested (to be ordered by "Additional ordering code")									(Note 5)		3

2600T Pressure Transmitters

Model 264DR, 264PR, 264HR, 264VR, 264NR

SS/264XR_7

ADDITIONAL ORDERING INFORMATION for model 264NR

Add one or more 2-digit code(s) after the basic ordering information to select all required options

	XX	XX	XX	XX	XX	XX	XX	XX	XX	XX	XX	XX
Electrical certification												
ATEX Group II Category 1 GD – Intrinsic Safety EEx ia	E1											
ATEX Group II Category 1/2 GD – Flameproof EEx d	E2											
ATEX Group II Category 3 GD – Type of protection "N" EEx nL design compliance (Note 6)	E3											
Canadian Standard Association (CSA) (only 1/2–14NPT, M20 and Pg 13.5 electrical connection)	E4											
Standards Australia SAA (Not Ex ia and Ex n for PROFIBUS PA and FOUNDATION Fieldbus)	E5											
Factory Mutual (FM) approval (only with 1/2–14NPT, M20 and Pg 13.5 electrical connection)	E6											
Combined ATEX - Intrinsic Safety and Flameproof	E7											
Combined ATEX, FM and CSA (only with 1/2–14NPT, M20 and Pg 13.5 electrical connection) (Note 6)	EN											
NEPSI (China) - Intrinsic Safety Ex ia	EY											
NEPSI (China) - Flameproof Ex d	EZ											
GOST (Russia) EEx ia	W1											
GOST (Russia) EEx d	W2											
GOST (Kazakhstan) EEx ia	W3											
GOST (Kazakhstan) EEx d	W4											
Inmetro (Brazil) EEx ia	W5											
Inmetro (Brazil) EEx d	W6											
Inmetro (Brazil) EEx nL	W7											
Metrologic (Russia)	WC											
Metrologic (Kazakhstan)	WD											
Output meter												
ProMeter, Standard calibration (Note 6)	D1											
ProMeter, Special calibration (Note 6)	D2											
Analog output indicator linear 0–100% scale (Note 6)	D3											
Analog output indicator, special graduation (to be specified for linear scale) (Note 6)	D5											
Programmable signal meter and HART configurator (CoMeter) (Note 6)	D7											
Programmable signal meter and HART configurator (CoMeter – customer configuration) (Note 6)	D8											
Integral LCD												
Digital LCD integral display										L1		
Mounting bracket (shape and material)												
For pipe mounting (Not suitable for AISI housing)												B1
For pipe mounting												B2
Surge												
Surge/Transient Protector (Internal for HART / 4–20mA)												
Surge/Transient Protector (External supplied loose for PROFIBUS PA and FOUNDATION Fieldbus only suitable with 1/2–14NPT and M20 electrical connection and with ATEX, FM and CSA certifications, no DUST)												S1
Operating manual												
German												M1
Italian												M2
Spanish												M3
French												M4
Labels & tag language												
German												T1
Italian												T2
Spanish												T3
French												T4
Additional tag plate												
Laser printing of tag on stainless steel plate												I2
Configuration												
Standard – Pressure = inH ₂ O/psi at 20° C; Temperature = deg. F												N2
Standard – Pressure = inH ₂ O/psi at 4° C; Temperature = deg. F												N3
Standard – Pressure = inH ₂ O/psi at 20° C; Temperature = deg.C												N4
Standard – Pressure = inH ₂ O/psi at 4° C; Temperature = deg. C												N5
Custom												N6
Certificates												
Inspection certificate EN 10204–3.1 of calibration (9-point)												C1
Certificate of compliance with the order EN 10204–2.1 of instrument design												C6
Material traceability												
Certificate of compliance with the order EN 10204–2.1 of process wetted parts												H1
Inspection certificate EN 10204–3.1 of process wetted parts												H3
Connector												
Fieldbus 7/8 (Recommended for FOUNDATION Fieldbus) - (supplied loose without mating female plug)											(Notes 5, 7)	U1
Fieldbus M12x1 (Recommended for PROFIBUS PA) - (supplied loose without mating female plug)											(Notes 5, 7)	U2
Harting Han – straight entry											(Notes 4, 7)	U3
Harting Han – angle entry											(Notes 4, 7)	U4

2600T Pressure Transmitters

Model 264DR, 264PR, 264HR, 264VR, 264NR

SS/264XR_7

Note 1: Suitable for oxygen service

Note 2: Not used

Note 3: Select type in additional ordering code

Note 4: Not available with Electronic Housing code Z, R, G

Note 5: Not available with Electronic Housing code P, E

Note 6: Not available with PROFIBUS PA and FF output code 2 or 3

Note 7: Not available with Electronic housing code U, S, T, V, H, M, L, N, D, C, A, B

Standard delivery items (can be differently specified by additional ordering code)

- General purpose (no electrical certification)
- No meter/display, no mounting bracket, no surge protection
- English manual and labels
- Configuration with kPa and deg. C units
- No test, inspection or material traceability certificates

THE SELECTION OF SUITABLE WETTED PARTS AND FILLING FLUID FOR COMPATIBILITY WITH THE PROCESS MEDIA IS A CUSTOMER'S RESPONSIBILITY, IF NOT OTHERWISE NOTIFIED BEFORE MANUFACTURING.

™ Hastelloy C276 is a Cabot Corporation trademark

™ Hastelloy C2000 is an Haynes International trademark

™ Monel is an International Nickel Co. trademark

™ Viton is a Dupont de Nemour trademark

™ DC200 is a Dow Corning Corporation trademark

™ Galden is a Montefluos trademark

™ Halocarbon is a Halocarbon Products Co. trademark

™ AN140 is a Wacker-Chemie trademark

™ Neobee M20 is a Stepan Company trademark

™ Marcol is a Esso Italiana trademark

™ Syltherm is a Dow Chemical Company trademark

2600T Pressure Transmitters

Model 264DR, 264PR, 264HR, 264VR, 264NR

ABB has Sales & Customer Support expertise in over 100 countries worldwide

www.abb.com/instrumentation

The Company's policy is one of continuous product improvement and the right is reserved to modify the information contained herein without notice.

Printed in Italy (12.08)

© ABB 2008



ABB Ltd
Howard Road, St. Neots
Cambridgeshire, PE19 8EU
UK
Tel: +44(0)1480 475321
Fax: +44(0)1480 217948

ABB Inc.
125 E. County Line Road
Warminster, PA 18974
USA
Tel: +1 215 674 6000
Fax: +1 215 674 7183

ABB SACE
A division of ABB S.p.A.
Via Statale 113
22016 Lenno (CO) Italy
Tel: +39 0344 58111
Fax: +39 0344 56278