

Model 266DLH Liquid level interface transmitter

2600T Series Pressure Transmitters Engineered solutions for all applications



Base accuracy

- 0.10 % of calibrated span

Reliable sensing system coupled with very latest digital technologies

Specific design for low pressure

- optimize in-use total performance and stability

Flexible configuration facilities

- provided locally via local LCD keypad

New TTG (Through-The-Glass) keypad technology

- allows quick and easy local configuration without opening the cover, even in explosion proof environments

IEC 61508 certification

- for SIL2 (1001) and SIL3 (1002) applications

PED compliance to sound engineering practice (SEP)

Model 266DLH Liquid level interface transmitter

General description

Model 266DLH is an “application specific” transmitter using a differential design for liquid level interface and density measurements, typically for two non-mixable liquids (one upon the other) of different specific gravity, in a tank.

The transmitter has a defined structure with two seals:

- one direct mount flanged flush diaphragm seal is on the high pressure side
- one remote seal, selectable wafer or flanged flush diaphragm, is fitted via capability to the low pressure side.

The seals should have the same physical characteristics (size, materials, etc.) for the two sides; these are suitable to interface tank nozzle of 2 in. / 3in. to ASME or DN 50 / DN80 to EN.

Functional Specifications

Range and span limits

Sensor Code	Upper Range Limit (URL)	Lower Range Limit (LRL)	Minimum span	Compatibility (allowed seal) Direct mount and one remote seal (max length in m)
B	4 kPa 40 mbar 16 inH2O	-4 kPa -40 mbar -16 inH2O	0.4 kPa 4 mbar 1.6 inH2O	3in/DN80 wafer or flanged flush diaphragm seal (2)
E	16 kPa 160 mbar 64 inH2O	-16 kPa -160 mbar -64 inH2O	1.6 kPa 16 mbar 6.4 inH2O	2in/DN50 wafer or flanged flush diaphragm seal (2) 3in/DN80 wafer or flanged flush diaphragm seal (4)

Span limits

Maximum span = URL

IT IS RECOMMENDED TO SELECT THE TRANSMITTER SENSOR CODE PROVIDING THE TURNDOWN VALUE AS LOWEST AS POSSIBLE TO OPTIMIZE PERFORMANCE CHARACTERISTICS.

Zero suppression and elevation

Zero and span can be adjusted to any value within the range limits detailed in the table as long as:

- calibrated span \geq minimum span

Damping

Selectable time constant : between 0 and 60 s

This is in addition to sensor response time.

Turn on time

Operation within specification in less than 10 s with minimum damping.

Insulation resistance

> 100 M Ω at 500 V DC (terminals to earth)

Operative limits

Pressure limits:

Overpressure limits

Without damage to the transmitter

Model 266DLH	Fill fluid	Overpressure limits
Sensor B	Silicone oil	0.07 kPa abs, 0.7 mbar abs, 0.5 mmHg and 7 MPa, 70 bar, 1015 psi
Sensor E	Silicone oil	0.07 kPa abs, 0.7 mbar abs, 0.5 mmHg and 16 MPa, 160 bar, 2320 psi
Sensor B	Inert (Galden)	0.135 kPa abs, 1.35 mbar abs, 1 mmHg and 7 MPa, 70 bar, 1015 psi
Sensor E	Inert (Galden)	0.135 kPa abs, 1.35 mbar abs, 1 mmHg and 16 MPa, 160 bar, 2320 psi

Static pressure limits

Transmitters for differential pressure model 266DLH operates within specifications between the following limits:

Sensors	Static pressure limits
Sensor B	Atmosphere and 7 MPa, 70 bar, 1015 psi
Sensor E	Atmosphere and 16 MPa, 160 bar, 2320 psi

Proof pressure

The transmitter can be exposed without leaking to line pressure of up to 28 MPa, 280 bar, 4000 psi or two times the flange rating of seal, whichever is less.

Meet ANSI/ISA-S 82.03 hydrostatic test requirements.

Overpressure and static upper limit can be derated by the flange rating of seal, as follows

Rating to EN 1092-1	Carbon steel flange @ 120 °C	AISI 316 ss flange @ 20 °C
PN 16	16 bar	16 bar
PN 40	40 bar	40 bar

Rating to ASME B16.5	Carbon Steel @ 100 °F (38 °C)	AISI 316 ss flange @ 100 °F (38 °C)
Class 150	285 psi	275 psi
Class 300	740 psi	720 psi

Temperature limits °C (°F) :

Ambient

is the operating temperature

Model 266DLH	Ambient temperature limits
Silicone oil	-20 and 85 °C (-4 and 185 °F)
Inert (Galden)	-10 and 85 °C (14 and 185 °F)

Model 266DLH	Ambient temperature limits
LCD integral display	-40 and 85 °C (-40 and 185 °F)

LCD display may not be clearly readable below -20 °C (-4 °F) or above +70 °C (+158 °F)

IMPORTANT

For Hazardous Atmosphere applications see the temperature range specified on the certificate/approval relevant to the aimed type of protection

Storage

Models 266DLH	Storage temperature limits
Storage limits	-50 and 85 °C (-58 and 185 °F)
LCD integral display	-40 and 85 °C (-40 and 185 °F)

Process

The following table show characteristics of fill fluids for 266DLH

FILL FLUID CHARACTERISTICS

Fill fluid (application)	Process temperature and pressure limits				Specifications @ 25 °C (77°F)		
	Tmax @ Pabs > of	Pmin mbar abs (mmHg)	Tmax @ Pmin	Tmin	Specific gravity (kg/dm3)	Kinematic viscosity (cst)	Thermal expansion (x 10-3 /°C)
Silicone oil DC 200 5 cSt	150 (302) @ 0.7 mbar	0.7 (0.5)	100 (212)	-20 (-4)	0.91	5	1.15
Inert oil Galden G5 (oxygen service)	100 (212) @ 75 mbar	2.1 (1.52)	60 (140)	-10 (14)	1.82	4.4	1.1

Absolute viscosity (cP) = Kinematic Viscosity (cSt) x Specific gravity at specified temperature.

The absolute viscosity value is used for response time calculation.

Model 266DLH Liquid level interface transmitter

Environmental limits

Electromagnetic compatibility (EMC)

Comply with EN 61326 and NAMUR NE-21
Surge immunity level (with surge protector): 4 kV
(according to IEC 1000-4-5 EN 61000-4-5)

Pressure equipment directive (PED)

Comply with 97/23/EEC following sound engineering practice (SEP).

Humidity

Relative humidity: up to 100 %
Condensing, icing: admissible

Vibration resistance

Accelerations up to 2 g at frequency up to 1000 Hz
(according to IEC 60068-2-6)

Shock resistance

Acceleration: 50 g
Duration: 11 ms
(according to IEC 60068-2-27)

Wet and dust-laden atmospheres

The transmitter is dust and sand tight and protected against immersion effects as defined by EN 60529 (1989) to IP 67 (IP 68 on request) or by NEMA to 4X or by JIS to C0920. IP65 with Harting Han connector.

Hazardous atmospheres

With or without integral display

INTRINSIC SAFETY:

ATEX Europe (code E1) and IEC Ex (code E8) approval

II 1 G Ex ia IIC T6/T5/T4 and

II 1/2 G Ex ia IIC T6/T5/T4; IP67.

II 1 D Ex iaD 20 T85 °C and

II 1/2 D Ex iaD 21 T85 °C; IP67.

NEPSI China (code EY)

Ex ia IIC T4~T6, DIP A20TA, T4~T6.

EXPLOSION PROOF:

ATEX Europe (code E2) and IEC Ex (code E9) approval

II 1/2 G Ex d IIC T6 and

II 1/2 D Ex tD A21 T85 °C (-50 °C ≤ Ta ≤ +75 °C); IP67.

NEPSI China (code EZ)

Ex d IIC T6, DIP A21TA, T6.

TYPE "N":

ATEX Europe (code E3) and IEC Ex (code ER) type examination

II 3 G Ex nL IIC T6/T5/T4 and

II 3 D Ex tD A22 T85 °C; IP67.

NEPSI China (code ES) type examination

Ex nL IIC T4~T6, DIP A22TA, T6.

FM Approvals US (code E6) and

FM Approvals Canada (code E4):

– Explosionproof (US): Class I, Div. 1, Groups A, B, C, D

– Explosionproof (Canada): Class I, Div. 1, Groups B, C, D

– Dust ignitionproof : Class II, Div. 1, Groups E, F, G

– Suitable for: Class II, Div. 2, Groups F, G; Class III, Div.1, 2

– Nonincendive: Class I, Div. 2, Groups A, B, C, D

– Intrinsically safe: Class I, II, III, Div. 1, Groups A, B, C, D, E, F, G

Class I, Zone 0 AEx ia IIC T6/T4, Zone 0 (FM US)

Class I, Zone 0 Ex ia IIC T6/T4, Zone 0 (FM Canada)

COMBINED ATEX (code EW = E1 + E2 + E3), (code E7 = E1 + E2)

COMBINED ATEX and FM Approvals (code EN = EW + E4 + E6)

COMBINED FM Approvals US and Canada

– Intrinsically safe (code EA)

– Explosionproof (code EB)

– Nonincendive (code EC)

COMBINED IEC (code EH = E8 + E9), (code EI = E8 + E9 + ER)

COMBINED NEPSI (code EP = EY + EZ), (code EQ = EY + EZ + ES)

– GOST (Russia), GOST (Kazakhstan), Inmetro (Brazil)

based on ATEX

REFER TO CERTIFICATES FOR AMBIENT TEMPERATURE RANGES (WITHIN THE LIMITS OF -50 TO 85°C) RELATED TO THE DIFFERENT TEMPERATURE CLASSES

Electrical Characteristics and Options

HART digital communication and 4 to 20 mA output Power Supply

The transmitter operates from 10.5 to 42 V DC with no load and is protected against reverse polarity connection (additional load allows operations over 42 V DC).

For EEx ia and other intrinsically safe approval power supply must not exceed 30 V DC.

Minimum operating voltage increase to 12.3 V DC with optional surge protector

Ripple

20 mV max on a 250 Ω load as per HART specifications.

Load limitations

4 to 20 mA and HART total loop resistance :

$$R \text{ (k}\Omega\text{)} = \frac{\text{Supply voltage} - \text{min. operating voltage (V DC)}}{22 \text{ mA}}$$

A minimum of 250 Ω is required for HART communication.

Optional indicators

Integral display (code L1)

Wide screen LCD, 128 x 64 pixel,

52.5 x 27.2 mm (2.06 x 1.07 in.) dot matrix. Multilanguage.

Four keys for configuration and management of device.

Easy setup for quick commissioning.

User selectable application-specific visualizations.

Totalized and instantaneous flow indication.

Display may also indicate static pressure, sensor temperature and diagnostic messages and provides configuration facilities.

Through-the-glass (TTG) controlled display (code L5)

As above integral display but equipped with the innovative TTG keypad allowing the activation of the configuration and management menus of the device without the need of removing the transmitter housing cover.

TTG keypad is protected against accidental activations.

Optional surge protection

Up to 4kV

– voltage 1.2 μs rise time / 50 μs delay time to half value

– current 8 μs rise time / 20 μs delay time to half value

Output signal

Two-wire 4 to 20 mA, user-selectable for linear or square root output, power of $\sqrt[3]{2}$ or $\sqrt[5]{2}$, square root for bidirectional flow, 22 points linearization table (i.e. for horizontal or spherical tank level measurement).

HART® communication provides digital process variable superimposed on 4 to 20 mA signal, with protocol based on Bell 202 FSK standard.

Output current limits (to NAMUR standard)

Overload condition

- Lower limit: 3.8 mA (configurable from 3.8 to 4 mA)

- Upper limit: 20.5 mA (configurable from 20 to 21 mA)

Alarm current

- Lower limit: 3.6 mA (configurable from 3.6 to 4 mA)

- Upper limit: 21 mA (configurable from 20 to 22 mA)

Factory setting: high alarm current

Process diagnostics (PILD)

Plugged impulse line detection (PILD) generates a warning via HART communication. The device can also be configured to drive the analog output signal to the "Alarm current".



Model 266DLH Liquid level interface transmitter

FOUNDATION Fieldbus output

Device type

LINK MASTER DEVICE

Link Active Scheduler (LAS) capability implemented.

Manufacturer code: 000320 (hex)

Device type code: 0007 (hex)

Power supply

The transmitter operates from 9 to 32 V DC, polarity independent, with or without surge protector.

For EEx ia approval power supply must not exceed 24 V DC (entity certification) or 17.5 V DC (FISCO certification), according to FF-816.

Current consumption

operating (quiescent): 15 mA

fault current limiting: 20 mA max.

Output signal

Physical layer in compliance to IEC 1158-2/EN 61158-2 with transmission to Manchester II modulation, at 31.25 kbit/s.

Function blocks/execution period

3 enhanced Analog Input blocks/25 ms max (each)

1 enhanced PID block/40 ms max.

1 standard ARithmetic block/25 ms

1 standard Input Selector block/25 ms

1 standard Control Selector block/25 ms

1 standard Signal Characterization block/25 ms

1 standard Integrator/Totalizer block/25 ms

Additional blocks

1 enhanced Resource block,

1 custom Pressure with calibration transducer block

1 custom Advanced Diagnostics transducer block including

Plugged Input Line Detection

1 custom Local Display transducer block

Number of link objects

35

Number of VCRs

35

Output interface

FOUNDATION fieldbus digital communication protocol to standard H1, compliant to specification V. 1.7.

Integral display

Wide screen LCD, 128 x 64 pixel,

52.5 x 27.2 mm (2.06 x 1.07 in.) dot matrix. Multilanguage.

Four keys for configuration and management of device.

Easy setup for quick commissioning.

User selectable application-specific visualizations.

Totalized and instantaneous flow indication.

Display may also indicate static pressure, sensor temperature and diagnostic messages and provides configuration facilities.

Transmitter failure mode

The output signal is “frozen” to the last valid value on gross transmitter failure condition, detected by self-diagnostics which also indicate a BAD conditions. If electronic failure or short circuit occur the transmitter consumption is electronically limited at a defined value (20 mA approx), for safety of the network.

PROFIBUS PA output

Device type

Pressure transmitter compliant to Profiles 3.0.1
Identification number: 3450 (hex)

Power supply

The transmitter operates from 9 to 32 V DC , polarity independent, with or without surge protector.
For EEx ia approval power supply must not exceed 17.5 V DC.
Intrinsic safety installation according to FISCO model.

Current consumption

operating (quiescent): 15 mA
fault current limiting: 20 mA max.

Output signal

Physical layer in compliance to IEC 1158–2/EN 61158–2 with transmission to Manchester II modulation, at 31.25 kbit/s.

Output interface

PROFIBUS PA communication according to Profibus DP50170 Part 2/DIN 19245 part 1–3.

Output update time

25 ms

Data blocks

3 analog input, 1 physical.

Additional blocks

1 Pressure with calibration transducer block
1 Advanced Diagnostics transducer block including Plugged Input Line Detection
1 Local Display transducer block

Integral display

Wide screen LCD, 128 x 64 pixel,
52.5 x 27.2 mm (2.06 x 1.07 in.) dot matrix. Multilanguage.
Four keys for configuration and management of device.
Easy setup for quick commissioning.
User selectable application-specific visualizations.
Instantaneous flow indication.
Display may also indicate static pressure, sensor temperature and diagnostic messages and provides configuration facilities.

Transmitter failure mode

On gross transmitter failure condition, detected by self-diagnostics, the output signal can be driven to defined conditions, selectable by the user as safe, last valid or calculated value.
If electronic failure or short circuit occur the transmitter consumption is electronically limited at a defined value (20 mA approx), for safety of the network.

Model 266DLH Liquid level interface transmitter

Performance specifications

Stated at reference condition to IEC 60770 ambient temperature of 20 °C (68 °F), relative humidity of 65 %, atmospheric pressure of 1013 hPa (1013 mbar), mounting position with vertical diaphragm and zero based range for transmitter with isolating diaphragms in AISI 316 L ss or Hastelloy and silicone oil fill and HART digital trim values equal to 4 mA and to 20 mA span end points, in linear mode. Unless otherwise specified, errors are quoted as % of span. Some performance referring to the Upper Range Limit are affected by the actual turndown (TD) as ratio between Upper Range Limit (URL) and calibrated span.

IT IS RECOMMENDED TO SELECT THE TRANSMITTER SENSOR CODE PROVIDING THE TURNDOWN VALUE AS LOWEST AS POSSIBLE TO OPTIMIZE PERFORMANCE CHARACTERISTICS.

Accuracy rating

% of calibrated span, including combined effects of terminal based linearity, hysteresis and repeatability. For fieldbus versions SPAN refer to analog input function block outscale range

Model	for TD up to	
266DLH	from 1:1 to 5:1	± 0.10 %
	from 5:1 to 10:1	± (0.02 x TD) %

Ambient temperature

per 20K (36°F) ambient temperature change on transmitter sensor between the limits of -20°C to +65°C (-4 to +150°F) and per 20K (36°F) process temperature change on seals diaphragm between the process operating temperature limits

Model	Sensor	seal size	
266DLH	B	3 in. / DN 80	0.01 kPa, 0.1 mbar, 0.04 inH2O
266DLH	E	2 in. / DN 50	0.03 kPa, 0.3 mbar, 0.12 inH2O
266DLH	E	3 in. / DN 80	0.02 kPa, 0.2 mbar, 0.08 inH2O

Static pressure

(zero errors can be calibrated out at line pressure)

per 1 MPa, 10 bar or 145 psi

Sensor code B

- zero error: ±0.15% of URL
- span error: ±0.15% of reading

Sensor code E

- zero error: ±0.08% of URL
- span error: ±0.08% of reading

Supply voltage

Within voltage/load specified limits the total effect is less than 0.005 % of URL per volt.

Load

Within load/voltage specified limits the total effect is negligible.

Electromagnetic field

Meets all the requirements of EN 61326 and NAMUR NE-21.

Common mode interference

No effect from 100Vrms @ 50Hz, or 50 V DC

Physical Specification

(Refer to ordering information sheets for variant availability related to specific model or versions code)

Materials

Process isolating diaphragm (seals) (*)

AISI 316 L ss; Hastelloy C-276™.

Fill fluid (seals)

Silicone oil-DC200™; Inert-Galden™.

Bolts and nuts

AISI 316 ss bolts and nuts Class A4–50 per UNI 7323 (ISO 3506), in compliance with NACE MR0175 Class II.

Sensor fill fluid

Silicone oil; Inert fill (Galden™).

Sensor housing

AISI 316 L ss.

Electronic housing and covers

Aluminium alloy (copper content ≤ 0.3 %) with baked epoxy finish (colour RAL9002);

AISI 316 L ss.

Covers O-ring

Buna N.

Local adjustments (zero, span and write protect)

Glass filled polyphenylene oxyde (removable).

Plates

AISI 316ss for transmitter nameplate, certification plate, optional tag/calibration plate attached to the electronics housing and optional wired-on customer data plate. All printing by laser.

Calibration

Standard: at maximum span, zero based range, ambient temperature and pressure;

Optional: at specified range and ambient conditions.

Optional extras

Display

4-position (at 90°) user orientable.

Optional plates

Code I2: for tag (up to 31 characters) and calibration details (up to 31 characters: lower and upper values plus unit) fixed onto transmitter housing.

Code I1: for customer data (32 character x 4 lines) wired-on transmitter housing

Surge protection

Test Certificates (test, design, calibration, material traceability)

Tag and manual language

Communication connectors

Model 266DLH Liquid level interface transmitter

Process connections

Flush diaphragm flanged seal (**):

2 in. or 3 in. ASME 150 or 300 RF;
DN 50 or DN 80 PN 16–40,

Wafer seal (remote only and with backup flange not supplied)

2 in. or 3 in. to ASME; DN 50 or DN 80 to EN.

Gasket seat finish

serrated (ASME): 3.2 to 6.3 μ m (Ra)

serrated (EN 1092-1 Type B1): 3.2 to 12.5 μ m (Ra)

Electrical connections

Two 1/2 – 14 NPT or M20x1.5 threaded conduit entries, direct on housing.

Special communication connector (on request)

– HART : straight or angle Harting Han 8D connector and one plug.

– FOUNDATION Fieldbus, PROFIBUS PA: M12x1 or 7/8 in.

Terminal block

HART version: three terminals for signal/external meter wiring up to 2.5 mm² (14 AWG), also connection points for test and communication purposes.

Fieldbus versions: two terminals for signal wiring (bus connection) up to 2.5 mm² (14 AWG)

Grounding

Internal and external 6 mm² (10 AWG) ground termination points are provided.

Mounting position

Transmitter can be mounted in any position.

Electronics housing may be rotated to any position. A positive stop prevents over travel.

Mass (without options)

9 kg to 12 kg approx (20 to 27 lb) according to specified seal(s) options; add 1.5 kg (3.4 lb) for AISI housing.

Add 650 g (1.5 lb) for packing.

Packing

Carton

Configuration

Transmitter with HART communication and 4 to 20 mA Standard configuration

Transmitters are factory calibrated to customer's specified range. Calibrated range and tag number are stamped on the tag plate. If a calibration range and tag data are not specified, the transmitter will be supplied with the plate left blank and configured as follows:

Engineering Unit	kPa
4 mA	Zero
20 mA	Upper Range Limit (URL)
Output	Linear
Damping	1 s
Transmitter failure mode	Upscale
Software tag (8 characters max)	Blank
Optional LCD display	PV in kPa; output in mA and in percentage on bargraph

Any or all the above configurable parameters, including Lower range-value and Upper range-value which must be the same unit of measure, can be easily changed using the HART hand-held communicator or by a PC running the configuration software with DTM for 266 models. The transmitter database is customized with specified flange type and material, O-ring and drain/vent materials and meter code option.

Custom configuration (option N6)

The following data may be specified in addition to the standard configuration parameters:

Descriptor	16 alphanumeric characters
Message	32 alphanumeric characters
Date	Day, month, year

For HART protocol available engineering units of pressure measure are :

Pa, kPa, MPa

inH₂O@4 °C, mmH₂O@4 °C, psi

inH₂O@20 °C, ftH₂O@20 °C, mmH₂O@20 °C

inHg, mmHg, Torr

g/cm², kg/cm², atm

mbar, bar

These and others are available for PROFIBUS and FOUNDATION Fieldbus.

(*) Wetted parts of the transmitter.

(**) Bolts and nuts, gasket and mating flange supplied by customer.

Transmitter with PROFIBUS PA communication

Standard configuration

Transmitters are factory calibrated to customer's specified range. Calibrated range and tag number are stamped on the tag plate. If a calibration range and tag data are not specified, the transmitter will be supplied with the plate left blank and configured as follows:

Measure Profile	Pressure
Engineering Unit	kPa
Output scale 0 %	Lower Range Limit (LRL)
Output scale 100 %	Upper Range Limit (URL)
Output	Linear
Hi-Hi Limit	Upper Range Limit (URL)
Hi Limit	Upper Range Limit (URL)
Low Limit	Lower Range Limit (LRL)
Low-Low Limit	Lower Range Limit (LRL)
Limits hysteresis	0.5 % of output scale
PV filter	0 s
Address (set by local key)	126
Tag	32 alphanumeric characters
Optional LCD display	PV in kPa; output in percentage on bargraph

Any or all the above configurable parameters, including the range values which must be the same unit of measure, can be easily changed by a PC running the configuration software with DTM for 266 models. The transmitter database is customized with specified flange type and material, O-ring and drain/vent materials and meter code option.

Custom configuration (option N6)

The following data may be specified in addition to the standard configuration parameters:

Descriptor	32 alphanumeric characters
Message	32 alphanumeric characters
Date	Day, month, year

Transmitter with FOUNDATION Fieldbus communication

Standard configuration

Transmitters are factory calibrated to customer's specified range. Calibrated range and tag number are stamped on the tag plate. If a calibration range and tag data are not specified, the transmitter will be supplied with the plate left blank and the analog input function block FB1 is configured as follows:

Measure Profile	Pressure
Engineering Unit	kPa
Output scale 0 %	Lower Range Limit (LRL)
Output scale 100 %	Upper Range Limit (URL)
Output	Linear
Hi-Hi Limit	Upper Range Limit (URL)
Hi Limit :	Upper Range Limit (URL)
Low Limit	Lower Range Limit (LRL)
Low-Low Limit	Lower Range Limit (LRL)
Limits hysteresis	0.5 % of output scale
PV filter time	0 s
Tag	32 alphanumeric characters
Optional LCD display	PV in kPa; output in percentage on bargraph

The analog input function block FB2 and FB3 are configured respectively for the sensor temperature measured in °C and for the static pressure measured in MPa.

Any or all the above configurable parameters, including the range values, can be changed using any host compliant to FOUNDATION fieldbus. The transmitter database is customized with specified flange type and material, O-ring and drain/vent materials and meter code option.

Custom configuration (option N6)

The following data may be specified in addition to the standard configuration parameters:

Descriptor	32 alphanumeric characters
Message	32 alphanumeric characters
Date	Day, month, year

Model 266DLH Liquid level interface transmitter

MOUNTING DIMENSIONS (not for construction unless certified) – dimensions in mm (in.)

266DLH with barrel housing

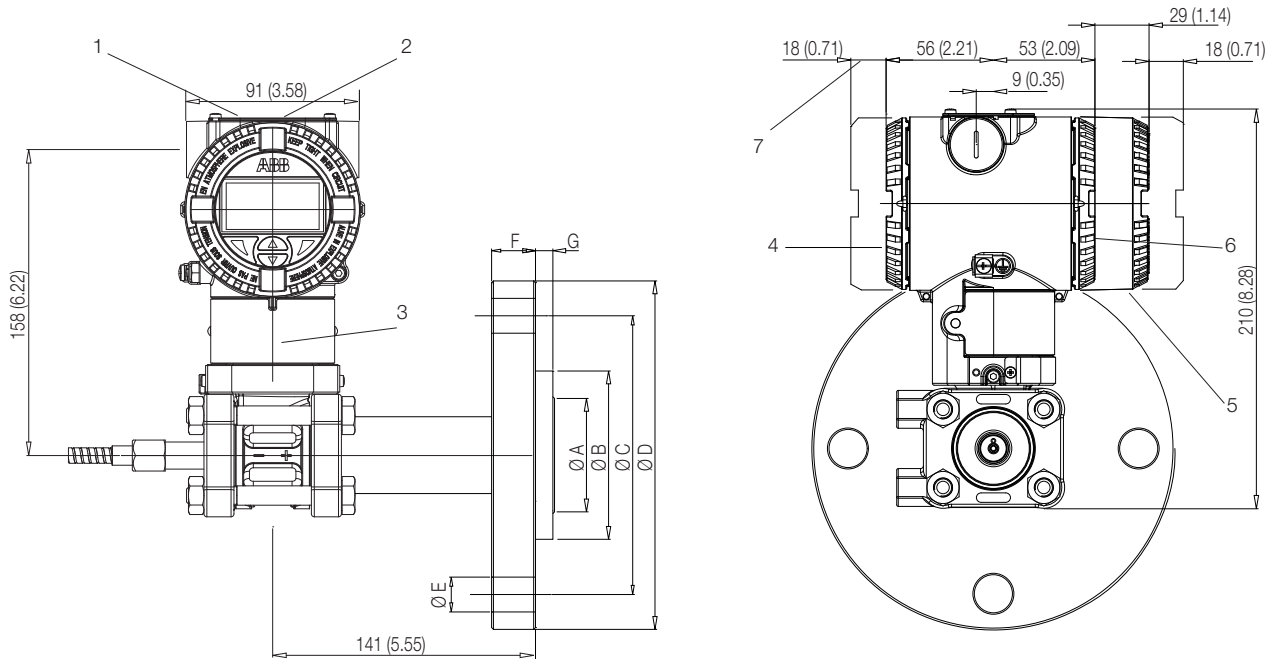

1 Adjustments | 2 Identification plate | 3 Certification plate | 4 Terminal side | 5 Integral display housing | 6 Electronic side | 7 Space for cover removal

Wafer seal (selectable as remote on negative side)

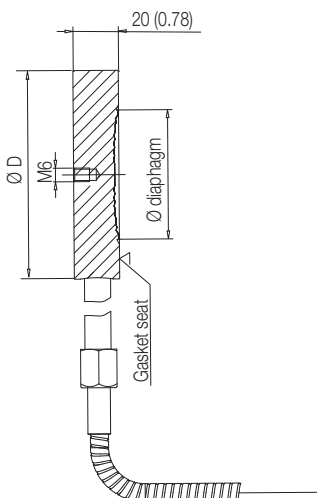

Size/Rating	Dimensions mm (in) for wafer remote seal	
	diaphragm (dia)	D (dia)
2 in. ASME B16.5	60 (2.36)	92 (3.62)
3 in. ASME B16.5	89 (3.5)	127 (5)
DN 50 EN 1092-1 Form B1	60 (2.36)	102 (4.02)
DN 80 EN 1092-1 Form B1	89 (3.5)	138 (5.43)

266DLH with DIN housing

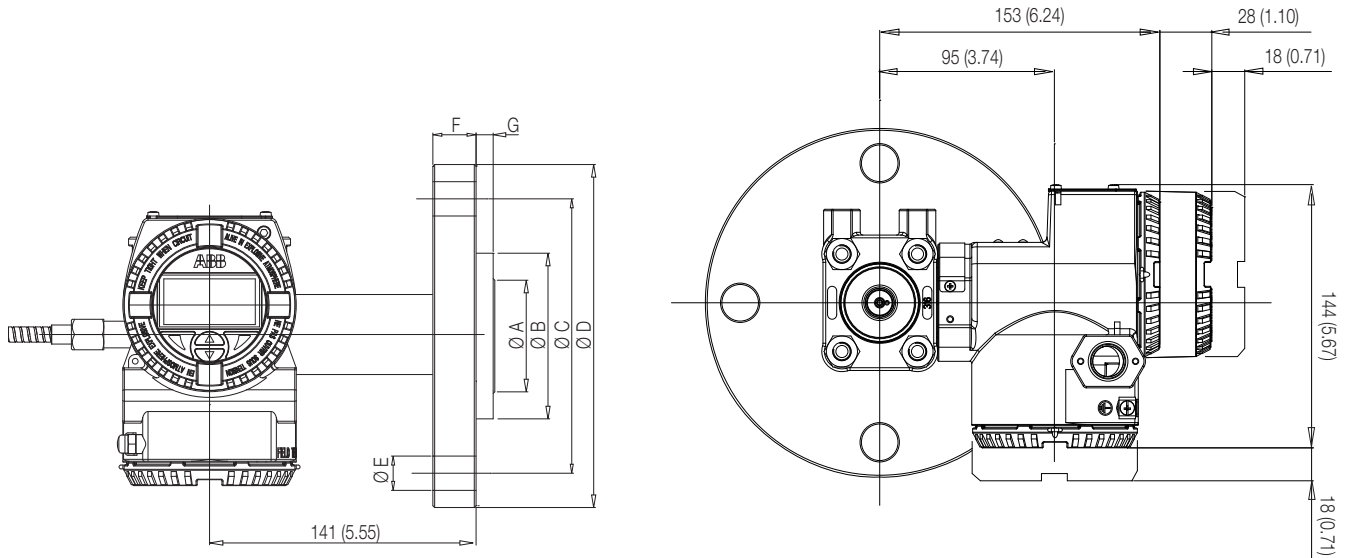

Size/Rating	Dimensions mm (in) for ASME flanged versions							
	A (dia)	B (dia)	C (dia)	D (dia)	E (dia)	F (Note 1)	G	N° of holes
2 in. ASME CL 150	60 (2.36)	92 (3.62)	120.65 (4.75)	152.4 (6)	19.1 (0.79)	17.5 (0.6)	9.5 (0.37)	4
2 in. ASME CL 300	60 (2.36)	92 (3.62)	127 (5)	165.1 (6.5)	19.1 (0.79)	20.8 (0.8)	9.5 (0.37)	8
3 in. ASME CL 150	89 (3.5)	127 (5)	152.4 (6)	190.5 (7.5)	19.1 (0.79)	22.4 (0.88)	9.5 (0.37)	4
3 in. ASME CL 300	89 (3.5)	127 (5)	168.15 (6.62)	209.6 (8.25)	22.4 (0.88)	26.9 (1.1)	9.5 (0.37)	8

Size/Rating	Dimensions mm (in) for EN flanged versions							
	A (dia)	B (dia)	C (dia)	D (dia)	E (dia)	F (Note 2)	G	N° of holes
DN 50 EN PN 16	60 (2.36)	102 (4.02)	125 (4.92)	165 (6.5)	18 (0.71)	15 (0.58)	9.5 (0.37)	4
DN 50 EN PN 40	60 (2.36)	102 (4.02)	125 (4.92)	165 (6.5)	18 (0.71)	18 (0.67)	9.5 (0.37)	4
DN 80 EN PN 16	89 (3.5)	138 (5.43)	160 (6.3)	200 (7.87)	18 (0.71)	17 (0.67)	9.5 (0.37)	8
DN 80 EN PN 40	89 (3.5)	138 (5.43)	160 (6.3)	200 (7.87)	18 (0.71)	21 (0.83)	9.5 (0.37)	8

Note 1 - Flange thickness tolerance is +3.0 / -0.0 mm (+0.12 / 0.0 in.).

Note 2 - Flange thickness tolerance is +1.0 / -1.3 mm (+0.04 / 0.05 in.) up to 18 mm or ±1.5 mm (±0.06 in.) from 18 to 50 mm from 18 to 50 mm.

Model 266DLH Liquid level interface transmitter

Electrical connections

HART Version

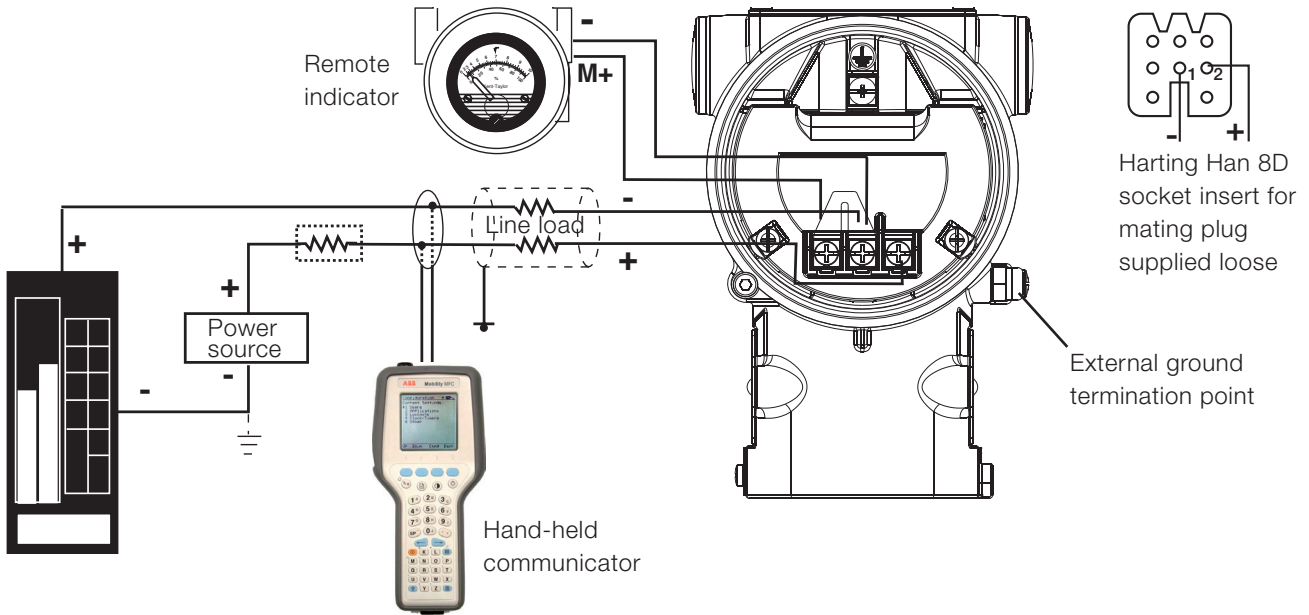

HART hand-held communicator may be connected at any wiring termination point in the loop, providing the minimum resistance is 250 ohm. If this is less than 250 ohm, additional resistance should be added to allow communications.

FIELDBUS Versions

7/8 in connector

M12 x 1 connector

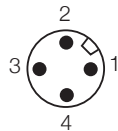

PIN (male) IDENTIFICATION		
	FOUNDATION	PROFIBUS
	Fieldbus	PA
1	DATA -	DATA +
2	DATA +	GROUND
3	SHIELD	DATA -
4	GROUND	SHIELD

CONNECTOR IS SUPPLIED LOOSE
WITHOUT MATING FEMALE PLUG

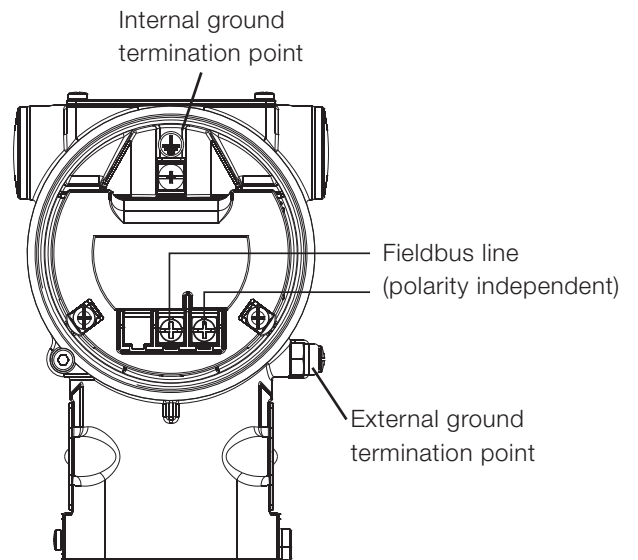

Ordering information

BASIC ORDERING INFORMATION model 266DLH Differential Pressure Transmitter for liquid level interface and density

Select one character or set of characters from each category and specify complete catalog number.

Refer to additional ordering information and specify one or more codes for each transmitter if additional options are required.

BASE MODEL - 1 st to 6 th characters				2 6 6 D L H	X	X	X	X	X	X	X
Liquid level interface and density transmitter – BASE ACCURACY 0.06 %											
SENSOR - Span limits - 7 th characters											
0.4 and 4 kPa	4 and 40 mbar	1.6 and 16 inH2O			B						
1.6 and 16 kPa	16 and 160 mbar	6.4 and 64 inH2O			E						
HIGH PRESSURE SIDE - Size/Mounting flange rating - 8 th characters											
2 in.	ASME CL 150										
2 in.	ASME CL 300										
3 in.	ASME CL 150										
3 in.	ASME CL 300										
DN 50	EN PN 16/40										
DN 80	EN PN 16										
DN 80	EN PN 40										
HIGH PRESSURE SIDE – Mounting flange material/Seat form (seal) - 9 th characters											
Carbon steel	Form RF (raised face)	Serrated finish seat	(Note 1)			NACE					
Carbon steel	EN 1092-1 Type B1	Serrated finish seat	(Note 2)								
AISI 316 ss	Form RF (raised face)	Serrated finish seat	(Note 1)			NACE					
AISI 316 ss	EN 1092-1 Type B1	Serrated finish seat	(Note 2)								

continued
see next page

Model 266DLH Liquid level interface transmitter

BASIC ORDERING INFORMATION model 266DLH DP Transmitter for liquid level interface / density				2	6	D	L	H	X	X	X	X
High and Low pressure side diaphragm material / Fill fluid (wetted parts) (seals) - 10th characters												
AISI 316 L ss	Silicone oil		NACE							S		
Hastelloy C-276™	Silicone oil		NACE							K		
AISI 316 L ss	Inert fluid - Galden	(Note 3)	NACE							A		
Hastelloy C-276™	Inert fluid - Galden	(Note 3)	NACE							F		
Low pressure side seal type and capillary length in m (feet) - 11th characters												
Flanged flush	0.5 (2)											1
Flanged flush	1 (3)											2
Flanged flush	1.5 (5)											3
Flanged flush	2 (7)											4
Flanged flush	2.5 (8)	(Note 4)										5
Flanged flush	3 (10)	(Note 4)										6
Flanged flush	3.5 (12)	(Note 4)										7
Flanged flush	4 (13)	(Note 4)										8
Wafer	0.5 (2)											M
Wafer	1 (3)											N
Wafer	1.5 (5)											Q
Wafer	2 (7)											S
Wafer	2.5 (8)	(Note 4)										T
Wafer	3 (10)	(Note 4)										U
Wafer	3.5 (12)	(Note 4)										V
Wafer	4 (13)	(Note 4)										Z
Housing material and electrical connection - 12th characters												
Aluminium alloy (barrel version)	1/2 – 14 NPT											A
Aluminium alloy (barrel version)	M20 x 1.5 (CM 20)											B
Aluminium alloy (barrel version)	Harting Han 8D connector	(general purpose only)							(Note 5)			E
Aluminium alloy (barrel version)	Fieldbus connector	(general purpose only)							(Note 5)			G
AISI 316 L ss (barrel version)	1/2 – 14 NPT											S
AISI 316 L ss (barrel version)	M20 x 1.5 (CM20)											T
AISI 316 L ss (barrel version)	Fieldbus connector	(general purpose only)							(Note 5)			Z
Aluminium alloy (DIN version)	M20 x 1.5 (CM20)	(not Ex d or XP)										J
Aluminium alloy (DIN version)	Harting Han 8D connector	(general purpose only)							(Note 5)			K
Aluminium alloy (DIN version)	Fieldbus connector	(general purpose only)							(Note 5)			W
Output/Additional options - 13th characters												
HART digital communication and 4 to 20 mA		No additional options							(Notes 6, 7)			H
HART digital communication and 4 to 20 mA		Options requested by “Additional ordering code”							(Note 6)			1
PROFIBUS PA		No additional options							(Notes 6, 7)			P
PROFIBUS PA		Options requested by “Additional ordering code”							(Note 7)			2
FOUNDATION Fieldbus		No additional options							(Notes 6, 7)			F
FOUNDATION Fieldbus		Options requested by “Additional ordering code”							(Note 7)			3
HART and 4 to 20 mA Safety - certified to IEC 61508		No additional options							(Notes 6, 7)			T
HART and 4 to 20 mA Safety - certified to IEC 61508		Options requested by “Additional ordering code”							(Note 6)			8

ADDITIONAL ORDERING INFORMATION for model 266DLH

Add one or more 2-digit code(s) after the basic ordering information to select all required options

	XX	XX	XX
Hazardous area certifications			
ATEX Intrinsic Safety II 1 G and II 1/2 G Ex ia IIC T6; II 1 D Ex iaD 20 T 95 °C and II 1/2D Ex iaD 21 T95 °C	(Notes 6, 7)	E1	
ATEX Explosion Proof Group II Category 1/2 G Ex d IIC T6 and Group II Category 1/2 D Ex tD A21 IP67 T85 °C	(Notes 6, 7, 8)	E2	
ATEX Type „N“ Group II Category 3 G Ex nL IIC T6 and Group II Category 3 D Ex tD A22 IP67 T85 °C	(Notes 6, 7)	E3	
Combined ATEX - Intrinsic Safety, Explosion Proof and Type „N“	(Notes 6, 7, 8)	EW	
Combined ATEX - Intrinsic Safety and Explosion Proof	(Notes 6, 7, 8)	E7	
Combined ATEX, FM Approvals (USA) and FM Approvals (Canada)	(Notes 6, 7, 8)	EN	
FM Approvals (Canada) approval	(Notes 6, 7, 8)	E4	
FM Approvals (USA) approval	(Notes 6, 7, 8)	E6	
FM Approvals (USA and Canada) Intrinsic Safety	(Notes 6, 7)	EA	
FM Approvals (USA and Canada) Explosion Proof	(Notes 6, 7, 8)	EB	
FM Approvals (USA and Canada) Nonincendive	(Notes 6, 7)	EC	
IEC Intrinsic Safety II 1 G and II 1/2 G Ex ia IIC T6; II 1 D Ex iaD 20 T 95 °C and II 1/2D Ex iaD 21 T95 °C;	(Notes 6, 7)	E8	
IEC Explosion Proof Group II Category 1/2 G Ex d IIC T6 and Group II Category 1/2 D Ex tD A21 IP67 T85 °C	(Notes 6, 7, 8)	E9	
IEC Group II Category 3 G Ex nL IIC T6 and Group II Category 3 D Ex tD A22 IP67 T85 °C	(Notes 6, 7)	ER	
Combined IEC - Intrinsic Safety, Explosion Proof and Type „N“	(Notes 6, 7, 8)	EI	
Combined IEC - Intrinsic Safety and Explosion Proof	(Notes 6, 7, 8)	EH	
NEPSI Intrinsic Safety Ex ia IIC T4~T6, DIP A20TA, T4~T6	(Notes 6, 7)	EY	
NEPSI Explosion Proof Ex d IIC T6, DIP A21TA, T6	(Notes 6, 7, 8)	EZ	
NEPSI Type „N“ Ex nL IIC T4~T6, DIP A22TA, TT6	(Notes 6, 7)	ES	
Combined NEPSI - Intrinsic Safety, Explosion Proof and Type „N“	(Notes 6, 7, 8)	EQ	
Combined NEPSI - Intrinsic Safety and Explosion Proof	(Notes 6, 7, 8)	EP	
Other hazardous area certifications			
GOST (Russia) EEx ia	(Notes 6, 7)	W1	
GOST (Russia) EEx d	(Notes 6, 7, 8)	W2	
GOST (Kazakhstan) EEx ia	(Notes 6, 7)	W3	
GOST (Kazakhstan) EEx d	(Notes 6, 7, 8)	W4	
Inmetro (Brazil) EEx ia	(Notes 6, 7)	W5	
Inmetro (Brazil) EEx d	(Notes 6, 7, 8)	W6	
Inmetro (Brazil) EEx nL	(Notes 6, 7)	W7	
Combined Inmetro (Brazil) - Intrinsic Safety, Explosion Proof and Type „N“	(Notes 6, 7, 8)	W8	
Integral LCD			
Digital LCD integral display			L1
TTG (Through-The-Glass) digital LCD controlled display			L5
Surge			
Surge/Transient Protector			S2

Model 266DLH Liquid level interface transmitter

ADDITIONAL ORDERING INFORMATION for model 266DLH	XX	XX	XX	XX	XX
Operating manual (up to 2 different selections allowed)					
German (ONLY FOR HART and PROFIBUS VERSIONS)	M1				
Italian (ONLY FOR HART VERSION)	M2				
Spanish (ONLY FOR HART VERSION)	M3				
French (ONLY FOR HART VERSION)	M4				
English	M5				
Chinese (ONLY FOR HART VERSION)	M6				
Swedish (ONLY FOR HART VERSION)	M7				
Polish (ONLY FOR HART VERSION)	M9				
Turkish (ONLY FOR HART VERSION)	MT				
Plates language					
German		T1			
Italian		T2			
Spanish		T3			
French		T4			
Additional tag plate					
Supplemental wired-on stainless steel plate				I1	
Laser printing of tag on stainless steel plate				I2	
Configuration					
Standard – Pressure = inH2O/ psi at 68 °F; Temperature = deg. F					N2
Standard – Pressure = inH2O/ psi at 39.2 °F; Temperature = deg. F					N3
Standard – Pressure = inH2O/ psi at 20 °C; Temperature = deg. C					N4
Standard – Pressure = inH2O/ psi at 4 °C; Temperature = deg. C					N5
Custom					N6
Certificates (up to 2 different selections allowed)					
Inspection certificate EN 10204–3.1 of calibration (9-point)					C1
Inspection certificate EN 10204–3.1 of the cleanliness stage					C3
Inspection certificate EN 10204–3.1 of helium leakage test of the sensor module					C4
Inspection certificate EN 10204–3.1 of the pressure test					C5
Certificate of compliance with the order EN 10204–2.1 of instrument design					C6
Overfill protection					C9
Printed record of configured data of transmitter					CG
PMI test of wetted parts					CT

ADDITIONAL ORDERING INFORMATION FOR MODEL 266DLH		XX	XX	XX	XX
Approvals					
GOST (Russia) without Ex	(NOT APPLICABLE WITH ANY HAZARDOUS AREA CERTIFICATION)	Y1			
GOST (Kazakhstan) without Ex	(NOT APPLICABLE WITH ANY HAZARDOUS AREA CERTIFICATION)	Y2			
GOST (Belarus) without Ex	(NOT APPLICABLE WITH ANY HAZARDOUS AREA CERTIFICATION)	Y4			
Chinese pattern without Ex	(NOT APPLICABLE WITH ANY HAZARDOUS AREA CERTIFICATION)	Y5			
DNV approval			YA		
Lloyd approval			YB		
Approval for Custody transfer			YC		
Bureau Veritas approval			YD		
Material traceability					
Certificate of compliance with the order EN 10204–2.1 of process wetted parts					H1
Inspection certificate EN 10204–3.1 of process wetted parts					H3
Test report EN 10204–2.2 of pressure bearing and process wetted parts					H4
Connector					
Fieldbus 7/8 in. (Recommended for FOUNDATION Fieldbus) - (supplied loose without mating female plug)		(Notes 7, 9)			U1
Fieldbus M12x1 (Recommended for PROFIBUS PA) - (supplied loose without mating female plug)		(Notes 7, 9)			U2
Harting Han 8D – straight entry - (supplied loose)		(Notes 6, 9)			U3
Harting Han 8D – angle entry - (supplied loose)		(Notes 6, 9)			U4

- Note 1: Not available with EN mounting flange code M, N, L
Note 2: Not available with ASME mounting flange code A, D, B, E
Note 3: Suitable for presence of strong oxidizing agent
Note 4: Not available with 2 in. or DN50 seals size code A, D, M
Note 5: Select type in additional ordering code
Note 6: Not available with Housing code G, Z, W
Note 7: Not available with Housing code E, K
Note 8: Not available with Housing code J, K, W
Note 9: Not available with Housing code A, B, S, T, J

Standard delivery items (can be differently specified by additional ordering code)

- General purpose (no electrical certification)
- No display, no surge protection
- English manual and labels
- Configuration with kPa and deg. C units
- No test, inspection or material traceability certificates

IMPORTANT REMARK FOR ALL MODELS

THE SELECTION OF SUITABLE WETTED PARTS AND FILLING FLUID FOR COMPATIBILITY WITH THE PROCESS MEDIA IS A CUSTOMER’S RESPONSIBILITY, IF NOT OTHERWISE NOTIFIED BEFORE MANUFACTURING.

NACE COMPLIANCE INFORMATION

- (1) The materials of constructions comply with metallurgical recommendations of NACE MR0175/ISO 15156 for sour oil field production environments. As specific environmental limits may apply to certain materials, please consult latest standard for further details. Selected materials also conform to NACE MR0103 for sour refining environments.
- (2) NACE MR-01-75 addresses bolting requirements in two classes:
 - Exposed bolts: bolts directly exposed to the sour environment or buried, encapsulated or anyway not exposed to atmosphere
 - Non exposed bolts: bolts exposed to the atmosphere.
266 bolting identified by “NACE” are in compliance to the requirements of NACE MR-01-75 when considered “exposed bolting”

Contact us

ABB Ltd.

Process Automation

Howard Road
St. Neots
Cambridgeshire PE19 8EU
UK
Tel: +44 (0)1480 475321
Fax: +44 (0)1480 217948

ABB Inc.

Process Automation

125 E. County Line Road
Warminster
PA 18974
USA
Tel: +1 215 674 6000
Fax: +1 215 674 7183

ABB Automation Products GmbH

Process Automation

Schillerstr. 72
32425 Minden
Germany
Tel: +49 551 905 534
Fax: +49 551 905 555

ABB S.p.A.

Process Automation

Via Statale 113
22016 Lenno (CO)
Italy
Tel: +39 0344 58111
Fax: +39 0344 56278

www.abb.com

Note

We reserve the right to make technical changes or modify the contents of this document without prior notice. With regard to purchase orders, the agreed particulars shall prevail. ABB does not accept any responsibility whatsoever for potential errors or possible lack of information in this document.

We reserve all rights in this document and in the subject matter and illustrations contained therein. Any reproduction, disclosure to third parties or utilization of its contents - in whole or in parts - is forbidden without prior written consent of ABB.

Copyright© 2010 ABB
All rights reserved

3KXP300008R1001

TM Hastelloy C-276 is a Cabot Corporation trademark
TM Galden is a Montefluos trademark