

Instrumentation^{IT} 2600T Pressure Transmitter family

User's Manual

364Gx and 364Ax Models



IM364Gx/Ax



Table of Contents

Safety Notes	6
Operator liability	8
Qualified personnel	8
Returning devices	8
Disposal	8
Information on WEEE Directive 2002/96/EC (Waste Electrical and Electronic Equipment)	8
Transport and storage	8
Safety information for electrical installation	8
Safety information for inspection and maintenance	9
Opening the box	11
Identification	11
Nameplate	11
Tag plate	11
Optional Wired on plate (option I2)	12
Handling	12
Storage	12
Installation	13
Preparing for installation	13
Mounting the transmitter	14
Pipe mounting	15
2in Pipe mounting instruction	17
Wall mounting	17
Wall mounting instruction	18
Digital LCD Integral Display positioning	18
Wiring	18
Wiring requirements	19
Protective Earthing	19
Electrical connection	19
Remote Meter wiring	21
Check the installation	22
Apply power	22
Start up	22
Configuration	23
Default configuration	23
Easy Setup	23
HART Configuration	24
Basic Configuration Functions	24
Set the Damping	24
Set the Damping configuration by Digital LCD Integral Display	24
Set the Damping configuration by CoMeter	24
Set the Damping configuration by HHT	24
Set the Damping configuration by PC	24
Set the Units	24
Set the Units by Digital LCD Integral Display	24
Set the Unit by CoMeter/ProMeter	25
Set the Unit configuration by HHT	25
Set the Unit configuration by PC	25
Set the LRV	25
Set the LRV by Local Keys	26
Set the LRV by Digital LCD Integral Display	26
Set the LRV by CoMeter	26
Set the LRV by HHT	26
Set the LRV by PC	26
Set the URV	26
Set the URV by Local Keys	27
Set the URV by Digital LCD Integral Display	27
Set the URV by CoMeter	27
Set the URV by HHT	27
Set the URV by PC	27
Special functions	27
Transfer functions	27
Transfer functions description	28
Linear	28
Polynomial	28
Two Polynomial functions of 2 nd order	29
Set the Transfer function on the transmitter	29
Set the Transfer function on the transmitter by Digital LCD Integral Display	29
Set the Transfer function on the transmitter by CoMeter	29

Set the Transfer function on the transmitter by HHT	29
Set the Transfer function on the transmitter by PC	29
Set the Transfer function on the Meters	29
Set the Transfer function on the Digital LCD Integral Display	30
Set the Transfer function on the Digital LCD Integral Display by HHT	30
Set the Transfer function on the Digital LCD Integral Display by PC	30
Signal simulation (fixed output current)	30
Fixed output current by Digital LCD Integral Display	30
Fixed output current by CoMeter	30
Fixed output current by HHT	30
Fixed output current by PC	30
Hardware settings	31
Write protect mode	31
Change the failsafe direction	31
Software settings	31
Write protect mode	31
Change the failsafe direction	31
Set the Current Output limits	32
Set the Current Output limits on the Digital LCD Integral Display	32
Set the Current Output limits by HHT	32
Set the Current Output limits by PC	32
Operation	33
Digital LCD Integral Display	33
Navigate the Digital LCD Integral Display	33
Digital LCD Integral Display list of menu and submenu functions	33
Digital LCD Integral Display view setting	37
HART Transmitter	38
Accessing Communication data	38
Accessing Communication data by Digital LCD Integral Display	38
Accessing Communication data by CoMeter	39
Accessing Communication data by HHT	39
Accessing Communication data by PC	39
Accessing Operation data	39
Accessing Operation data by Digital LCD Integral Display	39
Accessing Operation data by CoMeter	39
Accessing Operation data by HHT	39
Accessing Operation data by PC	39
Trimming and Calibration Set Up	40
Sensor trim	40
Sensor Zero Trim	40
Sensor Zero trim by CoMeter	40
Sensor Zero trim by HHT	41
Sensor Zero trim by PC	41
Sensor Low Trim	41
Sensor Low trim by Digital LCD Integral Display	41
Sensor Low trim by HHT	41
Sensor Low trim by PC	41
Sensor High trim	41
Sensor High trim by Digital LCD Integral Display	41
Sensor High trim by HHT	41
Sensor High trim by PC	42
Sensor Static trim	42
Static trim by HHT	42
Static trim by PC	42
Calibration	42
Output trimming (Digital to Analog trim)	42
Output trimming by Digital LCD Integral Display	42
Output trimming by CoMeter	42
Output trimming by HHT	42
Output trimming by PC	43
Additional calibration procedures	43
PV scaling	43
PV scaling by Digital LCD Integral Display	43
Set PV scaling by HHT	43
Set PV scaling by PC	43
Removing PV scaling	43
Removing PV scaling by Digital LCD Integral Display	43
Removing PV scaling by HHT	44
Removing PV scaling by PC	44
Zero suppression	44
Zero elevation	44
Reset to Factory trim	44

Reset to Factory Trim by Digital LCD Integral Display	44
Reset to Factory trim by HHT	45
Reset to Factory trimming by PC	45
Software Write Protect	45
Software Write Protect by Digital LCD Integral Display	45
Software Write Protect by HHT	45
Software Write Protect by PC	45
HART Multidrop mode	45
Maintenance	46
Exterior cleaning	46
Field update	46
Replacement and Troubleshooting	47
Dismantling and reassembly	47
Safety information for Dismantling and Reassembly	47
Dismantling	48
Replacement	49
Electronics replacement	49
Data saving in case of replacement	49
Digital LCD Integral Display installation or replacement	49
Troubleshooting	50
Simple fault finding	50
Transmitter diagnostics	51
Diagnostic messages	51
Diagnostics on the Digital LCD Integral Display (Hart version)	51
Diagnostics on the CoMeter	52
Hart version diagnostics on the HHT	52
Hart version diagnostics on thePC	52
Additional Safety Notes	55
Hazardous Area	55
Certificate groups	56
Power supply operative limits	62
PED information integration	62
IP Protection	63
Declarations	63

1. INTRODUCTION

Instruction Manual Structure

The present manual provides information on installing, operating, troubleshooting the 364 pressure transmitter. Every section of the present manual is specifically dedicated to the specific phase of the transmitter lifecycle starting from the receipt of the transmitter and its identification, passing to the installation, to the electrical connections, to the configuration and to the troubleshooting and maintenance operations.

Worldwide Service Support Centers

ABB instrumentation products are supported worldwide by the local ABB Instrumentation branches. In case you fail to get in touch with your country ABB Instrumentation office you may want to get in touch with one of the following center of excellence for ABB Pressure products.

ABB SpA

Via Statale 113
22016 Lenno (Co) – **Italy**
Tel: +39 0344 58111
Fax: +39 0344 56278

ABB Automation Product GmbH
Schillerstrasse 72
D-32425 Minden – **Germany**
Tel: +49 551 905534
Fax: +49 551 905555

ABB Inc.
125 E. County Line Road
Warminster, PA 18974 – **USA**
Tel: +1 215 6746000
Fax: +1 215 6747183

ABB Inc.
3450 Harvester Road
Burlington, Ontario L7N 3W5 – **Canada**
Tel: +1 905 6810565
Fax: +1 905 6812810

ABB Ltd.
14 Mathura Road
121003 Faridabad, Haryana – **India**
Tel: +91 129 2275592
Fax: +91 129 2279692

ABB (China) Ltd.
35/F Raffles City (Office Tower)
268 Xizang Zhong Zu, 200001 Shanghai – **China**
Tel: +86 21 6122 8888
Fax: +86 21 6122 8822

Safety Notes

General Safety Information

The "Safety" section provides an overview of the safety aspects to be observed for operation of the device.

The device has been constructed in accordance with the state of the art and is operationally safe. It has been tested and left the factory in perfect working conditions. The information in the manual, as well as the applicable documentation and certificates, must be observed and followed in order to maintain this condition throughout the period of operation. Full compliance with the general safety requirements must be observed during operation of the device. In addition to the general information, the individual sections in the manual contain descriptions of processes or procedural instructions with specific safety information.

Only by observing all of the safety information you can reduce to the minimum the risk of hazards for personnel and/or environment.

These instructions are intended as an overview and do not contain detailed information on all available models or every conceivable event that may occur during setup, operation, and maintenance work.

For additional information, or in the event of specific problems not covered in detail by these operating instructions, please contact the manufacturer. In addition, ABB declares that the contents of this manual are not part of any prior or existing agreements, commitments, or legal relationships; nor are they intended to amend these.

All obligations of ABB arise from the conditions of the relevant sales agreement, which also contains the solely binding warranty regulations in full. These contractual warranty provisions are neither extended nor limited by the information provided in this manual.



Caution – Risk

Only qualified and authorized specialist personnel should be charged with installation, electrical connection, commissioning, and maintenance of the transmitter.

Qualified personnel are persons who have experience in installation, electrical wiring connection, commissioning, and operation of the transmitter or similar devices, and hold the necessary qualifications such as:

- Training or instruction, i.e., authorization to operate and maintain devices or systems according to safety engineering standards for electrical circuits, high pressures, and aggressive media
- Training or instruction in accordance with safety engineering standards regarding maintenance and use of adequate safety systems

For safety reasons, ABB draws your attention to the fact that only sufficiently insulated tools conforming to DIN EN 60900 may be used.

Since the transmitter may form part of a safety chain, we recommend replacing the device immediately if any defects are detected.

In case of use in H.A. Non sparking tools only must be employed.

In addition, you must observe:

- The relevant safety regulations regarding the installation and operation of electrical systems, e.g., German legal regulations governing technical tools, §3 (Gerätesicherheitsgesetz: German Equipment Safety Act)
- The relevant standards, e.g., DIN 31 000/VDE 1000
- The regulations and guidelines relating to explosion protection, if explosion-proof transmitters have to be installed.



Warning - General risks

The device can be operated at high levels of pressure and with aggressive media.

As a result, serious injury or significant property damage may occur if this device is operated incorrectly.

Improper use

It is prohibited to use the device for the following purposes:

- As a climbing aid, e.g., for mounting purposes
- As a support for external loads, e.g., as a support for pipes, etc.
- Adding material, e.g., by painting over the name plate or welding/soldering on parts
- Removing material, e.g., by drilling the housing.

Repairs, alterations, and enhancements, or the installation of replacement parts, are only permissible as far as these are described in the manual. Approval by ABB must be requested for any activities beyond this scope. Repairs performed by ABB-authorized centers are excluded from this.

Technical limit values

The device is designed for use exclusively within the values stated on the name plates and within the technical limit values specified on the data sheets.

The following technical limit values must be observed:

- The Maximum Working Pressure may not be exceeded.
- The Maximum ambient operating temperature may not be exceeded.
- The Maximum process temperature may not be exceeded.
- The housing protection type must be observed.

Warranty provisions

Using the device in a manner that does not fall within the scope of its intended use, disregarding this manual, using under-qualified personnel, or making unauthorized alterations, releases the manufacturer from any liability for any resulting damage. This makes the manufacturer's warranty null and void.

Plates and symbols**Danger – <Serious damage to health/risk to life>**

The appearance of either of these symbols next to the "Danger" warning indicates that an imminent risk is present. Failure to avoid this will result in death or serious injury.

**Warning – <Bodily injury>**

The appearance of this symbol next to "Warning" indicates a potentially dangerous situation. Failure to avoid this could result in death or serious injury.

**Caution – <Minor injuries>**

The appearance of this symbol next to "Caution" indicates a potentially dangerous situation.

Failure to avoid this could result in minor injuries. This may also be used for property damage warnings.

**Attention – <Property damage>**

This symbol indicates a potentially damaging situation. Failure to avoid this could result in damage to the product or its surrounding area.

**Important**

This symbol indicates operator tips or particularly useful information. It does not indicate a dangerous or damaging situation.

Operator liability

Prior to using corrosive and abrasive materials for measurement purposes, the operator must check the level of resistance of all parts coming into contact with the materials to be measured.

ABB will gladly support you in selecting the materials, but cannot accept any liability in doing so.

The operators must strictly observe the applicable national regulations with regard to installation, function tests, repairs, and maintenance of electrical devices.

Qualified personnel

Installation, commissioning, and maintenance of the device may only be performed by trained specialist personnel who have been authorized by the plant operator. The specialist personnel must have read and understood the manual and comply with its instructions.

Returning devices

Use the original packaging or suitably secure shipping package if you need to return the device for repair or recalibration purposes. Fill out the return form (see the Appendix) and include this with the device.

According to EC guidelines for hazardous materials, the owner of hazardous waste is responsible for its disposal or must observe the following regulations for shipping purposes:

All devices sent back to ABB must be free from any hazardous materials (acids, alkalis, solvents, etc.).

Disposal

ABB actively promotes environmental awareness and has an operational management system that **meets the requirements of DIN EN ISO 9001:2000, EN ISO 14001:2004, and OHSAS 18001**. Our products and solutions are intended to have minimum impact on the environment and persons during manufacturing, storage, transport, use and disposal. This includes the environmentally friendly use of natural resources. ABB conducts an open dialog with the public through its publications.

This product/solution is manufactured from materials that can be reused by specialist recycling companies.

Information on WEEE Directive 2002/96/EC (Waste Electrical and Electronic Equipment)

This product or solution is not subject to the WEEE Directive 2002/96/EC or corresponding national laws (e.g., the ElektroG (Electrical and Electronic Equipment Act) in Germany).

Dispose of the product/solution directly at a specialist recycling facility; do not use municipal garbage collection points for this purpose. According to the WEEE Directive 2002/96/EC, only products used in private applications may be disposed of at municipal garbage facilities. Proper disposal prevents negative effects on people and the environment, and supports the reuse of valuable raw materials.

If it is not possible to dispose of old equipment properly, ABB can accept and dispose of returns for a fee.

Transport and storage

- After unpacking the pressure transmitter, check the device for transport damage.
- Check the packaging material for accessories.
- During intermediate storage or transport, store the pressure transmitter in the original packaging only.

For information on permissible ambient conditions for storage and transport, see "Technical data". Although there is no limit on the duration of storage, the warranty conditions stipulated on the order acknowledgment from the supplier still apply.

Safety information for electrical installation

Electrical connections may only be established by authorized specialist personnel in accordance with the electrical circuit diagrams.

The electrical connection information in the manual must be observed; otherwise, the applicable protection type may be affected.

Ground the measurement system according to requirements.

Safety information for inspection and maintenance**Warning – Risk to persons**

There is no EMC protection or protection against accidental contact when the housing cover is open. There are electric circuits within the housing which are dangerous if touched. Therefore, the auxiliary power must be switched off before opening the housing cover.

**Warning – Risk to persons**

The device can be operated at high pressure and with aggressive media. Any medium that squirts out can cause severe injuries. Depressurize the pipeline/tank before opening the transmitter connection.

Corrective maintenance work may only be performed by trained personnel.

- Before removing the device, depressurize it and any adjacent lines or containers.
- Check whether hazardous materials have been used as materials to be measured before opening the device. Residual amounts of hazardous substances may still be present in the device and could escape when the device is opened.
- Within the scope of operator responsibility, check the following as part of a regular inspection:
 - Pressure-bearing walls/lining of the pressure device
 - Measurement-related function
 - Leak-tightness
 - Wear (corrosion)

Transmitter components overview

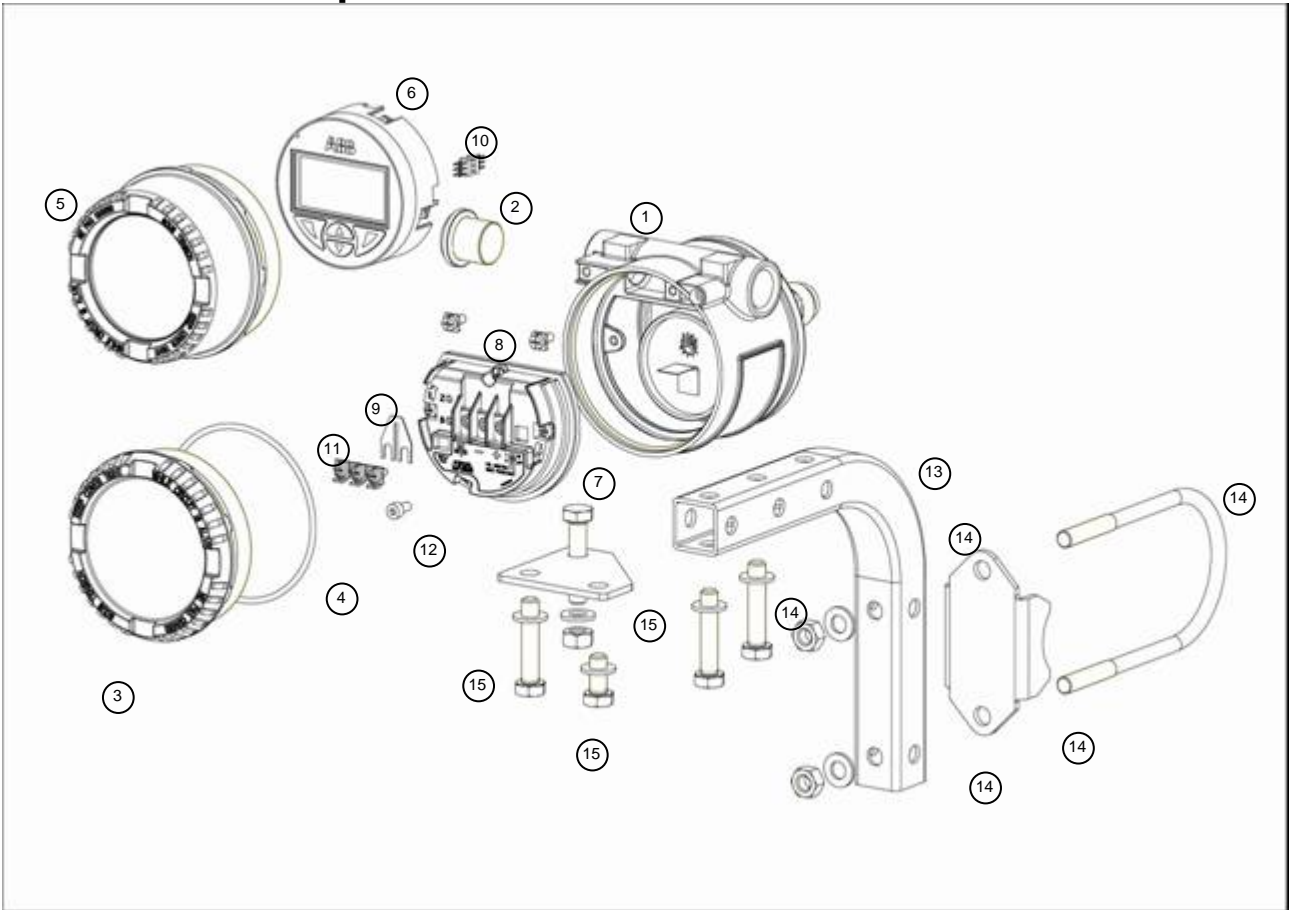

- | | |
|------------------------------------|-----------------------------------|
| 1. Transmitter | 9. Terminal block link |
| 2. Plastic plug | 10. Digital LCD Display connector |
| 3. Blind cover | 11. Terminal block screws |
| 4. Cover gasket | 12. Cover locking screw |
| 5. Window cover | 13. Bracket |
| 6. Digital LCD Integral Display | 14. Tool set for pipe mounting |
| 7. Terminal block with electronics | 15. Tool set for wall mounting |
| 8. Internal grounding screw | |

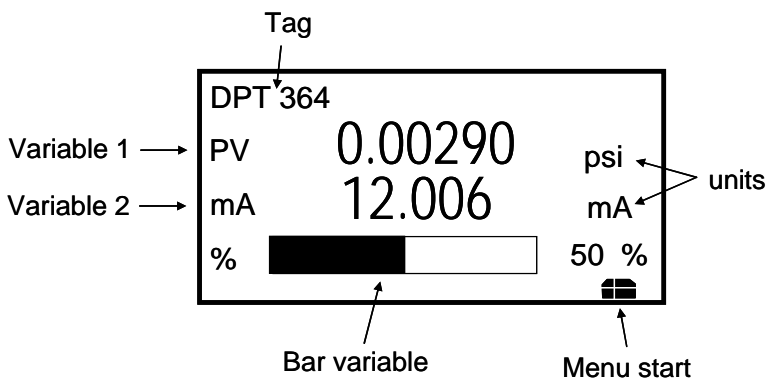

NOTE:

The maximum value that the LCD can display is limited to ± 9999999. The decimal point is positioned automatically so that the maximum value can be displayed as a seven-figure value.

Example of positioning the decimal point:

Setting 0 ... 10000.0 – in this case even smaller values are only displayed with one decimal digit.

- Digital LCD display view -

Opening the box

Transport and storage

- After unpacking the pressure transmitter, check the device for transport damage.
- Check the packing material for accessories.
- During intermediate storage or transport, store the pressure transmitter in the original packaging only.

For information on permissible ambient conditions for storage and transport, see "Technical data". The storage time is indefinite, however, the warranty conditions stipulated in the order confirmation of the supplier are valid.

The transmitter package includes:

- The transmitter
- An envelope including the instruction manual and the calibration report
- 3 mm Allen key
- Optional content depending on the selected options:
 - Bracket kit
 - Electrical connection blind plug





Identification

The instrument is identified by the data plates.

Nameplate

The Nameplate provides information concerning the model code number, maximum working pressure, range and span limits, power supply and output signal. See code/specification sheet for detailed information. This plate also shows:

- the transmitter serial number (please refer to this number in making inquiries)
- the specific details of the transducer (diaphragms material, fill fluid, range limit and identification number)
- the Safety Hazardous Area details (see the specific paragraph in this manual)

 ABB S.p.A. Lenno (Co) Italy	Serial Number	Span Limits	Filling Fluid	 0722
	Code		Diaphragms	
	Output Signal	MWP LRL	URL	
<input type="checkbox"/>	XP CL I/DIV1/ABCD IS Ex ia SEC INTRINSEQUE CL I, ZONE 0, AEx ia IIC T6, T5, T4 IS Ex ia SEC INTRINSEQUE (ENTITY) CL I/DIV1/ABCD when connected per drawing DH 3090 ENCL 4X T AMB=85°C Max. hot spot T4 in 85°C Max AMB DIP CL II/III/DIV1/EFG "Factory Sealed"		<input type="checkbox"/> General Purpose IP67 Max. Supply Voltage 42 Vdc	
<input type="checkbox"/>	XP CL I/DIV1/ABCD IS CL 1, ZONE 0, AEx ia IIC T6, T5, T4 IS (Entity) CL I/DIV1/ABCD when connected per drawing DH 3090 ENCL 4X T AMB=85°C Max. hot spot T4 in 85°C Max AMB "Factory Sealed" DIP CL II/III/DIV1/EFG		<input type="checkbox"/> II 1/2 G Ex d IIC T6 and II 1/2 D Ex tD A21 IP67 T85°C ZELM 06 ATEX 0302X POWER SUPPLY 42 Vdc/ 2W MAX	
			<input type="checkbox"/> II 1 G Ex ia IIC T6 and II 1/2 G Ex ia IIC T6 and II 1D Ex iaD 20 T95°C and II 1/2 D Ex iaD 21 T95°C for electrical parameters see cert. ZELM 06 ATEX 0302X (IP 67)	

Tag plate

An additionally Tag plate, welded to the instrument, provides the customer tag number and the calibrated range.

This plate includes also the code of transmitter with relevant options and the special request code (if any).

 2600T	= High Pressure
Code	
Options	
Spec. Request	Calibration
	TAG

Optional Wired on plate (option I2)

Whenever the transmitter has been ordered with the option I2, a wired on SST plate with 4 lines, 32 characters per line will be supplied. The plate will be wired on the instrument with a SST wire.



Handling

The instrument does not require any special precautions during handling although normal good practice should be observed.

Storage

The instrument does not require any special treatment if stored as dispatched and within the specified ambient conditions (Type 2 to ANSI/ASME N45.2.2-1978). There is no limit to the storage period, although the terms of guarantee remain as agreed with the Company and as given in the order acknowledgement.

Installation

Read carefully these installation instructions before proceeding. Failure to observe the warnings and instructions may cause a malfunction or personal hazard.

**WARNING !**

Before you begin read "Safety" on page 3.

As already specified in the Safety Notes the installation must only be carried out by suitably trained personnel and in accordance with the information given. Any deviation from these instructions, will transfer the complete liability to the user.

It is not recommended to install the transmitter and leave the cover open or the electrical input without the appropriate plugs. Water penetration can damage the electrical circuit.

General

Preparing for installation

Before installing the pressure transmitter, check whether the model meets the measurement and safety requirements of the measuring point. This applies for:

- Measuring range
- Overpressure stability
- Temperature
- Explosion protection
- Operating voltage

The materials must be checked to ensure compatibility with regard to their resistance to the media.

This applies for:

- Gaskets
- Process connections, etc.

In addition, the relevant directives, regulations, standards and accident prevention regulations must be observed. (e.g., VDE/VDI 3512, DIN 19210, VBG, Elex V, etc.).

Measurement accuracy is largely dependent on correct installation of the pressure transmitter and, if applicable, the related measuring tube. The measuring setup should be as free as possible of critical ambient conditions such as major temperature variations, vibration or shock.

Note

If unfavorable ambient conditions cannot be avoided owing to reasons related to building structure, measuring requirements or other reasons, this may influence the measurement quality.

If a pressure sensor with capillary tube is installed, observe also the related data sheets.

Pressure transmitter

The transmitter can be connected directly to the shut-off valve. There is also a mounting bracket for wall or pipe installation (2" pipe) available as an accessory.

The pressure transmitter should be installed so that the display and control unit are accessible during installation and connection, as well as retrofitting.

The transmitter should be installed preferably in a vertical position to avoid subsequent zero shift corrections.

Note

In case of an oblique installation and depending on the measuring range, the fill fluid exerts a hydrostatic pressure on the measuring diaphragm, resulting in a zero shift. The zero point must then be adjusted.

In general, the pressure transmitters can be used in any mounting position. It is installed according to the same guidelines as a manometer

Mounting the transmitter

Testing Impulse piping

To ensure proper proper pipe laying, the following points must be observed:

- Keep the impulse piping as short as possible and avoid sharp bends.
- Route the impulse piping so that no deposits can accumulate. Angles of inclination should not be less than 8 % ascending or descending.
- The impulse piping should be blown through with compressed air or better yet flushed through with the measuring medium before connection.
- Completely bleed the impulse piping if the medium is a fluid.
- Lay the impulse piping so that gas bubbles (when measuring fluids) or condensate (when measuring gases) can flow back into the process line.
- When measuring steam, make sure that hot steam cannot flow back into the process connection (hydraulic seal, e.g., a siphon is filled with water before installation).
- Check the tightness of the connection. or calibration input, and provide space for the housing cover to be removed for electrical wiring and maintenance

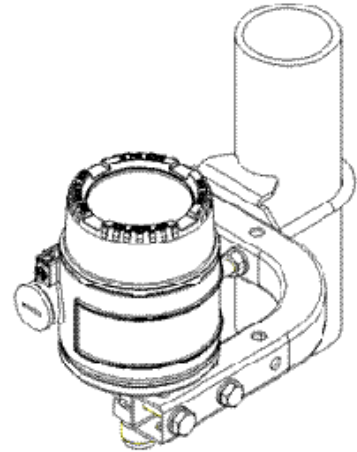

Sealing and screwing in

Connecting pin G ½ B:

For sealing, a flat gasket must be used in accordance with DIN EN 837-1.

NPT threaded connector:

Seal the threads with Teflon or another approved, resistant sealant.

Reference to atmosphere for 364Gx

For technical reasons it is necessary to apply atmospheric pressure to the reference side of the pressure sensor.

For this purpose there is a ventilation aperture at the outside of the sensor which is protected by a PTFE filter.

Make sure that the ventilation opening is not covered (e.g., do not paint over or wet with silicon oil containing fluids etc.) A coating results in measuring errors!

NOTE: In addition, consider the need of a testing or calibration input, and provide space for the housing cover to be removed for electrical wiring and maintenance.

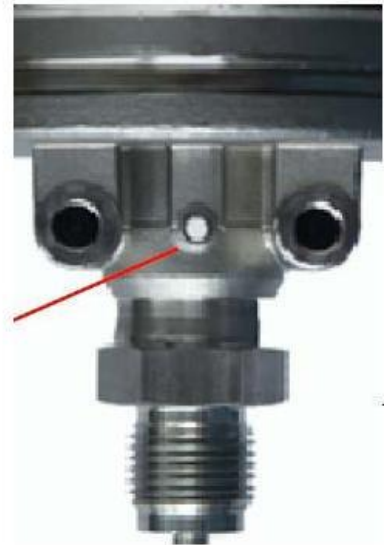

WARNING !

Process leaks may cause harm or result in death. Install and tighten process connectors and all accessories (including manifolds) before applying pressure.

In case of toxic or other dangerous process fluid, take all precautions as recommended in the relevant Material Safety Data Sheet when draining or venting.

Use only a 12 mm (15/32 ") hexagonal spanner to tighten the bracket bolts

Pipe mounting

In this chapter you can find some suggestions for pipe mounting. These suggestions shall not limit alternative solutions that the end user can define himself.

**Horizontal pipe
Vertical bracket
Transmitter on the front**



**Horizontal pipe
Horizontal bracket
Transmitter on up**

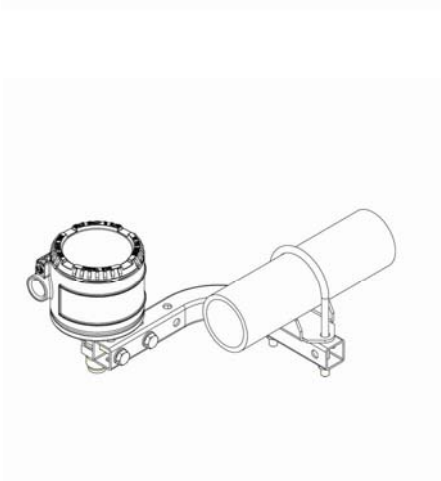

**Vertical pipe
Horizontal bracket
Transmitter on the front**

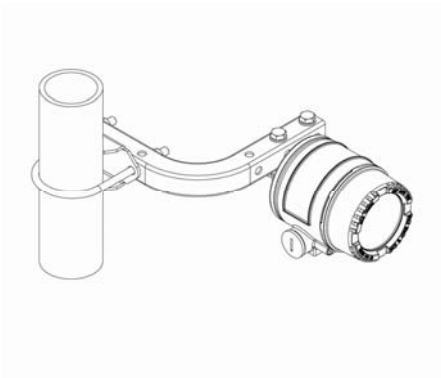

Vertical pipe
Horizontal bracket
Transmitter on up

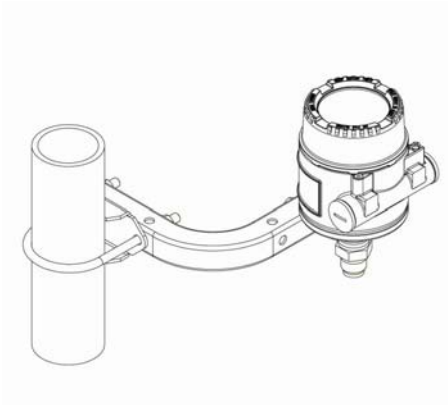

Vertical pipe
Horizontal bracket
Transmitter on the front

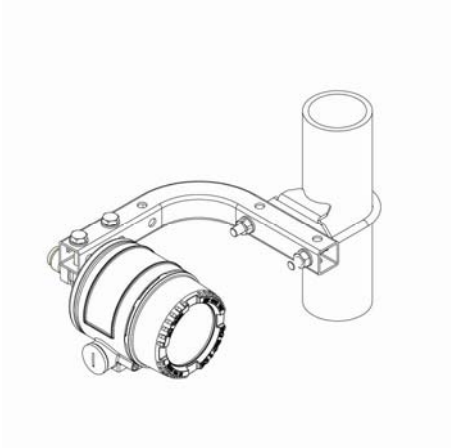

Vertical pipe
Horizontal bracket
Transmitter on up

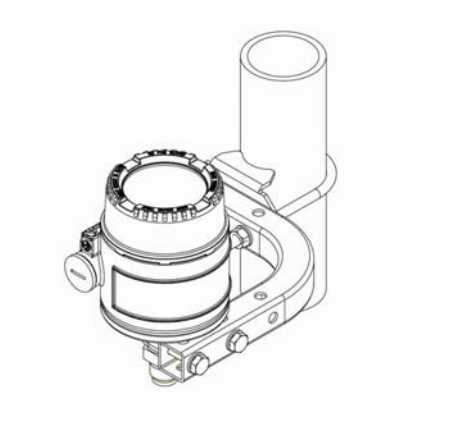

Horizontal pipe
Vertical bracket
Transmitter on up

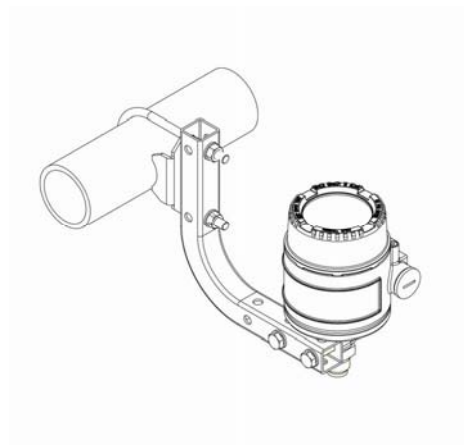

Horizontal pipe
Vertical bracket
Transmitter on side (parallel)



2in Pipe mounting instruction

1. Fix the bracket ① in the defined position on the pipe using the tool ② and the adapter ③ to guarantee the best mechanical performances of the assembly
 2. Tight the nuts ④ with the washers ⑤ below them in order to fix the bracket (the torque value shall be 10 Nm - 12 Nm)
- Fix the Pressure transmitter using the two screws ⑥ in the package; (the torque value shall be 1 Nm \pm 0.2 Nm)

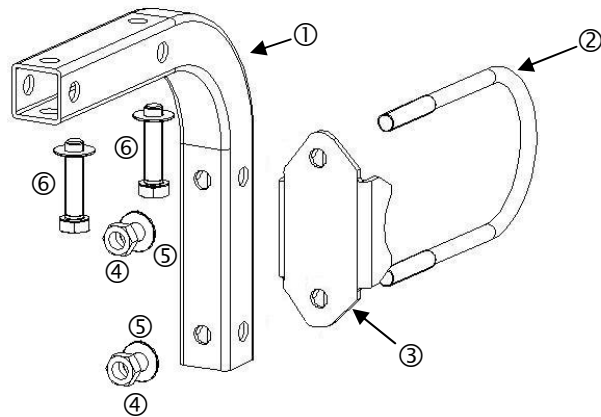

Wall mounting

In this chapter you can find suggestions for wall mounting. These suggestions shall not limit alternative solutions that the end user can define himself.

Wall mounting Vertical bracket

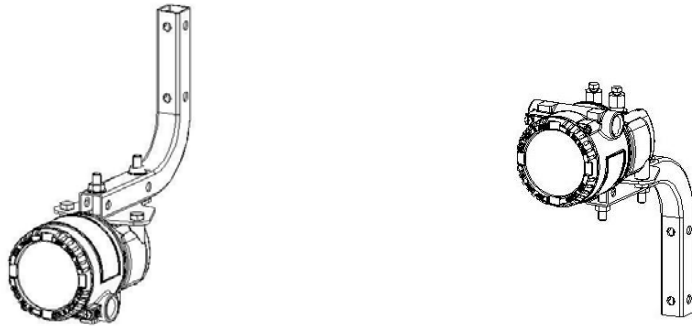

Wall mounting instruction

1. Fix the bracket ① at the wall in the final position
2. Connect the instrument interface using the two long screws ② and bolts ③ in the package (the torque value shall be between 10 Nm and 12 Nm)
3. Fix the Pressure transmitter ④ using the two short screws ⑤ in the package (the torque value shall be $1 \text{ Nm} \pm 0.2 \text{ Nm}$)

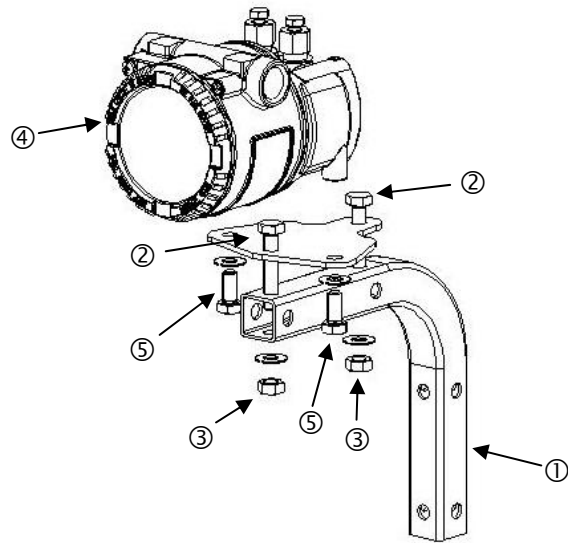

The use of the washers as indicated in the picture is strongly recommended

Digital LCD Integral Display positioning

In case the optional integral display meter is installed, it is possible to mount the display in four different positions rotated clockwise or counter-clockwise with 90° steps.

This is possible by using one of the four connections located on the back of the display at a 90° angle each from the other.

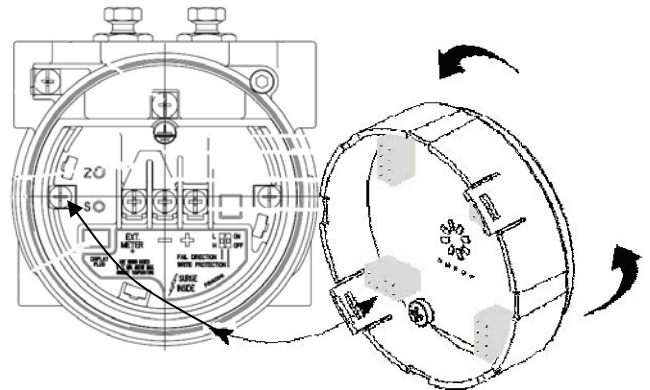

Wiring

HART hand-held communicator can be connected at any wiring termination point in the loop, the minimum resistance provided must be 250 ohm. If this is less than 250 ohm, additional resistance should be added to allow communication.

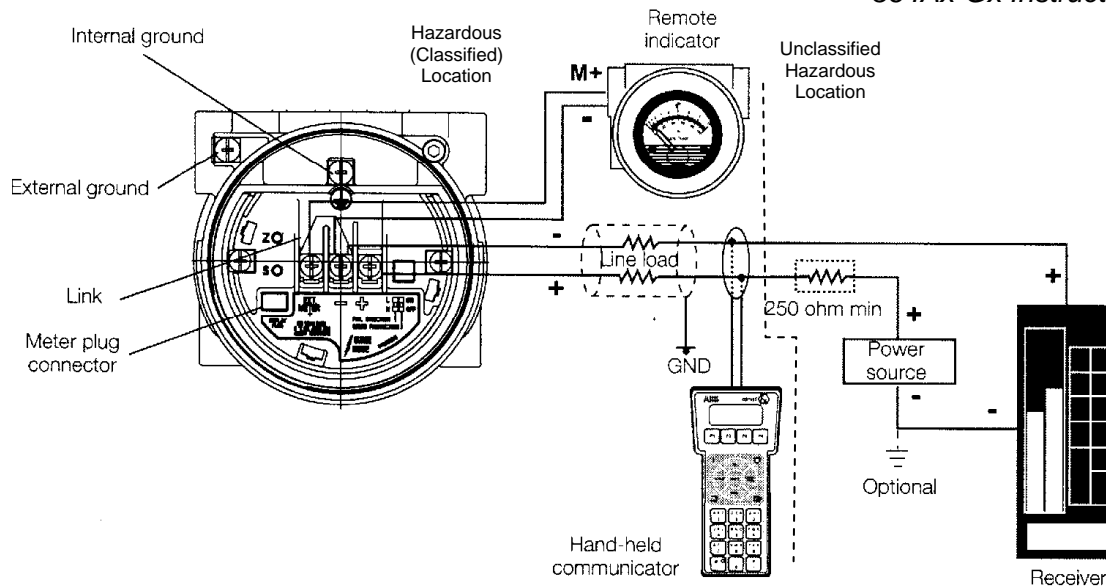

Wiring requirements

For signal / power connection use twisted, stranded pairs of wiring no 18 to 22 AWG / 0.8 to 0.35 mm² Ø up to 5,000 feet (1 500 meters). Longer loops require larger wire.

If a shielded wire is used the shield should be grounded only at one end, not both ends. In case of wiring at transmitter end, use the terminal located inside the housing marked with the symbol 

Protective Earthing

Wire this ground connection marked with the symbol  to a suitable earth ground.

For a transmitter measuring loop an earth ground should maintain a resistance of 5 ohms or less.

Use a heavy conductor, at least 15 AWG / 1,6 mm² Ø



WARNING !

A protective grounding connection is absolutely necessary to ensure personnel protection, to protect against surge and to prevent explosions in potentially explosive atmosphere.



WARNING !

The surge protection is always present and if the transmitter is installed in a Hazardous classified location, it must be powered from a voltage source isolated from mains (galvanic separation). Furthermore the potential equalization for the entire powering cable must be guaranteed since the intrinsic safety circuit of the transmitter is grounded.

Electrical connection



WARNING !

Do NOT make any electrical connections unless the electrical code designation stamped on the transmitter data plate agrees with the classification of the area in which the transmitter is to be installed. Failure to comply with this warning can result in fire or explosion.

The relevant guidelines must be observed during the electrical installation!

The electrical connection may only be performed by authorized specialists according to the electrical plans. Comply with electrical connection information in the manual. Otherwise, the electrical protection can be affected.

The 4 to 20 mA output signal and the dc power supply to the transmitter are carried from the same pairs of wires. The supply voltage at the transmitter terminals must be between the limits of 10.5 and 42V dc.

For intrinsically safe approval Ex ia supply must not exceed 30 Vdc. In some countries the maximum power supply voltage is limited to a lower value.



WARNING !

Electrical shock can result in death or serious injury. Avoid contact with the leads and terminals. High voltage that may be present on leads can cause electrical shock.

Follow these steps to wire the transmitter:

1. Remove the red temporary plastic plug from one of the two electrical connection ports located at both sides on the top part of the transmitter housing
2. These connection ports have a ½ inch internal NPT or CM20 x 1.5 mm threads. Various adaptors and bushings can be fitted to these threads to comply with plant wiring (conduit) standards.
3. Remove the housing cover.



WARNING !

In an Explosion-Proof/Flame-Proof installation, do not remove the transmitter covers when power is applied to the unit. Remove the power supply and continue the operation

4. Run wires through the open port
5. Connect the positive lead to the + terminal, and the negative lead to the - terminal



WARNING !

Note: Do not connect the power across the test terminals. Power could damage the diode in the test connection.

Plug and seal the electrical ports. Make sure that when the installation has been completed, the electrical ports are properly sealed against entry of water and corrosive vapors and gases.



WARNING !

Cables, cable gland and unused port plug must be in accordance with the intended type of protection (e.g. intrinsically safe, explosion proof, etc.) and degree of protection (e.g. IP6x or NEMA 4x). In particular, for explosion proof installation, plug the unused opening with a plug certified for explosion containment.

6. If applicable, install wiring with a drip loop. Arrange the drip loop so that the bottom is lower than the conduit connections and the transmitter housing.
7. Place the housing cover, screw it to fit O-ring into the housing and then continue to hand tighten until the cover touch the housing metal-to-metal. In Ex d (Explosion Proof) installation, lock the cover rotation by turning the set nut (use the 3 mm Allen key supplied with the instrument).
8. Replace the temporary red plastic plug on the second electrical connection port located in the upper part of the transmitter housing with the appropriate plug depending on the certification requirement or degree of protection (e.g. IP6x or NEMA 4x)

For further information find the relevant instruction manuals searching for the keyword "IM/*36*" on www.abb.com or from local ABB representatives.

Remote Meter wiring

Before starting the Remote Meter wiring be sure that the transmitter has been wired according to the previous paragraph instructions.



WARNING !

Electrical shock can result in death or serious injury. Avoid contact with the leads and terminals. High voltage that may be present on leads can cause electrical shock.

Follow these steps to wire the Remote Meter:

1. Remove the housing cover.



WARNING !

In an Explosion-Proof/Flame-Proof installation, do not remove the transmitter covers when power is applied to the unit. Remove the power supply first and continue the operation

2. Run wiring through the same port of the electrical connection or the other port removing the plug.
3. Connect the positive lead of the remote meter to the "EXT METER +" terminal, and the negative lead to the "-" terminal.

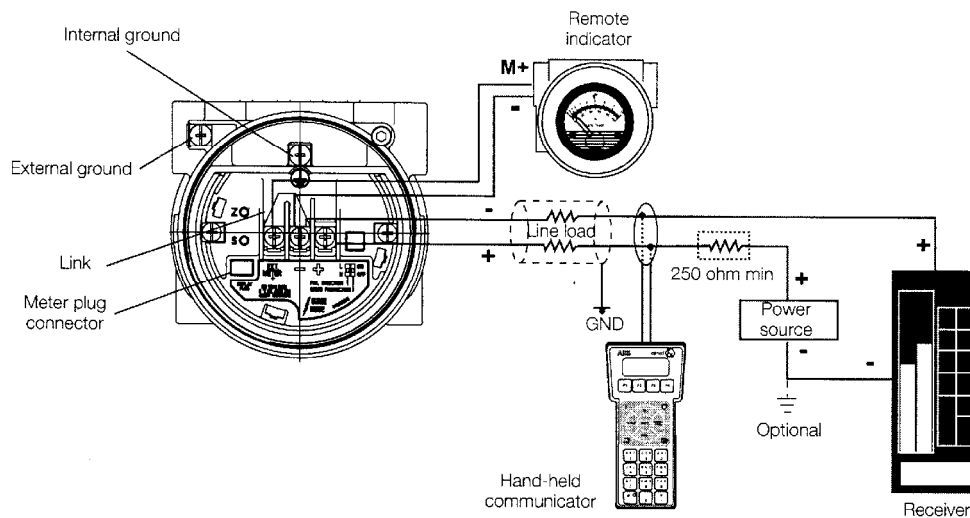

4. Plug and seal the ports. Make sure that when the installation has been completed, the ports are properly sealed against entry of water and corrosive vapors and gases.



WARNING !

Cables, cable gland and unused port plug must be in accordance with the intended type of protection (e.g. intrinsically safe, explosion proof, etc.) and degree of protection (e.g. IP6x or NEMA 4x). In particular, for explosion proof installation, plug the unused opening with a plug certified for explosion containment.

5. Install and tighten the housing cover, turn it to seat O-ring into the housing and then continue to hand tighten until the cover contacts the housing metal-to-metal. In Ex-d (Explosion Proof) installation, lock the cover rotation by turning the set nut (use the 3 mm Allen key supplied with the instrument).

For further information find the relevant instruction manuals searching for the keyword "IM/*36*" on www.abb.com or from local ABB representatives.

Check the installation

Before applying power and pressure, perform the following checks.

√	Check
	Installation environment conforms to the transmitter specification for ambient conditions
	The transmitter is mounted securely
	The transmitter is properly grounded
	The input power voltage matches the transmitter nominal input voltage
	The plugs/vents and process connections are tightened as specified
	The proper electrical adapter are installed and are tightened as specified
	The red plug on the electrical input not used is replaced with a proper plug
	The cover is tightened up to metal to metal contact with the housing
	All the requirements are satisfied if the transmitter is working in hazardous area

Apply power

The transmitter will start up automatically at the power up.

If, when using "intrinsically safe" transmitters, an ammeter is connected to the output circuit or a modem is connected in parallel when an explosion hazard is present, the sums of the capacitance and inductance of all circuits, including transmitter (see EC type examination certificate) must be equal to or smaller than the permissible capacitance and inductance of the intrinsically safe signal circuit (see EC type examination certificate for the power supply). Only passive or explosion-protected devices or indicators may be connected.

If the output signal stabilizes only slowly, a large damping time constant was likely set in the transmitter.

Start up

The transmitter has default parameter settings that are sufficient for many situations and start up of the instrument. However, review the configuration chapter for the default parameter settings values and the parameter changes procedures.

Configuration

Default configuration

The data default configuration at the product delivery is the following:

Damping:	1 second
Units:	kPa
LRV:	0 kPa
URV:	equal to URL
Transfer function:	linear
Hardware setting:	Write protect mode in OFF, Failsafe direction High
Low saturation current:	3.8 mA
High saturation current:	20.5 mA
Low fail current:	3.7 mA
High fail current:	22 mA
LCD Display:	Set to display the PV value.

Easy Setup

To facilitate commissioning the 364 Display has the capability to run a sequence of predefined setup steps with the main configuration settings.

When you start the Easy Setup you must continue up to the end to exit.

To start the Easy Setup:

Navigate the Digital LCD Integral Display menu, select **Easy Setup**.

☞ Digital LCD Integral Display Keys sequence to start the Easy Setup: 1

Define the language

If the desired language is different from the default one select **Edit** then choose the desired language (see the following table) scrolling with the up and down keys and confirming with **OK**. Select **Next** to continue.

English	Spanish	Italian
German	French	

Define the Engineering Unit

If the desired Engineering Unit is different from the indicated, select **Edit** then choose the desired unit (see the following table) scrolling up and down keys and confirm with **OK**. Select **Next** to continue.

mbar	millibar	mmH2O°C	millimeter of water at 4 degrees Celsius
g/cm²	grams per square centimeter	inH2O°F	inches of water at 68 degrees Fahrenheit (20°C)
Kg/cm²	kilo grams per square centimeter	inHg°C	inches of mercury at 0 degrees Celsius
Pa	pascal	ftH2O°F	feet of water at 68 degrees Fahrenheit (20°C)
kPa	kilopascal	mmH2O°F	millimeter of water at 68 degrees Fahrenheit (20°C)
torr	torr	mmHg°C	millimeter of mercury at 0 degrees Celsius
atm	atmosphere	psi	Pounds per square inch
MPa	Megapascal	bar	Bars
inH2O°C	inches of water at 4 degrees Celsius		

Define the Lower Range value (LRV)

If the desired LRV is different from the default one select **Edit**, then choose the desired value for the digit in reverse color with the up and down keys and confirm with **Next**. Repeat the operation for the seven digits and confirm with **OK**. Select **Next** to continue.

Note: the minimum and the maximum allowed values are indicated on the display.

Define the Upper Range Value (URV)

If the desired URV is different from the indicated select **Edit**, scroll the desired value for the digit in reverse color with the up and down keys and confirm with **Next**. Repeat the operation for the seven digits and confirm with **OK**. Select **Next** to continue.

Note: the minimum and the maximum allowed values are indicated on the display.

Run the Zero Scaling

In case a Zero Scaling is required apply the pressure for the Zero and select **OK**. Wait for the auto-set end (the bargraph will indicate the working progress). Select **Next** to continue.

Define the Damping

If the desired Damping is different from the indicated value change it with the up and down keys and confirm with **OK**.

HART Configuration

Basic Configuration Functions

This chapter describes some additional functions provided by the 364xS models which are unique to the 2600T pressure transmitter family.

Set the Damping

When damping different from default value is needed, it is possible to set its value in seconds following one of the methods described in the next paragraphs.

Set the Damping configuration by Digital LCD Integral Display

Navigate the Digital LCD Integral Display menu, select **Device Config** > *Damping*, set the desired value with the up and down keys and confirm with **OK**.

☞ Digital LCD Integral Display Keys sequence to set the Damping: 2 – 3

Set the Damping configuration by CoMeter

Damping configuration by CoMeter is available with the 695 Field Indicator. Please refer to the device manual for the appropriate operations.

Set the Damping configuration by HHT

Damping configuration by Hand Held Terminal is available. Please refer to the device manual for the appropriate operations.

Set the Damping configuration by PC

Damping configuration by PC is available using dedicated Software. ABB can provide the references and the Software. Please refer to the Software instructions for the appropriate operations.

Set the Units

To monitor the process using the appropriate units follow one of the methods described in the next paragraphs.

Set the Units by Digital LCD Integral Display

To change the unit in the Digital LCD Integral Display

Navigate the Digital LCD Integral Display menu, select **Display** > *Display Settings* > *Display Eng. Unit*, and the possible Engineering variables will be available. To select the type, push **Edit** and scroll with a up and down keys; confirm with **OK**.

Pressure

Temperature

Mass & Volume

Level

Other

Custom Unit

The in-use unit for the type will be available. To modify select **Edit** then scroll the desired unit (see the following tables) with the up and down keys and confirm with **OK**.

Units for Pressure variable

<i>mbar</i>	millibar	<i>mmH2O°C</i>	millimeter of water at 4 degrees Celsius
<i>g/cm²</i>	grams per square centimeter	<i>inH2O°F</i>	inches of water at 68 degrees Fahrenheit (20°C)
<i>Kg/cm²</i>	kilo grams per square centimeter	<i>inHg°C</i>	inches of mercury at 0 degrees Celsius
<i>Pa</i>	pascal	<i>ftH2O°F</i>	feet of water at 68 degrees Fahrenheit (20°C)
<i>kPa</i>	kilopascal	<i>mmH2O°F</i>	millimeter of water at 68 degrees Fahrenheit (20°C)
<i>torr</i>	torr	<i>mmHg°C</i>	millimeter of mercury at 0 degrees Celsius
<i>atm</i>	atmosphere	<i>psi</i>	pounds per square inch
<i>MPa</i>	Megapascal	<i>bar</i>	bars
<i>inH2O°C</i>	inches of water at 4 degrees Celsius		

Units for Temperature variable

°C	degree Celsius
°F	degree Fahrenheit
°R	degree Rankine
K	Kelvin

Units for Mass and Volume variable

L	liter	Nm ³	Normal cubic meter
hl	hectoliter	NL	Normal liter
in ³	cubic inch	g	gram
ft ³	cubic feet	kg	kilogram
yd ³	cubic yard	t	ton
gallon	US gallon	lb	pound
ImpGal	Imperial gallon	STon	short ton
bushel	bushel	LTon	long ton
bbl	barrel	oz	ounce
bbl liq	barrel liquid	m ³	cubic meter
SCF	standard cubic feet		

Units for Level

m	meter	ft	feet
cm	centimeter	in	inch
mm	millimeter		

Other Units

N	Newton	mV	millivolts
mA	milliamperes	%	percentage
V	volts		

☞ Digital LCD Integral Display Keys sequence to change the unit on the Display: 3 – 7 – 1

To change the PV unit in the transmitter:

Navigate the Digital LCD Integral Display menu, select **Device Config** > *Rerange* > *Rerange no pressure* > *Engineering Unit*, and the used unit will be available. To modify select *Edit* then scroll the desired unit (see the following table) with the up and down keys and confirm with **OK**.

mbar	millibar	mmH2O°C	millimeter of water at 4 degrees Celsius
g/cm ²	grams per square centimeter	inH2O°F	inches of water at 68 degrees Fahrenheit (20°C)
Kg/cm ²	kilo grams per square centimeter	inHg°C	inches of mercury at 0 degrees Celsius
Pa	pascal	ftH2O°F	feet of water at 68 degrees Fahrenheit (20°C)
kPa	kilopascal	mmH2O°F	millimeter of water at 68 degrees Fahrenheit (20°C)
torr	torr	mmHg°C	millimeter of mercury at 0 degrees Celsius
atm	atmosphere	psi	pounds per square inch
MPa	Megapascal	bar	bars
inH2O°C	inches of water at 4 degrees Celsius		

☞ Digital LCD Integral Display Keys sequence to change the unit in the Transmitter: 2 – 1 – 2 – 1 – Edit

Set the Unit by CoMeter/ProMeter

Unit configuration by CoMeter/ProMeter is available with the 695 Field Indicator. Please refer to the device manual for the appropriate operations.

Set the Unit configuration by HHT

Unit configuration by Hand Held Terminal is available. Please refer to the device manual for the appropriate operations.

Set the Unit configuration by PC

Unit configuration by PC is available using dedicated Software. ABB can provide the references and the Software. Please refer to the Software instructions for the appropriate operations.

Set the LRV

When a LRV different from the selected is needed it is possible to change it following one of the methods described in the next paragraphs.

Set the LRV by Local Keys

When the applied pressure is stable push the Zero local adjustment key (Z) located on the terminal block and release. After this operation the reading shall move to 4 mA. If no changes occur repeat the operation.

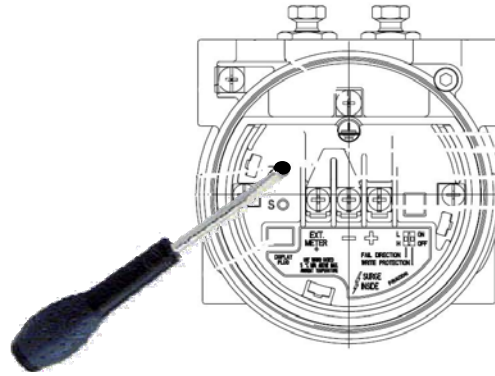

Set the LRV by Digital LCD Integral Display

To set the LRV reading of the Digital LCD Integral Display (the engineering units have to be selected):

Navigate the Digital LCD Integral Display menu, select **Display** > **Display settings** > **Display LRV (0%)**, and the Zero values will be available. Select the desired value and confirm.

☞ Digital LCD Integral Display Keys sequence to set the Display LRV : 3 – 7 – 2 - Edit

To set the Transmitter LRV without reference pressure:

Navigate the Digital LCD Integral Display menu, select **Device Config** > **Rerange** > **Rerange no pressure** > **Set LRV**, and the LRV values will be available. To modify select **Edit** then scroll the desired value for the digit in reverse color with the up and down keys and confirm with **Next**. Repeat the operation for the seven digits and confirm with **OK**.

Note: the minimum and the maximum values to select are indicated on the display.

☞ Digital LCD Integral Display Keys sequence to set the LRV without pressure: 2 – 1 – 2 – 2 – Edit

To set the Transmitter LRV with reference pressure:

Set the transmitter applied pressure as for Lower Range value (0%). Navigate the Digital LCD Integral Display menu, select **Device Config** > **Rerange** > **Rerange with pressure** > **Set LRV (0%)**. Select **OK** to start the autoadjust.

☞ Digital LCD Integral Display Keys sequence to set the LRV with pressure: 2 – 1 – 1 – 1 – OK

Set the LRV by CoMeter

LRV configuration by CoMeter is available with the 695 Field Indicator. Please refer to the device manual for the appropriate operations.

Set the LRV by HHT

LRV configuration by Hand Held Terminal is available. Please refer to the device manual for the appropriate operations.

Set the LRV by PC

LRV configuration by PC is available using dedicated Software. ABB can provide the references and the Software. Please refer to the Software instructions for the appropriate operations.

Set the URV

When a URV different from the selected is needed it is possible to change it following one of the methods described in the next paragraphs.

Set the URV by Local Keys

Set the transmitter applied pressure as for Upper Range Value. When the applied pressure is stable push the Span local adjustment key (S) located on the terminal block and release. After this operation the reading shall move to 20 mA. If no changes occur repeat the operation.

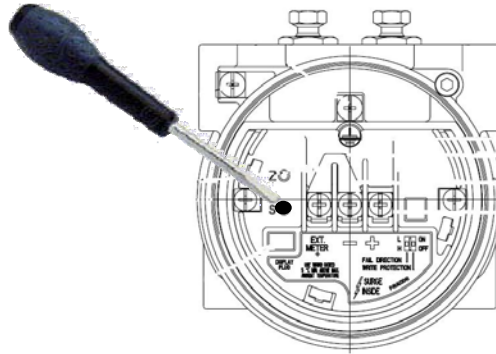

Set the URV by Digital LCD Integral Display

To set the URV reading of the Digital LCD Integral Display (the engineering units have to be selected):

Navigate the Digital LCD Integral Display menu, select **Display** > **Display settings** > **Display URV (100%)**, and the Span values may be available. Select the desired value and confirm.

☞ Digital LCD Integral Display Keys sequence to set the Display URV : 3 – 7 – 3 - Edit

To set the Transmitter URV without reference pressure:

Navigate the Digital LCD Integral Display menu, select **Device Config** > **Rerange** > **Rerange no pressure** > **Set URV**, and the URV values may be available. Select the desired value and confirm.

☞ Digital LCD Integral Display Keys sequence to set the URV without pressure: 2 – 1 – 2 – 3 – Edit

To set the Transmitter URV with reference pressure:

Set the transmitter applied pressure as for Upper Range value (100%). Navigate the Digital LCD Integral Display menu, select **Device Config** > **Rerange** > **Rerange with pressure** > **Set URV (100%)**. Select **OK** to start the autoadjust.

☞ Digital LCD Integral Display Keys sequence to set the URV with pressure: 2 – 1 – 1 – 2 – OK

Set the URV by CoMeter

URV configuration by CoMeter is available with the 695 Field Indicator. Please refer to the device manual for the appropriate operations.

Set the URV by HHT

URV configuration by Hand Held Terminal is available. Please refer to the device manual for the appropriate operations.

Set the URV by PC

URV configuration by PC is available using dedicated Software. ABB can provide the references and the Software. Please refer to the Software instructions for the appropriated operations.

Special functions

The transmitter has some functions to support the user in case of applications that require advance output configuration.

Transfer functions

The 2600T Pressure Transmitter Series provides a selection of output functions, as follows:

Linear	for differential, gauge and absolute pressure or level measurements
Sq. Root (x3)	for open channel flow measurements using rectangular or trapezoidal weir
Sq. Root (x5)	for open channel flow measurements using V-notch (triangular) weir.
Polynomial	for input linearization using a 5th-order polynomial function for input linearization using 2 polynomial functions of 2nd order
Costant current	for loop or associated equipment test.

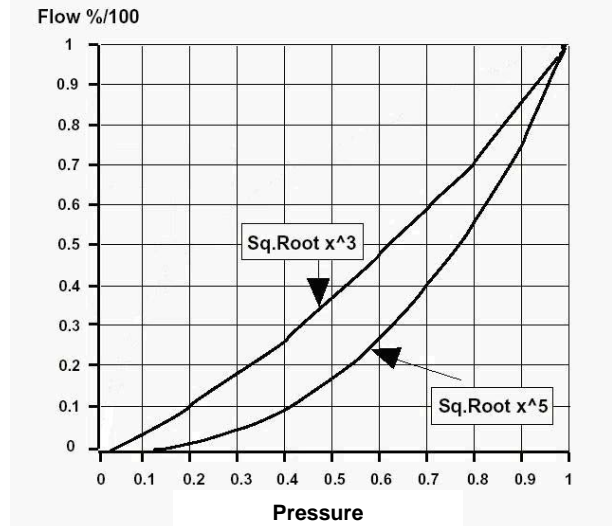

Note: x and output are in the range 0 to 1 (0% to 100%)

These output functions can be activated using a Configuration Tool (CoMeter, Digital LCD Integral Display, Hand Held Communicator and PC).

The transfer function can be applied to the analog signal 4 to 20 mA or to the indication (in engineering units) on the CoMeter with the 695 Field Indicator and/or to the Digital LCD Integral Display.

Transfer functions description

Linear

Using this function, the relationship between the input (measured value), expressed in % of the calibrated span and the output is linear (i.e.: at 0% input, corresponds 0% output - 4mA - at 50% input corresponds 50% output - 12mA - and at 100% input corresponds 100% output - 20mA).

Polynomial

The polynomial function, applied to the transmitter input (x) expressed in percentage of the calibrated span, has the following form:

$$\text{Output} = A_0 + A_1x + A_2x^2 + A_3x^3 + A_4x^4 + A_5x^5$$

where: x and Output should be normalized in the range 0 to 1 for calculation purpose, with following Output meaning: Output = 0 means Analog out 4 mA; Output = 1 means Analog out 20 mA

This function can be used for linearization purpose: the user can plot the characteristic curve of the input and find, using a mathematical method, the parameters of the polynomial that better approximate the plotted curve. Check, after the calculation, if the maximum error is compatible with the application.

Two Polynomial functions of 2nd order

The Analog Output transfer function can also be defined as a two polynomial function. Both polynomials are of 2nd order. So two different polynomial functions are used:

$$\begin{aligned} \text{Output} &= A_0 + A_1 x + A_2 x^2 & \text{if } x \leq k \\ \text{Output} &= B_0 + B_1 x + B_2 x^2 & \text{if } x > k \end{aligned}$$

Ax and Bx terms of the polynomials have to be calculated according to the shape of the vessel. A PC based software tool is available for polynomial coefficients definition.

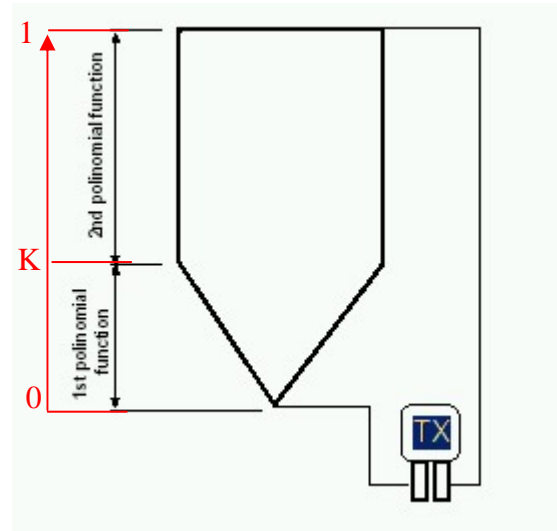

Set the Transfer function on the transmitter

Set the Transfer function on the transmitter by Digital LCD Integral Display

Navigate the Digital LCD Integral Display menu, select **Device Config** > *Transfer Function* > *Type*, and the Transfer Function in use will be available. To modify select *Edit* then scroll the desired Transfer Function (see the following table) with the up and down keys and confirm with *OK*.

<i>Linear</i>	Output = x
<i>3/2</i>	Output = x ^{3/2}
<i>5/2</i>	Output = x ^{5/2}
<i>Polynomial</i>	Output = A ₀ + A ₁ x + A ₂ x ² + A ₃ x ³ + A ₄ x ⁴ + A ₅ x ⁵
<i>Double Poly</i>	$\begin{cases} \text{Output} = B_0 + B_1 x + B_2 x^2 & \text{if } x \leq k \\ \text{Output} = C_0 + C_1 x + C_2 x^2 & \text{if } x > k \end{cases}$

☞ Digital LCD Integral Display Keys sequence to set the Transfer Function: 2 – 6 – 1 – Edit

In case one of the polynomial transfer function has been selected

The existing polynomial coefficients in the transmitter will be used. The coefficients can be set or modified only by HHT and PC.

Set the Transfer function on the transmitter by CoMeter

The Transfer function setting by CoMeter is available with the 695 Field Indicator. Please refer to the device manual for the appropriate operations.

Set the Transfer function on the transmitter by HHT

The Transfer function setting by Hand Held Terminal is available. Please refer to the device manual for the appropriate operations.

Set the Transfer function on the transmitter by PC

The Transfer function setting by PC is available using dedicated Software. ABB can provide the references and the Software. Please refer to the Software instructions for the appropriate operations.

Set the Transfer function on the Meters

The Transfer function on the Meters works only on the meters reading and not on the transmitter output.

Set the Transfer function on the Digital LCD Integral Display

On the Digital LCD Integral Display only the transfer function can be selected. The existing parameter or polynomial coefficients in the transmitter will be used. The coefficients can be set or modified only by HHT and PC.

Navigate the Digital LCD Integral Display menu, select **Display** > *Display Settings* > *Display Transfer Function*, and the Transfer functions will be available.

Select the desired value and confirm.

☞ Digital LCD Integral Display Keys sequence to set the Transfer Function on the Display: 3 – 7 – 4 – Edit

Set the Transfer function on the Digital LCD Integral Display by HHT

The Digital LCD Integral Display Transfer function setting by Hand Held Terminal is available. Please refer to the device manual for the right operations.

Set the Transfer function on the Digital LCD Integral Display by PC

The Digital LCD Integral Display Transfer function setting by PC is available using dedicated Software. ABB can provide the references and the Software. Please refer to the Software instructions for the right operations.

Signal simulation (fixed output current)

During the start up or for diagnostic purposes, it is useful to have the possibility to generate some reference signal to be sent to the receiver (Controller, DCS, recorder, PLC, etc.). This is possible directly by means of the transmitter, without disconnect its electrical connection and without a 4-20 mA generator or a pressure generator.

Fixed output current by Digital LCD Integral Display

To set 4 mA fixed output current

Navigate the Digital LCD Integral Display menu, select **Diagnostics** > *Loop Test* > *Set 4 mA*. Confirm.

☞ Digital LCD Integral Display Keys sequence to set 4 mA fixed output current: 7 – 2 – 1

To set 20 mA fixed output current

Navigate the Digital LCD Integral Display menu, select **Diagnostics** > *Loop Test* > *Set 20 mA* for 20 mA fixed output current. Confirm.

☞ Digital LCD Integral Display Keys sequence to set 20 mA fixed output current: 7 – 2 – 2

To set any fixed output current

Navigate the Digital LCD Integral Display menu, select **Diagnostics** > *Loop Test* > *Set Custom Value* and the fixed output current values will be available. Select the desired value and confirm.

☞ Digital LCD Integral Display Keys sequence to set any fixed output current: 7 – 2 – 3

Fixed output current by CoMeter

Set of the Fixed output current by CoMeter is available with the 695 Field Indicator. Please refer to the device manual for the appropriate operations.

Fixed output current by HHT

Set of the Fixed output current by Hand Held Terminal is available. Please refer to the device manual for the appropriate operations.

Fixed output current by PC

Set of the Fixed output current by PC is available using dedicated Software. ABB can provide the references and the Software. Please refer to the Software instructions for the appropriate operations.

Hardware settings

Write protect mode

Changes can be prevented to the transmitter configuration data with the write protection electronics dip switch 2. If the transmitter write protection is activated the transmitter will not accept any writes to its memory. Configuration changes, such as trim and reranging cannot take place. In case the Digital LCD Integral Display is installed (no access to switch), the Write protect mode can also be set by HART command using the HHT and the PC. Please refer to the device manual and Software instruction for the right operation.

Position the right dip switch in ON to prevent accidental or deliberate change of configuration data.



ON
OFF

Position the right dip switch in OFF to change the configuration data. If data configuration is not allowed check the Software Write lock using the HHT or PC.



ON
OFF

Change the failsafe direction

The transmitter alarm direction is set by repositioning the electronics dip switch 1. The output value is in accordance with NE43 NAMUR recommendations.

Check the Software failsafe direction is set to Hardware before the operation. Position the left dip switch in L for fail low (i.e. output current: 3.7 mA)



L
H

Check the Software failsafe direction is set to Hardware before the operation. Position the left dip switch in H for fail high (i.e. output current: 22 mA)



L
H

Software settings

Write protect mode

Changes can be prevented to the transmitter configuration data with the write protection electronics dip switch 2. If the transmitter write protection is activated the transmitter will not accept any writes to its memory. Configuration changes, such as trim and reranging cannot take place. In case the Digital LCD Integral Display is installed the Write protect mode can also be set by HART command using the HHT and the PC. Please refer to the device manual and Software instruction for the right operation.

Change the failsafe direction

The transmitter alarm direction is set selecting the Failure Mode in the transmitter software. The output value is in accordance with NE43 NAMUR recommendations.

Navigate the Digital LCD Integral Display menu, select **Device config** > **Output on alarm** > **Failure Mode** and the Failure Mode in use will be visible. To modify select **Edit** then scroll the desired Failure Mode (see the following table) with the up and down keys and confirm with **OK**.

As per Dip-Switch
Fail High

to give the Failure Mode control at the Hardware setting
to set the Failure Mode in high current condition (the value can be set by the user following the appropriate procedure of this manual)

Fail Low

to set the Failure Mode in low current condition (the value can be set by the user following the appropriate procedure of this manual)

☞ Digital LCD Integral Display Keys sequence to change the failsafe direction: 2 – 4 – 1 - Edit

Set the Current Output limits

When the Current Output limits on alarm and saturation different from the selected is needed it is possible to change it following one of the methods described in the next paragraphs.

Set the Current Output limits on the Digital LCD Integral Display

To set High Saturation current

Navigate the Digital LCD Integral Display menu, select **Device config** > *Output on alarm* > *Set Fail Current* > *High Saturation* > *Edit*, and the value change will be possible. Select the desired value and confirm.

☞ Digital LCD Integral Display Keys sequence to set the High saturation current: 2 – 4 – 2 – 1 – Edit

To set Low Saturation current

Navigate the Digital LCD Integral Display menu, select **Device config** > *Output on alarm* > *Set Fail Current* > *Low Saturation* > *Edit*, and the value change will be possible. Select the desired value and confirm.

☞ Digital LCD Integral Display Keys sequence to set the Low saturation current: 2 – 4 – 2 – 2 – Edit

To set Fail High current

Navigate the Digital LCD Integral Display menu, select **Device config** > *Output on alarm* > *Set Fail Current* > *Fail High* > *Edit*, and the value change will be possible. Select the desired value and confirm.

☞ Digital LCD Integral Display Keys sequence to set the Fail High current: 2 – 4 – 2 – 3 - Edit

To set Fail Low current

Navigate the Digital LCD Integral Display menu, select **Device config** > *Output on alarm* > *Set Fail Current* > *Fail Low* > *Edit*, and the value change will be possible. Select the desired value and confirm.

☞ Digital LCD Integral Display Keys sequence to set the Fail Low current: 2 – 4 – 2 – 4 - Edit

Set the Current Output limits by HHT

The setting of the Current Output limits by Hand Held Terminal is available. Please refer to the device manual for the right operations.

Set the Current Output limits by PC

The setting of the Current Output limits by PC is available using dedicated Software. ABB can provide the references and the Software. Please refer to the Software instructions for the right operations.

Operation

Digital LCD Integral Display

The L1 " Digital LCD Integral Display" is connected to the electronics. The in-built key-pad allows both display and transmitter configuration.

In addition, diagnostic information is provided. The highest priority message will be displayed first followed by the next message in order of priority.



Here is a list of self explanatory errors and warning messages:

"Electronic Fail",
 "Sensor Elec. Fail",
 "Sensor Fail",
 "DAC Out of Range",
 "Sensor Invalid",
 "PV out of Limit",
 "Sensor T Out Limit",
 "Electr. T Out Limit",
 "Current Out Satur",
 "Current Out Fixed",
 "Config. Error",
 "Tot. Config Error",
 "Overrange",
 "Consistency Check"

For additional details see the "Transmitter Diagnostics" section of this manual.

Navigate the Digital LCD Integral Display

The Digital LCD Integral Display offers you an extensive range of functions, which are grouped into menus:

- to **access** the menu, press the button below the display indication  (the bottom right icons on the Display).
- to **select** the menu or submenu press the key close to the "Select" display indication (bottom right position on the Display)
- to **exit** the menu or submenu press the key close to the "Exit" display indication (bottom left position on the Display)
- to come **back** one step in the menu or submenu press the key close to the "Back" display indication.
- to **scroll** through the menu (up and down in the list on the display) or submenu use two keys in the middle

Digital LCD Integral Display list of menu and submenu functions

The Digital LCD Integral Display menu has been designed to offer self-diagnostics when used by a skilled operator.

Note

The Main Menu, the Sub Menu, the Sub Sub Menu and the Utility view are also indicated on the display with a number. The menu navigation can be described also as a sequence of the corresponding numbers that is called "Digital LCD Integral Display Keys sequence"

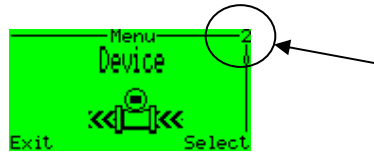

In any case the following table better details the available functions. The instructions of this manual further define the Digital LCD Integral Display menu sequence to run an operation.

Display indication	Description	Level	Type
Easy Setup	<i>This function helps the end user to run the instrument basic configuration</i>	Main Menu	
Language	<i>Set the display language</i>	Utility	Enumerated
Pressure Polarity	<i>Set the pressure transmitter High pressure side</i>	Utility	Enumerated
Engineering Unit	<i>Set the Engineering Variable unit</i>	Utility	Enumerated
Set LRV	<i>Set the Lower Range Value</i>	Utility	Numerical
Set URV	<i>Set the Upper Range value</i>	Utility	Numerical
Transfer Function Type	<i>Set the transmitter output transfer function</i>	Utility	Enumerated
Auto-Set Zero Scaling	<i>Set the Primary Variable at Zero</i>	Utility	Auto Adjust
Damping	<i>Set the damping value</i>	Utility	Manual Adjust
Device Config	<i>This function provides all the settings related to the device configuration</i>	Main Menu	
Rerange	<i>This function provides the transmitter rerange</i>	Sub Menu	
Rerange with pressure	<i>This function provides the transmitter rerange when a pressure source is available</i>	Sub Sub Menu	
Set LRV (0%)	<i>Set the Low Range Value at the applied pressure</i>	Utility	Auto Adjust
Set URV (100%)	<i>Set the Upper Range Value at the applied pressure</i>	Utility	Auto Adjust
Rerange no pressure	<i>This function provides the transmitter rerange when no pressure source is available</i>	Sub Sub Menu	
Engineering Unit	<i>Select the engineering units for the Engineering variable</i>	Utility	Enumerated
Set LRV	<i>Set the Lower Range Value at the defined value</i>	Utility	Numerical
Set URV	<i>Set the Upper Range Value at the defined value</i>	Utility	Numerical
Percentage Rerange	<i>This function provides the transmitter rerange when any pressure source is available related to the percentage value</i>	Sub Sub Menu	
Set LRV (0%)	<i>Set the Lower Range Value at the defined value in percentage</i>	Utility	Numerical
Set URV (100%)	<i>Set the Upper Range Value at the defined value in percentage</i>	Utility	Numerical
PV Scaling	<i>This function provides the Primary Variable Scaling</i>	Sub Menu	
Auto-Set Zero Scaling	<i>Shift the primary variable to zero</i>	Utility	Auto Adjust
PV Scaling	<i>Shift the primary variable to the defined pressure value</i>	Utility	Numerical
Reset PV Scaling	<i>Remove the existing Primary Variable Scaling</i>	Utility	Auto Adjust
Damping	<i>Set the damping value</i>	Utility	Manual Adjust
Output on Alarm	<i>This function provides the alarm settings</i>	Sub Menu	

Display indication	Description	Level	Type
Failure mode	Set the failure mode in down scale or upscale	Utility	Enumerated
Set fail current	This function provides the current values in case of output saturation or transmitter fail	Sub Sub Menu	
High saturation	Set the high saturation current at the desired value	Utility	Numerical
Low saturation	Set the low saturation current at the desired value	Utility	Numerical
Fail high	Set the high fail current at the desired value	Utility	Numerical
Fail low	Set the low fail current at the desired value	Utility	Numerical
Pressure Polarity	Set the pressure transmitter High pressure side	Utility	Enumerated
Transfer Function	This function provides the output transfer function setting	Sub Menu	
Type	Set the transmitter transfer function type	Utility	Enumerated
SW Write Protect	Set the write protection of the device	Utility	Enumerated
Display	This function provides all the settings related to the display configuration	Main Menu	
Language	Set the display language	Utility	Enumerated
Operator View	Set the Operator view mode	Utility	Enumerated
Display Variable 1	Set the display first line variable	Utility	Enumerated
Display Variable 2	Set the display second line variable	Utility	Enumerated
Display Bargraph	Set the bargraph variable	Utility	Enumerated
Contrast	Set the display contrast	Utility	Manual Adjust
Display Settings	This function has all the settings related with the variable on the display	Sub Menu	
Display Eng. unit	This function set the display to show the Engineering unit	Sub Sub Menu	
Pressure	Set the display to show the Engineering unit of pressure	Utility	Enumerated
Temperature	Set the display to show the Engineering unit of temperature	Utility	Enumerated
Level	Set the display to show the Engineering unit of level	Utility	Enumerated
Other	Set the display to show the Engineering unit not in the main list	Utility	Enumerated
Custom Unit	Set the display to show the customized Engineering unit	Utility	ASCII String
Set Display LRV (0%)	Set the display to show 0% at the defined Lower Range Limit	Utility	Numerical
Set Display URV (100%)	Set the display to show 100% at the defined Upper Range Limit	Utility	Numerical
Display Transfer Func	Set the display transfer function (independent from the output transfer function)	Utility	Enumerated
Security	This function set the security features	Sub Sub Menu	
Display Protection	Set the protection or remove the protection	Utility	ASCII String
Change Password	Modify the password	Utility	ASCII String
Communication	This function provides all the Communication settings	Main Menu	
HART Tag	Set the Tag value in the transmitter database	Utility	ASCII String
Descriptor	Set the Descriptor value in the transmitter database	Utility	ASCII String

Display indication	Description	Level	Type
Message	Set the Message value in the transmitter database	Utility	ASCII String
Polling Address	Set the Polling Address value in the transmitter database	Utility	Enumerated
Calibrate	This function provides all the Calibration settings	Main Menu	
Sensor Trim	This function provides the trimming of the sensor	Sub Menu	
Lower sensor trim	Set the lower Sensor Trim point	Utility	Numerical
Upper sensor trim	Set the upper Sensor Trim point	Utility	Numerical
Output Trim	This function provides all the trimming of the current output	Sub Menu	
Set 4 mA	Trim the output current to 4 mA when the action is performed	Utility	Numerical
Set 20 mA	Trim the output current to 20 mA when the action is performed	Utility	Numerical
Reset to Factory Trim	Set the output current Trim and the Sensor Trim at the Calibration performed in the factory during the transmitter manufacturing	Utility	Enumerated
Diagnostics	This function provides all the Diagnostics information	Main Menu	
Diagnostics	This function provides all the Main Diagnostics information	Sub Menu	
PV	Monitor the PV value	Utility	Numerical
HART Eng. Output	Monitor the HART Engineering Output value	Utility	Numerical
Output current	Monitor the Current Output value	Utility	Numerical
Output %	Monitor the Percentage Output value	Utility	Numerical
Sensor temperature	Monitor the Sensor temperature value	Utility	Numerical
Loop Test	This function provides to force the output current at a specific value	Sub Menu	
Set 4 mA	Set the output to 4 mA	Utility	Auto Adjust
Set 20 mA	Set the output current to 20 mA	Utility	Auto Adjust
Set custom value	Set the output current to a defined value	Utility	Manual Adjust

Digital LCD Integral Display view setting

To view the menu in a specific language:

Navigate the Digital LCD Integral Display menu, select **Display > Language**, and the used language will be available. To modify select *Edit* then scroll the desired language with the up and down keys and confirm with *OK*.

☞ Digital LCD Integral Display Keys sequence to set the language: 3 – 1 – Edit

To modify the Operator view:

Navigate the Digital LCD Integral Display menu, select **Display > Operator View**, and the used view will be available. To modify select *Edit* then scroll the desired Operator view (see the following table) with the up and down keys and confirm with *OK*.

<i>One Line</i>	to view the Variable 1 as defined in the Display
<i>One Line + Bargraph</i>	to view the Variable 1 as defined in the Display and the Bargraph proportional with the variable full scale
<i>Two Lines</i>	to view the Variable 1 and the Variable 2 as defined in the Display
<i>Two Lines + Bargraph</i>	to view the Variable 1 and the Variable 2 as defined in the Display and the Bargraph proportional with the variable full scale

☞ Digital LCD Integral Display Keys sequence to modify the Operator View: 3 – 2 – Edit

To define the Variable 1 in the Display:

Navigate the Digital LCD Integral Display menu, select **Display > Display Variable 1**, and the used variable will be available. To modify select *Edit* then scroll the desired Variable 1 view (see the following table) with the up and down keys and confirm with *OK*.

<i>Pressure</i>	to view the Primary Variable value
<i>Output %</i>	to view th Primary Variable in percentage
<i>Current Out</i>	to view the current Output value in mA
<i>Engineering Output</i>	to view the Output value in Engineering Units
<i>Sensor Temperature</i>	to view the Sensor Temperature value

☞ Digital LCD Integral Display Keys sequence to modify the define the Variable 1: 3 – 3 – Edit

To define the Variable 2 in the Display:

Navigate the Digital LCD Integral Display menu, select **Display > Display Variable 2**, and the used variable will be available. To modify select *Edit* then scroll the desired Variable 2 view (see the following table) with the up and down keys and confirm with *OK*.

<i>Pressure</i>	to view the Primary Variable value
<i>Output %</i>	to view th Primary Variable in percentage
<i>Current Out</i>	to view the current Output value in mA
<i>Engineering Output</i>	to view the Output value in Engineering Units
<i>Sensor Temperature</i>	to view the Sensor Temperature value

☞ Digital LCD Integral Display Keys sequence to modify the define the Variable 2: 3 – 4 – Edit

To define the Bargraph variable in the Display:

Navigate the Digital LCD Integral Display menu, select **Display > Display Bargraph**, and the used variable in the Bargraph will be available. To modify select *Edit* then scroll the desired Variable with the up and down keys for the Bargraph view (see the following table) and confirm with *OK*.

<i>Pressure</i>	to view the Primary Variable value
<i>Output %</i>	to view th Primary Variable in percentage
<i>Current Out</i>	to view the current Output value in mA
<i>Engineering Output</i>	to view the Output value in Engineering Units
<i>Sensor Temperature</i>	to view the Sensor Temperature value

☞ Digital LCD Integral Display Keys sequence to modify the define the Bargraph variable: 3 – 5 – Edit

To regulate the Display Contrast:

Navigate the Digital LCD Integral Display menu, select **Display > Contrast**, and the used contrast will be available. To modify the contrast use the up and down keys and confirm with **OK**.

☞ Digital LCD Integral Display Keys sequence to modify the define the Bargraph variable: 3 – 6

To define the Variable Engineering Units in the display:

Navigate the Digital LCD Integral Display menu, select **Display > Display Settings > Display Eng. Unit**, and the possible engineering variables will be available. To select the type push **Edit** and select with up and down keys; confirm with **OK**.

Pressure
Temperature
Level
Other
Custom Unit

The in-use unit for the type will be available. To modify select **Edit** then scroll the desired Unit with the up and down keys and confirm with **OK**.

☞ Digital LCD Integral Display Keys sequence to modify the define the Variable Engineering Units in the display: 3 – 7 - 1

To protect the Display from changes:

Navigate the Digital LCD Integral Display menu, select **Display > Security > Display Protection**, and the actual protection will be available (Unlock and Lock). To modify select **Edit** then scroll the desired protection with the up and down keys and confirm with **OK**.

☞ Digital LCD Integral Display Keys sequence to protect the Display: 3 – 8 – 1 – Edit

To change the Display Password:

The Display Password is a five digit string. The default value, at the transmitter delivery is *********. This default password does not give the possibility to lock

Navigate the Digital LCD Integral Display menu, select **Display > Security > Change Password**, and the current password will be available. To modify select **Edit** then scroll the desired alphanumeric symbol with the up and down keys and confirm with **Next**. Repeat the operation for the five digits and confirm with **OK**.

☞ Digital LCD Integral Display Keys sequence to change the Display password: 3 – 8 – 2 – Edit

HART Transmitter

Accessing Communication data

The Operation data access could be necessary to look or verify the transmitter configuration.

Accessing Communication data by Digital LCD Integral Display

To access the transmitter communication data:

Navigate the Digital LCD Integral Display menu, select **Communication**, scroll the submenu with the up and down keys select one of the following submenu:

<i>Hart Tag</i>	to view e modify the transmitter Tag
<i>Descriptor</i>	to view e modify the transmitter Descriptor
<i>Message</i>	to view e modify the transmitter Message
<i>Polling Address</i>	to view the polling address

To modify select **Edit** then scroll the desired alphanumeric symbol with the up and down keys and confirm with **Next**. Repeat the operation for the necessary digits and confirm with **OK**

☞ Digital LCD Integral Display Keys sequence to access the transmitter communication data: 5

Accessing Communication data by CoMeter

Accessing Communication data by CoMeter is available with the 695 Field Indicator. Please refer to the device manual for the appropriate operations.

Accessing Communication data by HHT

Accessing Communication data by Hand Held Terminal is available. Please refer to the device manual for the appropriate operations.

Accessing Communication data by PC

Accessing Communication data by PC is available using dedicated Software. ABB can provide the references and the Software. Please refer to the Software instructions for the appropriate operations.

Accessing Operation data

The Operation data access could be necessary to look or verify the transmitter configuration.

Accessing Operation data by Digital LCD Integral Display

To access the transmitter measured variables:

Navigate the Digital LCD Integral Display menu, select **Diagnostics > Diagnostics**, scroll the submenu with the up and down keys select one of the following submenu:

<i>PV</i>	to monitor the measured Primary Variable
<i>Hart Eng. Output</i>	to access the Output value in Engineering Units
<i>Output Current</i>	to access the Output value in mA
<i>Output %</i>	to access the Output value in percentage
<i>Sensor Temperature</i>	to access the measured sensor temperature

☞ Digital LCD Integral Display Keys sequence to access the transmitter measured variables: 7 – 1

Accessing Operation data by CoMeter

Accessing Operation data by CoMeter is available with the 695 Field Indicator. Please refer to the device manual for the appropriate operations.

Accessing Operation data by HHT

Accessing Operation data by Hand Held Terminal is available. Please refer to the device manual for the appropriate operations.

Accessing Operation data by PC

Accessing Operation data by PC is available using dedicated Software. ABB can provide the references and the Software. Please refer to the Software instructions for the appropriate operations.

Trimming and Calibration Set Up

The calibration requires a stable Pressure Generator and a Reference Pressure Indicator with the appropriate accuracy (at least 4 times better than the required accuracy of the transmitter/measuring-chain).

The pneumatic circuit shall be verified to exclude connection leakage problem or plugged lines.

The picture on the right show the complete test rigs that can be selectively used to suit the calibration for the Pressure (gauge) and the Differential transmitters.

Before the calibration ensure that:

- the required calibrated span (upper and lower range values) is within the span and range limits (URL and LRL) indicated on the nameplate
- the transmitter is properly powered and the electrical connections correctly made.
- the write protect switch, located on the electronics module is in position OFF (write allowed).
- When making the connection, please ensure that there are no residual fluids (for gaseous testing materials) or air bubbles (for fluid testing materials) in the connection lines, since they can lead to errors during inspection.

Make the electrical connections as indicated in the picture. Connect a precision milliammeter as shown and **remove the short circuit link**.

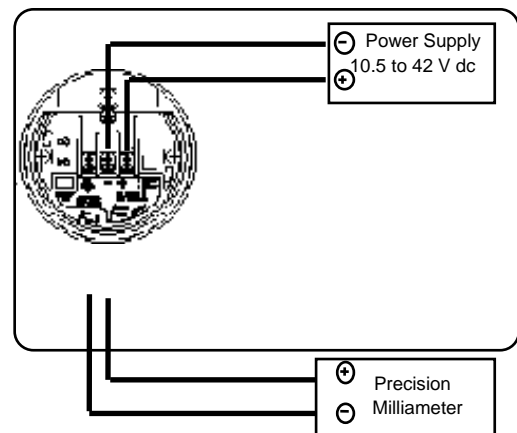
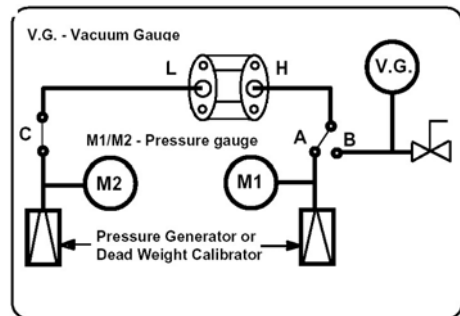

Sensor trim

The Sensor trim is a "set of operations, which establishes (by reference to standards) the relationship under specified conditions, between a reference indication and a result of a measurement" (International Vocabulary on Metrology).

In case the detected errors exceed the required accuracy, it is possible to correct the transmitter settings to compensate these errors.

**If the PV scaling has been performed the sensor trim is not available.
Reset the PV scaling before continuing the Sensor trim.**

NOTE: If this cannot be accomplished, the instrument may require a factory calibration or even its substitution.

Sensor Zero Trim

The Sensor Zero trim provide the correct offset of the factory characterization. The transmitter shall be within five percent of the true zero.

**If the PV scaling has been performed the sensor trim is not available.
Reset the PV scaling before continuing the Sensor trim.**

Sensor Zero trim by CoMeter

Sensor Zero trim by CoMeter is available with the 695 Field Indicator. Please refer to the device manual for the appropriated operations.

Sensor Zero trim by HHT

Sensor Zero trim by Hand Held Terminal is available. Please refer to the device manual for the right operations.

Sensor Zero trim by PC

Sensor Zero trim by PC is available using dedicated Software. ABB can provide the references and the Software. Please refer to the Software instructions for the right operations.

Sensor Low Trim

The Sensor Low trim provide the correct offset of the factory characterization. The transmitter shall be within five percent of the true value.

**If the PV scaling has been performed the sensor trim is not available.
Reset the PV scaling before continuing the Sensor trim.**

Sensor Low trim by Digital LCD Integral Display

Set the transmitter applied pressure as for Low trim value and wait for a stable value. Navigate the Digital LCD Integral Display menu, select **Calibrate > Sensor Trim > Lower Sensor Trim** and the Sensor Low trim values is available. To modify select **Edit** then scroll the desired value with the up and down keys and confirm with **Next**. Repeat the operation for the seven digits and confirm with **OK**.

The first digit is the sign (- or space for +) and one digit can be the dot. The Maximum and Minimum values are indicated on the Display as reference.

☞ Digital LCD Integral Display Keys sequence to Low Trim the sensor: 6 – 1 – 1 – Edit

Sensor Low trim by HHT

Sensor Low trim by Hand Held Terminal is available. Please refer to the device manual for the right operations.

Sensor Low trim by PC

Sensor Low trim by PC is available using dedicated Software. ABB can provide the references and the Software. Please refer to the Software instructions for the right operations.

Sensor High trim

Adjustment of the Sensor high trim value provides a slope correction to the characterization curve based on the low trim value.

**If the PV scaling has been performed the sensor trim is not available.
Reset the PV scaling before continue the Sensor trim.**

Sensor High trim by Digital LCD Integral Display

Set the transmitter applied pressure as for High trim value and wait for a stable value. Navigate the Digital LCD Integral Display menu, select **Calibrate > Sensor Trim > Upper Sensor Trim** and the Sensor High trim values is available. To modify select **Edit** then scroll the desired value with the up and down keys and confirm with **Next**. Repeat the operation for the seven digits and confirm with **OK**.

The first digit is the sign (- or space for +) and one digit can be the dot.

Note: the Maximum and Minimum values are indicated on the Display as reference.

☞ Digital LCD Integral Display Keys sequence to High Trim the sensor: 6 – 1 – 2 – Edit

Sensor High trim by HHT

Sensor High trim by Hand Held Terminal is available. Please refer to the device manual for the right operations.

Sensor High trim by PC

Sensor High trim by PC is available using dedicated Software. ABB can provide the references and the Software.

Sensor Static trim

The purpose of this procedure is to optimize transmitter performance by reducing the effect of static line pressure in these applications. 2600T Pressure transmitter Series does not normally require this procedure because optimization based on factory characterization occurs in the sensor. In any case this trim can be performed if required.

Static trim by HHT

Sensor Static trim by Hand Held Terminal is available. Please refer to the device manual for the right operations.

Static trim by PC

Sensor Static trim by PC is available using dedicated Software. ABB can provide the references and the Software.

Calibration

Calibration is an operation by which the LRV and URV are adjusted. It sets the 4 and 20 mA points at required pressures.

See Basic Configuration Function, Set the LRV and Set the URV for the procedures.

Output trimming (Digital to Analog trim)

The Analog Output Trim allows the adjustment of the transmitter's current output at the 4 and 20 mA points to match the plant standards. This command adjusts the digital to analog signal conversion.

Output trimming by Digital LCD Integral Display

To set the 4 mA output current

Connect the pressure transmitter as defined in the Trimming and Calibration Set Up. Using a precision milliamperometer read the current output. Navigate the Digital LCD Integral Display menu, select **Calibrate > Output Trim > Set 4 mA** and the value will be available. To modify select *Edit* then scroll the desired value with the up and down keys and confirm with *Next*. Repeat the operation for the seven digits to have the same reading of the milliamperometer and confirm with *OK*.

Note: the Maximum and Minimum values are indicated on the Display as reference.

☞ Digital LCD Integral Display Keys sequence to set the 4 mA output current: 6 – 2 – 1 – Edit

To set the 20 mA output current

Connect the pressure transmitter as defined in the Trimming and Calibration Set Up. Using a precision milliamperometer read the current at the output. Navigate the Digital LCD Integral Display menu, select **Calibrate > Output Trim > Set 20 mA** and the value will be available. To modify select *Edit* then scroll the desired value with the up and down keys and confirm with *Next*. Repeat the operation for the seven digits to have the same reading of the milliamperometer and confirm with *OK*.

Note: the Maximum and Minimum values are indicated on the Display as reference.

☞ Digital LCD Integral Display Keys sequence to set the 20 mA output current: 6 – 2 – 2 – Edit

Output trimming by CoMeter

Output trimming by CoMeter is available with the 695 Field Indicator. Please refer to the device manual for the appropriate operations.

Output trimming by HHT

Output trimming by Hand Held Terminal is available. Please refer to the device manual for the appropriate operations.

Output trimming by PC

Output trimming by PC is available using dedicated Software. ABB can provide the references and the Software. Please refer to the Software instructions for the appropriate operations.

Additional calibration procedures

The 364 pressure transmitter models allow some useful procedures below described.

PV scaling

The PV scaling operation can be used to align the "zero" of the process (e.g.: the minimum tank level) with the "zero" reading of the transmitter. A configuration tool shall be use to perform this operation through digital communication.

After the PV scaling all the Sensor trimming operation are disabled.

There are two different ways to perform a PV scaling:

Method 1: apply to the transmitter a pressure that corresponds to the scaling value (offset) and perform the operation using the configuration tools (Digital LCD Integral Display, Hand Held Terminal and PC).

Method 2: calculate the scaling value (offset) and apply it to the transmitter following the operation available on the configuration tool (Hand Held Terminal and PC). With this method it is possible to perform a scaling operation even for a value different then zero.

PV scaling by Digital LCD Integral Display

As for method 1

Apply to the transmitter a pressure that corresponds to the scaling value, wait for a stable value. Navigate the Digital LCD Integral Display menu, select **Device Config** > *PV Scaling* > *Auto-Set Zero Scaling*.

To accept the operation select *OK* and wait for the end (a bargraph will indicate the working progress).

☞ Digital LCD Integral Display Keys sequence to Auto-Set Zero Scaling: 2 – 2 – 1 – OK

As for method 2

Navigate the Digital LCD Integral Display menu, select **Device Config** > *PV Scaling* > *PV Scaling*. To modify select *Edit* then scroll the desired value with the up and down keys and confirm with *Next*. Repeat the operation for the seven digits and confirm with *OK*.

Note: the Maximum (+ 80% of URL) and Minimum (- 80% of URL) usable values are indicated on the Display as reference.

☞ Digital LCD Integral Display Keys sequence to Set the PV Scaling: 2 – 2 – 2 – Edit

Set PV scaling by HHT

PV scaling by Hand Held Terminal is available. Please refer to the device manual for the appropriate operations.

Set PV scaling by PC

PV scaling by PC is available using dedicated Software. ABB can provide the references and the Software. Please refer to the Software instructions for the appropriate operations.

Removing PV scaling

In case the Sensor trimming operation is necessary the PV scaling (Sensor Offset) has to be removed.

Removing PV scaling by Digital LCD Integral Display

Navigate the Digital LCD Integral Display menu, select **Device Config** > *PV Scaling* > *Reset PV Scaling*. To accept the remove select *OK* and wait for the end (a bargraph will indicate the working progress).

☞ Digital LCD Integral Display Keys sequence to Remove the PV Scaling: 2 – 2 – 3 – OK

Removing PV scaling by HHT

PV scaling removing by Hand Held Terminal is available. Please refer to the device manual for the appropriate operations.

Removing PV scaling by PC

PV scaling removing by PC is available using dedicated Software. ABB can provide the references and the Software. Please refer to the Software instructions for the appropriate operations.

Zero suppression

Two different methods can be used for Zero suppression:

Method 1: after completion of the zero and span trim procedures, apply to the High Side connection (P2 as default) a pressure equal to the pressure to be suppressed. Allow time for pressure stabilization and then press the Zero local adjustment key (Z) located behind the terminal block for at least 2 second and release. After this operation the digital milliammeter reading should be 4mA and the Upper Range Value automatically moved to a value equal to the sum of the pressure to be suppressed and the previous calibrated span.

Method 2: use the zero and span procedure above but apply pressures equal to the Lower Range Value (LRV) and then to Upper Range Value (URV), press for at least 2 second and release, the Zero local adjustment key (Z) and Span local adjustment key (S) respectively.

Zero elevation

Two different methods can be used for Zero elevation:

Method 1: after completion of the zero and span procedure above apply to the Low Side connection (P1 as default) a pressure equal to the pressure to be elevated. Allow time for pressure stabilization and then the Zero local adjustment key (Z) located behind the cover for at least 2 second and release After this operation the digital milliammeter reading should be 4mA and the Upper Range Value (URV) is automatically moved to a value equal to the sum of the pressure to be elevated and the previous calibrated span.

Method 2: use the zero and span procedure above but apply pressures equal to the Lower Range Value (LRV) and then equal to the Upper Range Value (URV) press for at least 2 second and release the Zero local adjustment key (Z) and Span local adjustment key (S) respectively.

The LRV pressure will be applied to the Low Side connection (P1 as default) whereas the URV will be applied to the Low Side (P1 as default) or to the High Side (P2 as default) connection depending upon the whether the range is all negative or crosses zero.

Reset to Factory trim

The transmitter has in the memory the Sensor Low trim, the Sensor High trim and the Output trimming (Digital to analog trim) defined or calculated during the transmitter assembly. These data have been defined as Factory trim. The Reset to Factory trim allow the restoration of the as-shipped factory settings of the sensor trim and analog output trim.

The Reset to Factory trim is suggested in case wrong trim operations are performed and the transmitter is in an undefined condition (i.e.: inadvertent zero trim of an absolute pressure unit or inaccurate pressure source).

Reset to Factory Trim by Digital LCD Integral Display

Navigate the Digital LCD Integral Display menu, select **Calibrate > Reset to Factory Trim**. To modify select **Edit** then scroll the desired Factory Trim (see the following table) with the up and down keys and confirm with **OK**.

<i>Sensor Trim</i>	Provides the Sensor Low Trim and Sensor High Trim as defined during the factory transmitter assembly
<i>DAC Trim</i>	Provides the Output Current Trimming as during the factory electronics characterization
<i>Full Trim</i>	Provides the Sensor Low Trim and the Sensor High Trim as during the factory transmitter assembly and the Output Current Trimming as during the factory electronics characterization

☞ Digital LCD Integral Display Keys sequence to Reset to Factory Trim: 6 – 3 – Edit

Reset to Factory trim by HHT

Reset to Factory trim (Sensor and Output trim) by Hand Held Terminal is available. Please refer to the device manual for the right operations.

Reset to Factory trimming by PC

Reset to Factory trim (Sensor and Output trim) by PC is available using dedicated Software. ABB can provide the references and the Software. Please refer to the Software instructions for the right operations.

Software Write Protect

Changes can be prevented to the transmitter configuration data with the Software write protection. If the transmitter Software write protection is activated the transmitter will not accept any writes to its memory. Configuration changes, such as trim and reranging cannot take place.

Software Write Protect by Digital LCD Integral Display

Navigate the Digital LCD Integral Display menu, select **Device Config > SW Write Protect**. To change the status of the Software write protection select *Edit* then *Unlock* and *OK* to remove the protection or *Lock* and *OK* to insert the protection.

☞ Digital LCD Integral Display Keys sequence to Software Write Protect: 2 – 7 – Edit

Software Write Protect by HHT

Software write protection by Hand Held Terminal is available. Please refer to the device manual for the appropriate operations.

Software Write Protect by PC

Software write protection by PC is available using dedicated Software. ABB can provide the references and the Software. Please refer to the Software instructions for the appropriate operations.

HART Multidrop mode

The transmitter can work in the HART Multidrop mode with other transmitters on the same line. HHT and PC, using the dedicated Software (ABB can supply the references and the Software), can set this operative mode. Please refer to the device manual and the Software instructions for the right operations.

Maintenance

No specific maintenance actions are required on the 2600T Pressure transmitter Series.

Exterior cleaning

Please note the following points when cleaning the device:

- The cleaning agents used should not attack the surface and the seals (gasket and threads).
- Mechanical damage to the diaphragm (i.e.: due to pointed objects) must be avoided.

Field update

Each transmitter is labeled individually, so it is imperative that the approval codes on each label match exactly during upgrade. The label on the transmitter reflects the replacement model code for reordering an assembled unit with the required communication protocol.

The 2600T Pressure transmitter Series allows for electronics board upgrades. Two provided screws guide and secure the boards into place.

Replacement and Troubleshooting



WARNING !

Before you begin read "Safety" on page 3.

The display, secondary electronic, and transducer assemblies are not user-serviceable; however, they may be replaced. This section describes the dismantle, the replacement and the troubleshooting of these assemblies. Other components are not replaceable except at the factory. As an example the housing covers viewing glass. This because regulations do not permit field replacement of a broken or damaged glass as this would invalidate the enclosure's explosion proof rating. Therefore it is necessary to replace the entire damaged enclosure cap assembly.

Dismantling and reassembly

Dismantling and reassembly should not be carried out on site because of the risk of damage to components and printed circuits as a result of adverse environmental conditions such as humidity, dust, etc. The dismantling and reassembly procedures given below should be carried out in the listed order to avoid instrument damage. See the pictures at the end of the instructions for better understanding.

Operation required tools

- 3 mm Allen key (in the transmitter box)
- Small Phillips screwdriver
- Small flat-bladed screwdriver

Safety information for Dismantling and Reassembly

Read the following Safety information before to start any operation.



WARNING !

Only specialist personnel or ABB may undertake dismantling and reassembly of certified devices. Explosion-protected transmitters may only be repaired by the manufacturer or otherwise must be approved by a certified expert after the repairs!
Observe the relevant safety precautions before, during and after the repairs.



WARNING !

Process fluids and/or pressure retained in the transmitter primary unit can cause severe injury and death or damage to the equipment. It is the user responsibility to make sure that no pressure is applied before removing the instrument from service or when draining or venting.



WARNING !

For Hazardous classified Location installations, at least seven (7) threads on the cover must be engaged in order to meet the flameproof (explosion-proof) requirements.

**DANGEROUS FLUIDS**

In case of toxic or otherwise dangerous process fluid, take any precautions as recommended in the relevant Material Safety Data Sheet.

Dismantling

Disassembling the transmitter is possible to inspect, clean and repair it.

The Digital LCD Integral Display and Electronics dismantling are allowed. See the Sectional view as reference.



Transmitter Sectional View for the 364 models without Digital LCD Integral Display



Transmitter Sectional View for the 364 models with Digital LCD Integral Display

Replacement

Electronics replacement

For electronics replacement or update apply the following procedure:

1. Screw down completely the cover locking screw using the 3 mm Allen key
2. Unscrew and remove the cover
3. Unscrew the two fixing screws and remove the secondary electronic assembly
4. Unplug the sensor cable
5. Plug the sensor cable to the new secondary electronics. Fix the electronic circuit by its screws.
6. Refit the covers and tighten securely.
7. Unscrew the cover locking screw to secure the covers. **This is mandatory to meet "Flameproof requirements" for Hazardous Areas installation.**

Data saving in case of replacement

In case it is necessary to replace the secondary electronic (e.g.: fault, HART electronic release update) the configuration of the new electronics is automatically updated, via the primary electronics, when the 364XS is power cycled.

Digital LCD Integral Display installation or replacement

To install the integral display:

1. Look at the indication on the nameplate.



WARNING

In an Explosion-Proof/Flame-Proof installation, do not remove the transmitter covers when power is applied to the unit

2. Remove the housing cover.
3. Fit the Integral display onto the secondary electronic. At this purpose use the 6 pin insert, supplied with the meter, it should be positioned in order to connect the two female connectors with the indicator in the required position

Note that it is possible to select the rotation angle by selecting one of the four different connections rotated clockwise or counterclockwise with 90° steps.

4. Fit the windowed housing cover, turn it to seat the O-ring into the housing and then continue to hand tighten until the cover contacts the housing metal-to-metal

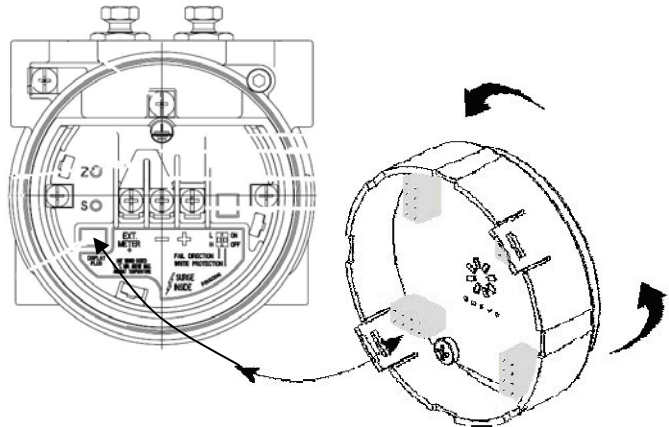

WARNING

In Ex d (Explosion Proof) installation, lock the cover rotation by turning the locking screws (use the 3 mm Allen key supplied with the instrument)

Troubleshooting

Suggestions for the most common operating problems are given in this User's Manual.

If you suspect malfunction despite the absence of any diagnostic messages on the display, follow the procedures described here to verify that transmitter hardware and process connections are in good working order.

Simple fault finding

In case the transmitter is not working properly, carry out the following fault finding checks before contacting your nearest Service Center.



WARNING

If the transmitter is working in a control loop, the loop must be placed under local manual control while the instrument is examined or taken out of service. Take all precautions to avoid damages caused by pressure or dangerous fluids release.

Symptom	Corrective actions
No output current	<ul style="list-style-type: none"> ▪ Check the transmitter power supply ▪ Verify terminal voltage is 10.5 to 42 V dc (or 30Vdc in Ex ia applications) ▪ Check power wires for reversed polarity ▪ Clean the electrical connections ▪ Replace the Electronics module
High, low or irregular output current	<ul style="list-style-type: none"> ▪ Check the transmitter power supply ▪ Verify applied pressure ▪ Verify 4 and 20 mA range points ▪ Verify output is not in alarm condition ▪ Verify if 4 – 20 mA output trim is required ▪ Check for trapped gas in liquid lines and liquid in dry lines ▪ Check for sediment in process flanges ▪ Clear the electronics module connectors contact ▪ Replace the Electronics module
Transmitter Not Communicating with HART Communicator	<ul style="list-style-type: none"> ▪ Verify the output is between 4 and 20 mA or saturation levels ▪ Verify clean DC Power to transmitter (Max AC noise 0.2 volts peak to peak) ▪ Check loop resistance, 250 ohm minimum ▪ Check if unit is addressed properly
Transmitter will not respond to changes in applied pressure	<ul style="list-style-type: none"> ▪ Check the test equipment ▪ Check impulse piping or manifold for blockage ▪ Verify applied pressure is between the Lower Range Limit and the Upper Range Limit ▪ Verify output is not in alarm condition ▪ Verify transmitter is not in Loop Test mode
Digital Pressure Variable reading is erratic	<ul style="list-style-type: none"> ▪ Check application for faulty equipment in pressure line ▪ Verify transmitter is not reacting directly to equipment turning on/off ▪ Verify damping is set properly for application
Milliamp reading is erratic	<ul style="list-style-type: none"> ▪ Verify power source to transmitter has adequate voltage and current ▪ Check for external electrical interference ▪ Verify transmitter is properly grounded ▪ Verify shield for twisted pair is only grounded at one end

Transmitter diagnostics

The transmitter provides some diagnostics messages to the user in case of faults or conditions out of the specification.

Diagnostic messages

Diagnostics messages are provided by Digital LCD Integral Display or by HART communication using the proper external tools.

Diagnostics on the Digital LCD Integral Display (HART version)

The diagnostics messages below listed can appear on the Digital LCD Integral Display. The corrective actions are also suggested (see the common corrective actions description at the end of the message list).

Electronic Fail

There are internal inconsistencies in the data base of the HART (secondary) electronic

Corrective actions: 1, 2, 3

Sensor Invalid

There are internal inconsistencies in the data base of the transducer (primary) electronic. This test is performed at the start up.

Corrective actions: 1, 2, 4

Sensor Fail

The reading from the sensor is wrong

Corrective actions: 1, 2, 4

PV out of Limit

The calculated PV is above 110% or below –110% of sensor limit (LRL/URL on the instrument nameplate).

Corrective actions: 5.

Overrange

The detected pressure is above the maximum static pressure (MWP on the instrument nameplate).

Corrective actions: 5.

Sensor T Out Lim

The sensor temperature is above + 90 °C or below – 50°C.

Corrective actions: 5.

Current Out Satur

The output is limited to the saturation limits, but the measurement is beyond these limits.

The measured variable could be outside the configured span.

Corrective actions: 5

Current Out Fixed

The output is fixed to a value set by a HART command for simulation purposes

Corrective actions: Use the HART command to exit the simulation mode. If the transmitter is not in simulation mode see 1, 2, 3.

DAC Out of Range

The Digital to Analog Converter (DAC) is out of range

Corrective actions: It is necessary to carry out an Output Trimming operation specified in this manual. If the error persists see 1, 2, 3 or 4.

Electr. T Out Lim

The temperature of the HART electronic is above 90 °C or below –50°C.

Corrective actions: Check the ambient temperature. If it is within the limits see 1, 2, 3.

Consistency Check

The secondary electronic and the primary electronics have not been working together before.

Corrective actions: If this message appears during a replacement, please follow the replacement instruction in the relevant section of this manual. If the error persists see 1, 2, 3 or 4

Config. Error

Bad configuration of range and/or transfer function.

Corrective actions: Please follow the setting configuration instruction in the relevant section of the this manual. If the error persists see 1, 2, 3 or 4

Sensor Elec. Fail

There are internal inconsistencies in the memory of the primary electronic. This test is performed at the start up.

Corrective actions: 1, 2, 4

Common corrective actions:

1. Switch the transmitter off and on to verify if the message appears again
2. With the HART command 48 it is possible to obtain additional information on the failed component
3. If the message persists the secondary electronic is suspected to have a failure. If the output is in a failure status (high or low) the fault is severe and it is necessary to substitute the secondary electronic. Otherwise the failure is minor, the signal is still valid but with a lower accuracy. The secondary electronic can be substituted when convenient.
4. If the message persists, the primary electronic could be damaged. If the output is in a failure status (high or low) the fault is severe and it is necessary to substitute the transducer. Otherwise the failure is minor, the signal is still valid but with a lower accuracy. The transducer can be substituted when convenient.
5. Check the process and ambient conditions (e.g.: pressure, process temperature, ambient temperature static pressure, etc.) against the sensor and electronics limits. If the conditions are close or outside the limits, these improper instrument utilization can have seriously compromised the instrument functionality. If the conditions are well inside the limits see the corrective actions of point 4 or 3.

Diagnostics on the CoMeter

The diagnostics messages on the Cometer and Prometer when installed on the 695 Field Indicator are available. Please refer to the device manual for the right operations.

Hart version diagnostics on the HHT

Hart version diagnostics on the Hand Held Terminal are available. Please refer to the device manual for the right operations.

Hart version diagnostics on thePC

Hart version diagnostics on the PC are available using dedicated Software. ABB can provide the references and the Software. Please refer to the Software instructions for the right operations.

Returns

When you send a defective transmitter to the repair department, include information describing the error and, if possible, the cause of each defective component.

Note

Use the return form on the next page.

This helps us perform the repairs quickly without having to contact you for further details.

Before you return the device, please clean it and pack it safely and securely.

When ordering spare parts or replacement devices, please always provide the serial number (S/N) of the original device as well as the year of manufacture.

Statement about the contamination of devices and components

The repair and/or maintenance of devices and components will only be performed when a completely filled out explanation is present.

Otherwise, the shipment can be rejected. This explanation may only be filled out and signed by authorized specialist personnel of the operator.

Customer details:

Company:

Address:

Contact person:

Telephone:

Fax:

E-Mail:

Device details:

Type:

Serial no.:

Reason for the return/description of the defect:

Was this device used for working with substances which pose a threat or health risk?

Yes No

If yes, which type of contamination (please place an X next to the applicable items)

biological	<input type="checkbox"/>	corrosive/irritating	<input type="checkbox"/>	combustible (highly/extremely combustible)	<input type="checkbox"/>
toxic	<input type="checkbox"/>	explosive	<input type="checkbox"/>	other toxic substances	<input type="checkbox"/>
radioactive	<input type="checkbox"/>				

Which substances have had contact with the device?

1.

2.

3.

We hereby certify that the devices/parts shipped were cleaned and are free from any dangerous or poisonous materials.

City, Date

Signature and company stamp

Disposal

The device is manufactured from materials that can be reused by specialized recycling companies.

WEEE directive 2002/96/EC

This transmitter is not subject to the WEEE directive 2002/96/EC and relevant national laws (e.g., ElektroG in Germany). The device must be disposed of at a specialized recycling facility.

Do not dispose of the device in the municipal garbage. Only privately used products may be disposed of in the municipal garbage according to the WEEE directive.

Note

Proper disposal prevents negative effects on people and the environment, and supports the reuse of valuable raw materials.

Materials

See "Technical data".

If it is not possible to dispose of old equipment properly, ABB Service can accept and dispose of returns for a fee.

Additional Safety Notes

Hazardous Area

According to ATEX Directive (European Directive 94/9/EC of 23 March 1994) and relative European Standards which can assure compliance with Essential Safety Requirements, i.e., EN 60079-0 (General requirements) EN 60079-1 (Flameproof enclosures "d") EN 50020 (Intrinsic safety "i") EN 50284 (Equipments, group II, category 1G) EN 50281 (Apparatus for use with combustible dusts), EN 60079-15 (Construction test and marking of type of protection "n" electrical apparatus), EN 60079-26 (Construction test and marking of group II zone 0 electrical apparatus).

The 364 pressure transmitter models (2600T series) have been certified for the below indicated groups, categories, media of dangerous atmosphere, temperature classes, types of protection.

Explosion protection

The device complies with the explosion-protection requirements of the directive 94/9/EC (ATEX):

When installing explosion-proof transmitters (e.g., electrical connection, ground/PE, etc.), observe national regulations, DIN/VDE standards and explosion-protection directives. The certified explosion-proof designation is provided on the name plate.

Type examination certificate / Declaration of conformity

For explosion-protected models, the EC type examination certificate or declaration of conformity must be observed and is part of this transmitter delivery.

Type of protection "Intrinsically safe Ex ia"

Install only intrinsically safe devices in the transmitter signal circuit. The signal circuit can be interrupted while the transmitter is in operation (e.g., clamping on/off signal lines).

The housing may be opened during operation.

Transmitters with in the type of-protection "intrinsically safe" may be set up directly near zone 0, if current is supplied via intrinsically safe electrical circuit in type of protection Ex ia.

Use in areas with combustible dust

Installation must be performed in accordance with EN 61241-14:2004.

Transmitters can only be connected using certified cable glands in accordance with directive 94/9/EC (ATEX) (not in delivery scope). The cable gland must also meet the IP 67 level of protection. Taking into consideration self-heating, the glowing temperature of the dust must be at least 85 K higher than the ambient temperature.

When using separating sensors with an anti-stick coating, be aware of the risk of a propagating brush discharge under consideration of the filling material and the delivery rate.

Certificate groups

Certificate ATEX II 1G Ex ia IIC T6 and II 1D Ex iaD 20 T85°C

ZELM certificate number ZELM 06 ATEX 0302 X

The meaning of ATEX code is as follows:

- II : Group for surface areas (not mines)
- 1 : Category
- G : Gas (dangerous media)
- D : Dust (dangerous media)
- T85°C: Maximum surface temperature of the transmitter enclosure with Ta (ambient temperature) +75°C for Dust (not Gas) with a dust layer up to 5 mm. For application with dust layer between 5 and 50 mm, maximum surface temperature must be consider according to IEC 61241-14 chapter 6.3.3.3.

Note: the number close to the CE marking of the transmitter safety label identifies the Notified Body which has responsibility for the surveillance of the production

The other marking refers to the protection type used according to relevant EN standards:

- Ex ia : Intrinsic safety, protection level "a"
- Ex iaD 20 : Construction with inside intrinsic safety electronics suitable for Dust-Zone20
- IIC : Gas group
- T6 : Temperature class of the transmitter (which corresponds to 85°C max) with a Ta (ambient temperature) +40°C

About the applications, this transmitter can be used in "Zone 0" (Gas) and "Zone 20" (Dust) classified areas (continuous hazard) as it is shown on the picture on the right.

Certificate ATEX II 1/2 G Ex ia IIC T6 and II 1/2D Ex iaD 21 T85°C

ZELM certificate number ZELM 06 ATEX 0302 X

Note: this ATEX Category depends on the application (see below) and also on the intrinsic safety level of the transmitter supply (associated apparatus) which can sometimes suitably be [ib] instead of [ia]. As it is well known, the level of an intrinsic safety system is determined by the lowest level of the various apparatus used, i.e., in the case of [ib] supply, the system takes over this level of protection.

The meaning of ATEX code is as follows:

- II : Group for surface areas (not mines)
- 1/2 : Category - It means that only a part of the transmitter complies with category 1 and a second part complies with category 2 (see picture on the right)
- G : Gas (dangerous media)
- D : Dust (dangerous media)
- T85°C: Maximum surface temperature of the transmitter enclosure with Ta (ambient temperature) +75°C for Dust (not Gas) with a dust layer up to 5 mm. For application with dust layer between 5 and 50 mm, maximum surface temperature must be consider according to IEC 61241-14 chapter 6.3.3.3.

Note: the number close to the CE marking of the transmitter safety label identifies the Notified Body which has responsibility for the surveillance of the production

The other marking refers to the protection type used according to relevant EN standards:

- Ex ia : Intrinsic safety, protection level "a"
- Ex iaD 21 : Construction with inside intrinsic safety electronics suitable for Dust-Zone21
- IIC : Gas group
- T6 : Temperature class of the transmitter (which corresponds to 85°C max) with a Ta (ambient temperature) +40°C

About the applications, this transmitter can be used in Zone "0" (Gas) classified areas (continuous hazard) with its "process part" only, whereas the remaining part of the transmitter, i.e. its enclosure, can be used in Zone 1 (Gas), only (see pictures on the right). Reason of this is the process part of the transmitter (normally called primary transducer) that provides inside separation elements to seal off the electrical sensor from the continuously hazardous process, according to the EN50284 and EN50018. About Dust application, the transmitter is suitable for "Zone 21" according to the EN 50281 as it is shown on the relevant part of the pictures on the right.

Application with Gas

Zone "0"



364 Tx
Category 1G
Ex ia

Note: the transmitter must be connected to a supply (associated apparatus) certified [Ex ia]

Application with Dust

Zone "20"



364 Tx
Category 1D
IP6x
(Ex ia)

Note: the protection is mainly assured by the "IP degree" associated to the low power from the supply certified [Ex ia]

Application with Gas

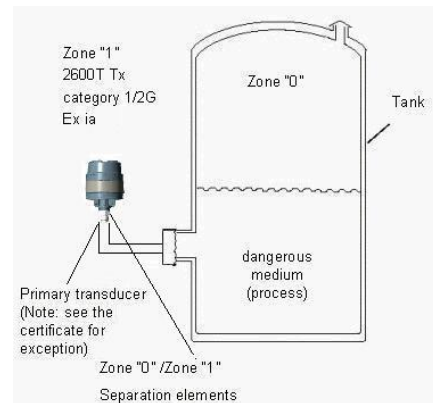

Note: the transmitter can be connected to either [ib] or [ia] supply (associated apparatus)

Application with Dust

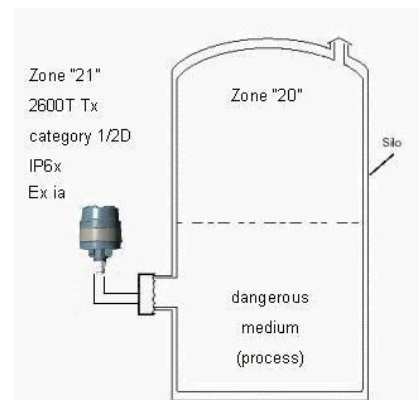

Note: the protection is mainly assured by the "IP degree" associated to the low power from the supply. This can either be [ib] or [ia]

Certificate ATEX II 1/2G Ex d IIC T6 and II 1/2D Ex tD A21 IP67 T85°C

ZELM certificate number ZELM 06 ATEX 0302 X

The meaning of ATEX code is as follows:

- II : Group for surface areas (not mines)
- 1/2 : Category - It means that only a part of the transmitter complies with category 1 and a second part complies with category 2 (see the picture on the right)
- G : Gas (dangerous media)
- D : Dust (dangerous media)
- T85°C: Maximum surface temperature of the transmitter enclosure with Ta (ambient temperature) +75°C for Dust (not Gas) with a dust layer up to 5 mm. For application with dust layer between 5 and 50 mm, maximum surface temperature must be consider according to IEC 61241-14 chapter 6.3.3.3.

Note: the number close to the CE marking of the transmitter safety label identifies the Notified Body which has responsibility for the Surveillance of the production.

The other marking refers to the protection type used according to relevant EN Standards:

- Ex d: Explosion proof/Flameproof
- Ex tD A21 : Construction with flameproof of protection method suitable for Dust-Zone 21
- IIC : Gas group
- T6 : Temperature class of the transmitter (which corresponds to 85°C max) with a Ta (ambient temperature) +75°C.

About the applications, this transmitter can be used in Zone "0" (Gas) classified areas (continuous hazard) with its "process part" only, whereas the remaining part of the transmitter, i.e. its enclosure, can be used in Zone 1 (Gas), only (see sketch below). Reason of this is the process part of the transmitter (normally called primary transducer) that provides inside separation elements to seal off the electrical sensor from the continuously hazardous process, according to the EN50284 and EN50018. About Dust application, the transmitter is suitable for "Zone 21" according to the EN 50281 as it is shown on the relevant part of pictures on the right.

Application with Gas

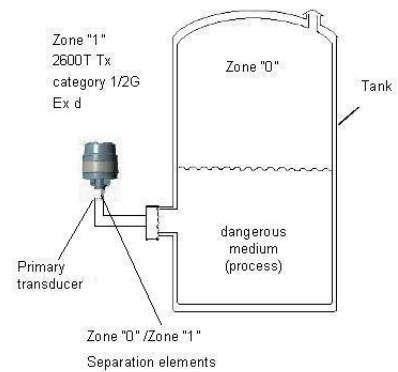

Application with Dust

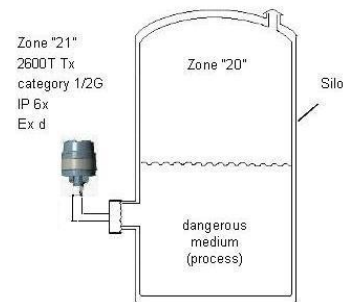

Note: the protection is mainly assured by the "IP degree" associated to the low power from the supply

Certificate ATEX II 3G Ex nL IIC T6 and II 3D Ex tD A22 IP67 T85°C

ZELM certificate number ZELM 06 ATEX 0302 X

The meaning of ATEX code is as follows:

- II : Group for surface areas (not mines)
- 3 : Category
- G : Gas (dangerous media)
- D : Dust (dangerous media)
- T85°C: Maximum surface temperature of the transmitter enclosure with Ta (ambient temperature) +75°C for Dust (not Gas) with a dust layer up to 5 mm. For application with dust layer between 5 and 50 mm, maximum surface temperature must be consider according to IEC 61241-14 chapter 6.3.3.3.

The other marking refers to the protection type used according to the standards:

- Ex nL : Type of protection "n" with "energy limitation" technique
- Ex tD A22 : Construction with flameproof of protection method suitable for Dust-Zone22
- IIC : Gas group
- T6 : Temperature class of the transmitter (which corresponds to 85°C max) with a Ta (ambient temperature) +40°C

Note: when installed this transmitter must be supplied by a voltage limiting device which will prevent the rated voltage of 42 V d.c. being exceeded.

About the applications, this transmitter can be used in "Zone 2" (Gas) and "Zone 22" (Dust) classified areas (unlikely/infrequent hazard) as it is shown on the picture on the right.

**Application with Gas
Zone "2"**



2600T Tx
Category 3G
(Ex nL)

Note: the transmitter must be connected to a supply with 42 V d.c. max output voltage as above indicated. The current of the transmitter is less than 25 mA.

Application with Dust



2600T Tx
Category 3D
IP 6x
(Ex nL)

Note: the protection is mainly assured by the "IP degree" associated to the low power from the supply.

Certificate **ATEX II 1G Ex ia IIC T6 and II 1/2G Ex ia IIC T6 and II 3G Ex nL IIC T6 and
II 1D Ex iaD 20 T85°C and II 1/2D Ex iaD 21 T85°C**

respectively **II 1/2G Ex d IIC T6 and II 1/2D Ex tD A21 IP67 T85°C and
II 3D Ex tD A22 IP67 T85°C**

ZELM certificate number ZELM 06 ATEX 0302 X

For special conditions for safe use see certificate

The meaning of ATEX code is as follows:

II : Group for surface areas (not mines)
1 : Category
1/2 : Category - It means that only a part of the transmitter complies with category 1 and a second part complies with category 2 (see on application sketch)
G : Gas (dangerous media)
D : Dust (dangerous media)
T85°C: Maximum surface temperature of the transmitter enclosure with Ta (ambient temperature) +75°C for Dust (not Gas) with a dust layer up to 5 mm. For application with dust layer between 5 and 50 mm, maximum surface temperature must be consider according to IEC 61241-14 chapter 6.3.3.3.

(Note: the number close to the CE marking of the transmitter safety label identifies the Notified Body which has responsibility for the surveillance of the production)

The other marking refers to the Intrinsic safety protection type used according to relevant EN standards:

Ex ia : Intrinsic safety, protection level "a"
Ex iaD 20 : Construction with inside intrinsic safety electronics suitable for Dust – Zone 20
Ex iaD 21 : Construction with inside intrinsic safety electronics suitable for Dust – Zone 21
IIC : Gas group
T6 : Temperature class of the transmitter (which corresponds to 85°C max) with Ta (ambient temperature) +40°C

The other marking refers to the Flameproof protection type used according to relevant EN standards:

Ex d: Flameproof
Ex tD A21 : Construction with flameproof of protection method suitable for Dust – Zone 21
Ex tD A22 : Construction with flameproof of protection method suitable for Dust – Zone 22
IIC : Gas group
T6 : Temperature class of the transmitter (which corresponds to 85°C max) with Ta (ambient temperature) +75°C.

About the applications of the transmitter see the relevant sketch.

"Ex Safety" Aspects for North America

According to Factory Mutual Standards which can assure compliance with Essential Safety Requirements

FM 3600 : Electrical Equipment for use in Hazardous (Classified) Locations, General Requirements.

FM 3610 : Intrinsically Safe Apparatus and Associated Apparatus for Use in Class I, II, III, Division 1, and Class I, Zone 0 & 1 Hazardous (Classified) Locations.

FM 3611 : Nonincendive Electrical Equipment for Use in Class I and II, Division 2 and Class III Division 1 and 2 Hazardous (Classified) Locations.

FM 3615 : Explosionproof Electrical Equipment.

FM 3810 : Electrical and Electronic Test, Measuring and Process Control Equipment.

NEMA 250 : Enclosure for Electrical Equipment (1000 Volts Maximum)

The 364AS and 364GS for use in Hazardous area installations according to FM (Factory Mutual) are supplied under the FM 797 revision report as the certification it is in progress. The construction of the 364GS and 364AS, as far as concerning Hazardous area protection, it's mainly based upon the already certified 364DS and 364PS.

The Factory Mutual certification will be applicable for the following Class, Divisions and Gas groups, hazardous classified locations, temperature class and types of protection.

- Explosionproof for Class I, Division 1, Groups A, B, C and D, hazardous (classified) locations.
- Dust Ignition proof for Class II, III Division 1, Groups E, F and G, hazardous (classified) locations.
- Suitable for Class II, III, Division 2, Groups F and G, hazardous (classified) locations.
- NonIncendive for Class I, Division 2, Groups A, B, C and D, in accordance with Nonincendive field wiring requirements for hazardous (classified) locations.
- Intrinsically Safe for use in Class I, II and III, Division 1, Groups A, B, C, D, E, F, and G in accordance with Entity requirements for hazardous (classified) locations.
- Temperature class T4 to T6 (dependent on the maximum input current and the maximum ambient temperature).
- Ambient Temperature range -50°C to +85°C (dependent on the maximum input current and the maximum temperature class).
- Electrical Supply range Minimum 10.5 Volts, Maximum 42 Volts (dependent on the type of protection, maximum ambient temperature, maximum temperature class and communication protocol).
- Type 4X applications Indoors/Outdoors.

NOTE

The 364 pressure transmitter models installed in Explosionproof Class 1 Division 1 Group A, B, C and D hazardous (classified) location does not require conduit sealing as per FM 3615 sect 4.3 / NEC 501.15.

For a correct installation in field of the 364 pressure transmitter models please see the related control drawing number DH3090.

Note that the associated apparatus must be FM approved.

According to CSA International Standards which can assure compliance with Essential Safety Requirements

C22.2

- 0-M1991** : General Requirements – Canadian Electrical Code Part II.
- 0.4-M1982** : Bounding and Grounding of Electrical Equipment (Protective Grounding)
- 0.5-M1982** : Threaded Conduit Entries
- 25-M1966** : Enclosures for use in Class II Groups E, F and G Hazardous Locations.
- 30-M1986** : Explosion-proof Enclosures for use in Class I Hazardous Locations.
- 94-M1991** : Special Purpose Enclosures.
- 213-M1987** : Non-Incendive Electrical Equipment for use in Class I Division 2 Hazardous Locations.
- 157-M1992** : Intrinsically Safe and Non-Incendive Equipment for use in Hazardous Locations.

CAN/CSA C22.2 No.1010.1-92

Safety Requirements for Electrical Equipment for Measurement, Control, and Laboratory Use, Part 1 : General Requirements (includes Amendment 1)

CAN/CSA C22.2 No.1010.1B-97

Amendment 2 to CAN/CSA C22.2 No 1010.1-92

CAN/CSA E60079-0-00

Electrical apparatus for explosive gas atmosphere. Part 0 : General Requirements.

CAN/CSA E60079-1-01

Electrical apparatus for explosive gas atmosphere. Part 1 : Construction and verification test of flameproof enclosure of electrical apparatus.

CAN/CSA E60079-11-02

Electrical apparatus for explosive gas atmosphere. Part 11 : Intrinsic Safety “i”

The 2600T Series pressure transmitters have been certified by CSA International for the following Class, Divisions and Gas groups, hazardous classified locations, temperature class and types of protection.

- Explosionproof for Class I, Division 1 and 2, Groups A, B, C and D; Class II Groups E, F and G; Class III; Enclosure Type 4X Ex d IIC.
- Non incendive for Class I, Division 2, Groups A, B, C and D; Class II Groups E, F and G; Class III; Enclosure Type 4X Ex nL IIC.
- Intrinsically Safe for Class I, Division 1 and 2, Groups A, B, C and D; Class II Groups E, F and G; Class III; Enclosure Type 4X Ex ia IIC.
- Temperature class T4 to T6 (dependent on the maximum input current and the maximum ambient temperature).
- Ambient Temperature range -50°C to +85°C (dependent on the maximum input current and the maximum temperature class).
- Electrical Supply range Minimum 10.5 Volts, Maximum 42 Volts (dependent on the type of protection, maximum ambient temperature, maximum temperature class and communication protocol).
- Type 4X applications Indoors & Outdoors.
- Pollution Degree I
- Installation Category II
- Altitude 2000 m
- Humidity 0 to 80%

For a correct installation in field of the 364 pressure transmitter models please see the related control drawing.

Note that the associated apparatus must be CSA approved.

Note for pressure transmitter with combined approval



WARNING

Before installing the Transmitter, the end user has to permanent mark on the nameplate his chosen Protection Concept (including general purpose in an unclassified location). The Transmitter can only be used according to this Protection Concept for the life of the product. **If more than one type of protection box (on safety label) are permanent marked, the Pressure Transmitter must be removed from hazardous classified locations.** The selected Type of Protection is allowed to be changed only by manufacturer after a new satisfactory assessment.

<p>ABB S.p.A. Lenno (Co) Italy</p>	Serial Number	Span Limits	Filling Fluid	<p>0722</p>
	Code		Diaphragms	
	Output Signal	MWP LRL	URL	<input type="checkbox"/> General Purpose IP67 Max.Supply Voltage 42 Vdc
<input type="checkbox"/>	XP CL I/DIV1/ABCD IS Ex ia SEC INTRINSEQUE CL I, ZONE 0, AEx ia IIC T6, T5, T4 IS Ex ia SEC INTRINSEQUE (ENTITY)CL I/DIV1/ABCD when connected per drawing DH 3090 ENCL 4X T AMB=85°C Max. hot spot T4 in 85°C Max AMB DIP CL II/III/DIV1/EFG "Factory Sealed"		<input type="checkbox"/> II 1/2 G Ex d IIC T6 and II 1/2 D Ex tD A21 IP67 T85°C ZELM 06 ATEX 0302X POWER SUPPLY 42 Vdc/ 2W MAX	<input type="checkbox"/> II 1 G Ex ia IIC T6 and II 1/2 G Ex ia IIC T6 and II 1D Ex iaD 20 T95°C and II 1/2 D Ex iaD 21 T95°C for electrical parameters see cert. ZELM 06 ATEX 0302X (IP 67)
<p>APPROVED</p>	<input type="checkbox"/> XP CL I/DIV1/ABCD IS CL 1, ZONE 0, AEx ia IIC T6, T5, T4 IS (Entity) CL I/DIV1/ABCD when connected per drawing DH 3090 ENCL 4X T AMB=85°C Max. hot spot T4 in 85°C Max AMB "Factory Sealed"			

Power supply operative limits

The transmitter operates on a minimum voltage of 10.5 Vdc to a maximum of 42 Vdc and is protected against polarity inversion.

Note The transmitter operates from 10.5 to 42 Vdc with no load (additional load allows operation over 42 Vdc). For EEx ia and intrinsically safe (FM, CSA and SAA) approval power supply must not exceed 30 Vdc. In some countries the maximum power supply voltage is limited to a lower value.

Minimum operating voltage is 15.3 Vdc if on terminals for external meter neither link nor remote indicator is present.

The total loop resistance is indicated in the expression below.

$$R \text{ (kohm)} = (\text{Supply voltage} - \text{Minimum operating voltage}) / 22.5 \text{ mA}$$

The total loop resistance is the sum of the resistance of all elements of the loop, including wiring, conditioning resistor, safety barriers and additional indicators (excluding the equivalent resistance of the transmitter). Where a configuration device (HART), such as the Hand Held Communicator or a Modem is likely to be used, a resistance of 250 ohm minimum should be present between the power supply and the point of insertion of these devices, to allow communication.

Several types of safety barriers, either passive or active, can be satisfactorily used in conjunction with the 364 pressure transmitter models. Nevertheless, in case of use of active barriers, check with the supplier if the model is suitable for use with smart transmitters allowing the connection of the configuration devices in the "safe" or non-hazardous area.

PED information integration**Compliance with pressure equipment directive (97/23/EC)****Devices with PS ≤ 200 bar (20 MPa)**

Devices with a permissible pressure ≤ 200 bar (20 MPa) conform to sec. 3 para. (3) and were not tested for conformity. The devices were constructed and manufactured according to valid sound engineering practice (SEP).

The CE marking on the device does not apply to the pressure equipment directive.

The name plate then contains the following identification codes: PED: SEP.

Ambient Temperature limits °C (°F):

Transmitters with Silicone oil filling:	between -40°C and +85°C (between -58°F and +185°F)
Lower ambient limit for LCD indicators:	-20°C (-4°F)
Upper ambient limit for LCD indicators:	+70°C (+158°F)

Process Temperature limits °C (°F):

Transmitters with Silicone oil filling:	between -40°C and +121°C (between -58°F and +250°F)
---	---

Storage Temperature limits °C (°F):

Lower limit	-50°C (-58°F); -40°C (-40°F) for Digital LCD Integral Display
Upper limit	+85°C (+185°F)
Relative Humidity	Up to 75%

Overpressure limits (without damage to the transmitter)

Lower limit	0.0 kPa abs, 0.0mbar abs, 0.00 psia
Upper limit	0.5MPa, 5bar, 72.5psi for sensor code L

2MPa, 20bar, 290psi for sensor code D
 6MPa, 60bar, 870psi for sensor code U
 20MPa, 200bar, 2900psi for sensor code R
 90MPa, 900bar, 13050psi for sensor code V

Electromagnetic compatibility (EMC)

Emission: Comply with EN 61000-6-3
 Immunity: Comply with EN 61000-6-2
 Radiated electromagnetic immunity level: 10V/m (according to IEC 1000-4-3, EN61000-4-3)
 Conducted electromagnetic immunity level: 10V (according to IEC 1000-4-6, EN 61000-4-6)
 Surge immunity level 2kV (according to IEC 1000-4-5 EN 61000-4-5)
 Fast transient (Burst) immunity level: 2kV (according to IEC 1000-4-4 EN 61000-4-4)

Humidity

Relative humidity: up to 100%
 Condensing, icing: admissible

Vibration resistance (according to IEC 60068-2-6)

Accelerations: up to 2g at frequency up to 1000Hz

Shock resistance (according to IEC 60068-2-27)

Acceleration: 50g
 Duration: 11ms

Wet and dust-laden atmospheres

The transmitter is dust and sand tight and protected against immersion effects as defined by IEC 60529 (1989) to IP 67 (IP 68 on request) or by NEMA to 4X.

Fill fluid warning

Be sure that the fill fluid can mix safely with the process fluid in case of rupture of the sensor membrane.

Corrosion

A fluid/material compatibility table is available at www.abb.com searching for "CORROSION.pdf" or from local ABB representatives

Data of the table are based on information from manufacturers.

All data is based on a temperature of 20°C (70°F) unless noted otherwise.

Since corrosion involves many more variables than this table considers, such as trace contaminants, aeration or temperature-concentration profile, stress corrosion cracking and pitting, the table should be used only as a reference in narrowing the choice of materials that merit further investigation. Suitability of a particular material is best determined by field test. For this purpose, please contact the local ABB representatives.

IP Protection

The 364 pressure transmitter models have been certified for a degree of protection IP67 according to EN 60529 standard. This protection is provided by the pressure transmitter enclosure.

The first characteristic numeral indicates the protection of the inside electronics against ingress of solid foreign objects including dusts. The assigned "6" means an enclosure dust-tight (no ingress of dust).

The second characteristic numeral indicates the protection of the inside electronics against ingress of water. The assigned "7" means an enclosure water-protected against a temporary immersion in water under standardized conditions of pressure and time.

Declarations

The 364 pressure transmitter models declarations are attached to this manual



EC DECLARATION OF CONFORMITY

We: ABB S.p.A. – ABB SACE Division
Business Unit Instrumentation
Via Statale, 113
22016 Lenno (Como)
Italy

declares under our sole responsibility that the products:

2600T EN Series (Transmitters models 364GS and 364AS),

are in conformity with the following standards:

<p>EN 61000-6-4 (2001) according to:</p>	<p>Electromagnetic compatibility (EMC) - Generic standards - Emission standard for residential, commercial and light-industrial environments EN55011 (2002)</p>
<p>EN 61000-6-2 (2001) according to:</p>	<p>Electromagnetic compatibility (EMC) - Generic standards - Immunity for industrial environments EN 61000-4-2 (2001) EN 61000-4-3 (2002) EN 61000-4-4 (2004) EN 61000-4-5 (2001) EN 61000-4-6 (2001) EN 61000-4-8 (2001) EN 61000-4-11 (2004)</p>

following the provisions of the EMC Directives 89/336/EEC and 93/68/EEC.

ABB S.p.A. – ABB SACE Division
Business Unit Instrumentation

Eugenio Volonterio
Technical Director

Lenno, 25th August 2008

ABB S.p.A.
ABB SACE Division

Una società del Gruppo ABB
An ABB Group company
Sede Legale
Registered Office:
Via Vittor Pisani, 16
I-20124 Milano - Italy
Tel.: +39 02 2414.1
www.abb.it

Direzione e Uffici Amministrativi
Headquarters and Accounting Services:
20099 Sesto S. Giovanni (MI) - Italy
Via L. Lama, 33
Tel.: +39 02 2414.1
Fax: +39 02 2414.3892
C.P./P.O. Box: 156 Milano
e-mail: sace.ssg@it.abb.com

Capitale Sociale
Share capital:
€ 107.000.000 i.v. /fully paid up
P. IVA/VAT: IT 11988960156
Codice Fiscale e n° di iscrizione del Registro
delle Imprese di Milano/Fiscal Code and
Official Company Book: 00736410150
R.E.A. Milano 1513225

Unità Produttive
Factories:
Bergamo
Frosinone
Garbagnate Monastero (LC)
Genova
Lenno (CO)
Marostica (VI)

Patrica (FR)
Santa Palomba (Roma)
S. Martino in Strada (LO)
Vittuone (MI)



EC-Declaration of Conformity

We ABB SpA
 BU Instrumentation
 Via Statale 113
 22016 Lenno (Como) Italy

declares under our sole responsibility that the products :

2600T Series Pressure Transmitter

Models :

364 ASL, 364ASD, 364ASU, 364ASR

364GSL, 364GSD, 364GSU, 364GSR

are in compliance with the requirements of 97/23/CE PED Directive

In accordance with article 3, comma 3, of the Directive itself because designed following the sound engineering practice (SEP)

Lenno 29/08/08

PED Certification Manager
 Business Unit Instrumentation

Walter Volo

ABB S.p.A.
 ABB SACE Division

Una società del Gruppo ABB
 An ABB Group company
 Sede Legale
 Registered Office:
 Via Vittor Pisani, 16
 I-20124 Milano - Italy
 Tel.: +39 02 2414.1
 www.abb.it

Direzione e Uffici Amministrativi
 Headquarters and Accounting Services:
 20099 Sesto S. Giovanni (MI) - Italy
 Via L. Lema, 33
 Tel.: +39 02 2414.1
 Fax: +39 02 2414.3892
 C.P./P.O. Box: 156 Milano
 e-mail: sace.ssg@it.abb.com

Capitale Sociale
 Share capital:
 € 107.000.000 I.v./fully paid up
 P. IVA/VAT: IT 11988960156
 Codice Fiscale e n° di iscrizione del Registro
 delle Imprese di Milano/Fiscal Code and
 Official Company Book: 00736410150
 R.E.A. Milano 1513225

Unità Produttive
 Factories:
 Bergamo
 Frosinone
 Garbagnate Monastero (LC)
 Lenno (CO)
 Marostica (VI)

Santa Palomba (Roma)
 S. Martino In Strada (LO)
 Vittuone (MI)

Annex I
Digital LCD Integral Display Menu Flow Chart

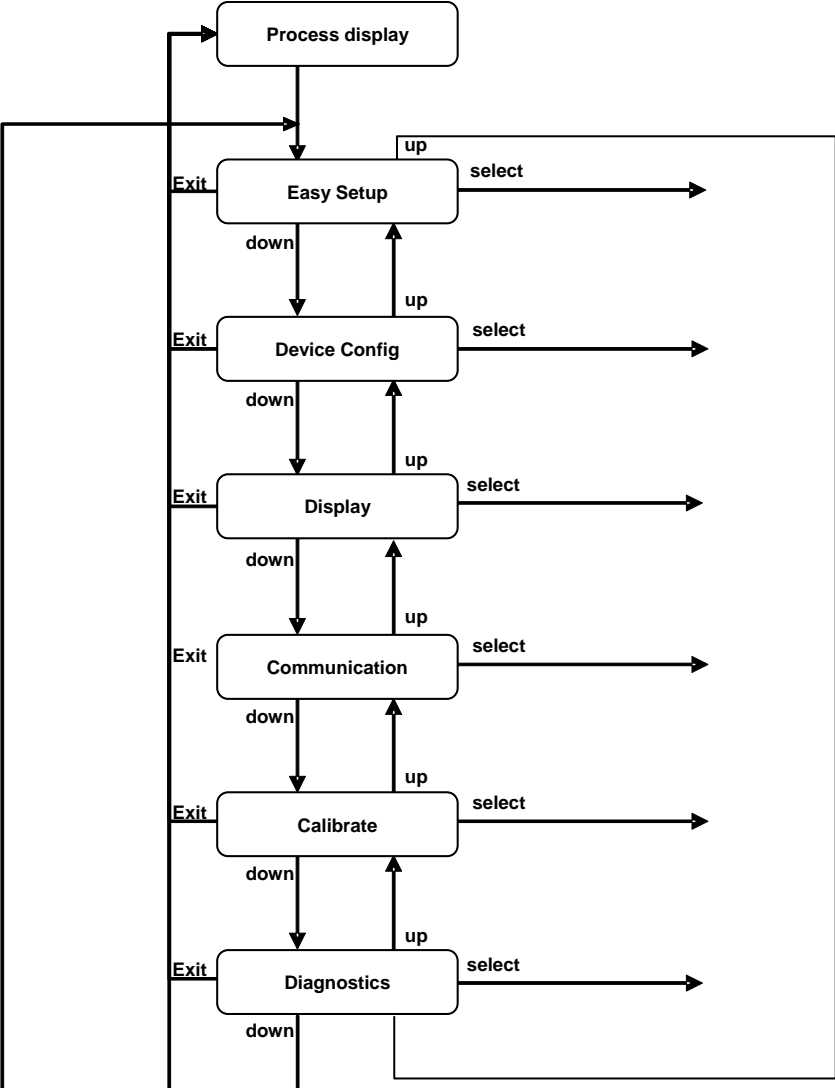

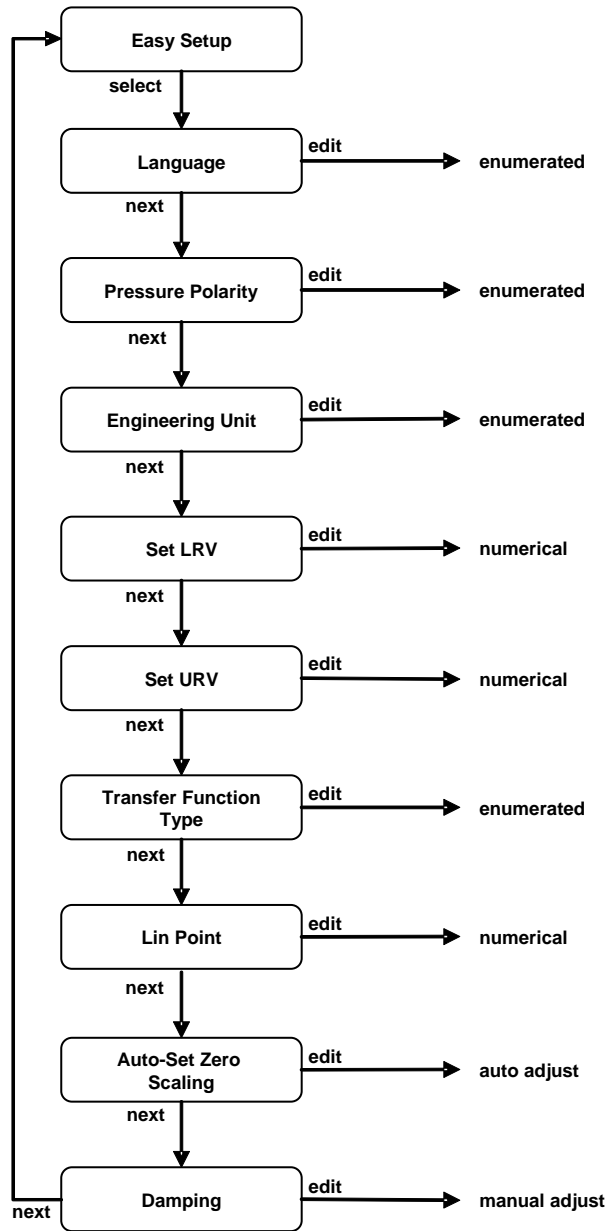

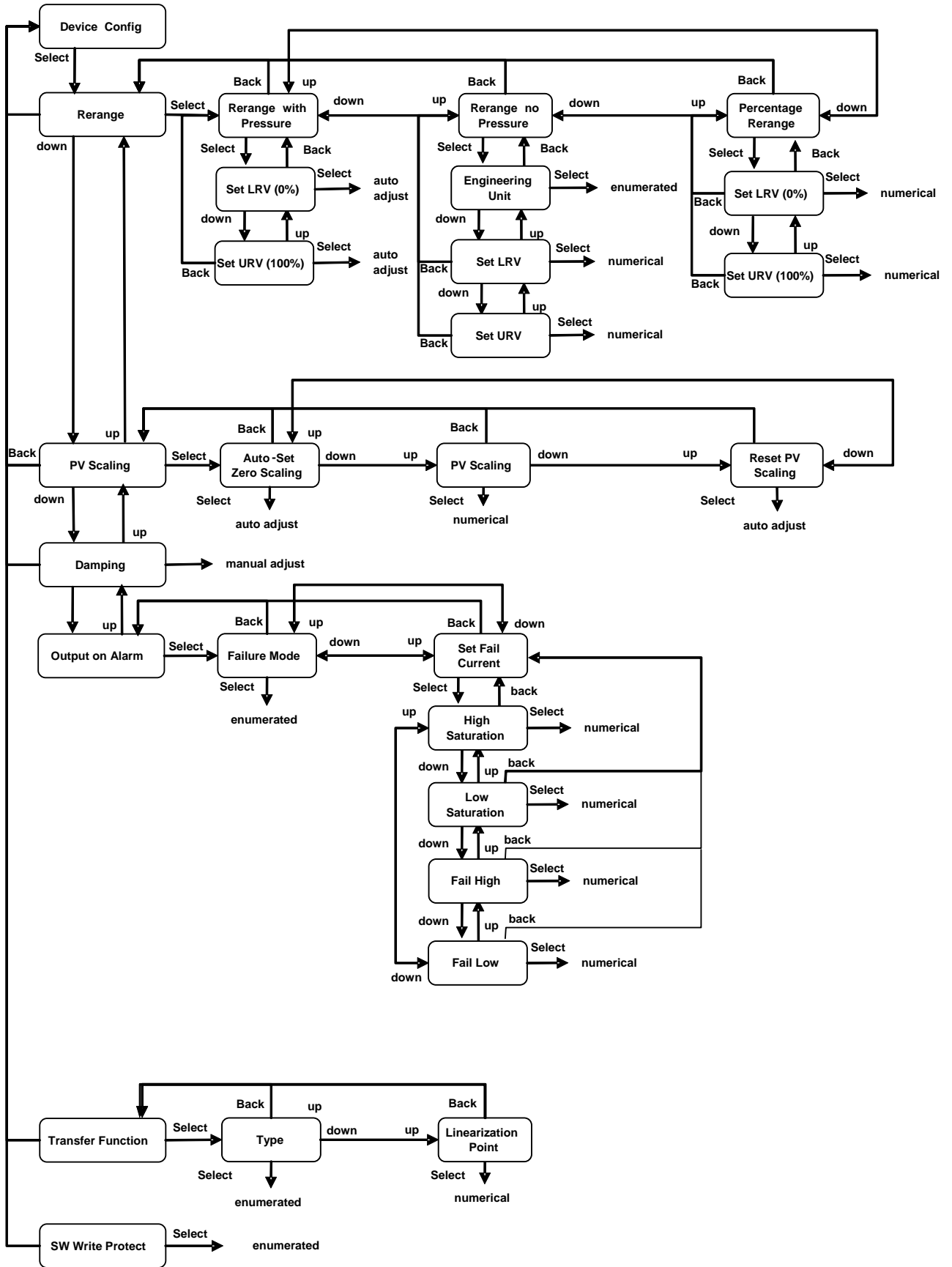

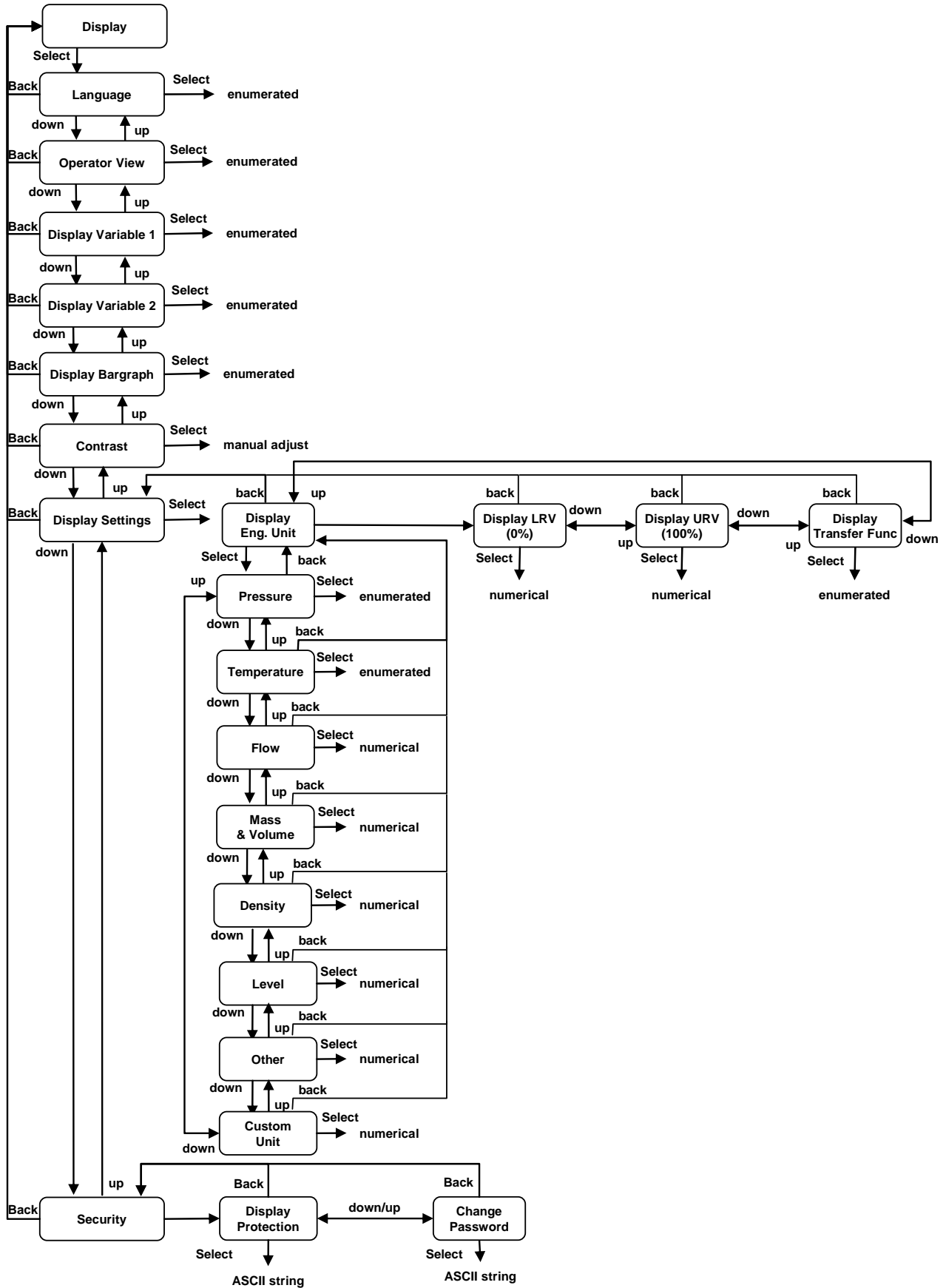

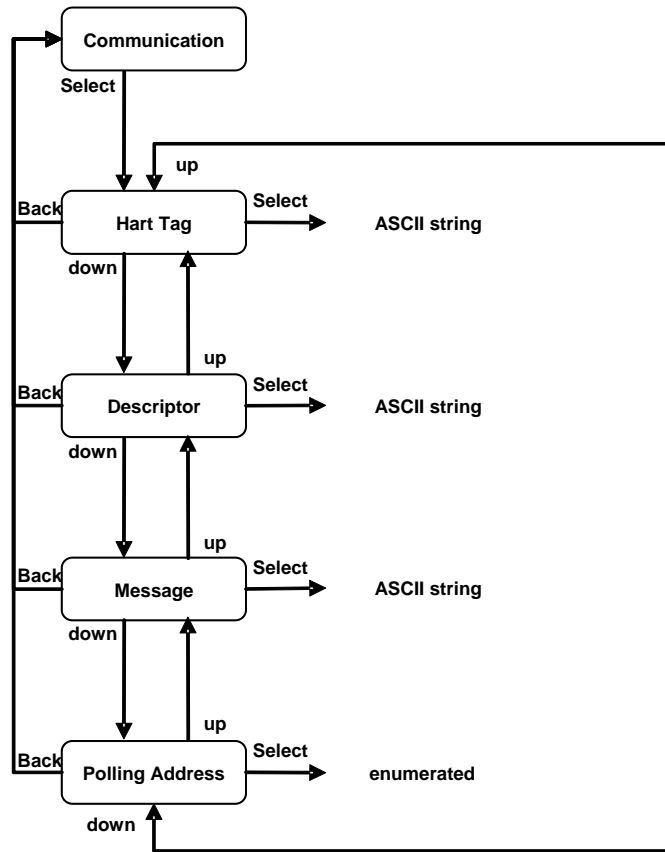

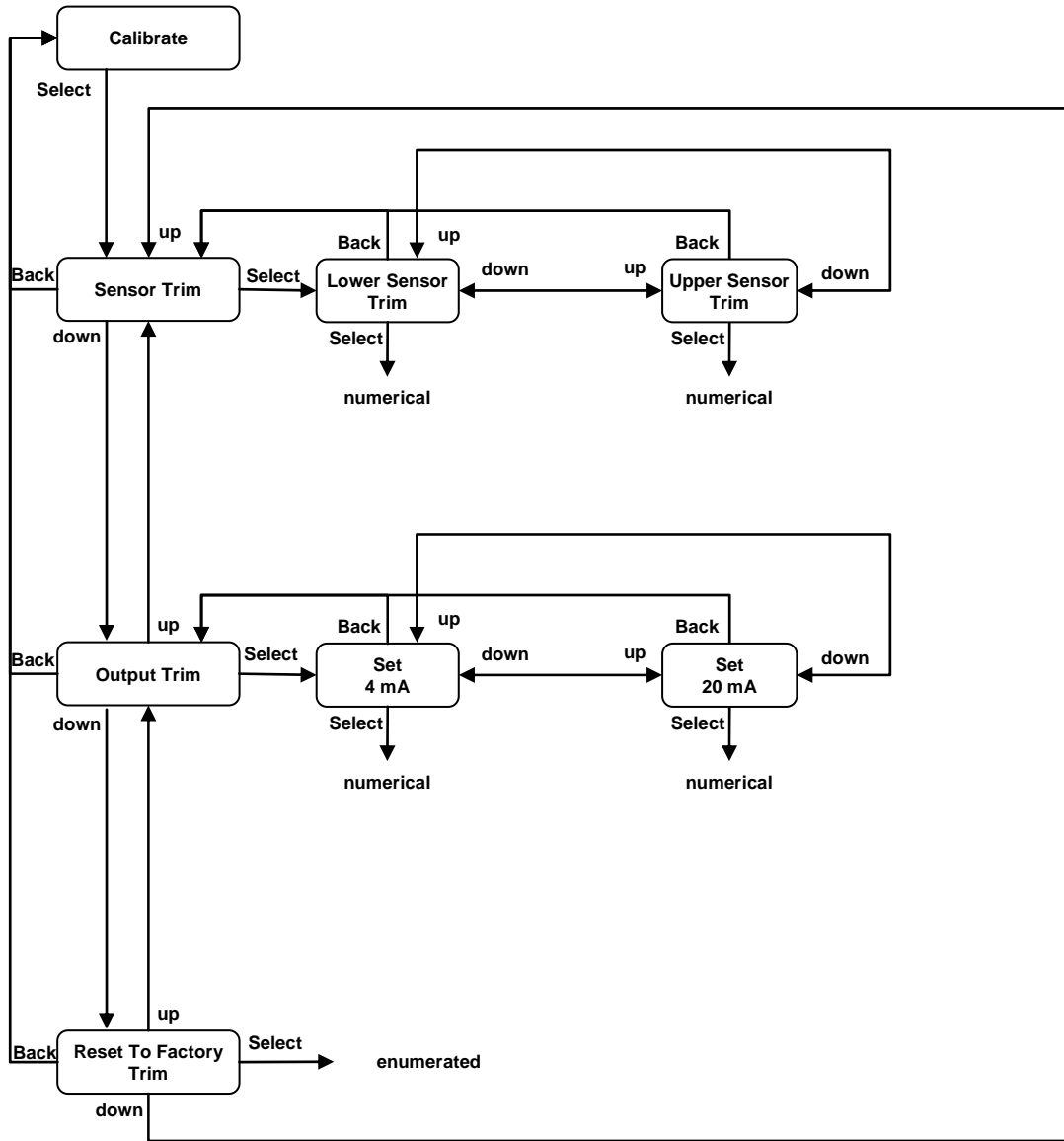

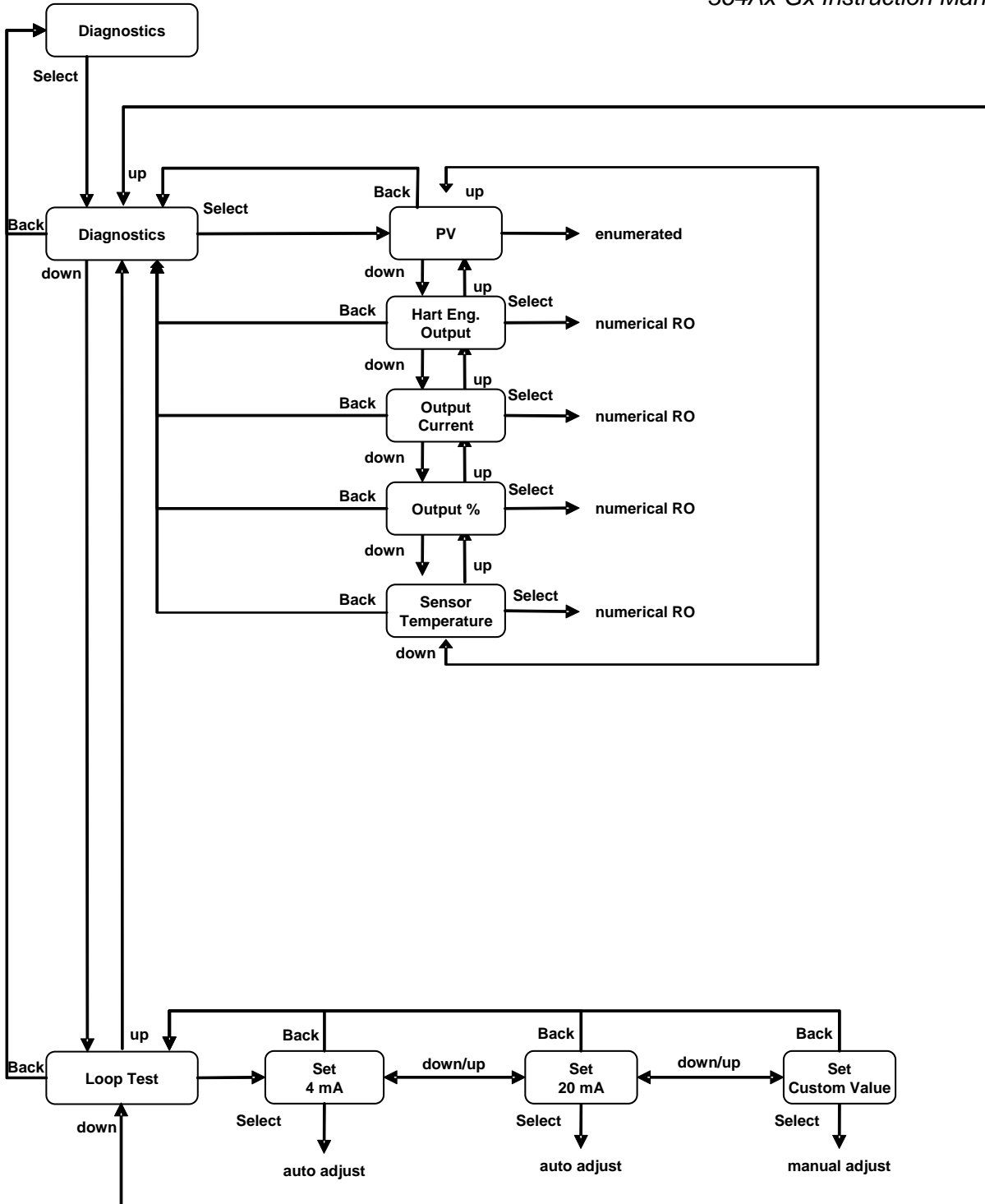

Main Digital LCD Integral Display Keys sequences:

to start the Easy Setup:	1
to to set the Damping:	2 – 3
to change the unit on the Display:	3 – 7 – 1
to change the unit in the Transmitter:	2 – 1 – 2 – 1 – Edit
to set the Display LRV :	3 – 7 – 2 - Edit
to set the LRV without pressure:	2 – 1 – 2 – 2 – Edit
to set the LRV without pressure:	2 – 1 – 1 – 1 – OK
to set the Display URV:	3 – 7 – 3 - Edit
to set the URV without pressure:	2 – 1 – 2 – 3 – Edit
to set the URV with pressure:	2 – 1 – 1 – 2 – OK
to set the Transfer Function:	2 – 6 – 1 – Edit
to set the Transfer Function on the Display:	3 – 7 – 4 – Edit
to set 4 mA fixed output current:	7 – 2 – 1
to set 20 mA fixed output current:	7 – 2 – 2
to set any fixed output current::	7 – 2 – 3
to change the failsafe direction:	2 – 4 – 1 - Edit
to set the High saturation current:	2 – 4 – 2 – 1 – Edit
to set the Low saturation current::	2 – 4 – 2 – 2 – Edit
to set the Fail High current:	2 – 4 – 2 – 3 - Edit
to set the Fail Low current::	2 – 4 – 2 – 4 - Edit
to set the language:	3 – 1 – Edit
to modify the Operator View:	3 – 2 – Edit
to modify the define the Variable 1:	3 – 3 – Edit
to modify the define the Variable 2:	3 – 4 – Edit
to modify the define the Bargraph variable:	3 – 6
to modify the define the Variable Engineering Units in the display:	3 – 7 - 1
to protect the Display:	3 – 8 – 1 – Edit
to change the Display password:	3 – 8 – 2 – Edit
to access the transmitter communication data:	5
to access the transmitter measured variables:	7 – 1
to Low Trim the sensor:	6 – 1 – 1 – Edit
to High Trim the sensor:	6 – 1 – 2 – Edit
to set the 4 mA output current:	6 – 2 – 1 – Edit
to set the 20 mA output current:	6 – 2 – 2 – Edit
to Auto-Set Zero Scaling:	2 – 2 – 1 – OK
to Set the PV Scaling:	2 – 2 – 2 – Edit
to Remove the PV Scaling:	2 – 2 – 3 – OK
to Reset to Factory Trim:	6 – 3 – Edit
to Software Write Protect:	2 – 7 – Edit

Acronyms

The acronyms currently used to define the various parameters are as follows:

- URL** : Upper Range Limit of a specific sensor. The highest value of the measured value that the transmitter can be adjusted to measure.
- LRL** : Lower Range Limit of a specific sensor. The lowest value of the measured value that the transmitter can be adjusted to measure.
- URV** : Upper Range Value. The highest value of the measured value to which the transmitter is calibrated.
- LRV** : Lower Range Value. The lowest value of the measured value to which the transmitter is calibrated.
- SPAN** : The algebraic difference between the Upper and Lower Range Values. The minimum span is the minimum value that can be used without degradation of the specified performance.
- LCD** Liquid Crystal Display
- CPU** Control Process Unit
- DSP** Digital Signal Processing
- DD** Device Description
- IS** Intrinsically Safety

Index

A

accessing communication data, 41
 accessing communication data, by cometer, 42
 accessing communication data, by hht, 42
 accessing communication data, by lcd, 41
 accessing communication data, by pc, 42
 accessing operation data, 42
 accessing operation data, by cometer, 42
 accessing operation data, by hht, 42
 accessing operation data, by lcd, 42
 accessing operation data, by pc, 42
 acronyms, 81

B

box, opening, 11

C

calibration, 45
 calibration, additional procedures, 46
 calibration, set up, 43
 certification, combined approval, 65
 certification, group, 59
 cleaning, 49
 configuration, 24
 configuration, default data, 24
 corrosion, 67
 current output limits, set by hht, 35
 current output limits, set by lcd, 35
 current output limits, set by pc, 35
 current output limits, set the limits, 35

D

damping, 25
 damping by cometer, 25
 damping, by hht, 25
 damping, by lcd, 25
 damping, by pc, 25
 declaration, 68
 diagnostic, 54
 diagnostic messages, 54
 diagnostics, on cometer, 55
 diagnostics, on hht, 55
 diagnostics, on lcd, 54
 diagnostics, on the pc, 55
 dismantling, 50
 dismantling, safety, 50
 dismantling, transmitter, 51

E

easy setup, 24
 electrical connections, 20
 electromagnetic compatibility, 67

F

failsafe direction, change, 34
 fault, simple finding, 53

field update, 49
 fixed output current, by cometer, 33
 fixed output current, by hht, 33
 fixed output current, by lcd, 33
 fixed output current, by pc, 33
 function, basic configuration, 25

H

handling, 12
 hardware settings, 34
 hazardous area, 58

I

installation, 13
 installation, apply power, 23
 installation, check, 22
 installation, mounting the transmitter, 14
 installation, preparing for, 13
 installation, start up, 23
 ip protection, 67

L

lcd, 36
 lcd, keys sequence, 80
 lcd, language, 39
 lcd, menu list, 36
 lcd, navigate, 36
 lcd, operator view, 40
lcd, password, 41
 lcd, positioning, 19
lcd, protection, 41
 lcd, transfer function, 33
 lcd, transfer function by hht, 33
 lcd, transfer function by pc, 33
 lcd, view setting, 39
 lrv, 27
 lrv, by cometer, 28
 lrv, by hht, 28
 lrv, by lcd, 27
 lrv, by local keys, 27
 lrv, by pc, 28

M

maintenance, 49
 menu, flowchart, 72
 meter, transfer function, 32
 mounting, 14
 mounting, on pipe, 15
 mounting, on pipe, instruction, 18
 mounting, on wall, 18
 mounting, on wall, instruction, 18
 multidrop, hart communication, 48

O

ouput trimming, by cometer, 46
 ouput trimming, by hht, 46
 ouput trimming, by lcd, 45

output trimming, by pc, 46

P

ped, 66
 plate, nameplate, 11
 plate, tag, 11
 plate, wired on, 12
 power supply, limits, 66
 protective earthing, 19
 pv scaling, 46
 pv scaling, by hht, 46
 pv scaling, by lcd, 46
 pv scaling, by PC, 46
 pv scaling, removing, 47
 pv scaling, removing by hht, 47
 pv scaling, removing by lcd, 47
 pv scaling, removing by PC, 47

R

reassembly, 50
 reassembly, safety, 50
 remote meter, 21
 replacement, 50, 52
 replacement, electronics, 52
 replacement, data saving, 52
 replacement, lcd, 52
 reset to factory trim, 47
 reset to factory trim, by hht, 48
 reset to factory trim, by lcd, 48
 reset to factory trim, by PC, 48

S

safety notes, 5
 safety, additional notes, 58
 sensor high trim, 44
 sensor high trim, by hht, 45
 sensor high trim, by lcd, 44
 sensor high trim, by pc, 45
 sensor low trim, 44
 sensor low trim, by hht, 44
 sensor low trim, by lcd, 44
 sensor low trim, by pc, 44
 sensor static trim, 45
 sensor static trim, by hht, 45
 sensor static trim, by pc, 45
 sensor trim, 43
 sensor trim, zero, 43
 sensor trim, zero by cometer, 44
 sensor trim, zero by hht, 44
 sensor trim, zero by pc, 44
 signal simulation, 33
 software settings, 34
 software write protect, 48
 software write protect, by hht, 48
 software write protect, by lcd, 48
 software write protect, by PC, 48
 storage, 12

T

transfer function, linear, 30

transfer function, polynomial, 30
 transfer function, two polynomial, 32
 transfer function, set, 32
 transfer functions, 29
 transfer functions, description, 30
 transmitter transfer function, by cometer, 32
 transmitter transfer function, by hht, 32
 transmitter transfer function, by lcd, 32
 transmitter transfer function, by pc, 32
 transmitter, identification, 11
 trimming, output, 45
 trimming, set up, 43
 troubleshooting, 50, 53

U

unit, by cometer and prometer, 27
 unit, by hht, 27
 unit, by pc, 27
 units, 25
 units, by lcd, 25
 urv, 28
 urv, by cometer, 29
 urv, by hht, 29
 urv, by lcd, 28
 urv, by local keys, 28
 urv, by pc, 29

W

wiring, 19
 write protect mode, HW, 34
 write protect mode, SW, 34

Z

zero elevation, 47
 zero suppression, 47

ABB has Sales & Customer Support
expertise in over 100 countries worldwide

www.abb.com/instrumentation

The Company's policy is one of continuous product
improvement and the right is reserved to modify the
information contained herein without notice

Printed in Italy (07.2010)

© ABB 2010



ABB Ltd
Howard Road, St. Neots
Cambridgeshire, PE19 3EU
UK
Tel: +44(0)1480 475321
Fax: +44(0)1480 217948

ABB Inc.
125 E. County Line Road
Warminster, PA 18974
USA
Tel: +1 215 674 6000
Fax: +1 215 674 7183

ABB S.p.A.
Via Statale 113
22016 Lenno (CO)
Italy
Tel: +39 0344 58111
Fax: +39 0344 56278

ABB Automation Products GmbH
Schillerstrasse 72
D-32425 Minden
Germany
Tel: +49 (0) 571 830 1691
Fax: +49 (0) 571 830 1368

IM/364GS_AS Rev 2