

Model 268DD Differential/Gauge Model 268HD Gauge Model 268ND Absolute

ABB 2600T Series
Engineered solutions
for all applications



TÜV SIL2 certified to IEC 61508

– the smart solution in Safety loop application

Best in Class Safety protection for your plants

- Safe Failure Fraction (SFF) : 98.6%
- Diagnostic Coverage (DC) : 97.7%
- Undetected Dangerous Failures λ_{DU} : 11 FIT

In-situ hardware redundancy (HFT=1)

– a guarantee of true protection

SIL3 capability in redundant architecture (1oo2)

– Software and hardware development process certified by TÜV

Reduced maintenance costs thanks to the longest proof test interval of 10 years for SIL2 in 1oo1 architecture

Base accuracy : $\pm 0.075\%$

Span limits

- 0.54 to 16000kPa; 2.14inH₂O to 2320psi
- 1.1 to 16000kPa abs; 8mmHg to 2320psia

Hardware and software redundancy with MTBF of over 100 years

Broad selection of variants, options, fill fluids and wetted materials

– allows total flexibility maximizing cost-effective aspect, also providing applications with critical process media at extended temperature range

PED compliance to sound engineering practice (SEP)

General Description

Model 268 is the IEC 61508 TÜV certified Safety 2600T transmitter for SIS and critical applications where safety and performances are the main requirement.

The transmitters detailed in this datasheets have been designed and manufactured according to a certified process which lead to a product specifically suitable for critical applications.

Thanks to the internal software and hardware redundancy, the 268 models have got the IEC 61508 certifications which not only allows installation in conformance with SIL2 (1oo1) but also to SIL3 in a 1oo2 architecture.

The 2600T Safety transmitter exceeds the IEC 61508 requirements for SIL2 with a Hardware Fault Tolerance of 1 (HFT = 1) and a Safe Failure Fraction of 98%.

In addition the following requirements of IEC 61508 have been assessed as part of the certification process:

- functional safety (hardware and software) testing;
- electrical safety testing;
- EMC testing;
- environmental testing;
- Quality Assurance in production and product maintenance;
- verification of the product development process.

Furthermore, with a very low Probability of Dangerous Undetected Failures ($\lambda_{DU} = 11$ FIT), the 2600T safety transmitters allow to extend the Proof Test Interval reducing maintenance costs by 50%.

Model 268DD, 268HD and 268ND detailed in this data sheet apply for those transmitters which include on high pressure measuring side, a direct mount seal which is integral to the transducer by a short capillary connection inside a protective rigid tube.

This construction forms a standalone single assembly suitable to be mounted to the process by the seal mounting facilities.

By properly selecting the high and low pressure side variant in the ordering codes model 268DD can be in the following versions :

- a) one direct mount seal and one flange for process connection, direct $1/4 - 18$ NPT or $1/2 - 14$ NPT through adapter; this allows also to connect the other leg (wet or dry) for differential measurement.

A proper filter is supplied as standard when $1/4 - 18$ NPT connection is selected, in order to plug the unused entry, leaving it vented for gauge measurement with reference to atmosphere.

- b) one direct mount seal and one remote seal with capillary; the two seals allow again a differential measurement and must be selected of same type/size.

Model 268HD and 268ND have the direct mount seal on the positive side, respectively with the reference at atmospheric or vacuum pressure, for gauge or absolute measurements.

Allowed types of direct mount seal are mainly used for chemical application:

- flush diaphragm flange mounted seal
- extended diaphragm flange mounted seal
- off-line threaded connection seal
- off-line flanged connection seal

These are suitable also for other process applications including food and sanitary, using FDA approved filling, which are defined as food fills and are Generally Recognized As Safe (GRAS) by the US Food and Drug Administration (FDA).

Refer to seal data sheet for all data and details relevant to seal element. The following table list the types of standard seal which can be mounted with 268DD, 268HD and 268ND transmitters (the mnemonic is used as reference in the compatibility table).

Model	Seal type	Size	Mnemonic
S264A S264E S264G S264R	Flanged flush diaphragm (also Ring Joint and JIS standard)	1-1/2in (ASME RJ only) 2in / DN50 / A50 3-4in / DN80-100 / A80-100	P1.5 P2 P3
	Flanged extended diaphragm	2in / DN50 3in / DN80 4in / DN100	E2 E3 P3
S264T	Threaded off-line	2 1/2in	T2.5
S264M	Flanged off-line	2 1/2in	T2.5
S264W (remote only)	Wafer Wafer food	1-1/2in / DN40 2in / DN50 3in / DN80	P1.5 P2 P3

All following specification data apply for identical characteristics of the two seals when the transmitter has the remote seal in addition to the direct mount one.

Functional Specifications

Range and span limits

Sensor Code	Upper Range Limit (URL)	Lower Range Limit (LRL)			Minimum span	Compatibility (allowed seal for 268DD)	
		268DD Direct mount differential	268DD Direct mount gauge	268HD/268ND Direct mount gauge/absolute		Direct mount seal only	Direct mount and one remote seal (max length in m.)
E	16kPa 160mbar 64inH ₂ O	-16kPa -160mbar -64inH ₂ O	-16kPa -160mbar -64inH ₂ O		0.54kPa 5.4mbar 2.14inH ₂ O	P2 (●), P3 E3 (●) T2.5	P3 (3) E3 (2) (●)
F	40kPa 400mbar 160inH ₂ O	-40kPa -400mbar -160inH ₂ O	-40kPa -400mbar -160inH ₂ O		0.67kPa 6.7mbar 2.67inH ₂ O	P2, P3 E2 (●), E3 T2.5	P2 (2) (●), P3 (5) E3 (3) T2.5 (2)
G	65kPa 650mbar 260inH ₂ O	-65kPa -650mbar -260inH ₂ O	-65kPa -650mbar -260inH ₂ O	-65kPa/0.07kPa abs (§) -650mbar/0.7mbar abs (§) -260inH ₂ O/0.5mmHg (§)	1.1kPa 11mbar 4.35inH ₂ O	P2, P3 E2 (●), E3 T2.5	P2 (2) (●), P3 (5) E3 (3) T2.5 (2)
H	160kPa 1600mbar 642inH ₂ O	-160kPa -1600mbar -642inH ₂ O	0.07kPa abs (§) 0.7mbar abs (§) 0.5mmHg (§)	0.07kPa abs (§) 0.7mbar abs (§) 0.5mmHg (§)	2.67kPa 26.7mbar 10.7inH ₂ O	P1.5 P2, P3 E2, E3 T2.5	P1.5 (2) P2 (5), P3 (8) E2 (4), E3 (6) T2.5 (6)
M	600kPa 6bar 87psi	-600kPa -6bar -87psi	0.07kPa abs (§) 0.7mbar abs (§) 0.5mmHg (§)	0.07kPa abs (§) 0.7mbar abs (§) 0.5mmHg (§)	10kPa 0.1bar 1.45psi	P1.5 P2, P3 E2, E3 T2.5	P1.5 (3) P2 (8), P3 (8) E2 (6), E3 (8) T2.5 (6)
P	2400kPa 24bar 348psi	-2400kPa -24bar -348psi	0.07kPa abs (§) 0.7mbar abs (§) 0.5mmHg (§)	0.07kPa abs (§) 0.7mbar abs (§) 0.5mmHg (§)	40kPa 0.4bar 5.8psi	P1.5 P2, P3 E2, E3 T2.5	P1.5 (5) P2 (8), P3 (8) E2 (6), E3 (8) T2.5 (6)
Q	8000kPa 80bar 1160psi	-8000kPa -80bar -1160psi	0.07kPa abs (§) 0.7mbar abs (§) 0.5mmHg (§)	0.07kPa abs (§) 0.7mbar abs (§) 0.5mmHg (§)	134kPa 1.34bar 19.4psi	P1.5 P2, P3 E2, E3 T2.5	P1.5 (5) P2 (8), P3 (8) E2 (6), E3 (8) T2.5 (6)
S	16000kPa 160bar 2320psi	-16000kPa -160bar -2320psi	0.07kPa abs (§) 0.7mbar abs (§) 0.5mmHg (§)	0.07kPa abs (§) 0.7mbar abs (§) 0.5mmHg (§)	267kPa 2.67bar 38.7psi	P1.5 P2, P3 E2, E3 T2.5	P1.5 (5) P2 (8), P3 (8) E2 (6), E3 (8) T2.5 (6)

The combinations sensor code/seal type marked (●) modify the base accuracy rating and static pressure effect; refer to performance specifications.

ALL AVAILABLE SEALS FOR DIRECT MOUNT ARE SUITABLE FOR LISTED RANGES OF MODELS 268HD/ND WITHOUT LIMITATION.

(§) Lower Range Limit is 0.135kPa abs, 1.35mbar abs, 1mmHg for inert Galden or 0.4kPa abs, 4mbar abs, 3mmHg for inert Halocarbon.

Span limits

Maximum span = URL
(can be further adjusted up to ± URL (TD = 0.5) for differential models, within the range limits)

IT IS RECOMMENDED TO SELECT THE TRANSMITTER SENSOR CODE PROVIDING THE TURNDOWN VALUE AS LOWEST AS POSSIBLE TO OPTIMIZE PERFORMANCE CHARACTERISTICS.

Zero suppression and elevation

Zero and span can be adjusted to any value within the range limits detailed in the table as long as:

– calibrated span ≥ minimum span

Damping

Selectable time constant : 0, 0.25, 0.5, 1, 2, 4, 8 or 16s.
This is in addition to sensor response time

Turn on time

Operation within specification in less than 1s with minimum damping.

Insulation resistance

> 100MΩ at 1000VDC (terminals to earth).

Operative limits

REFER ALSO TO S264 DATA SHEET FOR POSSIBLE FURTHER LIMITATION DUE TO SEAL VARIANTS AND FOR DATA RELEVANT TO THE POSSIBLE REMOTE SEAL (IF SELECTED ON NEGATIVE SIDE)

Temperature limits °C (°F) :

Ambient (is the operating temperature)

Filling	Model 268DD		Models 268HD/ND
	Sensors F to S	Sensor E	Sensors G to S
Silicone oil DC 200	-40 and +85 (-40 and +185)	-25 and +85 (-13 and +185)	-40 and +85 (-40 and +185)
Inert Galden	-20 and +85 (-4 and +185)	-10 and +85 (+14 and +185)	-20 and +85 (-4 and +185)
Inert Halocarbon	-20 and +85 (-4 and +185)	-10 and +85 (+14 and +185)	-20 and +85 (-4 and +185)

Lower ambient limit for LCD indicators: -20°C (-4°F)

Upper ambient limit for LCD indicators: +70°C (+158°F)

Note : For Hazardous Atmosphere applications see the temperature range specified on the certificate/approval relevant to the aimed type of protection

Process

Lower limit (side without seal for 268DD only)

- refer to lower ambient limits; -20°C (-4°F) for Viton gasket

Upper limit (side without seal for 268DD only)

- Silicone oil: 121°C (250°F) (1)

- Inert fluid: 100°C (212°F) (2)

(1) 100°C (212°F) for application below atmospheric pressure

(2) 65°C (150°F) for application below atmospheric pressure

The following table show characteristics of fill fluids when used in transmitters with direct mount seal on high pressure side.

FILL FLUIDS (APPLICATION)	OPERATING CONDITIONS			
	Tmax @ Pabs>of	Pmin mbar abs (psia)	Tmax @ P min	Tmin
Silicone oil-DC200 (General purpose)	200 (390) @ 35mbar	0.7 (0.01)	160 (320)	-40 (-40)
Silicone oil-DC704 (High temperature)	250 (480) @ 3.5mbar	0.7 (0.01)	220 (428)	-10 (+14)
Silicone Polymer-SylthermXLT (Low temperature)	100 (212) @ 110mbar	2 (0.03)	20 (68)	-100 (-148)
Vegetable oil-Neobee M-20 (Food-Sanitary) FDA	200 (390) @ 1bar	130 (1.9)	150 (300)	-18 (0)
Glycerin Water (70%) (Food-Sanitary) FDA	93 (200) @ 1bar	1000 (14.5)	93 (200)	-7 (+20)
Mineral oil-MARCOL 82 (Food-Sanitary) FDA	200 (390) @ 200mbar	33 (0.5)	40 (104)	-40 (-40)
Inert - Galden (Oxygen Service)	160 (320) @ 1bar	2 (0.03)	70 (158)	-20 (-4)
Inert - Halocarbon 4.2 (Oxygen Service)	180 (356) @ 400mbar	4 (0.06)	70 (158)	-20 (-4)

Fill fluids with FDA are defined as food fills and are Generally Recognized As Safe (GRAS) by the US Food and Drug Administration (FDA).

Limits for gaskets (flange to seal) of S264M and S264T

- Viton: -20°C (-4°F) to 200°C (392°F)

Limits for gaskets of flushing rings

Material	Pressure (max.)	Temperature (max.) (min.)		PxT limit (° F x psi)
Garlock	6.9MPa, 69bar, 1000psi	204° C (400° F)	-73° C (-100° F)	250000
Graphite	2.5MPa, 25bar, 362psi	380° C (716° F)	-100° C (-148° F)	
PTFE	6MPa, 60bar, 870psi	250° C (482° F)	-100° C (-148° F)	

Storage

Lower limit: -50°C (-58°F); -40°C (-40°F) for LCD indicators

Upper limit: +85°C (+185°F)

Pressure limits

Overpressure limits (without damage to the transmitter)

0.07kPa abs, 0.7mbar abs, 0.01psia (0.135kPa abs, 1.35mbar abs, 1mmHg for inert Galden or 0.4kPa abs, 4mbar abs, 3mmHg for inert Halocarbon) to transmitter sensor limit or flange rating of seal, whichever is less:

- 16MPa, 160bar, 2320psi for sensor code E of model 268DD

- 14MPa, 140bar, 2030psi for sensor codes G,H,M of model 268HD/ND

- 21MPa, 210bar, 3045psi for sensor codes F to S of model 268DD and for sensor codes P,Q,S of models 268HD and 268ND.

- maximum flange pressure rating (see tables below)

For model S264E flanged seal:

Rating/Class to EN 1092-1	Carbon Steel @ 120° C	AISI 316 Stainless Steel @ 20° C
PN16	16bar	16bar
PN40	40bar	40bar
PN63	63bar	63bar
PN100	100bar	100bar

For model S264A (RF) and S264R (RJ) flanged seal:

Rating/Class to ASME B16.5	Carbon Steel @100° F (38° C)	AISI 316 Stainless Steel @ 100° F (38° C)
Class 150	285psi	275psi
Class 300	740psi	720psi
Class 600	1480psi	1440psi
Class 900	2220psi	2160psi
Class 1500	3705psi	3600psi

For model S264G flanged seal:

Rating/Class to JIS B 2220	Carbon Steel @ 120° C	AISI 316 Stainless Steel @ 120° C
10K	14bar	14bar
20K	36bar	36bar
40K	68bar	68bar

For model S264M off-line flanged seal:

- Class 150 to ASME B16.5: 230psi @100°F (38°C)

- Class 300 to ASME B16.5: 600psi @100°F (38°C)

- PN16-40 to EN 1092-1: 34bar @20°C

For model S264W wafer or S264T off-line threaded connection seal:

- 16MPa, 160bar, 2320psi @20°C (68°F)

(but not greater than the wafer backup flange rating, not supplied)

The pressure limit decreases with increasing temperature above to the specified values as defined for the material, respectively for ASME B16.5, EN 1092-1 or JIS standards.

Static pressure

Transmitters for differential pressure model 268DD operates within specifications between the following limits:

- 1.3kPa abs, 13mbar abs, 0.2psia and 21MPa, 210bar, 3045psi (16MPa, 160bar, 2320psi for sensor code E) or flange rating of seal as above, whichever is less
- 0.07kPa abs, 0.7mbar abs, 0.01psia and 21MPa, 210bar, 3045psi (16MPa, 160bar, 2320psi for sensor code E) or flange rating of seal as above, whichever is less, using a second seal remote on negative pressure side.

Proof pressure

The transmitter can be exposed without leaking to line pressure of up to:

- 28MPa, 280bar, 4000psi for model 268DD and for sensor codes G,H,M of models 268HD and 268ND
- 40MPa, 400bar, 5900psi for sensor codes P,Q,S of models 268HD and 268ND

or two times the flange rating of seal, whichever is less.

Meet ANSI/ISA-S 82.03 hydrostatic test requirements.

Environmental limits**Electromagnetic compatibility (EMC)**

Comply with EN 61000-6-3 for emission and EN 61000-6-2 for immunity requirements and test;

Radiated electromagnetic immunity level: (according to IEC 1000-4-3, EN61000-4-3)	30V/m
Conducted electromagnetic immunity level : (according to IEC 1000-4-6, EN 61000-4-6)	10V
Surge immunity level (with surge protector): (according to IEC 1000-4-5 EN 61000-4-5)	4kV
Fast transient (Burst) immunity level: (according to IEC 1000-4-4 EN 61000-4-4)	4kV

Pressure equipment directive (PED)

Comply with 97/23/EEC following sound engineering practice (SEP).

Humidity

Relative humidity:	up to 100% annual average
Condensing, icing:	admissible

Vibration resistance

Accelerations up to 2g at frequency up to 1000Hz
(according to IEC 60068-2-6)

Shock resistance (according to IEC 60068-2-27)

Acceleration:	50g
Duration:	11ms

Wet and dust-laden atmospheres

The transmitter is dust and sand tight and protected against immersion effects as defined by EN 60529 (1989) to IP 67 (IP 68 on request) or by NEMA to 4X or by JIS to C0920. IP65 with Harting Han connector.

Hazardous atmospheres

With or without output meter

- INTRINSIC SAFETY and EXPLOSION PROOF/EUROPE:
ATEX/ZELM approval
II 1G Ex ia IIC T6 and II 1/2G Ex ia IIC T6 and
II 1D Ex iaD 20 T95°C and II 1/2D Ex iaD 21 T95°C
resp. II 1/2G Ex d IIC T6 and II 1/2D Ex tD A21 IP67 T85°C
- CANADIAN STANDARD ASSOCIATION and FACTORY MUTUAL:
 - Explosionproof: Class I, Div. 1, Groups A, B, C, D
 - Dust ignitionproof : Class II, Div. 1, Groups E, F, G
 - Suitable for : Class II, Div. 2, Groups F, G; Class III, Div. 1, 2
 - Nonincendive: Class I, Div. 2, Groups A, B, C, D
 - Intrinsically safe: Class I, II, III, Div. 1, Groups A, B, C, D, E, F, G
AEx ia IIC T6/T4, Zone 0 (FM)
- GOST (Russia), GOST (Kazakistan), Inmetro (Brazil - pending)
based on ATEX

Electrical Characteristics and Options

HART digital communication and 4 to 20mA output

Power Supply

The transmitter operates from 10.5 to 42VDC with no load and is protected against reverse polarity connection (additional load allows operations over 42VDC).

For EEx ia and other intrinsically safe approval power supply must not exceed 30VDC.

Ripple

20mV max on a 250Ω load as per HART specifications

MINIMUM OPERATING VOLTAGES

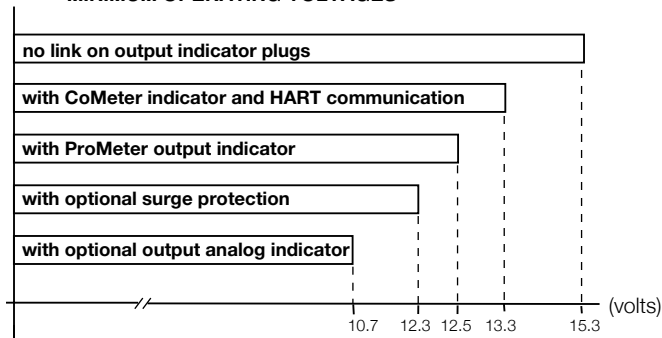

Load limitations

4 to 20mA and HART total loop resistance :

$$R(k\Omega) = \frac{\text{Supply voltage} - \text{min. operating voltage (VDC)}}{22.5}$$

A minimum of 250Ω is required for HART communication.

Optional indicators

Output meter

CoMeter and Prometer LCD:

5-digit (±99999 counts) programmable with 7.6mm. high (3in), 7-segment numeric characters plus sign and digital point for digital indication of output value in percentage, current or engineer unit;

10-segment bargraph display (10% per segment) for analog indication of output in percentage;

7-digit with 6mm. high (2.3in), 14-segment alphanumeric characters, for engineer units and configuration display

Analog : 36mm (1.4in) scale on 90°.

Optional surge protection

Up to 4kV

– voltage 1.2 μs rise time / 50 μs delay time to half value

– current 8 μs rise time / 20 μs delay time to half value

Output signal

Two-wire 4 to 20mA, user-selectable for linear or square root output, power of $3/2$ or $5/2$, 5th order or two 2nd order switching point selectable programmable polynomial output.

HART® communication provides digital process variable (% , mA or engineering units) superimposed on 4 to 20mA signal, with protocol based on Bell 202 FSK standard.

Output current limits (to NAMUR standard)

Low saturation: 3.8mA (field configurable from 3.5 to 4mA)

High saturation: 20.5mA (field configurable from 20 to 22.5mA)

Alarm current

Low alarm current: 3.7mA (field configurable from 3.5 to 4mA)

High alarm current: 22mA (field configurable from 20 to 22.5mA)

Factory setting: high alarm current

Performance specifications

Stated at reference condition to IEC 60770 ambient temperature of 20°C (68°F), relative humidity of 65%, atmospheric pressure of 1013hPa (1013mbar), mounting position with vertical diaphragm and zero based range for transmitter with isolating diaphragms in AISI 316 L ss or Hastelloy and silicone oil fill and digital trim values equal to span end points, in linear mode.

Unless otherwise specified, errors are quoted as % of span.

Some performance data are affected by the actual turndown (TD) as ratio between Upper Range Limit (URL) and calibrated span.

IT IS RECOMMENDED TO SELECT THE TRANSMITTER SENSOR CODE PROVIDING THE TURNDOWN VALUE AS LOWEST AS POSSIBLE TO OPTIMIZE PERFORMANCE CHARACTERISTICS.

Accuracy rating

% of calibrated span, including combined effects of terminal based linearity, hysteresis and repeatability.

For fieldbus versions SPAN refer to analog input function block outscale range

Using direct mount seal sizes <DN 80/3in

- ±0.075% for TD from 1:1 to 10:1
(±0.10% for sensor code F
±0.10% for sensor code E for TD from 1:1 to 5:1)

$$- \pm 0.0075\% \times \frac{\text{URL}}{\text{Span}} \text{ for TD from 10:1 to 20:1}$$

$$(\pm 0.01\% \times \frac{\text{URL}}{\text{Span}} \text{ for sensor code F}$$

$$\pm 0.02\% \times \frac{\text{URL}}{\text{Span}} \text{ for sensor code E for TD from 5:1 to 10:1)}$$

Using direct mount seal sizes ≥DN 80/3in

- ±0.075% for TD from 1:1 to 10:1
(±0.10% for sensor code E for TD from 1:1 to 5:1)

$$- \pm 0.0075\% \times \frac{\text{URL}}{\text{Span}} \text{ for TD from 10:1 to 20:1}$$

$$(\pm 0.02\% \times \frac{\text{URL}}{\text{Span}} \text{ for sensor code E for TD from 5:1 to 10:1)}$$

Multiply the values by 1.5 for sensor/seal combination marked (●) and for transmitter with direct mount seal plus one remote seal.

Operating influences

Temperature effects

per 20K (36 °F) ambient temperature change on transmitter sensor between the limits of -20°C to +65°C (-4 to +150°F) :

Transmitter effect:

- ±(0.04% URL + 0.065% span)

Direct mount seal additional effect:

Seal type size	Error		
	kPa	mbar	inH ₂ O
Flush 1-1/2in (RJ only)	0.52	5.2	2.09
Flush 2in/DN50/A50	0.12	1.2	0.48
Flush 3-4in/DN80-100/A80-100	0.02	0.2	0.08
Extended 2in/DN50	0.2	2	0.8
Extended 3in/DN80	0.06	0.6	0.24
Extended 4in/DN100	0.02	0.2	0.08
Off-line 2-1/2in	0.10	1	0.4

per 20K (36°F) process temperature change on seal diaphragm between the process operating temperature limits

Seal type size	Error		
	kPa	mbar	inH ₂ O
Flush 1-1/2in (RJ only)	0.85	8.5	3.4
Flush 2in/DN50/A50	0.32	3.2	1.28
Flush 3-4in/DN80-100/A80-100	0.1	1	0.4
Extended 2in/DN50	0.35	3.5	1.4
Extended 3in/DN80	0.17	1.7	0.68
Extended 4in/DN100	0.1	1	0.4
Off-line 2-1/2in	0.25	2.5	1

Optional CoMeter and ProMeter ambient temperature

Total reading error per 20K (36°F) change between the ambient limits of -20 and +70°C (-4 and +158°F) :

±0.15% of max span (16mA).

Static pressure (zero errors can be calibrated out at line pressure)

seal effect additional to transmitter sensor effect applicable for differential measurement per 2MPa, 20bar or 290psi.

Model 268DD direct mount seal only

- zero error: ±0.15% of URL
- span error: ±0.15% of reading

Model 268DD direct mount plus remote seal

- zero error: ±0.20% of URL
- span error: ±0.20% of reading

Multiply by 1.5 the errors for sensor/seal combinations marked (●).

Supply voltage

Within voltage/load specified limits the total effect is less than 0.005% of URL per volt.

Load

Within load/voltage specified limits the total effect is negligible.

Electromagnetic field

Total effect : less than 0.10% of span from 20 to 1000MHz and for field strengths up to 30V/m when tested with shielded conduit and grounding, with or without meter.

Common mode interference

No effect from 100Vrms @ 50Hz, or 50VDC

Vibration effect

±0.10% of URL (according to IEC 61298-3)

Physical Specification

(Refer to ordering information sheets of transmitter and seal(s) for variant availability related to specific model or versions code)

Materials

Model 268DD only

Low pressure side process isolating diaphragms (*)

AISI 316 L ss; Hastelloy C276™; Monel 400™; Tantalum; Hastelloy C276™ on AISI 316 L ss gasket seat.

A remote seal can be selected with required diaphragm material (refer to high pressure side).

Low pressure side process flanges, adapters, plugs and drain/vent valves (*)

AISI 316 L ss; Hastelloy C276™; Monel 400™.

Bolts and nuts

AISI 316 ss bolts Class A4–80 and nuts Class A4-70 per UNI 7323 (ISO 3506);

AISI 316 ss bolts and nuts Class A4–50 per UNI 7323 (ISO 3506), in compliance with NACE MR0175 Class II.

Gaskets (*)

Viton™; PTFE.

Model 268DD/HD/ND

High pressure side process diaphragm (direct mount seal) (*)

AISI 316 L ss; Hastelloy C276™; Hastelloy C2000™; Inconel 625; Tantalum; AISI 316 L ss or Hastelloy C276™ with anti-stick coating; AISI 316 L ss with anti-corrosion coating; AISI 316 L ss gold plated; Superduplex ss (UNS S32750 to ASTM SA479); Diaflex (AISI with anti-abrasion treatment).

Extension material

AISI 316 L ss (also for Diaflex and gold plated diaphragms); Hastelloy C276™; AISI 316 L ss or Hastelloy C276™ with coating same as diaphragm.

High pressure side fill fluid (direct mount seal)

Silicone oil-DC200™; Silicone oil-AN 140™; Inert-Galden™; Inert-Halocarbon™ 4.2; Silicone Polymer-Syltherm XLT™; Vegetable oil-Neobee M-20™; Glycerin Water; Mineral oil-MARCOL 82™.

Sensor fill fluid

Silicone oil (DC200™); inert fill (Halocarbon™ 4.2 or Galden™);

Sensor housing

AISI 316 L ss.

Electronic housing and covers

Barrel version

- Aluminium alloy with baked epoxy finish;
- Copper-free content aluminium alloy with baked epoxy finish;
- AISI 316 L ss.

DIN version

- Aluminium alloy with baked epoxy finish.

Covers O-ring

Buna N.

Local zero and span adjustments:

Glass filled polycarbonate plastic (removable).

Tagging

AISI 316ss data plate attached to the electronics housing.

Calibration

Standard: at maximum span, zero based range, ambient temperature and pressure;

Optional: at specified range and ambient conditions.

Optional extras

Output indicator

plug-in rotatable type, LCD or analog.

Supplemental customer tag

AISI 316 ss tag screwed/fastened to the transmitter for customer's tag data up to a maximum of 20 characters and spaces on one line for tag number and tag name, and up to a maximum of 3 spaced strings of 10 characters each for calibration details (lower and upper values plus unit). Special typing evaluated on request for charges.

Surge protection

Test Certificates (test, design, calibration, material traceability)

Tag and manual language

Communication connectors

Seal flushing ring (with relevant plugs and gasket)

Process connections

on conventional flanges : 1/4 – 18 NPT on process axis

on adapters : 1/2 – 14 NPT on process axis

fixing threads: 7/16 – 20 UNF at 41.3mm centre distance

on seal side (refer to drawings for details)

Flush diaphragm flanged seal (**):
 2in or 3in ASME 150 to 1500 RF; 4in ASME 150-300 RF;
 1-1/2in, 2in or 3in ASME 150 to 1500 RJ;
 DN50 or DN80 DIN PN16–40, PN63–100;
 DN100 PN16–40;
 A50 or A80 Class 10K, 20K, 40K
 A100 Class 10K, 20K.

Extended diaphragm flanged seal (**):
 2in, 3in or 4in ASME 150 - 300 RF;
 DN50, DN80 or DN100 PN16 – 40.

Off-line flanged connection seal (***)
 1/2in, 1in or 1-1/2in hole connection, ASME CL150-300;
 DN25 or DN40, EN PN16-40.

Off-line threaded connection seal
 1/4in, 1/2in, 3/4in, 1in or 1-1/2in NPT thread.

Gasket seat finish
 smooth (ASME, EN or JIS): 0.8µm (Ra)
 serrated (ASME or JIS): 3.2 to 6.3µm (Ra)
 serrated (EN 1092-1 Type B1; up to PN40): 3.2 to 12.5µm (Ra)
 serrated (EN 1092-1 Type B2; PN63-100): 0.8 to 3.2µm (Ra).

Wafer seal (remote only)
 1-1/2in, 2in or 3in to ASME;
 DN40, DN50 or DN80 to EN.

Electrical connections

Two 1/2 – 14 NPT or M20x1.5 or PG 13.5 or 1/2 GK threaded conduit entries, direct on housing.

Special communication connector (on request)

– HART : straight or angle Harting Han connector and one plug.

Terminal block

HART version: three terminals for signal/external meter wiring up to 2.5mm² (14AWG) and three connection points for test and communication purposes.

Grounding

Internal and external 6mm² (10AWG) ground termination points are provided.

Mounting position

Transmitter can be mounted in any position.

Electronics housing may be rotated to any position. A positive stop prevents over travel.

Mass (without options)

7kg to 50kg approx (15 to 110lb) according to specified seal(s) options; add 1.5kg (3.4lb) for AISI housing.
 Add 650g (1.5lb) for packing.

Packing

Carton

Configuration

Transmitter with HART communication and 4 to 20 mA

Standard configuration

Transmitters are factory calibrated to customer's specified range. Calibrated range and tag number are stamped on the tag plate. If a calibration range and tag data are not specified, the transmitter will be supplied with the plate left blank and configured as follows:

Engineering Unit	kPa
4 mA	Zero
20 mA	Upper Range Limit (URL)
Output	Linear
Damping	1 sec.
Transmitter failure mode	Upscale
Software tag (8 characters max)	Blank
Optional LCD indicator/display	0 to 100.0% linear

Any or all the above configurable parameters, including Lower range-value and Upper range-value which must be the same unit of measure, can be easily changed using the HART hand-held communicator or by a PC running the configuration software SMART VISION with DTM for 2600T. The transmitter database is customized with specified flange type and material, O-ring and drain/vent materials and meter code option. Custom configuration (option)

The following data may be specified in addition to the standard configuration parameters:

Descriptor	16 alphanumeric characters
Message	32 alphanumeric characters
Date	Day, month, year

For any protocol available engineering units of pressure measure are :
 Pa, kPa, MPa
 inH₂O@4°C, mmH₂O@4°C, psi
 inH₂O@20°C, ftH₂O@20°C, mmH₂O@20°C
 inHg, mmHg, Torr
 g/cm², kg/cm², atm
 mbar, bar

(*) Wetted parts of the transmitter.

(**) Bolts and nuts, gasket and mating flange supplied by customer.

(***) Gasket to process supplied by customer.

MOUNTING DIMENSIONS (not for construction unless certified) - dimensions in mm (in)

NOTE: For 268DD, low pressure side opposite to direct mount seal can be a conventional flange or suitable for capillary to remote seal.

Conventional process flange connection ($1/4 - 18$ NPT direct or $1/2 - 14$ NPT through adapter), gasket groove and gaskets are in accordance with DIN 19213. Bolting threads or fixing adapter for other devices on process flange is $7/16 - 20$ UNF.

268DD with barrel housing and direct mount seal S264A/S264E/S264G flanged Raised Face flush diaphragm

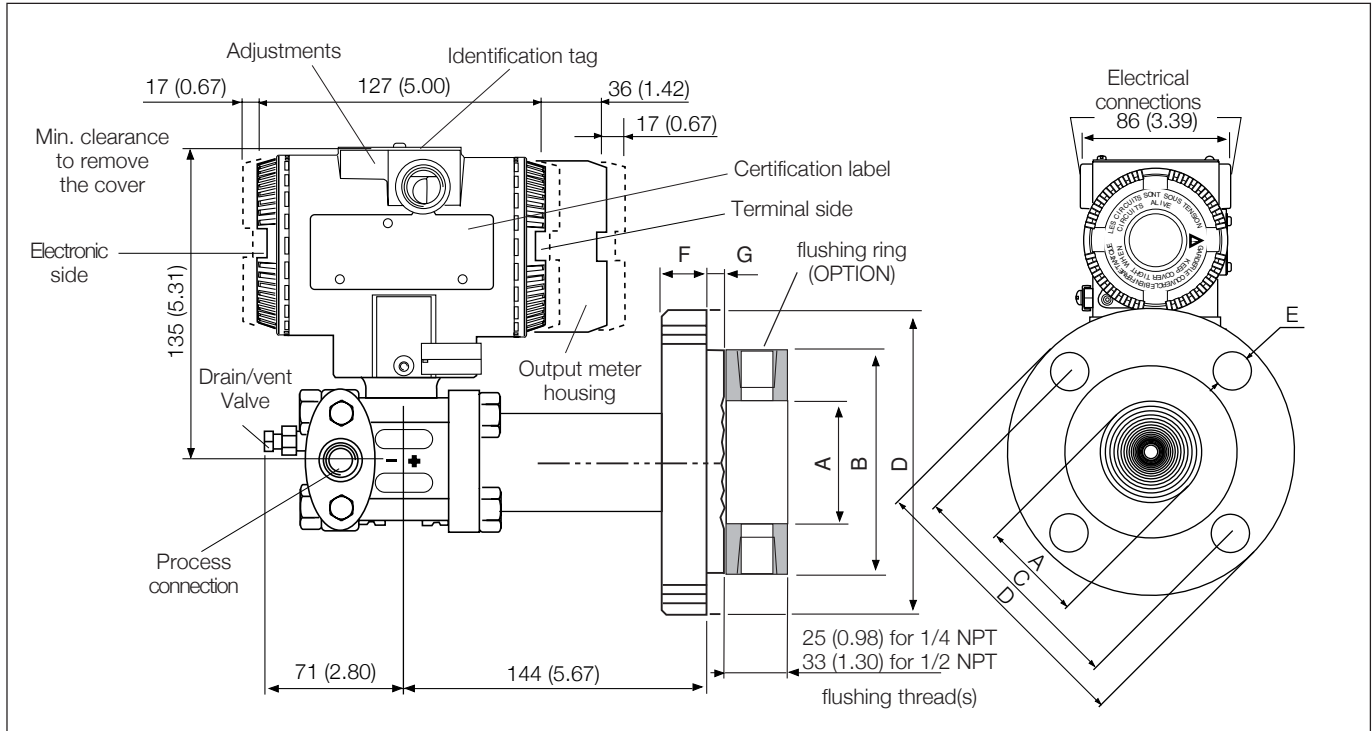

268DD with DIN housing and direct mount seal S264A/S264E flanged Raised Face extended diaphragm

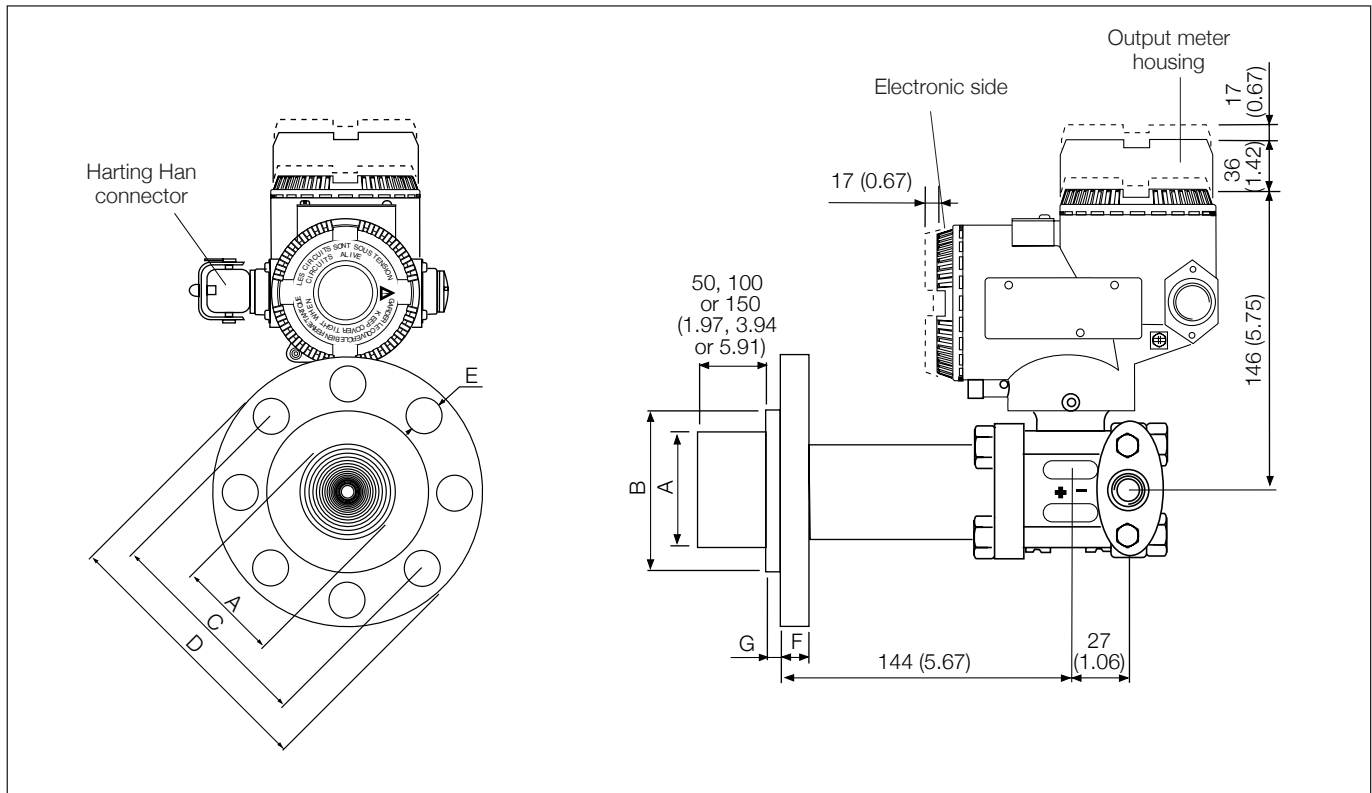

268HD/268ND with barrel housing and direct mount seal S264A/S264E flanged Raised Face extended diaphragm

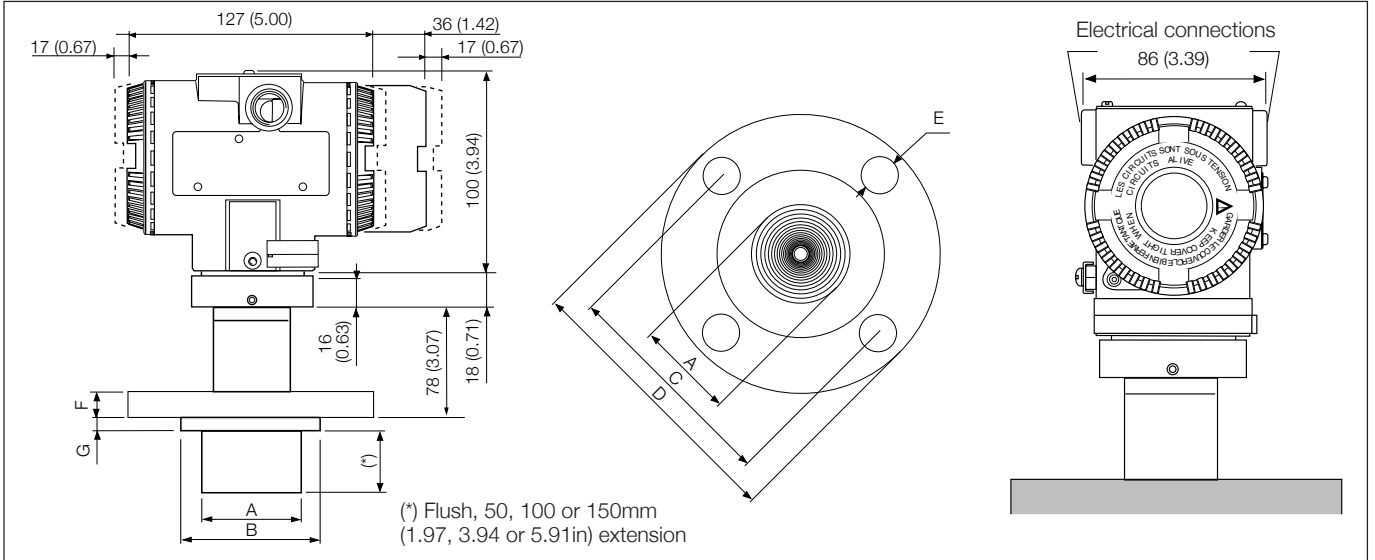

Size/Rating	Dimensions mm (in)									N° of holes
	A (dia)			B (dia)	C (dia)	D (dia)	E (dia)	F	G	
	extended diaphragm	flush diaphragm	flushing ring internal dia							
2in ASME CL 150	48 (1.9)	60 (2.36)	62 (2.44)	92 (3.62)	120.65 (4.75)	152.4 (6)	20 (0.79)	19.05 (0.75)	9.5 (0.37)	4
2in ASME CL 300	48 (1.9)	60 (2.36)	62 (2.44)	92 (3.62)	127 (5)	165.1 (6.5)	20 (0.79)	22.35 (0.88)	9.5 (0.37)	8
2in ASME CL 600	NA	60 (2.36)	62 (2.44)	92 (3.62)	127 (5)	165.1 (6.5)	20 (0.79)	25.4 (1)	9.5 (0.37)	8
2in ASME CL 900	NA	60 (2.36)	62 (2.44)	92 (3.62)	165 (6.5)	215.9 (8.5)	26 (1.02)	38.1 (1.5)	9.5 (0.37)	8
2in ASME CL 1500	NA	60 (2.36)	62 (2.44)	92 (3.62)	165 (6.5)	215.9 (8.5)	26 (1.02)	38.1 (1.5)	9.5 (0.37)	8
3in ASME CL 150	72 (2.83)	89 (3.5)	92 (3.62)	127 (5)	152.4 (6)	190.5 (7.5)	20 (0.79)	23.87 (0.94)	9.5 (0.37)	4
3in ASME CL 300	72 (2.83)	89 (3.5)	92 (3.62)	127 (5)	168.15 (6.62)	209.55 (8.25)	22 (0.86)	28.44 (1.12)	9.5 (0.37)	8
3in ASME CL 600	NA	89 (3.5)	92 (3.62)	127 (5)	168.15 (6.62)	209.55 (8.25)	22 (0.86)	31.75 (1.25)	9.5 (0.37)	8
3in ASME CL 900	NA	89 (3.5)	92 (3.62)	127 (5)	190.5 (7.5)	241 (9.48)	26 (1.02)	38.1 (1.50)	9.5 (0.37)	8
3in ASME CL1500	NA	89 (3.5)	92 (3.62)	127 (5)	203.2 (8)	266.7 (10.5)	31.75 (1.25)	47.8 (1.88)	9.5 (0.37)	8
4in ASME CL 150	94 (3.7)	89 (3.5)	92 (3.62)	157.2 (6.2)	190.5 (7.5)	228.6 (9)	20 (0.79)	24 (0.94)	9.5 (0.37)	8
4in ASME CL 300	94 (3.7)	89 (3.5)	92 (3.62)	157.2 (6.2)	200.2 (7.88)	254 (10)	22 (0.86)	32 (1.26)	9.5 (0.37)	8

Size/Rating	Dimensions mm (in)									N° of holes
	A (dia)			B (dia)	C (dia)	D (dia)	E (dia)	F	G	
	extended diaphragm	flush diaphragm	flushing ring internal dia							
DN50 EN PN16	48 (1.9)	60 (2.36)	62 (2.44)	102 (4.02)	125 (4.92)	165 (6.5)	18 (0.71)	20 (0.79)	9.5 (0.37)	4
DN50 EN PN40	48 (1.9)	60 (2.36)	62 (2.44)	102 (4.02)	125 (4.92)	165 (6.5)	18 (0.71)	20 (0.79)	9.5 (0.37)	4
DN50 EN PN63	NA	60 (2.36)	62 (2.44)	102 (4.02)	135 (5.31)	180 (7.08)	22 (0.86)	26 (1.02)	9.5 (0.37)	4
DN50 EN PN100	NA	60 (2.36)	62 (2.44)	102 (4.02)	145 (5.71)	195 (7.67)	26 (1.02)	28 (1.1)	9.5 (0.37)	4
DN80 EN PN16	72 (2.83)	89 (3.5)	92 (3.62)	138 (5.43)	160 (6.3)	200 (7.87)	18 (0.71)	20 (0.79)	9.5 (0.37)	8
DN80 EN PN40	72 (2.83)	89 (3.5)	92 (3.62)	138 (5.43)	160 (6.3)	200 (7.87)	18 (0.71)	24 (0.94)	9.5 (0.37)	8
DN80 EN PN63	NA	89 (3.5)	92 (3.62)	138 (5.43)	170 (6.7)	215 (8.46)	22 (0.86)	28 (1.1)	9.5 (0.37)	8
DN80 EN PN100	NA	89 (3.5)	92 (3.62)	138 (5.43)	180 (7.08)	230 (9.05)	26 (1.02)	32 (1.26)	9.5 (0.37)	8
DN100 EN PN16	94 (3.7)	89 (3.5)	92 (3.62)	158 (6.22)	180 (7.08)	220 (8.66)	18 (0.71)	20 (0.79)	9.5 (0.37)	8
DN100 EN PN40	94 (3.7)	89 (3.5)	92 (3.62)	162 (6.38)	190 (7.48)	235 (9.25)	22 (0.86)	24 (0.94)	9.5 (0.37)	8

Size/Rating	Dimensions mm (in)							N° of holes
	A (dia) flush diaphragm	B (dia)	C (dia)	D (dia)	E (dia)	F	G	
A50 Class 10K	60 (2.36)	96 (3.78)	120 (4.72)	155 (6.1)	15 (0.59)	16 (0.63)	9.5 (0.37)	4
A50 Class 20K	60 (2.36)	96 (3.78)	120 (4.72)	155 (6.1)	19 (0.75)	18 (0.71)	9.5 (0.37)	4
A50 Class 40K	60 (2.36)	104.3 (4.11)	130 (5.12)	165 (6.5)	19 (0.75)	26 (1.02)	9.5 (0.37)	8
A80 Class 10K	89 (3.5)	126 (4.96)	150 (5.91)	185 (7.28)	15 (0.59)	18 (0.71)	9.5 (0.37)	8
A80 Class 20K	89 (3.5)	132 (5.2)	160 (6.3)	200 (7.87)	23 (0.91)	22 (0.87)	9.5 (0.37)	8
A80 Class 40K	89 (3.5)	139.4 (5.49)	170 (6.69)	210 (8.27)	23 (0.91)	32 (1.26)	9.5 (0.37)	8
A100 Class 10K	89 (3.5)	151 (5.94)	175 (6.89)	210 (8.27)	19 (0.75)	18 (0.71)	9.5 (0.37)	8
A100 Class 20K	89 (3.5)	160 (6.3)	185 (7.28)	225 (8.86)	23 (0.91)	24 (0.94)	9.5 (0.37)	8

268DD with barrel housing and direct mount seal S264R flanged Ring Joint flush diaphragm

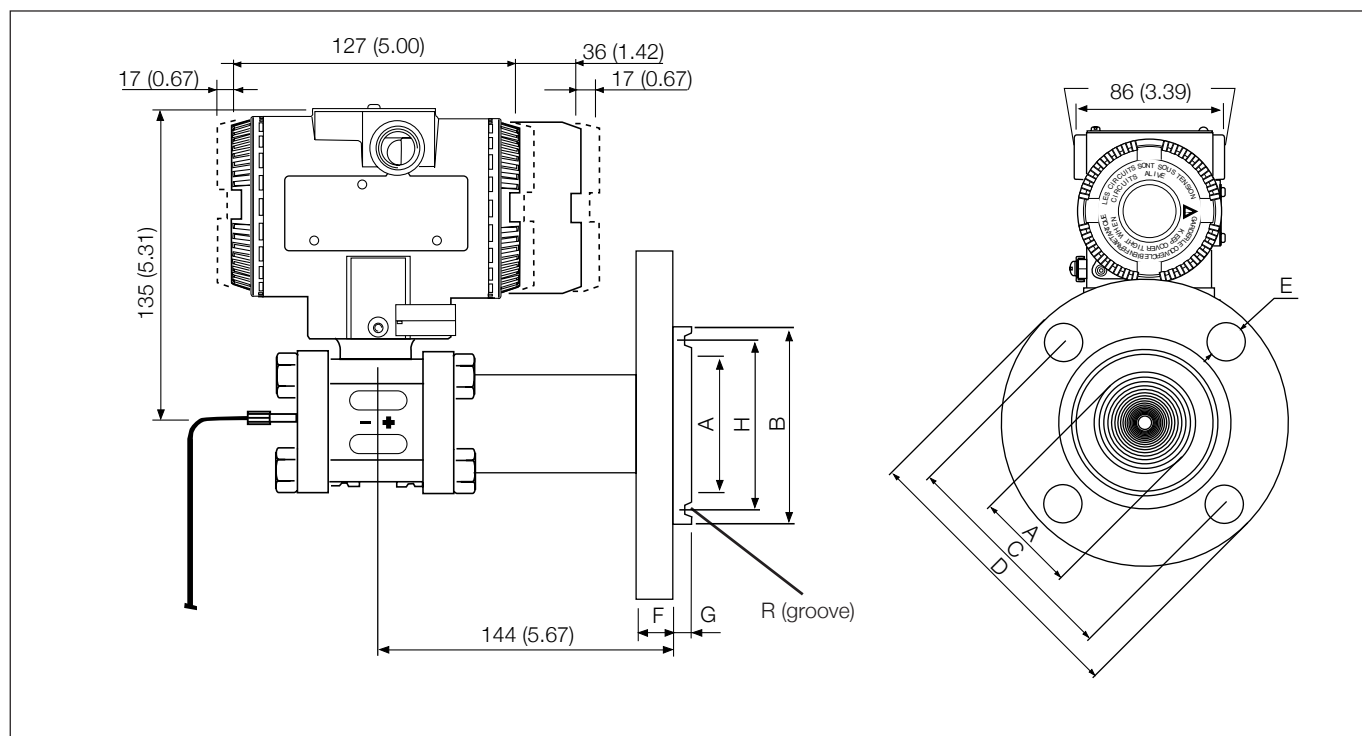

Size/Rating	Dimensions mm (in)								R	N° of holes
	A (dia)	B (dia)	C (dia)	D (dia)	E (dia)	F	G	H (dia)		
1-1/2in ASME CL 150	48 (1.89)	83 (3.27)	98.6 (3.88)	127 (5)	15.75 (0.62)	17.5 (0.69)	17.3 (0.68)	65.1 (2.56)	R19	4
1-1/2in ASME CL 300	48 (1.89)	90 (3.54)	114.3 (4.5)	155.5 (6.12)	22.35 (0.88)	20.6 (0.81)	17.3 (0.68)	68.3 (2.69)	R20	4
1-1/2in ASME CL 600	48 (1.89)	90 (3.54)	114.3 (4.5)	155.5 (6.12)	22.35 (0.88)	22.4 (0.88)	17.3 (0.68)	68.3 (2.69)	R20	4
1-1/2in ASME CL 900/1500	48 (1.89)	92 (3.62)	124 (4.88)	177.8 (7)	28.45 (1.12)	31.8 (1.25)	20.8 (0.82)	68.3 (2.69)	R20	4
2in ASME CL 150	60 (2.36)	102 (4.02)	120.65 (4.75)	152.4 (6)	19.05 (0.75)	19.05 (0.75)	17.3 (0.68)	82.6 (3.25)	R22	4
2in ASME CL 300	60 (2.36)	108 (4.25)	127 (5)	165.1 (6.5)	19.05 (0.75)	22.35 (0.88)	17.3 (0.68)	82.6 (3.25)	R23	8
2in ASME CL 600	60 (2.36)	108 (4.25)	127 (5)	165.1 (6.5)	19.05 (0.75)	25.4 (1)	17.3 (0.68)	82.6 (3.25)	R23	8
2in ASME CL 900/1500	60 (2.36)	124 (4.88)	165 (6.5)	215.9 (8.5)	25.4 (1)	38.1 (1.5)	20.8 (0.82)	95.3 (3.75)	R24	8
3in ASME CL 150	89 (3.5)	133 (5.24)	152.4 (6)	190.5 (7.5)	19.05 (0.75)	23.87 (0.94)	17.3 (0.68)	114.3 (4.5)	R29	4
3in ASME CL 300	89 (3.5)	146 (5.75)	168.15 (6.62)	209.55 (8.25)	22.35 (0.88)	28.44 (1.12)	17.3 (0.68)	123.8 (4.87)	R31	8
3in ASME CL 600	89 (3.5)	146 (5.75)	168.15 (6.62)	209.55 (8.25)	22.35 (0.88)	31.75 (1.25)	17.3 (0.68)	123.8 (4.87)	R31	8
3in ASME CL 900	89 (3.5)	155 (6.10)	190.5 (7.5)	241.3 (9.5)	25.4 (1)	38.1 (1.50)	20.8 (0.82)	123.8 (4.87)	R31	8
3in ASME CL 1500	89 (3.5)	168 (6.61)	203.2 (8)	266.7 (10.5)	31.75 (1.25)	47.8 (1.88)	20.8 (0.82)	136.5 (5.37)	R35	8

268DD with barrel housing and direct mount seal S264M off-line flanged

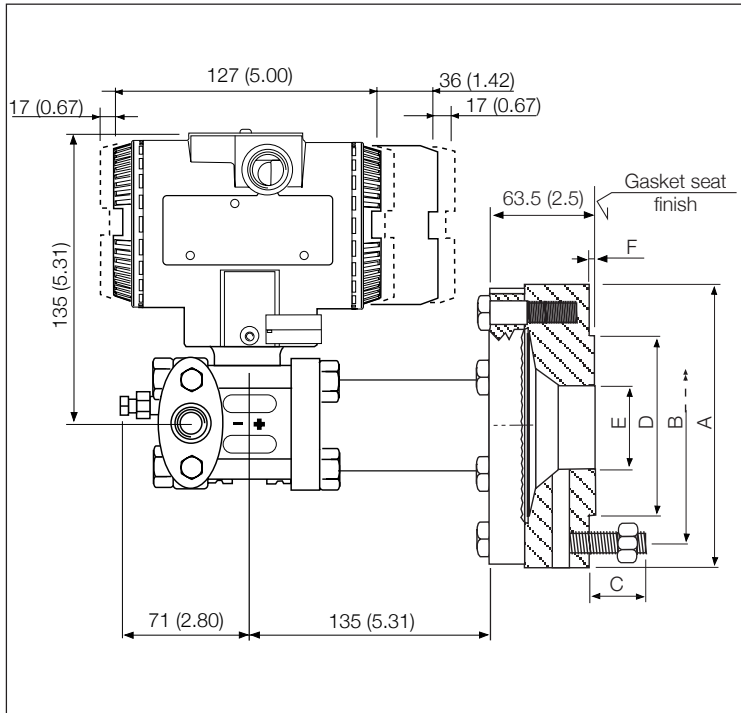

268HD/268ND with barrel housing and direct mount seal S264M off-line flanged

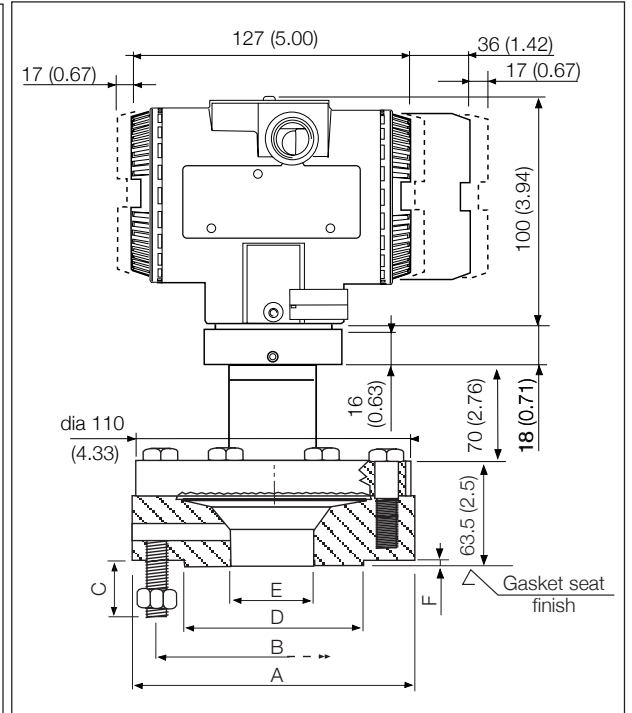

Connection		Dimensions mm (in)						
Size	Standard	A (dia)	B (dia)	C (4 studs)		D (dia)	E (dia)	F
				Length	Thread			
1/2in	ASME CL 150	110 (4.33)	60.5 (2.38)	39 (1.53)	1/2in - 13 UNC	35.1 (1.38)	15.8 (0.62)	1.6 (0.06)
	ASME CL 300	110 (4.33)	66.5 (2.62)	39 (1.53)	1/2in - 13 UNC			
1in	ASME CL 150	110 (4.33)	79.4 (3.12)	39 (1.53)	1/2in - 13 UNC	50.8 (2)	26.7 (1.05)	1.6 (0.06)
	ASME CL 300	124 (4.88)	88.9 (3.5)	51 (2)	5/8in - 11 UNC			
1 1/2in	ASME CL 150	127 (5)	98.4 (3.87)	39 (1.53)	1/2in - 13 UNC	73 (2.87)	41 (1.61)	1.6 (0.06)
	ASME CL 300	155 (6.1)	114.3 (4.5)	57 (2.24)	3/4in - 10 UNC			
DN 25	EN PN 16-40	115 (4.52)	85 (3.34)	42 (1.65)	M12	68 (2.67)	28.5 (1.12)	2 (0.07)
DN 40	EN PN 16-40	150 (5.9)	110 (4.33)	48 (1.89)	M16	88 (3.46)	43.1 (1.69)	3 (0.12)

Wafer remote seal mod. S264W

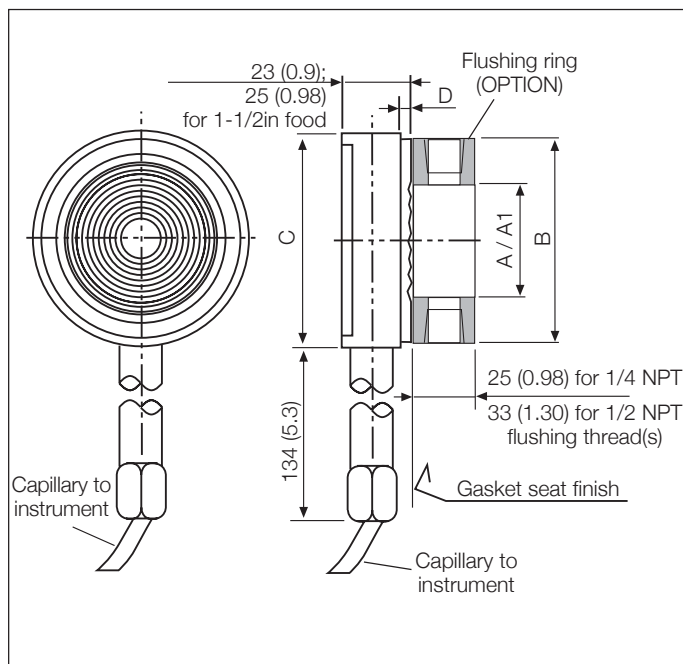

Size	DIMENSIONS mm (in)				
	A (dia) diaph.	A1 Flushing ring int. dia.	B (dia)	C	D
1 1/2in	50 (1.97)	52 (2.05)	73 (2.87)	76.8 (3.02)	1.6 (0.06)
2in	60 (2.36)	62 (2.44)	92 (3.62)	95.8 (3.77)	
3in	89 (3.5)	92 (3.62)	127 (5)	130.8 (5.15)	
DN 40	50 (1.97)	52 (2.05)	88 (3.46)	92 (3.62)	3 (0.12)
DN 50	60 (2.36)	62 (2.44)	102 (4.02)	106 (4.17)	
DN 80	89 (3.5)	92 (3.62)	138 (5.43)	142 (5.59)	
1 1/2in (food)	50 (1.97)	52 (2.05)	73 (2.87)	76.8 (3.02)	N.A.
3in (food)	89 (3.5)	92 (3.62)	127 (5)	130.8 (5.15)	3.7 (0.15)

268DD with barrel housing and direct mount seal S264T off-line threaded

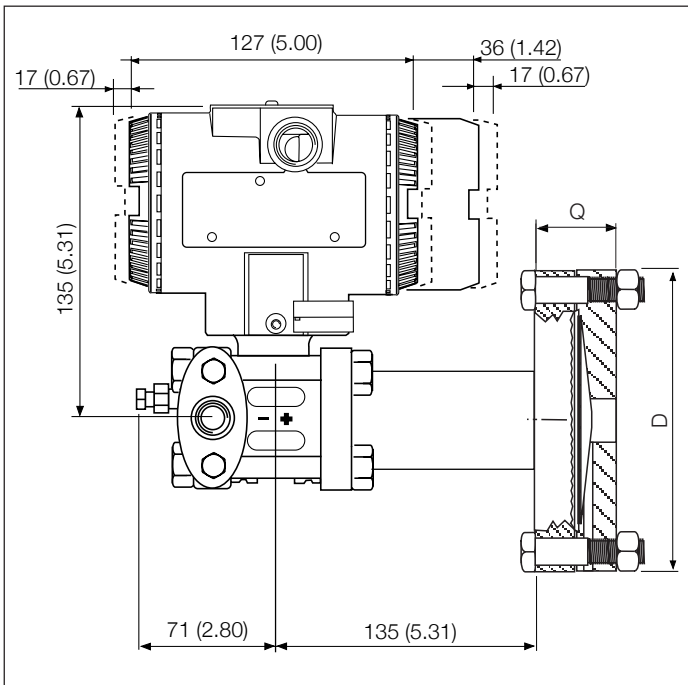

268HD/268ND with barrel housing and direct mount seal S264T off-line threaded

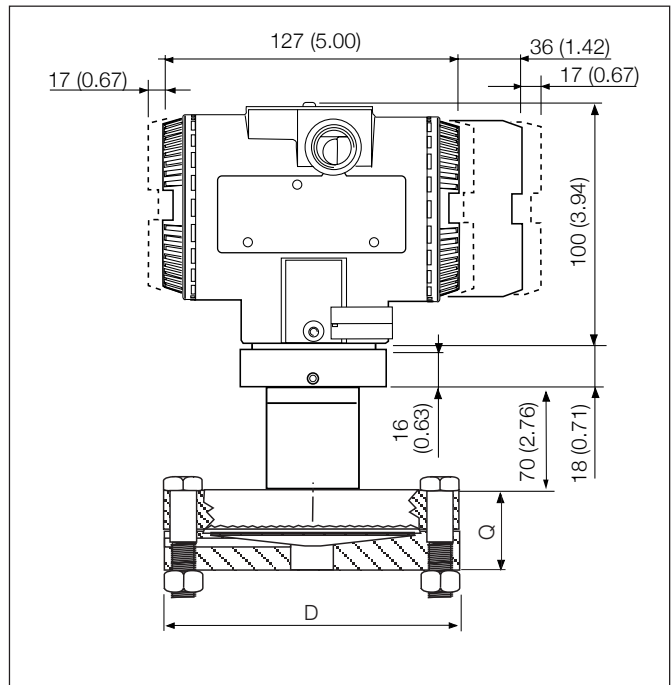

Size	Dimensions mm (in)	
	D (dia)	Q
1/4in NPT, 1/2in NPT	109.2 (4.3)	53.3 (2.1)
3/4in NPT, 1in NPT, 1 1/2in NPT	109.2 (4.3)	63.5 (2.5)

Electrical connections

HART Version

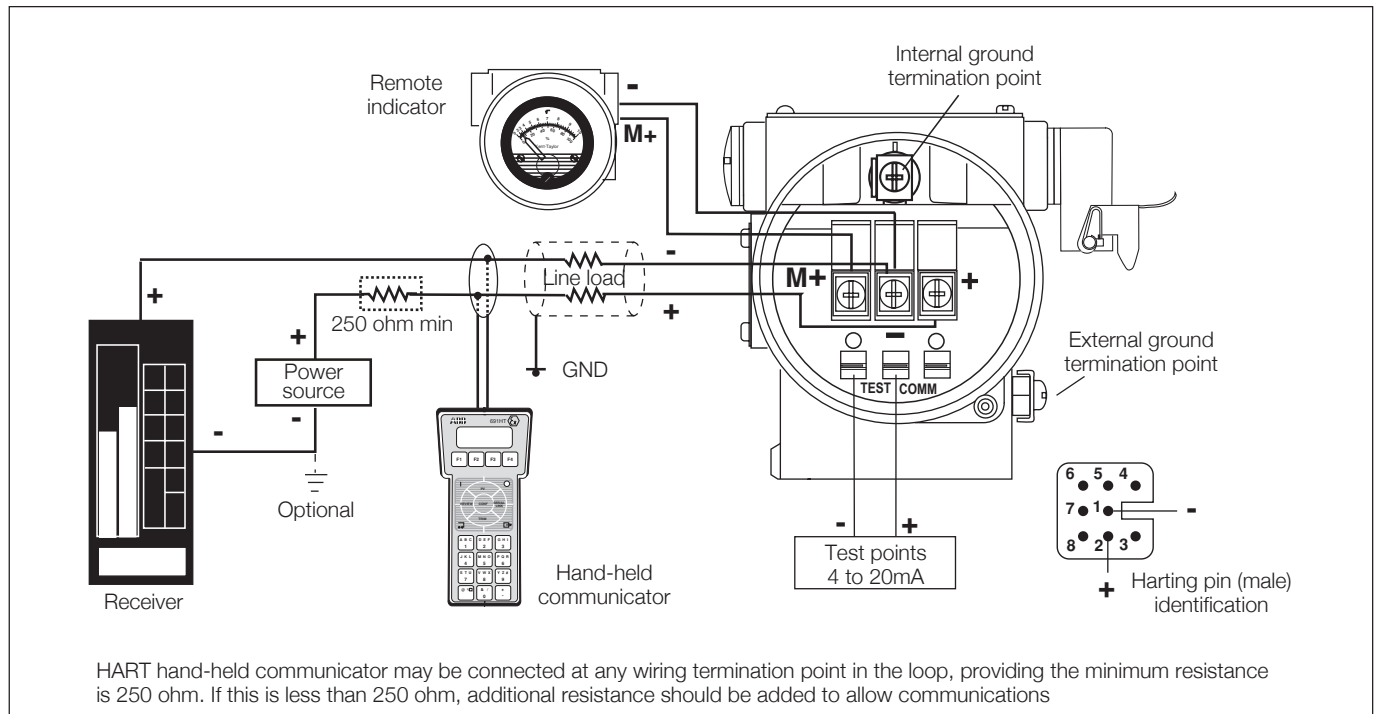

HART hand-held communicator may be connected at any wiring termination point in the loop, providing the minimum resistance is 250 ohm. If this is less than 250 ohm, additional resistance should be added to allow communications

BASIC ORDERING INFORMATION model 268DD Safety Differential Pressure Transmitter with direct mount seal

Select one character or set of characters from each category and specify complete catalog number.
 Refer to additional ordering information code and specify one or more codes for each transmitter if additional options are required.

BASE MODEL – 1 st to 5 th characters				2	6	8	D	D	X	S	X	X	X	X	X	
Safety Differential Pressure Transmitter with direct mount seal(s) – BASE ACCURACY 0.075%																
SENSOR - Span limits – 6th character																
0.54 and 16kPa	5.4 and 160mbar	2.16 and 64inH ₂ O								E						
0.67 and 40kPa	6.7 and 400mbar	2.67 and 160inH ₂ O								F						
1.1 and 65kPa	11 and 650mbar	4.35 and 260inH ₂ O								G						
2.67 and 160kPa	26.7 and 1600mbar	10.7 and 642inH ₂ O								H						
10 and 600kPa	0.1 and 6bar	1.45 and 87psi								M						
40 and 2400kPa	0.4 and 24bar	5.8 and 348psi								P						
134 and 8000kPa	1.34 and 80bar	19.4 and 1160psi								Q						
267 and 16000kPa	2.67 and 160bar	38.7 and 2320psi								S						
Use code – 7th character											S					
Diaphragm material / Fill fluid (wetted parts) – 8th character																
AISI 316 L ss		Silicone oil	(one seal to be quoted separately)								S					
Hastelloy C276™ (on AISI seat)		Silicone oil	(one seal to be quoted separately)							NACE	H					
Hastelloy C276™		Silicone oil	(one seal to be quoted separately)							NACE	K					
Monel 400™		Silicone oil	(one seal to be quoted separately)							NACE	M					
Tantalum		Silicone oil	(one seal to be quoted separately)							NACE	T					
AISI 316 L ss		Inert fluid-Galden	(one seal to be quoted separately)			(Note 1)					A					
Hastelloy C276™ (on AISI seat)		Inert fluid-Galden	(one seal to be quoted separately)			(Note 1)				NACE	B					
Hastelloy C276™		Inert fluid-Galden	(one seal to be quoted separately)			(Note 1)				NACE	F					
Monel 400™		Inert fluid-Galden	(one seal to be quoted separately)			(Note 1)				NACE	C					
Tantalum		Inert fluid-Galden	(one seal to be quoted separately)			(Note 1)				NACE	D					
AISI 316 L ss		Inert fluid-Halocarbon	(one seal to be quoted separately)			(Note 1)					L					
Hastelloy C276™ (on AISI seat)		Inert fluid-Halocarbon	(one seal to be quoted separately)			(Note 1)				NACE	Q					
Hastelloy C276™		Inert fluid-Halocarbon	(one seal to be quoted separately)			(Note 1)				NACE	P					
Monel 400™		Inert fluid-Halocarbon	(one seal to be quoted separately)			(Note 1)				NACE	4					
Tantalum		Inert fluid-Halocarbon	(one seal to be quoted separately)			(Note 1)				NACE	5					
AISI 316 L ss		Silicone oil	(two seals to be quoted separately)								R					
AISI 316 L ss		Inert fluid-Galden	(two seals to be quoted separately)			(Note 1)					2					
AISI 316 L ss		Inert fluid-Halocarbon	(two seals to be quoted separately)			(Note 1)					W					
Process flanges/adapters material and connection (wetted parts) – 9th character																
AISI 316 L ss for two seals construction						(Note 2)				NACE		R				
AISI 316 L ss (Horizontal connection)		1/4 – 18 NPT-f direct (7/16 – 20 UNF U.S. drilling)				(Note 3)				NACE		A				
AISI 316 L ss (Horizontal connection)		1/2 – 14 NPT-f through adapter (7/16 – 20 UNF U.S. drilling)				(Note 3)				NACE		B				
Hastelloy C276™ (Horizontal connection)		1/4 – 18 NPT-f direct (7/16 – 20 UNF U.S. drilling)				(Notes 3, 4)				NACE		D				
Hastelloy C276™ (Horizontal connection)		1/2 – 14 NPT-f through adapter (7/16 – 20 UNF U.S. drilling)				(Notes 3, 4)				NACE		E				
Monel 400™ (Horizontal connection)		1/4 – 18 NPT-f direct (7/16 – 20 UNF U.S. drilling)				(Notes 3, 4)				NACE		G				
Monel 400™ (Horizontal connection)		1/2 – 14 NPT-f through adapter (7/16 – 20 UNF U.S. drilling)				(Notes 3, 4)				NACE		H				
Bolts/Gasket (wetted parts) – 10th character																
AISI 316 ss (NACE) without gaskets for two seals construction - (MWP = 16MPa)			(Note 2)							NACE			R			
AISI 316 ss without gaskets for two seals construction			(Note 2)										S			
AISI 316 ss		Viton™	(Note 3)											1		
AISI 316 ss		PTFE	(Notes 1, 3)											2		
AISI 316 ss (NACE) - (MWP = 16MPa)		Viton™	(Note 3)							NACE				3		
AISI 316 ss (NACE) - (MWP = 16MPa)		PTFE	(Notes 1, 3)							NACE				4		
Housing material and electrical connection – 11th character																
Aluminium alloy (Barrel version)		1/2 – 14 NPT														A
Aluminium alloy (Barrel version)		M20 x 1.5 (CM 20)														B
Aluminium alloy (Barrel version)		Pg 13.5														D
Aluminium alloy (Barrel version)		1/2 GK														C
Aluminium alloy (Barrel version)		Harting Han connector	(general purpose only)			(Note 5)										E
Aluminium alloy copper-free (Barrel version)		1/2 – 14 NPT														H
Aluminium alloy copper-free (Barrel version)		M20 x 1.5 (CM 20)														L
Aluminium alloy copper-free (Barrel version)		Pg 13.5														N
Aluminium alloy copper-free (Barrel version)		1/2 GK														M
Aluminium alloy copper-free (Barrel version)		Harting Han connector	(general purpose only)			(Note 5)										P
AISI 316 L ss (Barrel version)		1/2 – 14 NPT														S
AISI 316 L ss (Barrel version)		M20 x 1.5 (CM 20)														T
AISI 316 L ss (Barrel version)		Pg 13.5														V
AISI 316 L ss (Barrel version)		1/2 GK														U
Aluminium alloy (DIN version)		M20 x 1.5 (CM 20)	(general purpose only)													J
Aluminium alloy (DIN version)		Pg 13.5	(general purpose only)													Y
Aluminium alloy (DIN version)		Harting Han connector	(general purpose only)			(Note 5)										K
Output/Additional options – 12th character																
HART digital communication and 4 to 20mA (SIL2)		No additional options				(Note 6)										T
HART digital communication and 4 to 20mA (SIL2)		Options requested (to be ordered by "Additional ordering code)														8

ADDITIONAL ORDERING INFORMATION for model 268DD

Add one or more 2-digit code(s) after the basic ordering information to select all required options

	XX	XX	XX	XX	XX	XX	XX	XX	XX	XX	XX
Drain/vent valve (material and position) (wetted parts)											
AISI 316 L ss on process axis (Note 7) NACE V1											
AISI 316 L ss on flange side top (Note 7) NACE V2											
AISI 316 L ss on flange side bottom (Note 7) NACE V3											
Hastelloy C276™ on process axis (Note 8) NACE V4											
Hastelloy C276™ on flange side top (Note 8) NACE V5											
Hastelloy C276™ on flange side bottom (Note 8) NACE V6											
Monel 400™ on process axis (Note 9) NACE V7											
Monel 400™ on flange side top (Note 9) NACE V8											
Monel 400™ on flange side bottom (Note 9) NACE V9											
Electrical certification											
ATEX Group II Category 1G and 1/2G, Category 1D and 1/2D - Intrinsic Safety Ex ia											E1
ATEX Group II Category 1/2 GD – Explosion Proof Ex d											E2
Canadian Standard Association (CSA) (only 1/2–14NPT, M20 and Pg 13.5 electrical connection)											E4
Factory Mutual (FM) approval (only with 1/2–14NPT, M20 and Pg 13.5 electrical connection)											E6
GOST (Russia) EEx ia											W1
GOST (Russia) EEx d											W2
GOST (Kazakistan) EEx ia											W3
GOST (Kazakistan) EEx d											W4
Inmetro (Brazil) EEx ia (pending)											W5
Inmetro (Brazil) EEx d (pending)											W6
Inmetro (Brazil) EEx nL (pending)											W7
Metrologic (Russia)											WD
Output meter											
ProMeter, Standard calibration											D1
ProMeter, Special calibration											D2
Analog output indicator linear 0–100% scale											D3
Analog output indicator square root 0–10 scale											D4
Analog output indicator, special graduation (to be specified for linear scale)											D5
Analog output indicator, special graduation (to be specified for square root scale)											D6
Programmable signal meter and HART configurator (CoMeter)											D7
Programmable signal meter and HART configurator (CoMeter – customer configuration)											D8
Surge											
Surge/Transient Protector											S1
Operating manual											
German											M1
Italian											M2
French											M4
Labels & tag language											
German											T1
Italian											T2
Spanish											T3
French											T4
Additional tag plate											
Laser printing of tag on stainless steel plate											I2
Configuration											
Standard – Pressure = inH ₂ O/psi at 20° C; Temperature = deg. F											N2
Standard – Pressure = inH ₂ O/psi at 4° C; Temperature = deg. F											N3
Standard – Pressure = inH ₂ O/psi at 20° C; Temperature = deg. C											N4
Standard – Pressure = inH ₂ O/psi at 4° C; Temperature = deg. C											N5
Custom											N6
Certificates											
Inspection certificate EN 10204–3.1 of calibration (9-point)											C1
Certificate of compliance with the order EN 10204–2.1 of instrument design											C6
Material traceability											
Certificate of compliance with the order EN 10204–2.1 of process wetted parts											H1
Inspection certificate EN 10204–3.1 of process wetted parts											H3
Connector											
Harting Han – straight entry (Note 10)											U3
Harting Han – angle entry (Note 10)											U4

- Note 1: Suitable for oxygen service
- Note 2: Not available with low side diaphragm code S, H, K, M, T, A, B, F, C, D, L, Q, P, 4, 5
- Note 3: Not available with low side diaphragm code R, 2, W
- Note 4: Not available with diaphragm material/fill fluid code S, H, A, B, L, Q
- Note 5: Select type in additional ordering code
- Note 6: Not available with Electronic Housing code P, E, K
- Note 7: Not available with Process flanges/adapters code D, E, G, H, R
- Note 8: Not available with Process flanges/adapters code A, B, G, H, R
- Note 9: Not available with Process flanges/adapters code A, B, D, E, R
- Note 10: Not available with Electronic housing code U, S, T, V, H, M, L, N, D, C, A, B, J, Y

Standard delivery items (can be differently specified by additional ordering code)

- Adapters supplied loose
- Plug on axis (no drain/vent valves)
- General purpose (no electrical certification)
- No meter/display, no mounting bracket, no surge protection
- English manual and labels
- Configuration with kPa and deg. C units
- No test, inspection or material traceability certificates

THE SELECTION OF SUITABLE WETTED PARTS AND FILLING FLUID FOR COMPATIBILITY WITH THE PROCESS MEDIA IS A CUSTOMER'S RESPONSIBILITY, IF NOT OTHERWISE NOTIFIED BEFORE MANUFACTURING.

BASIC ORDERING INFORMATION model 268HD Safety Gauge Pressure Transmitter with direct mount seal

Select one character or set of characters from each category and specify complete catalog number.

Refer to additional ordering information code and specify one or more codes for each transmitter if additional options are required.

BASE MODEL – 1 st to 5 th characters				2	6	8	H	D	X	X	X	X	X
Safety Gauge Pressure Transmitter with direct mount seal – BASE ACCURACY 0.075%													
SENSOR - Span limits – 6th character													
1.1 and 65 kPa	11 and 650mbar	4.35 and 260inH ₂ O										G	
2.67 and 160kPa	26.7 and 1600mbar	10.7 and 642inH ₂ O										H	
10 and 600kPa	0.1 and 6bar	1.45 and 87psi										M	
40 and 2400kPa	0.4 and 24bar	5.8 and 348psi										P	
134 and 8000kPa	1.34 and 80bar	19.4 and 1160psi										Q	
267 and 16000kPa	2.67 and 160bar	38.7 and 2320psi										S	
Diaphragm material / Fill fluid – 7th character													
AISI 316 L ss		Silicone oil										R	
AISI 316 L ss		Inert fluid - Galden		(Note 1)								2	
AISI 316 L ss		Inert fluid - Halocarbon		(Note 1)								W	
Process connection – 8th character													
Direct mount seal		(to be quoted separately)										M	
Housing material and electrical connection – 9th character													
Aluminium alloy (Barrel version)		1/2 – 14 NPT										A	
Aluminium alloy (Barrel version)		M20 x 1.5 (CM 20)										B	
Aluminium alloy (Barrel version)		Pg 13.5										D	
Aluminium alloy (Barrel version)		1/2 GK										C	
Aluminium alloy (Barrel version)		Harting Han connector		(general purpose only)		(Note 2)						E	
Aluminium alloy copper-free (Barrel version)		1/2 – 14 NPT										H	
Aluminium alloy copper-free (Barrel version)		M20 x 1.5 (CM 20)										L	
Aluminium alloy copper-free (Barrel version)		Pg 13.5										N	
Aluminium alloy copper-free (Barrel version)		1/2 GK										M	
Aluminium alloy copper-free (Barrel version)		Harting Han connector		(general purpose only)		(Note 2)						P	
AISI 316 L ss (Barrel version)		1/2 – 14 NPT										S	
AISI 316 L ss (Barrel version)		M20 x 1.5 (CM20)										T	
AISI 316 L ss (Barrel version)		Pg 13.5										V	
AISI 316 L ss (Barrel version)		1/2 GK										U	
Output/Additional options – 10th character													
HART digital communication and 4 to 20mA (SIL 2)		No additional options										(Note 3)	
HART digital communication and 4 to 20mA (SIL 2)		Options requested (to be ordered by "Additional ordering code")										T 8	

ADDITIONAL ORDERING INFORMATION for model 268HD

Add one or more 2-digit code(s) after the basic ordering information to select all required options

	XX	XX	XX	XX	XX	XX	XX	XX	XX	XX
Electrical certification										
ATEX Group II Category 1G and 1/2G, Category 1D and 1/2D - Intrinsic Safety Ex ia	E1									
ATEX Group II Category 1/2 GD – Explosion Proof Ex d	E2									
Canadian Standard Association (CSA) (only 1/2–14NPT, M20 and Pg 13.5 electrical connection)	E4									
Factory Mutual (FM) approval (only with 1/2–14NPT, M20 and Pg 13.5 electrical connection)	E6									
GOST (Russia) EEx ia	W1									
GOST (Russia) EEx d	W2									
GOST (Kazakistan) EEx ia	W3									
GOST (Kazakistan) EEx d	W4									
Inmetro (Brazil) EEx ia (pending)	W5									
Inmetro (Brazil) EEx d (pending)	W6									
Inmetro (Brazil) EEx nL (pending)	W7									
Metrologic (Russia)	WD									
Output meter										
ProMeter, Standard calibration	D1									
ProMeter, Special calibration	D2									
Analog output indicator linear 0–100% scale	D3									
Analog output indicator, special graduation (to be specified for linear scale)	D5									
Programmable signal meter and HART configurator (CoMeter)	D7									
Programmable signal meter and HART configurator (CoMeter – customer configuration)	D8									
Surge										
Surge/Transient Protector									S1	
Operating manual										
German									M1	
Italian									M2	
French									M4	
Labels & tag language										
German									T1	
Italian									T2	
Spanish									T3	
French									T4	
Additional tag plate										
Laser printing of tag on stainless steel plate									I2	
Configuration										
Standard – Pressure = inH ₂ O/psi at 20° C; Temperature = deg. F									N2	
Standard – Pressure = inH ₂ O/psi at 4° C; Temperature = deg. F									N3	
Standard – Pressure = inH ₂ O/psi at 20° C; Temperature = deg.C									N4	
Standard – Pressure = inH ₂ O/psi at 4° C; Temperature = deg. C									N5	
Custom									N6	
Certificates										
Inspection certificate EN 10204–3.1 of calibration (9-point)									C1	
Certificate of compliance with the order EN 10204–2.1 of instrument design									C6	
Material traceability										
Certificate of compliance with the order EN 10204–2.1 of process wetted parts									H1	
Inspection certificate EN 10204–3.1 of process wetted parts									H3	
Connector										
Harting Han – straight entry								(Note 4)		U3
Harting Han – angle entry								(Note 4)		U4

Note 1: Suitable for oxygen service

Note 2: Select type in additional ordering code

Note 3: Not available with Electronic Housing code P, E

Note 4: Not available with Electronic housing code U, S, T, V, H, M, L, N, D, C, A, B

Standard delivery items (can be differently specified by additional ordering code)

- General purpose (no electrical certification)
- No meter/display, no mounting bracket, no surge protection
- English manual and labels
- Configuration with kPa and deg. C units
- No test, inspection or material traceability certificates

THE SELECTION OF SUITABLE WETTED PARTS AND FILLING FLUID FOR COMPATIBILITY WITH THE PROCESS MEDIA IS A CUSTOMER'S RESPONSIBILITY, IF NOT OTHERWISE NOTIFIED BEFORE MANUFACTURING.

BASIC ORDERING INFORMATION model 268ND Safety Absolute Pressure Transmitter with direct mount seal

Select one character or set of characters from each category and specify complete catalog number.

Refer to additional ordering information code and specify one or more codes for each transmitter if additional options are required.

BASE MODEL – 1 st to 5 th characters			2	6	8	N	D	X	X	X	X	X
Safety Absolute Pressure Transmitter with direct mount seal – BASE ACCURACY 0.075%												
SENSOR - Span limits – 6th character												
1.1 and 65 kPa	11 and 650mbar	8 and 480mmHg						G				
2.67 and 160kPa	26.7 and 1600mbar	20 and 1200mmHg						H				
10 and 600kPa	0.1 and 6bar	1.45 and 87psi						M				
40 and 2400kPa	0.4 and 24bar	5.8 and 348psi						P				
134 and 8000kPa	1.34 and 80bar	19.4 and 1160psi						Q				
267 and 16000kPa	2.67 and 160bar	38.7 and 2320psi						S				
Diaphragm material / Fill fluid – 7th character												
AISI 316 L ss		Silicone oil						R				
AISI 316 L ss		Inert fluid - Galden				(Note 1)		2				
AISI 316 L ss		Inert fluid - Halocarbon				(Note 1)		W				
Process connection – 8th character												
Direct mount seal		(to be quoted separately)								M		
Housing material and electrical connection – 9th character												
Aluminium alloy (Barrel version)		1/2 – 14 NPT										A
Aluminium alloy (Barrel version)		M20 x 1.5 (CM 20)										B
Aluminium alloy (Barrel version)		Pg 13.5										D
Aluminium alloy (Barrel version)		1/2 GK										C
Aluminium alloy (Barrel version)		Harting Han connector				(general purpose only)	(Note 2)					E
Aluminium alloy copper-free (Barrel version)		1/2 – 14 NPT										H
Aluminium alloy copper-free (Barrel version)		M20 x 1.5 (CM 20)										L
Aluminium alloy copper-free (Barrel version)		Pg 13.5										N
Aluminium alloy copper-free (Barrel version)		1/2 GK										M
Aluminium alloy copper-free (Barrel version)		Harting Han connector				(general purpose only)	(Note 2)					P
AISI 316 L ss (Barrel version)		1/2 – 14 NPT										S
AISI 316 L ss (Barrel version)		M20 x 1.5 (CM20)										T
AISI 316 L ss (Barrel version)		Pg 13.5										V
AISI 316 L ss (Barrel version)		1/2 GK										U
Output/Additional options – 10th character												
HART digital communication and 4 to 20mA (SIL 2)	No additional options						(Note 3)					T
HART digital communication and 4 to 20mA (SIL 2)	Options requested (to be ordered by "Additional ordering code")											8

ADDITIONAL ORDERING INFORMATION for model 268ND

Add one or more 2-digit code(s) after the basic ordering information to select all required options

	XX	XX	XX	XX	XX	XX	XX	XX	XX	XX
Electrical certification										
ATEX Group II Category 1G and 1/2G, Category 1D and 1/2D - Intrinsic Safety Ex ia	E1									
ATEX Group II Category 1/2 GD – Explosion Proof Ex d	E2									
Canadian Standard Association (CSA) (only 1/2–14NPT, M20 and Pg 13.5 electrical connection)	E4									
Factory Mutual (FM) approval (only with 1/2–14NPT, M20 and Pg 13.5 electrical connection)	E6									
GOST (Russia) EEx ia	W1									
GOST (Russia) EEx d	W2									
GOST (Kazakistan) EEx ia	W3									
GOST (Kazakistan) EEx d	W4									
Inmetro (Brazil) EEx ia (pending)	W5									
Inmetro (Brazil) EEx d (pending)	W6									
Inmetro (Brazil) EEx nL (pending)	W7									
Metrologic (Russia)	WD									
Output meter										
ProMeter, Standard calibration	D1									
ProMeter, Special calibration	D2									
Analog output indicator linear 0–100% scale	D3									
Analog output indicator, special graduation (to be specified for linear scale)	D5									
Programmable signal meter and HART configurator (CoMeter)	D7									
Programmable signal meter and HART configurator (CoMeter – customer configuration)	D8									
Surge										
Surge/Transient Protector									S1	
Operating manual										
German										M1
Italian										M2
French										M4
Labels & tag language										
German										T1
Italian										T2
Spanish										T3
French										T4
Additional tag plate										
Laser printing of tag on stainless steel plate										I2
Configuration										
Standard – Pressure = inH ₂ O/psi at 20° C; Temperature = deg. F										N2
Standard – Pressure = inH ₂ O/psi at 4° C; Temperature = deg. F										N3
Standard – Pressure = inH ₂ O/psi at 20° C; Temperature = deg.C										N4
Standard – Pressure = inH ₂ O/psi at 4° C; Temperature = deg. C										N5
Custom										N6
Certificates										
Inspection certificate EN 10204–3.1 of calibration (9-point)										C1
Certificate of compliance with the order EN 10204–2.1 of instrument design										C6
Material traceability										
Certificate of compliance with the order EN 10204–2.1 of process wetted parts										H1
Inspection certificate EN 10204–3.1 of process wetted parts										H3
Connector										
Harting Han – straight entry									(Note 4)	U3
Harting Han – angle entry									(Note 4)	U4

Note 1: Suitable for oxygen service

Note 2: Select type in additional ordering code

Note 3: Not available with Electronic Housing code P, E

Note 4: Not available with Electronic housing code U, S, T, V, H, M, L, N, D, C, A, B

Standard delivery items (can be differently specified by additional ordering code)

- General purpose (no electrical certification)
- No meter/display, no mounting bracket, no surge protection
- English manual and labels
- Configuration with kPa and deg. C units
- No test, inspection or material traceability certificates

THE SELECTION OF SUITABLE WETTED PARTS AND FILLING FLUID FOR COMPATIBILITY WITH THE PROCESS MEDIA IS A CUSTOMER'S RESPONSIBILITY, IF NOT OTHERWISE NOTIFIED BEFORE MANUFACTURING.

BASIC ORDERING INFORMATION model S264A Flanged seal (flush and extended) - Raised Face

Select one character or set of characters from each category and specify complete catalog number.

BASE MODEL – 1 st to 5 th characters	S	2	6	4	A	X	X	X	X	X	X	X	X	X	X	Cont'd
Flanged seal (flush and extended) to ASME B16.5																
Transmitter side of connection – 6th character																
High side																
Low side																
Mounting flange – 7th character																
Rotating																
Size – 8th character																
2in																
3in																
4in																
Rating – 9th character																
ASME CL 150																1
ASME CL 300																2
ASME CL 600 (Not available with 4in size)																3
ASME CL 900 (Not available with 4in size)																4
ASME CL 1500 (Not available with 4in size)																5
Mounting flange material – 10th character																
Carbon steel																A
AISI 316 ss																B
Extensions length and material – 11th character																
Flush (see next for diaphragm material)																F
50mm (2in) AISI 316 L ss (Note 2)																1
50mm (2in) Hastelloy 276™ (Note 2)																2
100mm (4in) AISI 316 L ss (Note 2)																3
100mm (4in) Hastelloy 276™ (Note 2)																4
150mm (6in) AISI 316 L ss (Note 2)																5
150mm (6in) Hastelloy 276™ (Note 2)																6
Diaphragm material (seal) – 12th character																
AISI 316 L ss (Note 3)																NACE S
Hastelloy C276™																NACE H
Hastelloy C2000™ - (not for extended diaphragm)																NACE M
Inconel 625 - (not for extended diaphragm)																NACE L
Tantalum - (not for extended diaphragm)																T
AISI 316 L ss gold plated - (not for extended diaphragm)																NACE N
AISI 316 L ss with anti-stick coating																NACE K
Hastelloy C276™ with anti-stick coating																NACE Y
AISI 316 L ss with anti-corrosion and anti-stick coating																NACE W
Diaflex (AISI with Anti Abrasion treatment)																F
Superduplex ss (UNS S32750 to ASTM SA479) - (not for extended diaphragm)																E
Seal surface finish – 13th character																
Serrated (Notes 3, 5)																1
Smooth																2
Capillary protection – 14th character																
AISI 316 L ss armour																A
AISI 316 L ss armour with PVC protective cover																B
Extension tube for direct mount seal																N
Capillary length m (feet) – 15th character																
Internal short for direct mount construction																(Note 6) 1
1 (3)																(Note 7) A
1.5 (5)																(Note 7) B
2 (7)																(Note 7) C
2.5 (8)																(Note 7) D
3 (10)																(Note 7) E
3.5 (12)																(Note 7) F
4 (13)																(Note 7) G
4.5 (15)																(Note 7) H
5 (17)																(Note 7) J
5.5 (18)																(Note 7) K
6 (20)																(Note 7) L
6.5 (22)																(Note 7) M
7 (23)																(Note 7) N
7.5 (25)																(Note 7) P
8 (27)																(Note 7) Q
9 (30)																(Note 7) R
10 (33)																(Note 7) S
12 (40)																(Note 7) T
14 (47)																(Note 7) U
16 (53)																(Note 7) V

2600T Pressure Transmitters

Model 268DD, 268HD, 268ND

SS/268XD_6

BASIC ORDERING INFORMATION S264A			X	X	X	X	X
Fill fluid – 16 th character							
Silicone oil			S				
Inert fluid - Galden	(Note 8)		N				
Inert fluid - Halocarbon	(Note 8)		D				
Silicone oil for high temperature			G				
Silicone polymer for low temperature			C				
Mineral oil (FDA approved)	(Note 9)		W				
Vegetable oil (FDA approved)	(Note 9)		A				
Glycerin-water (FDA approved)	(Note 9)		B				
Certification – 17 th character							
None					1		
Flushing ring: hole and thread – 18 th character							
None						N	
1 hole - 1/2in NPT	(Note 4)					2	
2 holes - 1/2in NPT	(Note 4)					3	
1 hole - 1/4in NPT	(Note 4)					4	
2 holes - 1/4in NPT	(Note 4)					5	
Flushing ring material – 19 th character							
None	(Note 10)						N
AISI 316 L ss	(Note 11)	NACE					A
Hastelloy C276	(Notes 11, 12)	NACE					H
Flushing ring: plug and gasket – 20 th character							
No plug - no gasket							N
No plug - garlock	(Note 11)						A
No plug - PTFE	(Note 11)						B
No plug - graphite	(Note 11)						C
AISI 316 L ss - no gasket	(Notes 11, 13)						D
AISI 316 L ss - garlock	(Notes 11, 13)						E
AISI 316 L ss - PTFE	(Notes 11, 13)						F
AISI 316 L ss - graphite	(Notes 11, 13)						G
Hastelloy C276 - no gasket	(Notes 11, 14)						H
Hastelloy C276 - garlock	(Notes 11, 14)						L
Hastelloy C276 - PTFE	(Notes 11, 14)						M
Hastelloy C276 - graphite	(Notes 11, 14)						P

Note 1: Not available with size code E

Note 2: Not available with mounting flange rating code 3, 4, 5

Note 3: Not available with extensions length and material code 2, 4, 6

Note 4: Not available with extensions length and material code 1, 2, 3, 4, 5, 6

Note 5: Not available with diaphragm material code M, L, T, N, K, Y, W and H when selected with extension length and material code F, 2, 4, 6

Note 6: Not available with capillary protection code A, B

Note 7: Not available with capillary protection code N

Note 8: Suitable for oxygen service

Note 9: Suitable for food application

Note 10: Not available with Flushing ring: hole and thread code 2, 3, 4, 5

Note 11: Not available with Flushing ring: hole and thread code N

Note 12: Not available with Seal surface finish code 1

Note 13: Not available with Hastelloy C276 flushing ring material code H

Note 14: Not available with AISI 316L flushing ring material code A

BASIC ORDERING INFORMATION model S264E Flanged seal (flush and extended)

Select one character or set of characters from each category and specify complete catalog number.

BASE MODEL – 1 st to 5 th characters				S	2	6	4	E	X	X	X	X	X	X	X	X	X	X	Cont'd			
Flanged Remote seal (flush and extended) to EN 1092-1																						
Transmitter side of connection – 6th character																						
High side																						
Low side																						
Mounting flange – 7th character																						
Rotating																						
Size – 8th character																						
DN 50																						
DN 80																						
DN 100																						
Rating – 9th character																						
PN 16																						
PN 40																						
PN 63 (Not for DN 100 size)																						
PN 100 (Not for DN 100 size)																						
Mounting flange material – 10th character																						
Carbon steel																						
AISI 316 ss																						
Extensions length and material – 11th character																						
Flush (see next for diaphragm material)																						
50mm (2in)																						
50mm (2in)																						
100mm (4in)																						
100mm (4in)																						
150mm (6in)																						
150mm (6in)																						
Diaphragm material (seal) – 12th character																						
AISI 316 L ss																						
Hastelloy C276™																						
Hastelloy C2000™ - (not for extended diaphragm)																						
Inconel 625 - (not for extended diaphragm)																						
Tantalum - (not for extended diaphragm)																						
AISI 316 L ss gold plated - (not for extended diaphragm)																						
AISI 316 L ss with anti-stick coating																						
Hastelloy C276™ with anti-stick coating																						
AISI 316 L ss with anti-corrosion and anti-stick coating																						
Diaflex (AISI with Anti Abrasion treatment)																						
Superduplex ss (UNS S32750 to ASTM SA479) - (not for extended diaphragm)																						
Seal surface finish – 13th character																						
Serrated																						
Smooth																						
Capillary protection – 14th character																						
AISI 316 L ss armour																						
AISI 316 L ss armour with PVC protective cover																						
Extension tube for direct mount seal																						
Capillary length m (feet) – 15th character																						
Internal short for direct mount construction																						
1 (3)																						
1.5 (5)																						
2 (7)																						
2.5 (8)																						
3 (10)																						
3.5 (12)																						
4 (13)																						
4.5 (15)																						
5 (17)																						
5.5 (18)																						
6 (20)																						
6.5 (22)																						
7 (23)																						
7.5 (25)																						
8 (27)																						
9 (30)																						
10 (33)																						
12 (40)																						
14 (47)																						
16 (53)																						

2600T Pressure Transmitters

Model 268DD, 268HD, 268ND

SS/268XD_6

BASIC ORDERING INFORMATION S264E				X	X	X	X	X
Fill fluid – 16 th character								
Silicone oil				S				
Inert fluid - Galden	(Note 8)			N				
Inert fluid - Halocarbon	(Note 8)			D				
Silicone oil for high temperature				G				
Silicone polymer for low temperature				C				
Mineral oil (FDA approved)	(Note 9)			W				
Vegetable oil (FDA approved)	(Note 9)			A				
Glycerin-water (FDA approved)	(Note 9)			B				
Certification – 17 th character								
None						1		
Flushing ring: hole and thread – 18 th character								
None							N	
1 hole - 1/2in NPT	(Note 4)						2	
2 holes - 1/2in NPT	(Note 4)						3	
1 hole - 1/4in NPT	(Note 4)						4	
2 holes - 1/4in NPT	(Note 4)						5	
Flushing ring material – 19 th character								
None	(Note 10)							N
AISI 316 L ss	(Note 11)	NACE						A
Hastelloy C276	(Notes 11, 12)	NACE						H
Flushing ring: plug and gasket – 20 th character								
No plug - no gasket								N
No plug - garlock	(Note 11)							A
No plug - PTFE	(Note 11)							B
No plug - graphite	(Note 11)							C
AISI 316 L ss - no gasket	(Notes 11, 13)							D
AISI 316 L ss - garlock	(Notes 11, 13)							E
AISI 316 L ss - PTFE	(Notes 11, 13)							F
AISI 316 L ss - graphite	(Notes 11, 13)							G
Hastelloy C276 - no gasket	(Notes 11, 14)							H
Hastelloy C276 - garlock	(Notes 11, 14)							L
Hastelloy C276 - PTFE	(Notes 11, 14)							M
Hastelloy C276 - graphite	(Notes 11, 14)							P

Note 1: Not available with size code E

Note 2: Not available with mounting flange rating code 3, 4

Note 3: Not available with extensions length and material code 2, 4, 6

Note 4: Not available with extensions length and material code 1, 2, 3, 4, 5, 6

Note 5: Not available with diaphragm material code M, L, T, N, K, Y, W and H when selected with extension length and material code F, 2, 4, 6

Note 6: Not available with capillary protection code A, B

Note 7: Not available with capillary protection code N

Note 8: Suitable for oxygen service

Note 9: Suitable for food application

Note 10: Not available with Flushing ring: hole and thread code 2, 3, 4, 5

Note 11: Not available with Flushing ring: hole and thread code N

Note 12: Not available with Seal surface finish code 1

Note 13: Not available with Hastelloy C276 flushing ring material code H

Note 14: Not available with AISI 316L flushing ring material code A

BASIC ORDERING INFORMATION model S264G Flanged seal (flush) to JIS

Select one character or set of characters from each category and specify complete catalog number.

BASE MODEL – 1 st to 5 th characters	S	2	6	4	G	X	X	X	X	X	X	X	X	X	X	Cont'd
Flanged seal (flush) to JIS																
Transmitter side of connection – 6th character																
High side																
Low side																
Mounting flange – 7th character																
Rotating																
Size – 8th character																
A50																
A80																
A100																
Rating – 9th character																
10K																
20K																
40K																
																(Note 1)
Mounting flange material – 10th character																
Carbon steel																
AISI 316 ss																
Extensions length and material – 11th character																
Flush (see next for diaphragm material)																
Diaphragm material (seal) – 12th character																
AISI 316 L ss																
Hastelloy C276™																
Hastelloy C2000™																
Inconel 625																
Tantalum																
AISI 316 L ss gold plated																
AISI 316 L ss with anti-stick coating																
Hastelloy C276™ with anti-stick coating																
AISI 316 L ss with anti-corrosion and anti-stick coating																
Superduplex ss (UNS S32750 to ASTM SA479)																
Seal surface finish – 13th character																
Serrated																
Smooth																
																(Note 2)
Capillary protection – 14th character																
AISI 316 L ss armour																
AISI 316 L ss armour with PVC protective cover																
Extension tube for direct mount seal																
Capillary length m (feet) – 15th character																
Internal short for direct mount construction																
1 (3)																
1.5 (5)																
2 (7)																
2.5 (8)																
3 (10)																
3.5 (12)																
4 (13)																
4.5 (15)																
5 (17)																
5.5 (18)																
6 (20)																
6.5 (22)																
7 (23)																
7.5 (25)																
8 (27)																
9 (30)																
10 (33)																
12 (40)																
14 (47)																
16 (53)																

BASIC ORDERING INFORMATION S264G	X	X	X	X	X
Fill fluid – 16 th character					
Silicone oil	S				
Inert fluid - Galden (Note 5)	N				
Inert fluid - Halocarbon (Note 5)	D				
Silicone oil for high temperature	G				
Silicone polymer for low temperature	C				
Mineral oil (FDA approved) (Note 6)	W				
Vegetable oil (FDA approved) (Note 6)	A				
Glycerin-water (FDA approved) (Note 6)	B				
Certification – 17 th character					
None		1			
Flushing ring: hole and thread – 18 th character					
None			N		
Flushing ring material – 19 th character					
None				N	
Flushing ring: plug and gasket – 20 th character					
No plug - no gasket					N

- Note 1: Not available with A100 size code D
- Note 2: Not available with diaphragm material code H, M, L, T, N, K, Y, W
- Note 3: Not available with capillary protection code A, B
- Note 4: Not available with capillary protection code N
- Note 5: Suitable for oxygen service
- Note 6: Suitable for food application

BASIC ORDERING INFORMATION model S264R Flanged seal - Ring Joint

Select one character or set of characters from each category and specify complete catalog number.

BASE MODEL – 1 st to 5 th characters	S	2	6	4	R	X	X	X	X	X	X	X	X	X	X	Cont'd
Flanged seal Ring joint to ASME B16.5																
Transmitter side of connection – 6th character																
High side							H									
Low side							L									
Mounting flange – 7th character																
Rotating								R								
Size – 8th character																
1-1/2in											B					
2in											C					
3in											D					
Rating – 9th character																
ASME CL 150															1	
ASME CL 300															2	
ASME CL 600															3	
ASME CL 900															4	
ASME CL 1500															5	
Mounting flange material – 10th character																
Carbon steel													A			
AISI 316 ss													B			
Extensions length and material – 11th character																
Flush (see next for diaphragm material)														F		
Diaphragm material – 12th character																
AISI 316 L ss											NACE				S	
Hastelloy C276™											NACE				H	
Inconel 625											NACE				L	
Seal surface finish – 13th character																
Ring joint															3	
Capillary protection – 14th character																
AISI 316 L ss armour																A
AISI 316 L ss armour with PVC protective cover																B
Extension tube for direct mount seal																N
Capillary length m (feet) – 15th character																
Internal short for direct mount construction																1
1 (3)																A
1.5 (5)																B
2 (7)																C
2.5 (8)																D
3 (10)																E
3.5 (12)																F
4 (13)																G
4.5 (15)																H
5 (17)																J
5.5 (18)																K
6 (20)																L
6.5 (22)																M
7 (23)																N
7.5 (25)																P
8 (27)																Q
9 (30)																R
10 (33)																S
12 (40)																T
14 (47)																U
16 (53)																V

2600T Pressure Transmitters

Model 268DD, 268HD, 268ND

SS/268XD_6

BASIC ORDERING INFORMATION S264R	X	X	X	X	X
Fill fluid – 16 th character					
Silicone oil		S			
Inert fluid - Galden (Note 3)		N			
Inert fluid - Halocarbon (Note 3)		D			
Silicone oil for high temperature		G			
Silicone polymer for low temperature		C			
Mineral oil (FDA approved) (Note 4)		W			
Vegetable oil (FDA approved) (Note 4)		A			
Glycerin-water (FDA approved) (Note 4)		B			
Certification – 17 th character					
None			1		
Flushing ring: hole and thread – 18 th character					
Not fitted				N	
Flushing ring material – 19 th character					
None					N
Flushing ring: plug and gasket – 20 th character					
None					N

Note 1: Not available with capillary protection code A, B

Note 2: Not available with capillary protection code N

Note 3: Suitable for oxygen service

Note 4: Suitable for food application

BASIC ORDERING INFORMATION model S264M Off-line mini-flanged seal

Select one character or set of characters from each category and specify complete catalog number.

BASE MODEL – 1 st to 5 th characters		S	2	6	4	M	X	X	X	X	X	X	X	X	X	X
Off-line mini-flanged seal																
Transmitter side of connection – 6th character																
High side							H									
Low side							L									
Mounting flange– 7th character																
Integral with seal								P								
Size/Mounting flange rating – 8th character																
1/2in	ASME CL 150														6	
1/2in	ASME CL 300														7	
1in	ASME CL 150														A	
1in	ASME CL 300														C	
1 1/2in	ASME CL 150														B	
1 1/2in	ASME CL 300														D	
DN25	EN PN 16/40														M	
DN40	EN PN 16/40														N	
Mounting flange/Seat form (seal) – 9th character																
AISI 316 ss	Form RF (raised face) – serrated finish					(Note 1)		NACE							D	
AISI 316 ss	EN 1092-1 Type B1 – serrated finish					(Note 2)		NACE							L	
Hastelloy C276™	Form RF (raised face) – serrated finish					(Note 1)		NACE							U	
Hastelloy C276™	EN 1092-1 Type B1 – serrated finish					(Note 2)		NACE							V	
Diaphragm material (seal) – 10th character																
AISI 316 L ss								NACE							S	
Hastelloy C276™								NACE							H	
Hastelloy C2000™								NACE							M	
Inconel 625								NACE							L	
Tantalum								NACE							T	
AISI 316 L ss gold plated								NACE							N	
Capillary protection – 11th character																
AISI 316 L ss armour	(RECOMMENDED FOR HIGH TEMPERATURE)														A	
AISI 316 L ss armour with PVC protective cover															B	
Extension tube for direct mount seal															N	
Capillary length m (feet) – 12th character																
Internal short for direct mount construction						(Note 3)									1	
1 (3)						(Note 4)									A	
1.5 (5)						(Note 4)									B	
2 (7)						(Note 4)									C	
2.5 (8)						(Note 4)									D	
3 (10)						(Note 4)									E	
3.5 (12)						(Note 4)									F	
4 (13)						(Note 4)									G	
4.5 (15)						(Note 4)									H	
5 (17)						(Note 4)									J	
5.5 (18)						(Note 4)									K	
6 (20)						(Note 4)									L	
6.5 (22)						(Note 4)									M	
7 (23)						(Note 4)									N	
7.5 (25)						(Note 4)									P	
8 (27)						(Note 4)									Q	
9 (30)						(Note 4)									R	
Fill fluid – 13th character																
Silicone oil																S
Inert fluid - Galden	(Note 5)															N
Inert fluid - Halocarbon	(Note 5)															D
Silicone oil for high temperature																G
Silicone polymer for low temperature																C
Mineral oil (FDA approved)	(Note 6)															W
Vegetable oil (FDA approved)	(Note 6)															A
Glycerin-water (FDA approved)	(Note 6)															B
Flushing connections – 14th character																
Not required																1
Provided																Q
Gasket – 15th character																
PTFE																2
Viton™																3
Graphite																7

Note 1: Not available with size/mounting flange rating code M, N

Note 2: Not available with size/mounting flange rating code A, B, C, D, 6, 7

Note 3: Not available with capillary protection code A, B

Note 4: Not available with capillary protection code N

Note 5: Suitable for oxygen service

Note 6: Suitable for food application

BASIC ORDERING INFORMATION model S264T Off-line threaded seal

Select one character or set of characters from each category and specify complete catalog number.

BASE MODEL – 1 st to 5 th characters	S	2	6	4	T	X	X	X	X	X	X	X	X	X	X	X	X
Off-line threaded seal																	
Transmitter side of connection – 6th character																	
High side																	
Low side																	
Size – 7th character																	
1/4in NPT-f																	
1/2in NPT-f																	
3/4in NPT-f																	
1in NPT-f																	
1-1/2in NPT-f																	
Bolts – 8th character																	
AISI 316 L ss																	
Carbon steel																	
Alloy steel																	
Flange material – 9th character																	
AISI 316 ss																	
Hastelloy C276™																	
Diaphragm material – 10th character																	
AISI 316 L ss																	
Hastelloy C276™																	
Hastelloy C2000™																	
Inconel 625																	
Tantalum																	
AISI 316 L ss gold plated																	
Capillary protection – 11th character																	
AISI 316 L ss armour																	
AISI 316 L ss armour with PVC protective cover																	
Extension tube for direct mount seal																	
Capillary length m (feet) – 12th character																	
Internal short for direct mount construction																	
1 (3)																	
1.5 (5)																	
2 (7)																	
2.5 (8)																	
3 (10)																	
3.5 (12)																	
4 (13)																	
4.5 (15)																	
5 (17)																	
5.5 (18)																	
6 (20)																	
6.5 (22)																	
7 (23)																	
7.5 (25)																	
8 (27)																	
9 (30)																	
Fill fluid – 13th character																	
Silicone oil																	
Inert fluid - Galden (Note 3)																	
Inert fluid - Halocarbon (Note 3)																	
Silicone oil for high temperature																	
Silicone polymer for low temperature																	
Mineral oil (FDA approved) (Note 4)																	
Vegetable oil (FDA approved) (Note 4)																	
Glycerin-water (FDA approved) (Note 4)																	
Flushing connections – 14th character																	
Not required																	
Provided (Note 5)																	
Gasket – 15th character																	
PTFE																	
Viton™																	
Graphite																	

Note 1: Not available with capillary protection code A, B

Note 2: Not available with capillary protection code N

Note 3: Suitable for oxygen service

Note 4: Suitable for food application

Note 5: Not available with size code 4

BASIC ORDERING INFORMATION model S264W Wafer Remote Seal

Select one character or set of characters from each category and specify complete catalog number.

BASE MODEL – 1 st to 5 th characters		S	2	6	4	W	X	X	X	X	F	X	X	X	X	X	Cont'd
Wafer Remote Seal																	
Transmitter side of connection – 6 th character																	
High side							H										
Low side							L										
Centering system – 7 th character																	
Seat on back diameter (suitable for ASME backup flange)								B									
Size – 8 th character																	
1 1/2in ASME									A								
2in ASME									B								
3in ASME									C								
1 1/2in ASME food design									1								
3in ASME food design									2								
EN DN40									D								
EN DN50									E								
EN DN80									F								
Seat finish – 9 th character																	
Serrated finish (suitable for ASME)							(Notes 1, 2)			D							
Smooth finish (suitable for ASME)							(Note 1)			E							
Serrated finish to EN 1092-1 Type B1; up to PN40							(Notes 2, 3)			R							
Serrated finish to EN 1092-1 Type B2; PN63 to PN100							(Notes 2, 3)			S							
Smooth finish (suitable for EN)							(Notes 2, 3)			T							
Use code – 10 th character											F						
Diaphragm material – 11 th character																	
AISI 316 L ss									NACE			S					
Hastelloy C276™							(Notes 2, 4)		NACE			H					
Hastelloy C2000™							(Notes 2, 4)		NACE			M					
Inconel 625							(Notes 2, 4)		NACE			L					
Tantalum							(Notes 2, 4)					T					
AISI 316 L ss gold plated							(Notes 2, 4)		NACE			N					
AISI 316 L ss with anti-stick coating							(Notes 2, 4)		NACE			K					
Hastelloy C276™ with anti-stick coating							(Notes 2, 4)		NACE			Y					
AISI 316 L ss with anti-corrosion and anti-stick coating							(Notes 2, 4)		NACE			W					
Diaflex (AISI with Anti Abrasion treatment)							(Note 2)		NACE			F					
Superduplex ss (UNS S32750 to ASTM SA479)							(Note 2)		NACE			E					
Capillary protection – 12 th character																	
AISI 316 L ss armour							(RECOMMENDED FOR HIGH TEMPERATURE)						A				
AISI 316 L ss armour with PVC protective cover													B				
Capillary length m (feet) – 13 th character																	
1 (3)														A			
1.5 (5)														B			
2 (7)														C			
2.5 (8)														D			
3 (10)														E			
3.5 (12)														F			
4 (13)														G			
4.5 (15)														H			
5 (17)														I			
5.5 (18)														J			
6 (20)														K			
6.5 (22)														L			
7 (23)														M			
7.5 (25)														N			
8 (27)														O			
9 (30)														P			
10 (33)														Q			
12 (40)														R			
14 (47)														S			
16 (53)														T			
Fill fluid – 14 th character																	
Silicone oil															S		
Inert fluid - Galden							(Notes 2, 5)								N		
Inert fluid - Halocarbon							(Notes 2, 5)								D		
Silicone oil for high temperature							(Note 2)								G		
Silicone polymer for low temperature							(Note 2)								C		
Mineral oil (FDA approved)							(Note 6)								W		
Vegetable oil (FDA approved)							(Note 6)								A		
Glycerin-water (FDA approved)							(Note 6)								B		
Certification – 15 th character																	
None																	1

2600T Pressure Transmitters

Model 268DD, 268HD, 268ND

SS/268XD_6

BASIC ORDERING INFORMATION S264W				X	X	X
Flushing ring: hole and thread – 16 th character						
None				N		
1 hole - 1/2in NPT				2		
2 holes - 1/2in NPT				3		
1 hole - 1/4in NPT				4		
2 holes - 1/4in NPT				5		
Flushing ring material – 17 th character						
None	(Note 7)					N
AISI 316 L ss	(Note 8)		NACE			A
Hastelloy C276	(Notes 4, 8)		NACE			H
Flushing ring: plug and gasket – 18 th character						
No plug - no gasket						N
No plug - garlock	(Note 8)					A
No plug - PTFE	(Note 8)					B
No plug - graphite	(Note 8)					C
AISI 316 L ss - no gasket	(Notes 8, 9)					D
AISI 316 L ss - garlock	(Notes 8, 9)					E
AISI 316 L ss - PTFE	(Notes 8, 9)					F
AISI 316 L ss - graphite	(Notes 8, 9)					G
Hastelloy C276 - no gasket	(Notes 8, 10)					H
Hastelloy C276 - garlock	(Notes 8, 10)					L
Hastelloy C276 - PTFE	(Notes 8, 10)					M
Hastelloy C276 - graphite	(Notes 8, 10)					P

- Note 1: Not available with EN size code D, E, F
- Note 2: Not available with food design size code 1, 2
- Note 3: Not available with ASME size code A, B, C
- Note 4: Not available with serrated seat finish code D, R, S
- Note 5: Suitable for oxygen service
- Note 6: Suitable for food application
- Note 7: Not available with flushing ring - hole and thread code 2, 3, 4, 5
- Note 8: Not available with flushing ring - hole and thread code N
- Note 9: Not available with flushing ring material code H
- Note 10: Not available with AISI 316L flushing ring material code A

Contact us

ABB Ltd.

Process Automation

Howard Road
St. Neots
Cambridgeshire PE19 8EU
UK
Tel: +44 (0)1480 475321
Fax: +44 (0)1480 217948

ABB Inc.

Process Automation

125 E. County Line Road
Warminster
PA 18974
USA
Tel: +1 215 674 6000
Fax: +1 215 674 7183

ABB Automation Products GmbH

Process Automation

Schillerstr. 72
32425 Minden
Germany
Tel: +49 551 905 534
Fax: +49 551 905 555

ABB S.p.A.

Process Automation

Via Statale 113
22016 Lenno (CO)
Italy
Tel: +39 0344 58111
Fax: +39 0344 56278

www.abb.com

Note

We reserve the right to make technical changes or modify the contents of this document without prior notice. With regard to purchase orders, the agreed particulars shall prevail. ABB does not accept any responsibility whatsoever for potential errors or possible lack of information in this document.

We reserve all rights in this document and in the subject matter and illustrations contained therein. Any reproduction, disclosure to third parties or utilization of its contents - in whole or in parts - is forbidden without prior written consent of ABB.

Copyright© 2010 ABB
All rights reserved

™ Hastelloy C276 is a Cabot Corporation trademark

™ Hastelloy C2000 is an Haynes International trademark

™ Monel is an International Nickel Co. trademark

™ Viton is a Dupont de Nemour trademark

™ DC200 and DC704 are Dow Corning Corporation trademarks

™ Galden is a Montefluos trademark

™ Halocarbon is a Halocarbon Products Co. trademark

™ Neobee M20 is a Stepan Company trademark

™ Marcol is a Esso Italiana trademark

™ Syltherm is a Dow Chemical Company trademark